



# User manual

## ISOCUBE

Isolating cabinet for Nanogun Airspray H<sub>2</sub>O

SAMES KREMLIN SAS - 13, Chemin de Malacher - 38240 MEYLAN - FRANCE  
Tel. 33 (0)4 76 41 60 60 - [www.sames-kremlin.com](http://www.sames-kremlin.com)

This document may not be disclosed or copied, in any form, and its content may not be used or disclosed, without the explicit written authorisation of SAMES KREMLIN.

The descriptions and characteristics contained in this document may be modified without prior notice.

© SAMES KREMLIN 2017



**WARNING :** SAMES KREMLIN SAS has been declared as a training centre with the Ministry of employment.

Our company organises training courses providing the indispensable know-how for the installation and maintenance of our equipment all year long.

A catalogue is available on request. Select the training programme, type of learning method and skills you need from our range, to meet your production targets.

These training courses can be organised on the premises of your company or at the training centre located at our head office in Meylan.

Training service:

Tel.: 33 (0)4 76 41 60 04

E-mail: formation-client@sames-kremlin.com

The symbol  means Warning important point.

SAMES KREMLIN SAS has drafted this operating manual in French and mandated English, German, Spanish, Italian and Portuguese translations.

The company declares reservations on all translations and refuses any liability with respect to these translated documents.

# ISOCUBE

## Isolating cabinet for Nanogun Airspray H<sub>2</sub>O

1. Health and safety guidelines	5
1.1. Marking	5
1.2. Simplified analysis of potential sources of electric shocks	5
1.3. Precautions during use	6
1.4. Warnings	6
1.5. Installation rules	7
1.6. Rules of use	7
1.7. Maintenance rules	8
2. Description	9
2.1. Overview front face	10
3. Characteristics	11
3.1. Characteristics of the compressed air	12
4. Use	13
4.1. Transport and Handling	13
4.2. Installation	14
4.3. Connection of the Nanogun Airspray H <sub>2</sub> O spray gun	15
4.4. Installation of the stirrer (option)	16
4.5. Start-up	17
4.5.1. Placement of the paint drum	17
4.5.2. Priming the pump	17
4.5.3. Ventilation	18
4.6. Settings and operating modes	19
4.7. Work on the inside of the isolating cabinet	20
4.8. Emergency stop	20
4.9. Complete shutdown of the installation	20
5. Cleaning	21
5.1. Ongoing maintenance	21
5.1.1. Nanogun Airspray H <sub>2</sub> O spray gun and hoses	21
5.1.2. Insulating cabinet	21
5.1.3. Electro-pneumatic headband	22
6. Maintenance	23
6.1. Maintenance table	23
6.2. Short circuiter 60kV	23
6.2.1. Preventive maintenance	23
6.2.3. Corrective maintenance	25
7. Common malfunctions and repairs	30
8. Spare parts	32
8.1. ISOCUBE Europe version	32
8.2. ISOCUBE US-CSA version	34
8.3. ISOCUBE cabinet equipped	36

8.3.1. Discharge resistor . . . . .	38
8.3.2. Short circuiter 60kV . . . . .	39
8.4. Pump unit . . . . .	40
8.5. Fitted stirrer (option) . . . . .	42

# 1. Health and safety guidelines

This document contains links to the following operation manuals:

- [see RT Nr 7117](#) For the Nanogun Airspray H2O spray gun
- [See user manual ref: 578 011 120](#) for the pump
- [See user manual ref: 573 025 111](#) for the product pressure regulator
- [See user manual ref: 578 001 130 1103](#) for the product filter
- [See user manual ref: 573 303 050](#) for the stirrer (option).

## 1.1. Marking

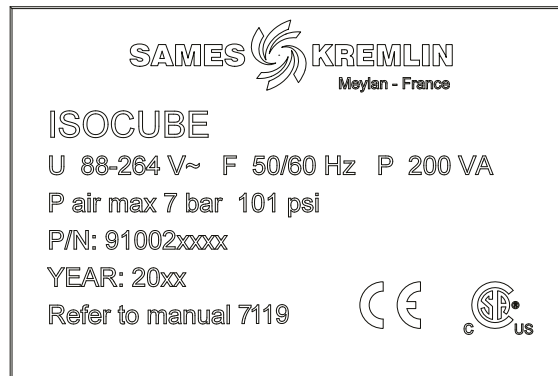

## 1.2. Simplified analysis of potential sources of electric shocks

With the use of non-flammable products (as defined in the draft standard pr EN 50059:2016 Annex C), the risk of ignition is by definition nil or low, but on the other hand, these products contain large quantities of water which quickly store quantities of energy sufficient to cause electric shocks that would exceed the limits as defined in the draft standard EN50059-2016 Annexes A and B.

That is why the ISOCUBE insulating cabinet is equipped with systems to prevent this type of risk.

Potential source of electric shock	Measures	Means applied
Voluntary or involuntary contact with the pump or the paint drum	Automatic earthing of all parts under HV if the door is opened	Time to implementation of security measures of less than 2 sec
Voluntary or involuntary contact with the spray gun injector	Limitation of the length of the product hose to 15 m max and the capacity of the product drum to maximum 30 l.	30 l max for all the containers which must be conductors and connected to the equipotential connection (supplied)
	Resistance against permanent discharge	
	Prohibition of spraying of products with a resistivity below 1000 $\Omega$ .cm.	
Incorrect earthing	The equipment must be earthed by means of at least 2 points: its electrical supply and a dedicated wire (supplied)	The operator must periodically check the quality of the earthing outlets

### 1.3. Precautions during use

All operators must familiarise themselves with and understand the information in this document before using the **ISOCUBE** equipment. This information points out situations that can cause serious damage and indicates the precautions to be taken to avoid them.



**WARNING :** Before using the **ISOCUBE** equipment, be sure that all operators:

- have received preliminary training from **SAMES KREMLIN**, or from the distributors it has certified for this purpose.
- have read and understood the user's manual as well as all installation and use rules listed below.

It is incumbent upon the **Operators' Workshop Manager** to ensure and verify that all operators have read and understood the user's manuals relative to peripheral electrical devices present within the spraying perimeter.

### 1.4. Warnings



**WARNING :** This equipment may be hazardous if it is not used, disassembled and reassembled in accordance with the rules indicated in this manual and in any applicable European Standard or national safety regulations.



**WARNING :** The good working order of this equipment is only under warranty provided that original spare parts distributed by **SAMES KREMLIN** are used. Only components and accessories distributed by **SAMES KREMLIN** contained in this user manual may be used.



**WARNING :** This equipment is intended to spray non flammable liquids.

### 1.5. Installation rules

- The **ISOCUBE isolating cabinet** has been designed to operate within a 2nd-degree pollution environment, as defined according to the Standards IEC 60664-1 and IEC 61010-1:2010.  
**2nd-degree pollution:** Under normal use conditions, only non-conductive type pollution arises. On a temporary basis, conduction caused by condensation may arise.
- The **ISOCUBE isolating cabinet** must be installed indoors, outside installation is strictly prohibited.
- The hand-held electrostatic projection equipment can only be used in designated projection spots in accordance with Standard EN 12215 or under equivalent ventilation conditions.
- This equipment must not be used in a cab or an application room for solvent-based paints, flammable liquids or ones which form explosive atmospheres.
- The use of this equipment in a work area for the application of electrostatic flammable products or ones which form explosive atmospheres is dangerous.
- The ISOCUBE consists of the projection spray gun, the control module, the hose, the pump and the product tank, which must be considered as a whole. Any technical change can increase the stored electric energy in the whole set to a dangerous degree. It is strictly forbidden to modify the equipment.
- Install the isolating cabinet **away from any explosive zone**.
- Servo-control the isolating cabinet to the "on" position of the booth's suction fan.
- Correctly connect the control module to the installation's ground terminal.
- Connect the pump and the product tank by means of an equipotential connection that is provided.
- The container of the spray product must be electrically conductive (metal).
- Connect all metal parts of the installation (paint pumps, containers, stools, spin coaters, etc., which positioned within three meters of the spray gun to the ground.
- Keep the spray zone clean and free of all unnecessary components.
- The floor where the operator works must be antistatic (either unclad concrete flooring or a metal grating). Never cover the floor with an insulating covering. In potentially explosive locations, the floor assemblies must be antistatic, in accordance with Standard EN 61340-4-1.
- The use inside the booth of an uncovered flame, any incandescent object, a device or object capable of generating sparks other than the spray gun is strictly prohibited.  
It is also prohibited to store in the vicinity of the booth or in front of the doors flammable products or containers in which such products had been stored.
- The jars and cans containing paint or solvent must be systematically closed after use.
- The paint feed pump used must be rated with a maximum 1.8:1 ratio, and the pump's air supply must be equipped with a safety relief valve (supplied) to limit pressure to a maximum value of 6.5 bar.
- **Inside an explosive zone**, it is prohibited to use electrical or non-electrical equipment that has not been certified, like electrical extension cables, surge protector power bars, switches, etc.

### 1.6. Rules of use

- Verify the extraction ventilation system efficiency on a daily basis.
- Once a week, verify the adequate operations of the ventilation system servo controls.
- Correctly ground all metal parts of the booth, along with the parts to be painted. The resistance relative to the ground must be less than or equal to  $1M\Omega$  (for a 500-V voltage measurement). This resistance must be regularly checked and, in any case, at least once a week.
- The operator must wear antistatic shoes in accordance with Standard EN 61340-4-3 and moreover hold the **Nanogun Airspray H2O** spray gun either with a bare hand or with antistatic gloves or gloves modified so as to establish a direct contact between the butt and his/her hand. The shoes intended to be worn by the operator must be compliant with

- Standard ISO 20344. The measured insulation resistance must not exceed 100MΩ
- The protective clothing intended to be worn, including gloves, must be compliant with Standard EN 1149-5. The measured insulation resistance must not exceed 100MΩ
  - The operator must also wear ear defenders when using the spray guns **Nanogun Airspray H<sub>2</sub>O**.
  - Ensure that anyone entering the spray zone is wearing the antistatic shoes or has been grounded by any other means.
  - The device can only be operated if it is in perfect condition. Any damaged equipment must be immediately removed from active service and repaired. Worn parts must be immediately replaced.
  - Only use paints whose flash point is at least 15°C higher than room temperature.
  - Closely follow use guidelines for the paints and solvents being applied (e.g. wear a mask).
  - Close and purge both the air and paint inlet prior to any extended equipment downtime.
  - Before any cleaning or maintenance operation, discharge the equipment to earth (the discharge is done automatically if the door is open).
  - Verify the good working order of the paint hose prior to any equipment start-up.

### 1.7. Maintenance rules

- Regularly maintain and repair the electrostatic projection equipment according to the instructions contained in this user's manual.
- Only use metal containers to hold the cleaning liquids and connect to ground according to a safe procedure.
- Before any maintenance procedure:
  - 1 Turn off the control module.
  - 2 Dump the paint circuit.
  - 3 **Verify that the air and paint circuits are no longer pressurised.**
  - 4 All energy sources must be locked out.
- Clean the equipment either in their dedicated spots with mechanical ventilation or by using cleaning liquids with a flash point at least 15°C higher than ambient temperature.
- Use non-flammable cleaning products.



**WARNING :** It is strictly prohibited to use solvents derived from halogenated hydrocarbons as well as products containing these solvents in the presence of aluminium or zinc. Failure to comply with these guidelines exposes the user to the risks of explosion.



## 2. Description

This equipment is designed for the application of water-based or water-thinnable hydrosoluble paint or varnish. The liquids sprayed must be non-flammable and highly conductive to electricity.

To apply paints of this type electrostatically, the most simple and most effective way is to place the liquid under high voltage, and electrically isolate the paint supply system.

The ISOCUBE isolating cabinet consists of:

- a **Nanogun Airspray H2O** spray gun (Item 1) ([see RT Nr 7117](#)),
- an electropneumatic box (Item 2) including the **GNM 6080** control module (Item 3),
- A pneumatic piston pump (Item 4) supplying the spray gun,
- A 60kV short circuiter located on the top of the cabinet,
- a stirrer (Item 5) as an optional extra.

The ISOCUBE cabinet is equipped with safety systems that protect the operator against electrical shocks, by blocking access to the parts under high voltage.



## 2.1. Overview front face

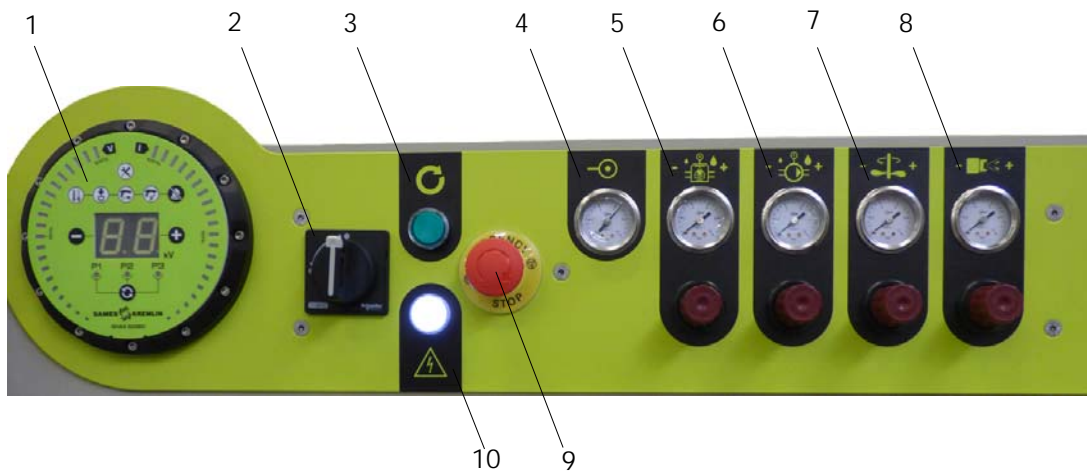

Item	Description
1	GNM 6080 control module ( <a href="#">see RT Nr 7117</a> )
2	Main switch (lockable)
3	On / off button (green)
4	Air supply pressure
5	Pressure flow regulator
6	Pressure pump power supply
7	Stirring supply pressure
8	Spraying air supply pressure (spray gun)
9	Emergency stop
10	Voltage presence white LED indicator

### 3. Characteristics

Footprint (W x H x P)	1100 x 1640 x 650	
Mass	167 Kg	
Maximum operating altitude	2,000 m	
Min/max ambient temperature	5°C - 40°C	
<b>Maximum relative humidity</b> of 80% for temperatures of up to 31°C, then linear decrease until 50% relative humidity at 40°C	Maximum of 80% without condensation	
Operating voltage	60 kV maximum [+0 kV; -1.5 kV] (adjustable on GNM 6080)	
Maximum current	80 µA max.	
Electrical power supply:	<b>Europe version</b>	<b>CSA Version</b>
- Voltage	220 V ± 10%	110V ± 10%
- Frequency	50 -60 Hz	50 -60 Hz
- Consumption	200 VA	200 VA
Overvoltage	Overvoltage category II according to Standard IEC 61010-1:2010	
Maximum compressed air pressure	7 bar (101 psi) (exhaust valve calibrated at 6,5/7 bar)	
Max. air flow	Approximately 40 Nm <sup>3</sup> /h.	
Product viscosity	Between 20 mPas/s and 140 mPas/s approximately	
Max. product flow	According to the viscosity and the thixotropy of the product (*): - Approx. 700 cc/min. for a liquid at 30 s by weight AFNOR no. 4: - Approx. 250 cc/min. for a liquid at 50 s by weight AFNOR no. 4:	
Products	Non flammable paints with a minimum resistivity that must be between 1KΩ.cm and maximum 250 kΩ.cm. (**).  <b>WARNING : Not appropriate and also dangerous for the solvent-based paints, resistive liquids and flammable liquids that form explosive atmospheres.</b>	
Filtration of the coating product	Provided by a filter-strainer (200 µm) which is easily dismantled and cleaned.	

(\*) - The measurement of the viscosity of a water-soluble paint using a consistometric cup leads to very significant errors. In effect, these paints are thixotropic: their viscosity decreases with the intensity of agitation and with the time for which they are stirred. At rest, these paints are highly viscous substances; in contrast, in movement, they become not very viscous substances. The viscosities shown are indicative for paint stirred just before being measured with a cup.

(\*\*) - Any other use is prohibited

### 3.1. Characteristics of the compressed air

Required characteristics of the compressed air supply according to Standard NF ISO 8573-1

Characteristics	Value
Maximum dew point at 6 bar (87 psi)	Category 4, i.e. +3°C (37° F)
Maximum particle size distribution of the solid pollutants	Category 3 i.e. 5 µm
Maximum oil concentration	Category 1, i.e. 0.01mg / m <sub>0</sub> <sup>3</sup> *
Maximum concentration of solid pollutants	5 mg / m <sub>0</sub> <sup>3</sup> *

(\*): The values are given for a temperature of 20°C (68°F) at atmospheric pressure.

## 4. Use

### 4.1. Transport and Handling

The ISOCUBE insulating cabinet is delivered in a box that can be handled with a forklift or pallet truck.

The cabinet out of its packaging is handled by means of the forklift or pallet truck, but also by means of straps through the four holes on the sides of the cabinet.



#### 4.2. Installation

- The ISOCUBE isolating cabinet must be installed and used outside of any explosive area.
- The main switch must be free of access in order to facilitate any operation.
- Ensure the correct earth connection of the parts to be painted (open electrical connection of the electrical earthfeeder, cleanliness of the metal suspension hooks).
- Be sure to maintain this good connection the whole time. Ensure that the suspension hooks are frequently stripped.
- Connect the **Nanogun Airspray H<sub>2</sub>O**.
  
- The elements of the ISOCUBE (electro-pneumatic box, pump, pressure regulation, security systems) are delivered connected.
- Connections of the cabinet:
  - Connect the earth of the cabinet using the earth wire fitted with a terminal.
  - Connect the compressed air inlet hose (customer supplied) (3/8" BSP female, Ø 8 interior, length 10 m maximum) to the supply valve.
  - Connect the AC power cord to the electrically adapted network (the supply voltage is indicated on the nameplate located on the cabinet).

**Nota:** The symbol  means "**Caution: Electrical shock hazard**".

### 4.3. Connection of the Nanogun Airspray H2O spray gun

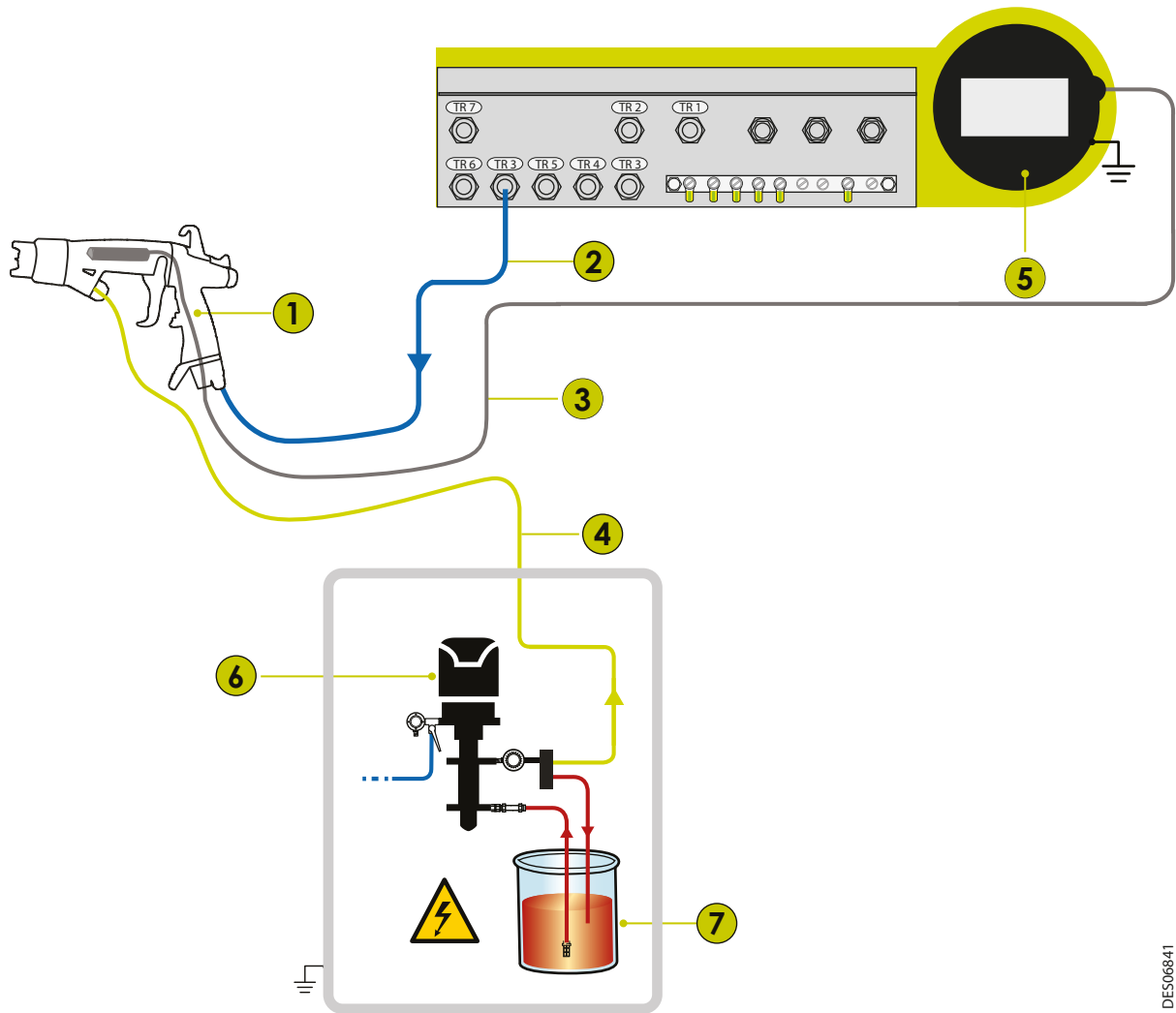

DES06841

Item	Description
1	Nanogun Airspray H2O spray gun
2	Spray air(quick coupler to connect on TR 3)
3	Low-voltage cable (screw-on connector on the female connector of the GNM 6080)
4	Product hose passing through the cable gland, to connect to the pump (Ref.: 910020516-075), maximum length: 15 m
5	GNM 6080
6	Pump (maximum product pressure 10 bar - 145 psi)
7	Paint drum (max. capacity. 30L - 7.92 US gal)

#### 4.4. Installation of the stirrer (option)

- **Step 1:** Attach the stirrer to the edge of the product drum or on the edge of the retention tray.



- **Step 2:** Connect the black wire for equipotential bonding to the connection point of all the equipotential connections on the pump.



- **Step 3:** Connect the compressed air hose to the quick coupler on the top left of the cabinet.

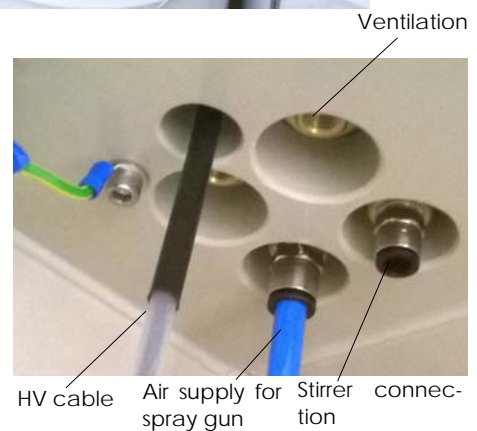



## 4.5. Start-up



**WARNING :** The complete start-up is done by "double clicking" the green button.



**The first press** triggers the compressed air supply for the pump, the regulator (if present) and the ventilation of the cabinet.

This makes it possible fill, flush and/or dump the product circuit quickly, and this action is functional even if the door is open or unlocked.

**The second press** triggers the power supply to the GNM 6080, the compressed air required for the spray gun, for the stirrer if it is present, for the short circuiter and its ventilation, and the ISO-CUBE is then ready to operate. **If the door is left open or not locked, this second press has no effect.**

### 4.5.1. Placement of the paint drum

- Place the paint drum on the receptacle in the isolating cabinet, covered in its cover. It is important to put the cover on to avoid the hose coming out under the effect of the pressure of the product.
- Make sure that there is no product dripping onto the receptacle for the drum.

### 4.5.2. Priming the pump



**WARNING :** To start the pump, you must:

- Open the door in order to allow the equipment to discharge to the earth.
- Pour the vaseline oil into the cup (= cylindrical part in which the piston rod is located).
- If there are priming difficulties (pasty coating product), start the priming with water to fill the hoses, then replace the water with the coating product.
- It is important, for the life of the pump, not to allow it to run unprimed (operating at more than 30 cycles/min).

#### 4.5.3. Ventilation

##### Check internal ventilation:

- Switch on the ISOCUBE cabinet. Press the green button once. Open the door.
- Place a finger on the ventilation outlet at the top left of the cabinet. A light blast of air must be perceived (pressure 0.1 bar +0.1 -0).

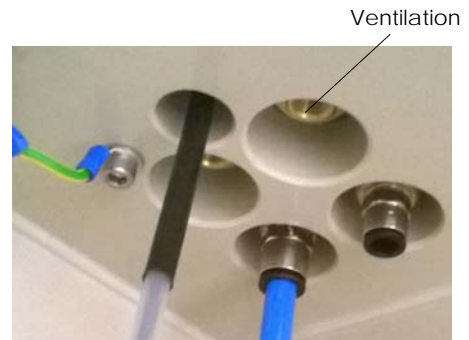

Booth ventilation: [see § 1.5 page 7](#) alinéa 3.

#### 4.6. Settings and operating modes



- **Compressed air pressure** (Item 1):  
The equipment has an air exhaust valve which dumps the air from the network if the pressure is greater than 6.5/7 bar.  
In this case, you will hear the noise of air dump: lower the air pressure in the network.
- **Product pressure regulator** (Item 2):  
Depending on the viscosity of the product, the flow and the injector used, adjust the pressure to between 0.3 and 5 bar. The maximum product flow is reached at approximately 6.5 bar but a higher fog is created.  
The higher the pressure, the higher the flow sprayed.
- **Pressure pump power supply**(Item 3):  
The supply pressure of the pump must be adjusted in the following manner  
Air pressure on the pump = (air pressure on the regulator + 1) / 1.8 pressure in **bar**.  
or  
Air pressure on the pump =(air pressure on the regulator +14.5)/1.8 pressure in **PSI**.  
  
A too high difference in air pressure between the pump and the regulator causes a significant fatigue, and premature wear of the membrane of the regulator and the seals of the piston of the pump.
- **Air pressure on the stirrer** (Item 4) (**option**) :  
Between 2 and 4 bar depending on the viscosity of the product, and the rotation speed of the propeller must be adjusted using the needle valve on the engine.
- **Spraying air supply pressure**(Item 5):  
From 1.4 to 6 bar depending on the product's viscosity and flow ([see RT Nr 7117](#)).  
Beyond 4 bar, the de-solvation of the product and the production of mists can increase significantly.



**WARNING** : Do not modify the pressure setting of the valve, as the proper functioning of the pump depends on it. It is very important to use de-oiled and drained compressed air to ensure the proper functioning of the equipment.

#### **4.7. Work on the inside of the isolating cabinet**

You only have to unlock and open the door, and all energies are cut with the exception of the compressed air which supplies power to the pump, the regulator and the cabinet ventilation. All the parts placed under high voltage are earthed in approximately 0.8 sec, and the complete discharge takes place after approximately 2 sec with a good quality earthing connection.

The product circuit (pump and regulator) remains under pressure and powered, which allows you to perform the dump and rinsing operations.

To restart, lock the door and then press (single-click) on the green button.

#### **4.8. Emergency stop**

The emergency stop switches off all the energies. However, a residual pressure is still present in the product circuit (between the output of the pump and the spray gun) as long as the operator does not actuate the trigger of the spray gun. After disarmament of the emergency stop, a double-click must be done on the green button to restart.

#### **4.9. Complete shutdown of the installation**

Turn the knob of the disconnecter 90° anti-clockwise. Close the air supply valve.

## 5. Cleaning

Before any operation on the insulating cabinet, refer to the Health and Safety instructions ([see § 1.4 page 6](#)), for the spray gun [see RT Nr 7117](#).



### WARNING :

- The operations on the components of the paint circuit must not be done until the pump and the spray gun have been rinsed with water or a nonflammable product that is appropriate for the sprayed product.
- Before any maintenance operation, discharge the equipment to the earth (by opening the door of the ISOCUBE), disconnect the AC power cord, dump the product from the hoses (by pressing on the trigger of the spray gun, cut off the air supply and dump the air.

### 5.1. Ongoing maintenance

- It is very important to maintain the ISOCUBE in a perfect state of cleanliness (without dripping product).
- Operate in a well ventilated and explosive-proof area, with the control module out of service. Dry the cleaned areas well before restarting.
- Periodically refill the pure Vaseline oil in the cup of the pump. It is normal for this oil to stain.
- Check that the cup remains clean and clean it regularly, as well as the drips, with a non-greasy solvent after draining the oil, (do not use butyl-glycol).
- Flush pump as often as necessary, in particular when using loaded product with a tendency to depositing.
- Regularly replace the seal kit and the cartridge of the pump. This preventative maintenance depends on the settings for the use of the pump, **(e.g.: beat frequency of 15 cycles per minute, "air pump" pressure of 3 to 4 bar, standard product (not very loaded): Replace the seal kit and cartridge every 6 months)**. Refer to the package leaflet of the pump for more details.
- The interior of the cabinet is designed to remain dry and clean. If a fluid leak occurs, clean it up. Search for the causes of the leak and repair them.
- From time to time, disassemble the filter-strainer (removable in two parts) of the pump suction hose plunger and clean it.
- Be sure to re-assemble it on the suction hose plunger.
- Regularly check the continuity of the earthing of the equipment, with the aid of a megohm meter with a test voltage of 500 V. Place the tip of a contact on the handle of the spray gun, and the other tip on the earth terminal of the ISOCUBE. The value read should be: 1 M $\Omega$ .
- Operate with a multimeter in the ohmmeter position between the earth terminal of the ISOCUBE and the earth terminal of the electrical socket on the power cord. The value must not exceed 2  $\Omega$ .

5.1.1. **Nanogun Airspray H<sub>2</sub>O spray gun** and hoses  
[see RT Nr 7117](#)

5.1.2. Insulating cabinet

The use of a low or high pressure water jet is strictly prohibited (except for the retention tank [see § 5.1.2.3 page 22](#)).

Clean with water or with a non-aggressive, non-greasy, non-flammable solvent. Do not use butyl-glycol.

#### 5.1.2.1. Outer part except electro-pneumatic headband

- Clean with a rag soaked in water or solvent that is not aggressive, greasy or flammable, do not use butyl glycol.
- Dry by wiping off non-accessible parts (e. g. door hinges) with a dry rag and/or under moderate pressure (maximum 2 bar - 30psi) with compressed air.

#### 5.1.2.2. Inner part

- Clean with a rag soaked in water or solvent that is not aggressive, greasy or flammable, do not use butyl glycol.
- Dry very carefully with compressed air, especially in places that are not easily accessible with a rag, finish drying large surfaces with a perfectly dry rag.
- Pay special attention to drying the following points:
  - the inner surface and the door frame, including the metal frame.
  - at the bottom of the cabinet and at a height of at least 300 mm to 400 mm.
  - to the retention container.
  - to the discharge resistance.

#### 5.1.2.3. Retention container

- The retention tank can be cleaned when it is outside the cabinet by means of a water jet under pressure (max. 130 bar, temperature 40°C) .  
When using a rotating nozzle, make sure that the surface condition of the material is not degraded, making it increasingly difficult to clean over time.
- Dry very carefully with compressed air on all surfaces and especially in the inside edges and corners.

#### 5.1.3. Electro-pneumatic headband

- Clean the front face of the GNM 6080 control module with a cloth soaked in water and in the case of extreme dirt, clean the windows of the air pressure gauges with a cloth soaked in a non aggressive, non-oily, nonflammable solvent, do not use butyl glycol.  
In this case make sure that solvent does not come into contact with the electrical buttons and indicators, and the front plate.
- Dry by wiping with a dry rag, the use of compressed air without being prohibited should only be done at moderate pressure (maximum 2 bar - 30psi) on this part of the cabinet.

## 6. Maintenance

### 6.1. Maintenance table

Detail	Preven- tive measure	Correc- tion	Dura- tion	Frequency
<b>Short circuiter</b>				
Visual inspection of the earth straps	X		5 mn	1x per month
Check of the cylinder closure	X		5 mn	1x per week
Check of the air exchange	X		5 mn	1x per week
Check of spheres	X		30 mn	1x per year
<b>Replacing spheres</b>				
Replacing spheres		X	1 H	-
<b>Replacing high voltage cable</b>				
Replacing high voltage cable		X	30 mn	> 10000 H
<b>Replacing the fuse locating in the electro-pneumatic box*</b>				
Replacing the fuse locating in the electro-pneumatic box*		X	5 mn	-
<b>Nanogun Airspray H<sub>2</sub>O spray gun</b>				
<a href="#">see RT Nr 7117</a>				
<b>Low pressure pump unit</b>				
Pump: <a href="#">see user manual ref: 578,011,120</a>				
Product pessage regulator: <a href="#">See user manual ref: 573,025,111</a>				
Product filter: <a href="#">See user manual ref: 578,001,130 1103</a>				
<b>Stirrer (option)</b>				
<a href="#">See user manual ref: 573,303,050</a>				

\* Characteristics of the fuse: 10\*38 500V 4A class gG.

### 6.2. Short circuiter 60kV

#### 6.2.1. Preventive maintenance

##### 6.2.1.1. Closure of the cylinder

- Switch off the power to the cabinet. Open the upper hood
- Using a multimeter, measure the resistance between a point connected to the potential of the earth socket on the short circuiter and any point connected to the high voltage on the installation (for example a metal part of the pump or the alligator clip of the equipo-  
tential connection). The value read should be less than 1 Ω.

### 6.2.1.2. Air change

- Remove the exhaust silencer.
- Place a finger in front of the port:
  - If the air passes: the air exchange is correct.

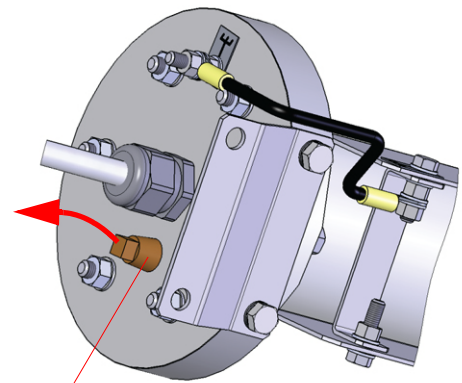

Exhaust silencer

- If the air does not pass: Close the flow rate adjuster located at the rear of the box and then open it 1.5 turns to 2 turns to obtain a slight puff on the muffler. Tighten the counter nut.
- Refit the exhaust silencer.



Flow rate adjuster



### 6.2.2. Check of spheres

- **Check the contact of the two spheres:** Place a multimeter between the high voltage wells and the earth of the short-circuiter.
- **Visual check:** Remove the cover of the short circuiter, and remove the flange on the high voltage wells. Check the condition of the two spheres, remove any trace of oxidation using grade 2000 sandpaper and blow it out with compressed air.  
In the event of traces of major fusion (fusion craters: Dia. > 3 mm), replace them.



**WARNING :** It is important to eliminate all residues, as the inside of the short circuiter must be free of impurities and moisture. The cleaning must be done with a dry cloth, and the use of a solvent or a detergent is strictly prohibited.

### 6.2.3. Corrective maintenance.

#### 6.2.3.1. Replacing spheres

- Remove the cover and then the flanges at each end of the polypropylene tube.
- **On the cylinder:** Keep the cylinder rod retracted beforehand using a flat key, loosen the counter nut that locks the sphere and unscrew the sphere. Do not change the winding of the earthing wire.
- **On the high voltage wells:** Remove the dielectric grease of the high voltage wells, clean it (an acetone type solvent can be used). Insert a long flat blade screwdriver (width 8 or 10 mm) into the high voltage wells to maintain the high-voltage contact (screw) and unscrew the second sphere.

#### Installing the spheres

Proceed in the reverse direction.

- Insert the two spheres and the counter nut, previously coated with a normal threadlock (Ref.: H2CPAL046).



**WARNING :** It is imperative to comply with the dimension in the position of the removed cylinder ball of  $143.5 \pm 1$  mm between the face of the ball and the cylinder support baseframe.

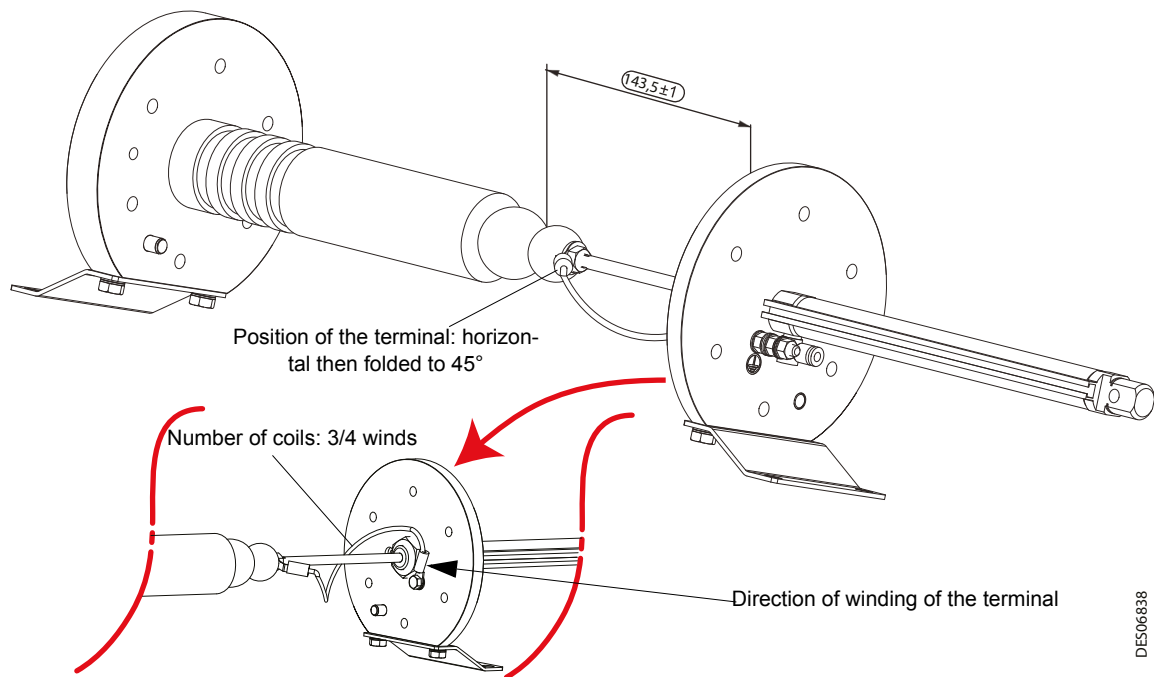

**WARNING : On reassembly: Remove the leftover grease on the cable.**

- Fill the high-voltage wells with dielectric grease (Ref.: H1GSYN037) taking care not to introduce dust or impurities. After the introduction of the cable, there must not be any air bubbles in the high voltage wells.



**WARNING : After refitting the cover, check the tightness of the earth terminals and check the electrical continuity between the two flanges of the short circuiter.**

### 6.2.3.2. Replacing the high voltage cable

- Loosen the nut of the cable gland (Ref.1) to release the cable while holding the body of the cable gland (Ref.2).

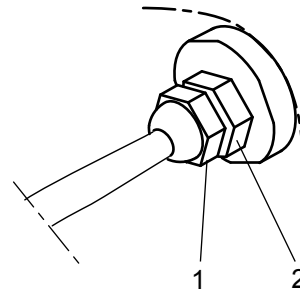

DES03407

- Remove the cable.
- Change the cable. For the preparation of the high voltage cable ([see § 6.2.3.3 page 28](#)).
- For the reassembly step, proceed in the reverse order.
- Fill the high-voltage wells with dielectric grease (Ref.: H1GSYN037) taking care not to introduce dust or impurities. After the introduction of the cable, there must not be any air bubbles in the high voltage wells.

### 6.2.3.3. Preparing the high voltage cable

#### Tooling required:

- Tube cutter (Ref.: W3SCTU002).
- Low grain Emery cloth (so as not to scratch the insulation cable)
- Pair of scissors.
- Cable stripper (grain of rice)
- Restrictor tool (Ref.: 1408598).
- Knife with automatic retractable blade.
- Pipe wrench (6)
- Cut-resistant gloves.

#### • Step 1:

Strip 275 mm of the purple outer sheath with a cable-stripper (grain of rice). It is imperative not to use a sharp "cutter"-type tool.



#### • Step 2:

Cut away the residue with the aid of cutting pliers or a pair of scissors.



#### • Step 3:

Remove 255 mm of black sheath (keep 20 mm) by peeling it manually in a spiral (start with the pliers if necessary). Cut away the residue with the aid of cutting pliers or a pair of scissors.



**WARNING :** Do not use any cutting tool, as the slightest scratch or start of a nick on the surface of the insulation inside would make the cable unusable.

- **Step 4:**

Hold the cable with the sandpaper and make a front hole in the central part of the cable with the tool (Ref.: 1408598).



Connect the end piece by screwing it into the front hole while holding the cable with the sandpaper.

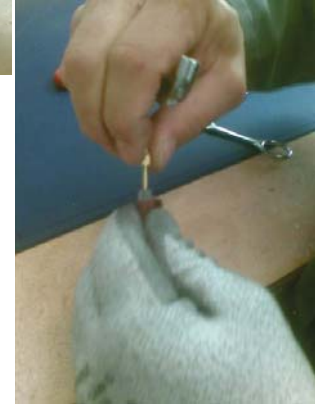

Using a pipe wrench 6, screw the end onto the cable until it stops.



## 7. Common malfunctions and repairs

Symptoms	Possible causes	Troubleshooting
No air when pressing on the trigger of the pistol.	Door open	Close the door, press the green button
	Bad adjustment of the "spray air" pressure.	Adjust the pressure of the feed with the dedicated pressure regulator
The spray product does not come out, or does it in jerks.	More the product in the tank.	Fill it.
	Bad adjustment of the "pump air" pressure of the regulator.	Adjust the pressure of the feed with the dedicated pressure regulator.
	Injector of the spray gun dirty.	Clean it.
	Paint strainer-filter dirty.	Clean it.
	The pressure regulator is dirty.	Clean it.
	Obstructed paint hose	Rinse the equipment.
	Deactivated pump.	Prime it
	Incorrect adjustment of the spray gun needle valve.	Please refer to the operation manual.
Viscosity of the coating product too high.	Dilute it.	
The pump will not start	Lack of air supply	Check the air supply to the pump
Problem priming: - Air always comes out of the spray gun  - Nothing comes out of the spray gun	Check the pump (see pump ratio)	Ensure that the spray gun is open and that the air is being well flushed out of it Air intake to the fitting or to the suction tube.
Closed spray gun, but the pump continues to beat: - In the 2 directions  - It stops only while descending.  - It stops only while going up.		Check the seal of the valve, the cartridge and the pump valves. Check the discharge valve or the seal on the valve.  Check the suction valve and the upper cartridge.
The pump is blocked with air leaking to the engine		Check the engine valve located under the bell.
The control module does not deliver high-voltage.	Door open	Close the door, press the green button

Symptoms	Possible causes	Troubleshooting
A lot of current will flow through the control module, or it disconnects.	Leakage or soiling in the compartment of the tank and the pump.	Remove the causes of the leak, clean and dry the dirty parts.
	Internal paint leak in the spray gun.	<a href="#">see RT Nr 7117</a>
	Short circuiter defective.	Check its operation, then repair and replace it if necessary.
	Painting hose of the spray gun electrically penetrated.	Replace it, <a href="#">see RT Nr 7117</a>
Paint in the air hose for controlling the regulator.	Regulator membrane defective.	Replace it. Replace the air hoses and the pressure regulator if necessary.
Incorrect operation of the stirring/supply system for the spray gun. (optional)	Pneumatic motor is defective	Repair or replace if necessary
	Pressure regulator at zero or defective	Increase the pressure Replace if defective.
Noise from jerky air dump when the equipment is pressurised.	Air pressure of network too high.	Adjust it to 6.5 bar maximum.
The operator has felt electrical discharges when painting.	He uses insulating gloves.	Remove the gloves or cut them so that the palm of the hand is in contact with the butt of the spray gun.
	The barrel of the spray gun is dirty.	Clean it.
	Poor earth continuity of the spray gun.	Check the earth continuity of the air hoser of the spray gun and the cable.
The operator feels electric shocks when he removes the tank from the ISOCUBE cabinet.	Sensor for closure of the door defective.	Check the action of the sensor on the short circuiter. Replace it if necessary.
	Short circuiter defective.	Check its operation; repair or replace it if necessary.

## 8. Spare parts

### 8.1. ISOCUBE Europe version



Item	Part Number	Description	Quantity	Sales unit	Spare parts level (*)
	910023635	ISOCUBE with Nanogun Airspray H2O round spray Ø 6 - 7.5 m	1	1	-
	910026034	ISOCUBE with Nanogun Airspray H2O round spray Ø 6 - 15 m	1	1	-
1	-	ISOCUBE cabinet equipped (see § 8.3 page 38)	1	-	-
2	-	Electro-pneumatic box	1	-	-
3	149220760	Stirrer (see § 8.5 page 44)	Option	1	2
4	-	Pump unit (see § 8.4 page 42)	1	-	-
5	910023072-075	Nanogun Airspray H2O round spray Ø6 -7.5 m (see RT Nr 7117)	1	1	3
	910023072-150	Nanogun Airspray H2O round spray Ø6 - 15 m (see RT Nr 7117)	1	1	3



Item	Part Number	Description	Quantity	Sales unit	Spare parts level (*)
	910023634	ISOCUBE with Nanogun Airspray H <sub>2</sub> O round spray Ø 8 - 7.5 m	1	1	-
	910026033	ISOCUBE with Nanogun Airspray H <sub>2</sub> O round spray Ø 8 - 15 m	1	1	-
1	-	ISOCUBE cabinet equipped ( <a href="#">see § 8.3 page 38</a> )	1	-	-
2	-	Electro-pneumatic box	1	-	-
3	149220760	Stirrer ( <a href="#">see § 8.5 page 44</a> )	Option	1	2
4	-	Pump unit ( <a href="#">see § 8.4 page 42</a> )	1	-	-
5	910023071-075	Nanogun Airspray H <sub>2</sub> O round spray Ø8 - 7.5 m ( <a href="#">see RT Nr 7117</a> )	1	1	3
	910023071-150	Nanogun Airspray H <sub>2</sub> O round spray Ø8 - 15 m ( <a href="#">see RT Nr 7117</a> )	1	1	3

Item	Part Number	Description	Quantity	Sales unit	Spare parts level (*)
	910023633	ISOCUBE with Nanogun Airspray H <sub>2</sub> O round spray Ø 12 - 7.5 m	1	1	-
	910026032	ISOCUBE with Nanogun Airspray H <sub>2</sub> O round spray Ø 12 - 15 m	1	1	-
1	-	ISOCUBE cabinet equipped ( <a href="#">see § 8.3 page 38</a> )	1	-	-
2	-	Electro-pneumatic box	1	-	-
3	149220760	Stirrer ( <a href="#">see § 8.5 page 44</a> )	Option	1	2
4	-	Pump unit ( <a href="#">see § 8.4 page 42</a> )	1	-	-
5	910023070-075	Nanogun Airspray H <sub>2</sub> O LR round spray Ø12 - 7.5 m ( <a href="#">see RT Nr 7117</a> )	1	1	3
	910023070-150	Nanogun Airspray H <sub>2</sub> O LR round spray Ø12 -15 m ( <a href="#">see RT Nr 7117</a> )	1	1	3

Item	Part Number	Description	Quantity	Sales unit	Spare parts level (*)
	910023636	ISOCUBE with Nanogun Airspray H2O flat spray - 7.5 m	1	1	-
	910026035	ISOCUBE with Nanogun Airspray H2O flat spray - 15 m	1	1	-
1	-	ISOCUBE cabinet equipped ( <a href="#">see § 8.3 page 38</a> )	1	-	-
2	-	Electro-pneumatic box	1	-	-
3	149220760	Stirrer ( <a href="#">see § 8.5 page 44</a> )	Option	1	2
4	-	Pump unit ( <a href="#">see § 8.4 page 42</a> )	1	-	-
5	910023073-075	Nanogun Airspray H2O flat spray - 7.5 m ( <a href="#">see RT Nr 7117</a> )	1	1	3
	910023073-150	Nanogun Airspray H2O flat spray - 15 m ( <a href="#">see RT Nr 7117</a> )	1	1	3

(\*)

Level 1: Standard preventive maintenance.

Level 2: Corrective maintenance.

Level 3: Exceptional maintenance.

## 8.2. ISOCUBE US-CSA version



Item	Part Number	Description	Quantity	Sales unit	Spare parts level (*)
	910023781	ISOCUBE with Nanogun Airspray H2O round spray Ø 6 - 7.5 m	1	1	-
	910026042	ISOCUBE with Nanogun Airspray H2O round spray Ø 6 - 15 m	1	1	-
1	-	ISOCUBE cabinet equipped ( <a href="#">see § 8.3 page 38</a> )	1	-	-
2	-	Electro-pneumatic box	1	-	-
3	149220760	Stirrer ( <a href="#">see § 8.5 page 44</a> )	Option	1	2
4	-	Pump unit ( <a href="#">see § 8.4 page 42</a> )	1	-	-
5	910023072-075	Nanogun Airspray H2O LR round spray Ø6 7.5 m ( <a href="#">see RT Nr 7117</a> )	1	1	3
	910023072-150	Nanogun Airspray H2O LR round spray Ø6 15 m ( <a href="#">see RT Nr 7117</a> )	1	1	3

Item	Part Number	Description	Quantity	Sales unit	Spare parts level (*)
	910023782	ISOCUBE with Nanogun Airspray H <sub>2</sub> O round spray Ø 8 - 7.5 m	1	1	-
	910026043	ISOCUBE with Nanogun Airspray H <sub>2</sub> O round spray Ø 8 - 15 m	1	1	-
1	-	ISOCUBE cabinet equipped ( <a href="#">see § 8.3 page 38</a> )	1	-	-
2	-	Electro-pneumatic box	1	-	-
3	149220760	Stirrer ( <a href="#">see § 8.5 page 44</a> )	Option	1	2
4	-	Pump unit ( <a href="#">see § 8.4 page 42</a> )	1	-	-
5	910023071-075	Nanogun Airspray H <sub>2</sub> O round spray Ø8 - 7.5 m ( <a href="#">see RT Nr 7117</a> )	1	1	3
	910023071-150	Nanogun Airspray H <sub>2</sub> O round spray Ø8 - 15 m ( <a href="#">see RT Nr 7117</a> )	1	1	3

Item	Part Number	Description	Quantity	Sales unit	Spare parts level (*)
	910023783	ISOCUBE with Nanogun Airspray H <sub>2</sub> O round spray Ø 12 - 7.5 m	1	1	-
	910026044	ISOCUBE with Nanogun Airspray H <sub>2</sub> O round spray Ø 12 - 15 m	1	1	-
1	-	ISOCUBE cabinet equipped ( <a href="#">see § 8.3 page 38</a> )	1	-	-
2	-	Electro-pneumatic box	1	-	-
3	149220760	Stirrer ( <a href="#">see § 8.5 page 44</a> )	Option	1	2
4	-	Pump unit ( <a href="#">see § 8.4 page 42</a> )	1	-	-
5	910023070-075	Nanogun Airspray H <sub>2</sub> O round spray Ø12 - 7.5 m ( <a href="#">see RT Nr 7117</a> )	1	1	3
5	910023070-150	Nanogun Airspray H <sub>2</sub> O round spray Ø12 - 15 m ( <a href="#">see RT Nr 7117</a> )	1	1	3

Item	Part Number	Description	Quantity	Sales unit	Spare parts level (*)
	910023784	ISOCUBE with Nanogun Airspray H2O flat spray - 7.5 m	1	1	-
	910026045	ISOCUBE with Nanogun Airspray H2O flat spray - 15 m	1	1	-
1	-	ISOCUBE cabinet equipped ( <a href="#">see § 8.3 page 38</a> )	1	-	-
2	-	Electro-pneumatic box	1	-	-
3	149220760	Stirrer ( <a href="#">see § 8.5 page 44</a> )	Option	1	2
4	151147500	Pump unit ( <a href="#">see § 8.4 page 42</a> )	1	-	-
5	910023073-075	Nanogun Airspray H2O flat spray - 7.5 m ( <a href="#">see RT Nr 7117</a> )	1	1	3
	910023073-150	Nanogun Airspray H2O flat spray - 15 m ( <a href="#">see RT Nr 7117</a> )	1	1	3

(\*)

Level 1: Standard preventive maintenance.

Level 2: Corrective maintenance.

Level 3: Exceptional maintenance.

### 8.3. ISOCUBE cabinet equipped

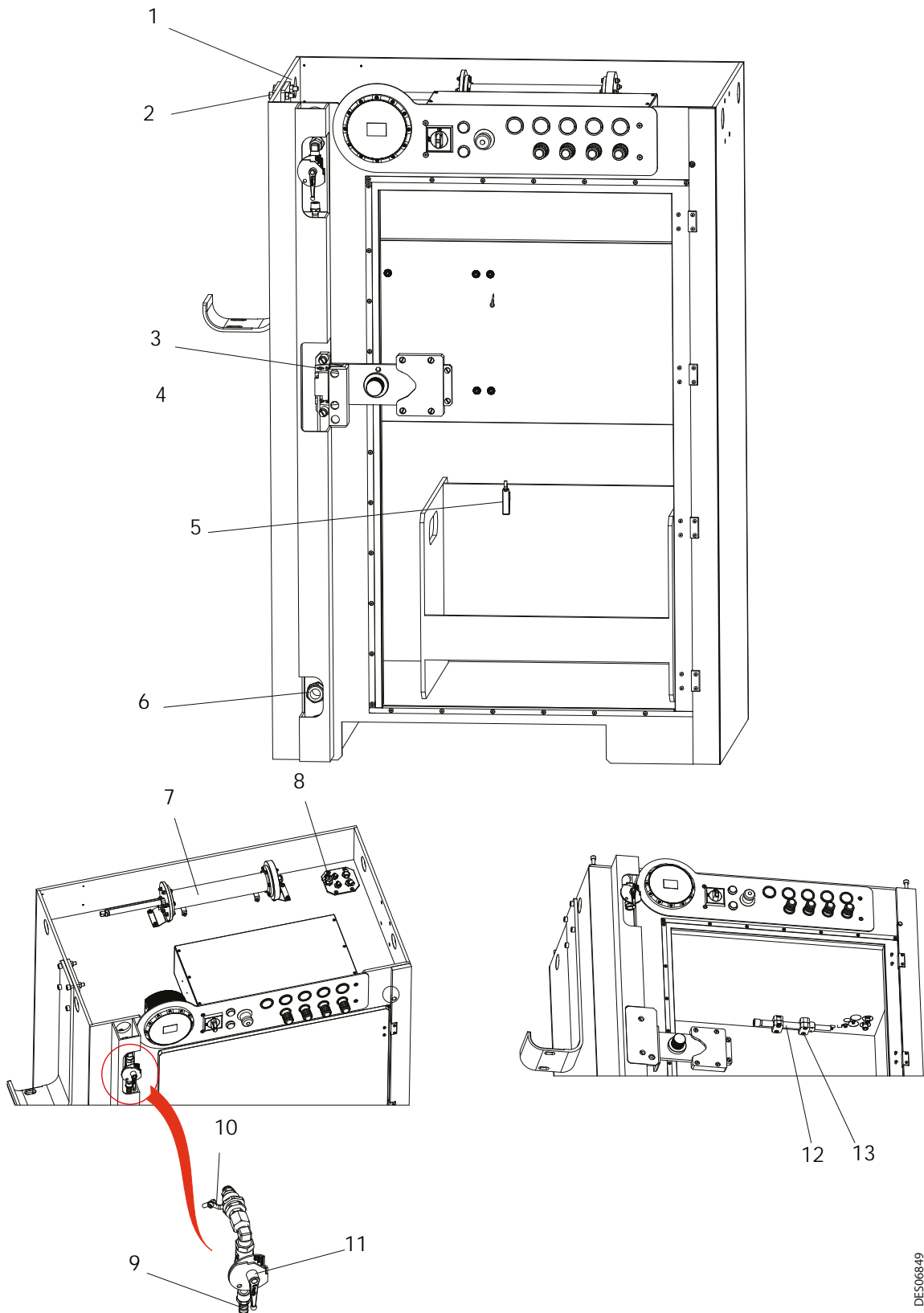

DES06849

Item	Part Number	Description	Quantity	Sales unit	Spare parts level (*)
	-	<b>ISOCUBE cabinet equipped</b>	1	-	-
1	X9SEHU010	H M10 nylon nut containing fibreglass	12	1	3
2	X9SVSY335	Chc M10x50 nylon screw containing fibreglass	8	1	1
3	X9SVCB121	C M 4x16 nylon screw containing fibreglass	8	1	1
4	110002177	Safety switch	1	1	3
5	110001738	Alligator clip 20A	1	1	3
6	110002187AT	Cable gland	1	1	3
7	<b>910020677</b>	<b>Short circuiter (see § 8.3.2 page 39)</b>	1	1	3
8	110000110AT	Cable gland	1	1	3
9	F6RLQF193	Ringed socket	1	1	3
10	900015128	Isolating terminal enclosure	1	1	3
11	F1RBTU073	Ball valve	1	1	3
12	<b>1506262</b>	<b>Discharge resistor (see § 8.3.1 page 38)</b>	1	1	3
13	X9SVCB230	C M6x40 nylon screw containing fibreglass	4	1	1
<b>Not represented</b>					
	U1CBBT117	Polyamide hose D: 2.7/4	-	m	3
	U1CBBT001	Polyamide hose D: 4/6	-	m	3
	U1GLBT142	Polyurethane hose D: 5.5/8	-	m	3
	U1GLBT133	Polyurethane hose D: 7/10	-	m	3
	E2DAVD101	HV cable 100 kV	-	m	1
	842635	Ground cable (length: 5m)	1	1	3

(\*)

Level 1: Standard preventive maintenance.

Level 2: Corrective maintenance.

Level 3: Exceptional maintenance.

### 8.3.1. Discharge resistor

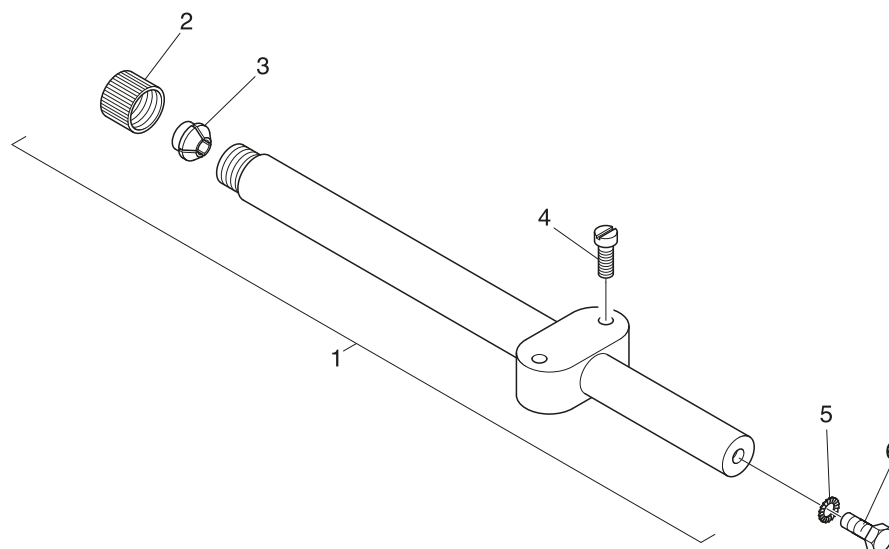

DES00490

Item	Part Number	Description	Quantity	Sales unit	Spare parts level (*)
1	1506262	Discharge resistor		1	1
2	745383	Tightening nut	1	1	1
3	1403346	Tightening socket	1	1	1
4	X9NVCB124	C m 4 / 25 - nylon screw	2	1	3
5	X2BDVX004	Lock washer 4 mm in diameter	1	1	3
6	X3AVSY116	Screw CHC M 4 / 6 - AC zinc plated	1	1	3

(\*)

Level 1: Standard preventive maintenance.

Level 2: Corrective maintenance.

Level 3: Exceptional maintenance.



### 8.3.2. Short circuiter 60kV

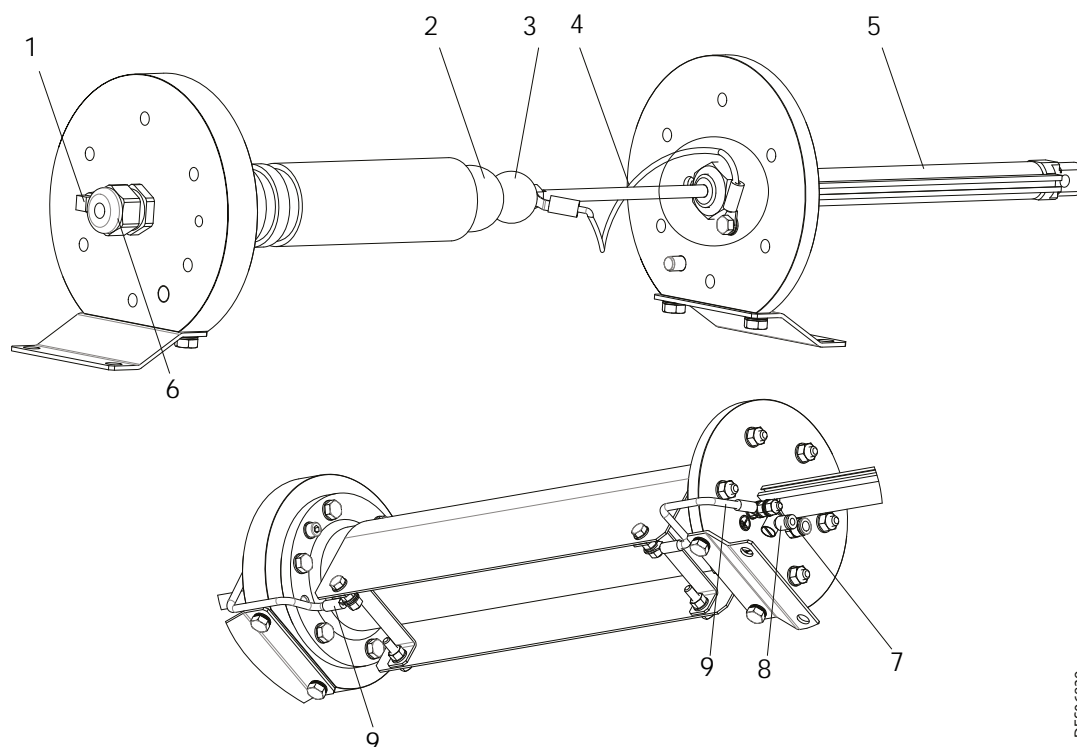

DE506839

Item	Part Number	Description	Qty	Sales unit	Level Spare parts (*)
	<b>910020677</b>	<b>Short circuiter 60 kV</b>	1	1	3
1	F2SSIL053	Exhaust silencer	1	1	2
2	200000304	Stainless steel ball (connected to the high voltage)	1	1	3
3	200000303	Stainless steel ball (connected to the earth)	1	1	3
4	910020672	Earth cable int. cylinder	1	1	3
5	K5VPCA215	Single effect cylinder D: 16 C: 100	1	1	3
6	110000110AT	Cable gland	1	1	3
7	F6RLUS197	Male union	1	1	3
8	F6RLCS270	Male elbow	1	1	3
9	910021321	Earth cable 6mm <sup>2</sup>	2	1	3

Item	Part Number	Description	Qty	Sales unit	Level Spare parts (*)
	<b>910021805</b>	<b>High voltage connection kit</b>	1	1	3
-	U1GCBR041	PTFE hose D: 7/10	0.15	m	3
-	E4CSHT181	HV cable screw tip	1	1	3

(\*)

Level 1: Standard preventive maintenance.

Level 2: Corrective maintenance.

Level 3: Exceptional maintenance.

### 8.4. Pump unit

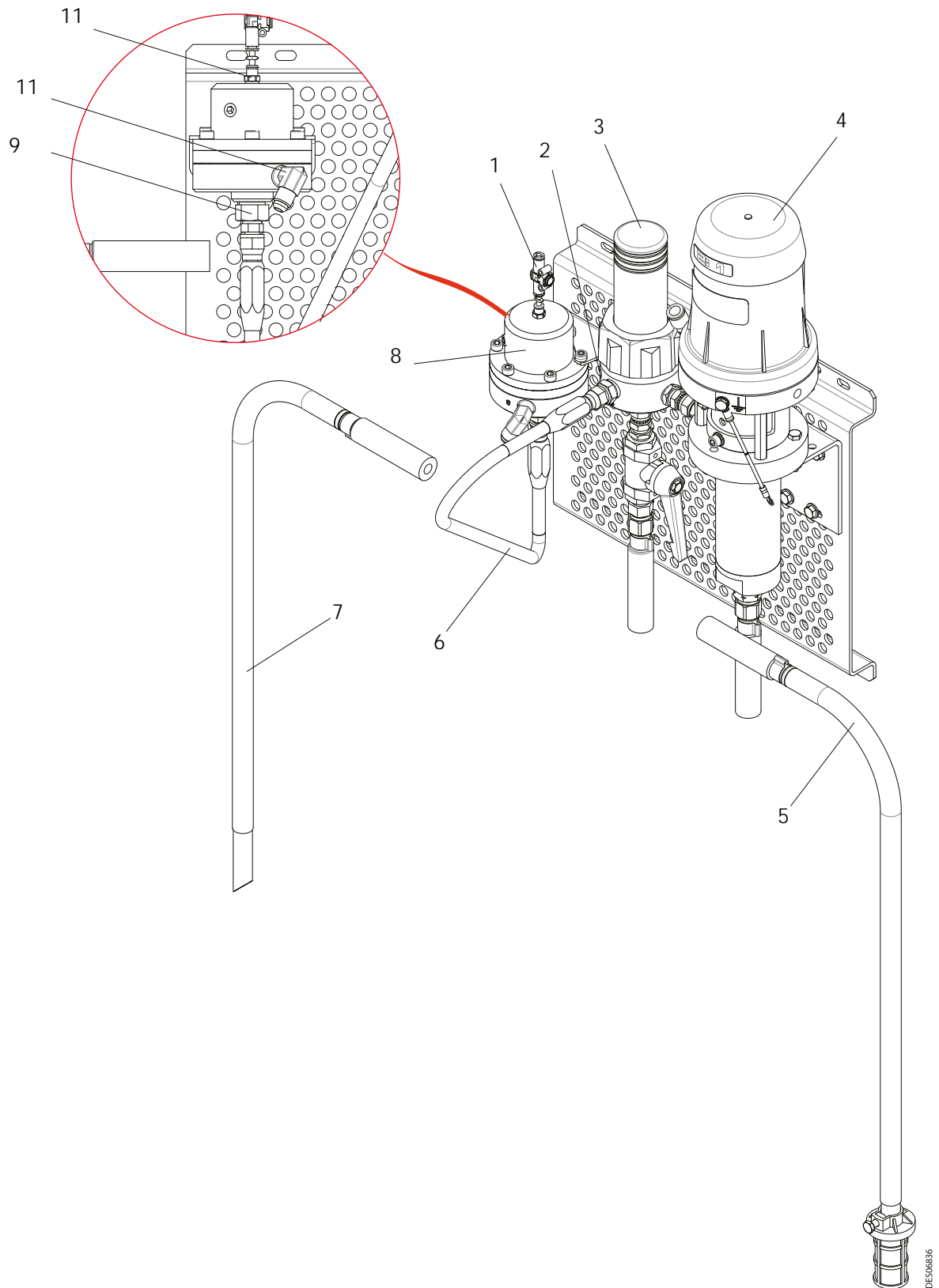

Item	Part Number	Description	Qty	Sales unit	Level Spare parts (*)
	-	Low pressure pump kit	1	-	-
1	155680085	Air Quick exhaust valve, Dia.:4	1	1	3
2	906333102	Hexagon socket plug	1	1	3
3	155580600	Stainless steel fitted filter (See user manual Ref.: 578 001 130 1103)	1	1	2
4	151767100	ISOCUBE pump wall assembly (See user manual Ref.: 578 011 120)	1	1	3
5	049596010	Stainless steel suction tube	1	1	2
6	050450106	Flexible D.: 6	1	1	2
7	049596000	Stainless steel dump tube D.: 16	1	1	2
8	155610230	Product pressure regulator (See user manual ref: 573 025 111.)	1	1	2
9	550636	Male/male stainless steel adapter	1	1	3
10	550596	Elbow adapter	1	1	3
11	905120907	Straight coupler	1	1	3

(\*)

Level 1: Standard preventive maintenance.

Level 2: Corrective maintenance.

Level 3: Exceptional maintenance.

## 8.5. Fitted stirrer (option)

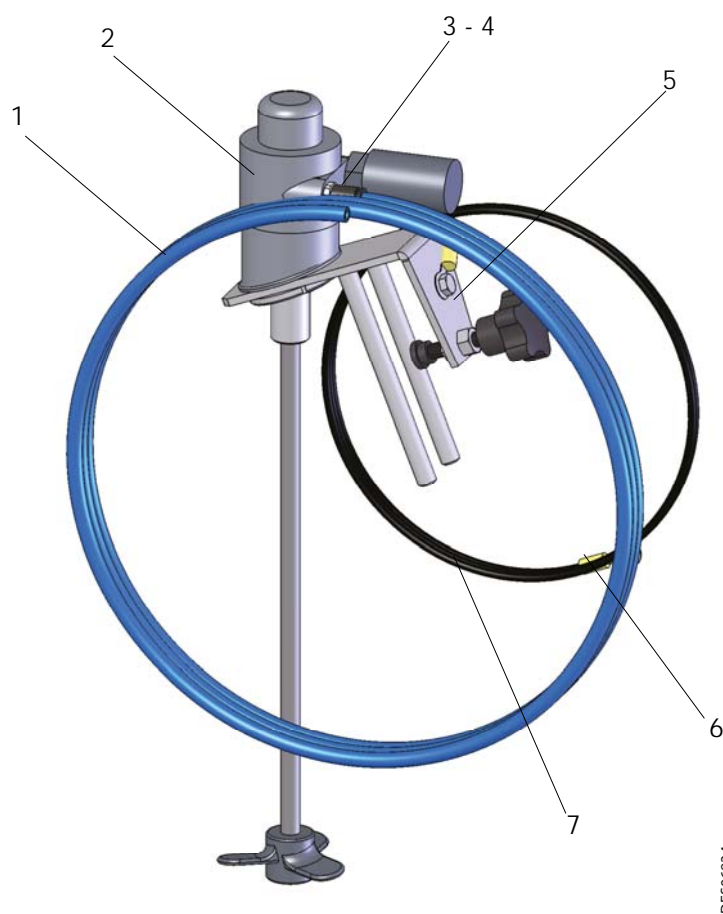

DES06834

Item	Part Number	Description	Qty	Sales unit	Level Spare parts (*)
	<b>149220760</b>	<b>Fitted stirrer</b>	-	<b>1</b>	<b>2</b>
1	539280102	Blue polyurethane hose D.:6x8	1	m	3
2	049220700	Stirrer ( <a href="#">see user manual Ref.: 573 303 050</a> )	1	1	3
3	552486	Female/female sleeve	1	1	2
4	905120904	Straight coupler	1	1	3
5	149220750	ISOCUBE stirrer bracket	1	1	3
6	E4CSPR085	Pre-isolated terminal	2	1	3
7	E2AAMB007	Black wire 6mm <sup>2</sup>	1	1	3

(\*)

Level 1: Standard preventive maintenance.

Level 2: Corrective maintenance.

Level 3: Exceptional maintenance.