



From February 1st, 2017 SAMES Technologies SAS becomes SAMES KREMLIN SAS
A partir du 1/02/17, SAMES Technologies SAS devient SAMES KREMLIN SAS

SAMES  **KREMLIN**



User manual

CS 130 Powder Pump

SAS SAMES Technologies. 13 Chemin de Malacher 38243 Meylan Cedex
Tel. 33 (0)4 76 41 60 60 - Fax. 33 (0)4 76 41 60 90 - www.sames.com

All communication or reproduction of this document, in any form whatsoever and all use or communication of its contents are forbidden without express written authorisation from SAMES Technologies.

The descriptions and characteristics mentioned in this document are subject to change without prior notice.

© SAMES Technologies 2012



WARNING : SAS Sames Technologies is registered with the Ministry of Labour as a training institution.

Throughout the year, our company offers training courses in the operation and maintenance of your equipment.

A catalogue is available on request. Choose from a wide range of courses to acquire the skills or knowledge that is required to match your production requirements and objectives.

Our training courses can be delivered at your site or in the training centre at our Meylan head office.

Training department:

Tel. 33 (0)4 76 41 60 04

E-mail: formation-client@sames.com

SAS Sames Technologies operating manuals are written in French and translated into English, German, Spanish, Italian and Portuguese.

The French version is deemed the official text and Sames will not be liable for the translations into other languages.

CS 130 Powder Pump

1. Warning	4
1.1. <i>Marking</i>	4
1.2. <i>Simplified analysis of the potential sources of ignition according to Standard EN 13463-1</i>	4
2. Description	5
3. General characteristics	5
3.1. <i>Pneumatical characteristics</i>	5
3.2. <i>Indicative flow characteristics</i>	6
3.2.1. <i>Powder flow with a Dia. 11 mm tube</i>	6
3.2.2. <i>Powder flow with a Dia. 12 mm tube</i>	6
4. Working characteristics	7
5. Equipment installation	7
6. Powder pump adjustment	7
7. Maintenance	8
7.1. <i>"Venturi" assembly tube (ejector)</i>	8
7.1.1. <i>Dismantling</i>	8
7.1.2. <i>Reassembling</i>	8
7.2. <i>Injector</i>	9
7.2.1. <i>Dismantling</i>	9
7.2.2. <i>Re-assembling</i>	9
7.3. <i>Re-assembly of the air injector</i>	9
8. Troubleshooting	9
9. Spare parts	10
9.1. <i>CS 130 pump, powder version</i>	10
9.1.1. <i>Equipped Venturi ejector</i>	11
9.1.2. <i>Equipped injector</i>	11
9.2. <i>CS 130 pump, air version (fumes evacuation)</i>	12
9.3. <i>Connections</i>	13

1. Warning



WARNING : Connect the CS 130 pump to the ground by using the conductive o-rings of the aspiration tube which must itself be connected to the ground via its conductive base-plate.

1.1. Marking

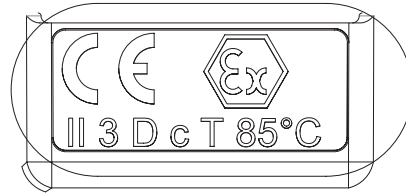

DES05447

1.2. Simplified analysis of the potential sources of ignition according to Standard EN 13463-1

Risk of ignition		Action applied to prevent any ignition source to become effective
Potential source of ignition	Description / Main cause (What are the conditions engendering the ignition risk?)	Description of the applied action
Static electricity	Triboelectric charges by powder circulation in the hose in pump outlet	Pump in conductive materials. Base plate of the plunger tubes conducting provided with o-rings conducting and connected to the ground Groundings of the equipment to be realized imperatively in accordance with the safety and installation rules.

2. Description

New generation the CS130 pump is a very easy pump of use. Its maintenance is very fast and well to do, and requires no specific tools.

Its metal body allows a cleaning with solvent by having previously removed all the associated components.

The powder outlet end piece is conductive to improve the evacuation of possible generated triboelectric charges.

The CS 130 pump is a Venturi-effect pump:

1	Injection
2	Dilution
3	Powder output
3	Powder input

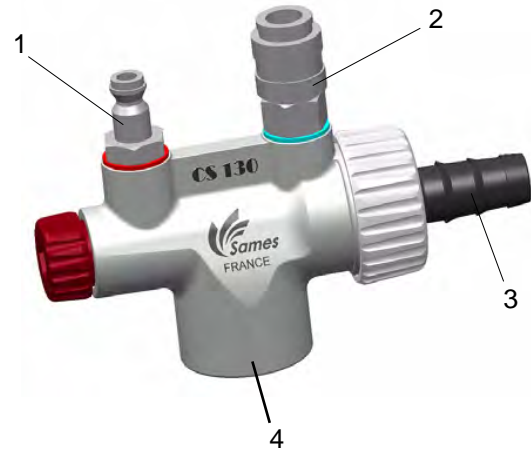

3. General characteristics

3.1. Pneumatical characteristics

To ensure a correct running of the equipment, the following pneumatical characteristics are required according to the NF ISO 8573-1 standard :

Maximum dew point at 6 bar (90 psi)	class 4 : + 3 °C (38 °F)
Maximum granulometry of solid polluting agents	class 3 : 5 µm.
Maximum oil concentration	class 1 : 0,01 mg / m ₀ ³ *
Maximum concentration of solid pollutant agents	class 3 : 5 mg / m ₀ ³ *

* : values are given for a temperature of 20 °C (68 °F), at the 1013 mbar atmospheric pressure.

3.2. Indicative flow characteristics

The CS 130 powder pump is connected to an projector or to a powdering gun.

3.2.1. Powder flow with a Dia. 11 mm tube

With an int Dia. 11 mm powder transport tube and dilution air adjusted as advised [see § 6 page 7](#) , characteristics are the following, according to the length of the tube:

A	Injection air flow (m_0^3/h *)
B	Powder flow (g/min)
C	Injection air pressure (bar)
D	Transport tube length : 10 m
E	Transport tube length : 8 m
F	Transport tube length : 6 m
G	Transport tube length : 4 m

* m_0^3/h : volumic flow at atmospheric pressure and at 20 °C (68 °F).

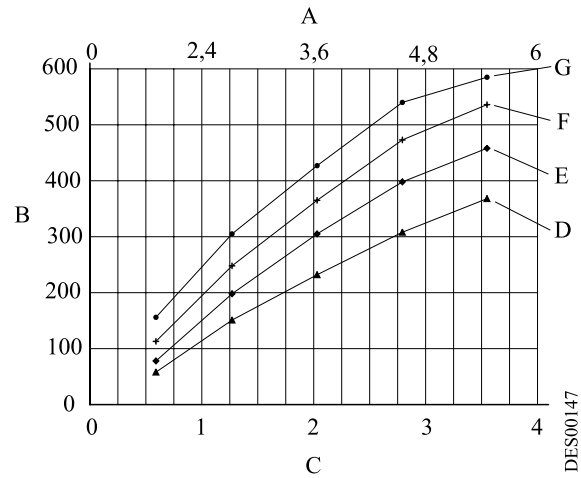

3.2.2. Powder flow with a Dia. 12 mm tube

With an int Dia. 12 mm powder transport tube and dilution air adjusted as advised, [see § 6 page 7](#) , characteristics are the following, according to the length of the tube:

A	Injection air flow (m_0^3/h *)
B	Powder flow (g/min)
C	Injection air pressure (bar)
D	Transport tube length : 10 m
E	Transport tube length : 8 m
F	Transport tube length : 6 m
G	Transport tube length : 4 m

* m_0^3/h : volumic flow at atmospheric pressure and at 20 °C (68 °F).

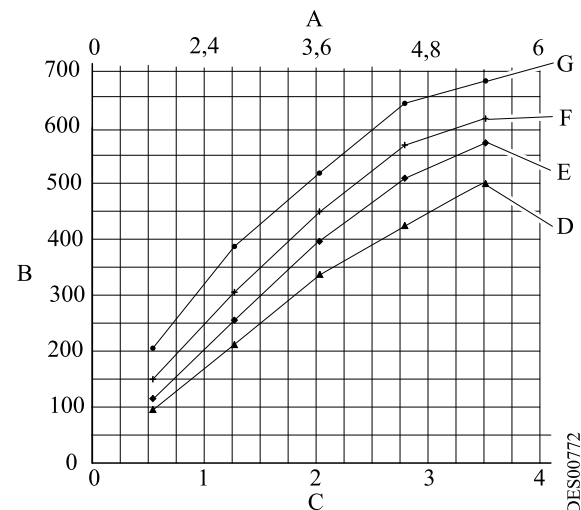

WARNING : The maximum lengths of powder transport tube advised are the following:

- 10 m for a Dia. 11 mm tube
- 15 m for a Dia. 12 mm tube

Injection air pressure should not be over 3 bar in order to prevent from a too early wear.

4. Working characteristics

The powder pump is a Venturi-effect pump; a high-speed blast of air (powered in [1] - called "injection" air) drives the fluidized powder to the projector through a powder transport tube connected to a powder outlet end piece [3]. To ensure the regularity of low powder flow rates, additional air called "dilution" air can be added in the powder pump (in [2]).

The flow of powder provided by the powder pump varies with:

- the pressure of the "injection" air,
- the pressure of the "dilution" air,
- the length and the diameter of the powder transport tube,
- the height of the powder in the tank.
- the wear of Venturi ejector tube

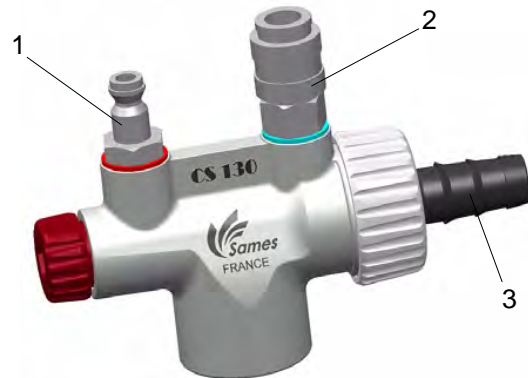

5. Equipment installation

Install the powder pump as per the following:

- As near as possible from the projector or the gun.
- Suction tube equipped with conductive o-rings.
- Limiting the curves of the powder transport tube.

6. Powder pump adjustment

Actions listed here below give the following results:

Action	Result
Injection air pressure increased	Powder flow increased
Dilution air pressure increased	Powder flow decreased
Powder transport tube length increased	Powder flow decreased
Powder transport tube diameter increased	Powder flow increased
Height of the powder in the tank increased	Powder flow increased

7. Maintenance



WARNING : Cleaning must only be done using compressed air, except for the metal body and for the injector, with a cloth or possibly a brush. Never use water to clean the equipment.



WARNING : The cleaning of the body and the metal injector can be carried out with solvent in the following conditions:

- all the components fitted on the body must be removed.
- Withdraw the injector from the injector holder and remove its o-ring.

The maintenance schedule indicated below is a rough guide. According to the use of the SAMES equipment is used, the user should draw up his own maintenance schedule.

To begin with we recommend the following maintenance schedule:



WARNING : In order to avoid any pollution to the supply module, the "injection" air tubes and the "dilution" air tubes must be disconnected before cleaning the powder pump.

Maintenance frequency	Action
Between 40 and 60 hours of work	Check that the Venturi assembly tube is clean and not worn, clean or replace it if necessary. Check that the powder pump injector is clean. If it is dirty, clean it.

7.1. "Venturi" assembly tube (ejector)

7.1.1. Dismantling

- Remove the powder outlet end piece by unscrewing the powder connection nut ([see § 9 page 10](#)).
- Extract the "Venturi" assembly tube.



WARNING : It is not necessary to disconnect the powder tube from the powder end piece.

7.1.2. Reassembling



WARNING : Check that the o-ring is in place. If not damaged, and replace if necessary.

- Put in place the venturi assembly tube into the CS 130 body.
- Install the powder outlet end piece into the body and screw the connection nut.

7.2. Injector

7.2.1. Dismantling

- Unscrew the injector.
- Extract the injector from the body. Check that the o-rings and the injector are not damaged, clean and replace if necessary.



WARNING : Check the wear of the injector, this one should neither be blocked neither be dirty nor be worn. Remove possible deposit.

7.2.2. Re-assembling

- Put in place the injector into the body .
- Screw .

7.3. Re-assembly of the air injector

- Put the air injector (7) in the pump body.
- Screw the fitting (8) back in place.

8. Troubleshooting

Symptoms	Probable causes	Remedies
The powder does not come out of the gun.	Insufficient "injection" air flow.	Refer to the settings of the module
	Insufficient air flow from the compressed air system.	Refer to the settings of the module
	The powder transport tube is blocked or bended	Clean the powder transport tube with compressed air.
	The powder pump is not correctly connected to its support.	Put the powder pump properly into place by pushing it to the bottom of its support.
The powder comes out in an insufficient quantity.	The powder pump "venturi" ejector is worn out.	Change "venturi" ejector.
	The powder transport tube is partially blocked or bended.	Clean the powder transport tube with compressed air.
	The powder transport tube is not properly adapted.	Increase the diameter and shorten the length of the powder transport hose (e.g. 3m, Dia. 11 mm).
	The flow of the "dilution" air is too high.	Adjust the flow of the "dilution" air.
Irregular powder pattern	Worn parts of the CS 130	Change worn parts (injector, venturi ejector) see § 9 page 10
	The flow of the "dilution" air is not high enough.	Increase the dilution air flow

9. Spare parts

9.1. CS 130 pump, powder version

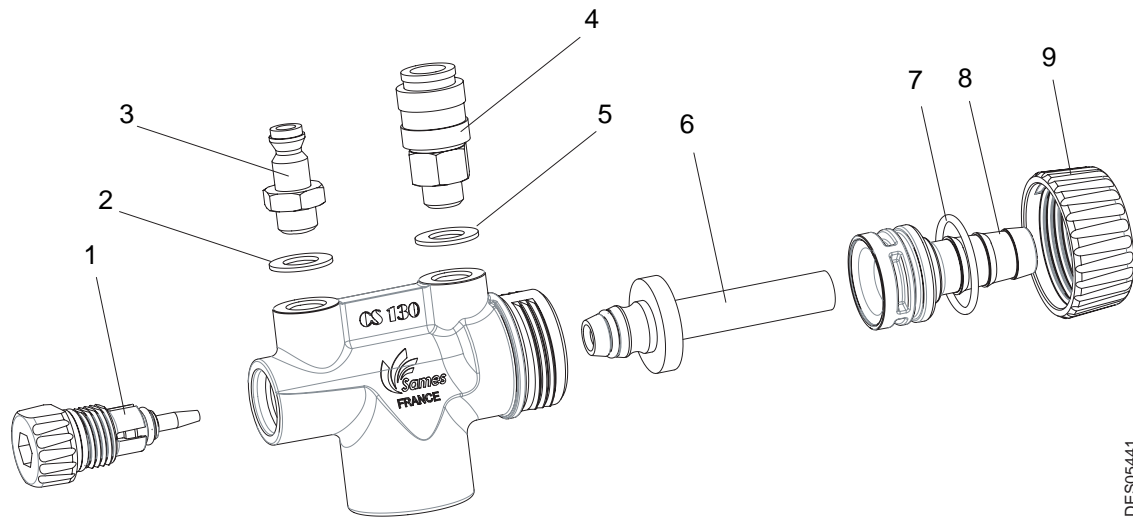

DES05441

Item	Part Number	Description	Qty	Unit of Sale	Level for Spare part (*)
	910013775	CS 130 pump, powder version	1	1	3
1	910014564	Equipped metal injector (see § 9.1.2 page 11)	1	1	2
	910014565	Equipped plastic injector (see § 9.1.2 page 11)	Option	1	1
2	EU9000853	Red washer 1/8" BSP	1	1	3
3	EU9001083	Male union 1/8" BSP	1	1	3
4	F6RAJR025	Coupling union 1/8" BSP	1	1	3
5	EU9000854	Blue washer 1/8" BSP	1	1	3
6	910014388	Equipped grey venturi ejector (see § 9.1.1 page 11)	1	1	1
	910014390	Equipped white venturi ejector (see § 9.1.1 page 11)	Option	1	1
7	J2FTDF273	O-ring - black viton	1	1	1
8	900008907	Powder outlet end piece	1	1	3
9	900008904	Powder connection nut	1	1	3

(*)

Level 1: Standard preventive maintenance

Level 2: Corrective maintenance

Level 3: Exceptional maintenance



WARNING : The white venturi ejector (P/N: 910014390) is to be used with low particle size of powder, or with powder with low impact fusion characteristics.

9.1.1. Equipped Venturi ejector

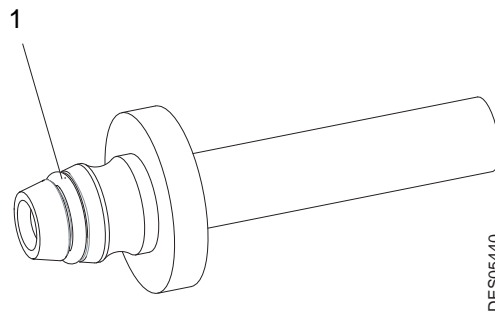

Item	Part Number	Description	Qty	Unit of Sale	Level for Spare part (*)
	910014388	Equipped grey venturi ejector	1	1	1
	910014390	Equipped white venturi ejector	Option	1	1
1	160000146	Black o-ring	1	1	1

(*)

Level 1: Standard preventive maintenance

Level 2: Corrective maintenance

Level 3: Exceptional maintenance

9.1.2. Equipped injector

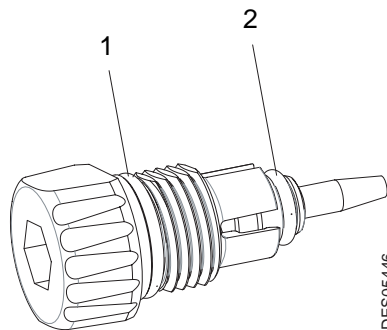

Item	Part Number	Description	Qty	Unit of Sale	Level for Spare part (*)
	910014564	Equipped metal injector	1	1	2
	910014565	Equipped plastic injector	Option	1	1
1	J2FTDF160	O-ring - black viton	1	1	1
2	J2FTDF075	O-ring - black viton	1	1	1

(*)

Level 1: Standard preventive maintenance

Level 2: Corrective maintenance

Level 3: Exceptional maintenance

9.2. CS 130 pump, air version (fumes evacuation)

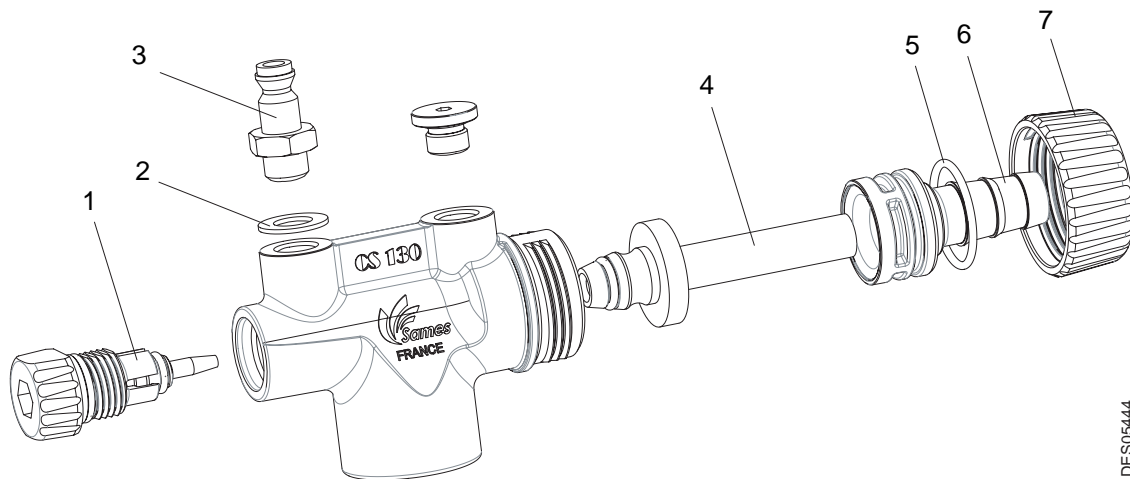

DES05444

Item	Part Number	Description	Qty	Unit of Sale	Level for Spare part (*)
	910014333	CS 130 pump, air version	1	1	3
1	910014564	Equipped metal injector (see § 9.1.2 page 11)	1	1	2
2	EU9000855	Black washer 1/8 BSP	1	1	3
3	EU9001083	Male union 1/8" BSP	1	1	3
4	910014388	Equipped grey venturi ejector (see § 9.1.1 page 11)	1	1	1
5	J2FTDF273	O-ring - black viton	1	1	1
6	900008907	Powder outlet end piece	1	1	3
7	900008904	Powder connection nut	1	1	3

(*)

Level 1: Standard preventive maintenance

Level 2: Corrective maintenance

Level 3: Exceptional maintenance

9.3. Connections

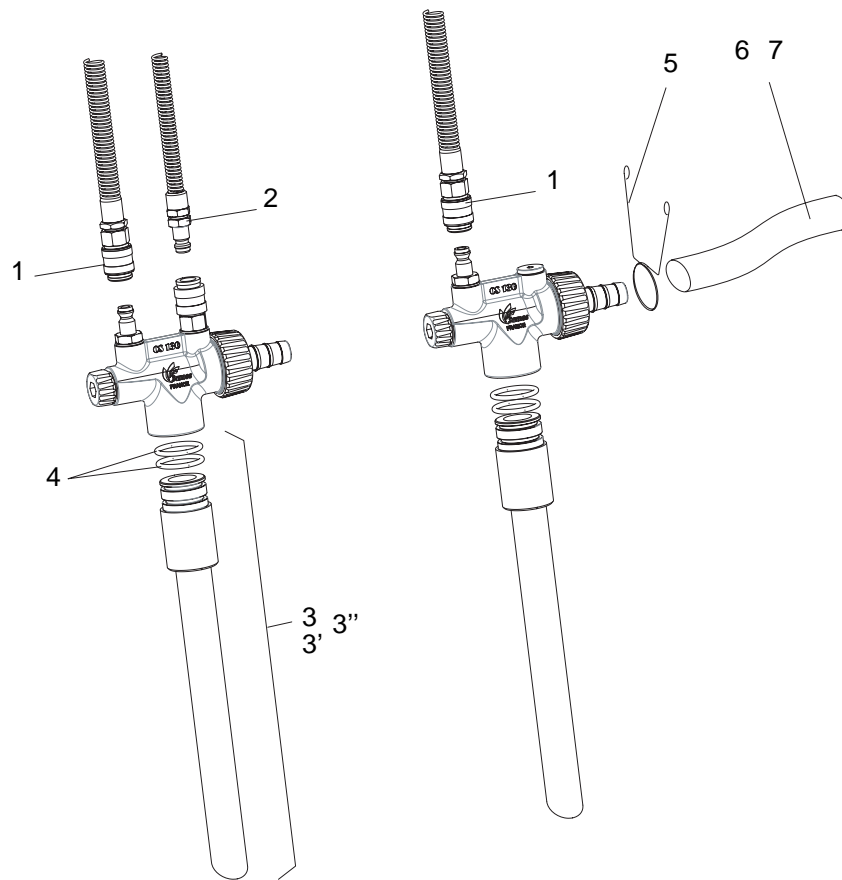

DES05445

Item	Part Number	Description	Qty	Unit of Sale	Level for Spare part (*)
1	130001143	Female union, injection 8mm	1/CS130	1	3
2	130001142	Male union, dilution 6 mm	1	1	3
3	910008159	Smooth tube for tanks on carriage	1	1	3
3'	1526399	Smooth tube for CSV 600 tank	-	1	3
3"	910014627	Smooth tube for PVV booth only (for CS 130 only)	-	1	3
4	J2CTPB253	Conductive o-rings	2	1	1
5	1406394	Powder hose tightening clamp	-	1	3
6	U1FGBA092	EAV colorless powder hose, 11 mm **	-	m	2
7	130001030	POE red powder hose, 11 mm **	-	50 m	2
8	U1FGBA034	EAV grey powder hose, 12 mm **	-	50 m	2

(*)

Level 1: Standard preventive maintenance

Level 2: Corrective maintenance

Level 3: Exceptional maintenance

**** To select the diameter of powder hose, contact Sames Technologies.**