



DOCUMENTATION - DOKUMENTATION - DOCUMENTACIÓN

UNITE D'AGITATION / AGITATION UNITS / RÜHRWERK / UNIDAD DE AGITACIÓN

CYCLIX II

40 L

Notice / Manual / Betriebsanleitung / Libro : 582.011.110 - 1605

Date / Datum / Fecha : 23/05/16

Annule / Supersede / Ersetzt / Anula :

Modif. / Änderung :

NOTICE ORIGINALE / TRANSLATION FROM THE ORIGINAL MANUAL
/ ÜBERSETZUNG DER ORIGINAL BETRIEBSANLEITUNG
/ TRADUCCIÓN DEL MANUAL ORIGINAL

IMPORTANT : Lire attentivement tous les documents avant le stockage, l'installation ou la mise en service du matériel concerné (à usage strictement professionnel).

Before assembly and start-up, please read and clearly understand all the documents relating to this equipment (professional use only).

WICHTIGER HINWEIS: Vor Lagerung, Installation oder Inbetriebnahme des Geräts bitte sämtliche Dokumente sorgfältig lesen (Einsatz nur von geschultem Personal).

IMPORTANTE : Lea con atención todos los documentos antes de almacenar, instalar o poner en marcha el equipo (uso exclusivamente profesional).

PHOTOS ET ILLUSTRATIONS NON CONTRACTUELLES. MATERIELS SUJETS A MODIFICATION(S) SANS PREAVIS.

THE PICTURES AND DRAWINGS ARE NON CONTRACTUAL. WE RESERVE THE RIGHT TO MAKE CHANGES WITHOUT PRIOR NOTICE.

ALLE IN DIESEM DOKUMENT ENTHALTENEN SCHRIFTLICHEN ANGABEN UND ABBILDUNGEN STELLEN DIE NEUESTEN

PRODUKTINFORMATIONEN DAR. WIR BEHALTEN UNS DAS RECHT VOR, JEDERZEIT OHNE VORANKÜNDIGUNG ÄNDERUNGEN VORZUNEHMEN.

LAS FOTOGRAFÍAS E ILUSTRACIONES NO SON VINCULANTES. LOS MATERIALES ESTÁN SUJETOS A CAMBIOS SIN PREVIO AVISO.

KREMLIN - REXSON

150, avenue de Stalingrad

93 245 - STAINS CEDEX - France

☎ : 33 (0)1 49 40 25 25 Fax : 33 (0)1 48 26 07 16

www.kremlin-rexson.com



<p align="center">FR</p> <p>Pour une utilisation sûre, il est de votre responsabilité de :</p> <ul style="list-style-type: none"> • Lire attentivement tous les documents contenus dans le CD joint avant la mise en service de l'équipement, • D'installer, d'utiliser, d'entretenir et de réparer l'équipement conformément aux préconisations de KREMLIN REXSON ainsi qu'aux réglementations nationales et/ou locales, • Vous assurez que les utilisateurs de cet équipement ont été formés, ont parfaitement compris les règles de sécurité et qu'ils les appliquent. 	<p align="center">UK</p> <p>To ensure safe use of the machinery, it is your responsibility to:</p> <ul style="list-style-type: none"> • Carefully read all documents contained on the enclosed CD before putting the machinery into service, • Install, use, maintain and repair the machinery in accordance with KREMLIN REXSON's recommendations and national and/or local regulations, • Make sure that the users of the machinery have received proper training and that they have perfectly understood the safety rules and apply them. 	<p align="center">DE</p> <p>Eine sichere Nutzung setzt voraus, dass Sie: :</p> <ul style="list-style-type: none"> • alle in der CD enthaltenen Dokumente vor der Inbetriebnahme der Anlage aufmerksam lesen, • die Anlage im Einklang mit den Empfehlungen von KREMLIN REXSON sowie mit den nationalen und/oder lokalen Bestimmungen installieren, verwenden, warten und reparieren, • sich vergewissern, dass die Nutzer dieser Anlage angemessen geschult wurden, die Sicherheitsbestimmungen verstanden haben und sie anwenden.
<p align="center">ES</p> <p>Para una utilización segura, será de su responsabilidad:</p> <ul style="list-style-type: none"> • leer atentamente todos los documentos que se incluyen en el CD adjunto antes de la puesta en servicio del equipo, • instalar, utilizar, efectuar el mantenimiento y reparar el equipo con arreglo a las recomendaciones de KREMLIN REXSON y a la normativa nacional y/o local, • cerciorarse de que los usuarios de este equipo han recibido la formación necesaria, han entendido perfectamente las normas de seguridad y las aplican. 	<p align="center">IT</p> <p>Per un uso sicuro, vi invitiamo a:</p> <ul style="list-style-type: none"> • leggere attentamente tutta la documentazione contenuta nel CD allegato prima della messa in funzione dell'apparecchio, • installare, utilizzare, mantenere e riparare l'apparecchio rispettando le raccomandazioni di KREMLIN REXSON, nonché le normative nazionali e/o locali, • accertarvi che gli utilizzatori dell'apparecchio abbiano ricevuto adeguata formazione, abbiano perfettamente compreso le regole di sicurezza e le applichino. 	<p align="center">PT</p> <p>Para uma utilização segura, é da sua responsabilidade:</p> <ul style="list-style-type: none"> • Ler atentamente todos os documentos incluídos no CD em anexo antes de pôr o equipamento em funcionamento, • Proceder à instalação, utilização, manutenção e reparação do equipamento de acordo com as preconizações de KREMLIN REXSON, bem como com outros regulamentos nacionais e/ou locais aplicáveis, • Assegurar-se que os utilizadores do equipamento foram devidamente capacitados, compreenderam perfeitamente e aplicam as devidas regras de segurança.
<p align="center">NL</p> <p>Voor een veilig gebruik dient u:</p> <ul style="list-style-type: none"> • alle document op de bijgevoegde cd aandachtig te lezen alvorens het apparaat in werking te stellen, • het apparaat te installeren, gebruiken, onderhouden en repareren volgens de door KREMLIN REXSON gegeven aanbevelingen en overeenkomstig de nationale en/of plaatselijke reglementeringen, • zeker te stellen dat de gebruikers van dit apparaat zijn opgeleid, de veiligheidsregels perfect hebben begrepen en dat zij die ook toepassen. 	<p align="center">SE</p> <p>För en säker användning av utrustningen ansvarar ni för följande:</p> <ul style="list-style-type: none"> • Läs noga samtliga dokument som finns på den medföljande cd-skivan innan utrustningen tas i drift. • Installera, använd, underhåll och reparera utrustningen enligt anvisningarna från KREMLIN REXSON och enligt nationella och/eller lokala bestämmelser. • Försäkra er om att användare av denna utrustning erhållit utbildning, till fullo förstått säkerhetsföreskrifterna och tillämpar dem. 	<p align="center">FI</p> <p>Käytön turvallisuuden varmistamiseksi velvollisuutesi on:</p> <ul style="list-style-type: none"> • Lukea huolella kaikki CD:llä olevat asiakirjat ennen laitteiston käyttöönottoa, • Noudattaa laitteiston asennuksessa, käytössä, kunnossapidossa ja huollossa KREMLIN REXSON in suosituksia sekä kansallisia ja/tai paikallisia määräyksiä, • Varmistaa, että laitteiston käyttäjät ovat koulutettuja ja ymmärtävät täysin turvallisuusmääräykset ja miten niitä sovelletaan.
<p align="center">PL</p> <p>Dla zapewnienia bezpiecznego użytkowania na użytkownika spoczywa obowiązek:</p> <ul style="list-style-type: none"> • Uważnego zapoznania się ze wszystkimi dokumentami znajdującymi się na załączonej płycie CD przed pierwszym uruchomieniem urządzenia, • Instalowania, użytkowania, konserwacji i naprawy urządzenia zgodnie z zaleceniami firmy KREMLIN REXSON oraz z przepisami miejscowymi, • Upewnienia, że wszyscy przeszkoleni użytkownicy urządzenia zrozumieli zasady bezpieczeństwa i stosują się do nich. 	<p align="center">CS</p> <p>Pro bezpečné používání jste povinni:</p> <ul style="list-style-type: none"> • Před uvedením zařízení do provozu si pozorně přečíst veškeré dokumenty obsažené na příloženém CD, • Nainstalovat, používat, udržovat a opravovat zařízení v souladu s pokyny firmy KREMLIN REXSON a s národními a/nebo místními legislativními předpisy, • Ujistit se, že uživatelé tohoto zařízení byli vyškoleni, že dokonale pochopili bezpečnostní pravidla a že je dodržují. 	<p align="center">RU</p> <p>Для целей безопасного использования необходимо:</p> <ul style="list-style-type: none"> • Ознакомиться со всеми документами, содержащимися в прилагаемом компакт-диске до ввода оборудования в эксплуатацию; • Устанавливать, использовать, производить техническое обслуживание и ремонт оборудования в соответствии с рекомендациями KREMLIN REXSON и национальным и/или местным законодательством; • Убедиться, что пользователи настоящего оборудования прошли подготовку, надлежащим образом усвоили правила безопасности и обеспечивают их соблюдение.

Déclaration(s) de conformité au verso de ce document / Declaration(s) of conformity at the back of this document / Konformitätserklärung(en) auf der Rückseite dieser Unterlage / Declaración (es) de conformidad en el reverso de este documento / Dichiarazione/i di conformità sul retro del presente documento / Declaração(ões) de conformidade no verso do documento / Conformiteitsverklaring(en) op de keerzijde van dit document / Försäkran om överensstämmelse på omstående sida av detta dokument / Vaatimustenmukaisuusvakuutukset tämän asiakirjan kääntöpuolella / Deklaracja(e) zgodności na odwrocie dokumentu / Prohlášení o shodě se nachází/nacházejí na zadní straně tohoto dokumentu / Сертификат(ы) соответствия расположены на оборотной стороне настоящего документа

VALABLE JUSQU'AU 19 AVRIL 2016
VALID UNTIL 19 APRIL 2016
GÜLTIG BIS ZUM 19. APRIL 2016
VALIDEZ HASTA EL 19 DE ABRIL DE 2016
VALIDO FINO AL 19 APRILE 2016
APLICÁVEL ATÉ 19 DE ABRIL DE 2016
GELDIG TOT 19 APRIL 2016
GÄLLER TILL OCH MED DEN 19 APRIL 2016
VOIMASSA 19.4.2016 SAAKKA
WAŻNOŚĆ DO 19 KWIETNIA 2016 R.
PLATÍ DO 19. DUBNA 2016
ДЕЙСТВИТЕЛЬНО ДО 19 АПРЕЛЯ 2016 ГОДА



DECLARATION CE DE CONFORMITE
EC DECLARATION OF CONFORMITY
EG KONFORMITÄTSEKTLÄRUNG
DECLARACIÓN CE DE CONFORMIDAD
DICHIARAZIONE CE DI CONFORMITÀ
DECLARAÇÃO CE DE CONFORMIDADE
EG-VERKLARING VAN OVEREENSTEMMING
EG-FÖRSÄKRAN OM ÖVERENSSTÄMMELSE
EY-VAATIMUKSEN MUKAISUUSVAKUUTUS
DEKLARACJA ZGODNOŚCI CE
CE PROHLÁŠENÍ O SHODĚ
ДЕКЛАРАЦИЯ СООТВЕТСТВИЯ CE

Le fabricant / The manufacturer / Der Hersteller / El fabricante / Il produttore / O fabricante / De fabrikant / Tillverkare / Valmistaja / Producent / Výrobce / Изготовитель:	KREMLIN REXSON 150, avenue de Stalingrad 93 240 - STAINS - FRANCE Tél. 33 (0)1 49 40 25 25 - Fax : 33 (0)1 48 26 07 16
--	--

Déclare que le matériel désigné ci-après / Herewith declares that the equipment / erklärt hiermit, dass die / Declara que el material designado a continuación / Dichiaro che il materiale sottoindicato / Declara que o material a seguir designado / verklaart dat de hieronder aangeduide apparatuur / Kungör att den utrustning som anges här nedan / ilmoittaa, että alla mainitut laitteistot / Oświadcza, że wymienione poniżej urządzenia / Prohlašuje, že níže uvedené vybavení / Декларирует, что нижеуказанное оборудование:

**ENSEMBLE D'AGITATION / AGITATOR UNIT / RÜHRANLAGE / CONJUNTO DE AGITACIÓN
- CYCLIX II**

POUR FUTS DE 40 LITRES / FOR 40 L / 10.6 US GAL DRUMS / FÜR 40 LITRE-FASS / PARA RECIPIENTES DE 40 LITROS
POUR FUTS DE 200 LITRES / FOR 200 L / 52.8 US GAL DRUMS / FÜR 200 LITER-FASS / PARA RECIPIENTES DE 200 LITROS

Est conforme à la législation d'harmonisation de l'Union applicable suivante / Is in conformity with the relevant Union harmonisation legislation / Erfüllt die einschlägigen Harmonisierungsrechtsvorschriften der Union / es conforme con la legislación de armonización pertinente de la Unión / è conforme alla pertinente normativa di armonizzazione dell'Unione / in overeenstemming met de desbetreffende harmonisatiewetgeving van de Unie / med den relevanta harmoniserade unionslagstiftningen / on asiaa koskevan unionin yhdenmukaistamislainsäädännön vaatimusten mukainen / jest zgodny z odpowiednimi wymaganiami unijnego prawodawstwa harmonizacyjnego / Shoduje se s následující příslušnou evropskou harmonizační legislativou / Соответствует следующим стандартизированным нормам Союза

Directive ATEX / ATEX Directive / ATEX Richtlinie / Directiva ATEX / Direttiva ATEX / Diretiva ATEX / ATEX-Richtlijn / ATEX-direktivet / ATEX-direktivi / Dyrektywa ATEX / Směrnice ATEX / Директива ATEX	 II 2G c T5	94/9/CE
EN 13463-5:2011 Protection par sécurité de construction "c" - Protection by constructional safety "c"		

Dominique LAGOUGE

Directeur Général / Chief Executive Officer / Generaldirektor
/ Director General / Direttore Generale / Director Geral / Algemeen
Directeur / Generaldirektör / Pääjohtaja / Dyrektor Naczelny
/ Dyrektor Generalny / Generální ředitel / Генеральный директор

Fait à Stains, le / Established in Stains, on / Geschehen zu Stains, am / En Stains, a / Redatto a Stains, / Vastgesteld te Stains, / Utformat i Stains, den / Stains, Ranska, / Sporządzono w Stains, dnia / Stains, dnia / Издано в г. Стен (Stains) 04/09/2014 - 04/09/2014

VALABLE A PARTIR DU 20 AVRIL 2016
VALID FROM 20 APRIL 2016
GÜLTIG AB DEM 20. APRIL 2016
VALIDEZ A PARTIR DEL 20 DE ABRIL DE 2016
VALIDO A PARTIRE DAL 20 APRILE 2016
APLICÁVEL A PARTIR DE 20 DE ABRIL DE 2016
GELDIG VANAF 20 APRIL 2016.
GÄLLER FRÅN OCH MED DEN 20 APRIL 2016
VOIMASSA 20.4.2016 ALKAEN
WAŻNOŚĆ OD 20 KWIETNIA 2016 R.
PLATÍ OD 20. DUBNA 2016
ДЕЙСТВИТЕЛЬНО С 20 АПРЕЛЯ 2016 ГОДА



DECLARATION UE DE CONFORMITE
UE DECLARATION OF CONFORMITY
EU-KONFORMITÄTSEKTLÄRUNG
DECLARACIÓN UE DE CONFORMIDAD
DICHIARAZIONE DI CONFORMITÀ UE
DECLARAÇÃO UE DE CONFORMIDADE
EU-CONFORMITEITSVERKLARING
EU-FÖRSÄKRAN OM ÖVERENSSTÄMMESE
EU-VAATIMUKSEN MUKAISUUSVAKUUTUS
DEKLARACJA ZGODNOŚCI UE
EU PROHLÁŠENÍ O SHODĚ
ДЕКЛАРАЦИЯ О СООТВЕТСТВИИ НОРМАМ ЕС

Le fabricant / The manufacturer / Der Hersteller / El fabricante / Il produttore / O fabricante / De fabrikant / Tillverkare / Valmistaja / Producent / Výrobce / Изготовитель:	KREMLIN REXSON 150, avenue de Stalingrad 93 240 - STAINS - FRANCE Tél. 33 (0)1 49 40 25 25 - Fax : 33 (0)1 48 26 07 16
--	--

Déclare que le matériel désigné ci-après / Herewith declares that the equipment / erklårt hiermit, dass die / Declara que el material designado a continuación / Dichiaro che il materiale sottoindicato / Declara que o material a seguir designado / verklaart dat de hieronder aangeduide apparatuur / Kungör att den utrustning som anges här nedan / ilmoittaa, että alla mainitut laitteistot / Oświadcza, że wymienione poniżej urządzenia / Prohlašuje, že níže uvedené vybavení / Декларирует, что ниженазванное оборудование:

ENSEMBLE D'AGITATION / AGITATOR UNIT / RÜHRANLAGE / CONJUNTO DE AGITACIÓN
- CYCLIX II

POUR FUTS DE 40 LITRES / FOR 40 L / 10.6 US GAL DRUMS / FÜR 40 LITRE-FASS / PARA RECIPIENTES DE 40 LITROS
POUR FUTS DE 200 LITRES / FOR 200 L / 52.8 US GAL DRUMS / FÜR 200 LITER-FASS / PARA RECIPIENTES DE 200 LITROS

Est conforme à la législation d'harmonisation de l'Union applicable suivante / Is in conformity with the relevant Union harmonisation legislation / Erfüllt die einschlägigen Harmonisierungsrechtsvorschriften der Union / es conforme con la legislación de armonización pertinente de la Unión / è conforme alla pertinente normativa di armonizzazione dell'Unione / in overeenstemming met de desbetreffende harmonisatiewetgeving van de Unie / med den relevanta harmoniserade unionslagstiftningen / on asiaa koskevan unionin yhdenmukaistamislainsäädännön vaatimusten mukainen / jest zgodny z odpowiednimi wymaganiami unijnego prawodawstwa harmonizacyjnego / Shoduje se s následující příslušnou evropskou harmonizační legislativou / Соответствует следующим стандартизированным нормам Союза

Directive ATEX / ATEX Directive / ATEX Richtlinie / Directiva ATEX / Direttiva ATEX / Diretiva ATEX / ATEX-Richtlijn / ATEX-direktivet / ATEX-direktivi / Dyrektywa ATEX / Směrnice ATEX / Директива ATEX  II 2G c T5 EN 13463-5:2011 Protection par sécurité de construction "c" - Protection by constructional safety "c"	2014/34/UE
Procédure d'évaluation de la conformité : Module A Documentation technique (Annexe VIII) archivée par : / Conformity assessment procedure: Module A Technical documentation (ANNEX VIII) recorded by: / Verfahren zur Konformitätsbewertung: Modul A Technische Unterlagen (ANLAGE VIII) archiviert durch: / Procedimiento de evaluación de la conformidad: Módulo A Documentación técnica (ANEXO VIII) archivada por: / Procedura di valutazione della conformità: Modulo A Documentazione tecnica (ALLEGATO VIII) archiviata a cura di: / Procedimento de avaliação da conformidade: Módulo A Documentação técnica (ANEXO VIII) arquivada por: / Conformiteitsbeoordelingsprocedure: Module A Technische documentatie (BIJLAGE VIII) gearhiveerd door: / Förfarande för bedömning av överensstämmelse: Modul A Teknisk dokumentation (BILAGA VIII) arkiverad av: / Vaatimustenmukaisuusarviointimenetelmä: moduuli A Tekninen dokumentaatio (LIITE VIII) arkistoitu: / Procedura oceny zgodności: Moduł A Dokumentacji technicznej (ZAŁĄCZNIK VIII) zarchiwizowane przez: / Postup posuzování shody: Modul A Technická dokumentace (PŘÍLOHA VIII) archivována: / Процедура оценки соответствия: Модуль A Техническая документация (ПРИЛОЖЕНИЕ VIII), архивированная: ISSeP Zoning A. Schweitzer Rue de la Platinerie B - 7340 COLFONTAINE BELGIQUE	

Dominique LAGOUGE

Directeur Général / Chief Executive Officer / Generaldirektor
 / Director General / Direttore Generale / Director Geral / Algemeen
 Directeur / Generaldirektör / Pääjohtaja / Dyrektor Naczelny
 / Dyrektor Generalny / Generální ředitel / Генеральный директор

Fait à Stains, le / Established in Stains, on / Geschehen zu Stains, am / En Stains, a / Redatto a Stains, / Vastgesteld te Stains, / Utformat i Stains, den / Stains, Ranska, / Sporządzono w Stains, dnia / Stains, dnia / Издано в г. Стен (Stains) 08/04/2016 - 04/08/2016



<p align="center">FR</p> <p>Pour une utilisation sûre, il est de votre responsabilité de :</p> <ul style="list-style-type: none"> • Lire attentivement tous les documents contenus dans le CD joint avant la mise en service de l'équipement, • D'installer, d'utiliser, d'entretenir et de réparer l'équipement conformément aux préconisations de KREMLIN REXSON ainsi qu'aux réglementations nationales et/ou locales, • Vous assurez que les utilisateurs de cet équipement ont été formés, ont parfaitement compris les règles de sécurité et qu'ils les appliquent. 	<p align="center">UK</p> <p>To ensure safe use of the machinery, it is your responsibility to:</p> <ul style="list-style-type: none"> • Carefully read all documents contained on the enclosed CD before putting the machinery into service, • Install, use, maintain and repair the machinery in accordance with KREMLIN REXSON's recommendations and national and/or local regulations, • Make sure that the users of the machinery have received proper training and that they have perfectly understood the safety rules and apply them. 	<p align="center">DE</p> <p>Eine sichere Nutzung setzt voraus, dass Sie: :</p> <ul style="list-style-type: none"> • alle in der CD enthaltenen Dokumente vor der Inbetriebnahme der Anlage aufmerksam lesen, • die Anlage im Einklang mit den Empfehlungen von KREMLIN REXSON sowie mit den nationalen und/oder lokalen Bestimmungen installieren, verwenden, warten und reparieren, • sich vergewissern, dass die Nutzer dieser Anlage angemessen geschult wurden, die Sicherheitsbestimmungen verstanden haben und sie anwenden.
<p align="center">ES</p> <p>Para una utilización segura, será de su responsabilidad:</p> <ul style="list-style-type: none"> • leer atentamente todos los documentos que se incluyen en el CD adjunto antes de la puesta en servicio del equipo, • instalar, utilizar, efectuar el mantenimiento y reparar el equipo con arreglo a las recomendaciones de KREMLIN REXSON y a la normativa nacional y/o local, • cerciorarse de que los usuarios de este equipo han recibido la formación necesaria, han entendido perfectamente las normas de seguridad y las aplican. 	<p align="center">IT</p> <p>Per un uso sicuro, vi invitiamo a:</p> <ul style="list-style-type: none"> • leggere attentamente tutta la documentazione contenuta nel CD allegato prima della messa in funzione dell'apparecchio, • installare, utilizzare, mantenere e riparare l'apparecchio rispettando le raccomandazioni di KREMLIN REXSON, nonché le normative nazionali e/o locali, • accertarvi che gli utilizzatori dell'apparecchio abbiano ricevuto adeguata formazione, abbiano perfettamente compreso le regole di sicurezza e le applichino. 	<p align="center">PT</p> <p>Para uma utilização segura, é da sua responsabilidade:</p> <ul style="list-style-type: none"> • Ler atentamente todos os documentos incluídos no CD em anexo antes de pôr o equipamento em funcionamento, • Proceder à instalação, utilização, manutenção e reparação do equipamento de acordo com as preconizações de KREMLIN REXSON, bem como com outros regulamentos nacionais e/ou locais aplicáveis, • Assegurar-se que os utilizadores do equipamento foram devidamente capacitados, compreenderam perfeitamente e aplicam as devidas regras de segurança.
<p align="center">NL</p> <p>Voor een veilig gebruik dient u:</p> <ul style="list-style-type: none"> • alle document op de bijgevoegde cd aandachtig te lezen alvorens het apparaat in werking te stellen, • het apparaat te installeren, gebruiken, onderhouden en repareren volgens de door KREMLIN REXSON gegeven aanbevelingen en overeenkomstig de nationale en/of plaatselijke reglementeringen, • zeker te stellen dat de gebruikers van dit apparaat zijn opgeleid, de veiligheidsregels perfect hebben begrepen en dat zij die ook toepassen. 	<p align="center">SE</p> <p>För en säker användning av utrustningen ansvarar ni för följande:</p> <ul style="list-style-type: none"> • Läs noga samtliga dokument som finns på den medföljande cd-skivan innan utrustningen tas i drift. • Installera, använd, underhåll och reparera utrustningen enligt anvisningarna från KREMLIN REXSON och enligt nationella och/eller lokala bestämmelser. • Försäkra er om att användare av denna utrustning erhållit utbildning, till fullo förstått säkerhetsföreskrifterna och tillämpar dem. 	<p align="center">FI</p> <p>Käytön turvallisuuden varmistamiseksi velvollisuutesi on:</p> <ul style="list-style-type: none"> • Lukea huolella kaikki CD:llä olevat asiakirjat ennen laitteiston käyttöönottoa, • Noudattaa laitteiston asennuksessa, käytössä, kunnossapidossa ja huollossa KREMLIN REXSON in suosituksia sekä kansallisia ja/tai paikallisia määräyksiä, • Varmistaa, että laitteiston käyttäjät ovat koulutettuja ja ymmärtävät täysin turvallisuusmääräykset ja miten niitä sovelletaan.
<p align="center">PL</p> <p>Dla zapewnienia bezpiecznego użytkowania na użytkownika spoczywa obowiązek:</p> <ul style="list-style-type: none"> • Uważnego zapoznania się ze wszystkimi dokumentami znajdującymi się na załączonej płycie CD przed pierwszym uruchomieniem urządzenia, • Instalowania, użytkowania, konserwacji i naprawy urządzenia zgodnie z zaleceniami firmy KREMLIN REXSON oraz z przepisami miejscowymi, • Upewnienia, że wszyscy przeszkoleni użytkownicy urządzenia zrozumieli zasady bezpieczeństwa i stosują się do nich. 	<p align="center">CS</p> <p>Pro bezpečné používání jste povinni:</p> <ul style="list-style-type: none"> • Před uvedením zařízení do provozu si pozorně přečíst veškeré dokumenty obsažené na příloženém CD, • Nainstalovat, používat, udržovat a opravovat zařízení v souladu s pokyny firmy KREMLIN REXSON a s národními a/nebo místními legislativními předpisy, • Ujistit se, že uživatelé tohoto zařízení byli vyškoleni, že dokonale pochopili bezpečnostní pravidla a že je dodržují. 	<p align="center">RU</p> <p>Для целей безопасного использования необходимо:</p> <ul style="list-style-type: none"> • Ознакомиться со всеми документами, содержащимися в прилагаемом компакт-диске до ввода оборудования в эксплуатацию; • Устанавливать, использовать, производить техническое обслуживание и ремонт оборудования в соответствии с рекомендациями KREMLIN REXSON и национальным и/или местным законодательством; • Убедиться, что пользователи настоящего оборудования прошли подготовку, надлежащим образом усвоили правила безопасности и обеспечивают их соблюдение.

Déclaration(s) de conformité au verso de ce document / Declaration(s) of conformity at the back of this document / Konformitätserklärung(en) auf der Rückseite dieser Unterlage / Declaración (es) de conformidad en el reverso de este documento / Dichiarazione/i di conformità sul retro del presente documento / Declaração(ões) de conformidade no verso do documento / Conformiteitsverklaring(en) op de keerzijde van dit document / Försäkran om överensstämmelse på omstående sida av detta dokument / Vaatimustenmukaisuusvakuutukset tämän asiakirjan kääntöpuolella / Deklaracja(e) zgodności na odwrocie dokumentu / Prohlášení o shodě se nachází/nacházejí na zadní straně tohoto dokumentu / Сертификат(ы) соответствия расположены на оборотной стороне настоящего документа

VALABLE JUSQU'AU 19 AVRIL 2016
VALID UNTIL 19 APRIL 2016
GÜLTIG BIS ZUM 19. APRIL 2016
VALIDEZ HASTA EL 19 DE ABRIL DE 2016
VALIDO FINO AL 19 APRILE 2016
APLICÁVEL ATÉ 19 DE ABRIL DE 2016
GELDIG TOT 19 APRIL 2016
GÄLLER TILL OCH MED DEN 19 APRIL 2016
VOIMASSA 19.4.2016 SAAKKA
WAŻNOŚĆ DO 19 KWIETNIA 2016 R.
PLATÍ DO 19. DUBNA 2016
ДЕЙСТВИТЕЛЬНО ДО 19 АПРЕЛЯ 2016 ГОДА



DECLARATION CE DE CONFORMITE
EC DECLARATION OF CONFORMITY
EG KONFORMITÄTSERKLÄRUNG
DECLARACIÓN CE DE CONFORMIDAD
DICHIARAZIONE CE DI CONFORMITÀ
DECLARAÇÃO CE DE CONFORMIDADE
EG-VERKLARING VAN OVEREENSTEMMING
EG-FÖRSÄKRAN OM ÖVERENSSTÄMMESE
EY-VAATIMUKSEN MUKAISUUSVAKUUTUS
DEKLARACJA ZGODNOŚCI CE
CE PROHLÁŠENÍ O SHODĚ
ДЕКЛАРАЦИЯ СООТВЕТСТВИЯ CE

Le fabricant / The manufacturer / Der Hersteller / El fabricante / Il produttore / O fabricante / De fabrikant / Tillverkare / Valmistaja / Producent / Výrobce / Изготовитель:	KREMLIN REXSON 150, avenue de Stalingrad 93 240 - STAINS - FRANCE Tél. 33 (0)1 49 40 25 25 - Fax : 33 (0)1 48 26 07 16
--	--

Déclare que le matériel désigné ci-après / Herewith declares that the equipment / erklärt hiermit, dass die / Declara que el material designado a continuación / Dichiaro che il materiale sottoindicato / Declara que o material a seguir designado / verklaart dat de hieronder aangeduide apparatuur / Kungör att den utrustning som anges här nedan / ilmoittaa, että alla mainitut laitteistot / Oświadczka, że wymienione poniżej urządzenia / Prohlašuje, že níže uvedené vybavení / Декларирует, что ниженазванное оборудование:

ELEVATEUR / SINGLE-POST RAM / PUMPENLIFT / ELEVADOR
- CYCLIX II

POUR FUTS DE 40 LITRES / FOR 40 L / 10.6 US GAL DRUMS / FÜR 40 LITRE-FASS / PARA RECIPIENTES DE 40 LITROS
POUR FUTS DE 200 LITRES / FOR 200 L / 52.8 US GAL DRUMS / FÜR 200 LITER-FASS / PARA RECIPIENTES DE 200 LITROS

Est conforme à la législation d'harmonisation de l'Union applicable suivante / Is in conformity with the relevant Union harmonisation legislation / Erfüllt die einschlägigen Harmonisierungsrechtsvorschriften der Union / es conforme con la legislación de armonización pertinente de la Unión / è conforme alla pertinente normativa di armonizzazione dell'Unione / in overeenstemming met de desbetreffende harmonisatiewetgeving van de Unie / med den relevanta harmoniserade unionslagstiftningen / on asiaa koskevan unionin yhdenmukaistamislainsäädännön vaatimusten mukainen / jest zgodny z odpowiednimi wymaganiami unijnego prawodawstwa harmonizacyjnego / Shoduje se s následující příslušnou evropskou harmonizační legislativou / Соответствует следующим стандартизированным нормам Союза

Directive ATEX / ATEX Directive / ATEX Richtlinie / Directiva ATEX / Direttiva ATEX / Diretiva ATEX / ATEX-Richtlijn / ATEX-direktivet / ATEX-direktivi / Dyrektywa ATEX / Směrnice ATEX / Директива ATEX  EN 13463-5:2011 Protection par sécurité de construction "c" - Protection by constructional safety "c"	94/9/CE
--	----------------

Dominique LAGOUGE

Directeur Général / Chief Executive Officer / Generaldirektor
 / Director General / Direttore Generale / Director Geral / Algemeen
 Directeur / Generaldirektör / Pääjohtaja / Dyrektor Naczelny
 / Dyrektor Generalny / Generální ředitel / Генеральный директор

Fait à Stains, le / Established in Stains, on / Geschehen zu Stains, am / En Stains, a / Redatto a Stains, / Vastgesteld te Stains, / Utformat i Stains, den / Stains, Ranska, / Sporządzono w Stains, dnia / Stains, dnia / Издано в г. Стен (Stains) 04/09/2014 - 04/09/2014

VALABLE A PARTIR DU 20 AVRIL 2016
VALID FROM 20 APRIL 2016
GÜLTIG AB DEM 20. APRIL 2016
VALIDEZ A PARTIR DEL 20 DE ABRIL DE 2016
VALIDO A PARTIRE DAL 20 APRILE 2016
APLICÁVEL A PARTIR DE 20 DE ABRIL DE 2016
GELDIG VANAF 20 APRIL 2016.
GÄLLER FRÅN OCH MED DEN 20 APRIL 2016
VOIMASSA 20.4.2016 ALKAEN
WAŻNOŚĆ OD 20 KWIETNIA 2016 R.
PLATÍ OD 20. DUBNA 2016
ДЕЙСТВИТЕЛЬНО С 20 АПРЕЛЯ 2016 ГОДА



DECLARATION UE DE CONFORMITE
UE DECLARATION OF CONFORMITY
EU-KONFORMITÄTSEKTLÄRUNG
DECLARACIÓN UE DE CONFORMIDAD
DICHIARAZIONE DI CONFORMITÀ UE
DECLARAÇÃO UE DE CONFORMIDADE
EU-CONFORMITEITSVERKLARING
EU-FÖRSÄKRAN OM ÖVERENSSTÄMMELSE
EU-VAATIMUKSEN MUKAISUUSVAKUUTUS
DEKLARACJA ZGODNOŚCI UE
EU PROHLÁŠENÍ O SHODĚ
ДЕКЛАРАЦИЯ О СООТВЕТСТВИИ НОРМАМ ЕС

Le fabricant / The manufacturer / Der Hersteller / El fabricante / Il produttore / O fabricante / De fabrikant / Tillverkare / Valmistaja / Producent / Výrobce / Изготовитель:	KREMLIN REXSON 150, avenue de Stalingrad 93 240 - STAINS - FRANCE Tél. 33 (0)1 49 40 25 25 - Fax : 33 (0)1 48 26 07 16
--	--

Déclare que le matériel désigné ci-après / Herewith declares that the equipment / erklårt hiermit, dass die / Declara que el material designado a continuación / Dichiaro che il materiale sottoindicato / Declara que o material a seguir designado / verklaart dat de hieronder aangeduide apparatuur / Kungör att den utrustning som anges här nedan / ilmoittaa, että alla mainitut laitteistot / Oświadcza, że wymienione poniżej urządzenia / Prohlašuje, že níže uvedené vybavení / Декларирует, что ниженазванное оборудование:

ELEVATEUR / SINGLE-POST RAM / PUMPENLIFT / ELEVADOR
- CYCLIX II

POUR FUTS DE 40 LITRES / FOR 40 L / 10.6 US GAL DRUMS / FÜR 40 LITRE-FASS / PARA RECIPIENTES DE 40 LITROS
POUR FUTS DE 200 LITRES / FOR 200 L / 52.8 US GAL DRUMS / FÜR 200 LITER-FASS / PARA RECIPIENTES DE 200 LITROS

Est conforme à la législation d'harmonisation de l'Union applicable suivante / Is in conformity with the relevant Union harmonisation legislation / Erfüllt die einschlägigen Harmonisierungsrechtsvorschriften der Union / es conforme con la legislación de armonización pertinente de la Unión / è conforme alla pertinente normativa di armonizzazione dell'Unione / in overeenstemming met de desbetreffende harmonisatiewetgeving van de Unie / med den relevanta harmoniserade unionslagstiftningen / on asiaa koskevan unionin yhdenmukaistamislainsäädännön vaatimusten mukainen / jest zgodny z odpowiednimi wymaganiami unijnego prawodawstwa harmonizacyjnego / Shoduje se s následující příslušnou evropskou harmonizační legislativou / Соответствует следующим стандартизированным нормам Союза

Directive ATEX / ATEX Directive / ATEX Richtlinie / Directiva ATEX / Direttiva ATEX / Diretiva ATEX / ATEX-Richtlijn / ATEX-direktivet / ATEX-direktivi / Dyrektywa ATEX / Směrnice ATEX / Директива ATEX EN 13463-5:2011 Protection par sécurité de construction "c" - Protection by constructional safety "c"	2014/34/UE
Procédure d'évaluation de la conformité : Module A Documentation technique (Annexe VIII) archivée par : / Conformity assessment procedure: Module A Technical documentation (ANNEX VIII) recorded by: / Verfahren zur Konformitätsbewertung: Modul A Technische Unterlagen (ANLAGE VIII) archiviert durch: / Procedimiento de evaluación de la conformidad: Módulo A Documentación técnica (ANEXO VIII) archivada por: / Procedura di valutazione della conformità: Modulo A Documentazione tecnica (ALLEGATO VIII) archiviata a cura di: / Procedimento de avaliação da conformidade: Módulo A Documentação técnica (ANEXO VIII) arquivada por: / Conformiteitsbeoordelingsprocedure: Module A Technische documentatie (BIJLAGE VIII) gearhiveerd door: / Förfarande för bedömning av överensstämmelse: Modul A Teknisk dokumentation (BILAGA VIII) arkiverad av: / Vaatimusten mukaisuusarviointimenetelmä: moduuli A Tekninen dokumentaatio (LIITE VIII) arkistoitu: / Procedura oceny zgodności: Moduł A Dokumentacji technicznej (ZAŁĄCZNIK VIII) zarchiwizowane przez: / Postup posuzování shody: Modul A Technická dokumentace (PŘÍLOHA VIII) archivována: / Процедура оценки соответствия: Модуль A Техническая документация (ПРИЛОЖЕНИЕ VIII), архивированная: ISSeP Zoning A. Schweitzer Rue de la Platinerie B - 7340 COLFONTAINE BELGIQUE	

Dominique LAGOUGE

Directeur Général / Chief Executive Officer / Generaldirektor
 / Director General / Direttore Generale / Director Geral / Algemeen
 Directeur / Generaldirektör / Pääjohtaja / Dyrektor Naczelny
 / Dyrektor Generalny / Generální ředitel / Генеральный директор

Fait à Stains, le / Established in Stains, on / Geschehen zu Stains, am / En Stains, a / Redatto a Stains, / Vastgesteld te Stains, / Utformat i Stains, den / Stains, Ranska, / Sporządzono w Stains, dnia / Stains, dnia / Издано в г. Стен (Stains) 08/04/2016 - 04/08/2016



INSTALLATION AND SAFETY INSTRUCTIONS

TRANSLATION OF THE ORIGINAL MANUAL

IMPORTANT : Before assembly and start-up, please read and clearly understand all the documents relating to this equipment (professional use only).

THE PICTURES AND DRAWINGS ARE NON CONTRACTUAL. WE RESERVE THE RIGHT TO MAKE CHANGES WITHOUT PRIOR NOTICE.

KREMLIN - REXSON

150, avenue de Stalingrad

93 245 - STAINS CEDEX – France

☎ : 33 (0)1 49 40 25 25 *Fax* : 33 (0)1 48 26 07 16

www.kremlin-rexson.com

1. SAFETY INSTRUCTIONS

GENERAL SAFETY INSTRUCTIONS



CAUTION : The equipment can be dangerous if you do not follow our instructions concerning installation and servicing described in this manual and in accordance with applicable European standards and local national safety regulations.

Please carefully read all the instruction literature before operating your equipment.

Only trained operators can use the equipment (To acquire an essential training, please contact the "KREMLIN REXSON University" training center - Stains).

The foreman must ensure that the operator has understood the safety instructions for this equipment as well as the instructions in the manuals for the different parts and accessories.

Read carefully all instruction manuals, label markings before operating the equipment.



















Incorrect use may result in injury. This equipment is for professional use only. It must be used only for what it has been designed for. Never modify the equipment. The parts and accessories supplied must be regularly inspected. Defective or worn parts must be replaced.

Guards (motor cover, coupling shields, connectors,...) have been designed for a safe use of the equipment.
The manufacturer will not be held responsible for bodily injury or failure and / or property damage due to destruction, the overshadowing or the partial or total removal of the guards.

Never exceed the equipment components' maximum working pressure.

Comply with regulations concerning safety, fire risks, electrical regulations in force in the country of final destination of the material. Use only products or solvent compatible with the parts in contact with the material (refer to data sheet of the material manufacturer).

PICTOGRAMS

					
NIP HAZARD	WARNING MOVING ELEVATOR	WARNING MOVING PARTS	WARNING MOVING SHOVEL	DO NOT EXCEED THIS PRESSURE	HIGH PRESSURE HAZARD
					
RELIEF OR DRAIN VALVE	WARNING HOSE UNDER PRESSURE	WEAR GLASSES OBLIGATORY	WEAR OF GLOVES IS OBLIGATORY	PRODUCT VAPOR HAZARDS	WARNING HOT PARTS OR AREAS
					
ELECTRICAL HAZARD	WARNING FIRE HAZARDS	EXPLOSION HAZARDS	GROUNDING	WARNING (USER)	WARNING SERIOUS INJURIES

FIRE - EXPLOSION - SPARKS - STATIC ELECTRICITY HAZARDS

A poor earth connection, inadequate ventilation, sparks or static electricity can cause an explosion or fire. to avoid these risks when using or servicing KREMLIN REXSON equipment, the following safety procedures must be followed :



- ensure a good earth connection and ground the parts to be handled i.e. solvents, materials, components and equipment,
- ensure adequate ventilation,
- keep working area clean and free from waste solvents, chemicals, or solid waste i.e. rags, paper and empty chemicals drums,
- never use electrical switches / power if in an atmosphere of volatile solvent vapour,
- stop working immediately in case of electrical arcs,
- never store chemicals and solvents in the working area.
- use paint whose flash point is the highest possible to prevent from any formation of gas and inflammable vapours (refer to materials' safety instructions),
- install a cover on the drums to reduce the diffusion of gas and vapours in the spraybooth.

TOXIC PRODUCT HAZARDS

Toxic products or vapours can cause severe injury not only through contact with the body, but also if the products are ingested or inhaled. It is imperative :



- to know the material products and their risks,
- notified or hazardous materials must be stored in accordance with the regulations,
- the material must be stored in an appropriate container, never place materials in a container where there is a risk of spillage or leakage,
- a procedure must be applied for the safe disposal of waste material. It must comply with all prevailing regulations and legislations of the country where the equipment is to be used,
- protective clothing should always be worn in compliance with the material manufacturers' recommendations,
- depending on the application and chemical safety instructions, safety glasses, hearing protective earplug, gloves, foot wear, protective masks and possible breathing equipment should be worn to comply with the regulations (Refer to chapter "Safety equipment of KREMLIN selection guide).



CAUTION!



It is forbidden to use material containing high concentrations of halogenated hydrocarbon solvents with **aluminium or zinc fillers** .Non-compliance with the instructions may cause explosion risk causing serious or fatal injury.

EQUIPMENT REQUIREMENTS

Guards (motor cover, coupling shields, connectors,...) have been designed for a safe use of the equipment.

The manufacturer will not be held responsible for bodily injury or failure and / or property damage due to destruction, the overshadowing or the partial or total removal of the guards.

PUMP



Before carrying out any work, it is imperative to read and clearly understand the disassembly and reassembly instructions before servicing. The operator must understand the equipment and the safety instructions. These instructions are available in the equipment manuals.



The air motor is designed to be mounted with a pump. Never modify any components or couplings. When operating, please keep hands away from moving parts. Before starting up the equipment, please read the PRESSURE RELIEF instructions. Please ensure that any relief or drain valves fitted are in good working order.

HOSES

- Keep hoses out of circulation areas, moving parts or hot surfaces,
- Never expose product hoses to temperature higher than + 60°C / 140° F or lower than 0°C / 32° F,
- Never pull or use the hoses to move the equipment,
- Tighten all fittings as well as the hoses before operating the equipment,
- Check the hoses regularly; change them if they are damaged,
- Never exceed the working pressure (WP) indicated on the hose.

USED PRODUCTS

Considering the wide variety of products that are available and can be used in our equipment it is impossible to check and make recommendations for all chemical data, regarding the risks of possible chemical attack and their long term chemical reaction

KREMLIN REXSON can not be held liable for :

- Compatibility of wetted parts,
- Risks to staff and the surroundings,
- for worn or defective parts, for faulty equipment or units, or the quality of final product.

It is the responsibility of the user to know and prevent any possible risks such as toxic vapours, fires or explosions. He shall determine the risks of immediate reactions or pursuant to repeated exposures of the staff,

KREMLIN REXSON shall not be liable for physical injuries, direct or indirect material damages caused by the use of chemicals.

2. HANDLING



Check the weight and the dimensions of the equipment

(☞ refer to 'Technical features' section of the instruction manual

If weight and dimensions are too important, the unloading must be carried out by means of a forklift or any other appropriate means with a qualified personnel and in a clear horizontal area to prevent from risks of damage injury or an accident.

The centre of gravity is not in the centre of the machine : carry out by hand a stability-test after having lifted the whole at 10 cm / 3.937" maximum.

After the unloading, the handling of the whole (eg: elevator pump) is carried out by means of a pallet truck taking the bottom part of the frame.

Remark : Each pump motor is fitted with a ring. The ring is designed for the hoisting of one pump and can not be used for the handling of the complete machine.

3. STORING

Storing before installation :

- Storing ambient temperature : 0 / +50 °C / 0 / +122°F
- Protect the whole against dust, water trickling, dampness and shocks.

Storing after installation :

- Operating temperature : +15 / +35 °C / +59 / +138.2° F
- Protect the whole against dust, water trickling, dampness and shocks.

4. INSTALLATION OF THE EQUIPMENT

The machine is installed on a stable horizontal floor (for eg a concrete flag).



To avoid risks caused by static electricity, the equipment as well as its components must be grounded.

- **For the pumping equipments** (pumps, pneumatic rams, frame...), a section wire of 2.5 mm² is fixed on the material. Use this wire to connect the material to "the general ground". In case of severe environments (mechanical protection of the wire of earthing insufficient, vibrations, mobile material...) where function damages at the ground are probable, the user have to replace the provided wire of 2.5 mm² by a device more adapted to its environment (wire with a more important section, bonding strip, fixing by thimble with eyelet...),

The continuity of the ground must be controlled by a qualified electrician. If the continuity of the ground is not ensured, check the terminal, the wire and the earthing point. **Never** use the material without have solved this problem.

- In the severe cases of environments (mechanical protection of the wire of earthing insufficient, vibrations, mobile material...) where damages of the function put at the ground are probable, the user will have to replace the wire of 2.5 mm² provided, by a device more adapted to its environment (wire of more important section, bonding strip, fixing by thimble with eyelet...),
- **The gun** must be 'grounded' via a material hose or an air hose. In case of spraying by means of a gun with cup, the air hose must be conductive,
- **The materials to be painted** must also be grounded.

All the materials situated in the working area shall be grounded.



- **Never store** more than necessary inflammable materials inside the working area,
- The materials must be stored into **approved drums** and grounded,
- Use only grounded **metals containers** for the use of cleaning solvents,
- **Cardboard and paper are prohibited.**

5. MARKING OF THE EQUIPMENT

Each equipment has a marking plate.

The plate consists of the name of the manufacturer, the equipment part number and important information for correct use of the equipment (air pressure, electric power,...).

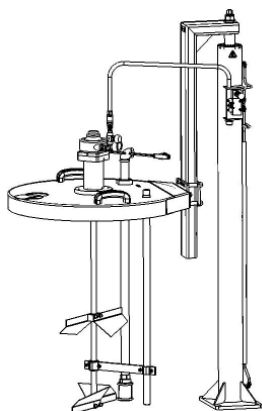
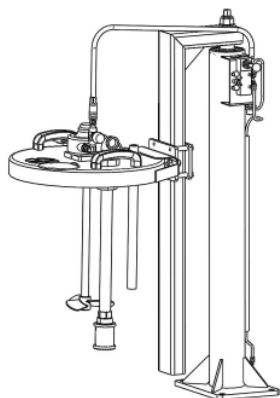

**AGITATION UNIT
40 L / 10.6 US gal
&
200 L / 52.8 US gal
CYCLIX II**

Specific safety instructions

TRANSLATION FROM THE ORIGINAL MANUAL

IMPORTANT : Before assembly and start-up, please read and clearly understand all the documents relating to this equipment (professional use only).

THE PICTURES AND DRAWINGS ARE NON CONTRACTUAL. WE RESERVE THE RIGHT TO MAKE CHANGES WITHOUT PRIOR NOTICE.

KREMLIN - REXSON

150, avenue de Stalingrad

93 245 - STAINS CEDEX - France

☎ : 33 (0)1 49 40 25 25 **Fax** : 33 (0)1 48 26 07 16

www.kremlin-rexson.com

Before operating the equipment, please ensure that the operators have been trained to use the equipment correctly.



The foreman must ensure that the operators have understood the safety instructions of this equipment as well as the instructions in the manuals for the different parts and accessories (refer to agitator instruction manual).

Any improper installation can lead the operator to dangerous conditions.



The operator must wear the appropriate clothing (protective masks, gloves, glasses...) depending on the use of the equipment.



The working area must be correctly ventilated.

Keep away from moving parts. Do not stay in front of the exhaust.

Do not supply the equipment with air pressures other than the ones recommended. Damage can occur if you use the equipment with speeds other than the ones recommended.

Nota : You must lubricate the motor of the agitator. Dirt due to oil can be present on the cover. To avoid this, mount a grease recovery assembly to the motor exhaust (see Doc. 'Sparts parts' - option).

Do not modify the hoses.

Guards (air motor cover, coupling shields, housings ...) have been designed for safe use of the equipment.

The manufacturer will not be held responsible for bodily injury or failure and / or damage to property due to removal or partial removal of the guards



Keep away hands and fingers from the blades of the agitator. Do not operate the blades out of the drum. Serious injuries can occur (cuts).



Keep a sufficient gap between the bottom of the drum and the blades of the agitator to avoid frictions and sparks.



Please ensure that the air motor is mounted in the correct orientation to avoid any damage.

Agitation unit - 40 Liters

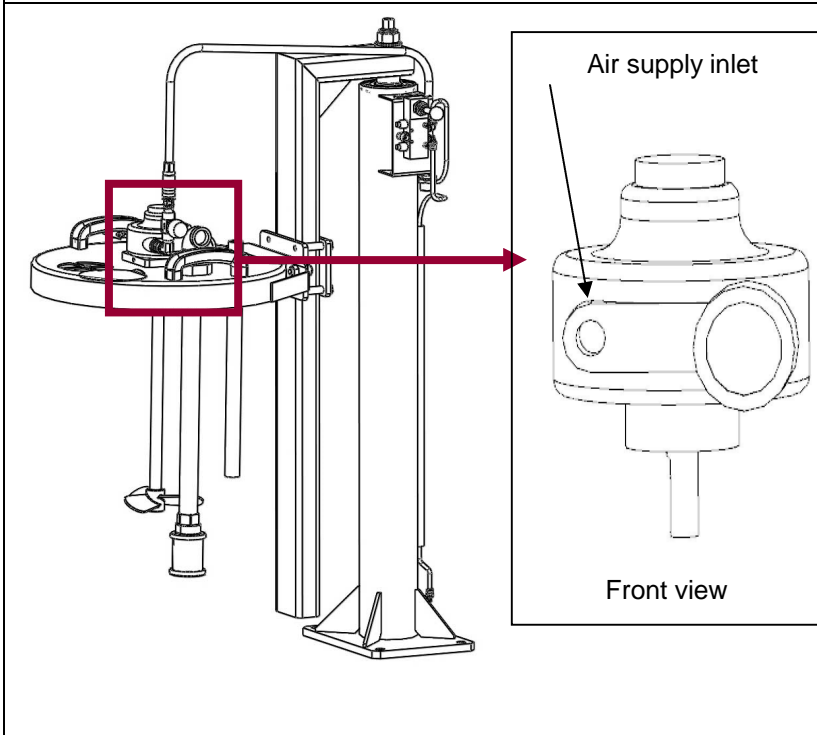

Rotating direction of the motor
→ clockwise rotation.

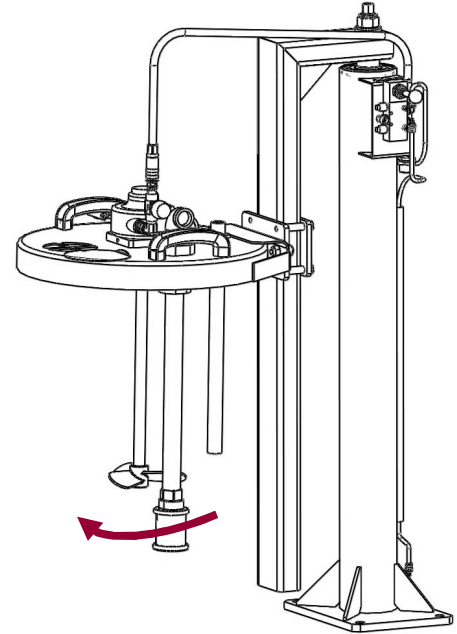

Agitation unit - 200 Liters

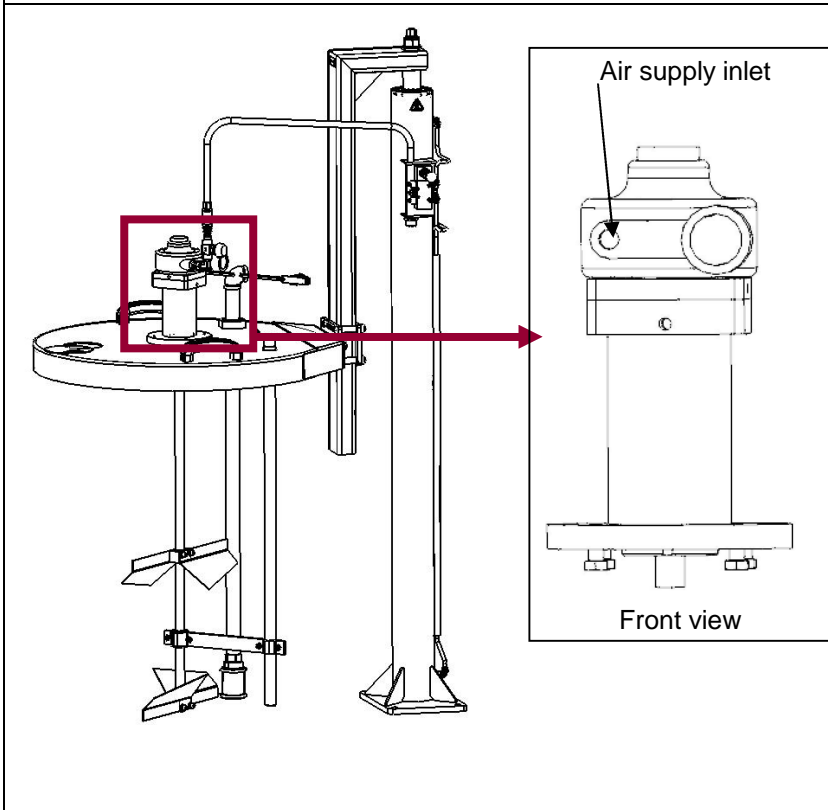

Rotating direction of the motor
→ clockwise rotation.

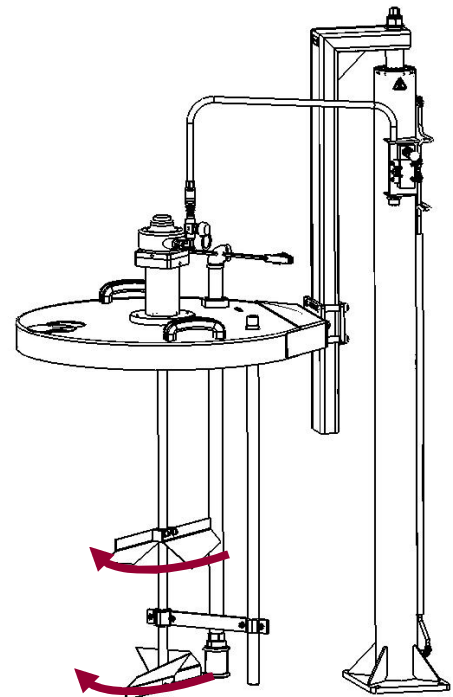

**UNITE D'AGITATION / AGITATION UNIT
RÜHRWERKE / UNIDAD DE AGITACIÓN
40 L / 10.6 US GAL
CYCLIX II**

**NOTICE ORIGINALE
/ TRANSLATION FROM THE ORIGINAL MANUAL
/ ÜBERSETZUNG DER ORIGINAL BETRIEBSANLEITUNG
/ TRADUCCIÓN DEL LIBRO ORIGINAL**

**L'équipement est soumis à la directive ATEX et ne doit en aucun cas être modifié. Le non-respect de cette préconisation ne saurait engager notre responsabilité.
/ The equipment is manufactured under the ATEX agreement and should not be modified. KREMLIN REXSON will not be held responsible for any failure to comply with that instruction.**

/ Diese Anlage hat die ATEX Zulassung, deswegen darf sie nie verändert werden. Bei Nichtbeachtung dieser Anordnung, können wir keine Verantwortung für eine einwandfreie, regelkonforme Funktion der Anlage übernehmen.

/ El equipo es de conformidad a la directiva ATEX y no debe ser modificada, en ningún caso. KREMLIN REXSON no se hace responsable de que esta preconización no sea respetada.

Des protecteurs (capot moteur, protecteur d'accouplement, carters,...) sont mis en place pour une utilisation sûre du matériel.

Le fabricant ne peut être tenu pour responsable en cas de dommages corporels ainsi que des pannes et / ou endommagement du matériel résultant de la destruction, de l'occultation ou du retrait total ou partiel des protecteurs.

/ Guards (motor cover, coupling shields, connectors,...) have been designed for a safe use of the equipment. The manufacturer will not be held responsible for bodily injury or failure and / or property damage due to destruction, the overshadowing or the partial or total removal of the guards

/ Schutzvorrichtungen an diesem Gerät, wie Motorhaube, Kupplungsschutz, Gehäuse, ggf. Erdungskabel, sowie weitere Vorrichtungen, wurden für eine sichere Benutzung dieses Gerätes entwickelt und angebracht. Der Hersteller lehnt jede Verantwortung für Körperschäden, Fehlfunktionen, Beschädigung der Geräte, und jegliche andere Fehler ab, die durch die ganze oder teilweise Entfernung, Modifikation oder unsachgemäße Handhabung der Schutzvorrichtungen oder anderen Geräteteilen entstehen.

/ Protectores (capó motor, protector de acoplamiento, cárteres,...) se colocan para una utilización segura del material. El fabricante no se hace responsable, en caso de daños personales, así como de las averías y / o daños del material, resultantes de la destrucción, la ocultación o la retirada total o parcial de los protectores.

Vous aurez besoin de / you need / Werkzeugaufstellung / Vd necesita :

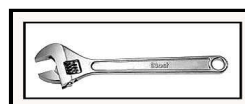
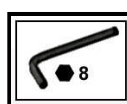

1

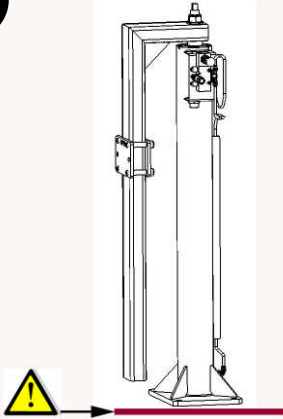

L'élévateur est installé sur un sol horizontal, stable et plan (ex : dalle de béton). Il doit être fixé au sol par des dispositifs de fixation adaptés (spit, vis, boulons,...) permettant d'assurer leur stabilité pendant leur utilisation.
The post-ram shall be made stable by the use of anchoring devices (screws, bolts,...) needed to achieve the stability.
Der Hubzylinder muss zur besseren Standfestigkeit, mit Schrauben und Dübel am Boden fixiert werden.
 El elevador está instalado en un suelo horizontal, estable y plano (ej : badosa de hormigón). Debe ser fijado al suelo mediante elementos de sujeción (anclaje mecánicos o químicos tipo Spit) adecuados para asegurar la estabilidad del conjunto durante el uso.

2

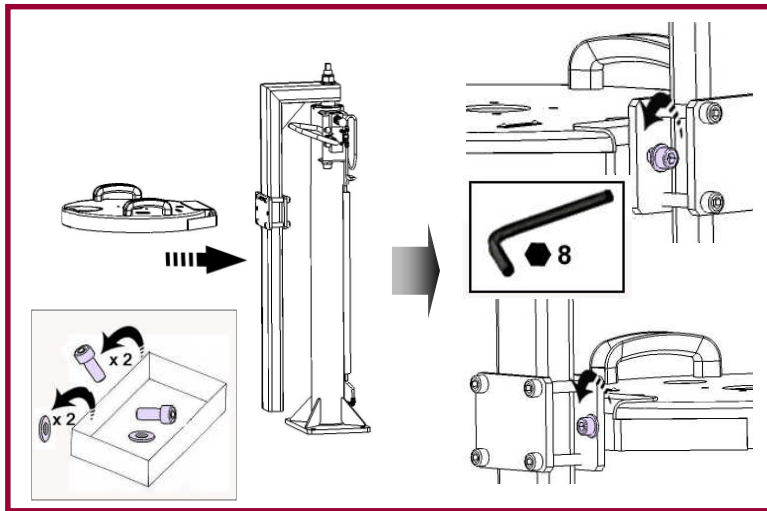

4

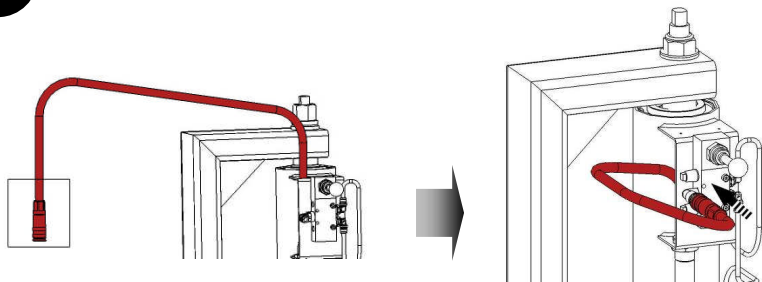

3



5

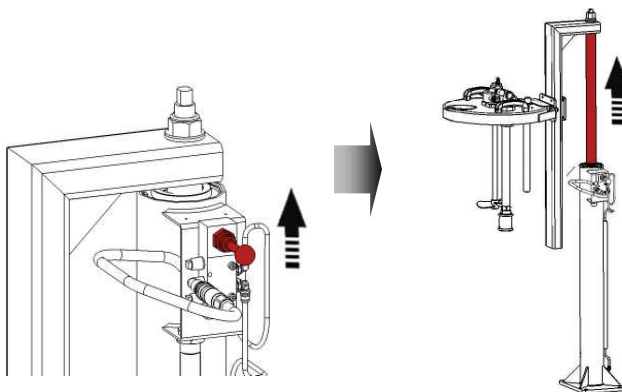

6

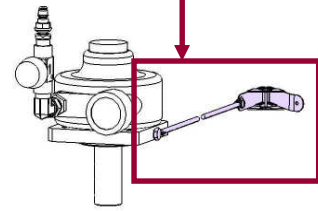
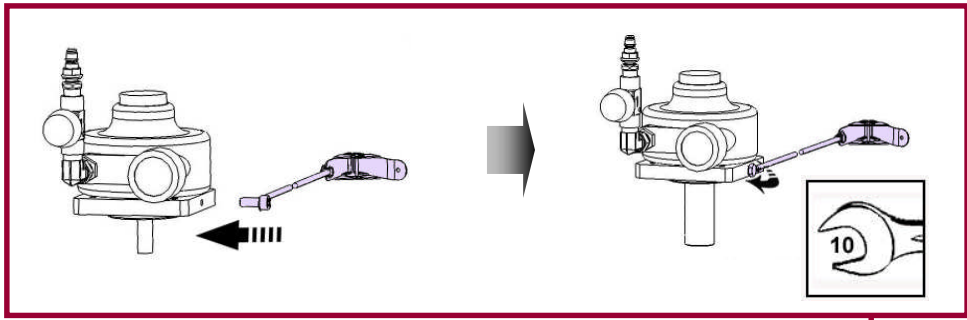

7

1

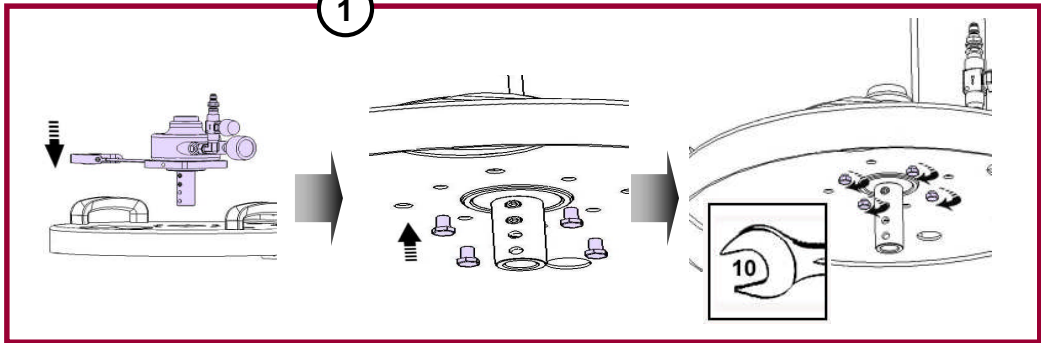

2

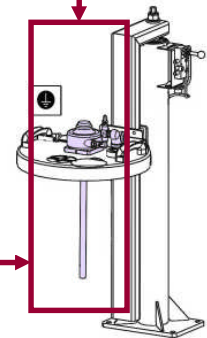
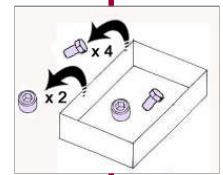
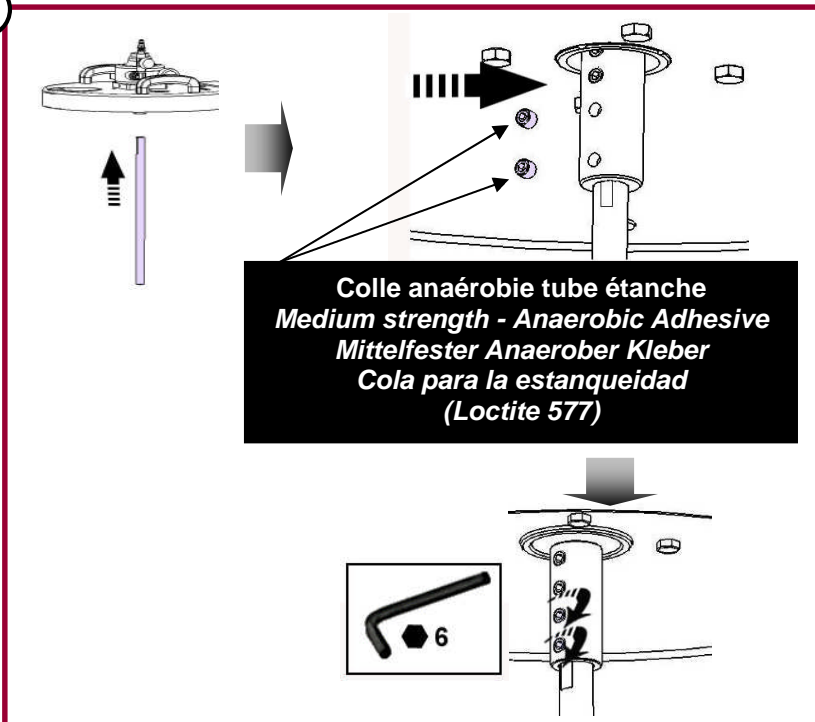

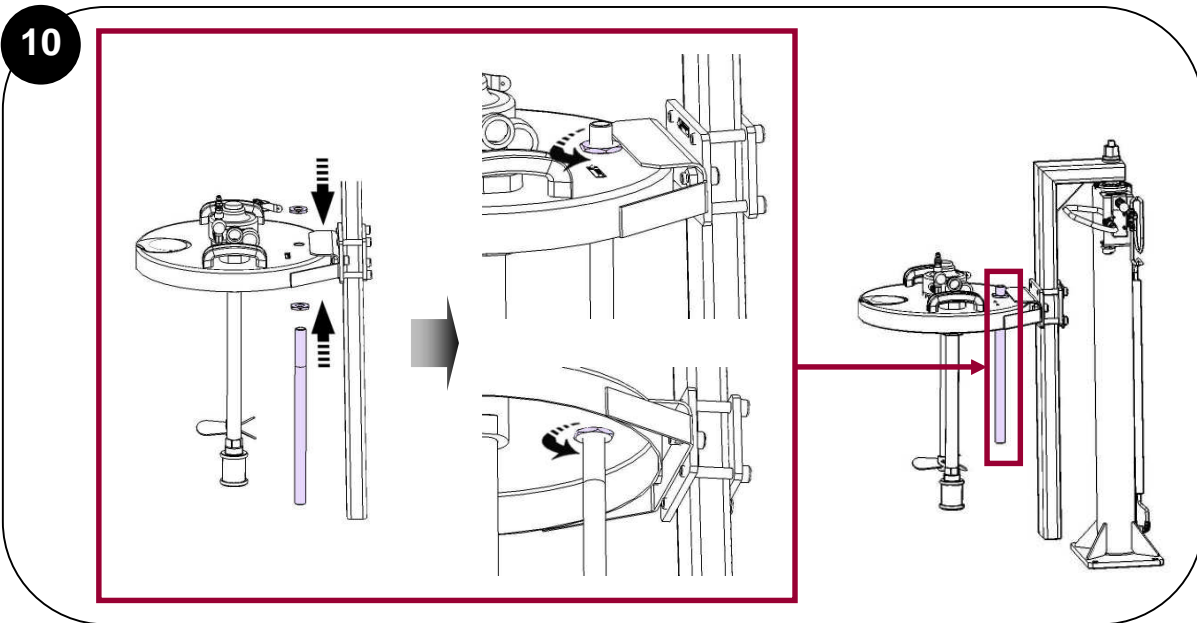
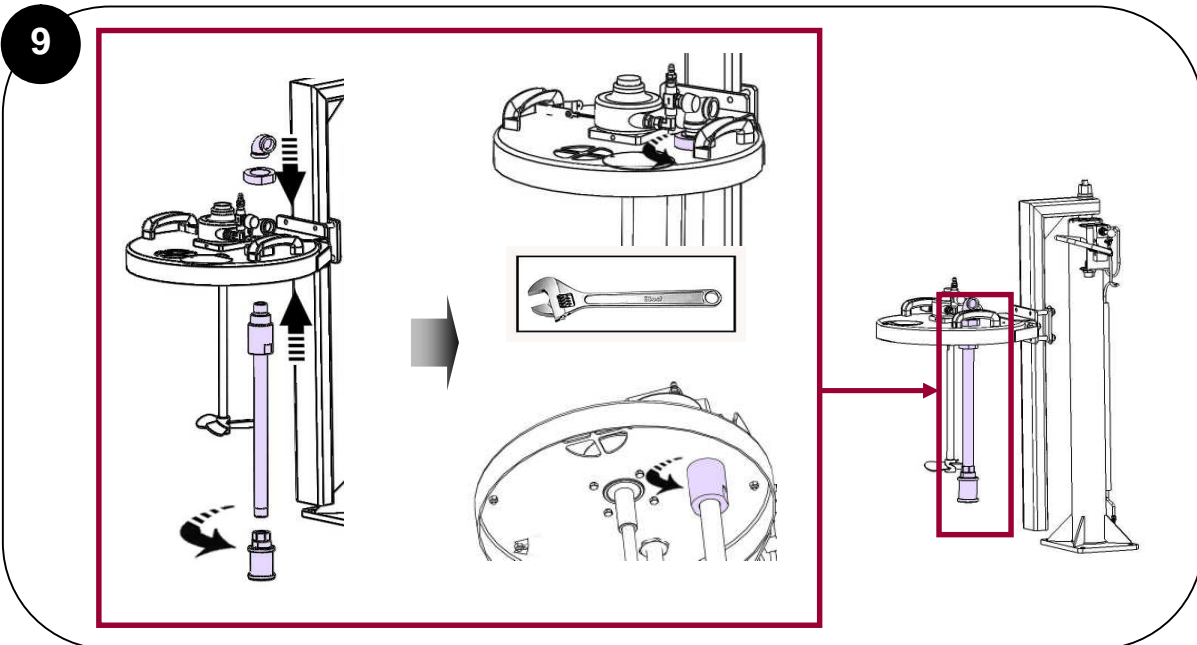
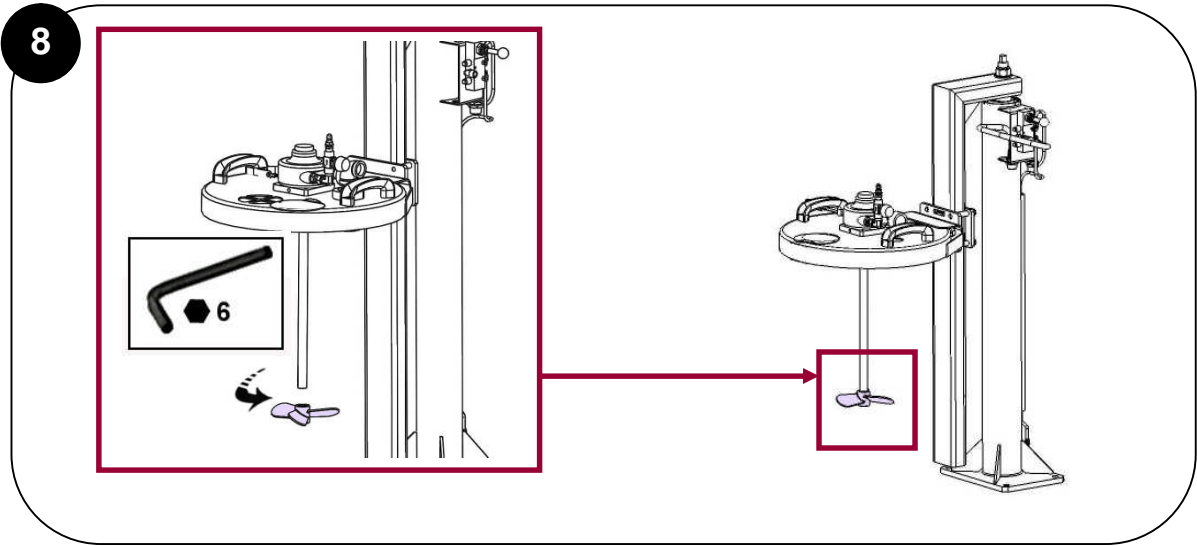

11

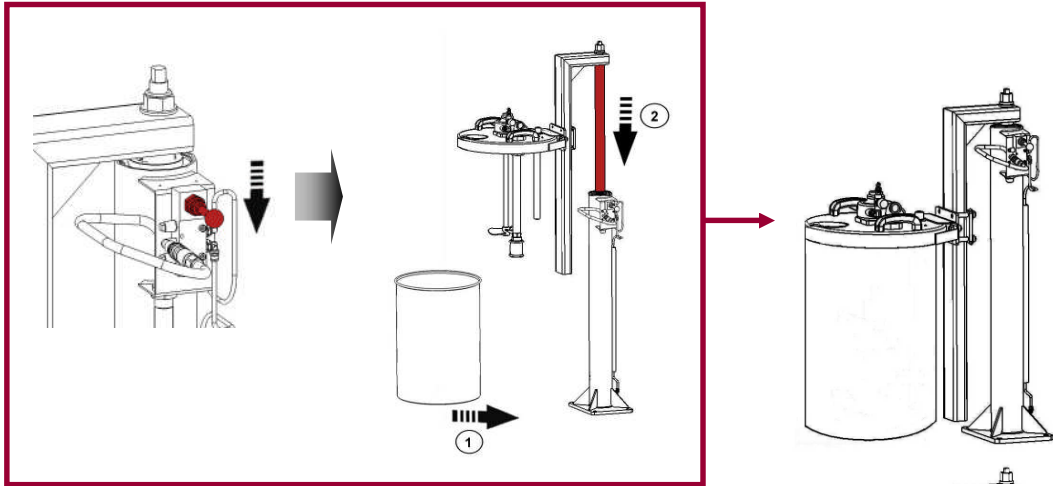

12

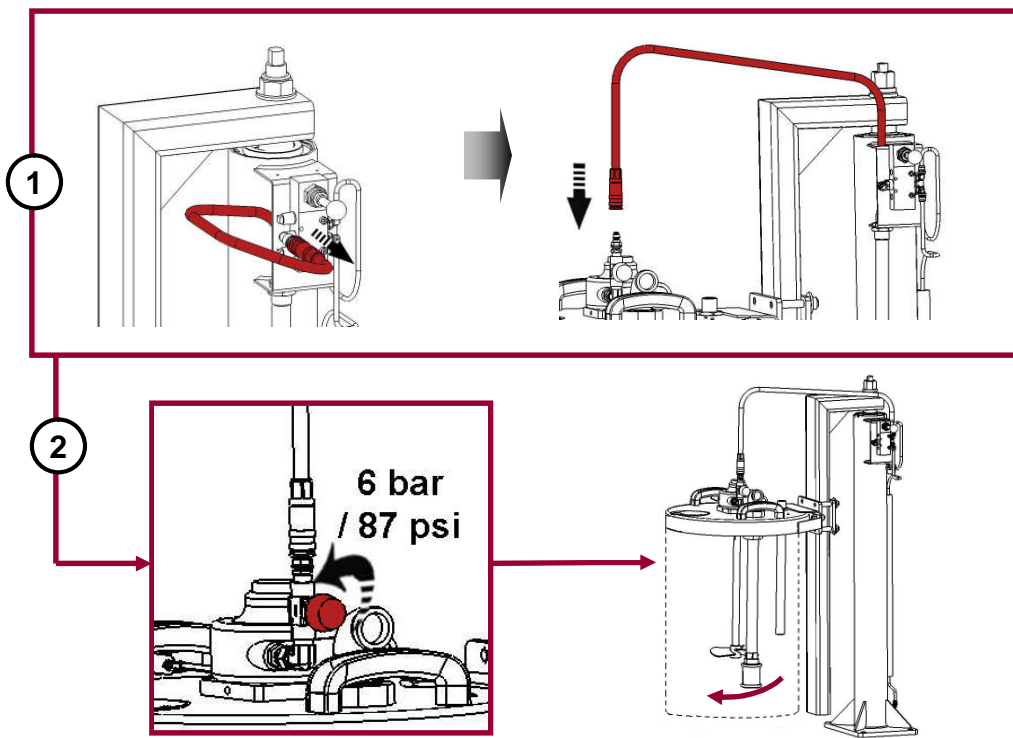



**DEMONTAGE / REMONTAGE
DISASSEMBLY / REASSEMBLY
DEMONTAGE / MONTAGE
DESMONTAJE / MONTAJE**

**UNITE D'AGITATION / AGITATION UNIT
RÜHRANLAGEN / UNIDAD DE AGITACIÓN
40 L / 10.6 US GAL
CYCLIX II**

NOTICE ORIGINALE
/ TRANSLATION FROM THE ORIGINAL MANUAL
/ ÜBERSETZUNG DER ORIGINAL BETRIEBSANLEITUNG
/ TRADUCCIÓN DEL LIBRO ORIGINAL

L'équipement est soumis à la directive ATEX et ne doit en aucun cas être modifié. Le non-respect de cette préconisation ne saurait engager notre responsabilité.
/ The equipment is manufactured under the ATEX agreement and should not be modified. KREMLIN REXSON will not be held responsible for any failure to comply with that instruction.
/ Das Gerät hat die ATEX Zulassung, deswegen darf die Maschine nie geändert werden. Die Nichtbeachtung dieser Präkonisation könnte unsere Verantwortung nicht übernehmen.
/ El equipo es de conformidad a la directiva ATEX y no debe ser modificada, en ningún caso. KREMLIN REXSON no se hace responsable de que esta preconización no sea respetada.

Des protecteurs (capot moteur, protecteur d'accouplement, carters,...) sont mis en place pour une utilisation sûre du matériel.
Le fabricant ne peut être tenu pour responsable en cas de dommages corporels ainsi que des pannes et / ou endommagement du matériel résultant de la destruction, de l'occultation ou du retrait total ou partiel des protecteurs.
/ Guards (motor cover, coupling shields, connectors,...) have been designed for a safe use of the equipment. The manufacturer will not be held responsible for bodily injury or failure and / or property damage due to destruction, the overshadowing or the partial or total removal of the guards
/ Schutzvorrichtungen an diesem Gerät (wie Motorhaube, Kupplungsschutz, Gehäuse, ggf. Erdungskabel, sowie weitere Vorrichtungen) wurden für eine sichere Benutzung dieses Gerätes entwickelt und angebracht. Der Hersteller lehnt jede Verantwortung für Körperschäden, Fehlfunktionen, Beschädigung der Geräte, und jegliche andere Fehler ab, die durch die ganze oder teilweise Entfernung, Modifikation oder unsachgemäße Handhabung der Schutzvorrichtungen oder anderen Geräteteilen entstehen.
/ Protectores (capó motor, protector de acoplamiento, cárteres,...) se colocan para una utilización segura del material. El fabricante no se hace responsable, en caso de daños personales, así como de las averías y / o daños del material, resultantes de la destrucción, la ocultación o la retirada total o parcial de los protectores.

Vous aurez besoin de / you need / Werkzeugaufstellung / Vd necesita :

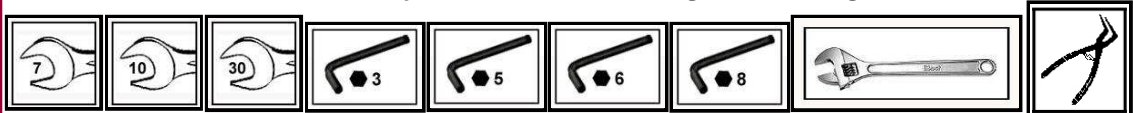

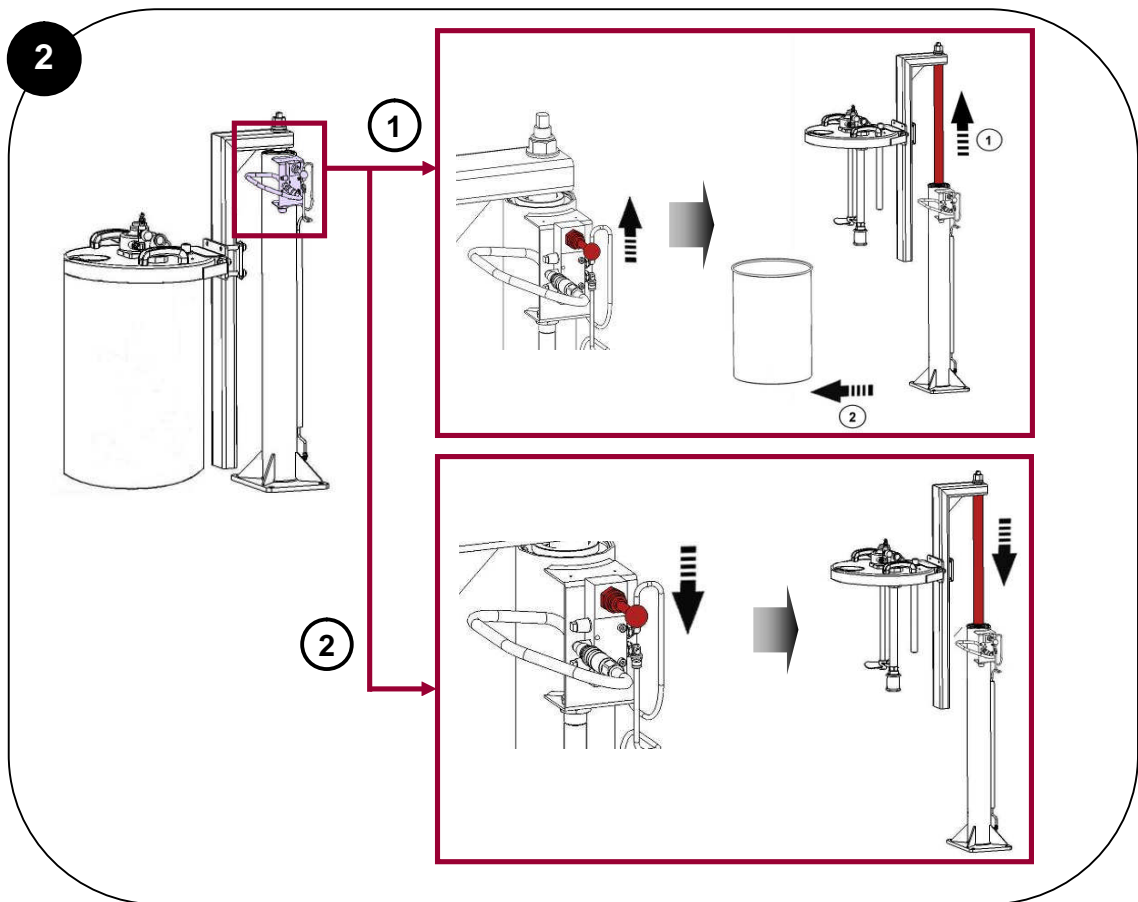
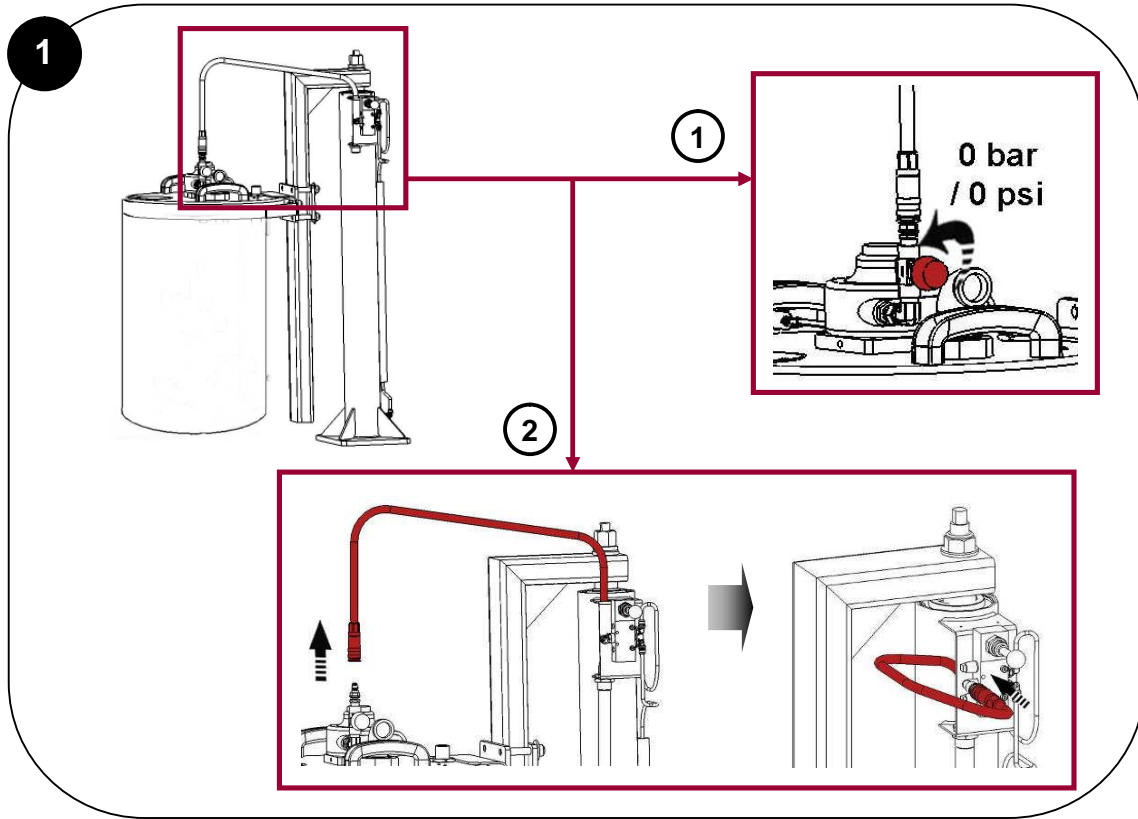

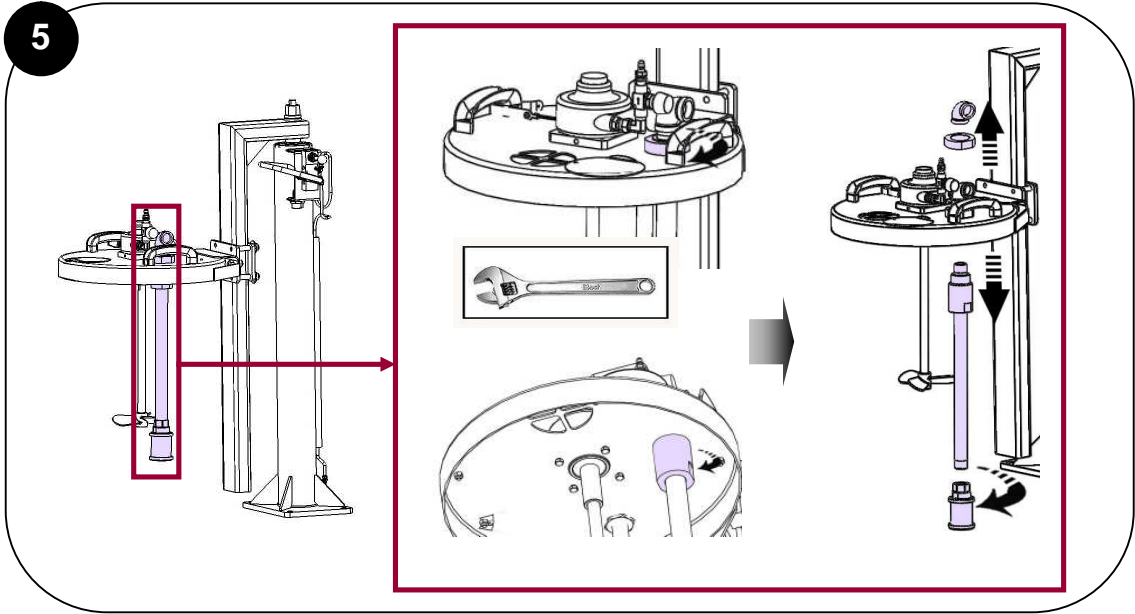
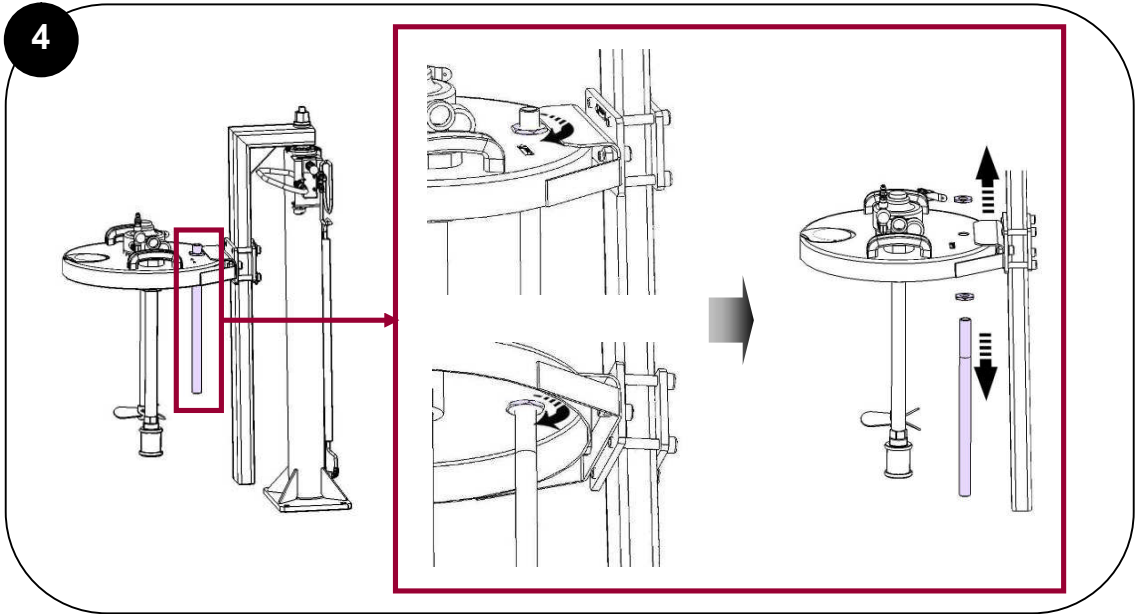
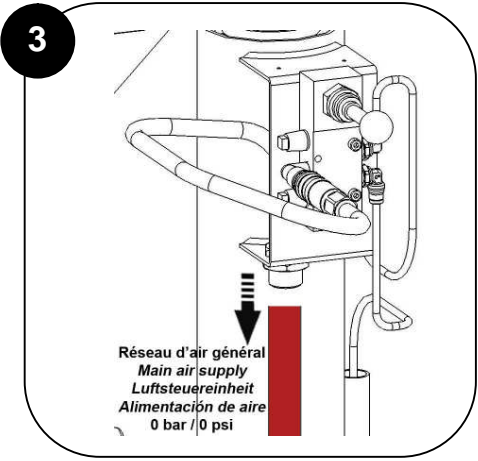

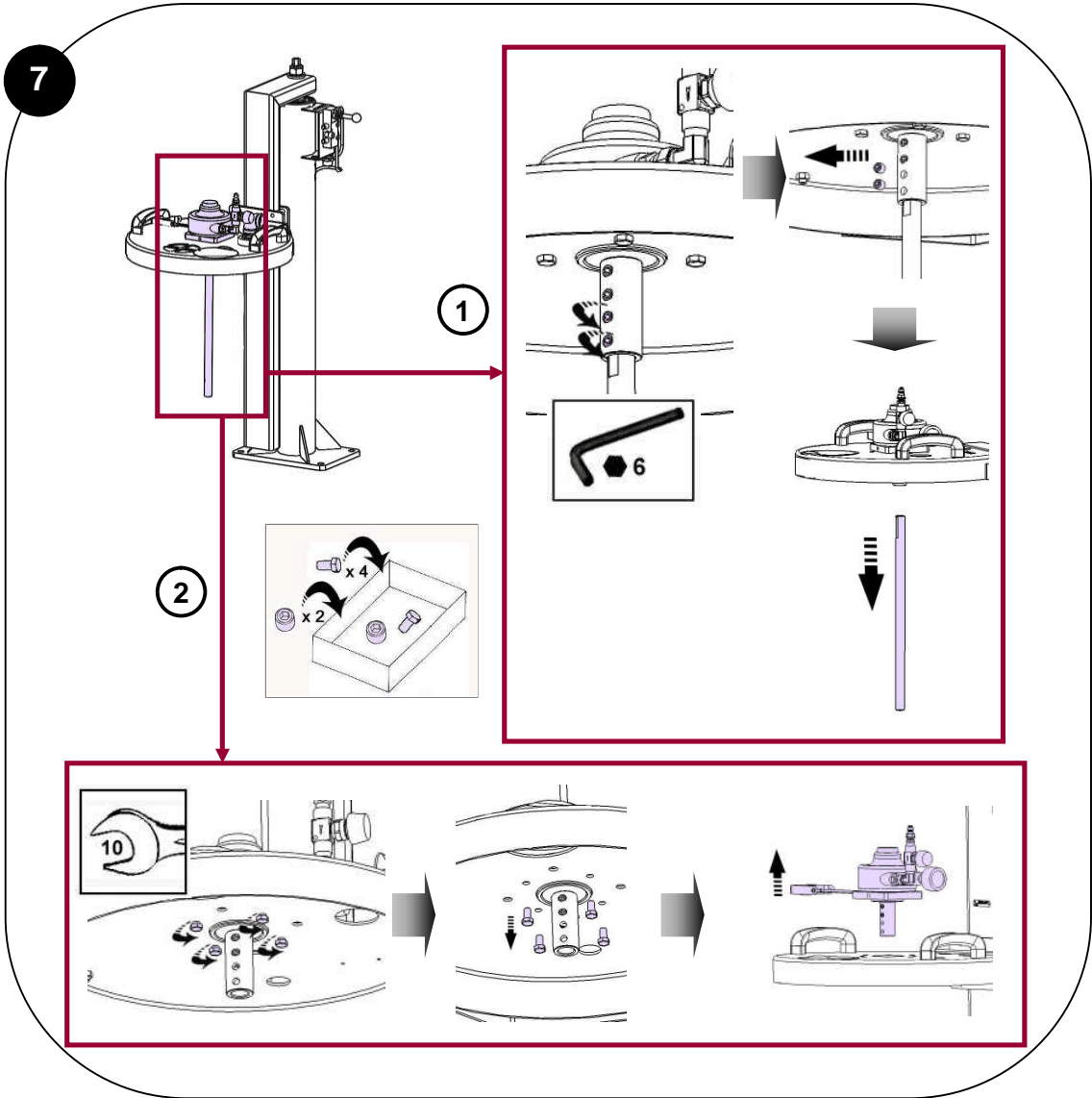
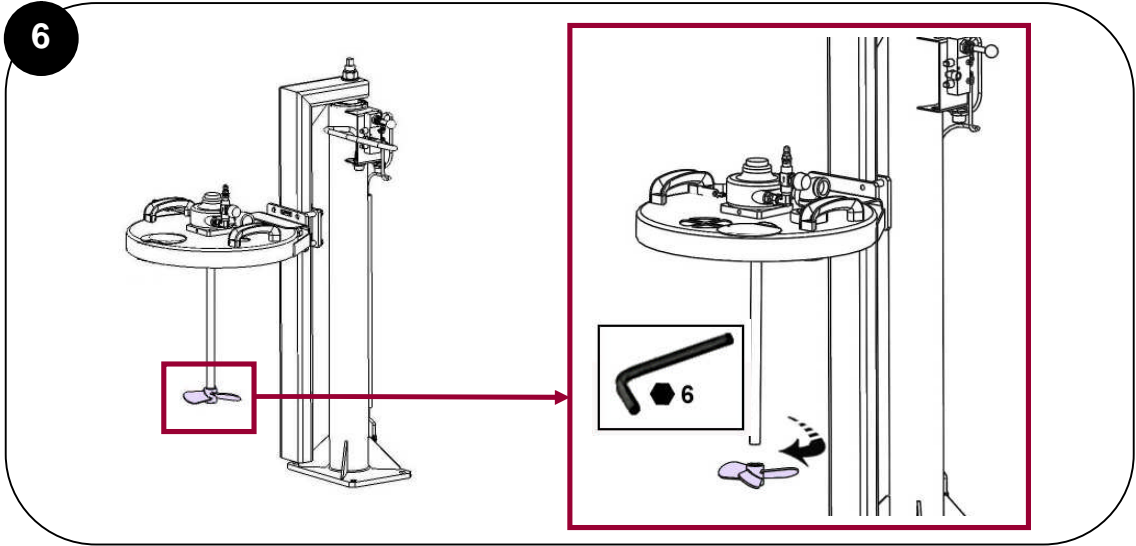

8

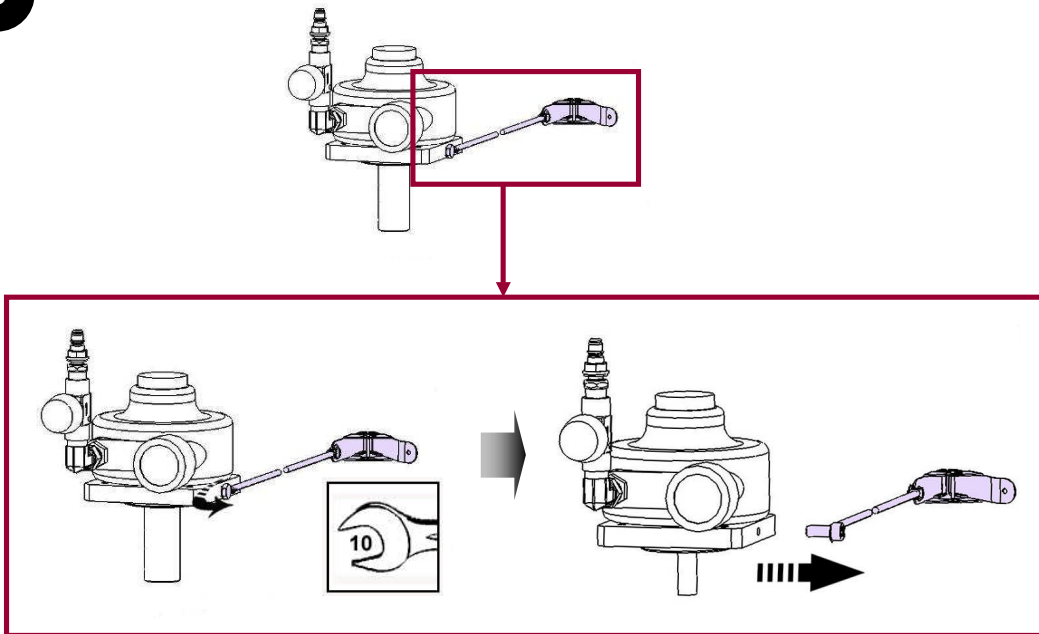

9

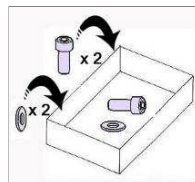
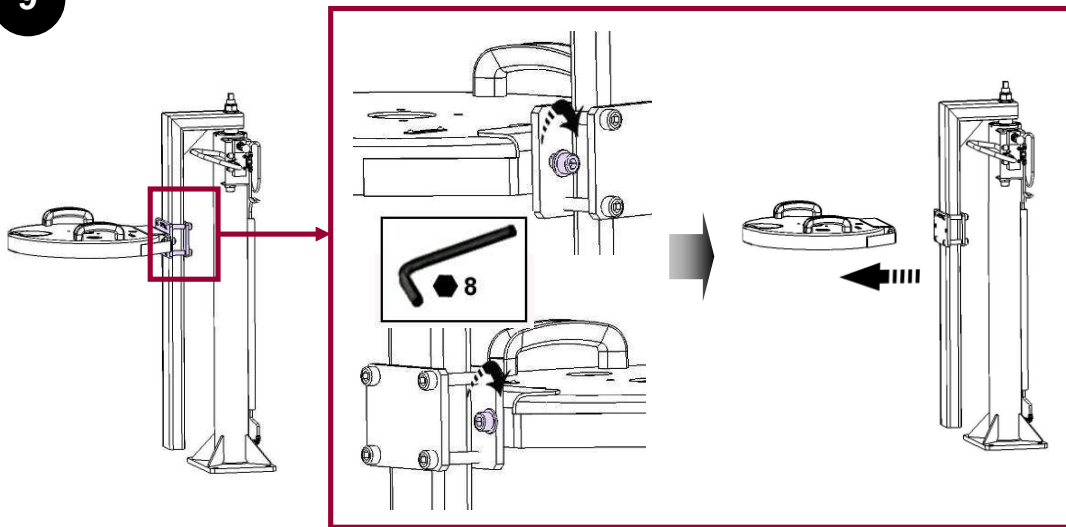

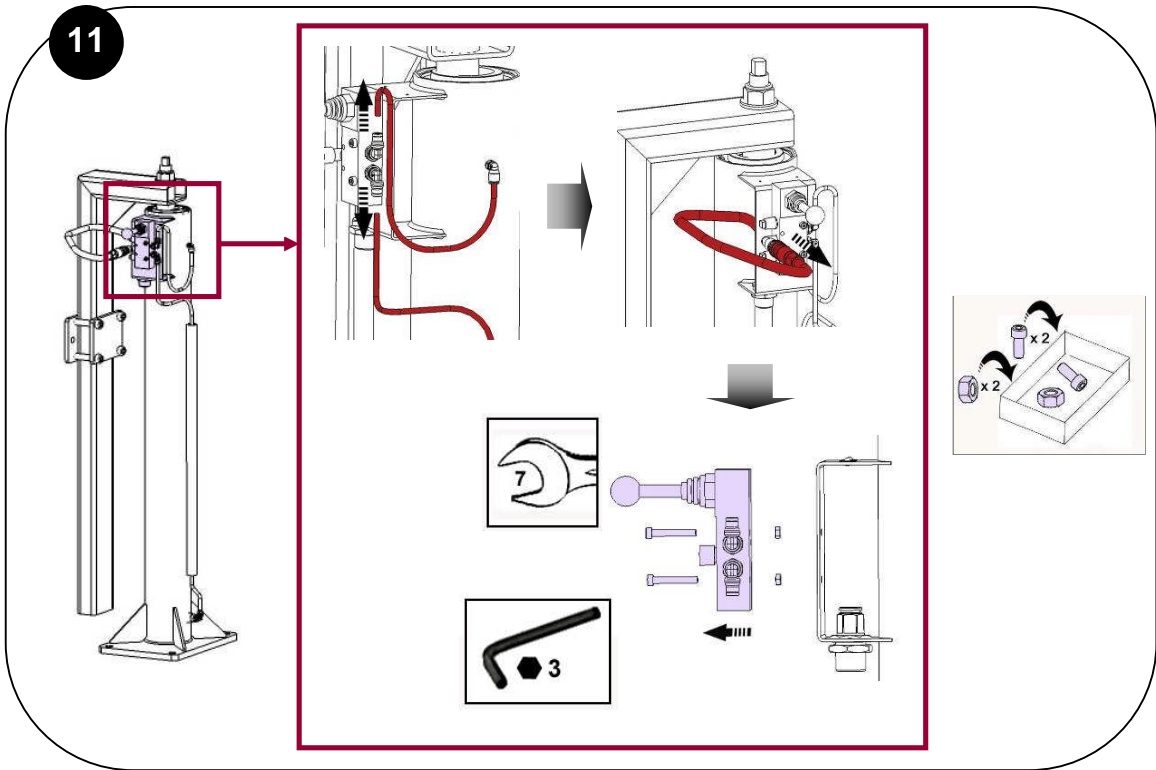
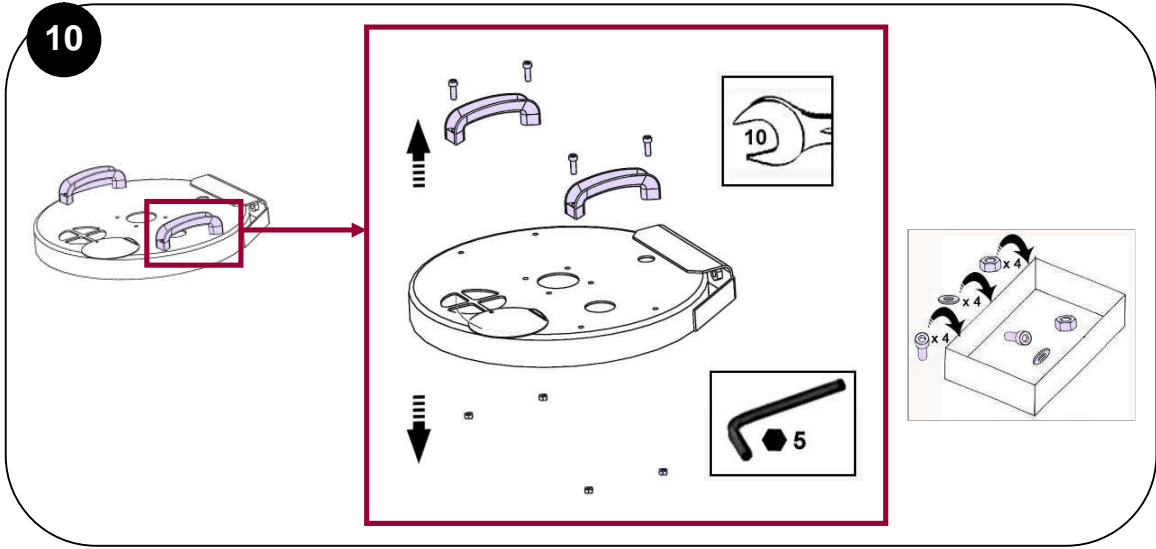

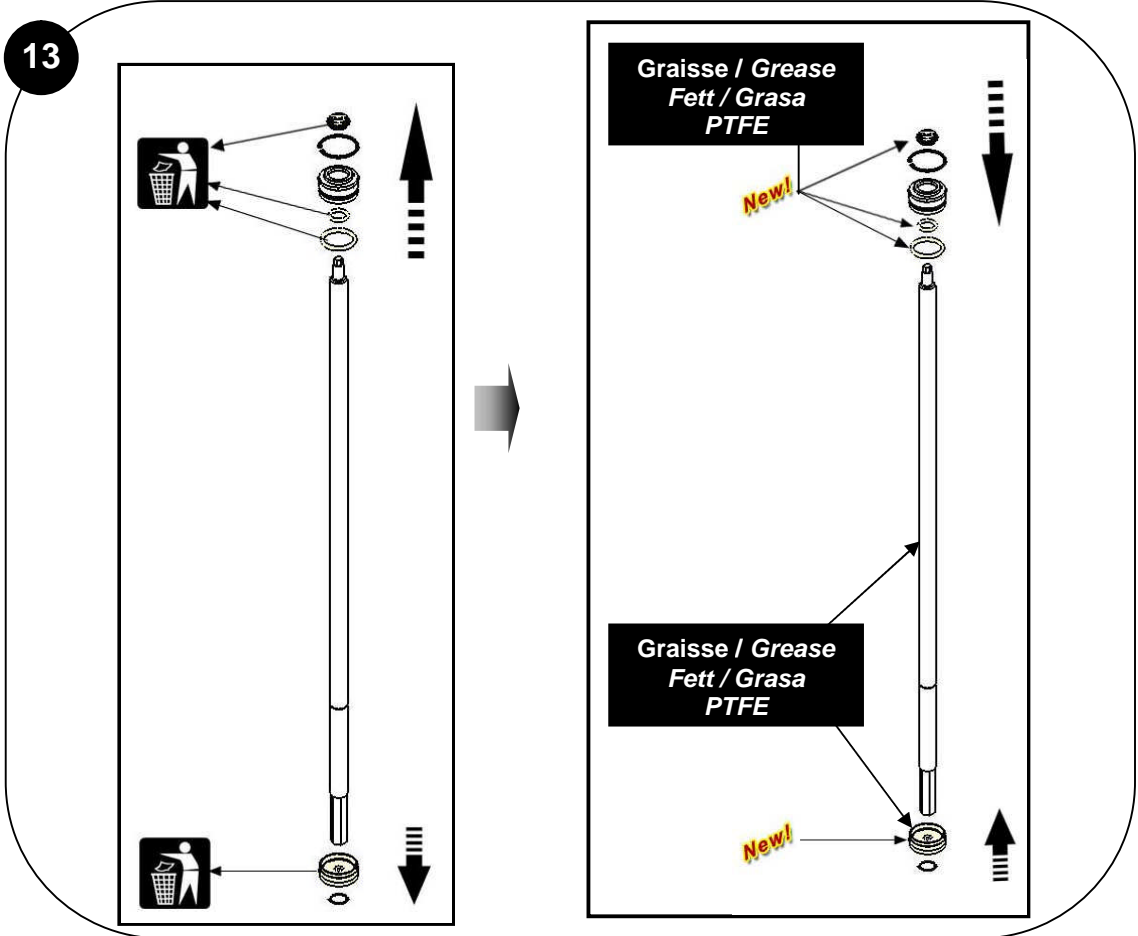
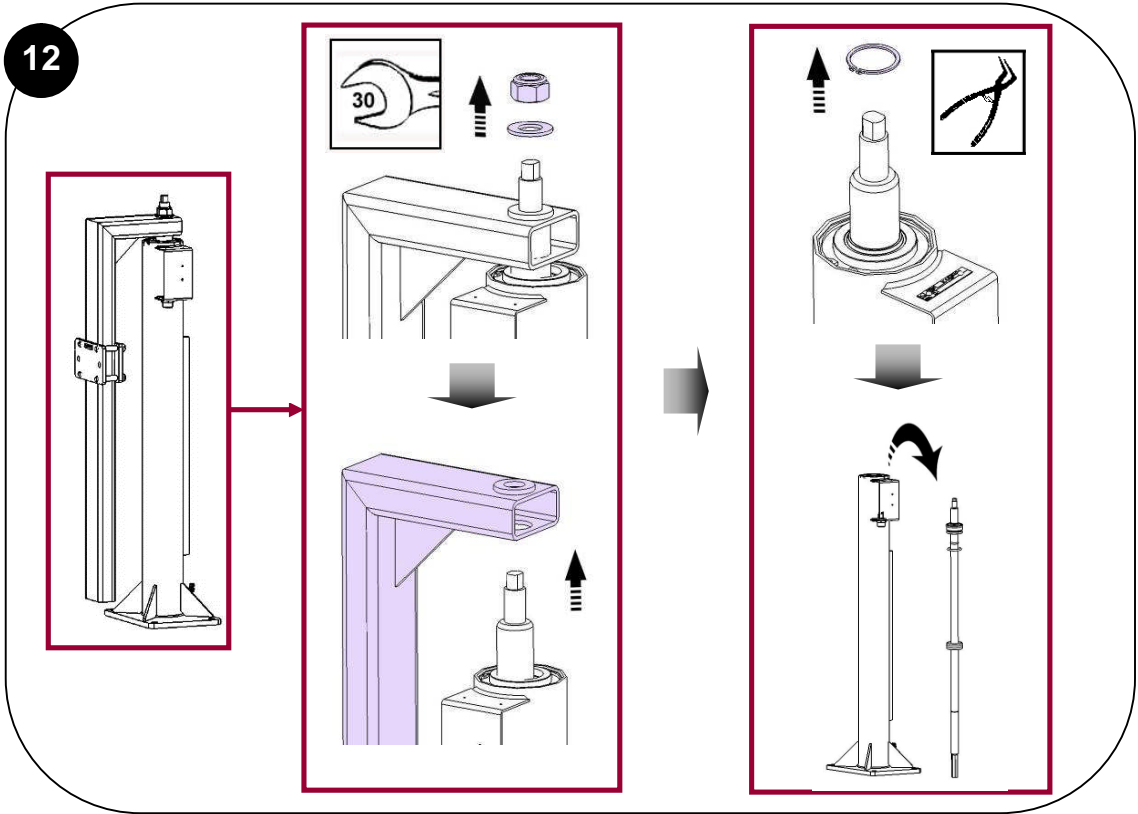

Des protecteurs (capot moteur, protecteur d'accouplement, carters,...) sont mis en place pour une utilisation sûre du matériel.

Le fabricant ne peut être tenu pour responsable en cas de dommages corporels ainsi que des pannes et / ou endommagement du matériel résultant de la destruction, de l'occultation ou du retrait total ou partiel des protecteurs.

/ Guards (motor cover, coupling shields, connectors,...) have been designed for a safe use of the equipment. The manufacturer will not be held responsible for bodily injury or failure and / or property damage due to destruction, the overshadowing or the partial or total removal of the guards

/ Schutzvorrichtungen an diesem Gerät (wie Motorhaube, Kupplungsschutz, Gehäuse, ggf. Erdungskabel, sowie weitere Vorrichtungen) wurden für eine sichere Benutzung dieses Gerätes entwickelt und angebracht. Der Hersteller lehnt jede Verantwortung für Körperschäden, Fehlfunktionen, Beschädigung der Geräte, und jegliche andere Fehler ab, die durch die ganze oder teilweise Entfernung, Modifikation oder unsachgemäße Handhabung der Schutzvorrichtungen oder anderen Geräteteilen entstehen.

/ Protectores (capó motor, protector de acoplamiento, cárteres,...) se colocan para una utilización segura del material. El fabricante no se hace responsable, en caso de daños personales, así como de las averías y / o daños del material, resultantes de la destrucción, la ocultación o la retirada total o parcial de los protectores.

14

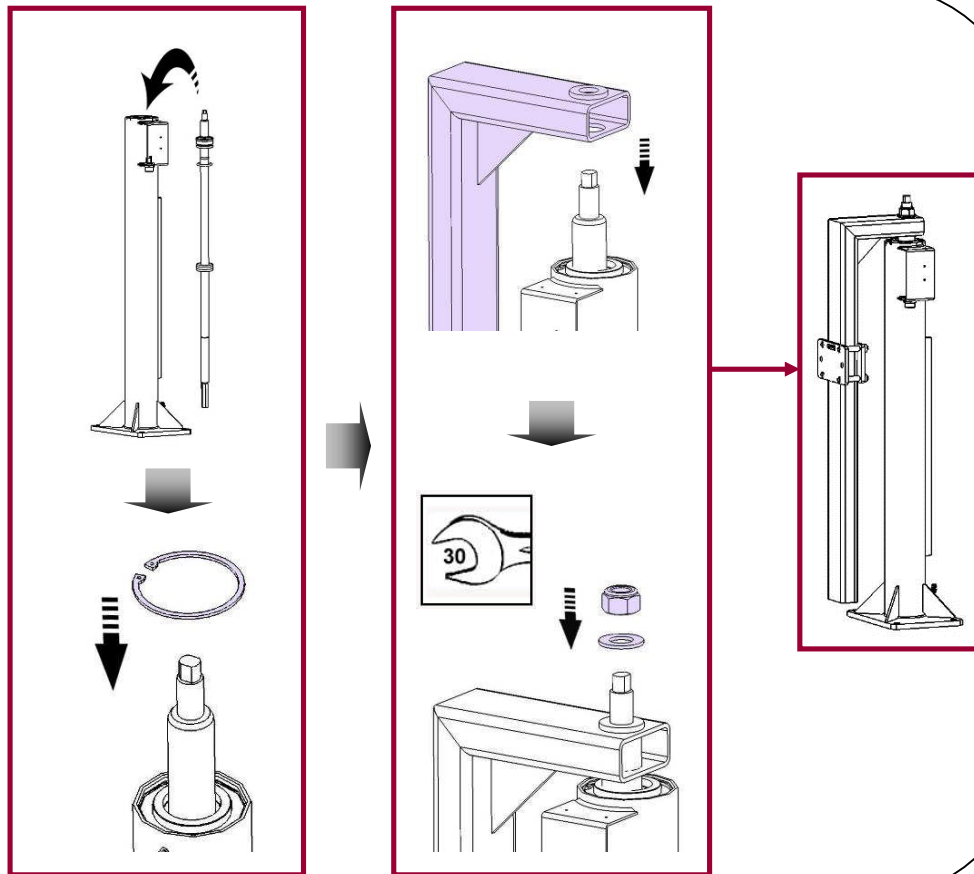

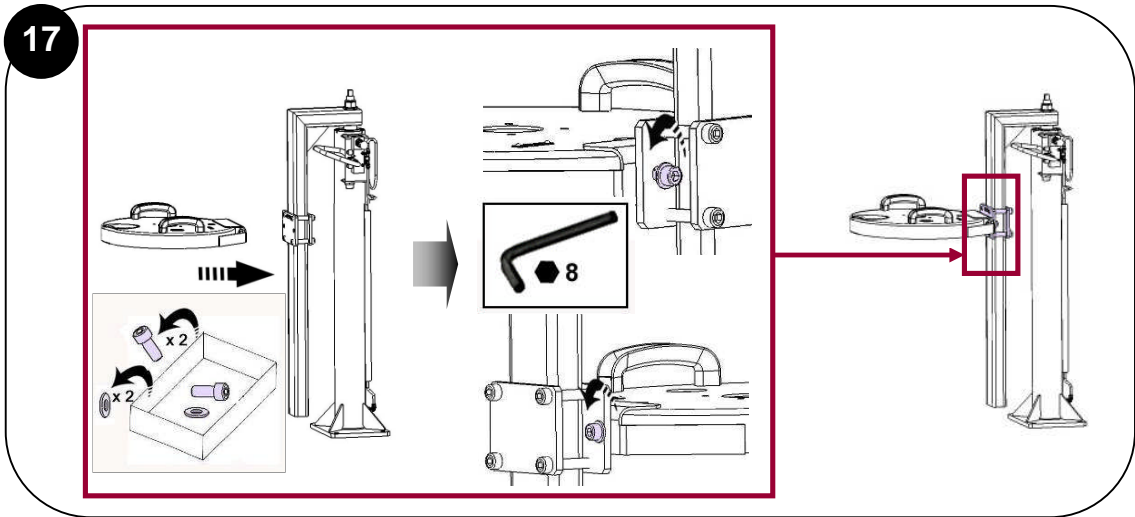
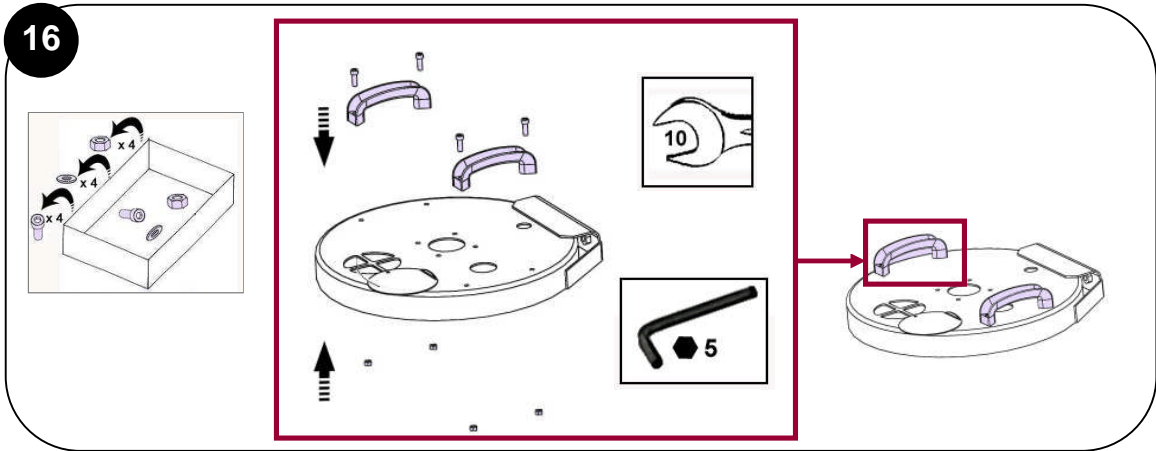
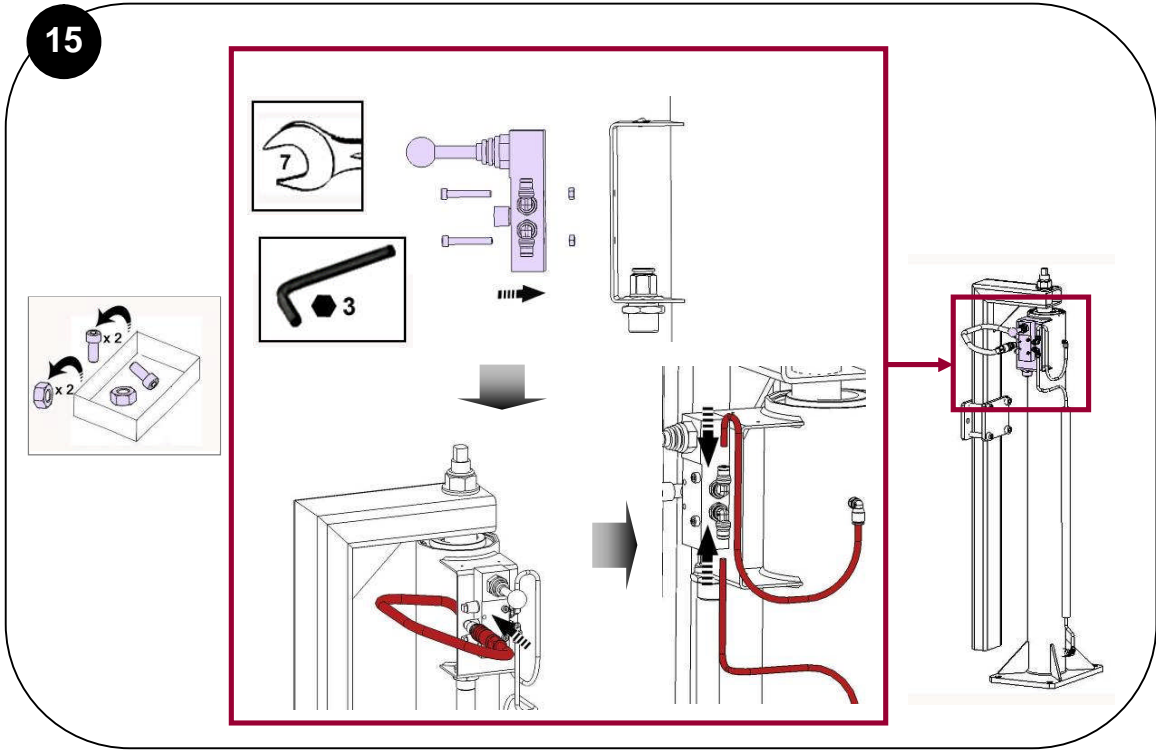

18

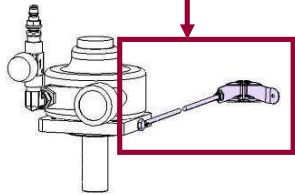
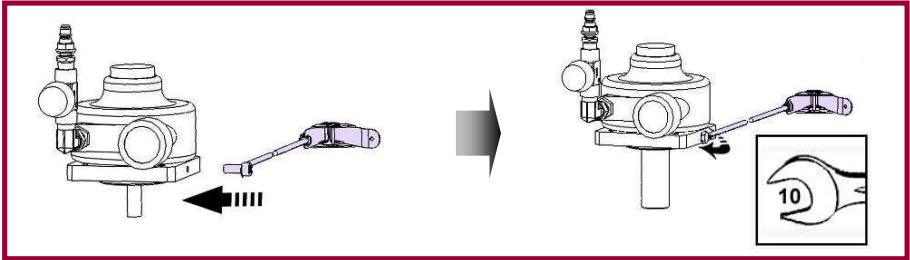

19

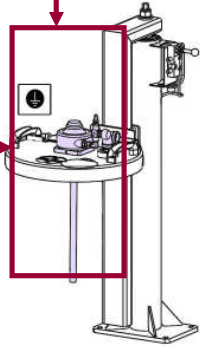
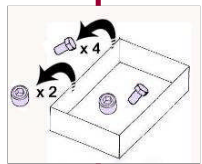
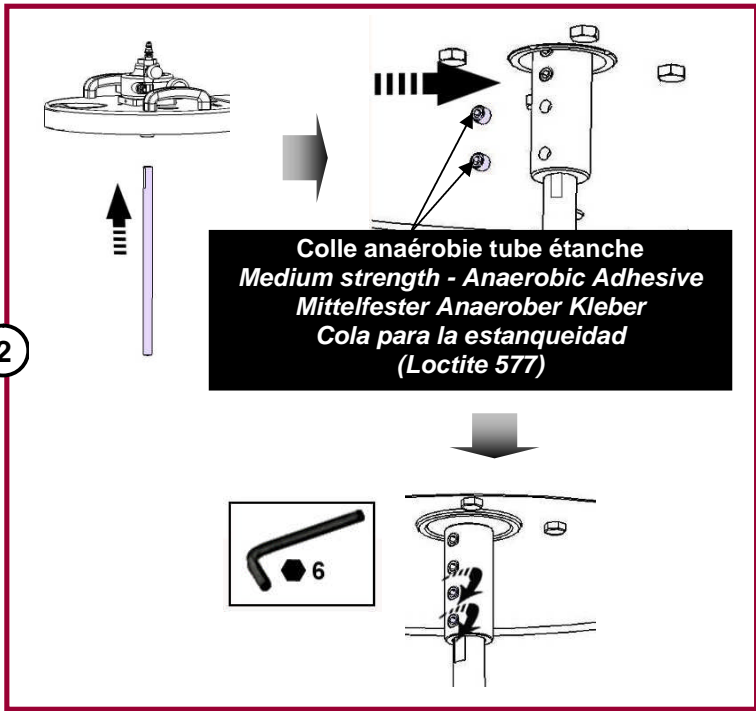
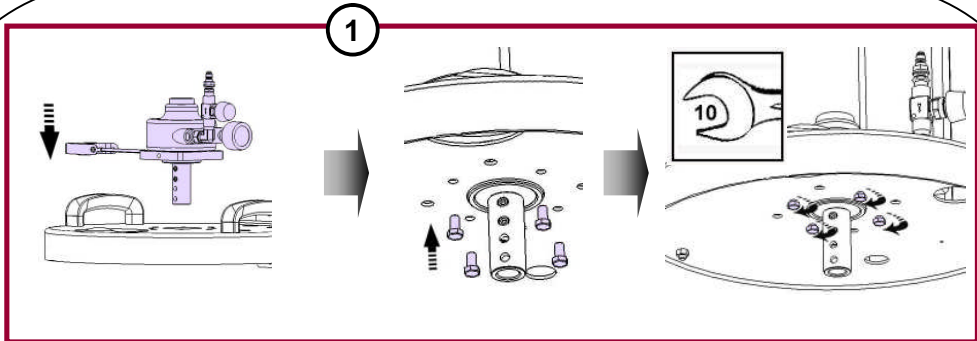

20

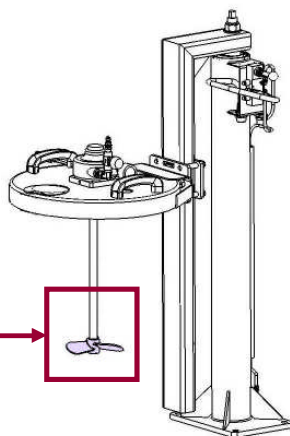
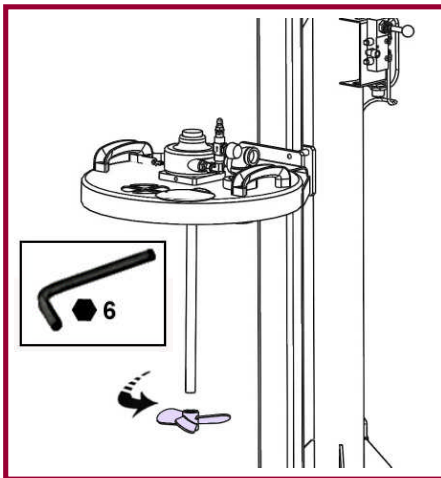

21

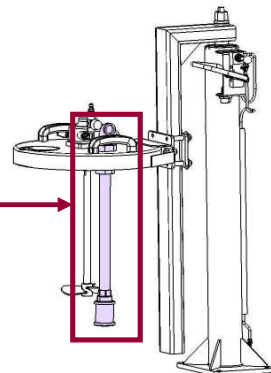
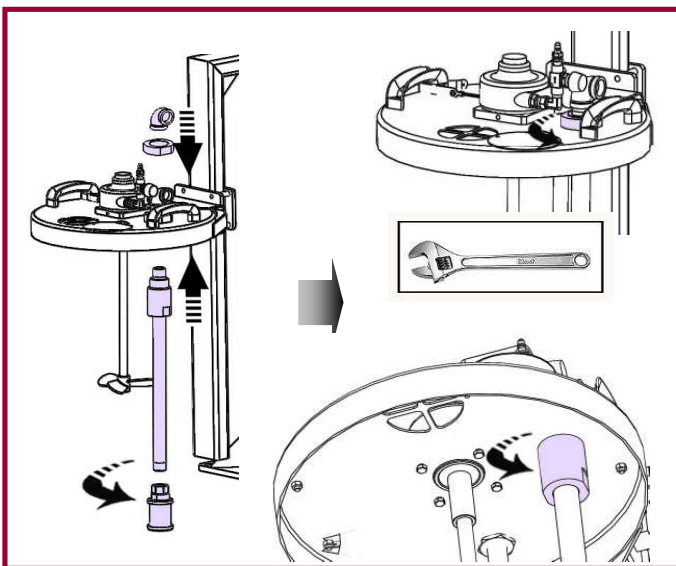

22

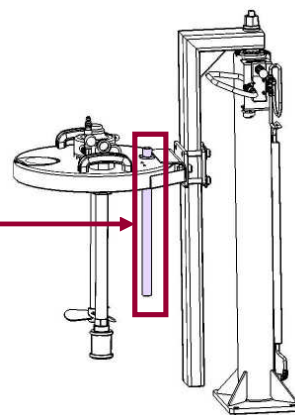
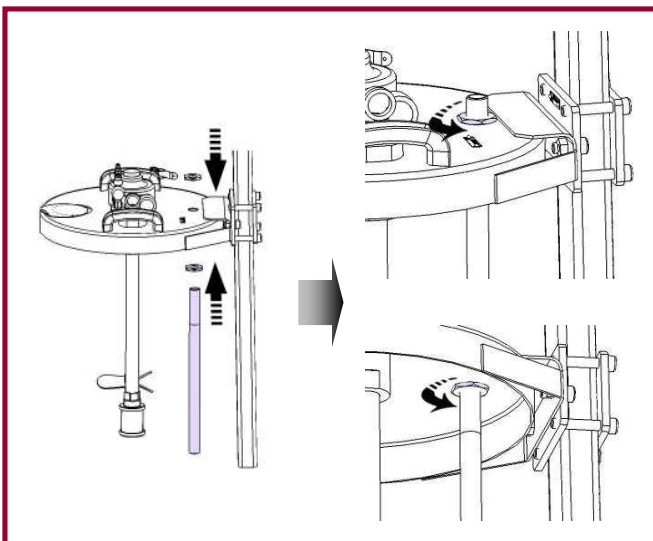

23

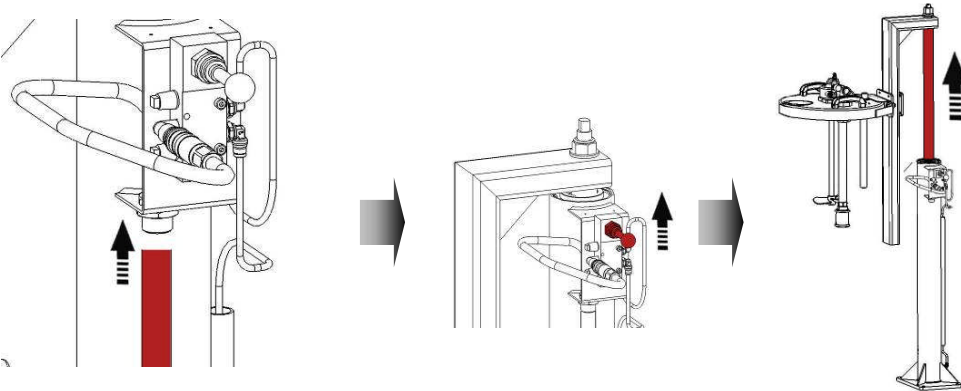

24

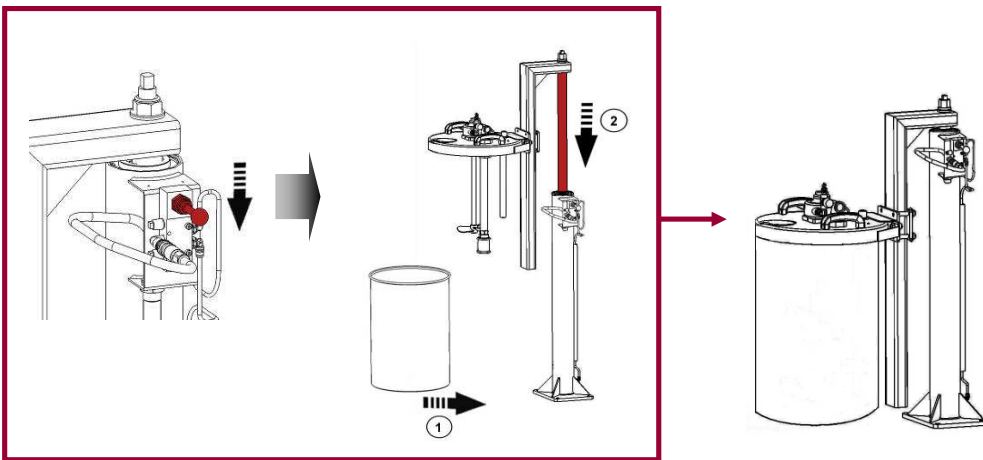

25

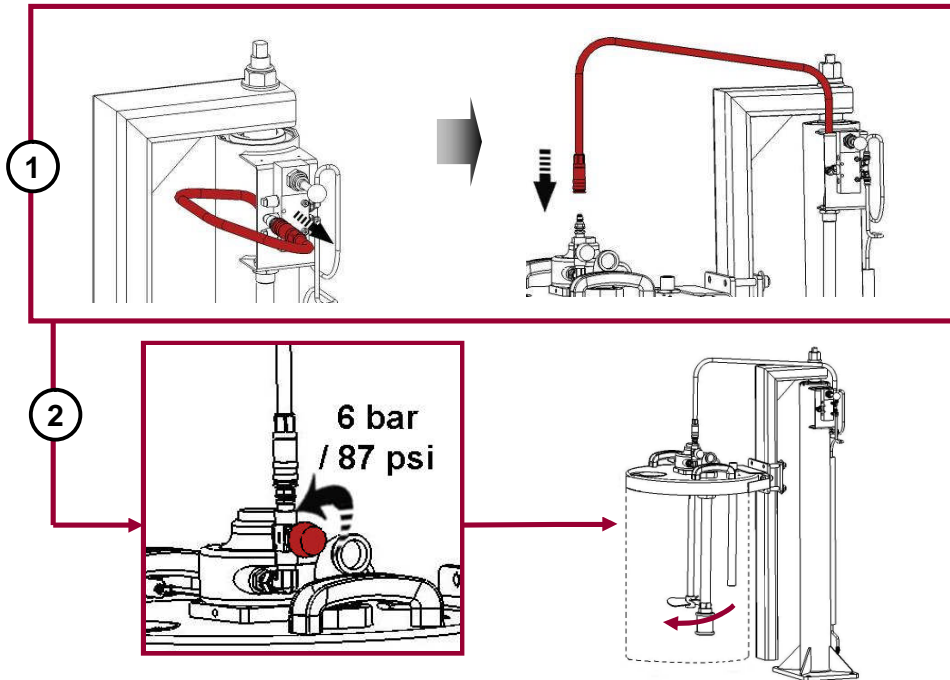

**PIECES DE RECHANGE
SPARE PARTS
ERSATZTEILLISTE
PIEZAS DE REPUESTO**

**UNITE D'AGITATION / AGITATION UNIT
RÜHRANLAGEN / UNIDAD DE AGITACIÓN
CYCLIX II**

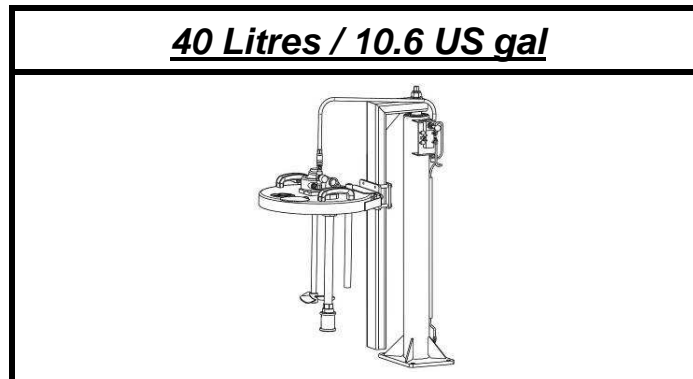

151 081 000

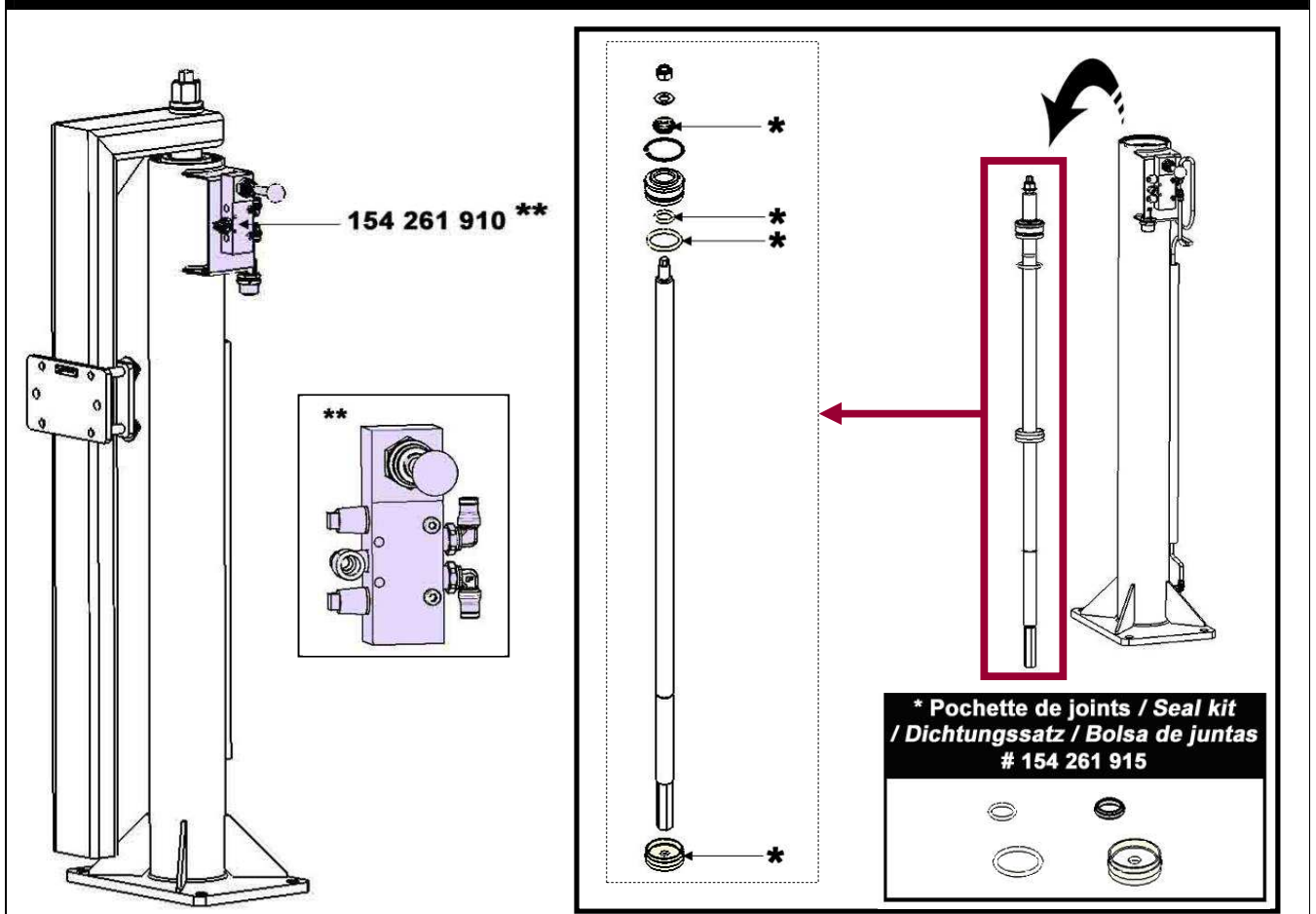

154 261 600

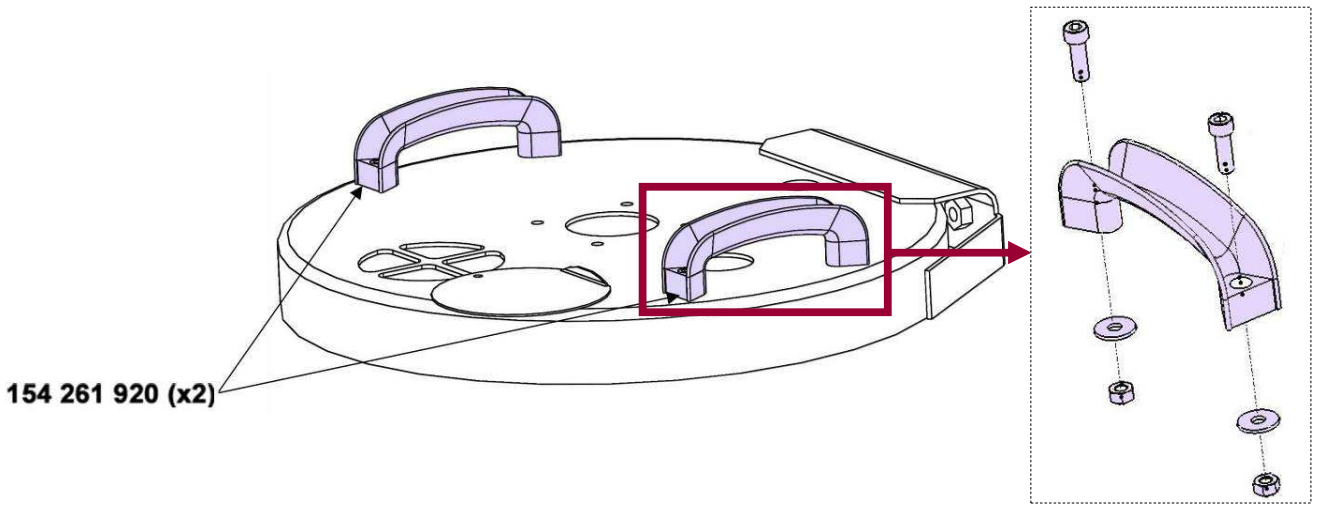

154 261 700

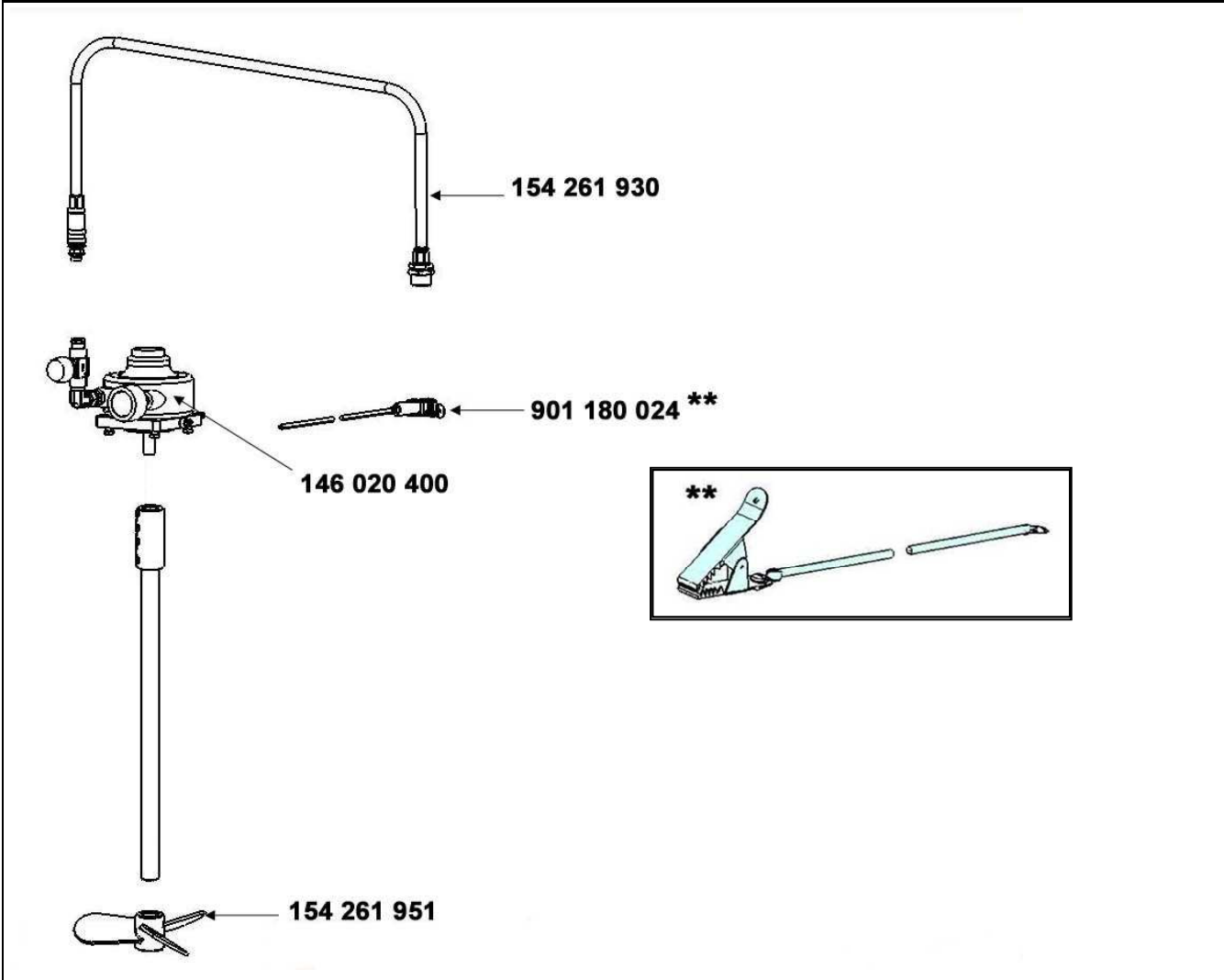

154 261 800

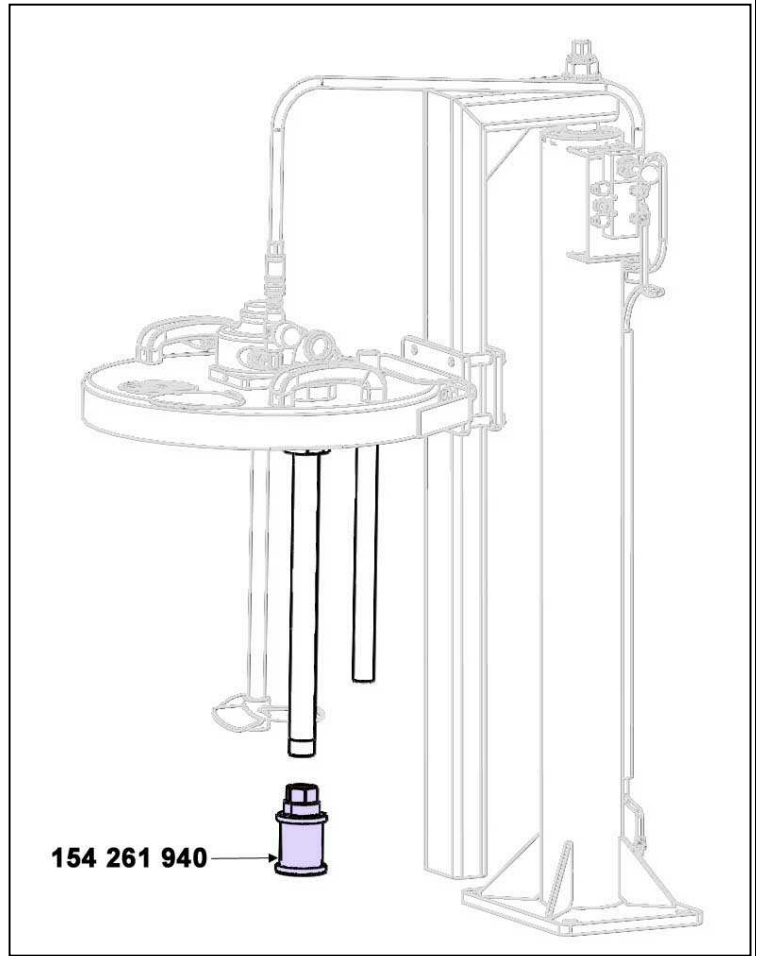
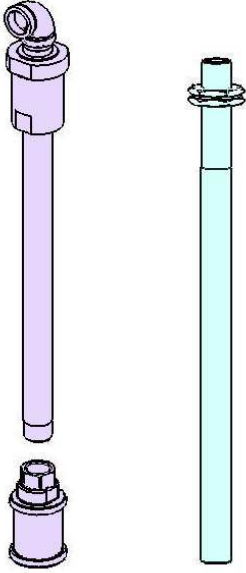

OPTIONS / OPTIONAL/ OPTIONEN / OPCIONES

Bidon 2 L - Huile HP 150
2 L Drum - Oil HP 150
2 L Behälter - Öl HP 150
Bidón 2 L - Aceite HP 150
149 990 017



Table à rouleau / Roller plate
Walzertisch / Mesa con rodillos
151 098 100



Ensemble récupération d'huile
Oil recovery assembly
Öl Rückgewinnung kplt.
Conjunto recuperación aceite
154 261 996



Lubrificateur d'air 1/4 + support
Air lubricator 1/4 + support
Luftschmirer 1/4 + Halterung
Lubricador de aire 1/4 + soporte
154 261 997





**ENTRETIEN PREVENTIF
PREVENTIVE MAINTENANCE
VORBEUGENDE WARTUNG
MANTENIMIENTO
PREVENTIVO**

**UNITE D'AGITATION / AGITATION UNIT
RÜHRWERKE / UNIDAD DE AGITACIÓN
40 & 200 L / 10.6 & 52.8 US GAL
CYCLIX II**

NOTICE ORIGINALE
/ TRANSLATION FROM THE ORIGINAL MANUAL
/ ÜBERSETZUNG DER ORIGINAL BETRIEBSANLEITUNG
/ TRADUCCIÓN DEL LIBRO ORIGINAL

L'équipement est soumis à la directive ATEX et ne doit en aucun cas être modifié. Le non-respect de cette préconisation ne saurait engager notre responsabilité.

/ The equipment is manufactured under the ATEX agreement and should not be modified. KREMLIN REXSON will not be held responsible for any failure to comply with that instruction.

/ Dieses Anlage hat die ATEX Zulassung, deswegen darf sie nie verändert werden. Bei Nichtbeachtung dieser Anordnung, können wir keine Verantwortung für eine einwandfreie, regelkonforme Funktion der Anlage übernehmen.

/ El equipo es de conformidad a la directiva ATEX y no debe ser modificada, en ningún caso. KREMLIN REXSON no se hace responsable de que esta preconización no sea respetada.

Des protecteurs (capot moteur, protecteur d'accouplement, carters,...) sont mis en place pour une utilisation sûre du matériel.

Le fabricant ne peut être tenu pour responsable en cas de dommages corporels ainsi que des pannes et / ou endommagement du matériel résultant de la destruction, de l'occultation ou du retrait total ou partiel des protecteurs.

/ Guards (motor cover, coupling shields, connectors,...) have been designed for a safe use of the equipment. The manufacturer will not be held responsible for bodily injury or failure and / or property damage due to destruction, the overshadowing or the partial or total removal of the guards

/ Schutzvorrichtungen an diesem Gerät (wie Motorhaube, Kupplungsschutz, Gehäuse, ggf. Erdungskabel, sowie weitere Vorrichtungen) wurden für eine sichere Benutzung dieses Gerätes entwickelt und angebracht. Der Hersteller lehnt jede Verantwortung für Körperschäden, Fehlfunktionen, Beschädigung der Geräte, und jegliche andere Fehler ab, die durch die ganze oder teilweise Entfernung, Modifikation oder unsachgemäße Handhabung der Schutzvorrichtungen oder anderen Geräteteilen entstehen.

/ Protectores (capó motor, protector de acoplamiento, cárteres,...) se colocan para una utilización segura del material. El fabricante no se hace responsable, en caso de daños personales, así como de las averías y / o daños del material, resultantes de la destrucción, la ocultación o la retirada total o parcial de los protectores.

AVANT CHAQUE OPERATION DE MAINTENANCE
DO THIS BEFORE ANY MAINTENANCE ACTION
VOR JEDER WARTUNGSARBEIT IST FOLGENDES ZU TUN
ANTES DE CADA OPERACIÓN DE MANTENIMIENTO

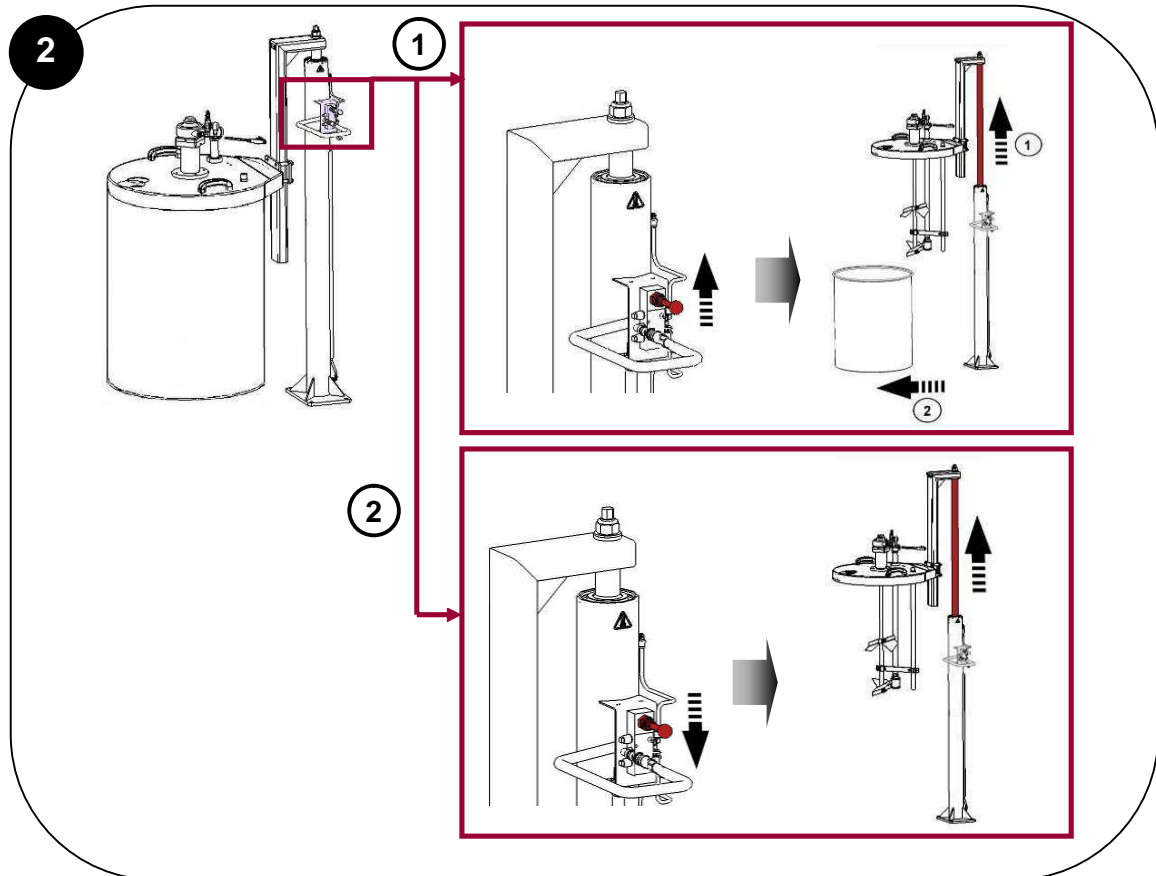
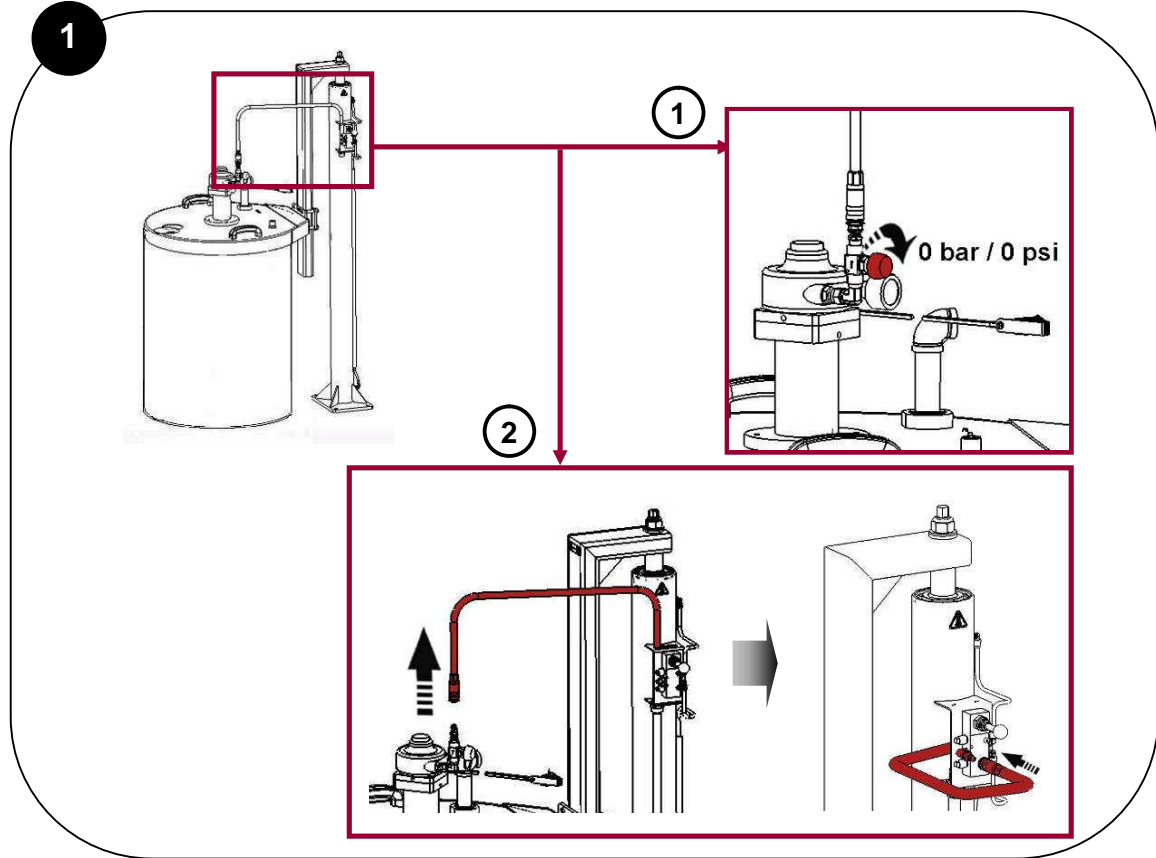

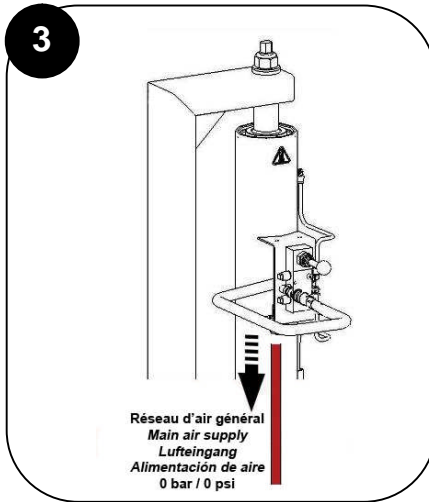

TOUS LES JOURS / DAILY TASKS / TÄGLICH / DIARIO

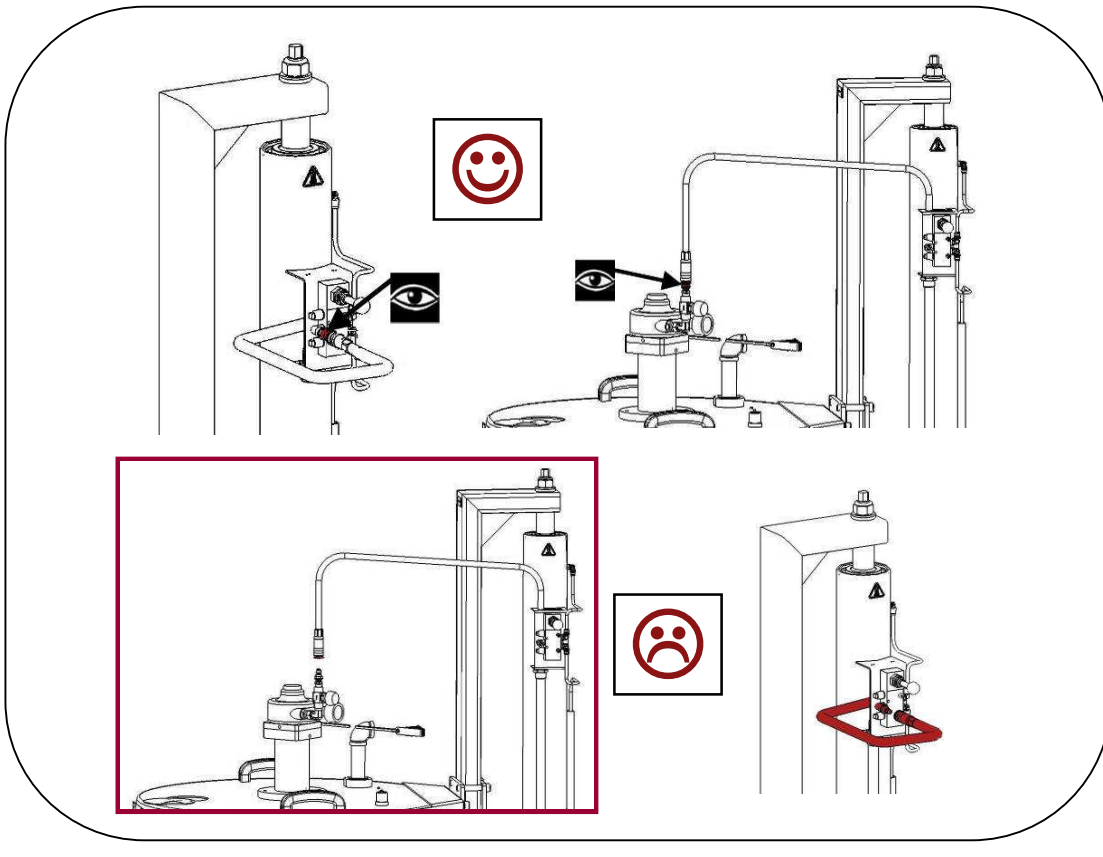
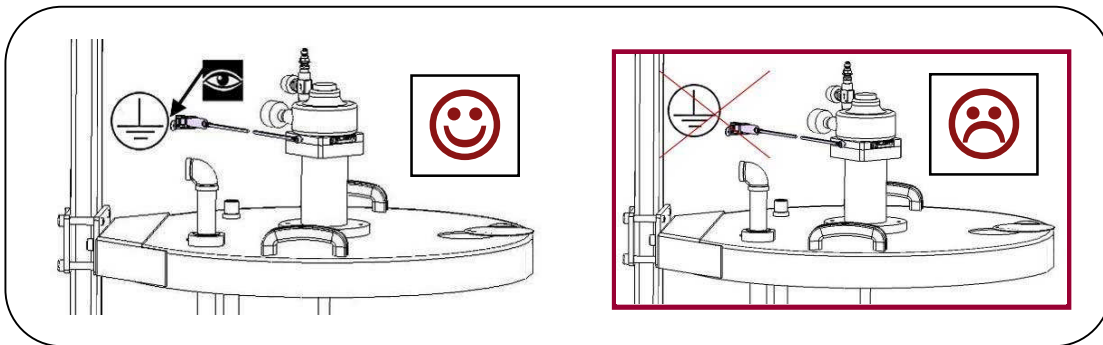

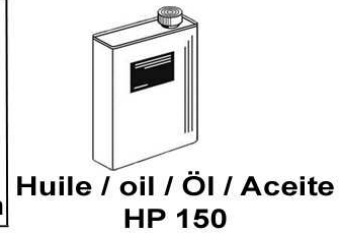
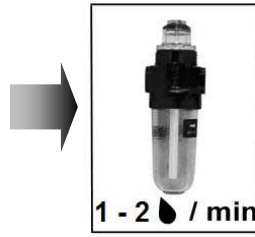
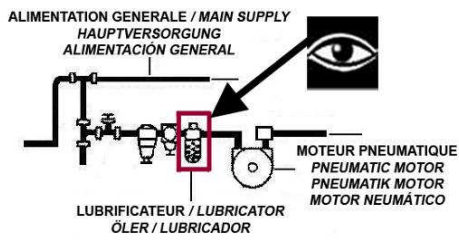

40 L

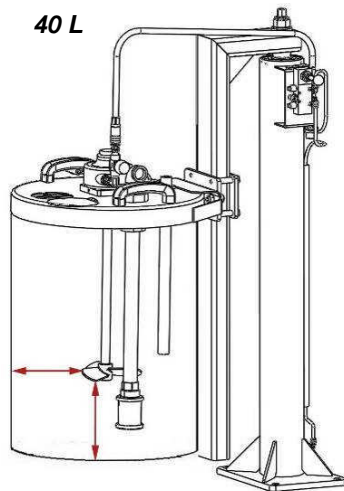

200 L

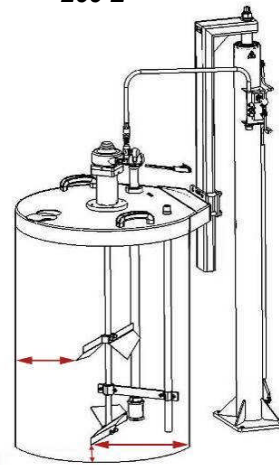

40 L

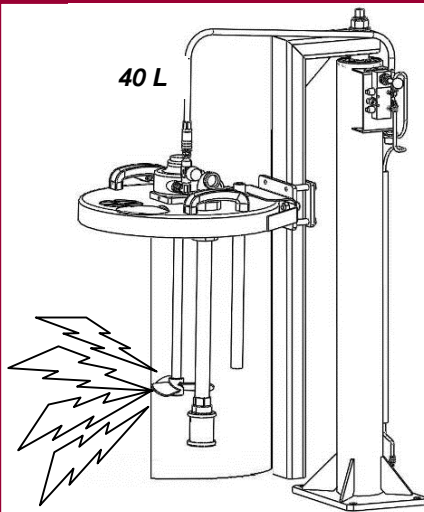

200 L

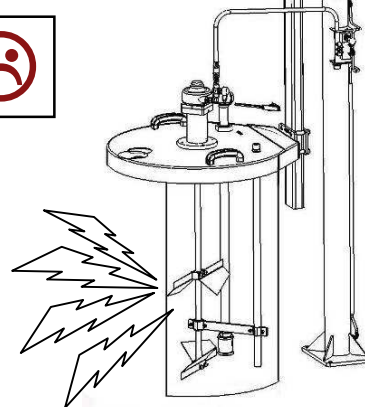

HEBDOMADAIRE / WEEKLY TASKS / WÖCHENTLICH / SEMANAL

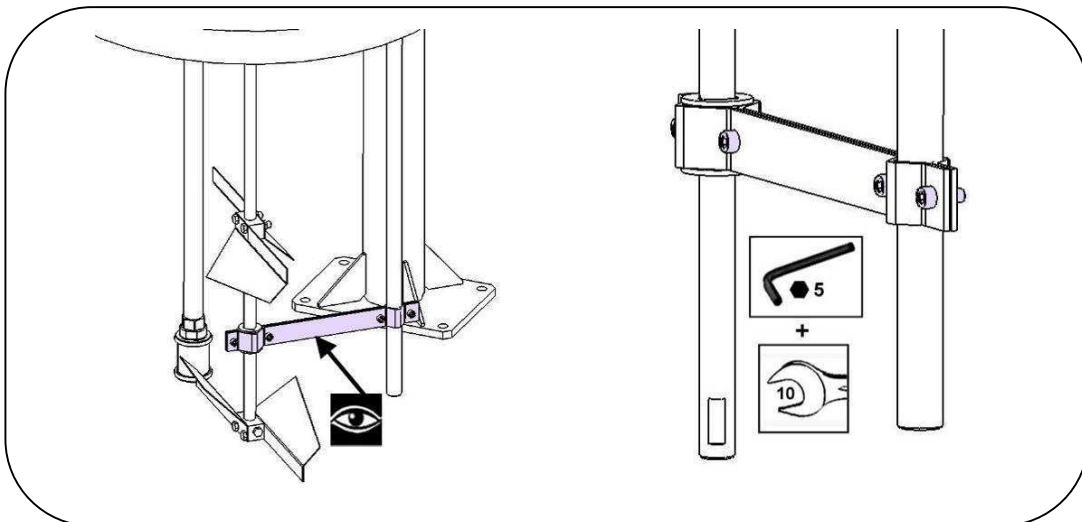
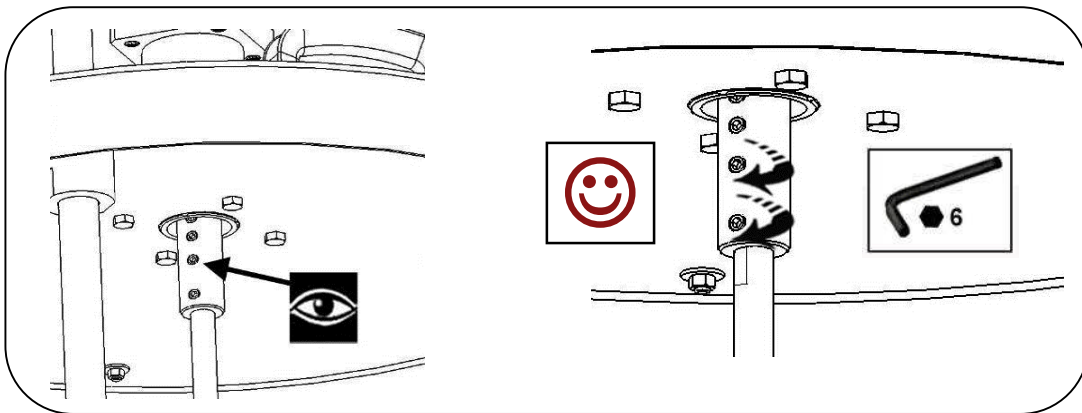
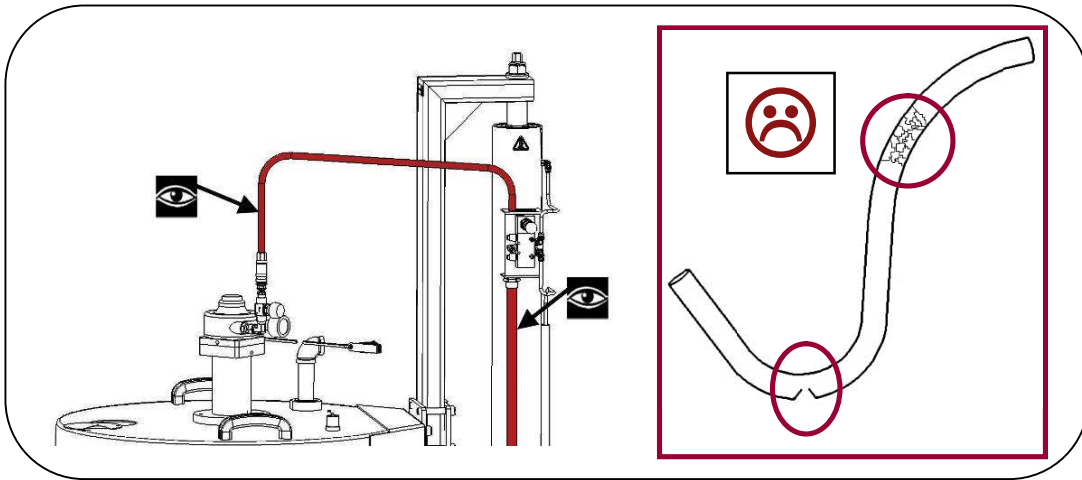

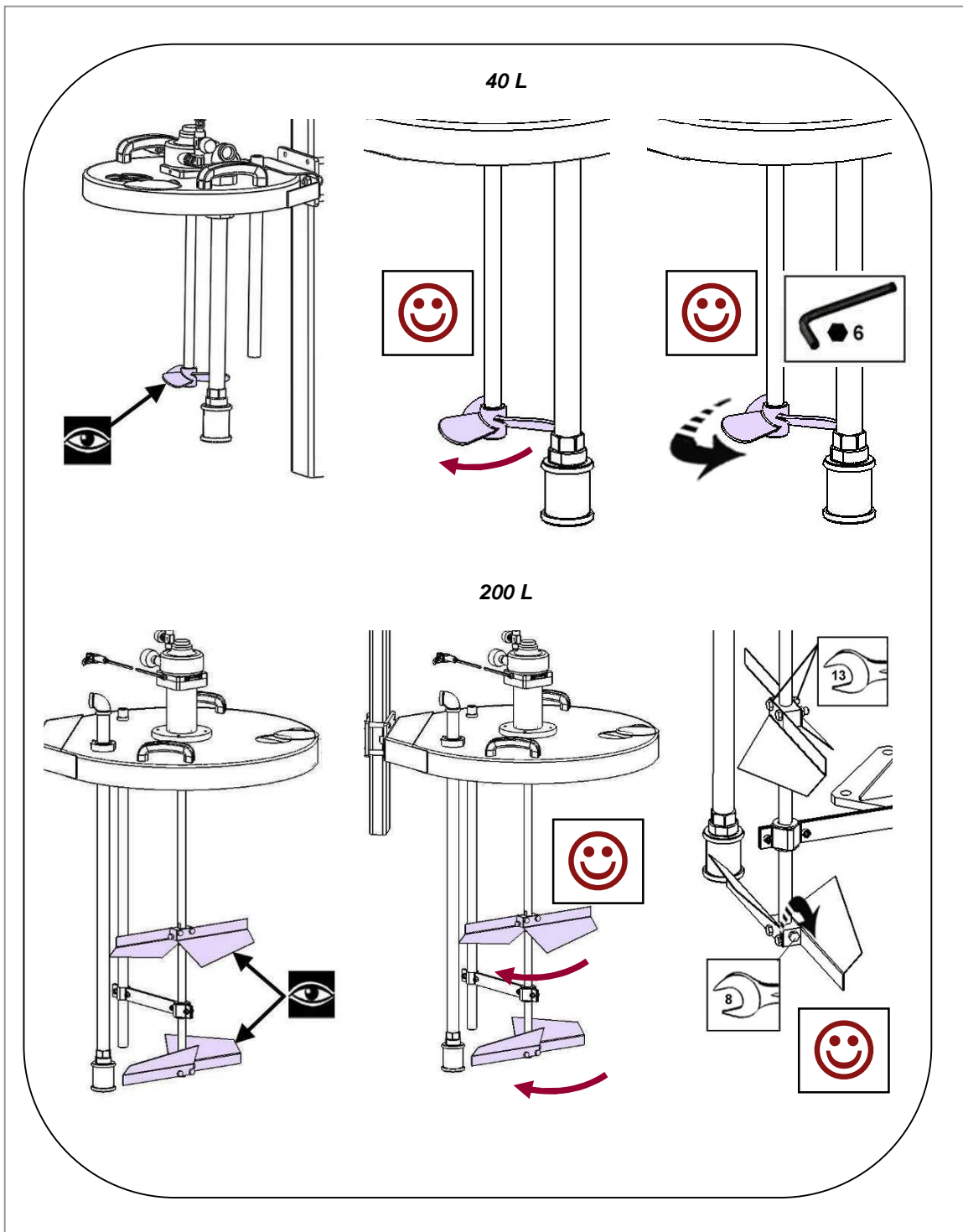

MENSUEL / MONTHLY SERVICE / MONATLICH / MENSUAL

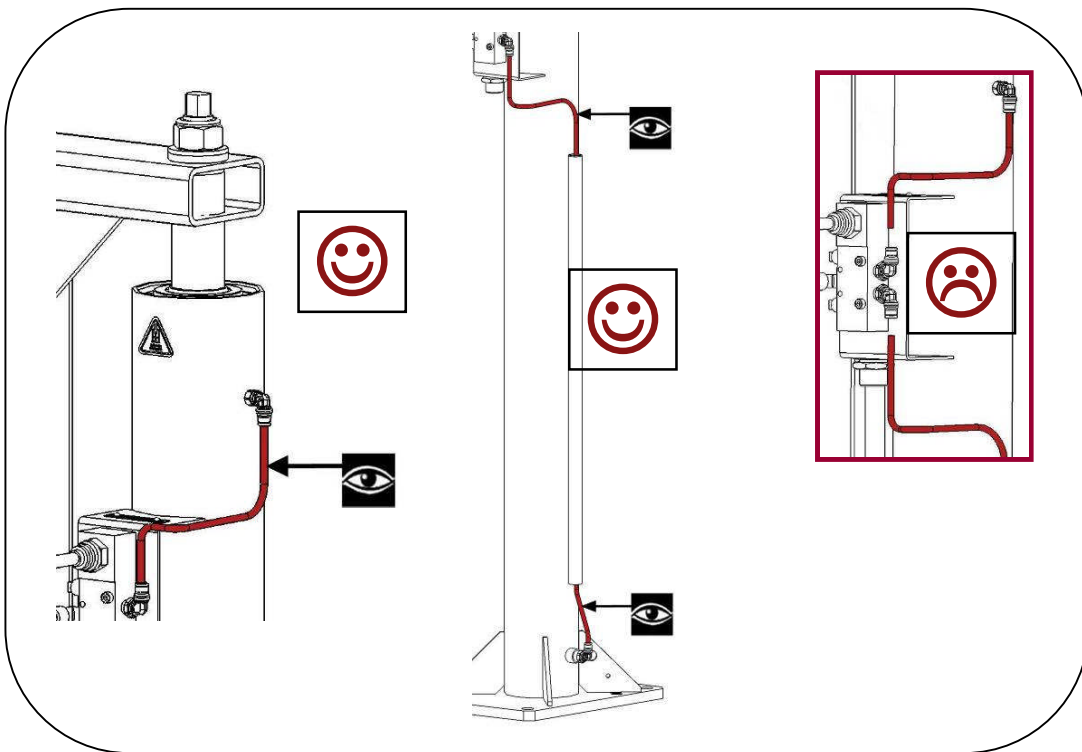
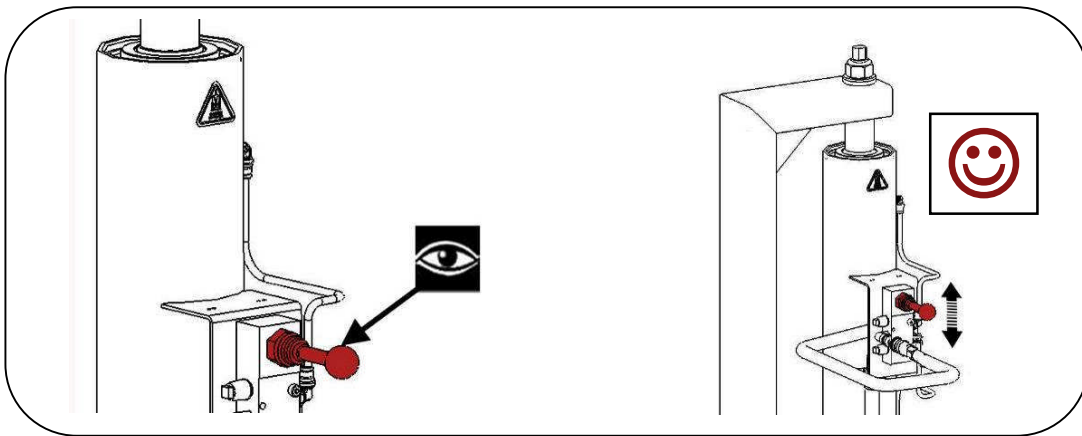
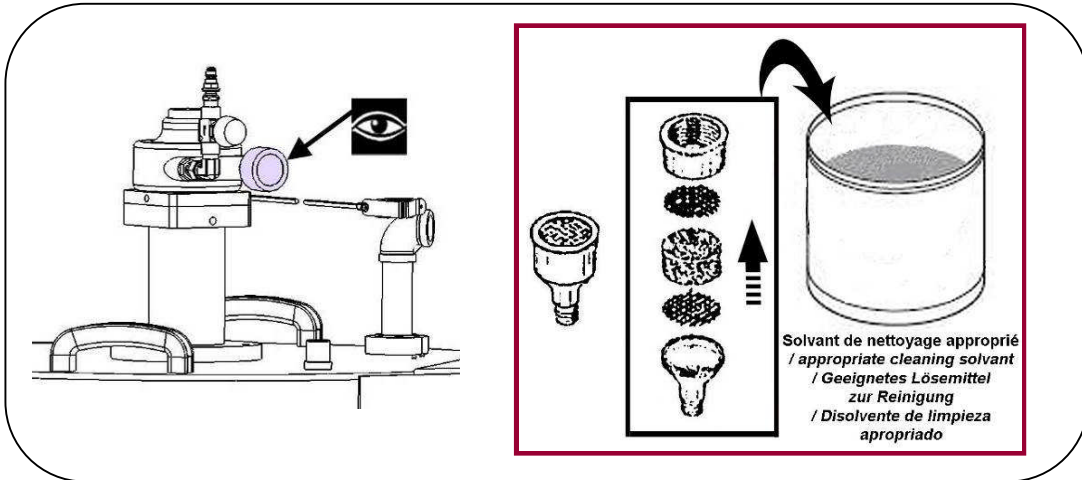

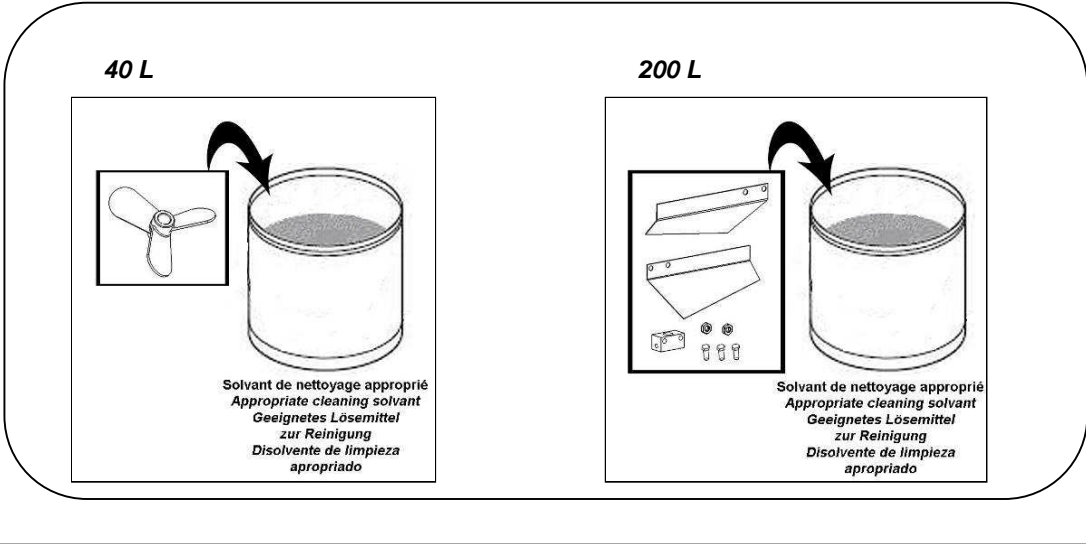
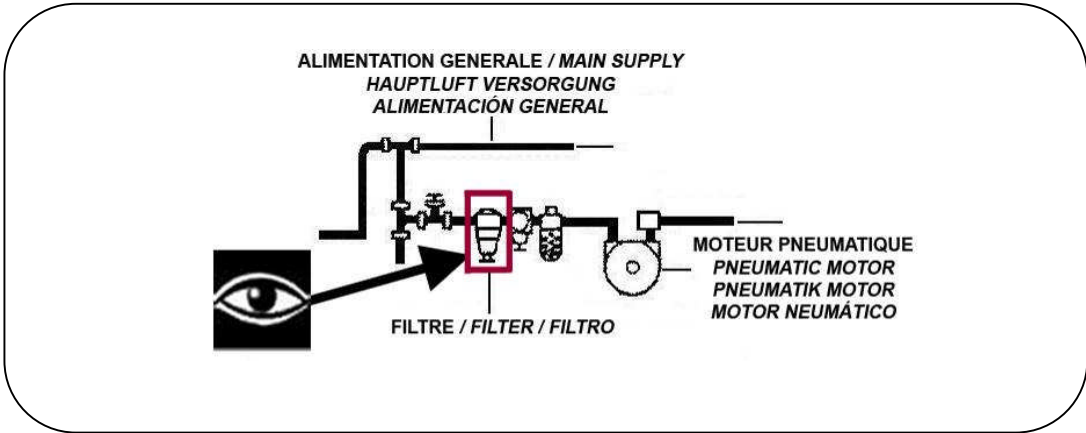

SEMESTRIEL / HALF YEARLY SERVICE / HALBJÄHRLICH / BIANUAL

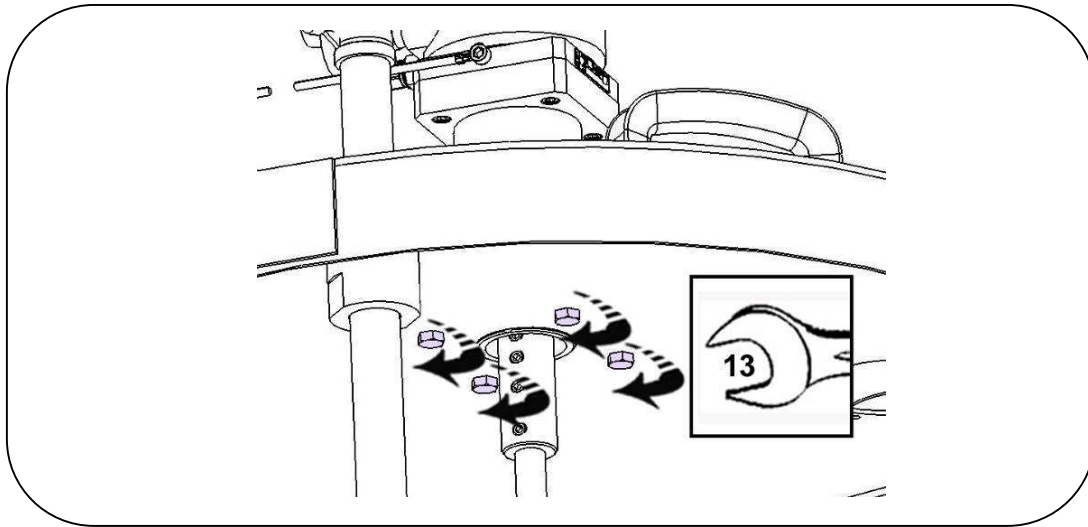
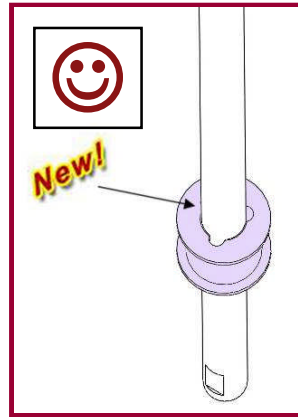
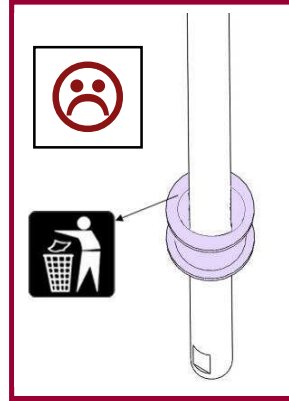
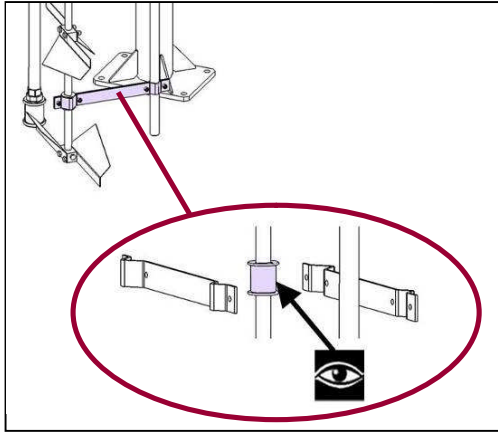

ANNUEL / YEARLY SERVICE / JÄHRLICH / ANUAL

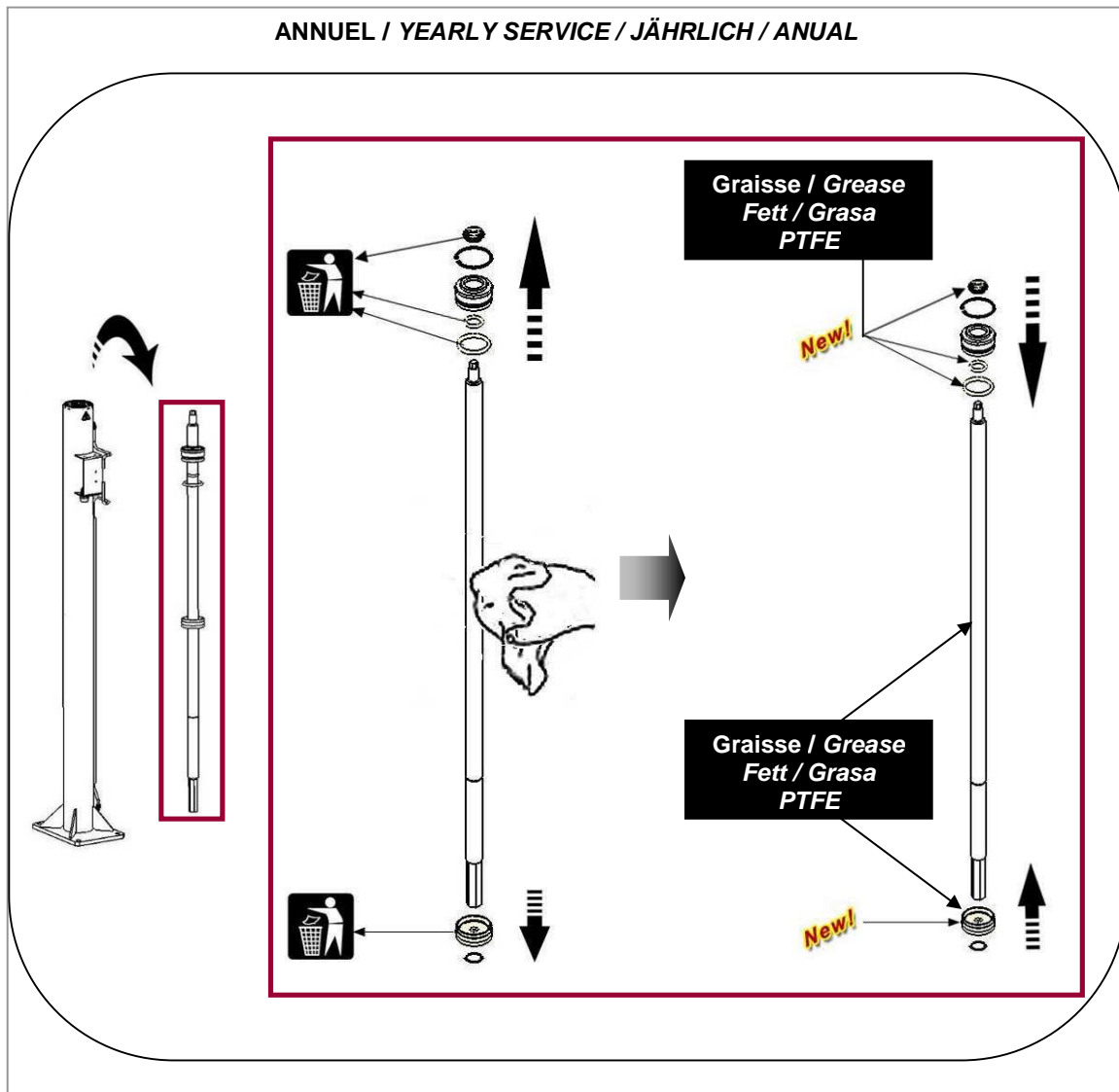

Nota : Les fréquences sont données à titre indicatif. Elles doivent être adaptées par le service d'entretien de l'utilisateur, pour chaque installation en fonction du produit, de la cadence et de la pression de travail.

Note : Frequencies are given as a guide. They must be followed by the maintenance service of the user for each installation according to the product, the working frequency and the working pressure.

Anmerkung: Die Häufigkeit der Kontrollen ist nur ein Vorschlag. Sie müssen die tatsächlich notwendigen Wartungsintervalle für jede Anlage selbst ermitteln. Sie sind abhängig von dem individuellen Einsatz, dem benutzten Material, dem Betriebsdruck und der täglichen Einsatzdauer.

NOTA : Las frecuencias se dan como dato orientativo. El servicio de mantenimiento del utilizador debe adaptarlas para cada utilización, en función del producto, del ritmo de trabajo, de la presión de trabajo.



GUIDE DE DEPANNAGE TROUBLESHOOTING GUIDE FEHLERSUCHE INCIDENCIAS DE FUNCIONAMIENTO

UNITE D'AGITATION / AGITATION UNIT RÜHRWERKE / UNIDAD DE AGITACIÓN 40 & 200 L / 10.6 & 52.8 US GAL CYCLIX II

NOTICE ORIGINALE
/ TRANSLATION FROM THE ORIGINAL MANUAL
/ ÜBERSETZUNG DER ORIGINAL BETRIEBSANLEITUNG
/ TRADUCCIÓN DEL LIBRO ORIGINAL

L'équipement est soumis à la directive ATEX et ne doit en aucun cas être modifié. Le non-respect de cette préconisation ne saurait engager notre responsabilité.

/ The equipment is manufactured under the ATEX agreement and should not be modified. KREMLIN REXSON will not be held responsible for any failure to comply with that instruction.

/ Diese Anlage hat die ATEX Zulassung, deswegen darf sie nie verändert werden. Bei Nichtbeachtung dieser Anordnung, können wir keine Verantwortung für eine einwandfreie, regelkonforme Funktion der Anlage übernehmen.

/ El equipo es de conformidad a la directiva ATEX y no debe ser modificada, en ningún caso. KREMLIN REXSON no se hace responsable de que esta preconización no sea respetada.

/ Des protecteurs (capot moteur, protecteur d'accouplement, carters,...) sont mis en place pour une utilisation sûre du matériel.

Le fabricant ne peut être tenu pour responsable en cas de dommages corporels ainsi que des pannes et / ou endommagement du matériel résultant de la destruction, de l'occultation ou du retrait total ou partiel des protecteurs.

/ Guards (motor cover, coupling shields, connectors,...) have been designed for a safe use of the equipment. The manufacturer will not be held responsible for bodily injury or failure and / or property damage due to destruction, the overshadowing or the partial or total removal of the guards

/ Schutzvorrichtungen an diesem Gerät, wie Motorhaube, Kupplungsschutz, Gehäuse, ggf. Erdungskabel, sowie weitere Vorrichtungen, wurden für eine sichere Benutzung dieses Gerätes entwickelt und angebracht. Der Hersteller lehnt jede Verantwortung für Körperschäden, Fehlfunktionen, Beschädigung der Geräte, und jegliche andere Fehler ab, die durch die ganze oder teilweise Entfernung, Modifikation oder unsachgemäße Handhabung der Schutzvorrichtungen oder anderen Geräteteilen entstehen.

/ Protectores (capó motor, protector de acoplamiento, cárteres,...) se colocan para una utilización segura del material. El fabricante no se hace responsable, en caso de daños personales, así como de las averías y / o daños del material, resultantes de la destrucción, la ocultación o la retirada total o parcial de los protectores.

**L'AGITATEUR NE DEMARRE PAS OU SA VITESSE EST TROP FAIBLE
 / THE AGITATOR DOES NOT START UP OR ITS SPEED IS TOO LOW
 / DAS RÜHRWERK LÄUFT NICHT AN ODER DIE GESCHWINDIGKEIT IST ZU GERING
 / EL AGITADOR NO ARRANCA O SU VELOCIDAD ESTÁ DEMASIADA BAJA**

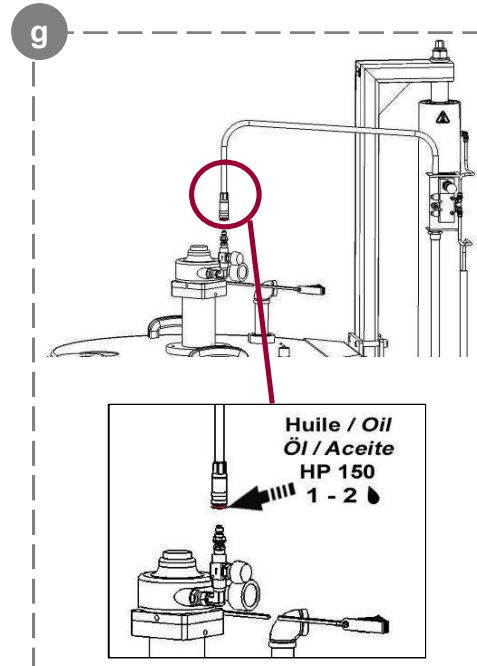
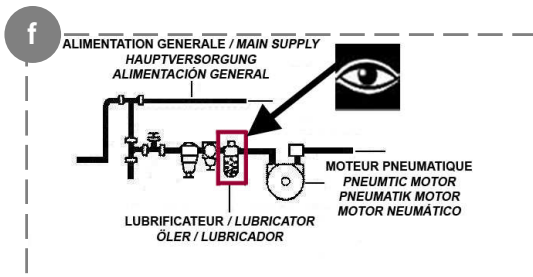
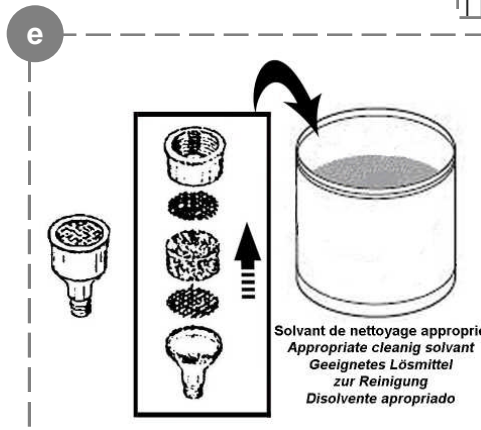
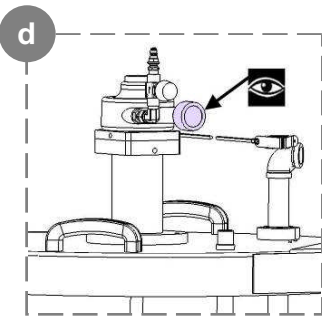
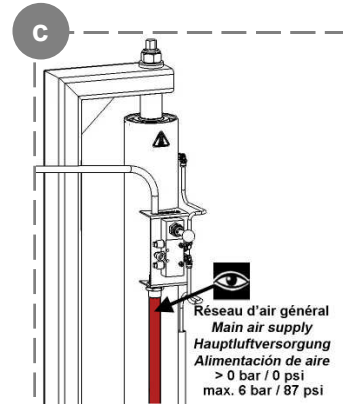
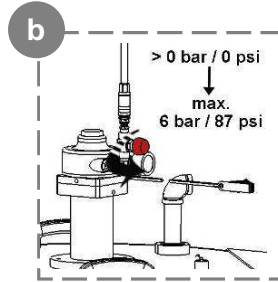
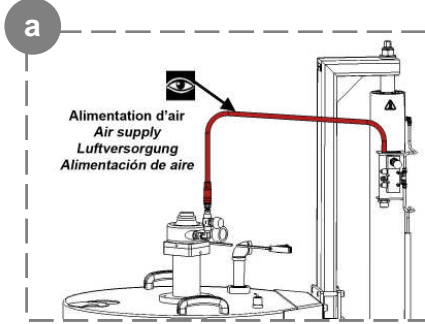

L'AGITATEUR DEMARRE MAIS RIEN NE SE PASSE
/ THE AGITATOR STARTS BUT NOTHING HAPPENS
/ DER LUFTMOTOR STARTET, ABER NICHTS PASSIERT
/ EL AGITADOR ARRANCA PERO NADA PASA

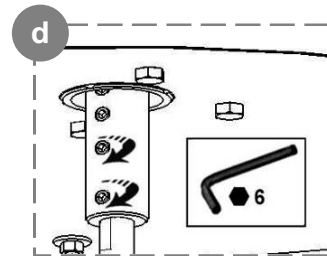
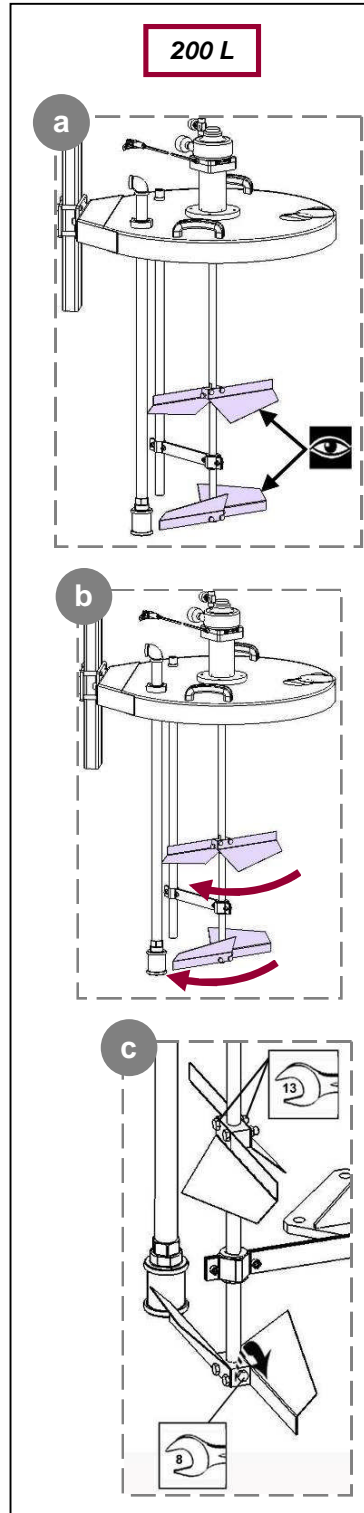
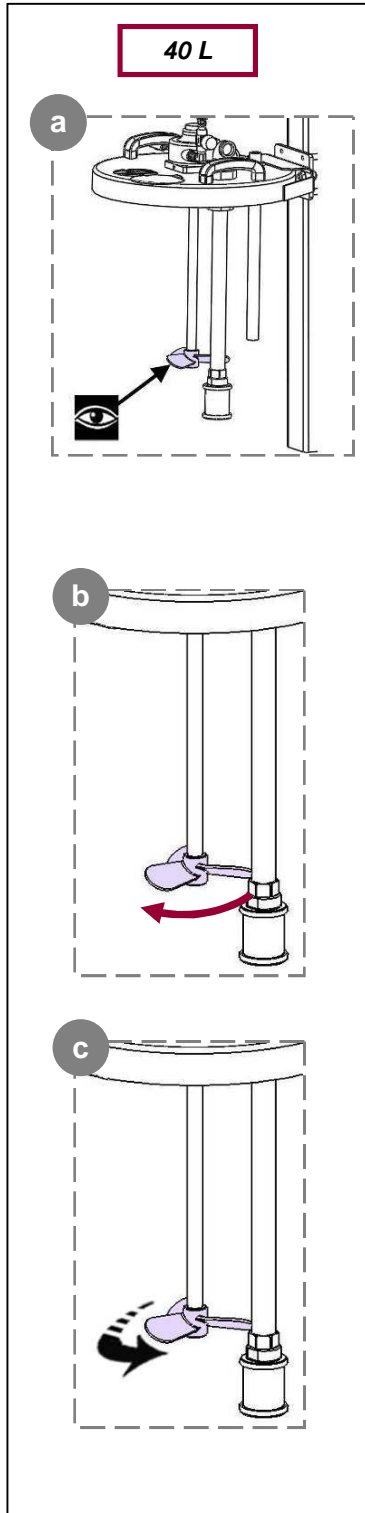

SURCHAUFFE / OVERHEATING / ÜBERHITZUNG / RECALENTAMIENTO

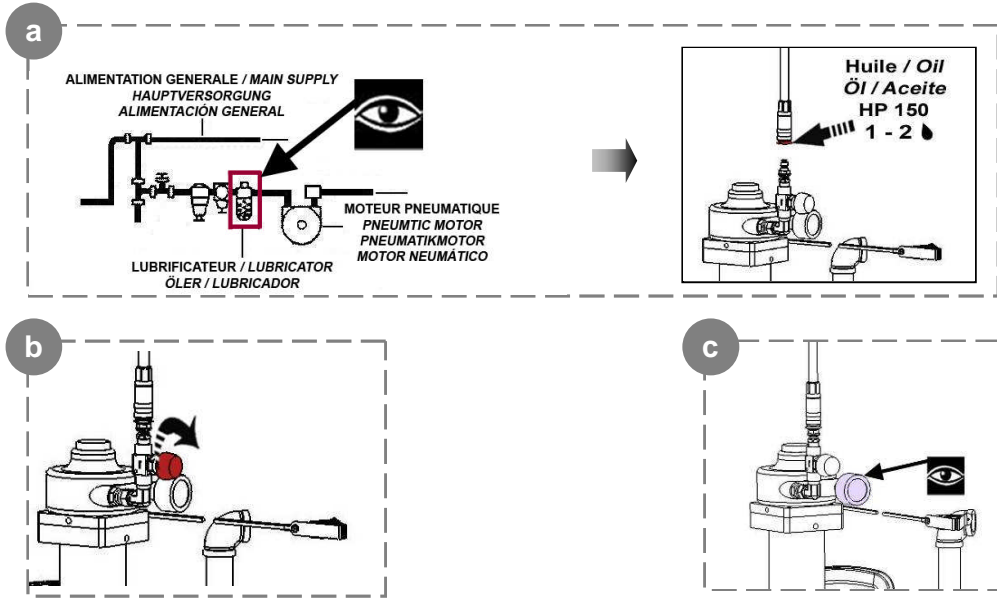

PRESENCE DE VIBRATIONS / VIBRATIONS / VIBRATIONEN / PRESENCIA DE VIBRACIÓN

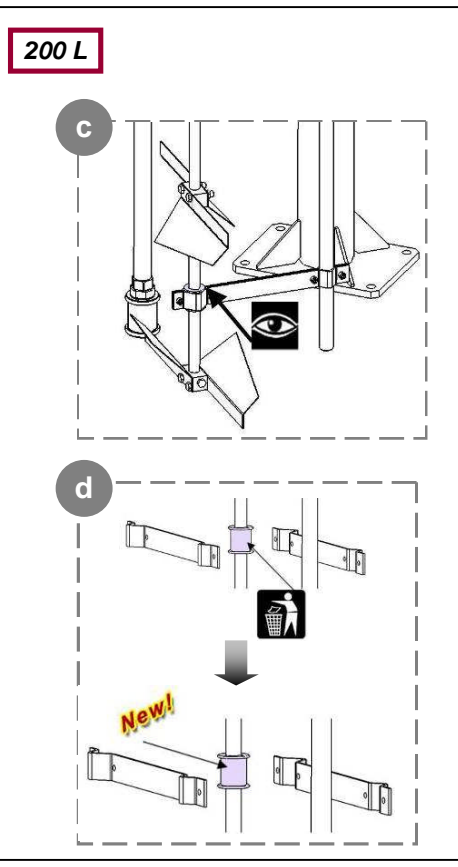
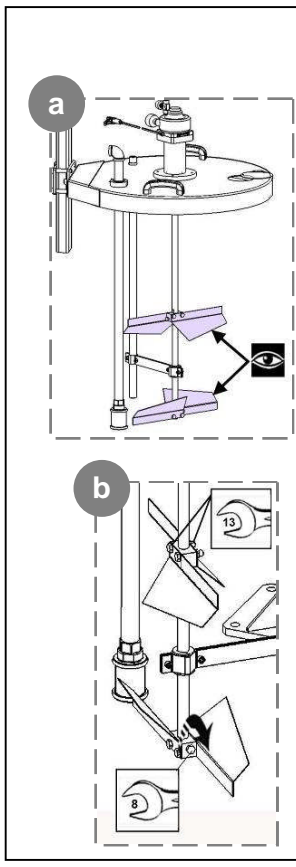
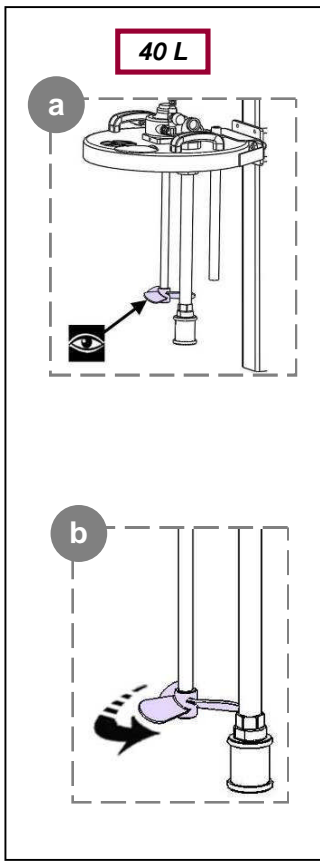

**L'ELEVATEUR NE MONTE PLUS / THE SINGLE-POST RAM DOES NOT GO UP ANY MORE
/ DER DECKELHEBER FÄHRT NICHT NACH OBEN / EL ELEVADOR NO SUBE MÁS**

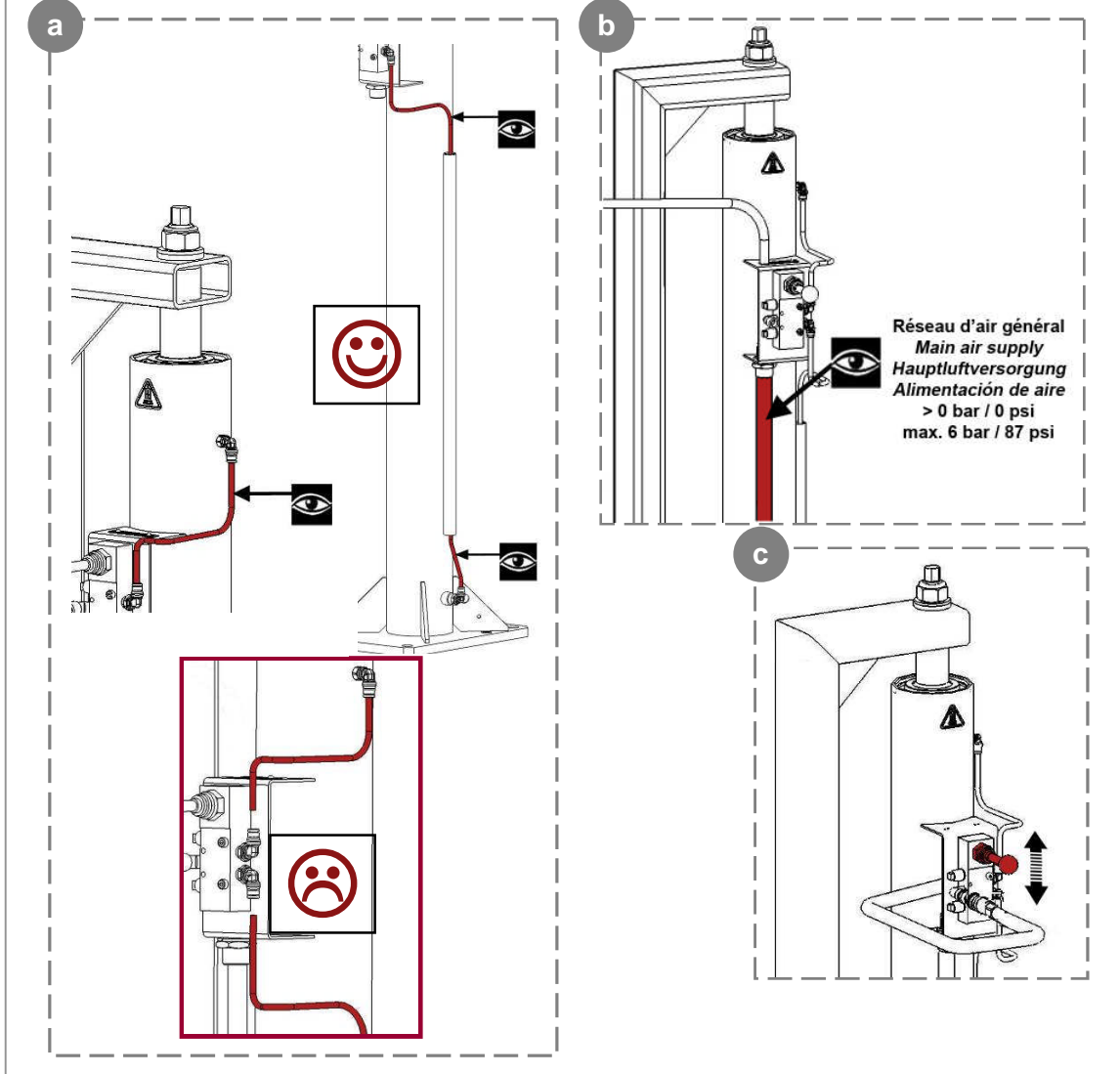

**PRESENCE DE GOUTELETTES D'HUILE A LA SORTIE DU SILENCIEUX
/ PRESENCE OF OIL DROPS ON THE OUTLET OF THE MUFFLER
/ ÖLTROPFEN AM AUSGANG DES SCHALLDÄMPFERS / PRESENCIA DE GOTITAS DE
ACEITE A LA SALIDA DEL SILENCIADOR**

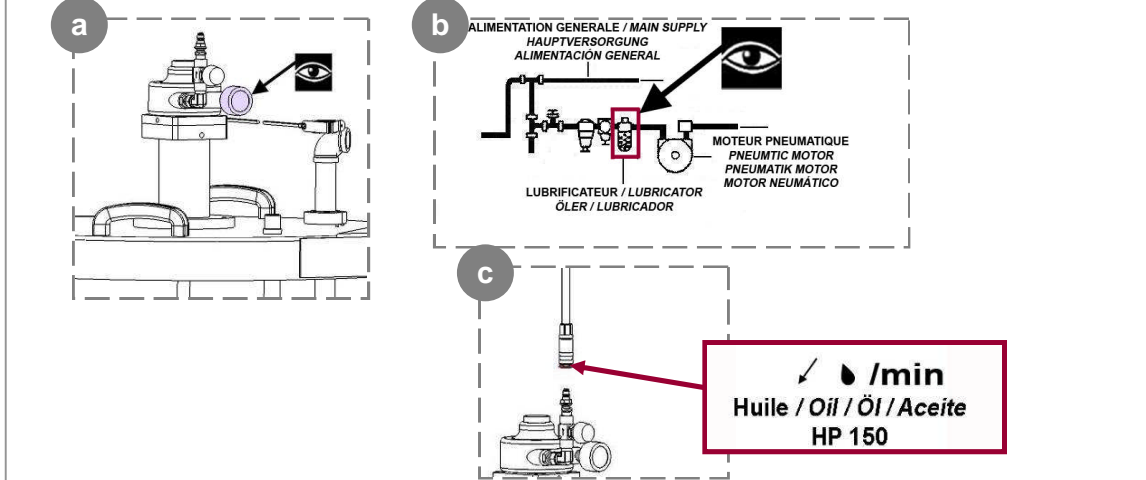

DEFAUT D'ASPIRATION / SUCTION FAULT / ANSAUGFEHLER / DEFECTO DE ASPIRACIÓN

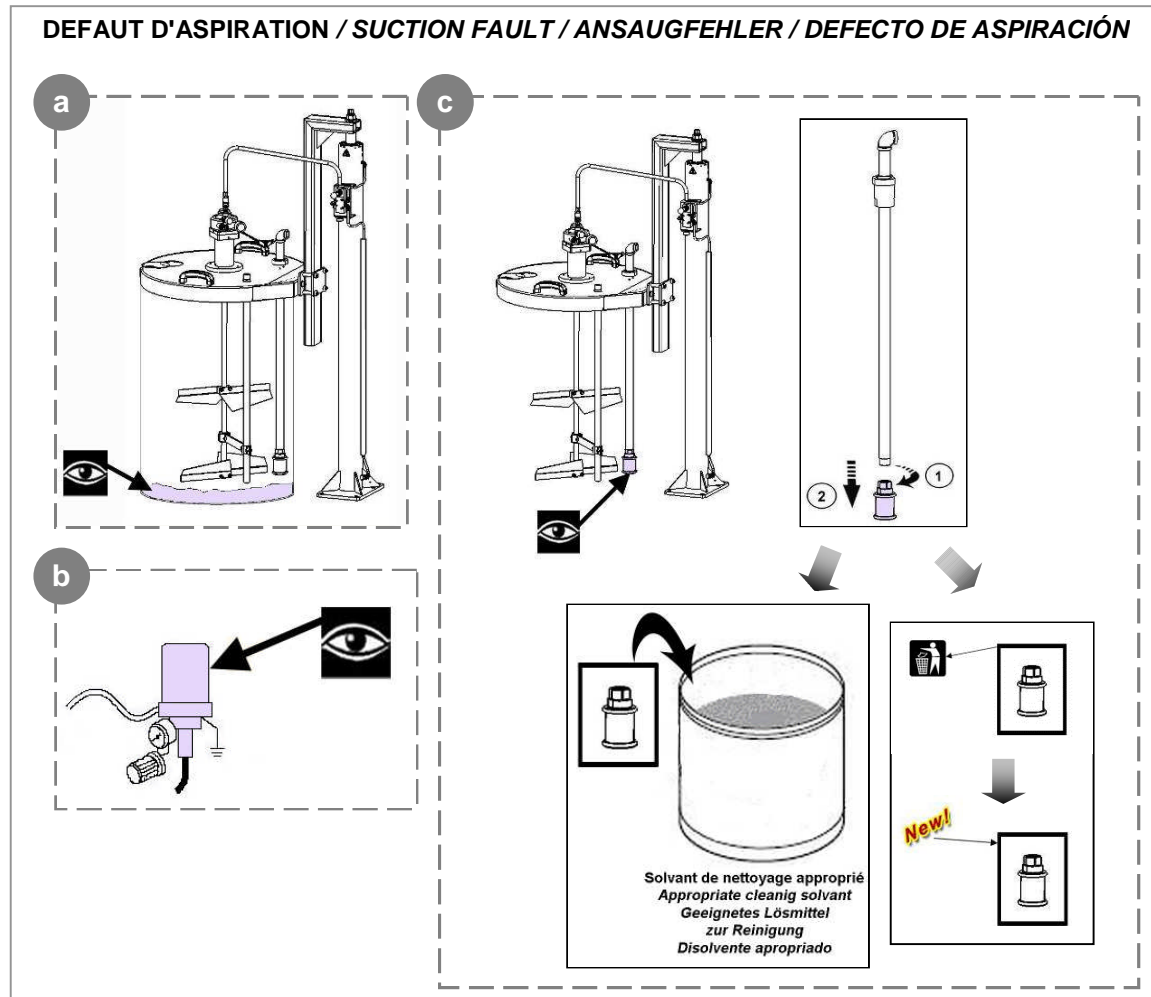

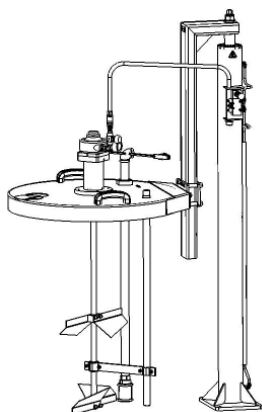
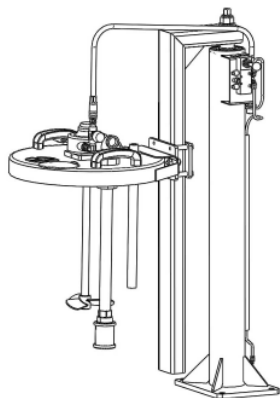

AGITATION UNIT
40 L / 10.6 US gal
&
200 L / 52.8 US gal
CYCLIX II

OPERATING

TRANSLATION FROM THE ORIGINAL MANUAL

IMPORTANT : Before assembly and start-up, please read and clearly understand all the documents relating to this equipment (professional use only).

THE PICTURES AND DRAWINGS ARE NON CONTRACTUAL. WE RESERVE THE RIGHT TO MAKE CHANGES WITHOUT PRIOR NOTICE.

KREMLIN - REXSON

150, avenue de Stalingrad

93 245 - STAINS CEDEX - France

☎ : 33 (0)1 49 40 25 25 Fax : 33 (0)1 48 26 07 16

www.kremlin-rexson.com

1. ADJUSTMENT

Before operating the equipment, check that the agitator is correctly grounded on the cover and that ground is carried out.



A lubrication of the agitator is necessary.
Supply air must be filtered and lubricated.
The maximum air supply pressure is 6 bar /87 psi.
Install a filter and a lubricator on the agitator air supply.

Adjustment of the lubricator

Agitation unit	Nb of drops / mn (constant operating)
40 L / 10.6 US gal	1-2
200 L / 52.8 US gal	

Recommended oil : HP 150 oil (refer to spare parts' list - option).

A lack of lubrication can lead to serious damage of the agitator motor.

The filter / lubricator must be installed above the motor (maximum distance from the pneumatic motor : 0.5 m / 1.6 ft) (Refer to drawing).

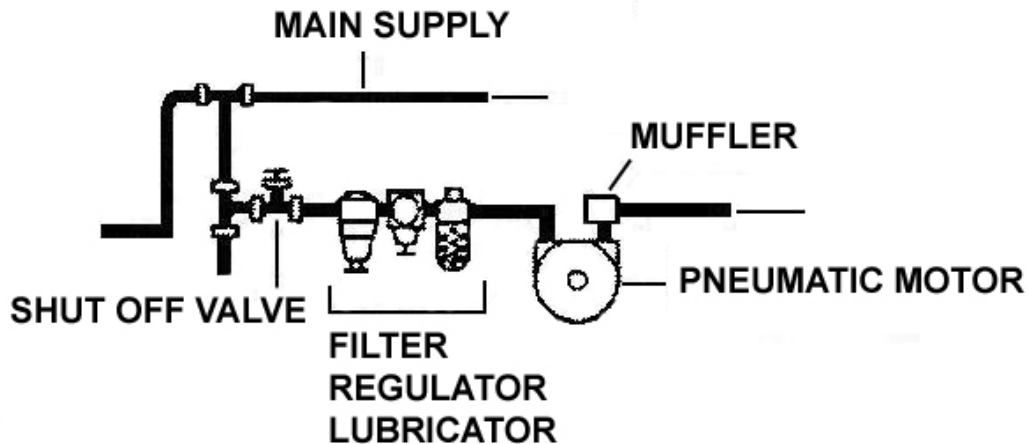

The hoses fitted with a quick release fitting can be connected to the elevator or the agitator depending upon the working stage :

- ⇒ *When you have to rise or lower the cover, the air hose must be connected to the elevator; there is no air on the motor of the agitator.*
- ⇒ *When the air hose is connected on the motor of the agitator, and its rotating; you cannot rise or lower the cover.*



The maximum air supply pressure is 6 bar /87 psi. Do not run the agitator at high speed. Do not run the equipment with no load. It can lead to a deterioration of the paint, vibrations and an early wear of the parts.

▪ REPLACEMENT OF THE DRUM

**Guards (motor cover, coupling shields, connectors,...) have been designed for a safe use of the equipment.
The manufacturer will not be held responsible for bodily injury or failure and / or damage to property due to negligence or the partial or total removal of the guards.**



Keep a sufficient gap between the bottom of the drum and the blades of the agitator to avoid frictions and sparks.

Close the air supply by unscrewing the knob of the air regulator. The motor of the agitator stops.

Disconnect the air hose that supplies the agitator motor.

Connect the hose to the air inlet of the pneumatic control.

Move the distributor lever upwards to put the whole in the up position.

Take off the empty drum.

Check that the tightening of the motor rod is correct.

Place the new drum under the cover of the single-post ram.

Make the whole get down holding the distributor lever downwards (Take care to center the drum under the cover in order not to damage the elements).

Bring into contact the cover with the drum.

Disconnect the quick release fitting of the elevator and connect it on the agitator air inlet.

Open the air supply by screwing the knob of the air regulator. The motor of the agitator starts up.

2. FIRST START-UP

Before operating the equipment, lubricate the pneumatic motor adding 4 or 5 oil drops on the quick release fitting of the air supply hose.

Check that the agitator is correctly grounded on the cover and that ground is carried out.

Check that moving parts are not in contact with the drum to avoid sparks.

Check the connection to the air supply.

Adjust the air regulator by controlling the rotation speed of the agitator.

Close the hatch.

The agitation unit is ready for use.



Do not operate the agitator outside of a drum.

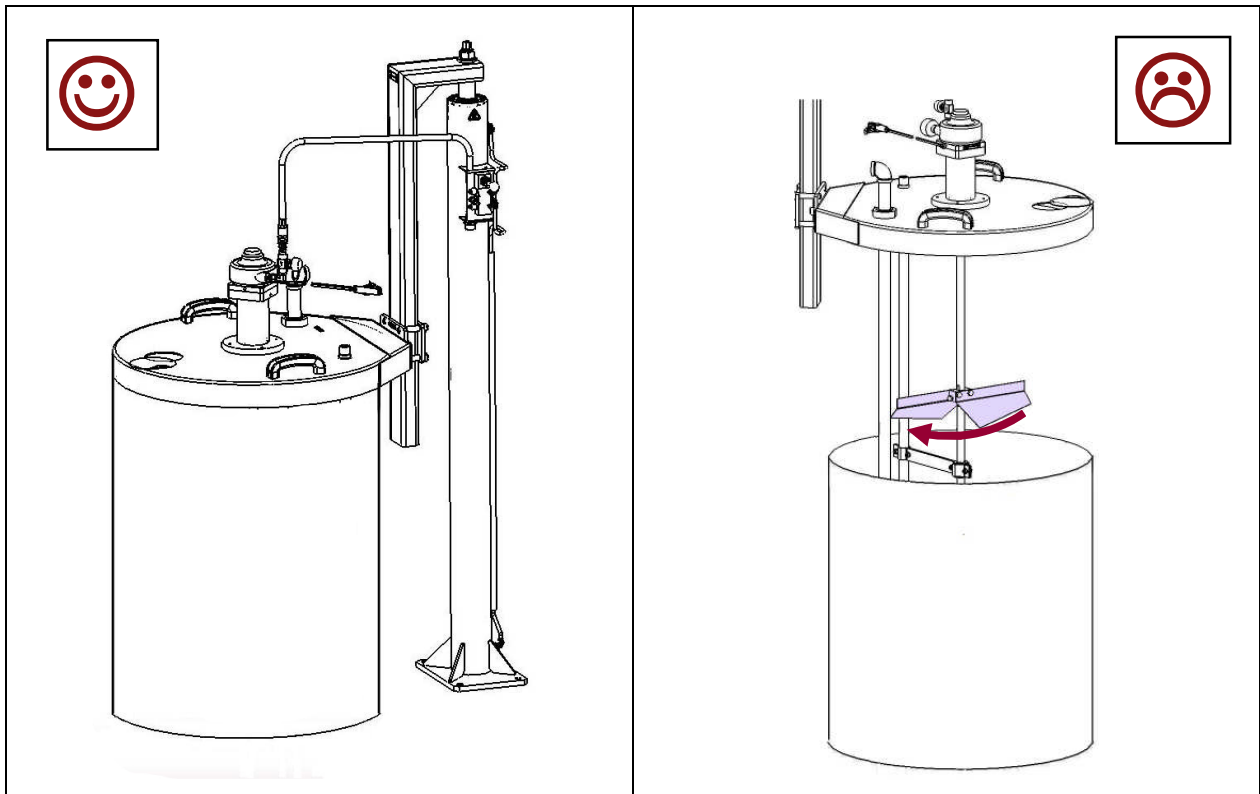

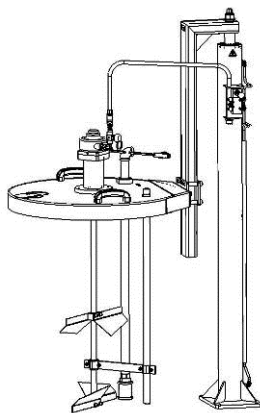
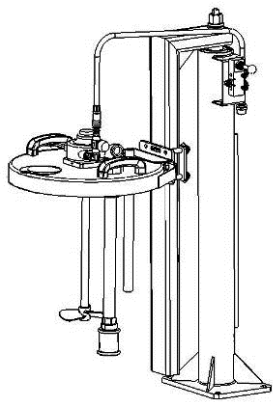

**AGITATION UNITS
40 L / 10.6 US gal
&
200 L / 52.8 US gal
CYCLIX II**

TECHNICAL FEATURES

TRANSLATION FROM THE ORIGINAL MANUAL

IMPORTANT : Before assembly and start-up, please read and clearly understand all the documents relating to this equipment (professional use only).

THE PICTURES AND DRAWINGS ARE NON CONTRACTUAL. WE RESERVE THE RIGHT TO MAKE CHANGES WITHOUT PRIOR NOTICE.

KREMLIN - REXSON

150, avenue de Stalingrad

93 245 - STAINS CEDEX – France

☎ : 33 (0)1 49 40 25 25 Fax : 33 (0)1 48 26 07 16

www.kremlin-rexson.com

1. DESCRIPTION

This equipment is designed to be installed on drums (40 o 200 liters) . They are designed to ensure good homogenization and to agitate liquids or semi liquid products in the drum.

Each assembly consists of a single-post ram, a cover fitted with an agitator, a suction rod and a return rod.

The elevator makes it easy for the installation and replacement of the drum.

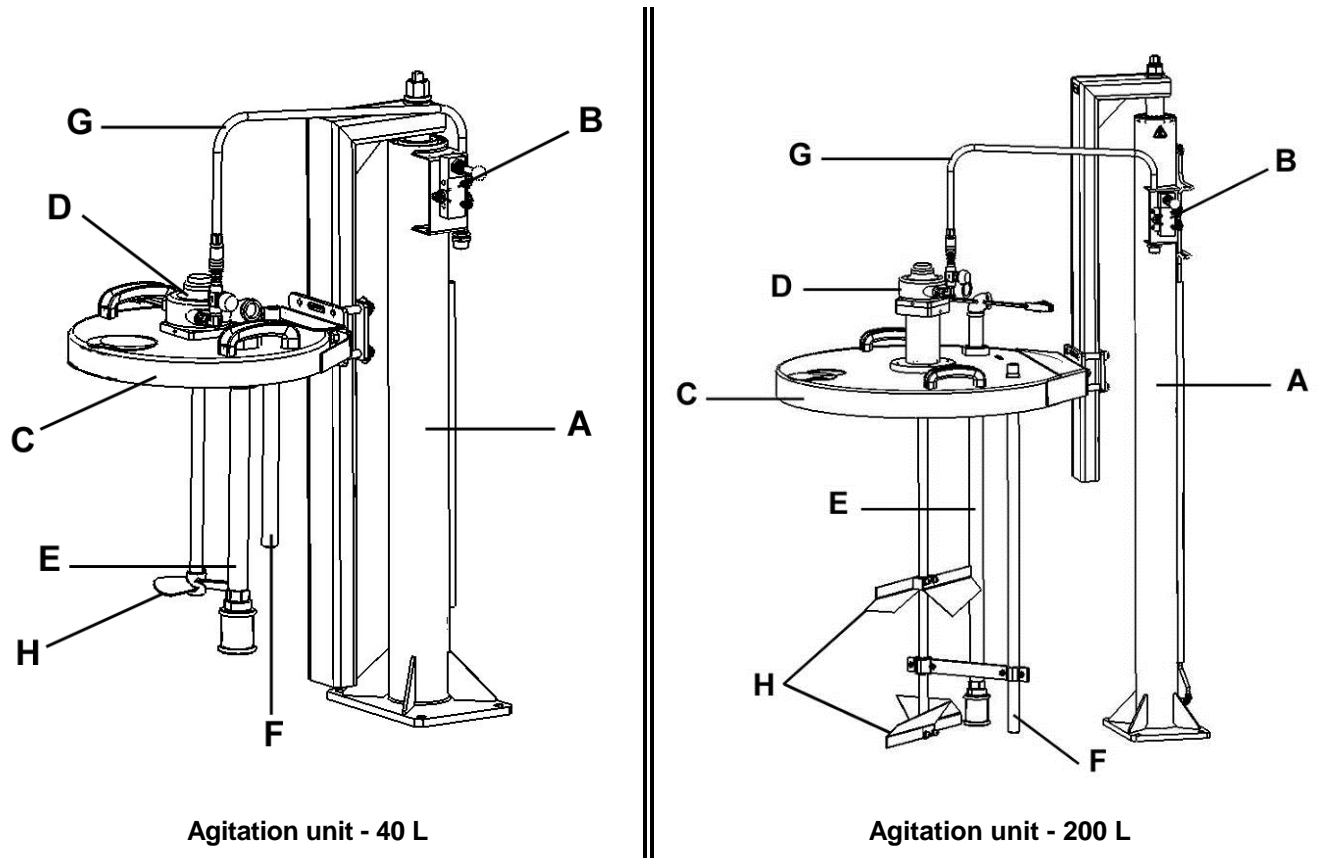

CAPTIONS :

- A : Single-post ram
- B : Single-post ram control
- C : Cover
- D : Agitator
- E : Suction rod
- F : Return rod
- G : Air hose with quick release fitting
- H : Propeller blades

2. TECHNICAL FEATURES

▪ DIMENSIONS

DRUM – 40 L

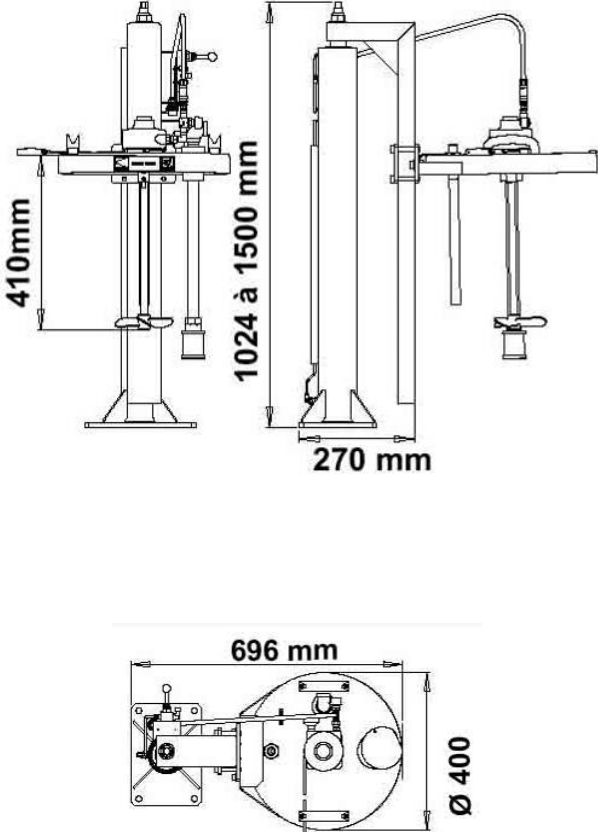
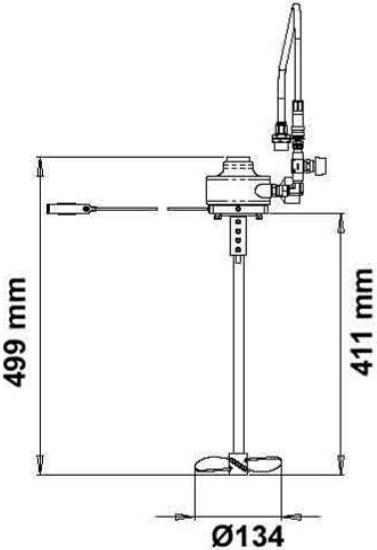
<p><u>Agitation unit</u></p> <p>Single-post ram stroke : 450 mm</p> <p>Weight : 43 kg</p>	
<p><u>Agitator</u></p>	

DRUM – 200 L

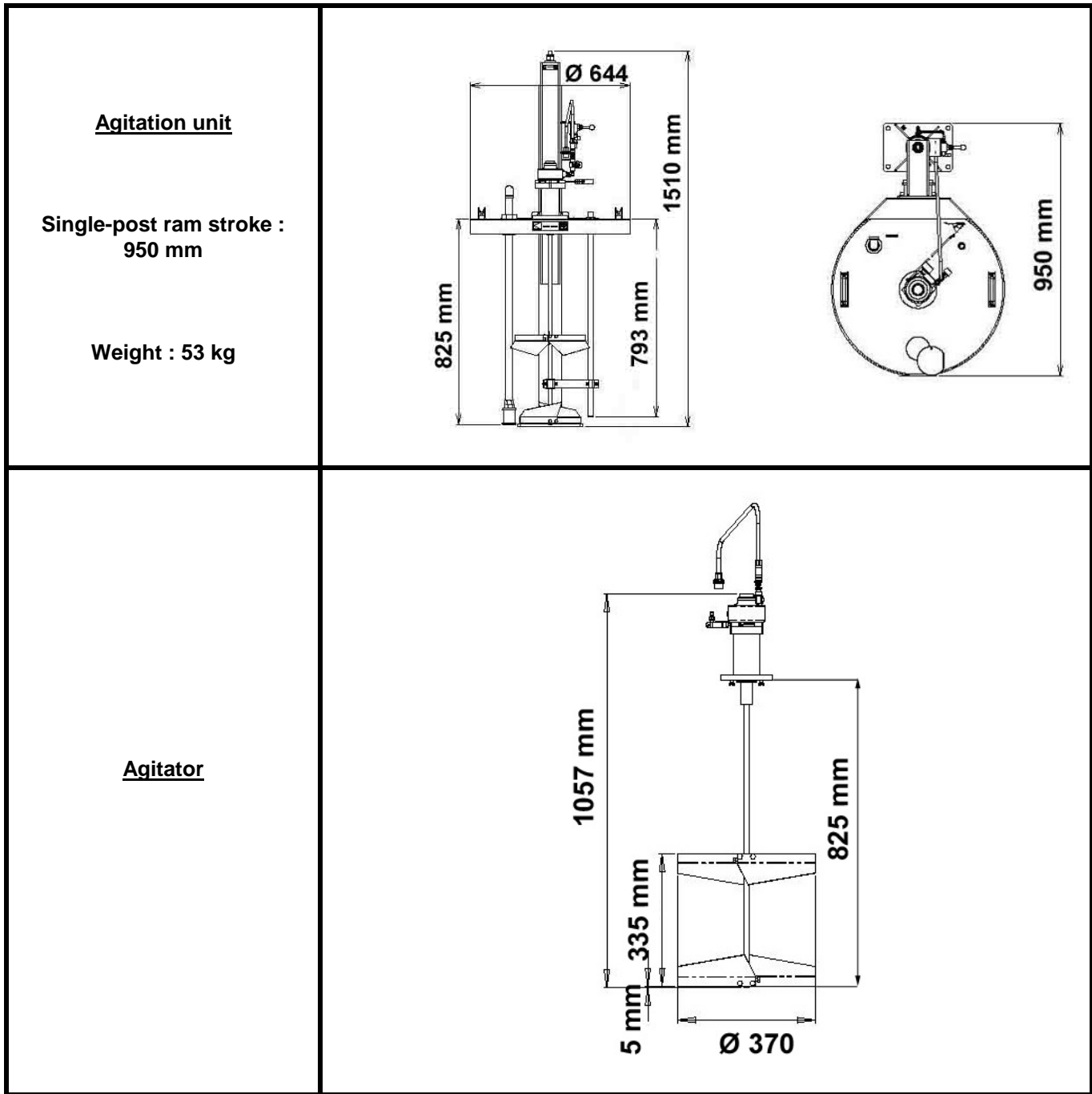

▪ **NOISE LEVEL**

Noise level : > 85 dB(A)

▪ **TECHNICAL FEATURES OF THE MOTORS**

Version	#	Weight (Kg)	Max. power (kW)	Max. speed of the propellers (tr/min)	Stop torque (N.m)*	Torque 100tr/min (N.m)*	Air consumption (l/s)
40 L	146 020 400	3,2	550	3000	2,1	2,2	12
200 L	146 020 450	8,6	550	187,5	37	34	12

*Torque given for an air equal to 6 bar / 87 psi

▪ **OPERATING CONDITIONS**

Ambient range temperature : from -20 to +40° C

Maximum fluid temperature : 60° C / 140° F



The maximum air supply pressure is 6 bar / 87 psi. Do not run the agitator at high speed. Do not run the equipment with no load. It can lead to a deterioration of the paint, vibrations and an early wear of the parts.



Keep away hands and fingers from the blades of the agitator. Do not operate the blades out of the drum. Serious injuries can occur (cuts).



Keep a sufficient gap between the bottom of the drum and the blades of the agitator to avoid frictions and sparks.



The equipment is designed for a set number of propellers (1 propeller for the 40L version, 2 propellers for the 200L version).
Do not install more propellers than provided.

CURVES OF PERFORMANCES

The following curves indicate the ratio of "torques / powers / rotation speed and air consumption" for a regular air supply pressure.

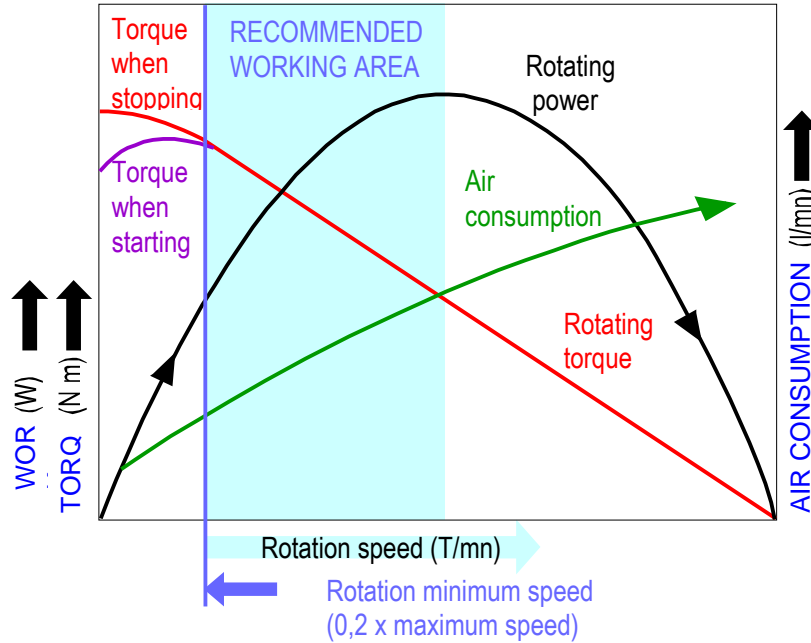

ROTATION

We advise you not to exceed the maximum speed indicated to ensure a longer motor life time. A speed lower than the minimum indicated will not give constant results.

TORQUE AND ROTATING SPEED

The number of turns decreases when the torque increases (torque and rotation are inversely proportional).

POWER

You will get maximum power from the motor running at intermediate speeds (between minimum and maximum), It is the most economical way to use the agitator.

AIR CONSUMPTION

Is proportional to the effort required by the motor.
For your information : 1MPa = 10 bar / 145 psi

■ AIR CONSUMPTION OF THE MOTORS

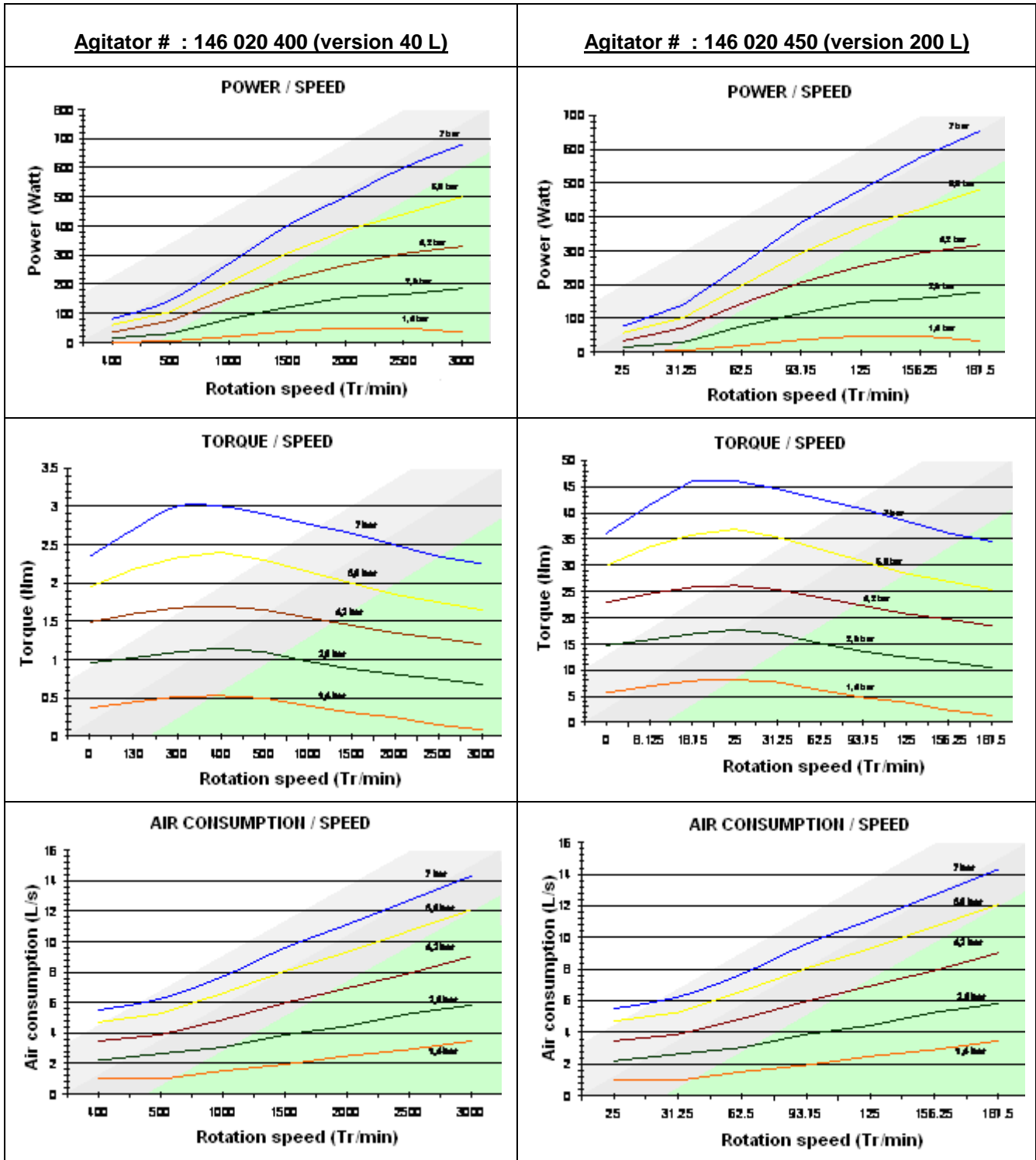

3. INSTALLATION

The agitation units are designed to be installed in a spray booth.

▪ **DESCRIPTION OF THE LABEL MARKING OF THE SINGLE-POST RAM**

Marking according to the ATEX directive

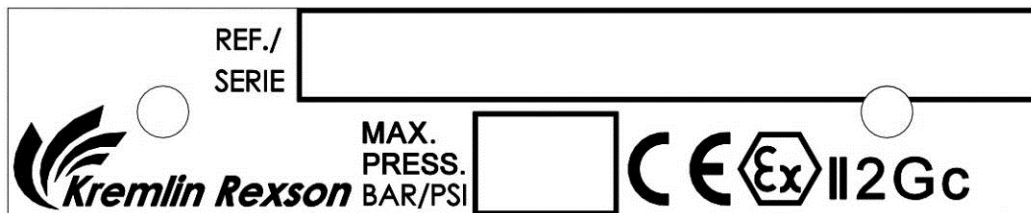

REXSON	Name of the manufacturer
CE	European conformity
II 2 G c	<p>II : group II 2 : class 2 Surface equipment meant to an area in which there is an explosive atmosphere with an excessive mixture of air, gases and vapours, which can occasionally build up during normal operation. G : gas c : Protection by constructional safety</p>
REF.	Part number of the unit
Serie / Serial	Number given by KREMLIN REXSON. The two first numbers indicate the manufacturing year.
MAX. PRES. (BAR/PSI)	Maximum pressure

Operating maximum temperature rise : $\Delta T \leq 5^\circ \text{C}$

▪ **DESCRIPTION OF THE LABEL MARKING OF THE AGITATOR MOTOR**

Marking according to the ATEX directive



REXSON	Name of the manufacturer
CE	European conformity
II 2 G c T5	<p>II : group II 2 : class 2 Surface equipment meant to an area in which there is an explosive atmosphere with an excessive mixture of air, gases and vapours, which can occasionally build up during normal operation. G : gas c : Protection by constructional safety T5 : Surface maximum temperature : $100^\circ \text{C} / 212^\circ \text{F}$</p>
REF.	Part number of the unit
Serie / Serial	Number given by KREMLIN REXSON. The two first numbers indicate the manufacturing year.
MAX. PRES. (BAR/PSI)	Maximum pressure

■ INSTALLATION DIAGRAM

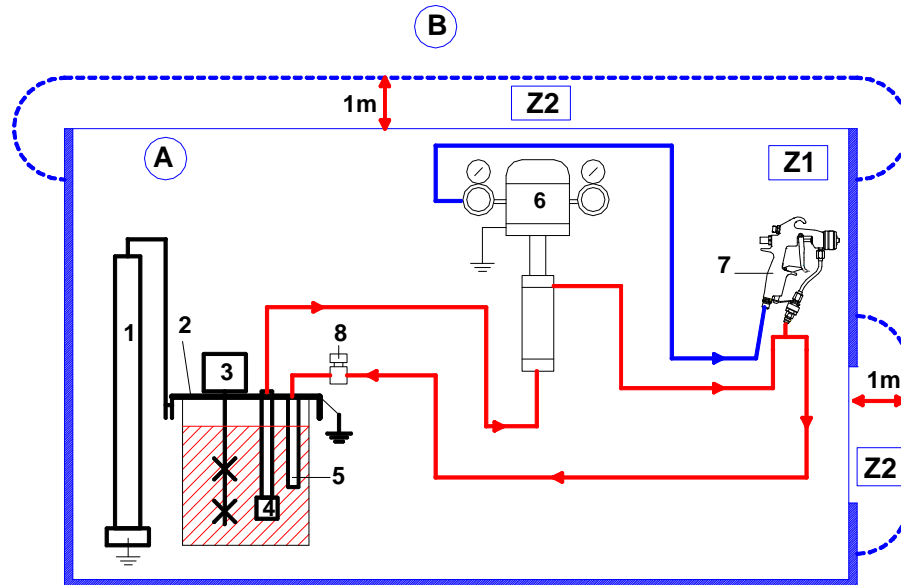

A	Explosive area Area 1 (Z1) or area 2 (Z2) : spray booth
B	Non explosive area
1	Elevator
2	Cover with earth cable
3	Agitator

4	Suction rod
5	Return rod
6	Pump (*)
7	Gun (*)
8	Circulating valve or back pressure regulator (*)

* not provided



The 1 m / 39.37" distance indicated in these diagrams is given for information purposes only and hold harmless to KREMLIN REXSON. The user is responsible for the extraction and conditioning of the painting area where the equipment is used, for working conditions conditions (refer to EN 60079-10 standard). The 1 m / 39.37" distance may be modified if trials carried out by the user deem this necessary.

4. CONNECTION

▪ GROUNDING



The motor is fitted with an earth cable. Connect the other end to a safe earth.

The foot of the elevator is fitted with a threaded rod. You can connect it to a safe ground.

▪ CONNECTION TO THE COMPRESSED AIR SUPPLY



Install a filter and a lubricator on the air supply of the agitator.
To ensure a correct operating and an optimum working life of the agitator, the supply air must be clean (without water), filtered and lubricated.

➡ **Install an FRL on the air supply of the agitator.**

Air fitting 1/4" G

Level of filtration required : 5 µm

Connect the installation to the compressed air network (maximum 6 bar / 87 psi).

Adjust the lubricator to get a flow of one drop / minute when high speed or constant operating.

Note :

The air supply to the agitator is via a hose fitted with a quick release fitting that can be connected to the elevator on motor according to the working stage.

⇒ When you have to rise or lower the cover, the air hose must be connected to the elevator; there is no air on the motor of the agitator.

⇒ When the air hose is connected to the agitator motor and is in operation, you cannot rise or flower the cover.

▪ FLUID CONNECTION

Suction rod	Elbow, model F 3/4 " G
Return rod	Male 1/2 "

Démontage / Remontage
Disassembly / Reassembly

Kit de transformation TONSON à GAST
Transformation kit (TONSON → GAST)

Pour fût de 40 litres - For drum, model 10.6 US gal
Pour fût de 200 litres - For drum, model 52.8 US gal

L'équipement est soumis à la directive ATEX et ne doit en aucun cas être modifié. Le non-respect de cette préconisation ne saurait engager notre responsabilité.

The equipment is manufactured under the ATEX agreement and can not be modified. KREMLIN REXSON will not be held responsible for any failure to comply with that instruction.

Des protecteurs (capot moteur, protecteur d'accouplement, carter, ...) sont mis en place pour une utilisation sûre du matériel.

Le fabricant ne peut être tenu pour responsable en cas de dommages corporels ainsi que des pannes et/ou endommagement du matériel résultant de la destruction, de l'occultation ou du retrait total ou partiel des protecteurs.

Guards (motor cover, coupling shields, connectors, ...) have been designed for a safe use of the equipment.

The manufacturer will not be held responsible for bodily injury or failure and/or property damage due to destruction, the overshadowing or the partial or total removal of the guards.

Pour fût de 40 litres

For drums, model 10.6 US gal

154 261 995

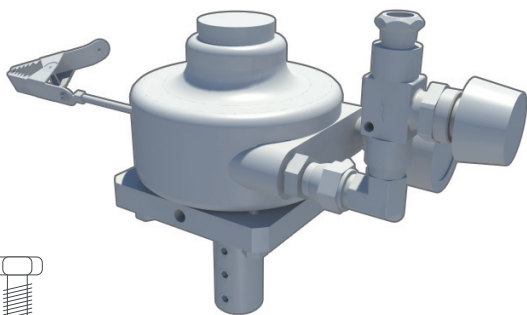

Pour monter le kit vous avez besoin

To assemble the kit you need

10

13

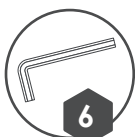

17

Pour fût de 200 litres

For drums, model 52.8 US gal

154 261 990

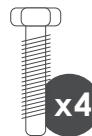
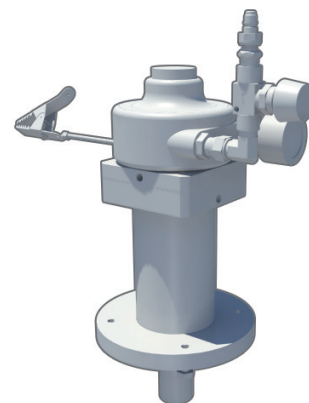

Pour monter le kit vous avez besoin

To assemble the kit you need

8

13



17

Représentation des produits Representation of the materials

Le fût n'est pas représenté lors du démontage et le remontage du Kit de transformation. Il sera donc considéré que cette première opération sera déjà établie par l'utilisateur.

Please note that the drum is not shown during the disassembly and assembly sequence of the transformation kit. It is considered that that first operation will be already executed by the user.

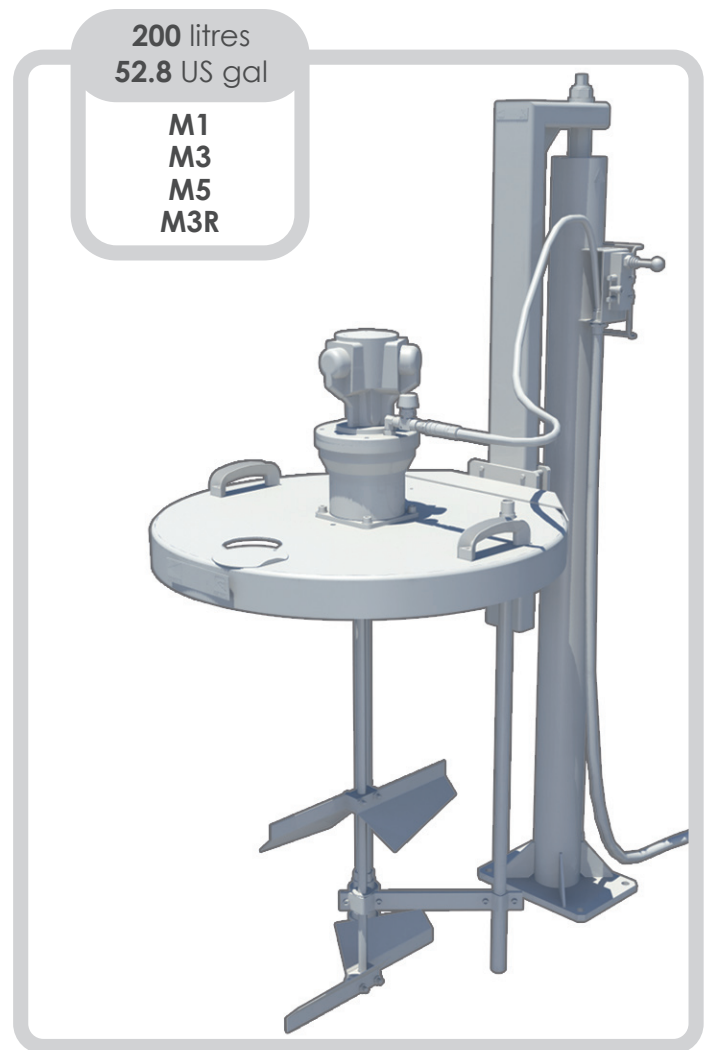
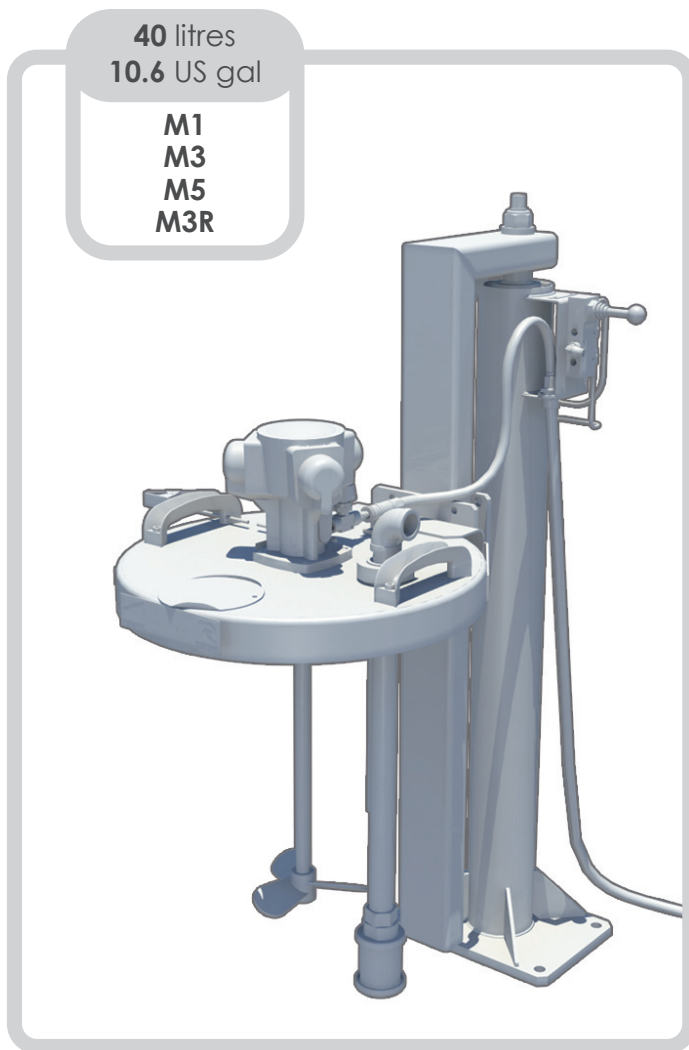

Les opérations de démontage et remontage du Kit de transformation seront représentées par le modèle de moteur M3R de 200 litres à titre d'exemple sur l'ensemble de la notice. Cependant certaines spécifications seront notifiées pour la capacité de 40 litres.

The disassembly and assembly sequences of the transformation kit will be shown only with the 200 L / 52.8 US gal M3R motor version. Nevertheless, some specifications will be indicated with the 40 Liter / 10.6 US gal version.

Légende de la notice originale Caption of the manual

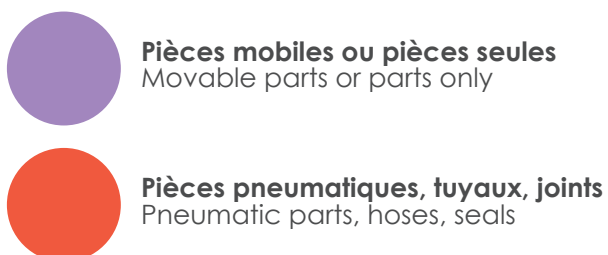

Sommaire du démontage et du remontage

Contents of the disassembly and assembly

Moteur M3R TONSON
M3R TONSON motor

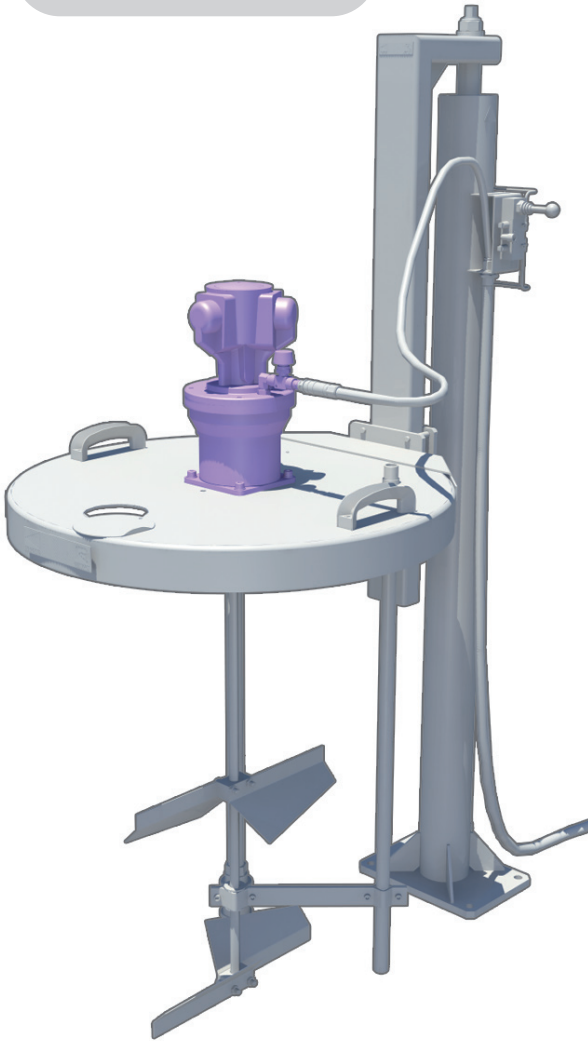

Kit de transformation GAST
GAST transformation kit

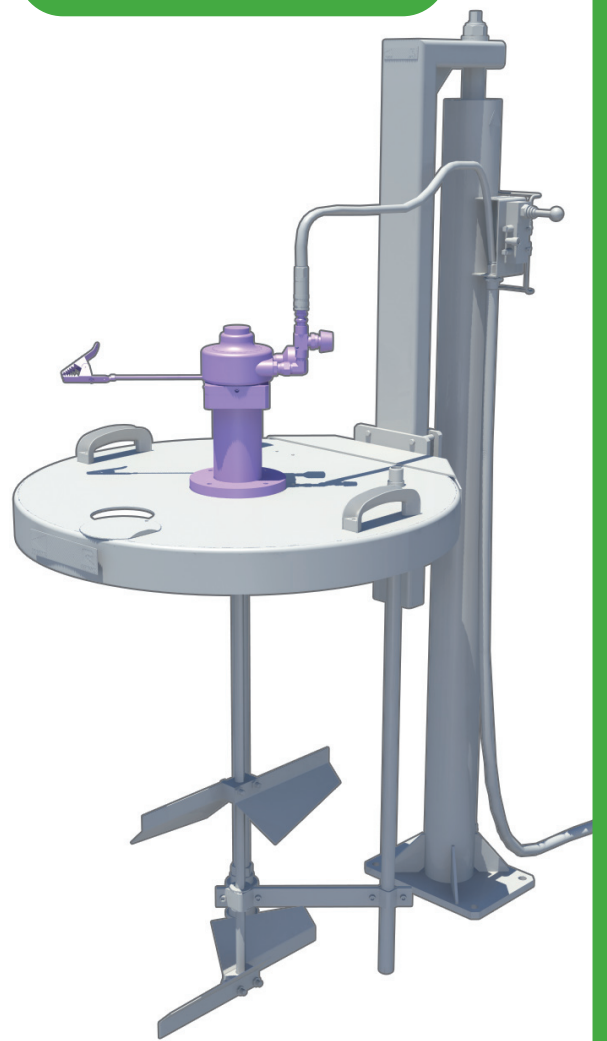

1 Sécuriser l'opération du démontage du moteur
Secure the sequence of the motor disassembly

2 Démontage du moteur M3R
M3R motor disassembly

3 Montage du Kit de transformation
Transformation kit assembly

4 Rebrancher l'alimentation d'air sur le moteur
Supply air to the motor

4

5

6 7

8

D L'opération de démontage est sécurisée
The disassembly sequence is secured

C Le moteur M3R est démonté
The M3R motor is disassembled

I Le kit de transformation est monté
The transformation kit is installed

D L'alimentation d'air est rebranchée
Air supply is installed

Sécuriser l'opération de démontage du moteur
Secure the sequence of the motor disassembly

1

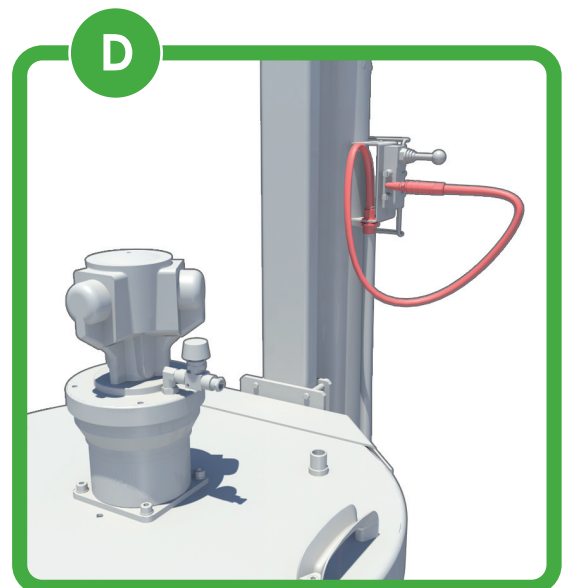
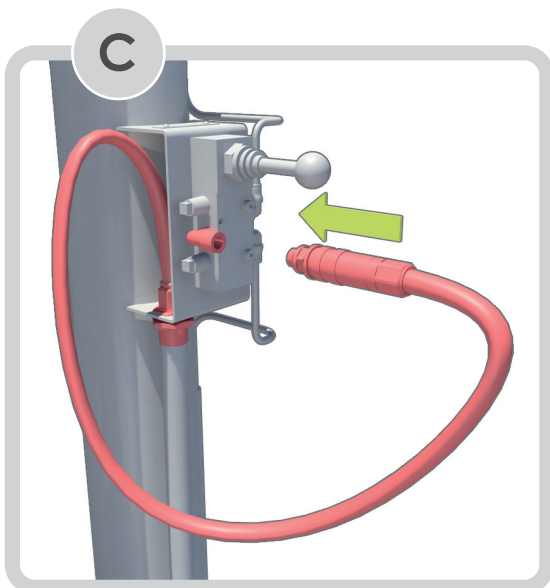
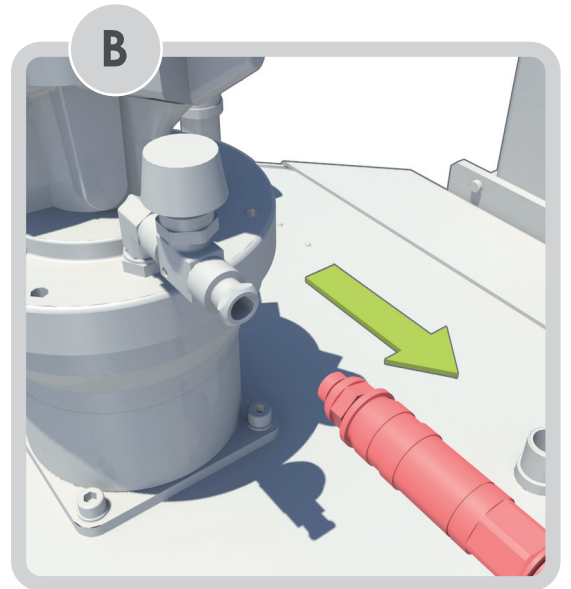
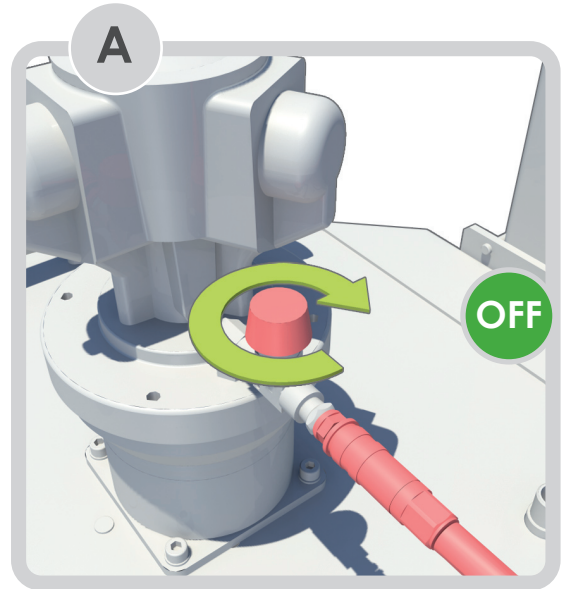
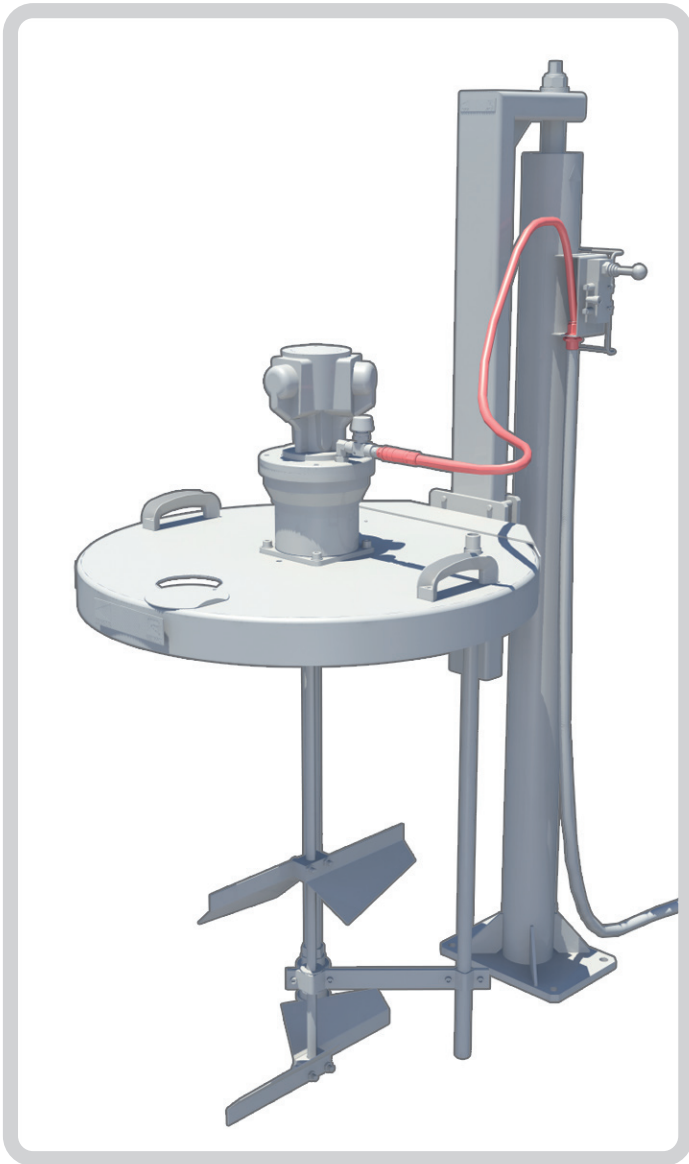

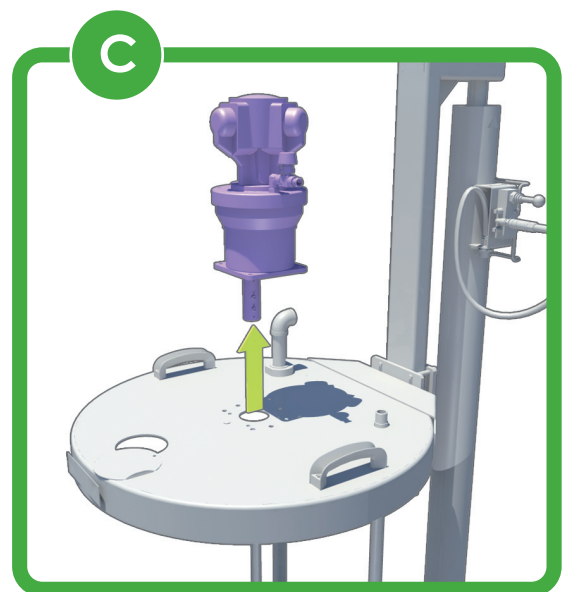
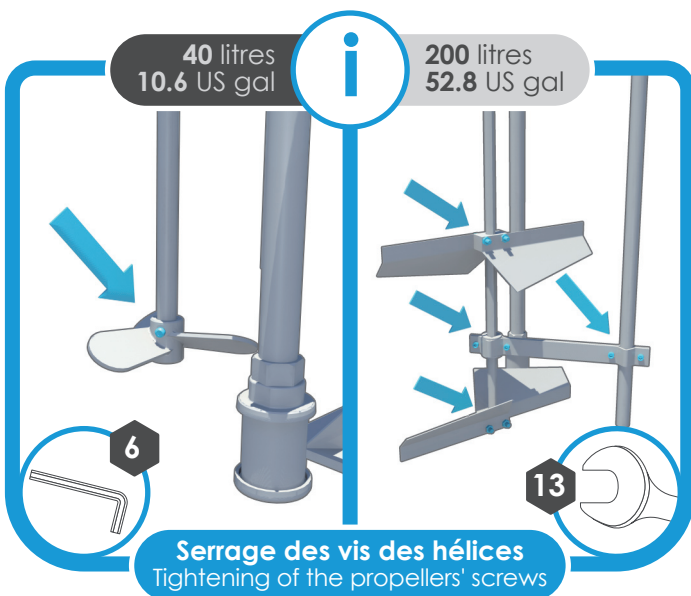
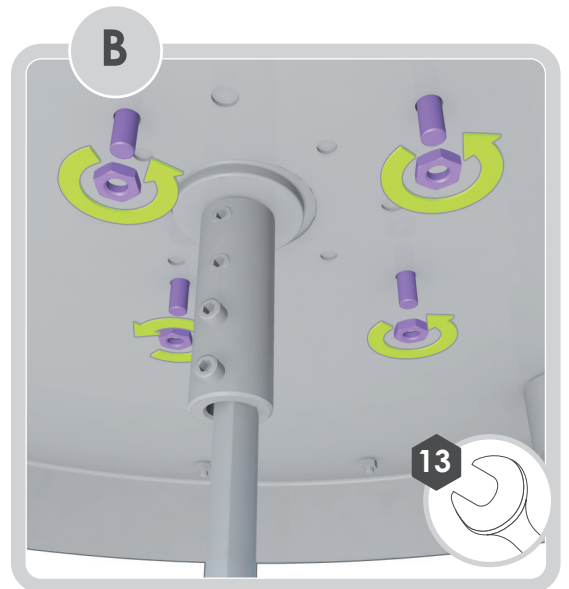
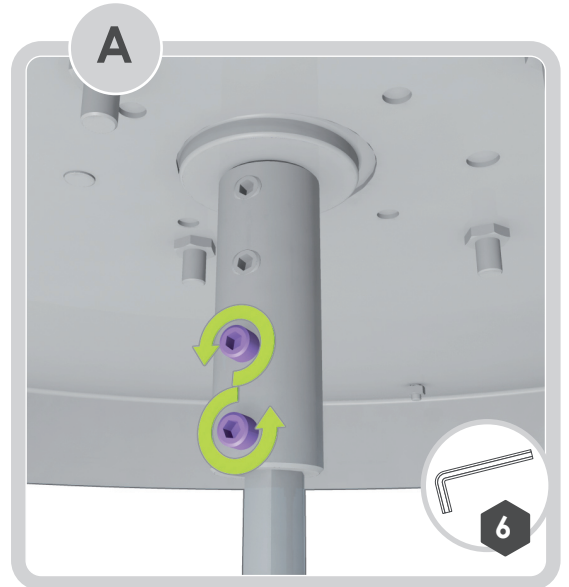
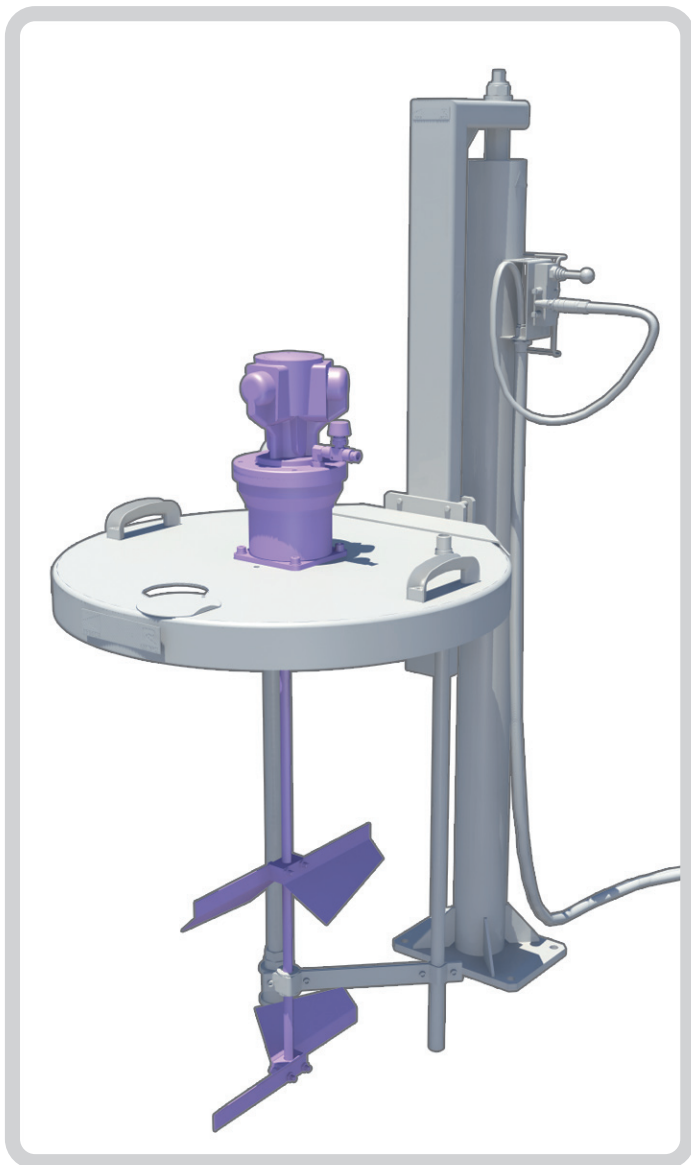

Montage du Kit de transformation Transformation kit assembly

3

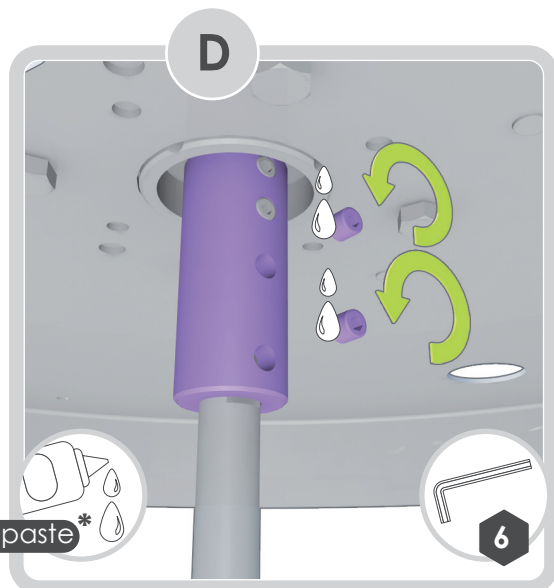
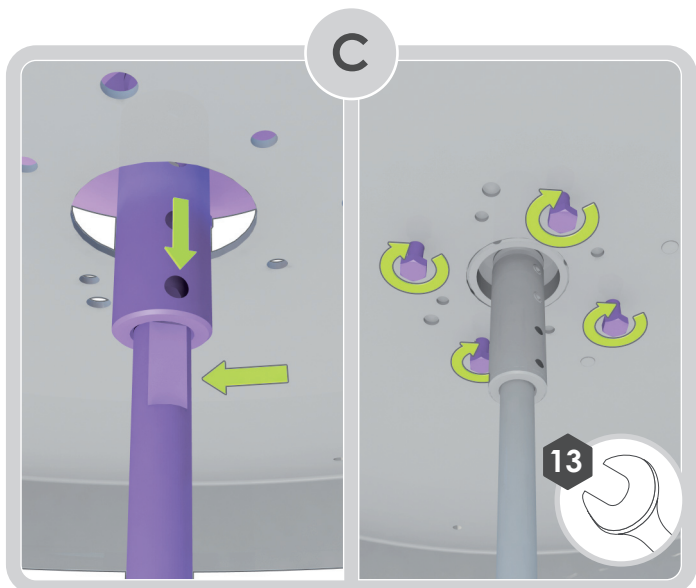
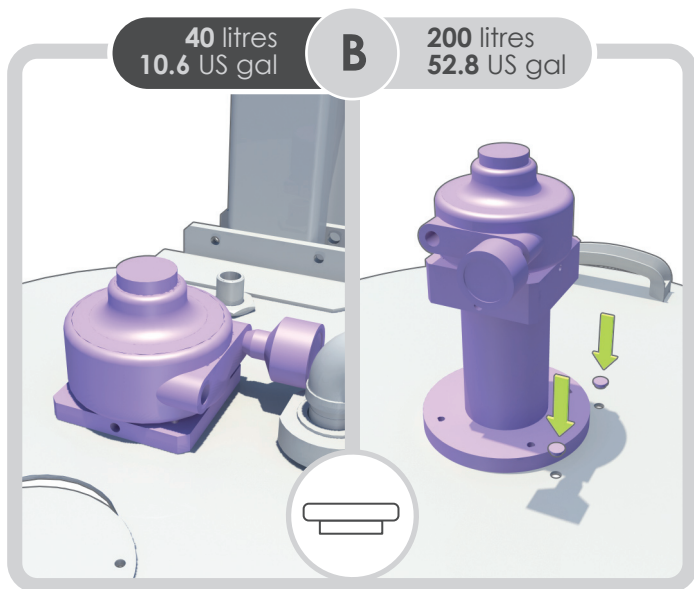
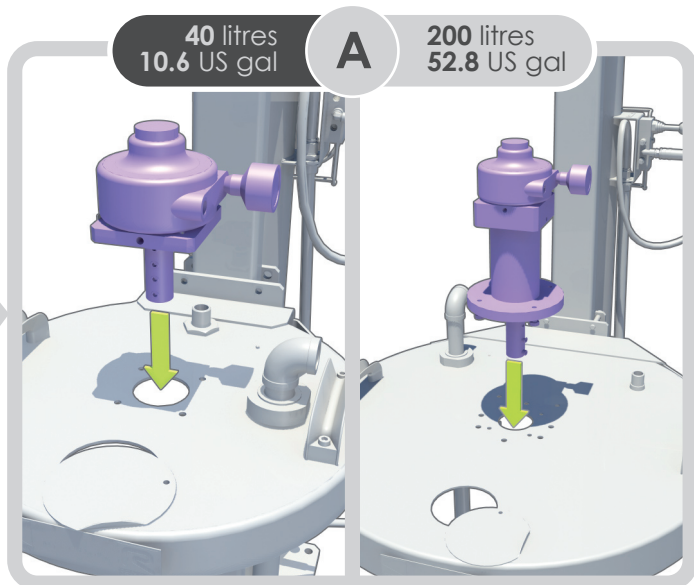
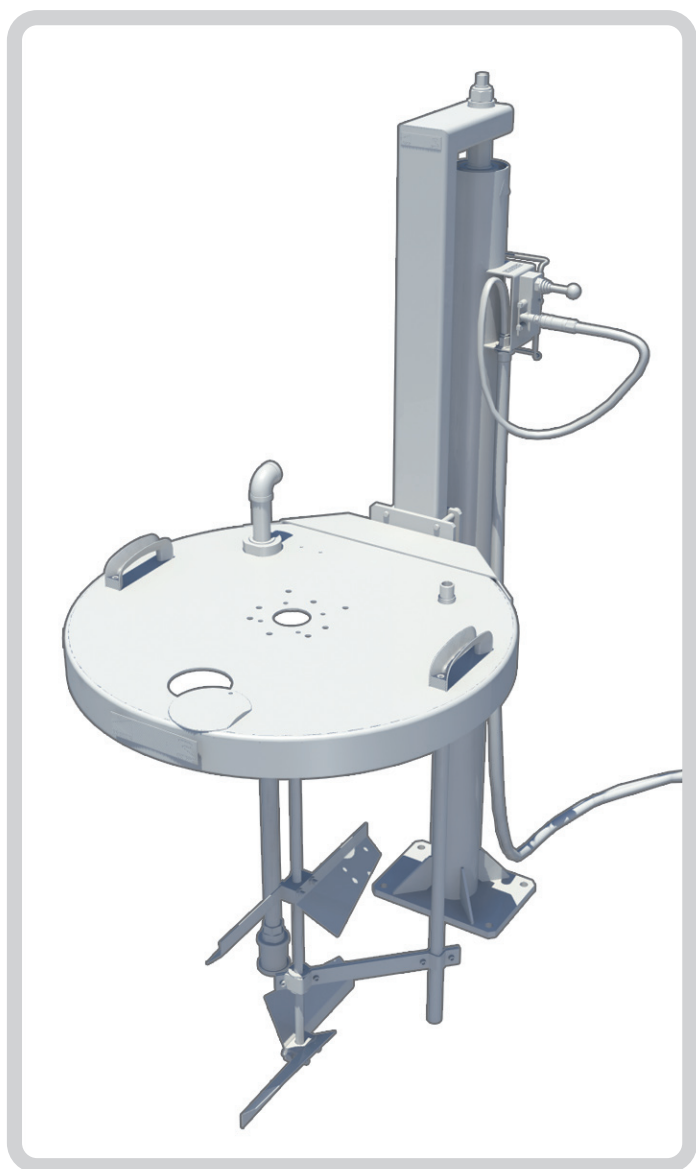

* Colle anaérobie tube étanche au PTFE Médium strenght anaerobic pipe sealant

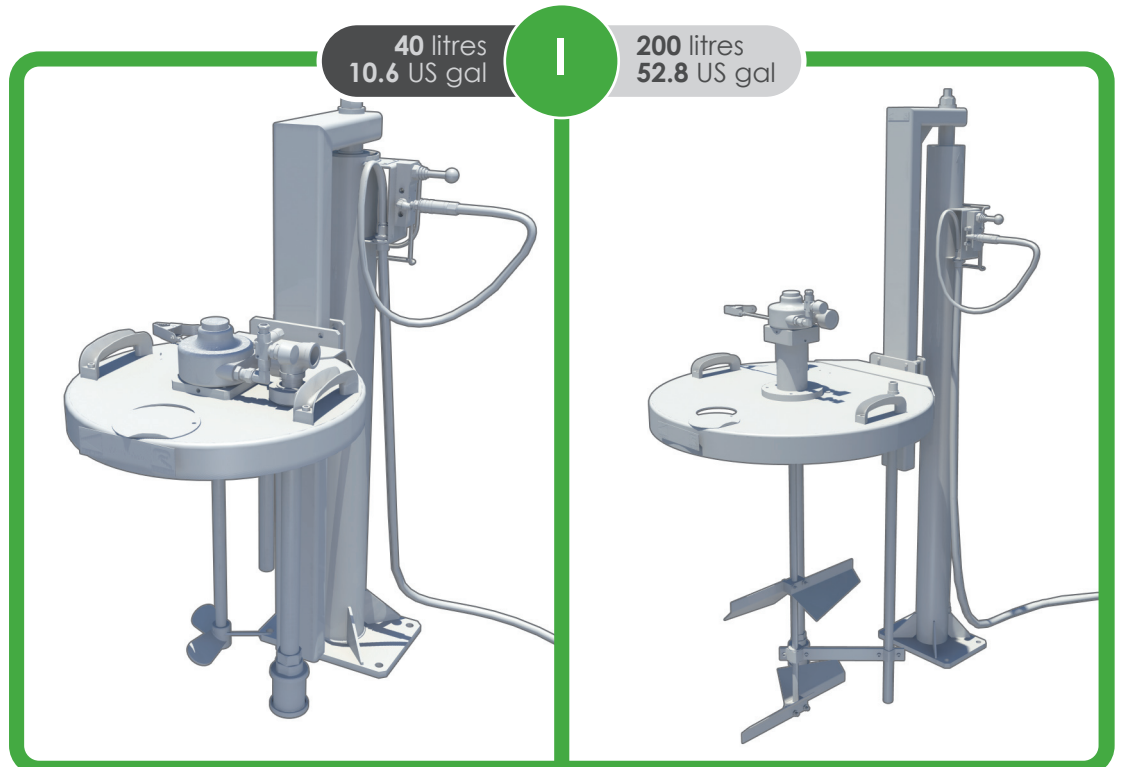
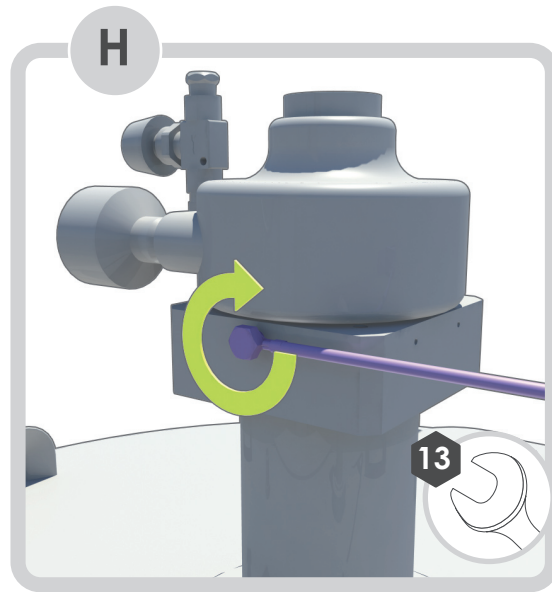
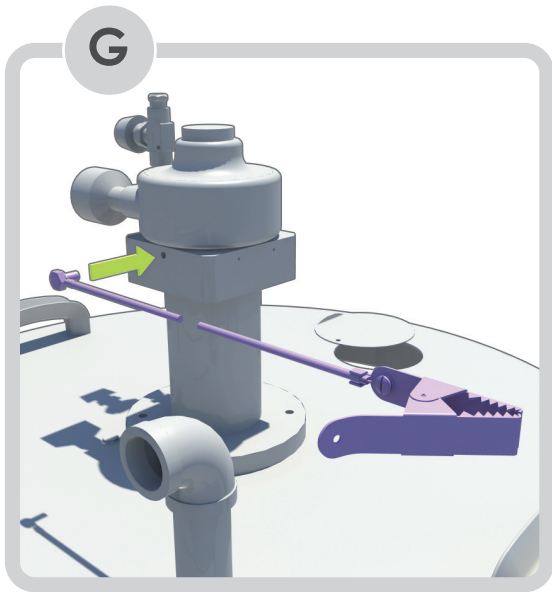
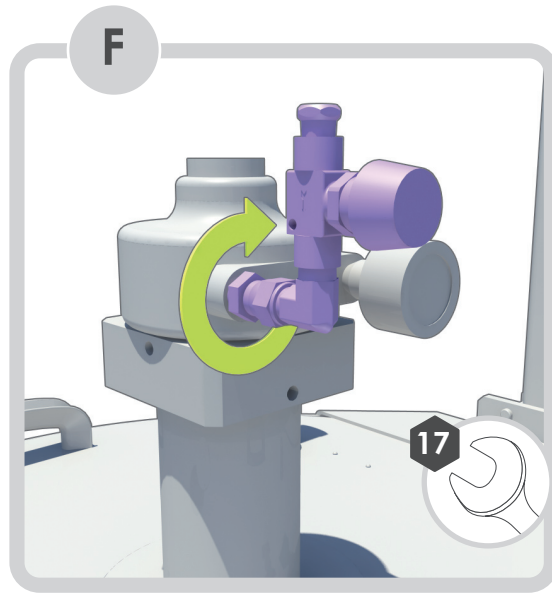
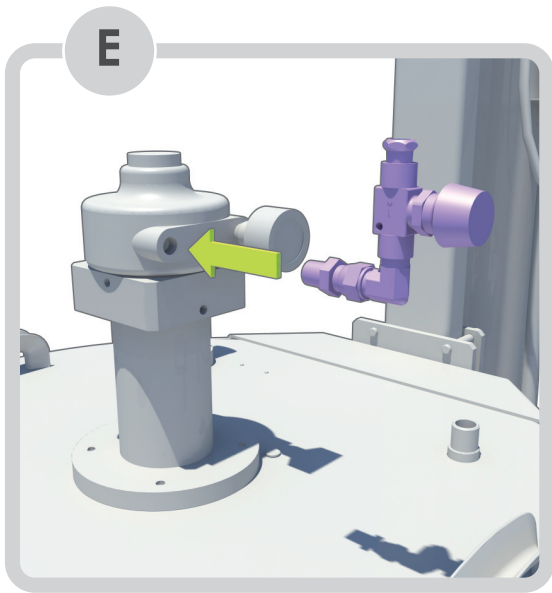

Rebrancher l'alimentation d'air sur le moteur
Supply air to the motor

4

