

DOCUMENTATION
AIRLESS MANUAL GUN
SFLOW™

Manual : 582.094.110-UK - 1711

Date: 23/11/17

Supersede : 27/05/16

Modif.:

TRANSLATION FROM THE ORIGINAL MANUAL

IMPORTANT : Before assembly and start-up, please read and clearly understand all the documents relating to this equipment (professional use only).

THE PICTURES AND DRAWINGS ARE NON CONTRACTUAL. WE RESERVE THE RIGHT TO MAKE CHANGES WITHOUT PRIOR NOTICE..

SAMES KREMLIN SAS
13, chemin de Malacher
38 240 - MEYLAN - France
 : 33 (0)4 76 41 60 60

www.sames-kremlin.com



<p style="text-align: center;">FR</p> <p><u>Pour une utilisation sûre, Il est de votre responsabilité de :</u></p> <ul style="list-style-type: none"> • Lire attentivement tous les documents contenus dans le CD joint avant la mise en service de l'équipement, • D'installer, d'utiliser, d'entretenir et de réparer l'équipement conformément aux préconisations de SAMES KREMLIN ainsi qu'aux réglementations nationales et/ou locales, • Vous assurez que les utilisateurs de cet équipement ont été formés, ont parfaitement compris les règles de sécurité et qu'ils les appliquent. 	<p style="text-align: center;">UK</p> <p><u>To ensure safe use of the machinery, it is your responsibility to:</u></p> <ul style="list-style-type: none"> • Carefully read all documents contained on the enclosed CD before putting the machinery into service, • Install, use, maintain and repair the machinery in accordance with SAMES KREMLIN's recommendations and national and/or local regulations, • Make sure that the users of the machinery have received proper training and that they have perfectly understood the safety rules and apply them. 	<p style="text-align: center;">DE</p> <p><u>Eine sichere Nutzung setzt voraus, dass Sie: :</u></p> <ul style="list-style-type: none"> • alle in der CD enthaltenen Dokumente vor der Inbetriebnahme der Anlage aufmerksam lesen, • die Anlage im Einklang mit den Empfehlungen von SAMES KREMLIN sowie mit den nationalen und/oder lokalen Bestimmungen installieren, verwenden, warten und reparieren, • sich vergewissern, dass die Nutzer dieser Anlage angemessen geschult wurden, die Sicherheitsbestimmungen verstanden haben und sie anwenden.
<p style="text-align: center;">ES</p> <p><u>Para una utilización segura, será de su responsabilidad:</u></p> <ul style="list-style-type: none"> • leer atentamente todos los documentos que se incluyen en el CD adjunto antes de la puesta en servicio del equipo, • instalar, utilizar, efectuar el mantenimiento y reparar el equipo con arreglo a las recomendaciones de SAMES KREMLIN y a la normativa nacional y/o local, • cerciorarse de que los usuarios de este equipo han recibido la formación necesaria, han entendido perfectamente las normas de seguridad y las aplican. 	<p style="text-align: center;">IT</p> <p><u>Per un uso sicuro, vi invitiamo a:</u></p> <ul style="list-style-type: none"> • leggere attentamente tutta la documentazione contenuta nel CD allegato prima della messa in funzione dell'apparecchio, • installare, utilizzare, mantenere e riparare l'apparecchio rispettando le raccomandazioni di SAMES KREMLIN, nonché le normative nazionali e/o locali, • accertarvi che gli utilizzatori dell'apparecchio abbiano ricevuto adeguata formazione, abbiano perfettamente compreso le regole di sicurezza e le applichino. 	<p style="text-align: center;">PT</p> <p><u>Para uma utilização segura, é da sua responsabilidade:</u></p> <ul style="list-style-type: none"> • Ler atentamente todos os documentos incluídos no CD em anexo antes de pôr o equipamento em funcionamento, • Proceder à instalação, utilização, manutenção e reparação do equipamento de acordo com as preconizações de SAMES KREMLIN, bem como com outros regulamentos nacionais e/ou locais aplicáveis, • Assegurar-se que os utilizadores do equipamento foram devidamente capacitados, compreenderam perfeitamente e aplicam as devidas regras de segurança.
<p style="text-align: center;">NL</p> <p><u>Voor een veilig gebruik dient u:</u></p> <ul style="list-style-type: none"> • alle document op de bijgevoegde cd aandachtig te lezen alvorens het apparaat in werking te stellen, • het apparaat te installeren, gebruiken, onderhouden en repareren volgens de door SAMES KREMLIN gegeven aanbevelingen en overeenkomstig de nationale en/of plaatselijke reglementeringen, • zeker te stellen dat de gebruikers van dit apparaat zijn opgeleid, de veiligheidsregels perfect hebben begrepen en dat zij die ook toepassen. 	<p style="text-align: center;">SE</p> <p><u>För en säker användning av utrustningen ansvarar ni för följande:</u></p> <ul style="list-style-type: none"> • Läs noga samtliga dokument som finns på den medföljande cd-skivan innan utrustningen tas i drift. • Installera, använd, underhåll och reparera utrustningen enligt anvisningarna från SAMES KREMLIN och enligt nationella och/eller lokala bestämmelser. • Försäkra er om att användare av denna utrustning erhållit utbildning, till fullo förstått säkerhetsföreskrifterna och tillämpar dem. 	<p style="text-align: center;">FI</p> <p><u>Käytön turvallisuuden varmistamiseksi velvollisuutesi on:</u></p> <ul style="list-style-type: none"> • Lukea huolella kaikki CD:llä olevat asiakirjat ennen laitteiston käyttöönottoa, • Noudataa laitteiston asennuksessa, käytössä, kunnossapidossa ja huollossa SAMES KREMLIN in suosituksia sekä kansallisia ja/tai paikallisia määräyksiä, • Varmistaa, että laitteiston käyttäjät ovat koulutettuja ja ymmärtävät täysin turvallisuusmääräykset ja miten niitä sovelletaan.
<p style="text-align: center;">PL</p> <p><u>Dla zapewnienia bezpiecznego użytkowania na użytkownika spoczywa obowiązek:</u></p> <ul style="list-style-type: none"> • Uwážnego zapoznania się ze wszystkimi dokumentami znajdującymi się na załączonej płycie CD przed pierwszym uruchomieniem urządzenia, • Instalowania, użytkowania, konserwacji i naprawy urządzenia zgodnie z zaleceniami firmy SAMES KREMLIN oraz z przepisami miejscowymi, • Upewnienia, że wszyscy przeszkoleni użytkownicy urządzenia zrozumieli zasady bezpieczeństwa i stosują się do nich. 	<p style="text-align: center;">CS</p> <p><u>Pro bezpečné používání jste povinni:</u></p> <ul style="list-style-type: none"> • Před uvedením zařízení do provozu si pozorně přečt' veškeré dokumenty obsažené na přiloženém CD, • Nainstalovat, používat, udržívat a opravovat zařízení v souladu s pokyny firmy SAMES KREMLIN a s národními a/nebo místními legislativními předpisy, • Ujistit se, že uživatelé tohoto zařízení byli vyškoleni, že dokonale pochopili bezpečnostní pravidla a že je dodržíjí. 	<p style="text-align: center;">SL</p> <p><u>Za varno uporabo ste dolžni:</u></p> <ul style="list-style-type: none"> • natančno prebrati vse dokumente na CD pred zagonom stroja, • instalirati, uporabljati, vzdrževati in popravljati opremo po določilih SAMES KREMLIN in v skladu z veljavnimi nacionalnimi in/ali lokalnimi predpisi, • poskrbeti, da so uporabniki te opreme ustrezno usposobljeni, poznajo varnostne predpise in da jih upoštevajo.
<p style="text-align: center;">SK</p> <p><u>V záujme bezpečného je vašou povinnosťou:</u></p> <ul style="list-style-type: none"> • pozorne si prečítať všetky dokumenty obsiahnuté na priloženom CD predtým, ako zariadenie uvediete do prevádzky, • nainštalovať, používať, udržiavať a opravovať zariadenie v súlade s odporúčaniami spoločnosti SAMES KREMLIN a národnými a/alebo miestnymi predpismi, • uistiť sa, že používatelia tohto zariadenia boli zaškolení, riadne porozumeli pravidlám bezpečnosti a používajú ich. 	<p style="text-align: center;">HU</p> <p><u>A biztonságos használat érdekében az Ön felelőssége, hogy:</u></p> <ul style="list-style-type: none"> • a berendezés üzembe helyezésé előtt figyelmesen elolvassa a mellékelt CD által tartalmazott összes dokumentumot, • a berendezést a SAMES KREMLIN ajánlásainak valamint a nemzeti és/vagy helyi szabályozásoknak megfelelően helyezze üzembe, használja, tartsa karban és javítsa, • megbizonyosodjon róla, hogy a berendezés felhasználói képzettek, tökéletesen megértették és alkalmazzák a biztonsági előírásokat. 	<p style="text-align: center;">RO</p> <p><u>Penru o utilizare sigură, este responsabilitatea dvs. să:</u></p> <ul style="list-style-type: none"> • Citiți cu atenție toate documentele de pe CD-ul anexat, înainte de punerea în funcțiune a echipamentului, • Instalați, utilizați, întrețineți și reparați echipamentul conform instrucțiunilor SAMES KREMLIN precum și reglementărilor naționale și/sau locale, • Vă asigurați că utilizatorii acestui echipament au fost instruiți, au înțeles perfect regulile de securitate și le aplică integral.

Déclaration(s) de conformité au verso de ce document / Declaration(s) of conformity at the back of this document / Konformitätserklärung(en) auf der Rückseite dieser Unterlage / Declaración (es) de conformidad en el reverso de este documento / Dichiarazione/i di conformità sul retro del presente documento / Declaração(ões) de conformidade no verso do documento / Conformiteitsverklaring(en) op de keerzijde van dit document / Försäkran om överensstämmelse på omstående sida av detta dokument / Vaatimustenmukaisuusvakuutukset tämän asiakirjan kääntöpuolella / Deklaracja(e) zgodności na odwrocie dokumentu / Prohlášení o shodě se nachází/nacházejí na zadní straně tohoto dokumentu / Deklaracja(e) o skladnosti na hrbtni strani tega dokumenta / Vyhlášení/-a o zhode sa nachádzajú na zadnej strane dokumentu / A dokumentum hátlapján szereplő megfelelőségi nyilatkoz(ok) / Declarații de conformitate pe versoul acestui document



DECLARATION UE DE CONFORMITE
UE DECLARATION OF CONFORMITY
EU-KONFORMITÄTSEKTLÄRUNG
DECLARACIÓN UE DE CONFORMIDAD
DICHIARAZIONE DI CONFORMITÀ UE
DECLARAÇÃO UE DE CONFORMIDADE
EU-CONFORMITEITSVERKLARING
EU-FÖRSÄKRAN OM ÖVERENSSTÄMMELSE
EU-VAAITIMUKSEN MUKAISUUSVAKUUTUS
DEKLARACJA ZGODNOŚCI UE
EU PROHLÁŠENÍ O SHODĚ
IZJAVA EU O SKLADNOSTI
VYHLÁSENIE O ZHODE
EU-MEGFELELŐSÉGI NYILATKOZAT
DECLARAȚIA DE CONFORMITATE UE

Le fabricant / The manufacturer / Der Hersteller / El fabricante / Il produttore / O fabricante / De fabrikant / Tillverkare / Valmistaja / Producent / Výrobce / Proizvajalec / Výrobca / Gyártó / Fabricantul:	SAMES KREMLIN SAS 13, chemin de Malacher 38 240 - MEYLAN - FRANCE Tél. : 33 (0)4 76 41 60 60
---	--

Déclare que le matériel désigné ci-après / Herewith declares that the equipment / erklart hiermit, dass die / Declara que el material designado a continuación / Dichiaro che il materiale sottoindicato / Declara que o material a seguir designado / verklaart dat de hieronder aangeduide apparatuur / Kungör att den utrustning som anges här nedan / ilmoittaa, että alla mainitut laitteistot / Oświadczam, że wymienione poniżej urządzenia / Prohlašuje, že níže uvedené vybavení / Izjavljam, da je opisana oprema spodaj / Vyhlasuje, že zariadenie uvedené nižšie / Kijelenti, hogy a megjelölt anyag a továbbiakban / Declară că echipamentul precizat mai jos:

PISTOLET MANUEL DE PULVERISATION AIRLESS® / AIRLESS MANUAL SPRAYING GUN
DIE AIRLESS® HAND-SPRITZPISTOLE / PISTOLA MANUAL DE PULVERIZACIÓN AIRLESS®

SFLOW™ 275
SFLOW™ 450

Est conforme à la législation d'harmonisation de l'Union applicable suivante / Is in conformity with the relevant Union harmonisation legislation / Erfüllt die einschlägigen Harmonisierungsrechtsvorschriften der Union / es conforme con la legislación de armonización pertinente de la Unión / è conforme alla pertinente normativa di armonizzazione dell'Unione / in overeenstemming met de desbetreffende harmonisatiewetgeving van de Unie / med den relevanta harmoniserade unionslagstiftningen / on asiaa koskevan unionin yhdenmukaistamislainsäädännön vaatimusten mukainen / jest zgodny z odpowiednimi wymaganiami unijnego prawodawstwa harmonizacyjnego / Shoduje se s následující příslušnou evropskou harmonizační legislativou / V skladu s harmonizirano zakonodajo Unije / Je v súlade s uplatniteľnými harmonizačnými právnymi predpismi EÚ / Megfelel a következő alkalmazandó uniós harmonizációs szabályozásnak / Este conform cu legislația aplicabilă de armonizare de mai jos

Directive ATEX / ATEX Directive / ATEX Richtlinie / Directiva ATEX / Direttiva ATEX / Diretiva ATEX / ATEX-Richtlijn / ATEX-direktivet / ATEX-direktivi / Dyrektywa ATEX / Směrnice ATEX / Direktiva ATEX / Smernica ATEX / ATEX-irányelv	 II 2G Ex h IIA T6 X Gb	2014/34/UE
Procédure d'évaluation de la conformité : Module A Documentation technique (Annexe VIII) archivée par : / Conformity assessment procedure: Module A Technical documentation (ANNEX VIII) recorded by: / Verfahren zur Konformitätsbewertung: Modul A Technische Unterlagen (ANLAGE VIII) archiviert durch: / Procedimiento de evaluación de la conformidad: Módulo A Documentación técnica (ANEXO VIII) archivada por: / Procedura di valutazione della conformità: Modulo A Documentazione tecnica (ALLEGATO VIII) archiviata a cura di: / Procedimento de avaliação da conformidade: Módulo A Documentação técnica (ANEXO VIII) arquivada por: / Conformiteitsbeoordelingsprocedure: Module A Technische documentatie (BIJLAGE VIII) gearhiveerd door: / Förfarande för bedömning av överensstämmelse: Modul A Teknisk dokumentation (BILAGA VIII) arkiverad av: / Vaatimusten mukaisuusarviointimenetelmä: moduuli A Tekninen dokumentaatio (LIITE VIII) arkistoitu: / Procedura oceny zgodności: Modul A Dokumentacja technicznej (ZAŁĄCZNIK VIII) zarchiwizowane przez: / Postup posuzování shody: Modul A Technická dokumentace (PŘÍLOHA VIII) archivována: / Postopek preverjanja skladnosti: Modul A Tehnična dokumentacija (PRILOGA VIII), arhiviral: / Postup posudzovania zhody: Modul A Technická dokumentácia (PRÍLOHA VIII) archivovaná prostredníctvom: / Megfelelőségértékelési eljárás: A. modul Műszaki dokumentáció (VIII. MELLÉKLET) archiválta: / Procedura de evaluare a conformității: Modulul A Documentația tehnică (ANEXA VIII) este arhivată de: INERIS 0080 - 60550 Verneuil-en-Halatte - France		

La présente déclaration de conformité est établie sous la seule responsabilité du fabricant / This declaration of conformity is issued under the sole responsibility of the manufacturer / Die alleinige Verantwortung für die Ausstellung dieser Konformitätserklärung trägt der Hersteller / La presente declaración de conformidad se expide bajo la exclusiva responsabilidad del fabricante / La presente dichiarazione di conformità è rilasciata sotto la responsabilità esclusiva del fabbricante / A presente declaração de conformidade é emitida sob a exclusiva responsabilidade do fabricante / Deze conformiteitsverklaring wordt verstrekt onder volledige verantwoordelijkheid van de fabrikant / Denna försäkran om överensstämmelse utfärdas på tillverkarens eget ansvar / Tämä vaatimustenmukaisuusvakuutus on annettu valmistajan yksinomaisella vastuulla / Niniejsza deklaracja zgodności wydana zostaje na wyłączną odpowiedzialność producenta / Toto prohlášení o skodě se vydává na výhradní odpovědnost výrobce / Za izdajo te izjave o skladnosti je odgovoren izključno proizvajalec / Toto vyhlásenie o zhode sa vydáva / na vlastnú zodpovednosť výrobcu / Ezt a megfelelőségi nyilatkozatot a gyártó kizárólagos felelőssége mellett adják ti / Prezenta declarație de conformitate este emisă pe răspunderea exclusivă a producătorului.



Philippe PROVENAZ

Directeur Innovation & Développement / Innovation & Development
Director / Direktor für Innovation & Entwicklung / Director de
Inovación y Desarrollo / Direttore Innovazione e sviluppo
/ Diretor de Inovação / Manager Innovatie en Ontwikkeling / Direktör
för Forskning och Utveckling / Innovaatio- ja kehitysjohtaja
/ Dyrektor ds. Innowacji I Rozwoju / Ředitel pro inovace a vývoj
/ Direktor za inovacije in razvoj / Riaditel' pre inováciu a rozvoj
/ Innovációs és fejlesztési igazgató / Director Inovație și Dezvoltare

Fait à Meylan, le / Established in Meylan, on / Geschehen zu Meylan, am / En Meylan, a / Redatto a Meylan, / Vastgesteld te Meylan, / Utformat i
Meylan, den / Meylan, Ranska, / Sporządzono w Meylan, dnia / Meylan, dnia / V Meylanu, / V Meylan dňa / Kelt Meylanban, / Întocmită la Meylan,
pe data de 17/11/2017 - 11/17/2017



INSTALLATION AND SAFETY INSTRUCTIONS

TRANSLATION OF THE ORIGINAL MANUAL

IMPORTANT : Before assembly and start-up, please read and clearly understand all the documents relating to this equipment (professional use only).

THE PICTURES AND DRAWINGS ARE NON CONTRACTUAL. WE RESERVE THE RIGHT TO MAKE CHANGES WITHOUT PRIOR NOTICE.

KREMLIN - REXSON

150, avenue de Stalingrad

93 245 - STAINS CEDEX – France

☎ : 33 (0)1 49 40 25 25 Fax : 33 (0)1 48 26 07 16

www.kremlin-rexson.com

1. SAFETY INSTRUCTIONS

GENERAL SAFETY INSTRUCTIONS



CAUTION : The equipment can be dangerous if you do not follow our instructions concerning installation and servicing described in this manual and in accordance with applicable European standards and local national safety regulations.

Please carefully read all the instruction literature before operating your equipment.

Only trained operators can use the equipment (To acquire an essential training, please contact the "KREMLIN REXSON University" training center - Stains).

The foreman must ensure that the operator has understood the safety instructions for this equipment as well as the instructions in the manuals for the different parts and accessories.

Read carefully all instruction manuals, label markings before operating the equipment.



















Incorrect use may result in injury. This equipment is for professional use only. It must be used only for what it has been designed for. Never modify the equipment. The parts and accessories supplied must be regularly inspected. Defective or worn parts must be replaced.

Guards (motor cover, coupling shields, connectors,...) have been designed for a safe use of the equipment.
The manufacturer will not be held responsible for bodily injury or failure and / or property damage due to destruction, the overshadowing or the partial or total removal of the guards.

Never exceed the equipment components' maximum working pressure.

Comply with regulations concerning safety, fire risks, electrical regulations in force in the country of final destination of the material. Use only products or solvent compatible with the parts in contact with the material (refer to data sheet of the material manufacturer).

PICTOGRAMS

					
NIP HAZARD	WARNING MOVING ELEVATOR	WARNING MOVING PARTS	WARNING MOVING SHOVEL	DO NOT EXCEED THIS PRESSURE	HIGH PRESSURE HAZARD
					
RELIEF OR DRAIN VALVE	WARNING HOSE UNDER PRESSURE	WEAR GLASSES OBLIGATORY	WEAR OF GLOVES IS OBLIGATORY	PRODUCT VAPOR HAZARDS	WARNING HOT PARTS OR AREAS
					
ELECTRICAL HAZARD	WARNING FIRE HAZARDS	EXPLOSION HAZARDS	GROUNDING	WARNING (USER)	WARNING SERIOUS INJURIES

FIRE - EXPLOSION - SPARKS - STATIC ELECTRICITY HAZARDS

A poor earth connection, inadequate ventilation, sparks or static electricity can cause an explosion or fire. to avoid these risks when using or servicing KREMLIN REXSON equipment, the following safety procedures must be followed :



- ensure a good earth connection and ground the parts to be handled i.e. solvents, materials, components and equipment,
- ensure adequate ventilation,
- keep working area clean and free from waste solvents, chemicals, or solid waste i.e. rags, paper and empty chemicals drums,
- never use electrical switches / power if in an atmosphere of volatile solvent vapour,
- stop working immediately in case of electrical arcs,
- never store chemicals and solvents in the working area.
- use paint whose flash point is the highest possible to prevent from any formation of gas and inflammable vapours (refer to materials' safety instructions),
- install a cover on the drums to reduce the diffusion of gas and vapours in the spraybooth.

TOXIC PRODUCT HAZARDS

Toxic products or vapours can cause severe injury not only through contact with the body, but also if the products are ingested or inhaled. It is imperative :



- to know the material products and their risks,
- notified or hazardous materials must be stored in accordance with the regulations,
- the material must be stored in an appropriate container, never place materials in a container where there is a risk of spillage or leakage,
- a procedure must be applied for the safe disposal of waste material. It must comply with all prevailing regulations and legislations of the country where the equipment is to be used,
- protective clothing should always be worn in compliance with the material manufacturers' recommendations,
- depending on the application and chemical safety instructions, safety glasses, hearing protective earplug, gloves, foot wear, protective masks and possible breathing equipment should be worn to comply with the regulations (Refer to chapter "Safety equipment of KREMLIN selection guide).

CAUTION!

It is forbidden to use material containing high concentrations of halogenated hydrocarbon solvents with **aluminium or zinc fillers** .Non-compliance with the instructions may cause explosion risk causing serious or fatal injury.

EQUIPMENT REQUIREMENTS

Guards (motor cover, coupling shields, connectors,...) have been designed for a safe use of the equipment.

The manufacturer will not be held responsible for bodily injury or failure and / or property damage due to destruction, the overshadowing or the partial or total removal of the guards.

PUMP



Before carrying out any work, it is imperative to read and clearly understand the disassembly and reassembly instructions before servicing. The operator must understand the equipment and the safety instructions. These instructions are available in the equipment manuals.



The air motor is designed to be mounted with a pump. Never modify any components or couplings. When operating, please keep hands away from moving parts. Before starting up the equipment, please read the PRESSURE RELIEF instructions. Please ensure that any relief or drain valves fitted are in good working order.

HOSES

- Keep hoses out of circulation areas, moving parts or hot surfaces,
- Never expose product hoses to temperature higher than + 60°C / 140° F or lower than 0°C / 32° F,
- Never pull or use the hoses to move the equipment,
- Tighten all fittings as well as the hoses before operating the equipment,
- Check the hoses regularly; change them if they are damaged,
- Never exceed the working pressure (WP) indicated on the hose.

USED PRODUCTS

Considering the wide variety of products that are available and can be used in our equipment it is impossible to check and make recommendations for all chemical data, regarding the risks of possible chemical attack and their long term chemical reaction

KREMLIN REXSON can not be held liable for :

- Compatibility of wetted parts,
- Risks to staff and the surroundings,
- for worn or defective parts, for faulty equipment or units, or the quality of final product.

It is the responsibility of the user to know and prevent any possible risks such as toxic vapours, fires or explosions. He shall determine the risks of immediate reactions or pursuant to repeated exposures of the staff,

KREMLIN REXSON shall not be liable for physical injuries, direct or indirect material damages caused by the use of chemicals.

2. HANDLING



Check the weight and the dimensions of the equipment

(refer to 'Technical features' section of the instruction manual

If weight and dimensions are too important, the unloading must be carried out by means of a forklift or any other appropriate means with a qualified personnel and in a clear horizontal area to prevent from risks of damage injury or an accident.

The centre of gravity is not in the centre of the machine : carry out by hand a stability-test after having lifted the whole at 10 cm / 3.937" maximum.

After the unloading, the handling of the whole (eg: elevator pump) is carried out by means of a pallet truck taking the bottom part of the frame.

Remark : Each pump motor is fitted with a ring. The ring is designed for the hoisting of one pump and can not be used for the handling of the complete machine.

3. STORING

Storing before installation :

- Storing ambient temperature : 0 / +50 °C / 0 / +122°F
- Protect the whole against dust, water trickling, dampness and shocks.

Storing after installation :

- Operating temperature : +15 / +35 °C / +59 / +138.2° F
- Protect the whole against dust, water trickling, dampness and shocks.

4. INSTALLATION OF THE EQUIPMENT

The machine is installed on a stable horizontal floor (for eg a concrete flag).



To avoid risks caused by static electricity, the equipment as well as its components must be grounded.

- **For the pumping equipments** (pumps, pneumatic rams, frame...), a section wire of 2.5 mm² is fixed on the material. Use this wire to connect the material to "the general ground". In case of severe environments (mechanical protection of the wire of earthing insufficient, vibrations, mobile material...) where function damages at the ground are probable, the user have to replace the provided wire of 2.5 mm² by a device more adapted to its environment (wire with a more important section, bonding strip, fixing by thimble with eyelet...),

The continuity of the ground must be controlled by a qualified electrician. If the continuity of the ground is not ensured, check the terminal, the wire and the earthing point. **Never** use the material without have solved this problem.

- In the severe cases of environments (mechanical protection of the wire of earthing insufficient, vibrations, mobile material...) where damages of the function put at the ground are probable, the user will have to replace the wire of 2.5 mm² provided, by a device more adapted to its environment (wire of more important section, bonding strip, fixing by thimble with eyelet...),
- **The gun** must be 'grounded' via a material hose or an air hose. In case of spraying by means of a gun with cup, the air hose must be conductive,
- **The materials to be painted** must also be grounded.

All the materials situated in the working area shall be grounded.



- **Never store** more than necessary inflammable materials inside the working area,
- The materials must be stored into **approved drums** and grounded,
- Use only grounded **metals containers** for the use of cleaning solvents,
- **Cardboard and paper are prohibited.**

5. MARKING OF THE EQUIPMENT

Each equipment has a marking plate.

The plate consists of the name of the manufacturer, the equipment part number and important information for correct use of the equipment (air pressure, electric power,...).



SPECIFIC SAFETY INSTRUCTIONS

Airmix® and Airless Guns

TRANSLATION FROM THE ORIGINAL MANUAL

IMPORTANT : Before assembly and start-up, please read and clearly understand all the documents relating to this equipment (professional use only).

THE PICTURES AND DRAWINGS ARE NON CONTRACTUAL. WE RESERVE THE RIGHT TO MAKE CHANGES WITHOUT PRIOR NOTICE.

SAMES KREMLIN SAS
13, chemin de Malacher
38 240 - MEYLAN - France
 : 33 (0)4 76 41 60 60

www.sames-kremlin.com

■ SPECIFIC SAFETY INSTRUCTIONS



Install a conductive fluid hose or a conductive air hose on the Airmix® gun to ground the gun.
Install a conductive fluid hose on the Airless gun to ground the gun.



Never exceed the maximum operating pressures of the equipment components.
(For the Airless guns - ASB : maximum working pressure = 240 bar / 3480 psi).
(For the Airless guns - SFLOW™ : maximum working pressure = 450 bar / 6526 psi).
(For the Airmix® guns - AVX : maximum working pressure = 200 bar / 2900.6 psi).



Always depressurize air and hoses before carrying out any servicing on the gun.



Never wipe the end of the nozzle with the fingers.
Never point the spray gun at anyone or at any part of the body.
Always use the safety trigger lock when leaving the gun unattended.



Always use the equipment in a well ventilated area to protect health and to minimise the risks from fire and explosions.



To protect the operator, protective clothing (gloves, respirator mask, glasses, clothes...) are required.

■ GENERAL SAFETY INSTRUCTIONS



CAUTION : The equipment can be dangerous if not used in accordance to the rules mentioned in this instruction manual. Please ensure you carefully read all the instructions before operating your equipment.

Only trained operators can use the equipment.

The foreman must ensure that the operator has perfectly understood the safety instructions for this equipment as well as the instructions in the manuals for the different parts and accessories.

Read carefully all instruction manuals, label markings before operating the equipment.

Comply with regulations concerning safety, fire risks, electrical supply and voltage in force in the country of final destination of the equipment.



 **Refer to the document**
"Installation and safety instructions"
(doc. 578.001.130-UK)



AIRLESS MANUAL GUN

SFLOW™

Disassembly / Reassembly

TRANSLATION FROM THE ORIGINAL MANUAL

IMPORTANT : Before assembly and start-up, please read and clearly understand all the documents relating to the equipment (professional use only).

THE PICTURES AND DRAWINGS ARE NOT CONTRACTUAL. WE RESERVE THE RIGHT TO MAKE CHANGES WITHOUT PRIOR NOTICE.

SAMES KREMLIN SAS

13, chemin de Malacher
38 240 - MEYLAN - France

☎ : 33 (0)4 76 41 60 60

www.sames-kremlin.com



CAUTION :

Before any intervention on the gun, shut off the compressed air supply and depressurize the circuits controlling the opening of the gun.

The gun is manufactured under the ATEX agreement and can no be modified. KREMLIN REXSON will no be held responsible for any failure to comply with that instruction.

Before removing a component of the gun, some precautions have to be taken :

- Shut off the pump main supply,
 - Lock the gun trigger with the safety device,
 - Relieve pressure from circuit by opening pump pressure relief valve,
 - Carefully loosen the gun swivel.
- ➡ **IMPORTANT : never work on gun when connected to hose.**

Always engage the trigger lock-off when gun is not spraying.

Before reassembling the different components, some precautions must be taken :

- **Clean all the parts with the appropriate cleaning solvent and a brush.**
- **Install new seals if it is necessary after having lubricated them with PTFE grease.**
- **Install new parts if it is necessary.**

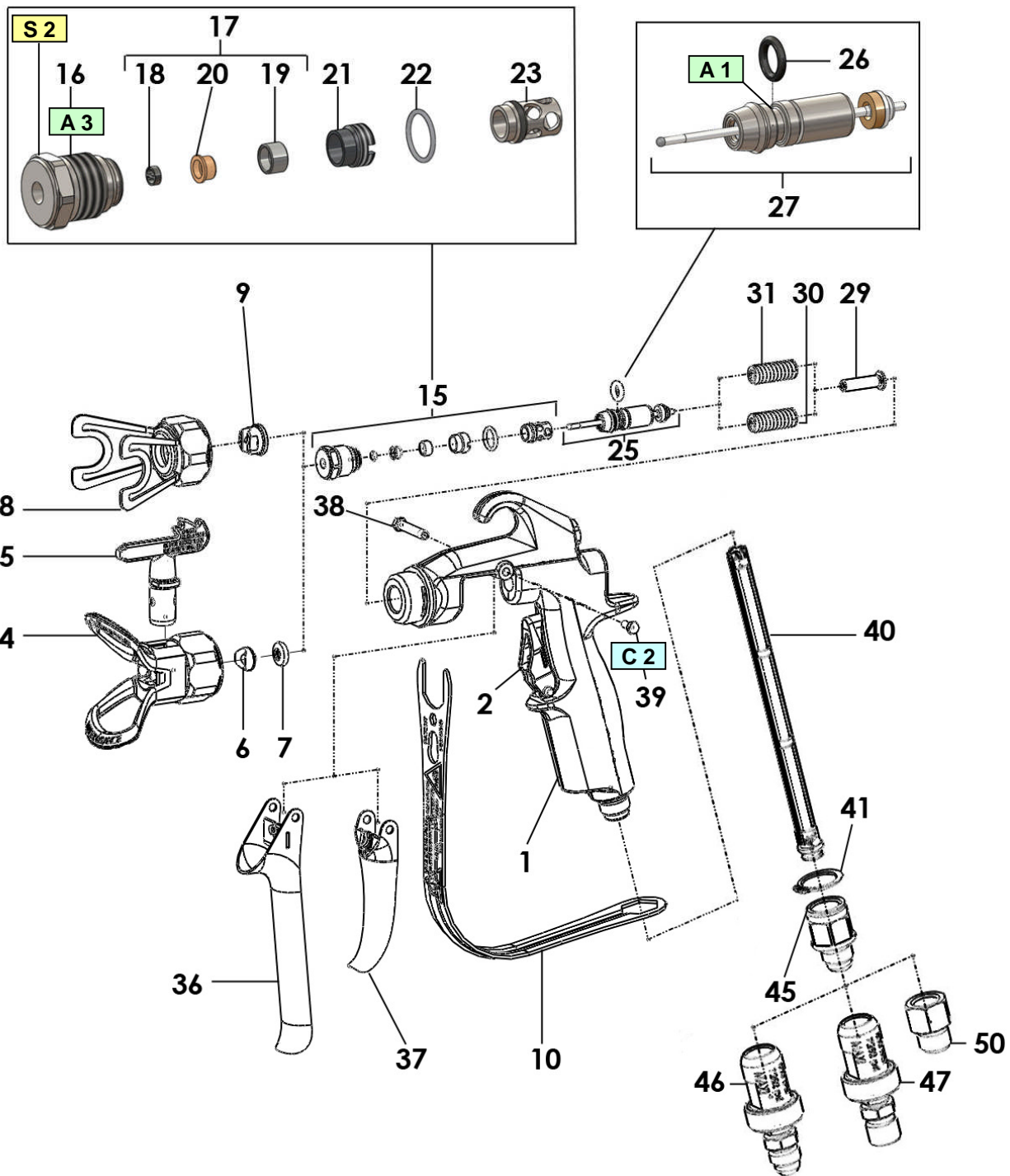

Index	Instructions	Description	Part number
A 1	PTFE grease	PTFE grease (10 ml / 0.0026 US gal)	560.440.101
A 3	Grease (vaseline)	-	-
C 2	Low strength - Anaerobic Adhesive	Loctite 222 (50 ml / 0.013 US gal)	554.180.010
S 1	Torque screwing : 2 Nm / 1.4752 Ft/Lbs		
S 2	Torque screwing : 10 Nm / 7.376 Ft/Lbs		

▪ **SEAT HOLDER ASSEMBLY (IND. 15) REPLACEMENT**

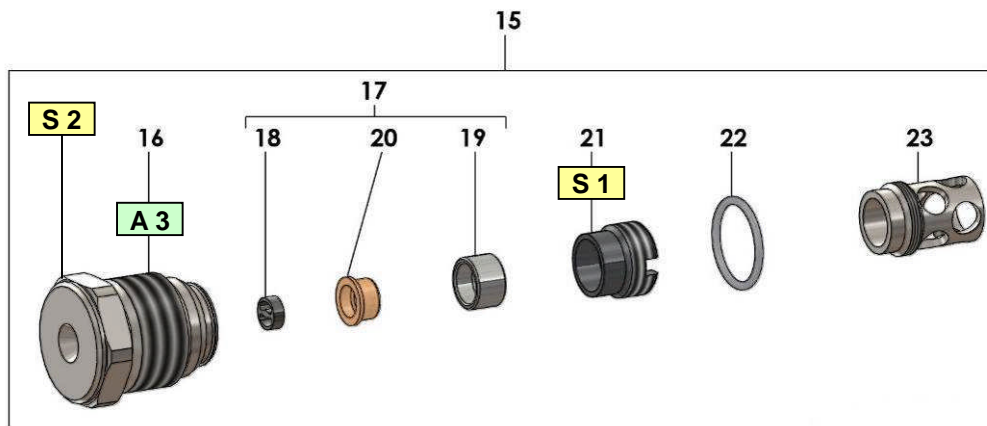

Remove the air cap, then unscrew the seat holder assembly (15) by means of the wrench supplied with the gun.

Loosen the cartridge stop (23) and the screw (21) by means of a screwdriver, take off the seat (19), the PEEK seal (20) and the helicoils (18).

Check parts' and the O-Ring (22) conditions. Change them if necessary.

Reassemble the seat (19), the PEEK seal (20) and the helicoils (18).

Tighten the screw (21) - screwing torque : 2 Nm / 1.4752 Ft/Lbs.

Tighten the cartridge stop (23) manually.

Lubricate the seat holder thread (16) with grease.

Tighten the seat holder (15) in the gun by means of the wrench - screwing torque : 10 Nm / 7.376 Ft/Lbs.

▪ **CARTRIDGE-NEEDLE ASSEMBLY (IND. 25) REPLACEMENT**

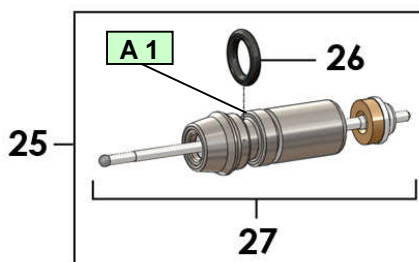

Remove the trigger (36 or 37) by taking off the screw (39) and the trigger spindle (38).

Remove the seat holder (15) as previously indicated.

Remove the cartridge-needle assembly (25) gun frontwards.

If necessary, change the seal (26) or the whole cartridge-needle assembly (25).

Grease the seal (26).

Install the new cartridge-needle assembly frontwards.

When installing the seat holder, the cartridge-needle assembly must abut.

■ **DISASSEMBLY OF THE TIPS**

REVERSING TIPS (IND. 4, 5, 6, 7)

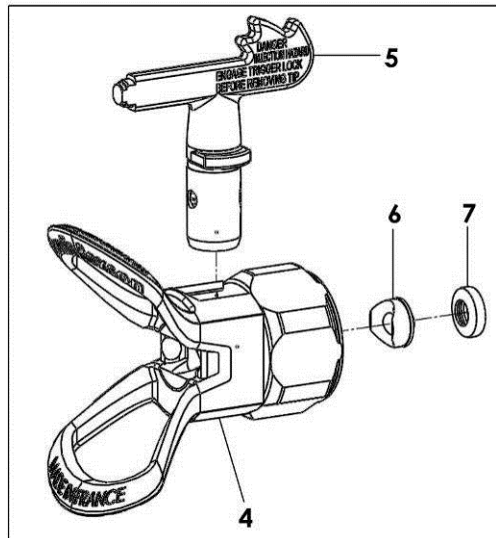

Untighten the head ring.

Pivot the tip at 90 degrees angle from the horizontal axis and remove it upwards.

Remove the seat (6) by using the front part of the handle (5).

Clean and/or change the parts.

Install the seat (6) on the seal (7).

Insert and orientate the seat (6) and the seal (7) by using the front part of the handle (5).

Insert the handle (5) at 90 degree angle from the horizontal axis then pivot (flame downwards).

Install on the gun and tighten the head ring.

FLAT TIPS (IND. 8, 9)

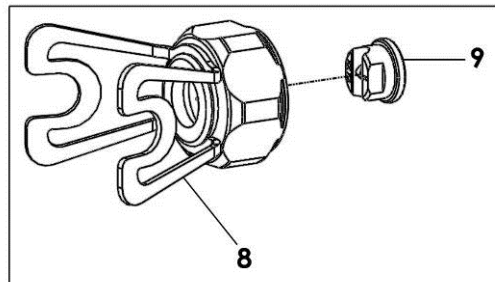

Untighten the head ring.

Remove the tip (9) from the base (8).

Clean and/or change the parts.

Reinstall the parts in the reverse order of the disassembly sequence.

Doc. 573.459.050 Date/Datum/Fecha : 07/06/17 Annule/Cancel/Ersetzt/Anula : 03/10/16	Modif. / Änderung : Kremlin Rexson → Sames Kremlin + Ind. / Pos. 20, 55, 63 Ind. / Pos. 28 supprimé / canceled / annulliert / suprimido	Pièces de rechange Spare parts list Ersatzteilliste Piezas de repuesto
--	---	---

PISTOLET AIRLESS®	AIRLESS SPRAY GUN	#
AIRLESS® PISTOLE	PISTOLA AIRLESS®	
SFLOW 275 BAR / 3989 PSI		135.740.xxx
SFLOW 450 BAR / 6526 PSI		135.745.xxx

TABLEAU DES CONFIGURATIONS - CONFIGURATION CHART - KONFIGURATION - CUADRO DE LAS CONFIGURACIONES

275 bar / 3989 psi			
1/2 JIC	1/4 NPSM	1/2 JIC	1/4 NPSM
135 740 200	135 740 240	135 740 400	135 740 440
135 740 225	135 740 245	135 740 427	135 740 447

<p style="text-align: center;">135 74x xxx</p> <div style="border: 1px solid black; padding: 5px; margin-bottom: 10px;"> 0 = 275 bar / 3989 psi 5 = 450 bar / 6526 psi </div> <div style="border: 1px solid black; padding: 5px; margin-bottom: 10px;"> 2 = 2 doigts / 2 fingers / 2 Finger / 2 dedos 4 = 4 doigts / 4 fingers / 4 Finger / 4 dedos </div> <div style="border: 1px solid black; padding: 5px;"> 0 = sans raccord / without fitting / ohne Nippel / sin racor 2 = avec raccord tournant / with swivel fitting / mit Drehgelenk / con racor giratorio - 1/2 JIC 4 = avec raccord tournant / with swivel fitting / mit Drehgelenk / con racor giratorio - 1/4 NPSM </div>	<div style="border: 1px solid black; padding: 5px; margin-bottom: 10px;"> 0 = Embase pour buse plate / Base for flat tip / Aufnahme für Standard-Düsen / Base para boquilla plana 5 = Embase pour buse réversible / Base for reversing tip / Aufnahme für Wendedüse / Base para boquilla reversible - 515 (12-13) 7 = Embase pour buse réversible / Base for reversing tip / Aufnahme für Wendedüse / Base para boquilla reversible - 517 (14-13) 9 = Embase pour buse réversible / Base for reversing tip / Aufnahme für Wendedüse / Base para boquilla reversible - 519 (18-13) </div>								
	450 bar / 6526 psi								
	<table border="1" style="width: 100%; border-collapse: collapse;"> <tr> <td style="width: 50%;">135 745 420</td> <td style="width: 50%;">135 745 440</td> </tr> <tr> <td></td> <td></td> </tr> <tr> <td>135 745 429</td> <td>135 745 449</td> </tr> <tr> <td></td> <td></td> </tr> </table>	135 745 420	135 745 440			135 745 429	135 745 449		
135 745 420	135 745 440								
135 745 429	135 745 449								

Pièces communes - Common parts - Gleiche Teile - Partes comunes

Ind	#	Désignation	Description	Bezeichnung	Denominación	Qté
1	NC / NS	Corps pistolet avec insert inox	Gun body with stainless steel insert	Pistolenkörper mit Edelstahlinsert	Cuerpo pistola con inserto de inox	1
*2	129 740 906	Levier de sécurité avec goupille	Safety lever with pin	Sicherungshebel mit Splint	Leva de seguridad con pasador	1
10	129 740 020	Protection de main	Trigger protection	Schutz für Abzugshebel	Protección gatillo	1
*15	129 740 040	Porte siège assemblé	Seat holder assembly	Düsennadelsitz Einheit	Porta asiento equipado	1
16	NC / NS	▪ Porte siège	▪ Seat holder	▪ Düsennadelsitz	▪ Porta asiento	1
*17	129 740 908	▪ Siège avec joint PEEK (x 2)	▪ Seat with PEEK seal (x 2)	▪ Einsatz mit Dichtung - PEEK (2 St.)	▪ Asiento con junta, PEEK (x 2)	1
18	NC / NS	▪ ▪ Pastille	▪ ▪ Helicoils	▪ ▪ Begrenzer	▪ ▪ Helicoil	1
19	NC / NS	▪ ▪ Siège	▪ ▪ Seat	▪ ▪ Sitz	▪ ▪ Asiento	1
20	NC / NS	▪ ▪ Joint PEEK	▪ ▪ PEEK seal	▪ ▪ Dichtung-PEEK	▪ ▪ Junta PEEK	1
21	029 600 106	▪ Vis	▪ Screw	▪ Schraube	▪ Tornillo	1
*22	150 040 341	▪ Joint torique (x 10)	▪ O-Ring (x 10)	▪ O-Ring (10 St.)	▪ Junta tórica (x 10)	1
23	129 740 045	▪ Butée de cartouche (x 5)	▪ Cartridge stop (x 5)	▪ Anschlag für Packung (5 St.)	▪ Tope de cartucho (x 5)	1
*25	129 740 050	Ligne pointeau-cartouche	Cartridge-needle assembly	Farbnadel mit Packung komplett	Conjunto aguja-cartucho	1
*26	109 420 298	▪ Joint de cartouche en FKM (x 10)	▪ Seal cartridge, FKM (x 10)	▪ Packungs O-Ring, FKM (10 St.)	▪ Junta de cartucho, FKM (x 10)	1
27	NC / NS	▪ Cartouche et pointeau	▪ Cartridge and needle	▪ Packung und Farbnadel	▪ Cartucho y aguja	1
29	129 740 022	Butée de fin de course (x 5)	Stroke-end stop (x 5)	Anschlag Hubende (5 St.)	Tope de fin de carrera (bolsa de 5)	1
*-	129 740 903	Axe de gâchette + vis (pochette de 5)	Spindle, trigger + screw (pack of 5)	Abzugsachse + Schraube (5 St.)	Eje de gatillo + tornillo (bolsa de 5)	1
38	NC / NS	▪ Axe de gâchette	▪ Spindle, trigger	▪ Abzugsachse	▪ Eje de gatillo	1
39	NC / NS	▪ Vis	▪ Screw	▪ Schraube	▪ Tornillo	1
*40	129 740 183	Filtre Airless® (100 mesh) PA (x 4) (voir accessoires)	Airless filter (100 mesh / 140 µ) PA (x 4) (refer to accessories)	Airless Filter (100 mesh) PA (4 St.) (siehe Zubehör)	Filtro Airless® (100 mesh) PA (x 4) (consultar accesorios)	1
41	102 202 116	Circlips Ø 17 (x 5)	Ring Ø 17 (x 5)	Sicherungsring Ø 17 (St. 5)	Anillo truarc Ø 17 (x 5)	1
45	129 740 021	Raccord de crosse 1/2 JIC	Handle fitting, model 1/2 JIC	Nippel, Materialeingang, 1/2 JIC	Racor de empuñadura, tipo 1/2 JIC	1

Pièces spécifiques - Specific parts - Spezifische Teile - Partes específicas

Ind	#	Désignation	Description	Bezeichnung	Denominación	Qté
4	-	Embase Airless® pour buse réversible (voir accessoires)	Airless base for reversing tip (refer to accessories)	Airless Aufnahme für Wende-Düse (siehe Zubehör)	Base Airless® para boquilla reversible (consultar accesorios)	1
5+6 +7	-	Buse Airless® réversible + siège + joint de buse (voir accessoires)	Reversing Airless tip + seat + seal tip (refer to accessories)	Airless Wende-Düse + Sitz + Düsendichtung (siehe Zubehör)	Boquilla Airless® reversible + asiento + junta de boquilla (consultar accesorios)	1
8	-	Embase Airless® pour buse plate (voir accessoires)	Airless base for flat tip (refer to accessories)	Airless Aufnahme für Standard-Düsen (siehe Zubehör)	Base Airless® para boquilla plana (consultar accesorios)	1
9	-	Buse plate Airless® (voir accessoires)	Flat airless tip (refer to accessories)	Airless Flachstrahl-Düse (siehe Zubehör)	Boquilla plana Airless® (consultar accesorios)	1
36	129 740 007	Gâchette 4 doigts	Trigger, 4 fingers	4 Finger Abzugshebel	Gatillo 4 dedos	1
37	129 740 006	Gâchette 2 doigts	Trigger, 2 fingers	2 Finger Abzugshebel	Gatillo 2 dedos	1
46	129 670 405	Raccord tournant F 1/2 JIC - M 1/2 JIC	Swivel fitting, model F 1/2 JIC - M 1/2 JIC	Drehgelenk IG 1/2 JIC - AG 1/2 JIC	Racor giratorio, tipo H 1/2 JIC - M 1/2 JIC	1
47	129 670 415	Raccord tournant F 1/2 JIC - M 1/4 NPSM	Swivel fitting, model F 1/2 JIC - M 1/4 NPSM	Drehgelenk IG 1/2 JIC - AG 1/4 NPSM	Racor giratorio, tipo H 1/2 JIC - M 1/4 NPSM	1
50	050 123 304	Raccord F 1/2 JIC - M 1/4 NPSM	Fitting, model F 1/2 JIC - M 1/4 NPSM	Nippel, Materialeingang, IG 1/2 JIC - AG 1/4 NPSM	Racor, tipo H 1/2 JIC - M 1/4 NPSM	1

Mod. SFLOW 275 bar / 3989 psi

Ind	#	Désignation	Description	Bezeichnung	Denominación	Qté
30	129 740 904	Ressort gris (x 5)	Grey spring (x 5)	Feder, grau (5 St.)	Muelle gris (x 5)	1

Mod. SFLOW 450 bar / 6526 psi

Ind	#	Désignation	Description	Bezeichnung	Denominación	Qté
31	129 740 905	Ressort rouge (x 5)	Red spring (x 5)	Feder, rot (5 St.)	Muelle rojo (x 5)	1

POCHETTES - KITS - SÄTZE - BOLSAS

Mod. SFLOW 275 bar / 3989 psi

Ind	#	Désignation	Description	Bezeichnung	Denominación	Qté
*	129 740 901	Pochette de maintenance - Porte siège + pointeau + ressort (ind. 15, 25, 29, 30)	Servicing kit - Seat holder + needle + spring (ind. 15, 25, 29, 30)	Servicekit - Düsennadelsitz, Farbnadel und Feder (Pos. 15, 25, 29, 30)	Bolsa de reparación - Porta asiento, aguja + muelle (ind. 15, 25, 29, 30)	1

Mod. SFLOW 450 bar / 6526 psi

Ind	#	Désignation	Description	Bezeichnung	Denominación	Qté
*	129 740 902	Pochette de maintenance - Porte siège + pointeau + ressort (ind. 15, 25, 29, 31)	Servicing kit - Seat holder + needle + spring (ind. 15, 25, 29, 31)	Servicekit - Düsennadelsitz, Farbnadel und Feder (Pos. 15, 25, 29, 31)	Bolsa de reparación - Porta asiento, aguja + muelle (ind. 15, 25, 29, 31)	1

BUSES REVERSIBLES - REVERSING TIPS - WENDEDÜSEN - BOQUILLAS REVERSIBLES

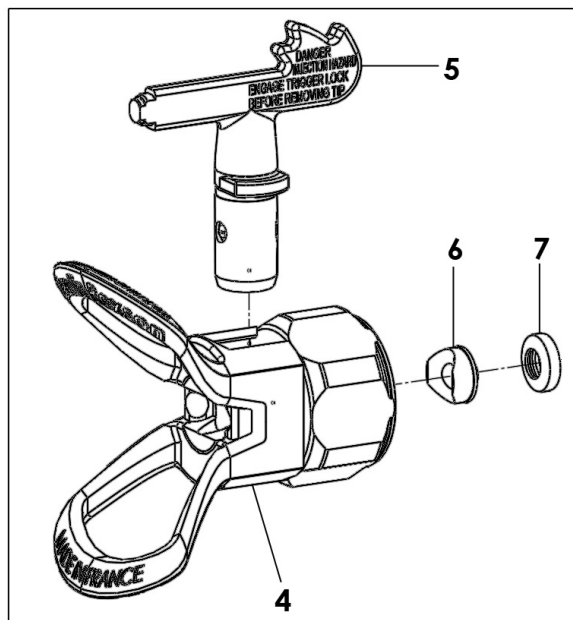

Ind	#	Désignation	Description	Bezeichnung	Denominación	Qté
4	132 740 200	Bague Airless® pour buse réversible TIP TOP (voir doc. 573.148.080)	Airless manifold for reversing TIP TOP (refer to Doc. 573.148.080)	Airless O-Ring für Wende-Düse TIP TOP (Siehe Dok. 573.148.080)	Anillo Airless® para boquilla reversible TIP TOP (consultar Doc. 573.148.080)	1
5+6 +7	000 40x xxx	Buse Airless® réversible TIP TOP + siège + joint de buse	Reversing Airless TIP TOP + seat + seal tip	Airless Wende-Düse TIP TOP + Sitz + Düsendichtung	Boquilla Airless® reversible TIP TOP + asiento + junta de boquilla	1
*7	134 740 007	Joint de buse réversible (x 10)	Reversing seal tip (x 10)	Düsendichtung (10 St.)	Junta de boquilla reversible (x 10)	1

Ind	#	Désignation	Description	Bezeichnung	Denominación	Qté
*	129 740 907	Pochette de maintenance - siège + joint de buse (ind. 6 (x 4), 7 (x 4))	Servicing kit - seat + seal tip (ind. 6 (x 4), 7 (x 4))	Servicekit - Sitz + Düsendichtung (Pos. 6 (4 St.), 7 (4 St.))	Bolsa de reparación - asiento + junta de boquilla (ind. 6 (x 4), 7 (x 4))	1

TABLEAU - CHART - TABELLE - CUADRO
BUSES REVERSIBLES - REVERSING TIPS - WENDEDÜSEN - BOQUILLAS REVERSIBLES

Largeur de jet / Fan width / Strahlbreite / Anchura abanico		→	6.5 / 8.5 cm	10 / 12 cm	12 / 16 cm	17 / 21 cm	22 / 24.5 cm	25 / 29 cm	29 / 33 cm	33 / 37 cm	38 / 44 cm	48 / 56 cm	
Angle / Winkel / Abanico		→	17°	25°	30°	40°	50°	60°	70°	80°	90°	95°	
Débit eau Water flow rate Wasserdurchsatz Caudal agua (l/mn) 70 bar / 1.015 psi	Ø (pouce ")	XX-03	1XX XX-05	2XX XX-07	3XX XX-09	4XX XX-11	5XX XX-13	6XX XX-15	7XX XX-17	8XX XX-19	9XX XX-21	Débit eau Water flow rate Wasserdurchsatz Caudal agua (l/mn) 138 bar / 2.2002 psi	
	Calibre Size Grösse												
0.22 l/mn	0.009 04				309 04-09	409 04-11	509 04-13						0.33 l/mn
0.33 l/mn	0.011 06			211 06-07	311 06-09	411 06-11	511 06-13	611 06-15					0.49 l/mn
0.45 l/mn	0.013 09			213 09-07	313 09-09	413 09-11	513 09-13	613 09-15	713 09-17				0.69 l/mn
0.60 l/mn	0.015 12			215 12-07	315 12-09	415 12-11	515 12-13	615 12-15	715 12-17				0.91 l/mn
0.72 l/mn	0.017 14			217 14-07	317 14-09	417 14-11	517 14-13	617 14-15	717 14-17	817 14-19			1.17 l/mn
0.95 l/mn	0.019 18			219 18-07	319 18-09	419 18-11	519 18-13	619 18-15	719 18-17	819 18-19			1.47 l/mn
1.33 l/mn	0.021 25					421 25-11	521 25-13	621 25-15	721 25-17	821 25-19			1.79 l/mn
1.6 l/mn	0.023 30					423 30-11	523 30-13	623 30-15	723 30-17	823 30-19			2.15 l/mn
2.175 l/mn	0.025 40					425 40-11	525 40-13	625 40-15	725 40-17	825 40-19			2.54 l/mn
2.38 l/m	0.029 45				329 45-09	429 45-11	529 45-13	629 45-15	729 45-17	829 45-19			3.42 l/mn
3.78 l/mn	0.033 68					433 68-11	533 68-13	633 68-15	733 68-17	833 68-19			4.42 l/mn
5.6 l/mn	0.036 100						539 100-13	639 100-15	739 100-17	839 100-19			6.2 l/mn

Pour établir la référence d'une buse, remplacer les croix par le nombre repère de la buse précédé de 000.4XX.XXX
 Exemple : pour commander une buse 25.13, utiliser la référence : 000 402 513

To obtain tip part number, replace the crosses by the engraved tip number preceded by 000.4XX.XXX
 Example : use part number 000 402 513 to obtain tip 25.13

Die Bestell-Nr. für eine Wendedüse erhält man, indem man die Kreuze durch die vorgenannte Kennzahl ersetzt : 000.4XX.XXX
 Beispiel : für eine Düse 25.13 ergibt sich die Bestell-Nr. : 000 402 513

Para establecer la referencia de una boquilla reemplazar las cruces por el número de la boquilla precedido por 000.4XX.XXX
 ejemplo : para pedir una boquilla 25.13 emplear la referencia : 000 402 513

**TABLEAU - CHART - TABELLE - CUADRO
BUSES PLATES - FLAT TIPS - STANDARD-DÜSEN - BOQUILLAS PLANAS**

Largeur de jet / Fan width / Strahlbreite / Anchura abanico		→	6.5 / 8.5 cm	10 / 12 cm	12 / 16 cm	17 / 21 cm	22 / 24.5 cm	25 / 29 cm	29 / 33 cm	33 / 37 cm	38 / 44 cm	48 / 56 cm
Angle / Winkel / Abanico		→	17°	25°	30°	40°	50°	60°	70°	80°	90°	95°
Débit eau Water flow rate Wasser- durchsatz Caudal agua (l/mn) 70 bar / 1.015 psi	Ø (pouce ")	XX-03	1XX XX-05	2XX XX-07	3XX XX-09	4XX XX-11	5XX XX-13	6XX XX-15	7XX XX-17	8XX XX-19	9XX XX-21	Débit eau Water flow rate Wasser- durchsatz Caudal agua (l/mn) 138 bar / 2.002 psi
	Calibre Size Grösse											
0.15 l/mn	0.007 03	03-03	03-05	03-07								0.20 l/mn
0.22 l/mn	0.009 04	04-03	04-05	04-07	04-09	04-11	04-13					0.33 l/mn
0.33 l/mn	0.011 06	06-03	06-05	06-07	06-09	06-11	06-13	06-15				0.49 l/mn
0.45 l/mn	0.013 09	09-03	09-05	09-07	09-09	09-11	09-13	09-15	09-17			0.69 l/mn
0.60 l/mn	0.015 12			12-07	12-09	12-11	12-13	12-15	12-17			0.91 l/mn
0.72 l/mn	0.017 14	14-03	14-05	14-07	14-09	14-11	14-13	14-15	14-17	14-19		1.17 l/mn
0.95 l/mn	0.019 18			18-07	18-09	18-11	18-13	18-15	18-17	18-19		1.47 l/mn
1.06 l/mn	0.020 20		20-05	20-07	20-09	20-11	20-13	20-15	20-17	20-19		1.56 l/mn
1.33 l/mn	0.021 25					25-11	25-13	25-15	25-17	25-19		1.79 l/mn
1.6 l/mn	0.023 30			30-07	30-09	30-11	30-13	30-15	30-17	30-19		2.15 l/mn
2.175 l/mn	0.025 40					40-11	40-13	40-15	40-17	40-19		2.54 l/mn
2.38 l/m	0.029 45			45-07		45-11	45-13	45-15	45-17	45-19	45-21	3.42 l/mn
3.78 l/mn	0.033 68					68-11	68-13	68-15	68-17	68-19		4.42 l/mn

Les buses plates garantissent une grande précision dans leurs performances.
Pour établir la référence d'une buse, remplacer les croix par le nombre gravé sur la buse précédé de 000.00X.XXX
Exemple : pour commander une buse 25.13, utiliser la référence : 000 002 513.

Flat tips guaranty a very high precision in performance.
To obtain tip part number, replace the crosses by the number engraved on the tip preceded by 000.00X.XXX
Example : use part number 000 002 513 to obtain tip 25.13.

Die Flachstrahl-Düsen garantieren eine hohe Spritzstrahlpräzision.
Die X durch die auf der Düse gravierte Nummer ersetzen Bestell-Nr. 000.00X.XXX
Beispiel : für eine Düse 25.13 ergibt sich die Bestell-Nr. : 000 002 513.

Las boquillas planas garantizan una gran precisión de resultados.
Para establecer la referencia de una boquilla reemplazar las cruces por el número de la boquilla precedido por 000.00X.XXX
Ejemplo : para pedir una boquilla 25.13 emplear la referencia : 000 002 513

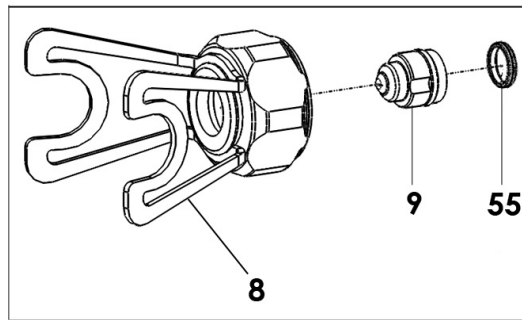

Ind	#	Désignation	Description	Bezeichnung	Denominación	Qté
8	132 740 100	Embase Airless® pour buse plate	Airless base for flat tip	Aufnahme für Standard Airless-Düsen	Base Airless® para boquilla plana	1
9	000 00x xxx	Buse plate Airless®	Flat airless tip	Airless Flachstrahl-Düse	Boquilla plana Airless®	1
55	150 041 319	Joint pour buse plate plate (x 5)	Seal for flat tip (x 5)	Dichtung für Standard Airless-Düsen (5 St.)	Junta para boquilla plana (x 5)	1

**FILTRE A LA CROSSE - GUN FILTER - SIEBE FÜR PISTOLENFILTER - FILTRO A LA EMPUÑADURA
(x 4)**

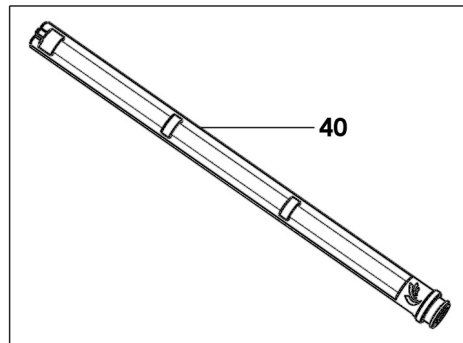

Ind	#	Matière - Material - Materia	Calibre - Mesh - Feinheit	Couleur - Color	Buse - Tip - Düse - Boquilla	Qté
40	129 740 081	Inox / Stainless steel / Edelstahl	200 mesh / 74µ	Rouge / Red / Rot / Rojo	04-XX → 06-XX	1
	129 740 181	PA				1
	129 740 082	Inox / Stainless steel / Edelstahl	150 mesh / 100µ	Bleu / Blue / Blau / Azul	06-XX → 12-XX	1
	129 740 182	PA				1
	129 740 083	Inox / Stainless steel / Edelstahl	100 mesh / 149µ	Jaune / Yellow / Gelb / Amarillo	12-XX → 18-XX	1
	129 740 183	PA				1
	129 740 084	Inox / Stainless steel / Edelstahl	50 mesh / 300µ	Blanc / White / Weiß / Blanco	18-XX → 100-XX	1
	129 740 184	PA				1

OPTION - ON REQUEST - OPTIONEN - OPCIÓN

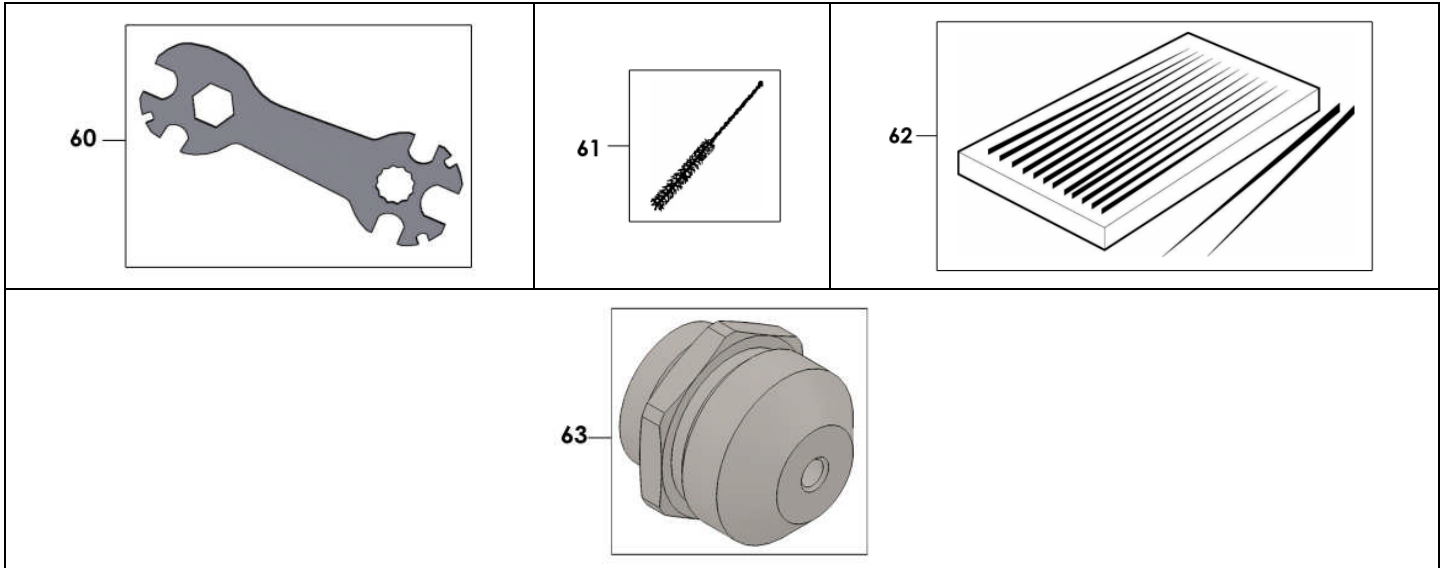

Ind	#	Désignation	Description	Bezeichnung	Denominación	Qté
60	049 030 042	Clé plate	Gun wrench	Pistolenschlüssel	Llave para pistola	1
61	906 300 101	Goupillon	Large size brush	Pistolenreinigungsbürste	Cepillo grande	1
62		Aiguilles de débouchage (x 12) pour buses :	Unclogging needles (x 12) for tips :	Düsenreinigungs-Nadeln (12 St.) für Düsen :	Agujas desobturadoras (x 12) para boquillas :	
	000 094 000	de 06 à 09	size 06 to 09	Von 06 bis 09	De 06 a 09	1
	000 094 002	> 09	size > 09	ab > 09	> 09	1
63	129 740 074	Diaphragme 060 M 25 x 175 pour embase Airless® Sflow pour buse réversible	Diaphragm, model 060 M 25 x 175 for SFlow Airless base for reversing tip	Vorzerstäuber Typ 060 M 25 x 1,75 für Airless SFlow für Wendedüse	Restrictor 060 M 25 x 175 para base Airless® Sflow para boquilla reversible	1

* Pièces de maintenance préconisées.

* Preceding the index number denotes a suggested spare part.

* Bezeichnete Teile sind empfohlene Ersatzteile.

* Piezas de mantenimiento preventivas.

N C : Non commercialisé.

N S : Denotes parts are not serviceable.

N S : Bezeichnete Teile gibt es nicht einzeln, sondern nur komplett .

N S : no suministrado.



AIRLESS MANUAL GUN

PREVENTIVE MAINTENANCE

TRANSLATION FROM THE ORIGINAL MANUAL

IMPORTANT : Before assembly and start-up, please read and clearly understand all the documents relating to this equipment (professional use only).

THE PICTURES AND DRAWINGS ARE NON CONTRACTUAL. WE RESERVE THE RIGHT TO MAKE CHANGES WITHOUT PRIOR NOTICE.

SAMES KREMLIN SAS
13, chemin de Malacher
38 240 - MEYLAN - France
☎ : 33 (0)4 76 41 60 60

www.sames-kremlin.com



In order to protect the operator, protective clothing (gloves, respirator mask, glasses, hearing protective earplug, clothes...) are required.

Use the equipment in a properly ventilated area.

This spray gun is a precision tool. Its correct functioning requires regular maintenance, carried out with care. When it is carried out directly after use, the cleaning of the gun is faster and easier.

➔ **Never use metallic brushes, files or pliers when dismantling the gun.**

▪ **SHORT DURATION SHUTDOWN (LESS THAN 3 HOURS)**

Leave the equipment as it is. In any case, if the tip becomes a little clogged with material, it is best to clean it with a brush and some solvent.

▪ **LONG DURATION SHUTDOWN**

Shut off gun air and fluid supply.

Change material with solvent and trigger the gun to depressurize the hoses and flush the pump, the hoses and the gun.

Unscrew the aircap ring to remove the reversing tip or the flat tip. Put it in the solvent to soak and then brush it clean. Remove the seat holder. Remove the needle gun frontwards. Soak the tip. Brush it. Clean inside the gun with a brush and solvent. Insist particularly on threads.

Flush the gun.

➔ **Never soak the gun itself in solvent.**

➔ **Use only products or solvent compatible with the parts in contact with the material (refer to data sheet of the material manufacturer).**



AIRLESS MANUAL GUN

TROUBLESHOOTING GUIDE

TRANSLATION FROM THE ORIGINAL MANUAL

IMPORTANT : Before assembly and start-up, please read and clearly understand all the documents relating to this equipment (professional use only).

THE PICTURES AND DRAWINGS ARE NON CONTRACTUAL. WE RESERVE THE RIGHT TO MAKE CHANGES WITHOUT PRIOR NOTICE.

SAMES KREMLIN SAS
13, chemin de Malacher
38 240 - MEYLAN - France
 : 33 (0)4 76 41 60 60

www.sames-kremlin.com

The spraying quality depends directly on the shape of the tip. It is recommended to replace it regularly to get a constant fan pattern.

A premature wearing deforms the tip and leads to two troubles :

- fan pattern reduced and charged at the center,
- a higher output.

TROUBLE	CAUSE	SOLUTION
Material is no longer coming out of the gun	Clogged tip	Check gun material supply. For the reversible tip, pivot the tip at 180 degree to unclog it.
Low flow rate	Filter partially clogged (if there is one)	If no improvement : shut off the pump pressure. Depressurize the hoses. Remove and clean the flat tip or the reversible tip and the filter. Change the filter if necessary.
Spray fan is not uniform	Tip partially clogged	For the reversible tip, pivot the tip at 180 degree to unclog it. If no improvement : remove it and change it. For the flat tip, remove it and change it.
	Unappropriate tip	Use an appropriate tip size
	Worn tip	Change tip
	Fluid cannot be sprayed	Increase pump supply air pressure
	Material viscosity too high	Reduce viscosity
Fluid leak	Bad tightness between the needle ball and its seat	Clean the seat or replace the needle and the seat
	Worn cartridge	Replace the cartridge
	Handle fitting loose or defective	Tighten the handle fitting or change it
	Seat holder loose or defective	Tighten the seat holder or change it
	Defective reversible tip seal	Change it
	Defective seat	Change it
	Head ring not correctly tightened	Tighten it



AIRLESS MANUAL GUN

OPERATING, START-UP AND HANDLING

TRANSLATION FROM THE ORIGINAL MANUAL

IMPORTANT : Before assembly and start-up, please read and clearly understand all the documents relating to this equipment (professional use only).

THE PICTURES AND DRAWINGS ARE NON CONTRACTUAL. WE RESERVE THE RIGHT TO MAKE CHANGES WITHOUT PRIOR NOTICE.

SAMES KREMLIN SAS
13, chemin de Malacher
38 240 - MEYLAN - France
☎ : 33 (0)4 76 41 60 60

www.sames-kremlin.com

1. OPERATING PRINCIPLE

The AIRLESS spraying enables to make material flow through a tip, at high pressure without any atomizing air.

The gun is supplied with material by means of only one hose.

To optimize the spraying, the following parameters are requested : viscosity, charges, materials pressure, tip size.

The gun is supplied with a material needle that controls the opening and the closing of the seat when triggering the gun.

The fan pattern depends only of the tip :

- with flat tips, you obtain a very fine and regular fan,
- with reversing tips, the unclogging is easier.

The fluid is drawn by the AIRLESS pump into the container and forced under pressure via the hose, towards the gun.

2. START-UP



Safety instructions :

- Never try to stop the spray fan with any part of the body (hands, fingers...) or with rags. Never point the spray gun at anyone or at any part of the body.
- The operator will need medical attention if the high pressure material spray is in contact with the body (eyes, fingers...).
- **Always depressurize air and hoses** before carrying out any servicing on the gun.



In order to protect the operator, protective clothing (gloves, respirator mask, glasses, hearing protective earplug, clothes...) are required.

Use the equipment in a properly ventilated area.

- 1- Trigger the gun.
- 2- Connect the material hose between the gun and the pump material outlet.
- 3- Ground the pump.
- 4- Interconnect the air equipment with the air pressure network (clean air - maximum 6 bar / 87 psi). Install a filter, if necessary.
- 5- Connect all the hoses.

▪ FLUSHING WITH SOLVENT

- 6- Insert the suction rod into the solvent filled container.
- 7- Increase the pressure so that the solvent hose out from the suction rod.
- 8- Point the gun towards the container, unlock and trigger the spray gun.
- 9- Increase **progressively** the air regulator so that the pump runs slowly. Trigger the gun until the material flows out regularly.

▪ **PRIMING WITH MATERIAL**

10- Remove the suction rod from the solvent filled container and immerse it into the material container.

11- Point the gun towards the material container and trigger the gun until the material flows out regularly.

▪ **WORK**

12- Unlock the trigger gun to install the flat tip or the reversing tip depending upon your work. (Please to select the tip, refer to the tip chart).

13- Adjust the regulator to obtain the required pressure and material flow rate.

3. GUN HANDLING

Keep the gun perpendicular to the surface to be painted. Avoid working with the wrist. Do not forget that crossed sweeps cannot correct irregularities.

Spraying from a stationary gun will not give you even coverage. Start the pass and trigger just before the leading edge. Release the trigger before the pass ends, just after the trailing edge of the object.

Make sure that overlapping spray passes are even and regular.

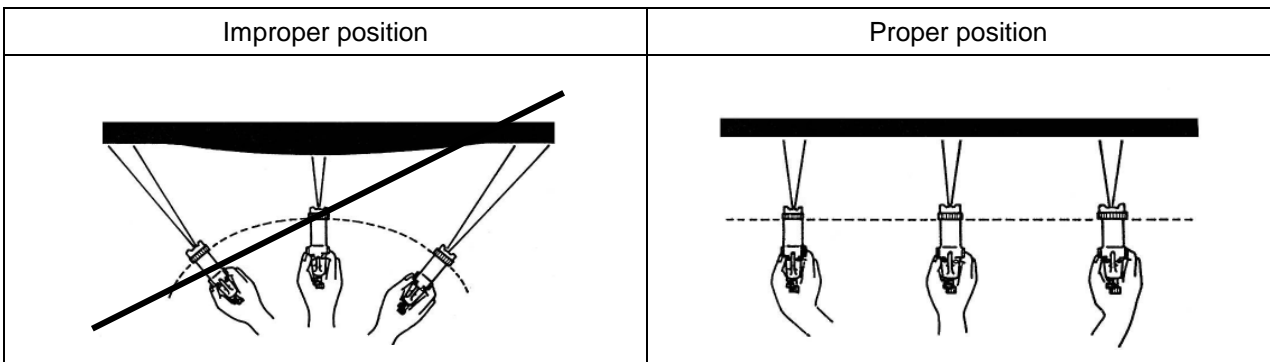

4. SHUTDOWN AT THE END OF THE WORK

▪ SHORT DURATION SHUTDOWN

- 1- Decrease the regulator pressure until reading **0 bar / 0 psi** on the gauge.
- 2- Trigger the spray gun to depressurize the system.
- 3- Lock the gun trigger.
- 4- Remove the flat tip or the reversing tip and soak it into solvent.

▪ LONG DURATION SHUTDOWN

- 1- Decrease the regulator pressure until reading **1 bar / 14.503 psi** on the gauge.
- 2- Remove the flat tip or the reversing tip and soak it into solvent.
- 3- Remove the suction rod from the material container and soak it into solvent.
- 4- Point the spray gun towards the material container and trigger the gun. When the material flows out, point the spray gun towards the solvent container.
- 5- When the solvent flows out, release the gun trigger.

Nota : release the gun trigger when the pump piston is in low position. To prevent from damaging the seals when starting the pump, the piston must be immersed into solvent.

- 6- Fully unscrew the air regulator.
- 7- Press the gun trigger to decompress the hoses.



AIRLESS MANUAL GUN

SFLOW™

TECHNICAL FEATURES

TRANSLATION FROM THE ORIGINAL MANUAL

IMPORTANT : Before assembly and start-up, please read and clearly understand all the documents relating to the equipment (professional use only).

THE PICTURES AND DRAWINGS ARE NOT CONTRACTUAL. WE RESERVE THE RIGHT TO MAKE CHANGES WITHOUT PRIOR NOTICE.

SAMES KREMLIN SAS
13, chemin de Malacher
38 240 - MEYLAN - France
☎ : 33 (0)4 76 41 60 60

www.sames-kremlin.com

1. DESCRIPTION

The SFLOW™ gun is an AIRLESS manual gun for professional use only.

There are two versions of the gun based upon the working pressure (275 bar / 3989 psi or 450 bar / 6526 psi).

The SFLOW™ gun is a swivel fitting gun.

It is recommended for a wide range of 1K and 2K components, high solid materials, epoxy, Polyurethan, anti-corrosion, anti-fouling. It is also recommended for glazing, finishing enamel, acrylic paint materials, front coatings, latex, expanding materials,....

It is not recommended for wated-based materials.



2. TECHNICAL FEATURES

FEATURES	GUN SFLOW - 275 bar / 3989 psi	GUN SFLOW - 450 bar / 6526 psi
Material supply pressure	Max. 275 bar / 3989 psi	Max. 450 bar / 6526 psi
Fluid flow rate	Depending on tip size (Refer to Doc. 573.459.050 - Spare Parts)	
Weight (gun + air cap + tip)	520 g 570 g (with swivel fitting)	
Maximum operating temperature	50°C / 117° F	
Wetted parts	PA, Aluminium, Stainless steel, PTFE, Carbide, POM	
Seat (removable)	Carbide	
Material fitting	M 1/2 JIC / M 1/4 NPS	
Safety device	Safety lever + tip protection + trigger protection	
Filter	From 50 to 200 mesh / from 300 µ to 74 µ	
Weighted sound pressure (LAeq) (under pressure / with tip, model 18-13)	88.5 dBa	88.6 dBa

3. INSTALLATION

■ DESCRIPTION OF THE LABEL MARKING

Marking in accordance with the ATEX regulation

SAMES KREMLIN FRANCE	Name and address of the manufacturer	
CE  II 2 G	CE : European conformity  : For use in explosive area II : group II 2 : class 2 G : gas Surface equipment meant to an area where explosive atmospheres due to gas, vapours, mists are liable to appear from time to time in usual operating.	On the body
Ex h IIA T6 X	Ex : Marking of conformity with European standards h : Mode of protection for non electrical device IIA : Gas group T6 : Temperature class - Maximum surface temperature : 85°C / 185° F X : Special conditions that apply for a safe use. Refer to instructions listed in the instruction manuals accompanying your purchase.	
Gb	Gb : Equipment protection level (Gas zone1)	
20xx	Marking of the manufacturing year (with 4 characters)	
SFLOW™	Gun model	
P prod : xx bar / xx psi	Maximum fluid pressure	

■ INSTALLATION DIAGRAM

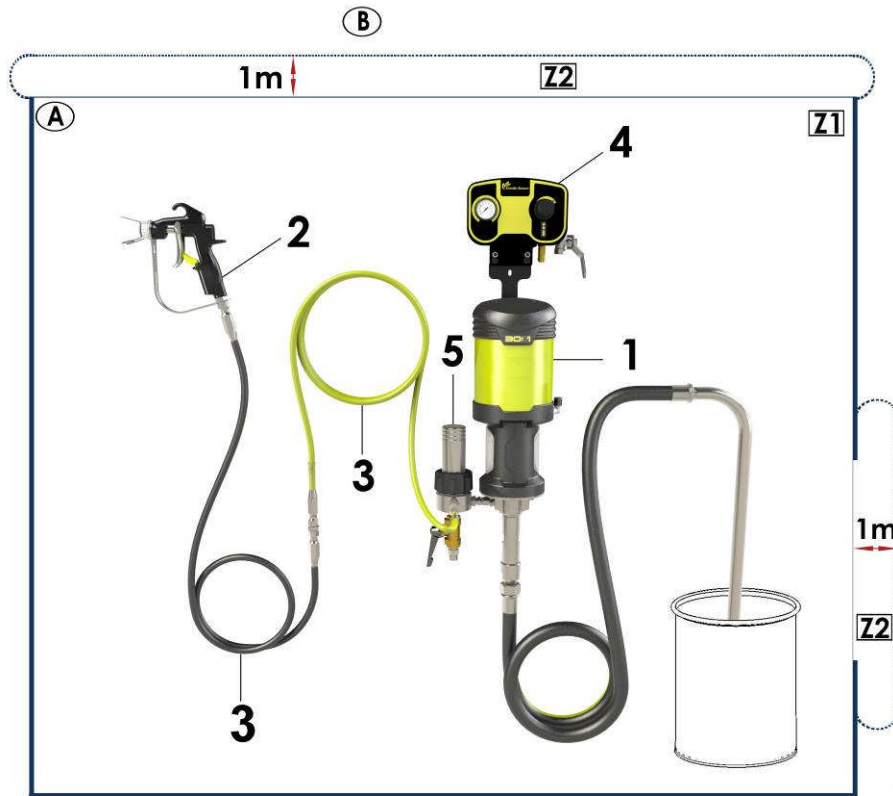

Nota : drawing of an installation with Airless pump, model 30-C25

A	Explosive area : Area 1 (Z1) or area 2 (Z2) : spraybooth
B	Non-explosive area
1	Airless pump
2	Airless gun, model SFLOW™
3	Fluid hose

4	Air supply
5	Fluid filter



The 1 m / 39.37" distance indicated in the diagram is given for information purposes only and hold harmless to SAMES KREMLIN. The user is responsible for the extraction and conditioning of the painting area where the equipment is used, for working conditions (refer to EN 60079-10 standard).

The 1 m / 39.37" distance may be modified if trials carried out by the user deem this necessary.



Nota: Choose the appropriate pump to ensure that the working pressure supplied is suitable for the selected gun.

Please ensure when fitting the **high pressure** paint hose between the gun and the pump that the fittings are firmly tightened.



Nota : The 2 gun fluid hoses must be conductive.