

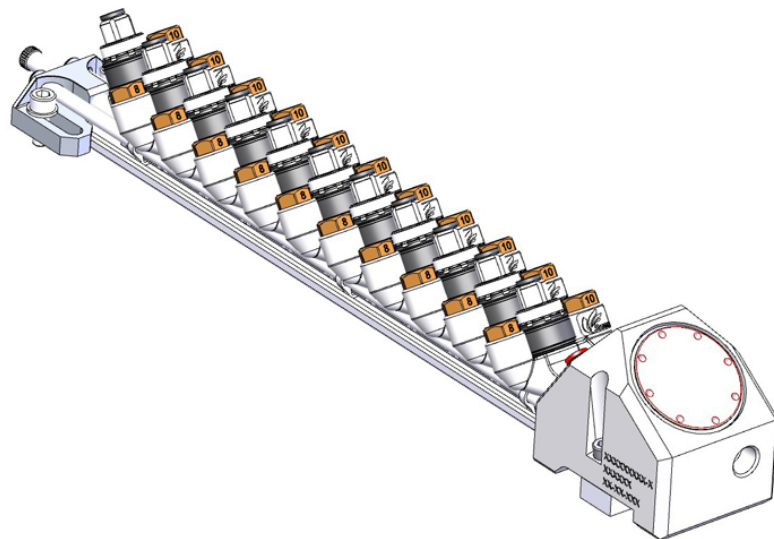

From February 1st, 2017 SAMES Technologies SAS becomes SAMES KREMLIN SAS  
A partir du 1/02/17, SAMES Technologies SAS devient SAMES KREMLIN SAS



# User manual

## UPside CCV Color Change Block

**SAS SAMES Technologies.** 13 Chemin de Malacher -  
Inovallée - CS70086 - 38243 Meylan Cedex France  
Tel. 33 (0)4 76 41 60 60 - Fax. 33 (0)4 76 41 60 90 - [www.sames.com](http://www.sames.com)

All communication or reproduction of this document, in any form whatsoever and all use or communication of its contents are forbidden without express written authorisation from SAMES Technologies.

The descriptions and characteristics mentioned in this document are subject to change without prior notice.

© SAMES Technologies 2014



**WARNING** : SAS Sames Technologies is registered with the Ministry of Labour as a training institution.

Throughout the year, our company offers training courses in the operation and maintenance of your equipment.

A catalogue is available on request. Choose from a wide range of courses to acquire the skills or knowledge that is required to match your production requirements and objectives.

Our training courses can be delivered at your site or in the training centre at our Meylan head office.

Training department:

Tel. 33 (0)4 76 41 60 04

E-mail: [formation-client@sames.com](mailto:formation-client@sames.com)

SAS Sames Technologies operating manuals are written in French and translated into English, German, Spanish, Italian and Portuguese.

The French version is deemed the official text and Sames will not be liable for the translations into other languages.

# UPside CCV Color Change Block

1. Health and Safety Instructions - - - - -	5
1.1. <i>Marking</i> . . . . .	5
1.2. <i>Simplified analysis of the potential sources of ignition according to Standard EN 13463-1</i> . . . . .	5
1.3. <i>Precautions for Use</i> . . . . .	6
1.4. <i>Warnings</i> . . . . .	6
2. Description - - - - -	7
2.1. <i>Presentation of the different modules</i> . . . . .	7
2.1.1. <i>UPside CCV single circuit with regulator</i> . . . . .	8
2.1.2. <i>UPside CCV, type circuit Switch A/B</i> . . . . .	9
2.1.3. <i>UPside CCV circuit in "Turn"</i> . . . . .	10
2.1.4. <i>UPside CCV dual circuit</i> . . . . .	11
2.2. <i>Characteristics</i> . . . . .	12
3. Operating - - - - -	13
4. Tools - - - - -	14
5. Installation - - - - -	17
5.1. <i>Installation of UPside fitting and hose on UPside CCV module</i> . . . . .	17
5.2. <i>Recommendations of installation on air dump assembly</i> . . . . .	18
6. Maintenance - - - - -	19
6.1. <i>Summary table of maintenance operations</i> . . . . .	19
6.2. <i>Preventive Maintenance</i> . . . . .	19
6.2.1. <i>Procedure A: Cleaning of exterior</i> . . . . .	19
6.3. <i>Corrective Maintenance</i> . . . . .	19
6.3.1. <i>Procedure B: Replacement of UPside CCV module</i> . . . . .	19
6.3.2. <i>Procedure C: Replacement of flat seal</i> . . . . .	20
6.3.3. <i>Procedure D: Replacement of the UPvalve</i> . . . . .	21
6.3.4. <i>Procedure E: Replacement of hoses</i> . . . . .	22
6.3.5. <i>Procedure F: Maintenance of regulator</i> . . . . .	23
7. Troubleshooting - - - - -	24
8. Spare parts - - - - -	25
8.1. <i>UPside CCV with return</i> . . . . .	25
8.2. <i>UPside CCV without return</i> . . . . .	26
8.3. <i>UPside CCV, rear closed</i> . . . . .	27
8.3.1. <i>Rinsing open</i> . . . . .	28
8.4. <i>UPside CCV, front closed</i> . . . . .	29
8.5. <i>Accessories</i> . . . . .	30
8.5.1. <i>Regulator block</i> . . . . .	30
8.5.2. <i>Regulator block, 2 sensors</i> . . . . .	31
8.5.3. <i>Shunt pump block</i> . . . . .	33
8.5.4. <i>Rear connection / Dump module</i> . . . . .	33
8.5.5. <i>Selection block</i> . . . . .	34

8.5.6. Shunt regulator block . . . . .	34
8.5.7. Single output support block . . . . .	35
8.5.8. Rear junction block . . . . .	35
8.5.9. Junction union . . . . .	36
8.5.10. Spring for Air dump assembly for circuit in line . . . . .	36
8.5.11. Upside CCV support . . . . .	37
8.6. UPvalves . . . . .	38
8.6.1. Standard Upvalve . . . . .	38
8.6.2. 2K Upvalve with bellow . . . . .	38
8.7. Upside Fittings for UPSide module supply . . . . .	39
8.7.1. Metric fittings . . . . .	39
8.7.2. Imperial fittings. . . . .	40
8.8. Mini rack fitting for UPSide modules . . . . .	41
8.9. Fittings for end modules . . . . .	42
8.10. Check valve for air UPSide CCV module . . . . .	42

## 1. Health and Safety Instructions



**WARNING :** This manual contains links to the following user manual:

- [see RT Nr 6364](#) for the user manual of electrical systems, pressure sensor ([see § 8.5.2.1 page 32](#) Item 1), electrical system TRA1.1.

### 1.1. Marking

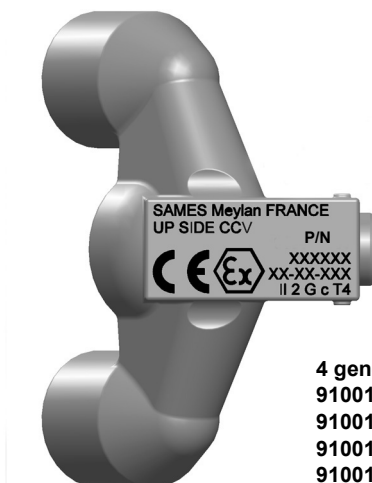

**4 generic part numbers:**

- 910012869:** UPside CCV, module with return
- 910012870:** UPside CCV, module without return
- 910013768:** UPside CCV, rear closed
- 910015723:** UPside CCV, front closed

### 1.2. Simplified analysis of the potential sources of ignition according to Standard EN 13463-1

Risk of ignition		Action applied to prevent any ignition source to become effective
Potential source of ignition	Description / Main cause (What are the conditions engendering the ignition risk?)	Description of the applied action
Hot surface	Warm-up by radiation with the assembly motor + pump or by mechanical friction of the poppet assembly in the valve.	Selection of a motor + pump assembly having a maximum exterior temperature of T4
Static electricity	Electrostatic discharge caused by floating mass	Metal CCV and fittings, electric continuity, Putting to the ground of the unit Low dimension of the valves in POM C

### 1.3. Precautions for Use

This document contains information that all operators should be aware of and understand before using the **UPside CCV** block. This information highlights situations that could result in serious damage and indicates the precautions that should be taken to avoid them.

This equipment was designed in accordance with the "ATEX" 94/9/CE directive.



**WARNING : Before any use of the equipment, check that all operators:**

- have previously be trained by the company Sames Technologies, or by their distributors registered by them for this purpose.
- have read and understood the user manual and all rules for installation and operation, as laid out below.

**It is the responsibility of the operators' workshop manager to ensure these two points and it is also his responsibility to make sure that all operators have read and understood the user manuals for any peripheral electrical equipment present in the spraying area.**

### 1.4. Warnings



**WARNING :** Safety may be jeopardized if this equipment is not operated, disassembled and reassembled in compliance with the instructions given in this manual and in any European Standard or national safety regulations in force.



**WARNING :** Equipment performance is only guaranteed if original spare parts distributed by SAMES Technologies are used.



**WARNING :** Before any operation on a component, it is imperative to rinse the circuit and evacuate any residual pressure (air and product).

## 2. Description

The "UPside CCV" block is a compact, modular color-changing block which is designed to be installed in the robot arm as close as possible to the atomizer. It allows to minimize product losses and optimize the color-changing time. It is designed to hold N modules fitted on two rails different length according to the desired number of colors. A flat seal is used to seal the product passage.

Each module is fitted with a valve "Upvalve" for rapidly selecting (paint or air/solvent). Modules can be added or removed from the block as required.

### 2.1. Presentation of the different modules

- **UPside CCV with return** ([see § 8.1 page 25](#)): standard use, 1 module per color, 1 valve per module. Valve closed, product in the circuit upstream of the valve is in permanent circulation thus avoiding the problems of sedimentation.  
**Remarks:** The paint supply (the biggest hose) is usually performed by the picking with the Sames logo, the recirculation by the opposite conduit.
- **UPside CCV without return** ([see § 8.2 page 26](#)): standard use, 1 module per color, 1 valve per module. Valve closed, product in the circuit upstream of the valve is static
- **UPside CCV, rear closed** ([see § 8.3 page 27](#)): used at each rear end of the n modules. Allows the rinsing of the circuit and the mechanical tightening of all the modules.
- **UPside CCV, front closed** ([see § 8.4 page 29](#)): used at each front end of the n modules for the "turn" circuits fitted necessarily with the single output support module used with "Turn" assembly. Allows the rinsing of the circuit.
- **Selection module** ([see § 8.5.5 page 34](#)): used to select ways for dual circuits (PLC function). Reduce product consumption as well as the useful length.
- **Regulator block** ([see § 8.5.1 page 30](#) and [see § 8.5.2 page 31](#)): used for a paint installation with pump with supervision of motor torque. Also allows to optimize the spraying flows.
- **Shunt pump block** ([see § 8.5.3 page 33](#)): used to replace the pump circuit under the pump (installation without pump).
- **Rear connection / Dump block** ([see § 8.5.4 page 33](#)): used to supply a deported UPside regulator or a UPside color change module (supply/dump by the rear).
- **Single output support module** ([see § 8.5.7 page 35](#)): used on every CCV modules except the UPside CCV front closed. Allows the output of the "in Turn" circuit.
- **Shunt regulator block** ([see § 8.5.6 page 34](#)): used with a pump. Allows to go out directly on the pump by avoiding the regulator.
- **Junction union** ([see § 8.5.9 page 36](#)): allows to put in series two UPside CCV modules (with or without return) in order to create two different circuits supplied by one color only. This configuration allows to work at masked time with dual circuit atomizers.

Configurations hereafter are indicative, the units are modular, the number of colors is adjustable.

**Remark:** The flow direction of the product is done from the back (circulating) toward the front (sprayer).

### 2.1.1. Upside CCV single circuit with regulator

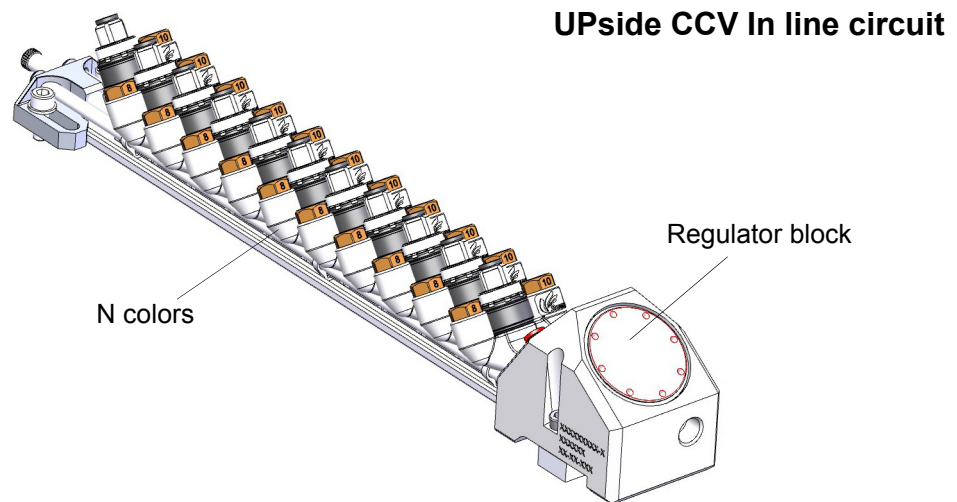

**Remarks:** Standard assembly, the "In line" circuit is used for installations going up to twelve colours. It is possible to go up to 24 colours subject to compatibility with the cycle times of the installation. The presented assembly includes 10 colors + 1 dump block.



**WARNING :** For all the types of assembly, the number of maximum colors is indicated for an indicative time of change of colors of 12s.

Dimensions in mm	L 443 x l 60 x H 81,5
------------------	-----------------------

The step of a module is 25 mm, to add or to subtract according to the number of colors of the installation.

**Example:**

Standard Rinsing

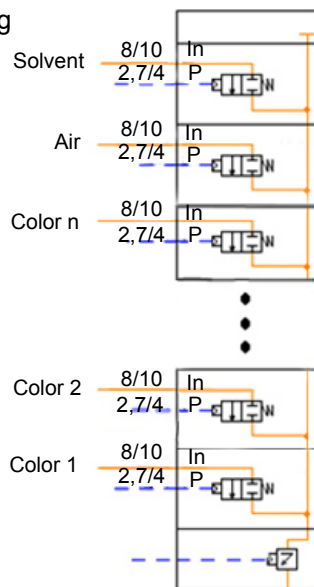

Reverse Rinsing

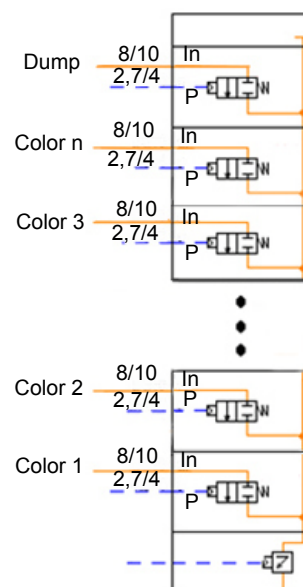



2.1.2. UPSide CCV, type circuit Switch A/B

**UPside CCV circuit Switch A/B**

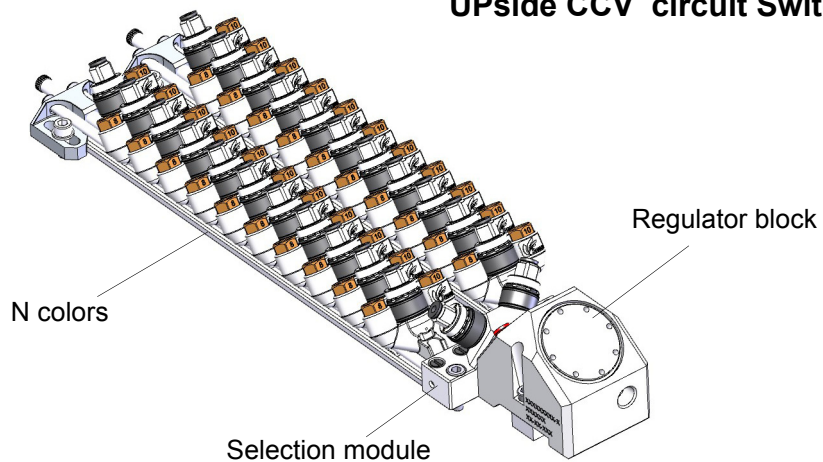

It makes it possible to increase the number of colors while reducing the time of rinsing and the consumption of product. The selection of ways A or B is done by the PLC. It is recommended for installations with 2 X 12 colors maximum.

The presented assembly includes 2x10 colors + 2 dump modules in selection A/B.

Dimensions in mm	L 473 x l 113 x H 81.5
------------------	------------------------

**Example:**

**Reverse Rinsing**

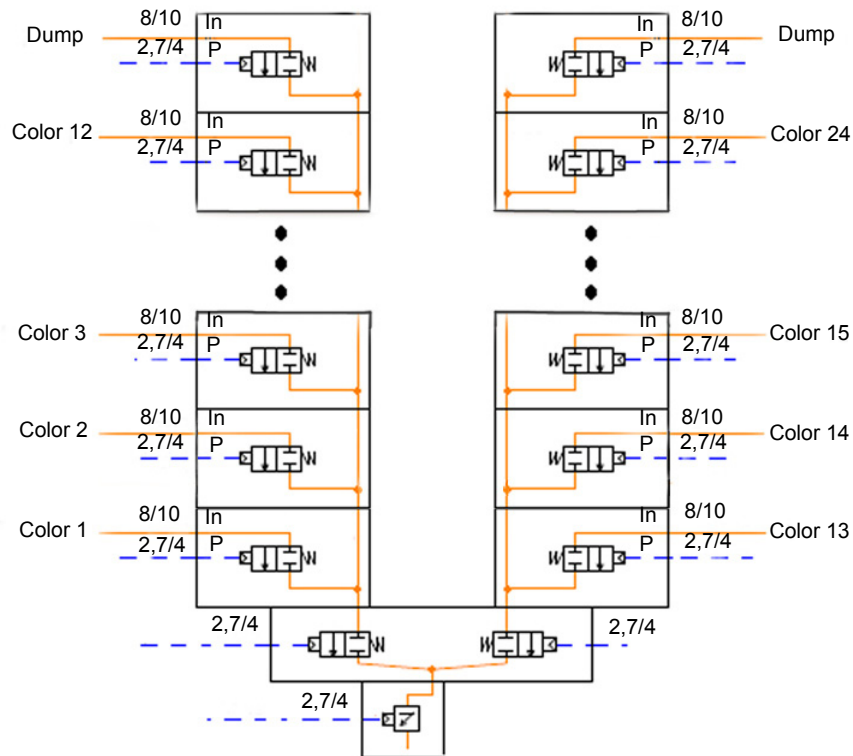

2.1.3. UPside CCV circuit in "Turn"

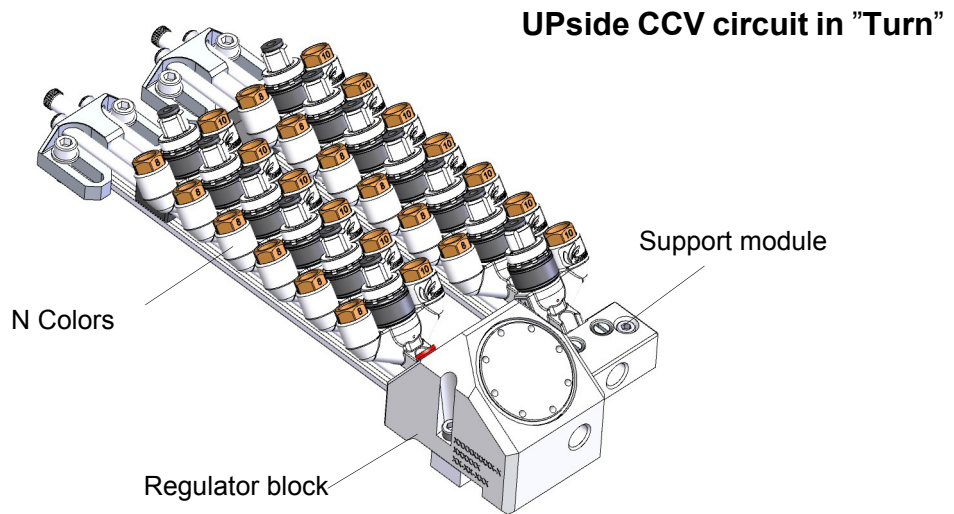

The performances are identical to the "In line" assembly having the same number of colors, it allows to optimize the dimensions in the arm of the robot.  
 The presented assembly includes 12 colors + 1 dump block.  
 The number of colors on each row is not necessarily equal and can be adapted according to the installation.

Dimensions in mm	L 427 x l 118 x H 81.5
------------------	------------------------

**Example:**

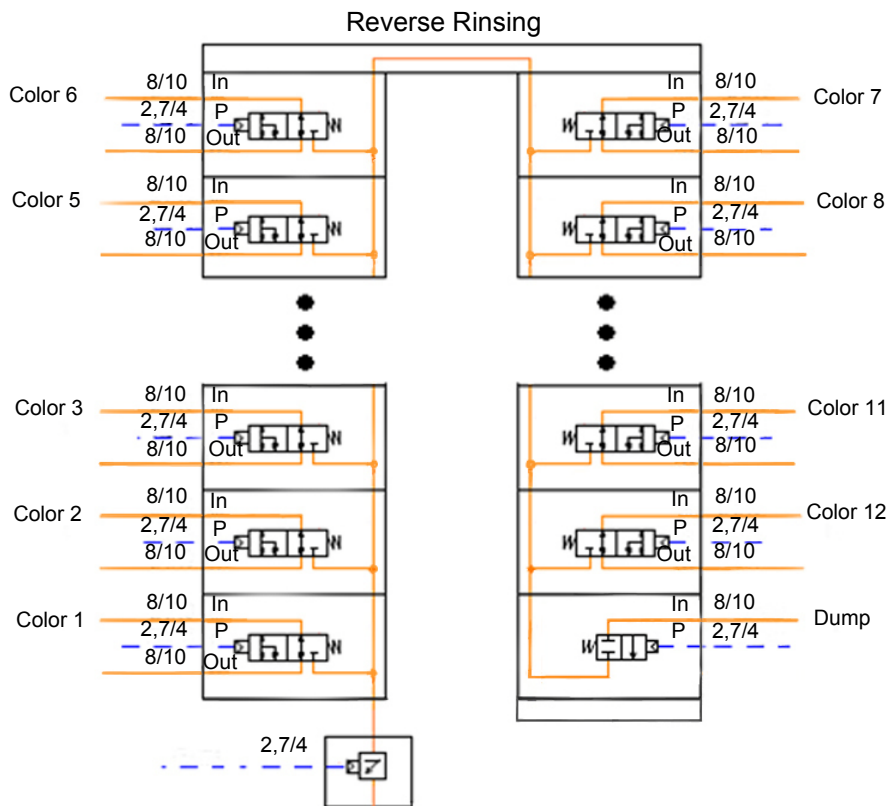

2.1.4. UPSide CCV dual circuit

**UPSide CCV dual circuit**

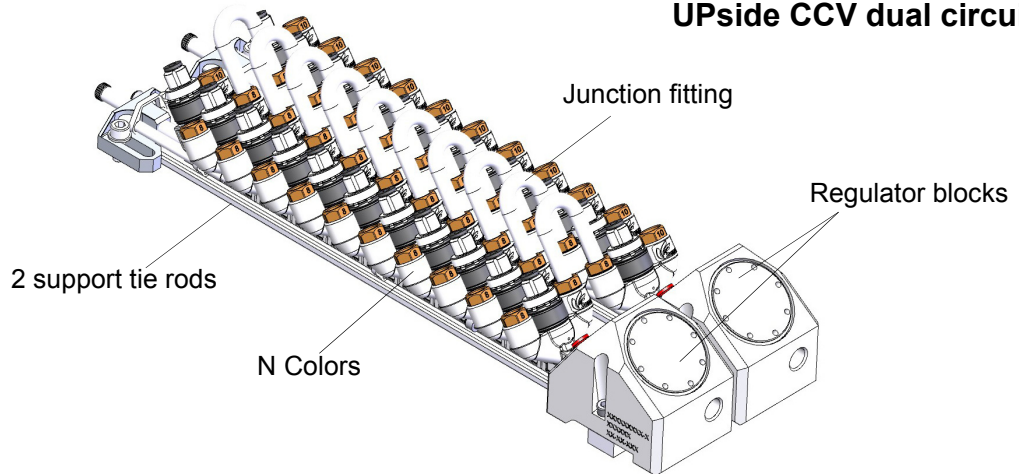

Used with the dual circuit atomizers, it makes it possible to work in masked time. Only one paint supply is necessary for 2 independent paint antennas. It is recommended for installations with 12 colors maximum.

The presented assembly includes 10 colors + 1 dump module by row.

Dimensions in mm	L 443 x l 123 x H 81.5
------------------	------------------------

**Example:**

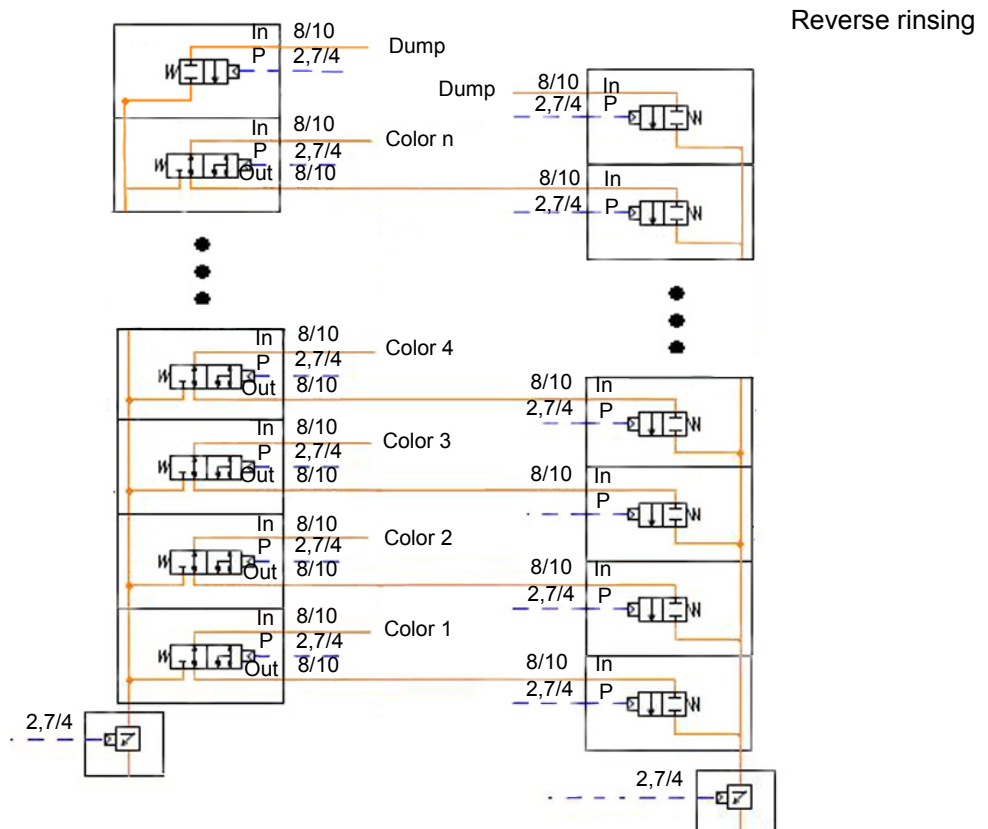

## 2.2. Characteristics

Paint		
	Flow rate	50 to 2000 cc/min max (depended on paint)
	Maximum pressure	20 bar
	Viscosity solvented paints (SB)	20 to 50 seconds - FORD cup # 4
		20 to 45 seconds - AFNOR cup # 4
	Viscosity waterborne paints (WB)	200 mPa.s à 250s <sup>-1</sup>
Air pressure		
	Valve pilot	5 bar (min.) - 8 bar (max.)
Compressed air quality		
	Filtered air must be dry, and free of oil and dust as per <b>DIN ISO 8573-1</b>	
	Maximum dewpoint at 5.5 bar (80 psi)	Class 2 i.e - 40° C (-40° F)
	Maximum particle of solid contaminants (Others)	Class 3 i.e Ø 5 µm
	Maximum concentration of oil	Class 1 i.e 0.01 mg / m <sub>0</sub> <sup>3*</sup>
	Maximum concentration of solid contaminants	1 mg /m <sub>0</sub> <sup>3**</sup>
Weight		
	UPside CCV with return equipped with 2- 8/10 fittings and UPvalve	101 g
	UPside CCV without return equipped with 1- 8/10 fitting and UPvalve	78 g
Dimensions		
	UPside CCV with return equipped with 2- 8/10 fittings	Step 25 mm, width 55.5 mm, height 48 mm
	UPside CCV without return equipped with 1- 8/10 fitting	Step 25 mm, width 40 mm, height 48 mm

**Nota:**

\*\* m<sub>0</sub><sup>3</sup> values given for a temperature of 20°C (68°F) and atmospheric pressure (1013 bar).

Response time of the UPvalves:

Length of UPvalve piloting in meter	Opening Response time in ms (complete opening)	Closing Response time in ms (complete closing)
3	60	85
8	160	200
12	270	370
20	480	600

### 3. Operating

Every UPside module supports an UPvalve which is used for the supply either in air, either in solvent or in color of fluid circuit. It allows possibly to direct the product towards a dump circuit.

The selection of a fluid in an "UPside CCV" block is done via the "UPvalve", for the whole of the block, only one color valve must be in Open position at the same time.

A solenoid valve is used to control opening and closing of each valve via the pilot hose located on the top of the valve.

At each change of color, a cleaning cycle must be carried out by successively piloting the air and solvent valves.



**WARNING : The simultaneous opening of the air and solvent valves must be prohibited in the software so that there is no return of product towards the other one. A check valve must be placed, by safety, on the air supply upstream of the UPvalve.**

When not in use, the UPvalves are closed. Product arriving upstream cannot flow through, but continues to flow towards the return of the circulating (for a module with return).

When the UPvalve control air is pressurized, the piston compresses the spring which the axis and the needle backwards, thus the product can flow towards the exit through the seat of the block.

Hole located on the side of the module is provided for detecting leaks.

#### 4. Tools

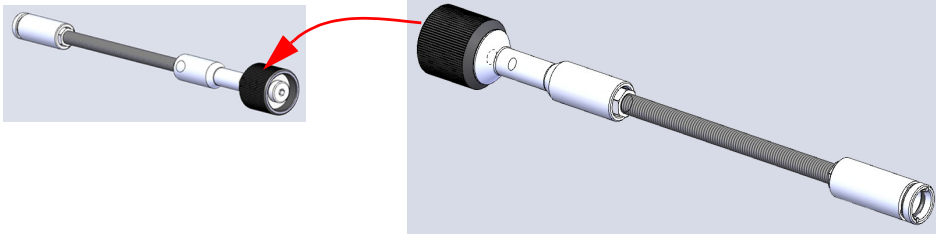

Part Number	Description	Qty	Unit of sale
910013686	Torque wrench for installation / removal valve	1	1

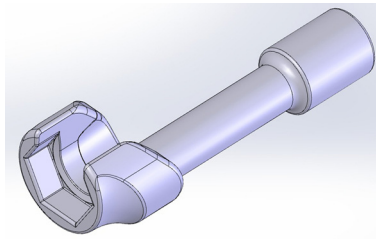

Part Number	Description	Qty	Unit of sale
910018362	Installation / removal tool of fittings	1	1
910021362	Installation / removal tool of fitting P/N # 910019671	1	1

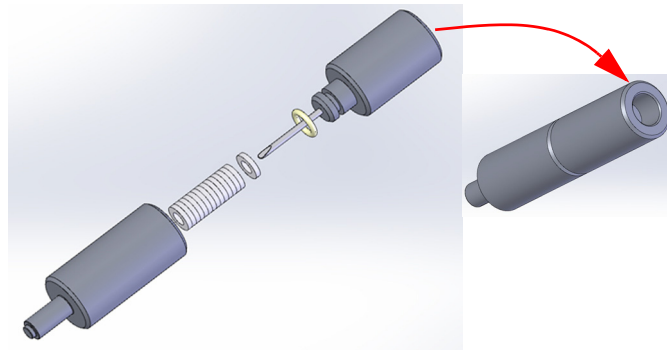

Part Number	Description	Qty	Unit of sale
910015840	Installation / Withdrawal tool for flat seal and gauge for hose replacement	1	1

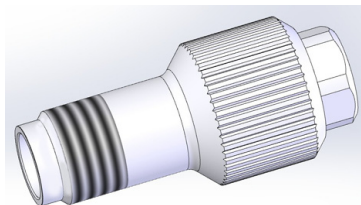

Part Number	Description	Qty	Unit of sale
900010965	Installation tool for nipples of UPSide fittings	1	1



Item	Part Number	Description	Qty	Unit of sale
1	240000292	Set of nipple extractors	1	1
2	240000293	Ratchet support tool	1	1
	240000294		1	1



Part Number	Description	Qty	Unit of sale
741015	Wrench, regulator nut removal	1	1

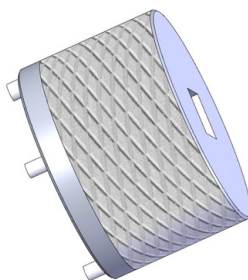

Part Number	Description	Qty	Unit of sale
1403479	Tool, automatic torque control, regulator nut	1	1

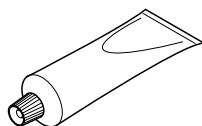

DES00685

Part Number	Description	Qty	Unit of sale
H1GMIN017	White vaseline (100 ml)	1	1



Part Number	Description	Qty	Unit of sale
F6RXZZ129	PTFE grease	1	1

**Additional tools and accessories required:**

The tools listed below should be available for product installation and maintenance operations.

- Hose cutter (P/N W3SCTU002).
- Allen wrench (4 and 5 mm).
- Flat wrenches (13 and 19 mm).
- Universal tongs.
- Torque wrench.
- Screwdriver (small).



## 5. Installation

### 5.1. Installation of UPside fitting and hose on UPside CCV module

- Place the nipple equipped with its o-ring on the tool (P/N # 900010965) or directly in the bottom of the body. Grease the tool, bearing surface and threading using paste PTFE (P/N # F6RXZZ129) before crimping the nipple.



- Screw the nipple into the module with a tightening torque of 18 N.m.



- Put the hose until it stops on the first shoulder into the tool (P/N # 910015840) and do a reference mark. Place the nut of the fitting on the hose.



Coat with white assembly paste PTFE (P/N # F6RXZZ129) the hose on a 1 cm length.  
**It is imperative not to cover the mark.**



- Push the hose in the block up to the mark.

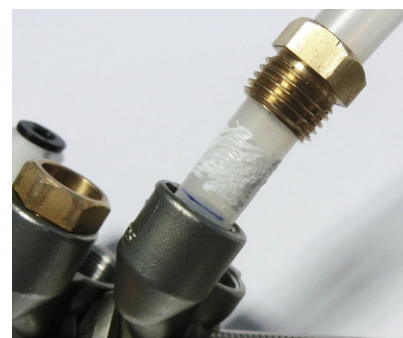

- Screw the nut of the fitting with tool (P/N 910018362) with a torque of 11 N.m.



## 5.2. Recommendations of installation on air dump assembly

Calculation length hose 4/6 air dump assembly
Simplified calculation: mini length of pipe 4/6 PTFE in cm = 1/2 total number of modules of the antenna
Example for 12 modules: $12 \times 0.5 = 6$ cm minimum
Typical case: circuit «In Turn»: add 4 modules in calculation for the back junction

## 6. Maintenance



**WARNING** : Always refer to the health and safety instructions before carrying out any work ([see § 1.3 page 6](#)).

### 6.1. Summary table of maintenance operations

Procedure	Description	Preventive	Corrective	Duration	Frequency
<b>A</b>	Exterior cleaning of UPside CCV block	X		3 mn	<a href="#">see § 6.2.1 page 19</a>
<b>B</b>	Replacement of UPside CCV module		X	10 mn	X
<b>C</b>	Replacement of flat seal		X	10 mn	
<b>D</b>	Replacement of valve		X	5 mn	
<b>E</b>	Replacement of fittings and hoses		X	15 mn*	
<b>F</b>	Replacement of regulator		X	10 mn	

\* Depending on robot dressing.

### 6.2. Preventive Maintenance

#### 6.2.1. Procedure A: Cleaning of exterior

In every change of protection of the robot arm, verify the cleanliness of the block UPside CCV.

If necessary, using a cloth moistened with an appropriate solvent, clean the block and dry with compressed air.

### 6.3. Corrective Maintenance

#### 6.3.1. Procedure B: Replacement of UPside CCV module

- Remove hoses of the defective block. Using a 5 mm Allen wrench, unscrew the screw of the rear fixing kit. Put back enough the screw to be able to separate the modules.



- Separate the module and remove it from the tie rods.

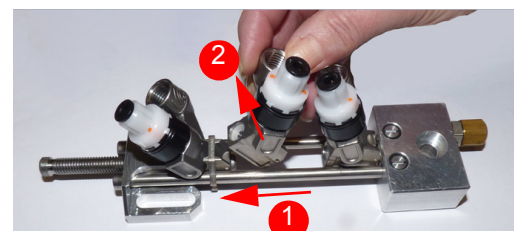

- For reassembling, proceed in reverse order**  
Tighten the screw of the rear fixing kit with a torque of 9 N.m by having beforehand putting PTFE paste (P/N # F6RXZZ129) on the threading .

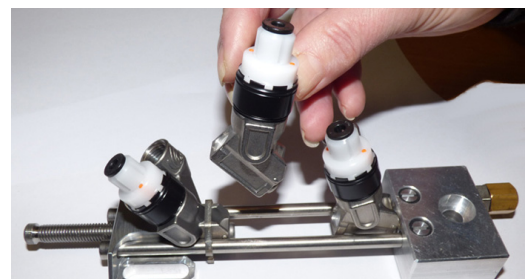

### 6.3.2. Procedure C: Replacement of flat seal

- Separate the extraction part from the assembling part of the tool (P/N: 910015840).

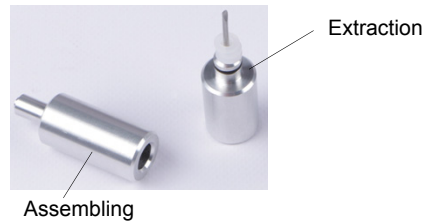

- Extract the seal with the tool side extraction.



**WARNING :** Every time the seal is removed, replace it systematically.



### Replacement of the seal:

- Maintain the new flat seal on the tool then push it until it stops in the block.



### 6.3.3. Procedure D: Replacement of the UPvalve

- Position the tool (P/N 910013686) on the UPvalve, loosen the UPvalve and remove it.



**If the valve is locked**, insert a 4mm Allen wrench on the back of the tool, place the assembly on the valve and loosen.



#### Installation of the UPvalve on a UPSide CCV:



**WARNING** : It is recommended to coat the threading of the valve with vaseline (P/N # H1GMIN017) before re-installation.

- Place the UPvalve on the tool. Check that the o-ring is in place on the bottom of the valve.
- Place the valve in the module and tighten it with the black button until it slides.

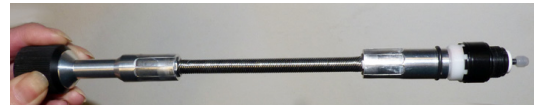

**WARNING** : It is imperative to use the black button for the tightening because the tightening torque is integrated.



**WARNING** : To operate the torque wrench without Upvalve after a period of non-utilization (slip button operates on the body) in order to avoid a on-couple due to a gumming of the key.





#### 6.3.4. Procedure E: Replacement of hoses

- Unscrew the nut of the fitting using tool (P/N 910018362) and remove the hose from the block. Replace the hose.



- Unscrew the nipple using the appropriate extractor.



- Remove the nipple from the module.



- Using an universal tongs, unscrew the nipple from extractor. After removal, replace systematically the nipple and its o-ring.



**Reassembly:** [see § 5.1 page 17.](#)

### 6.3.5. Procedure F: Maintenance of regulator

- Loosen regulator nut using tool (P/N 741015) and remove it.



- With a small pair of pliers, pull delicately the diaphragm kit out.

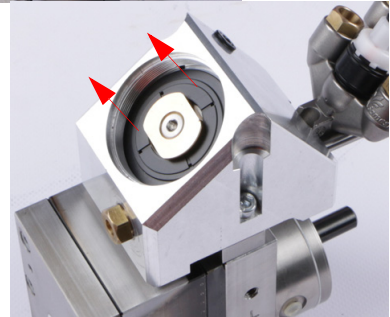

- Loosen the seat using a 4 mm Allen wrench and remove it.



- Take the ball and the spring out gently with a small pair of pliers.



**WARNING :** Replace the o-ring every time the seat is disassembled.



**WARNING :** Every time the regulator is disassembled, clean all the components using a cloth moistened with solvent then dry carefully with compressed air.



**WARNING :** Check the wear of diaphragm, replace if necessary.

**For reassembling: proceed in reverse order:**

- Tighten the regulator seat with a torque of 8 N.m.
- Tighten the regulator nut with a torque of 18 N.m.



### 6.3.5.1. Maintenance of diaphragm kit

- Keep the nut of the kit in place using a 19 mm flat wrench.
- Loosen the diaphragm pusher using a 4 mm allen wrench.



- Remove the diaphragm.

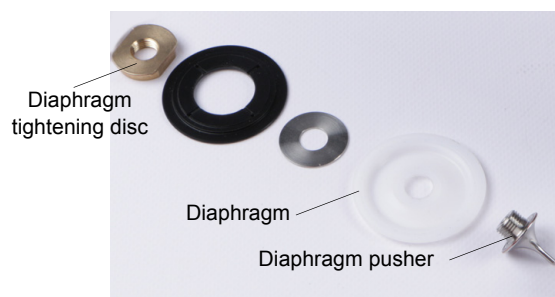

- **For reassembling, proceed in reverse order:**  
 Install the diaphragm on the diaphragm pusher. **The wavy side is on the material side.** Place the spacer.  
 Put in place the diaphragm tightening disc, (its flat side to the diaphragm).  
 Tighten the diaphragm pusher as well as the diaphragm tightening disc with a torque of 10 N.m

## 7. Troubleshooting

Symptoms	Possible causes	Solutions
Modules are not tight among themselves.	The flat seal between the modules is defective	Remove the module et replace the seal
A flow of product in the main channel occurs, valve closed	The valve poppet is defective.	Replace the valve
A module is leaking at the front of the leak detection hole	The valve of the module is no longer tight	Replace the valve
A module is leaking at the visible base of the valve	The valve of the module is no longer tight	Replace the valve
A paint return is done by the barrel of the valve	The valve of the module is no longer tight	Replace the valve



## 8. Spare parts



**WARNING :** The performance of the UPside CCV blocks is guaranteed only with the use of the specific fittings Sames.

### 8.1. UPside CCV with return

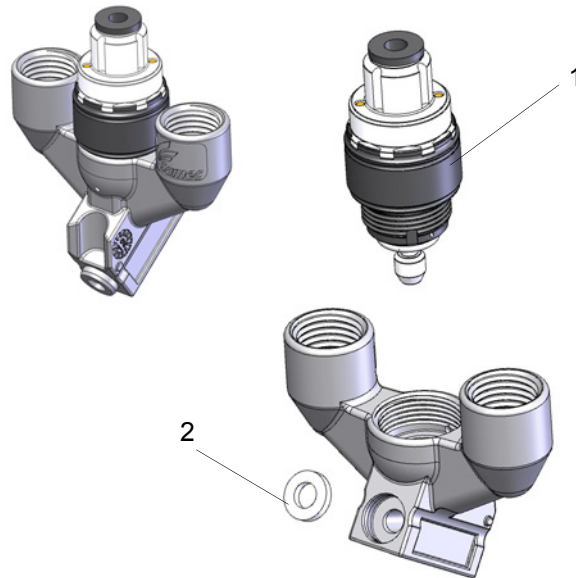

Item	Part Number	Description	Qty	Unit of Sale	Maintenance level for Spare parts (*)
	<b>910012869S</b>	<b>UPside CCV with return</b>	<b>1</b>	<b>1</b>	<b>3</b>
1	910012239S	UPvalve, pilot valve ( <a href="#">see § 8.6.1 page 38</a> )	1	1	1
2	900010461	Flat seal PEHD	1	1	1

Item	Part Number	Description	Qty	Unit of Sale	Maintenance level for Spare parts (*)
	<b>910012869-2KS</b>	<b>UPside CCV 2K with return</b>	<b>1</b>	<b>1</b>	<b>3</b>
1	910016428S	UPvalve 2K, pilot valve ( <a href="#">see § 8.6.2 page 38</a> )	1	1	1
2	900010461	Flat seal PEHD	1	1	1

(\*) Level 1: Standard preventive maintenance

Level 2: Corrective maintenance

Level 3: Exceptional maintenance



**WARNING :** The paint supply (the biggest hose) is always installed on the picking with the logo SAMES, the recirculation by the opposite conduit.

## 8.2. UPside CCV without return

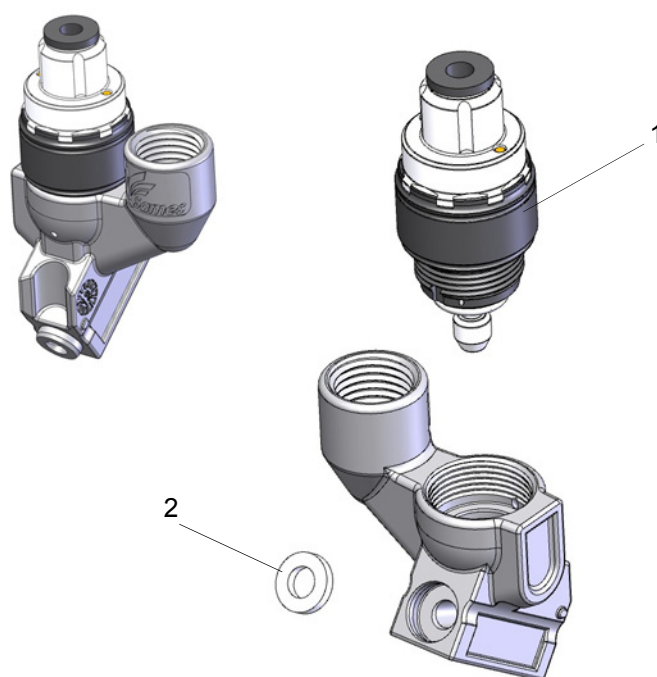

Item	Part Number	Description	Qty	Unit of Sale	Maintenance level for Spare parts (*)
	<b>910012870S</b>	<b>UPside CCV without return</b>	<b>1</b>	<b>1</b>	<b>3</b>
1	910012239S	UPvalve, pilot valve ( <a href="#">see § 8.6.1 page 38</a> )	1	1	1
2	900010461	Flat seal PEHD	1	1	1

Item	Part Number	Description	Qty	Unit of Sale	Maintenance level for Spare parts (*)
	<b>910012870-2KS</b>	<b>Upside CCV 2K without return</b>	<b>1</b>	<b>1</b>	<b>3</b>
1	910016428S	UPvalve 2K, pilot valve ( <a href="#">see § 8.6.2 page 38</a> )	1	1	1
2	900010461	Flat seal PEHD	1	1	1

(\*)

Level 1: Standard preventive maintenance

Level 2: Corrective maintenance

Level 3: Exceptional maintenance

### 8.3. UPside CCV, rear closed

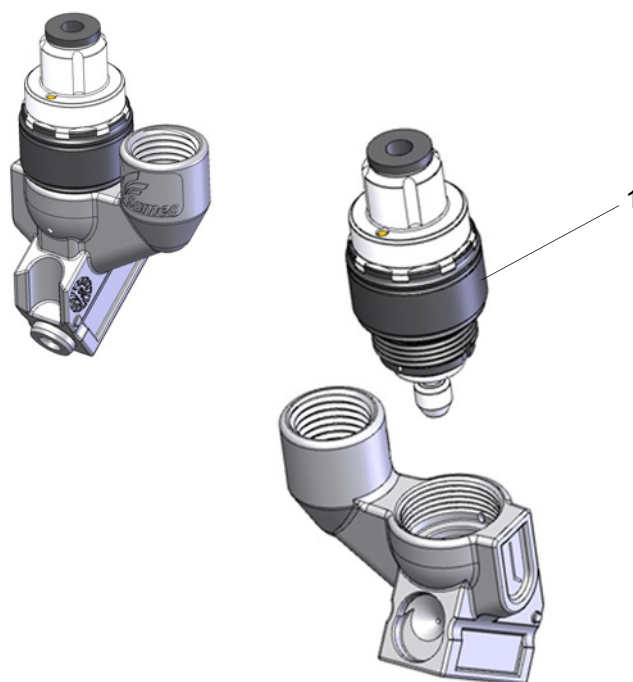

Item	Part Number	Description	Qty	Unit of Sale	Maintenance level for Spare parts (*)
	<b>910013768S</b>	<b>UPside CCV rear closed</b>	<b>1</b>	<b>1</b>	<b>3</b>
<b>1</b>	<b>910012239S</b>	<b>UPvalve, pilot valve</b> (see § 8.6.1 page 38)	<b>1</b>	<b>1</b>	<b>1</b>

Item	Part Number	Description	Qty	Unit of Sale	Maintenance level for Spare parts (*)
	<b>910013768-2KS</b>	<b>Upside CCV 2K rear closed</b>	<b>1</b>	<b>1</b>	<b>3</b>
<b>1</b>	<b>910016428S</b>	<b>UPvalve 2K, pilot valve</b> (see § 8.6.2 page 38)	<b>1</b>	<b>1</b>	<b>1</b>

(\*)

**Level 1: Standard preventive maintenance**

**Level 2: Corrective maintenance**

**Level 3: Exceptional maintenance**

### 8.3.1. Rinsing open

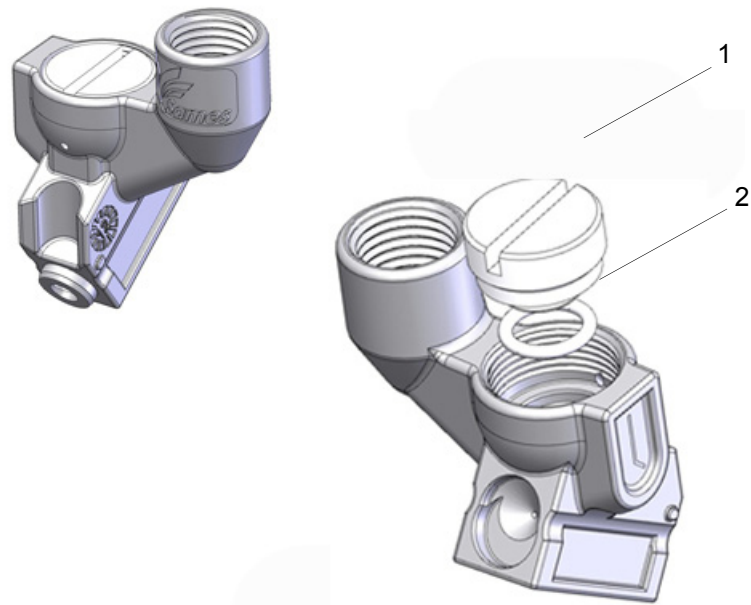

Item	Part Number	Description	Qty	Unit of Sale	Maintenance level for Spare parts (*)
	<b>910013768-ROS</b>	<b>UPside CCV rear closed, rinsing open</b>	<b>1</b>	<b>1</b>	<b>3</b>
1	900012901	Plug	1	1	3
2	J3STKL102	O-ring - chemically inert	1	1	1

(\*)

**Level 1: Standard preventive maintenance**

**Level 2: Corrective maintenance**

**Level 3: Exceptional maintenance**

#### 8.4. UPside CCV, front closed

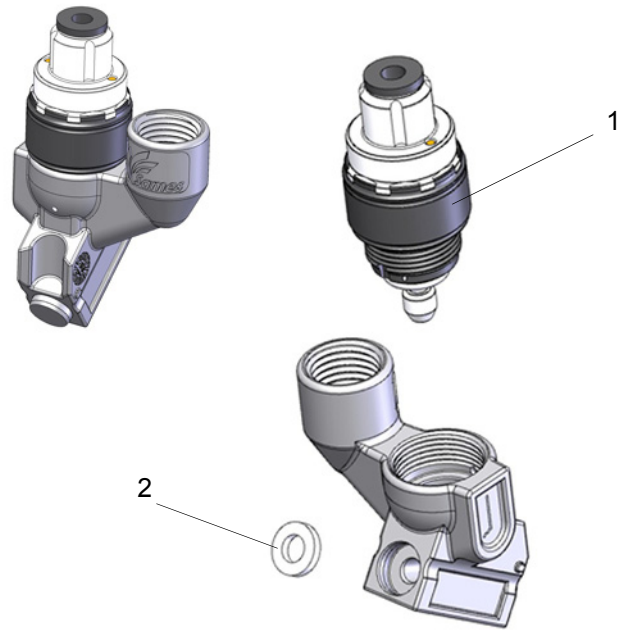

Item	Part Number	Description	Qty	Unit of Sale	Maintenance level for Spare parts (*)
	<b>910015723S</b>	<b>UPside CCV front closed</b>	<b>1</b>	<b>1</b>	<b>3</b>
1	<b>910012239S</b>	<b>UPvalve, pilot valve</b> (see § 8.6.1 page 38)	1	1	1
2	900010461	Flat seal PEHD	1	1	1

(\*)

**Level 1: Standard preventive maintenance**

**Level 2: Corrective maintenance**

**Level 3: Exceptional maintenance**

## 8.5. Accessories

### 8.5.1. Regulator block

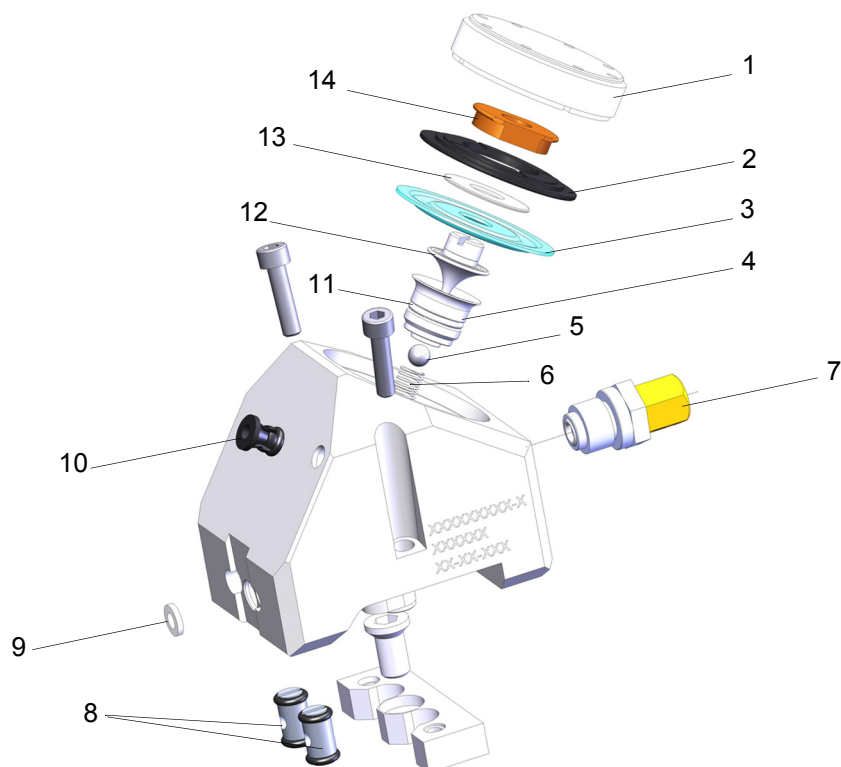

Item	Part Number	Description	Qty	Unit of Sale	Maintenance level for Spare parts (*)
	<b>910016857</b>	<b>Regulator block</b>	<b>1</b>	<b>1</b>	<b>3</b>
1	900009331	Cover, regulator	1	1	3
2	900010428	Washer, diaphragm tightening	1	1	3
3	1408616	Diaphragm, thick 0.8 mm	1	1	1
4	900010505	Regulator seat	1	1	2
5	K6RKBL383	Ball, dia.:6	1	1	2
6	Q2HRDC146	Spring	1	1	2
7	-	<b>Rack Fitting</b> ( <a href="#">see § 8.9 page 42</a> )	<b>1</b>	<b>1</b>	<b>3</b>
8	<b>910015684</b>	<b>Equipped nut</b>	<b>2</b>	<b>1</b>	<b>3</b>
9	900010461	Flat seal PEHD	1	1	1
10	F6RXZG081	Pneumatic cartridge assy + viton seal	1	1	2
11	J3STKL160	O-ring - chemically inert	1	1	1
12	1411420	Diaphragm pusher,	1	1	2
13	1404261	Spacer, air distribution	1	1	2
14	1404887	Disc, diaphragm tightening	1	1	2

(\*) Level 1: Standard preventive maintenance

Level 2: Corrective maintenance

Level 3: Exceptional maintenance

### 8.5.2. Regulator block, 2 sensors

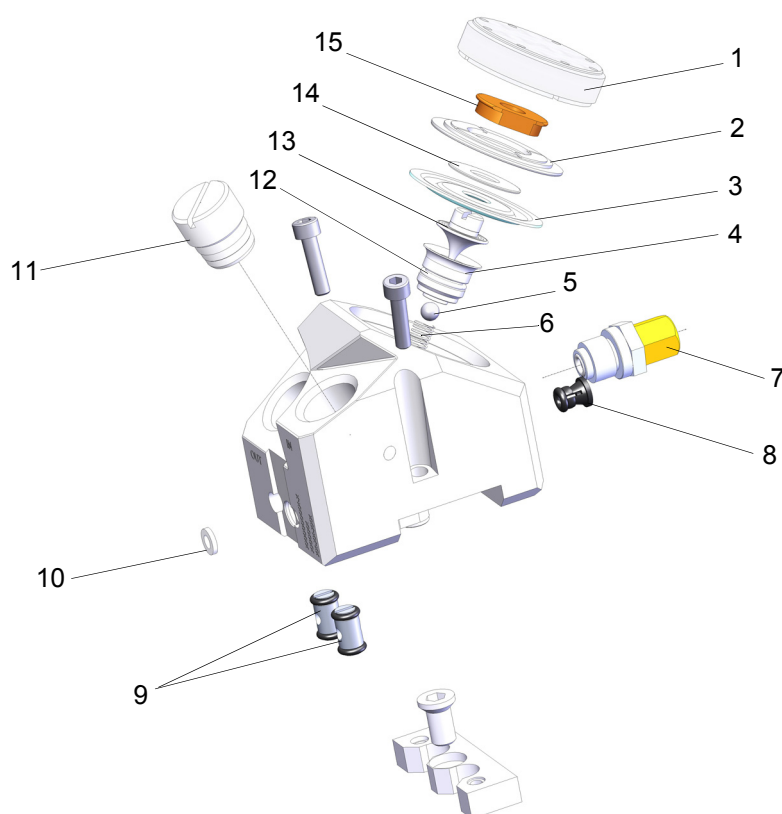

Item	Part Number	Description	Qty	Unit of Sale	Maintenance level for Spare parts (*)
	<b>910021092</b>	<b>Regulator block, 2 sensors</b>	<b>1</b>	<b>1</b>	<b>3</b>
1	900009331	Cover, regulator	1	1	3
2	900010428	Washer, diaphragm tightening	1	1	3
3	1408616	Diaphragm, thick 0.8 mm	1	1	1
4	900010505	Regulator seat	1	1	2
5	K6RKBL383	Ball, dia.:6	1	1	2
6	Q2HRDC146	Spring	1	1	2
7	-	<b>Rack Fitting</b> ( <a href="#">see § 8.9 page 42</a> )	<b>1</b>	<b>1</b>	<b>3</b>
8	F6RXZG081	Pneumatic cartridge assy + viton seal	1	1	2
9	<b>910015684</b>	<b>Equipped nut</b>	<b>2</b>	<b>1</b>	<b>3</b>
10	900010461	Flat seal PEHD	1	1	1
11	900014134	Plug	1	1	3
12	J3STKL160	O-ring - chemically inert	1	1	1
13	1411420	Diaphragm pusher,	1	1	2
14	1404261	Spacer, air distribution	1	1	2
15	1404887	Disc, diaphragm tightening	1	1	2

(\*) **Level 1: Standard preventive maintenance**

**Level 2: Corrective maintenance**

**Level 3: Exceptional maintenance**

8.5.2.1. Pressure sensors' use



**WARNING :** The integration of the pressure sensor must be realized according to the standards EN60079-14 and EN60079-25.

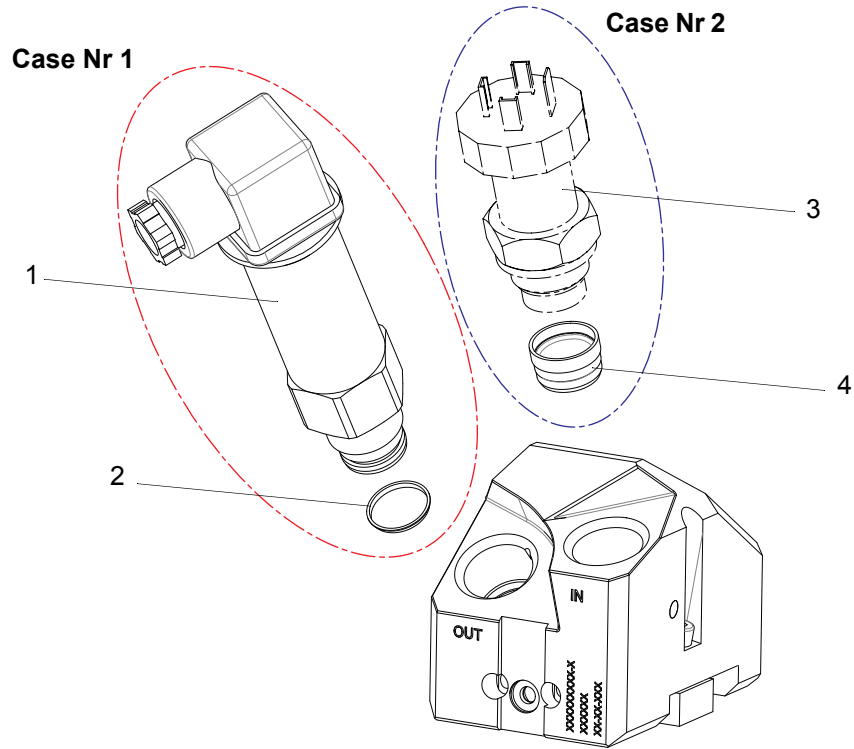

Item	Part Number	Description	Qty	Unit of Sale	Maintenance level for Spare parts (*)
<b>Case Nr 1</b>					
1	220000068AT	Pressure sensor 0-50 bar	-	1	3
2	900010877	Low seal of sensor	1	1	3
<b>Case Nr 2</b>					
3	-	Pressure sensor	-	1	3
4	900013967	Low seal of sensor	-	1	3

(\*)

**Level 1: Standard preventive maintenance**

**Level 2: Corrective maintenance**

**Level 3: Exceptional maintenance**



### 8.5.3. Shunt pump block

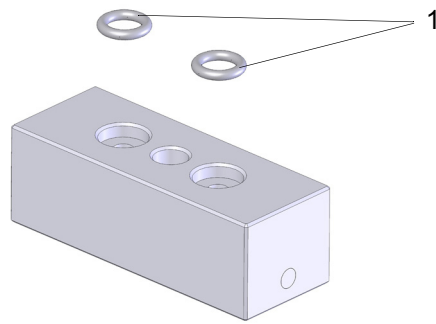

Item	Part Number	Description	Qty	Unit of Sale	Maintenance level for Spare parts (*)
	<b>910016296</b>	<b>Shunt pump block</b>	<b>1</b>	<b>1</b>	<b>3</b>
1	J3STKL011	O-ring - chemically inert	2	1	1

(\*)

**Level 1: Standard preventive maintenance**

**Level 2: Corrective maintenance**

**Level 3: Exceptional maintenance**

### 8.5.4. Rear connection / Dump block

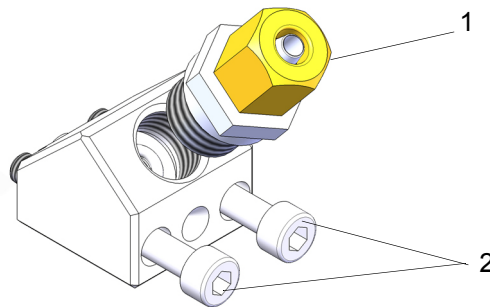

Item	Part Number	Description	Qty	Unit of Sale	Maintenance level for Spare parts (*)
	<b>910016871</b>	<b>Rear connection / Dump block</b>	<b>1</b>	<b>1</b>	<b>3</b>
1	-	<b>Rack fitting</b> ( <a href="#">see § 8.9 page 42</a> )	<b>1</b>	<b>1</b>	<b>3</b>
2	X3AVSY190	Zinc coated Chc M 5 / 40 screw	2	1	3

(\*)

**Level 1: Standard preventive maintenance**

**Level 2: Corrective maintenance**

**Level 3: Exceptional maintenance**

### 8.5.5. Selection block

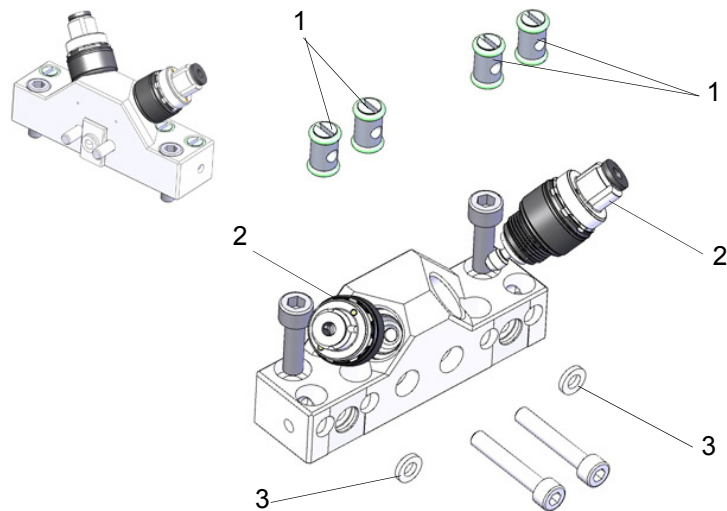

Item	Part Number	Description	Qty	Unit of Sale	Maintenance level for Spare parts (*)
	<b>910012871</b>	<b>Selection block</b>	<b>1</b>	<b>1</b>	<b>3</b>
<b>1</b>	<b>910015684</b>	<b>Equipped nut</b>	<b>4</b>	<b>1</b>	<b>3</b>
<b>2</b>	<b>910012239S</b>	<b>Upvalve (see § 8.6.1 page 38)</b>	<b>1</b>	<b>1</b>	<b>1</b>
<b>3</b>	900010461	Flat seal PEHD	2	1	1

(\*) Level 1: Standard preventive maintenance

Level 2: Corrective maintenance

Level 3: Exceptional maintenance

### 8.5.6. Shunt regulator block

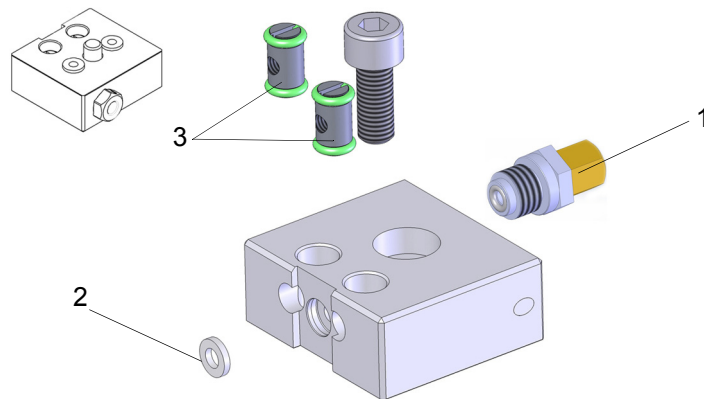

Item	Part Number	Description	Qty	Unit of Sale	Maintenance level for Spare parts (*)
	<b>910016269</b>	<b>Shunt regulator block</b>	<b>1</b>	<b>1</b>	<b>3</b>
<b>1</b>	-	<b>Rack Fitting (see § 8.9 page 42)</b>	<b>1</b>	<b>1</b>	<b>3</b>
<b>2</b>	900010461	Flat seal PEHD	1	1	1
<b>3</b>	<b>910015684</b>	<b>Equipped nut</b>	<b>2</b>	<b>1</b>	<b>3</b>

### 8.5.7. Single output support block

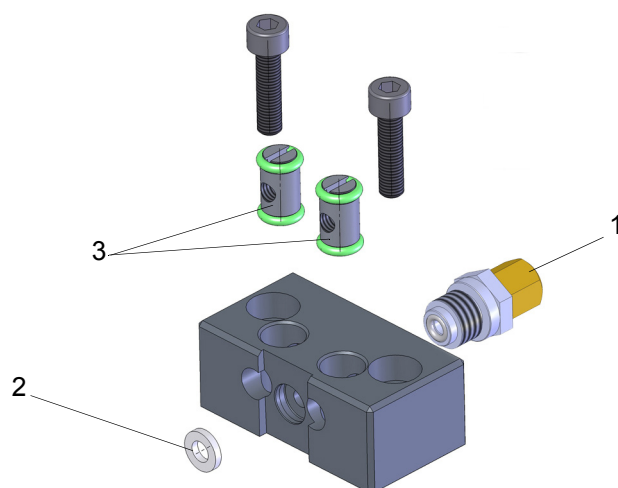

Item	Part Number	Description	Qty	Unit of Sale	Maintenance level for Spare parts (*)
	<b>910015687</b>	<b>Single output support block</b>	<b>1</b>	<b>1</b>	<b>3</b>
<b>1</b>	-	<b>Rack Fitting</b> ( <a href="#">see § 8.9 page 42</a> )	<b>1</b>	<b>1</b>	<b>3</b>
<b>2</b>	900010461	Flat seal PEHD	<b>1</b>	<b>1</b>	<b>1</b>
<b>3</b>	<b>910015684</b>	<b>Equipped nut</b>	<b>2</b>	<b>1</b>	<b>3</b>

(\*)

**Level 1: Standard preventive maintenance**

**Level 2: Corrective maintenance**

**Level 3: Exceptional maintenance**

### 8.5.8. Rear junction block

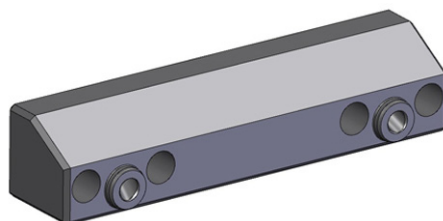

Item	Part Number	Description	Qty	Unit of Sale	Maintenance level for Spare parts (*)
	900010386	Rear junction block used with "Turn" assembly	1	1	3

(\*)

**Level 1: Standard preventive maintenance**

**Level 2: Corrective maintenance**

**Level 3: Exceptional maintenance**

### 8.5.9. Junction union

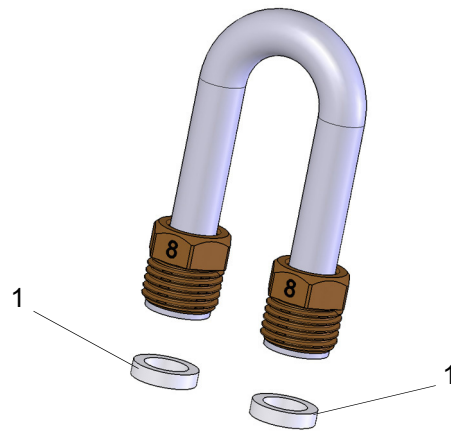

Item	Part Number	Description	Qty	Unit of Sale	Maintenance level for Spare parts (*)
	<b>910017724</b>	<b>Junction union</b>	<b>1</b>	<b>1</b>	<b>3</b>
1	900010934	Seal	2	1	3

(\*)

**Level 1: Standard preventive maintenance**

**Level 2: Corrective maintenance**

**Level 3: Exceptional maintenance**

### 8.5.10. Spring for Air dump assembly for circuit in line

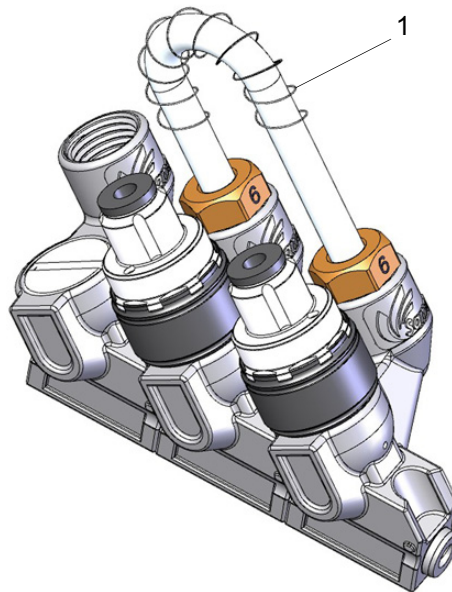

Item	Part Number	Description	Qty	Unit of Sale	Maintenance level for Spare parts (*)
1	200000275	Spring, stroke: 7 C.:0.55 Length: 3	1	1	3

### 8.5.11. Upside CCV support

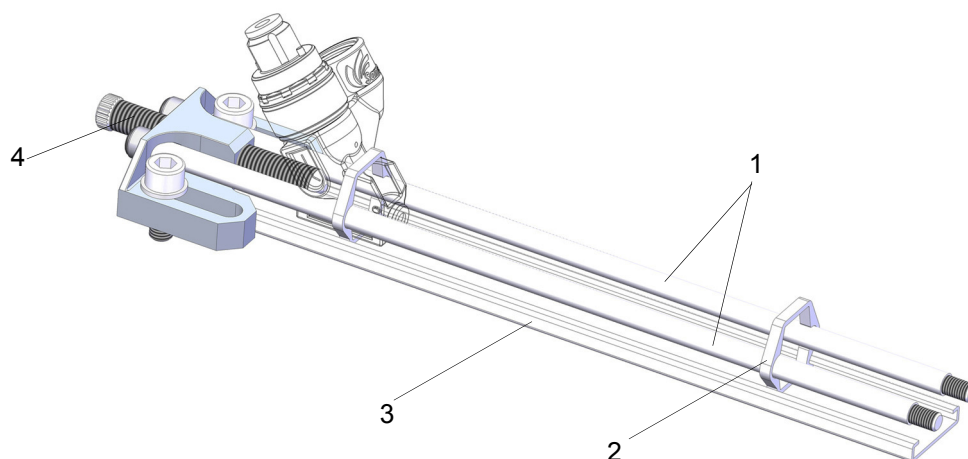

Item	Part Number	Description	Qty	Unit of Sale	Maintenance level for Spare parts (*)
	<b>910017888-XX</b>	<b>UPside CCV support **</b>	<b>1</b>	<b>1</b>	<b>3</b>
1	900011183-XX	UPside CCV support tie rods **	2	1	3
2	900011594	Support guide spacer ***	X	1	3
3	900013948-XX	Support rail **	1	1	3
4	<b>910015680</b>	<b>Rear fixing kit</b>	<b>1</b>	<b>1</b>	<b>3</b>

(\*) Level 1: Standard preventive maintenance

Level 2: Corrective maintenance

Level 3: Exceptional maintenance



**WARNING :** \*\* -XX corresponds to the total number of modules UPside CCV including possibly the rear junction block.



**WARNING :** \*\*\* A spacer must be installed every 5 modules knowing that the first one is placed after the first block.

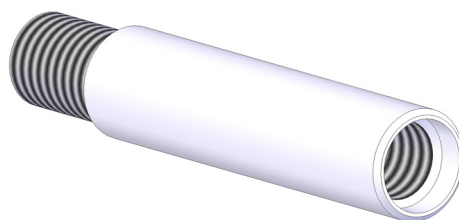

Item	Part Number	Description	Qty	Unit of Sale	Maintenance level for Spare parts (*)
	900011183-R1	Tie rod extension for 1 module	1	1	3

(Makes it possible to add 1 module on an existing support).

## 8.6. UPvalves

### 8.6.1. Standard Upvalve

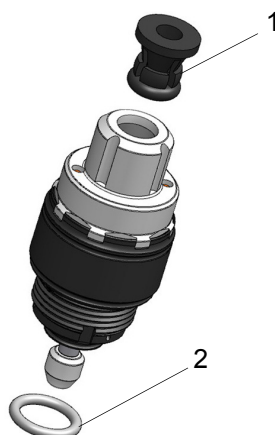

Item	Part Number	Description	Qty	Unit of Sale	Maintenance level for Spare parts (*)
	<b>910012239S</b>	<b>UPvalve, pilot valve</b>	<b>1</b>	<b>1</b>	<b>1</b>
1	F6RXZG081	Black grip + o-ring	1	1	3
2	J3STKL102	O-ring - chemically inert	1	1	1

### 8.6.2. 2K Upvalve with bellow

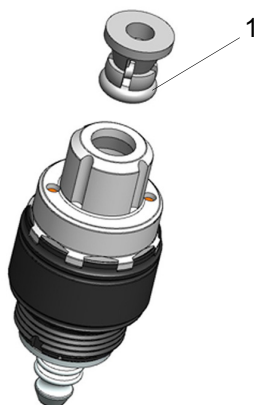

Item	Part Number	Description	Qty	Unit of Sale	Maintenance level for Spare parts (*)
	<b>910016428S</b>	<b>UPvalve 2K, pilot valve with bellow</b>	<b>1</b>	<b>1</b>	<b>1</b>
1	130001337	Stainless steel grey grip + o-ring	1	1	3

(\*)

**Level 1: Standard preventive maintenance**

**Level 2: Corrective maintenance**

**Level 3: Exceptional maintenance**



**WARNING : WARNING :** It is recommended to coat the exterior of the valve with vaseline (P/N # H1GMIN017) before re-installation.

## 8.7. Upside Fittings for UPSide module supply

### 8.7.1. Metric fittings

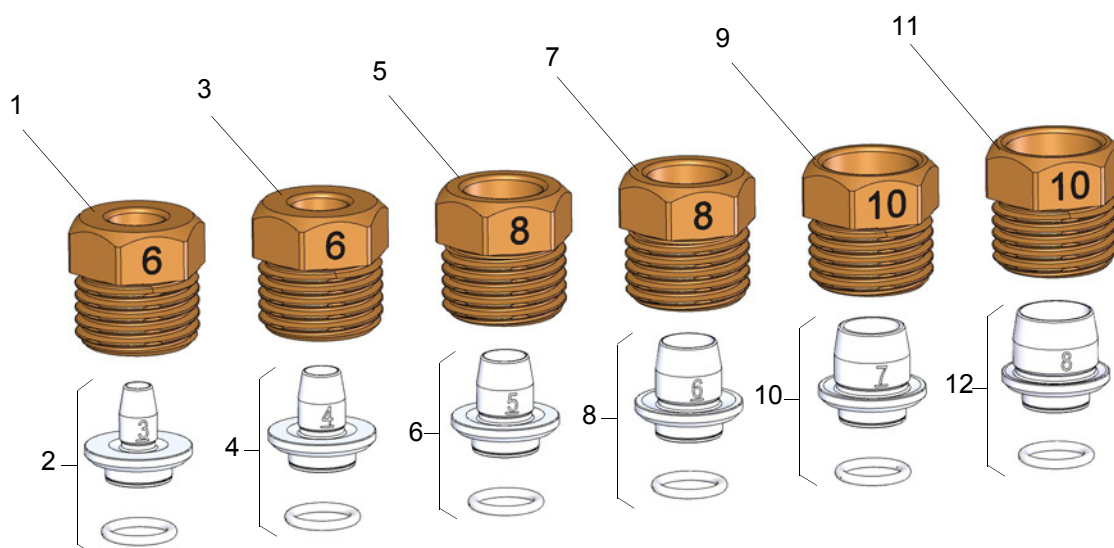

Item	Part Number	Description	Qty	Unit of Sale	Maintenance level for Spare parts (*)
1	900010895	Nut of fitting 1/4 - 6	-	1	3
2	<b>910019616</b>	<b>Nipple Dia: 3 + O- ring assembly</b>	-	<b>1</b>	<b>3</b>
3	900010895	Nut of fitting 1/4 - 6	-	1	3
4	<b>910019617</b>	<b>Nipple Dia: 4 + O- ring assembly</b>	-	<b>1</b>	<b>3</b>
5	900008770	Nut of fitting 1/4 - 8	-	1	3
6	<b>910019618</b>	<b>Nipple Dia: 5 + O- ring assembly</b>	-	<b>1</b>	<b>3</b>
7	900008770	Nut of fitting 1/4 - 8	-	1	3
8	<b>910019619</b>	<b>Nipple Dia: 6 + O- ring assembly</b>	-	<b>1</b>	<b>3</b>
9	900010486	Nut of fitting 1/4 - 10	-	1	3
10	<b>910019620</b>	<b>Nipple Dia: 7 + O- ring assembly</b>	-	<b>1</b>	<b>3</b>
11	900010486	Nut of fitting 1/4 - 10	-	1	3
12	<b>910019621</b>	<b>Nipple Dia: 8 + O- ring assembly</b>	-	<b>1</b>	<b>3</b>

(\*)

**Level 1: Standard preventive maintenance**

**Level 2: Corrective maintenance**

**Level 3: Exceptional maintenance**



**WARNING :** The performance of the UPSide CCV blocks is guaranteed only with the use of the specific fittings Sames.

## 8.7.2. Imperial fittings

### 8.7.2.1. Nuts

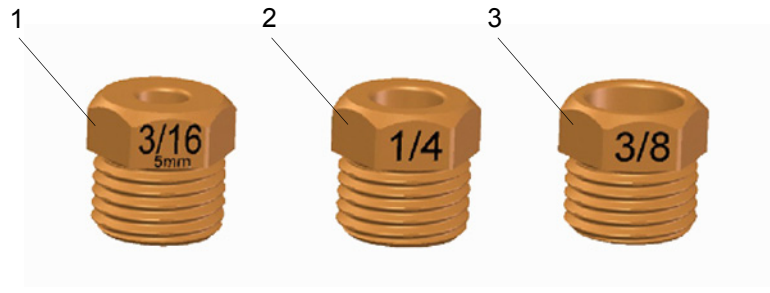

Item	Part Number	Description	Qty	Unit of Sale	Maintenance level for Spare parts (*)
1	900014325	Nut of fitting Dia.: 5 (3/16)	-	1	3
3	900014326	Nut of fitting Dia: 6.35 (1/4)	-	1	3
9	900013172	Nut of fitting Dia: 9.5 (3/8)	-	1	3

### 8.7.2.2. Nipple assemblies

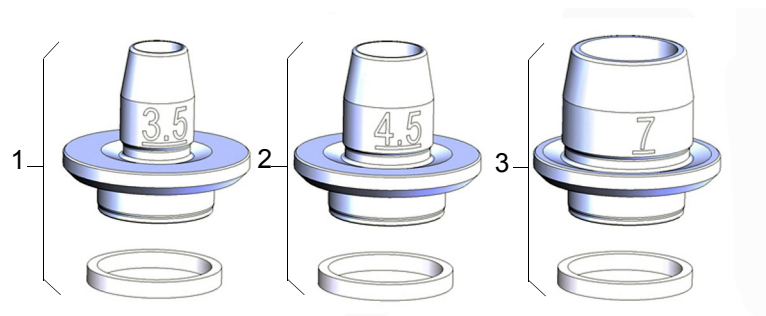

Item	Part Number	Description	Qty	Unit of Sale	Maintenance level for Spare parts (*)
1	910021498	Nipple Dia: 3.5 + O- ring assembly	-	1	3
2	910021499	Nipple Dia: 4.5 + O- ring assembly	-	1	3
3	910019620	Nipple Dia: 7 + O- ring assembly	-	1	3

(\*)

**Level 1: Standard preventive maintenance**

**Level 2: Corrective maintenance**

**Level 3: Exceptional maintenance**



### 8.8. Mini rack fitting for UPSide modules

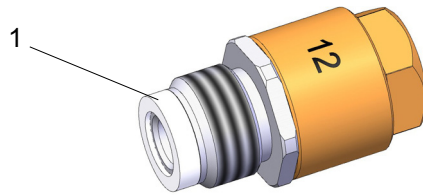

Item	Part Number	Description	Qty	Unit of Sale	Maintenance level for Spare parts (*)
	<b>910019671</b>	<b>Mini rack fitting 9 -121/4</b>	-	<b>1</b>	<b>3</b>
1	900010934	Seal	1	1	3

(\*)

**Level 1: Standard preventive maintenance**

**Level 2: Corrective maintenance**

**Level 3: Exceptional maintenance**

### 8.9. Fittings for end modules

**Nota:** Fittings must be adjusted according to the hose length and required flow rate of the installation.



**WARNING :** The rack fittings are installed on regulator blocks, junction modules and support modules. The installation of different types of fittings can degrade the performances of rinsing of circuits.

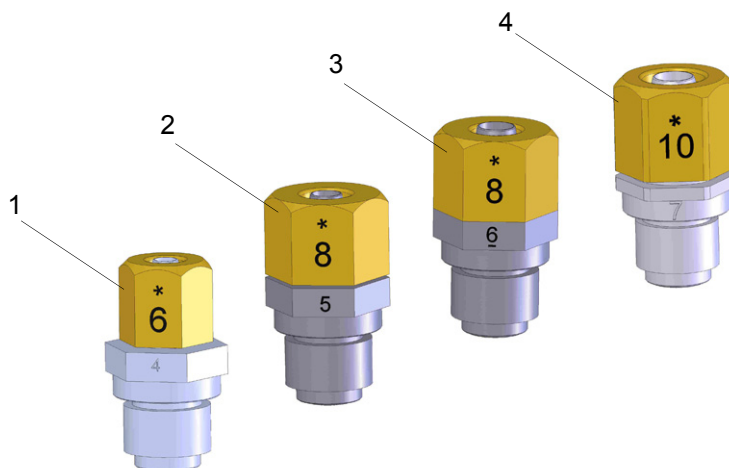

Item	Part Number	Description	Qty	Unit of Sale	Maintenance level for Spare parts (*)
1	910007346	Fitting 4/6 - G 1/4	-	1	3
2	910007347	Fitting 5/8 - G 1/4	-	1	3
3	910007348	Fitting 6/8 - G 1/4	-	1	3
4	910007349	Fitting 7/10 - G 1/4	-	1	3

(\*)

Level 1: Standard preventive maintenance

Level 2: Corrective maintenance

Level 3: Exceptional maintenance

### 8.10. Check valve for air UPside CCV module

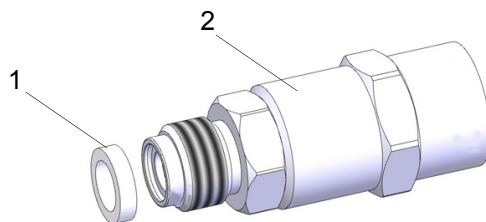

Item	Part Number	Description	Qty	Unit of Sale	Maintenance level for Spare parts (*)
1	900010934	Seal	-	1	3
2	900011207	Check valve	-	1	3