



**DOCUMENTATION - DOKUMENTATION - DOCUMENTACIÓN**

**POMPE / PUMP / PUMPE / BOMBA**

**EOS 06-R440**

**Notice / Manual / Betriebsanleitung / Libro : 582.053.110 - 1605**

*Date / Datum / Fecha : 27/05/16*

*Annule / Supersede / Ersetzt / Anula :*

*Modif. / Änderung :*

**NOTICE ORIGINALE / TRANSLATION FROM THE ORIGINAL MANUAL**  
**/ ÜBERSETZUNG DER ORIGINAL BETRIEBSANLEITUNG**  
**/ TRADUCCIÓN DEL MANUAL ORIGINAL**

***IMPORTANT : Lire attentivement tous les documents avant le stockage, l'installation ou la mise en service du matériel concerné (à usage strictement professionnel).***

***Before assembly and start-up, please read and clearly understand all the documents relating to this equipment (professional use only).***

***WICHTIGER HINWEIS: Vor Lagerung, Installation oder Inbetriebnahme des Geräts bitte sämtliche Dokumente sorgfältig lesen (Einsatz nur von geschultem Personal).***

***IMPORTANTE : Lea con atención todos los documentos antes de almacenar, instalar o poner en marcha el equipo (uso exclusivamente profesional).***

PHOTOS ET ILLUSTRATIONS NON CONTRACTUELLES. MATERIELS SUJETS A MODIFICATION(S) SANS PREAVIS.

THE PICTURES AND DRAWINGS ARE NON CONTRACTUAL. WE RESERVE THE RIGHT TO MAKE CHANGES WITHOUT PRIOR NOTICE.

ALLE IN DIESEM DOKUMENT ENTHALTENEN SCHRIFTLICHEN ANGABEN UND ABBILDUNGEN STELLEN DIE NEUESTEN

PRODUKTINFORMATIONEN DAR. WIR BEHALTEN UNS DAS RECHT VOR, JEDERZEIT OHNE VORANKÜNDIGUNG ÄNDERUNGEN VORZUNEHMEN.

LAS FOTOGRAFÍAS E ILUSTRACIONES NO SON VINCULANTES. LOS MATERIALES ESTÁN SUJETOS A CAMBIOS SIN PREVIO AVISO.

**KREMLIN - REXSON**

150, avenue de Stalingrad

93 245 - STAINS CEDEX - France

☎ : 33 (0)1 49 40 25 25      Fax : 33 (0)1 48 26 07 16

**[www.kremlin-rexson.com](http://www.kremlin-rexson.com)**



<p align="center"><b>FR</b></p> <p><b>Pour une utilisation sûre, il est de votre responsabilité de :</b></p> <ul style="list-style-type: none"> <li>• Lire attentivement tous les documents contenus dans le CD joint avant la mise en service de l'équipement,</li> <li>• D'installer, d'utiliser, d'entretenir et de réparer l'équipement conformément aux préconisations de KREMLIN REXSON ainsi qu'aux réglementations nationales et/ou locales,</li> <li>• Vous assurez que les utilisateurs de cet équipement ont été formés, ont parfaitement compris les règles de sécurité et qu'ils les appliquent.</li> </ul>	<p align="center"><b>UK</b></p> <p><b>To ensure safe use of the machinery, it is your responsibility to:</b></p> <ul style="list-style-type: none"> <li>• Carefully read all documents contained on the enclosed CD before putting the machinery into service,</li> <li>• Install, use, maintain and repair the machinery in accordance with KREMLIN REXSON's recommendations and national and/or local regulations,</li> <li>• Make sure that the users of the machinery have received proper training and that they have perfectly understood the safety rules and apply them.</li> </ul>	<p align="center"><b>DE</b></p> <p><b>Eine sichere Nutzung setzt voraus, dass Sie: :</b></p> <ul style="list-style-type: none"> <li>• alle in der CD enthaltenen Dokumente vor der Inbetriebnahme der Anlage aufmerksam lesen,</li> <li>• die Anlage im Einklang mit den Empfehlungen von KREMLIN REXSON sowie mit den nationalen und/oder lokalen Bestimmungen installieren, verwenden, warten und reparieren,</li> <li>• sich vergewissern, dass die Nutzer dieser Anlage angemessen geschult wurden, die Sicherheitsbestimmungen verstanden haben und sie anwenden.</li> </ul>
<p align="center"><b>ES</b></p> <p><b>Para una utilización segura, será de su responsabilidad:</b></p> <ul style="list-style-type: none"> <li>• leer atentamente todos los documentos que se incluyen en el CD adjunto antes de la puesta en servicio del equipo,</li> <li>• instalar, utilizar, efectuar el mantenimiento y reparar el equipo con arreglo a las recomendaciones de KREMLIN REXSON y a la normativa nacional y/o local,</li> <li>• cerciorarse de que los usuarios de este equipo han recibido la formación necesaria, han entendido perfectamente las normas de seguridad y las aplican.</li> </ul>	<p align="center"><b>IT</b></p> <p><b>Per un uso sicuro, vi invitiamo a:</b></p> <ul style="list-style-type: none"> <li>• leggere attentamente tutta la documentazione contenuta nel CD allegato prima della messa in funzione dell'apparecchio,</li> <li>• installare, utilizzare, mantenere e riparare l'apparecchio rispettando le raccomandazioni di KREMLIN REXSON, nonché le normative nazionali e/o locali,</li> <li>• accertarvi che gli utilizzatori dell'apparecchio abbiano ricevuto adeguata formazione, abbiano perfettamente compreso le regole di sicurezza e le applichino.</li> </ul>	<p align="center"><b>PT</b></p> <p><b>Para uma utilização segura, é da sua responsabilidade:</b></p> <ul style="list-style-type: none"> <li>• Ler atentamente todos os documentos incluídos no CD em anexo antes de pôr o equipamento em funcionamento,</li> <li>• Proceder à instalação, utilização, manutenção e reparação do equipamento de acordo com as preconizações de KREMLIN REXSON, bem como com outros regulamentos nacionais e/ou locais aplicáveis,</li> <li>• Assegurar-se que os utilizadores do equipamento foram devidamente capacitados, compreenderam perfeitamente e aplicam as devidas regras de segurança.</li> </ul>
<p align="center"><b>NL</b></p> <p><b>Voor een veilig gebruik dient u:</b></p> <ul style="list-style-type: none"> <li>• alle document op de bijgevoegde cd aandachtig te lezen alvorens het apparaat in werking te stellen,</li> <li>• het apparaat te installeren, gebruiken, onderhouden en repareren volgens de door KREMLIN REXSON gegeven aanbevelingen en overeenkomstig de nationale en/of plaatselijke reglementeringen,</li> <li>• zeker te stellen dat de gebruikers van dit apparaat zijn opgeleid, de veiligheidsregels perfect hebben begrepen en dat zij die ook toepassen.</li> </ul>	<p align="center"><b>SE</b></p> <p><b>För en säker användning av utrustningen ansvarar ni för följande:</b></p> <ul style="list-style-type: none"> <li>• Läs noga samtliga dokument som finns på den medföljande cd-skivan innan utrustningen tas i drift.</li> <li>• Installera, använd, underhåll och reparera utrustningen enligt anvisningarna från KREMLIN REXSON och enligt nationella och/eller lokala bestämmelser.</li> <li>• Försäkra er om att användare av denna utrustning erhållit utbildning, till fullo förstått säkerhetsföreskrifterna och tillämpar dem.</li> </ul>	<p align="center"><b>FI</b></p> <p><b>Käytön turvallisuuden varmistamiseksi velvollisuutesi on:</b></p> <ul style="list-style-type: none"> <li>• Lukea huolella kaikki CD:llä olevat asiakirjat ennen laitteiston käyttöönottoa,</li> <li>• Noudattaa laitteiston asennuksessa, käytössä, kunnossapidossa ja huollossa KREMLIN REXSON in suosituksia sekä kansallisia ja/tai paikallisia määräyksiä,</li> <li>• Varmistaa, että laitteiston käyttäjät ovat koulutettuja ja ymmärtävät täysin turvallisuusmääräykset ja miten niitä sovelletaan.</li> </ul>
<p align="center"><b>PL</b></p> <p><b>Dla zapewnienia bezpiecznego użytkowania na użytkownika spoczywa obowiązek:</b></p> <ul style="list-style-type: none"> <li>• Uważnego zapoznania się ze wszystkimi dokumentami znajdującymi się na załączonej płycie CD przed pierwszym uruchomieniem urządzenia,</li> <li>• Instalowania, użytkowania, konserwacji i naprawy urządzenia zgodnie z zaleceniami firmy KREMLIN REXSON oraz z przepisami miejscowymi,</li> <li>• Upewnienia, że wszyscy przeszkoleni użytkownicy urządzenia zrozumieli zasady bezpieczeństwa i stosują się do nich.</li> </ul>	<p align="center"><b>CS</b></p> <p><b>Pro bezpečné používání jste povinni:</b></p> <ul style="list-style-type: none"> <li>• Před uvedením zařízení do provozu si pozorně přečíst veškeré dokumenty obsažené na příloženém CD,</li> <li>• Nainstalovat, používat, udržovat a opravovat zařízení v souladu s pokyny firmy KREMLIN REXSON a s národními a/nebo místními legislativními předpisy,</li> <li>• Ujistit se, že uživatelé tohoto zařízení byli vyškoleni, že dokonale pochopili bezpečnostní pravidla a že je dodržují.</li> </ul>	<p align="center"><b>RU</b></p> <p><b>Для целей безопасного использования необходимо:</b></p> <ul style="list-style-type: none"> <li>• Ознакомиться со всеми документами, содержащимися в прилагаемом компакт-диске до ввода оборудования в эксплуатацию;</li> <li>• Устанавливать, использовать, производить техническое обслуживание и ремонт оборудования в соответствии с рекомендациями KREMLIN REXSON и национальным и/или местным законодательством;</li> <li>• Убедиться, что пользователи настоящего оборудования прошли подготовку, надлежащим образом усвоили правила безопасности и обеспечивают их соблюдение.</li> </ul>

Déclaration(s) de conformité au verso de ce document / Declaration(s) of conformity at the back of this document / Konformitätserklärung(en) auf der Rückseite dieser Unterlage / Declaración (es) de conformidad en el reverso de este documento / Dichiarazione/i di conformità sul retro del presente documento / Declaração(ões) de conformidade no verso do documento / Conformiteitsverklaring(en) op de keerzijde van dit document / Försäkran om överensstämmelse på omstående sida av detta dokument / Vaatimustenmukaisuusvakuutukset tämän asiakirjan kääntöpuolella / Deklaracja(e) zgodności na odwrocie dokumentu / Prohlášení o shodě se nachází/nacházejí na zadní straně tohoto dokumentu / Сертификат(ы) соответствия расположены на оборотной стороне настоящего документа

VALABLE JUSQU'AU 19 AVRIL 2016  
VALID UNTIL 19 APRIL 2016  
GÜLTIG BIS ZUM 19. APRIL 2016  
VALIDEZ HASTA EL 19 DE ABRIL DE 2016  
VALIDO FINO AL 19 APRILE 2016  
APLICÁVEL ATÉ 19 DE ABRIL DE 2016  
GELDIG TOT 19 APRIL 2016  
GÄLLER TILL OCH MED DEN 19 APRIL 2016  
VOIMASSA 19.4.2016 SAAKKA  
WAŻNOŚĆ DO 19 KWIETNIA 2016 R.  
PLATÍ DO 19. DUBNA 2016  
ДЕЙСТВИТЕЛЬНО ДО 19 АПРЕЛЯ 2016 ГОДА



DECLARATION CE DE CONFORMITE  
EC DECLARATION OF CONFORMITY  
EG KONFORMITÄTSERKLÄRUNG  
DECLARACIÓN CE DE CONFORMIDAD  
DICHIARAZIONE CE DI CONFORMITÀ  
DECLARAÇÃO CE DE CONFORMIDADE  
EG-VERKLARING VAN OVEREENSTEMMING  
EG-FÖRSÄKRAN OM ÖVERENSSTÄMMELSE  
EY-VAATIMUKSEN MUKAISUUSVAKUUTUS  
DEKLARACJA ZGODNOŚCI CE  
CE PROHLÁŠENÍ O SHODĚ  
ДЕКЛАРАЦИЯ СООТВЕТСТВИЯ CE

Le fabricant / The manufacturer / Der Hersteller  
/ El fabricante / Il produttore / O fabricante  
/ De fabrikant / Tillverkare / Valmistaja / Producent / Výrobce  
/ Изготовитель:

**KREMLIN REXSON**  
150, avenue de Stalingrad  
93 240 - STAINS - FRANCE  
Tél. 33 (0)1 49 40 25 25 - Fax : 33 (0)1 48 26 07 16

Déclare que le matériel désigné ci-après / Herewith declares that the equipment / erklärt hiermit, dass die / Declara que el material designado a continuación / Dichiaro che il materiale sottoindicato / Declara que o material a seguir designado / verklaart dat de hieronder aangeduide apparatuur / Kungör att den utrustning som anges här nedan / ilmoittaa, että alla mainitut laitteistot / Oświadczka, że wymienione poniżej urządzenia / Prohlašuje, že níže uvedené vybavení / Декларирует, что ниженазванное оборудование:

**POMPE A BILLE / BALL PUMP / KUGELPUMPEN / BOMBA CON BOLA**

EOS 03R440

EOS 06R440

Est conforme à la législation d'harmonisation de l'Union applicable suivante / Is in conformity with the relevant Union harmonisation legislation / Erfüllt die einschlägigen Harmonisierungsrechtsvorschriften der Union / es conforme con la legislación de armonización pertinente de la Unión / è conforme alla pertinente normativa di armonizzazione dell'Unione / in overeenstemming met de desbetreffende harmonisatiewetgeving van de Unie / med den relevanta harmoniserade unionslagstiftningen / on asiaa koskevan unionin yhdenmukaistamislainsäädännön vaatimusten mukainen / jest zgodny z odnosnymi wymaganiami unijnego prawodawstwa harmonizacyjnego / Shoduje se s následující příslušnou evropskou harmonizační legislativou / Соответствует следующим стандартизированным нормам Союза

Directive ATEX / ATEX Directive / ATEX Richtlinie / Directiva ATEX / Direttiva ATEX / Diretiva ATEX  
/ ATEX-Richtlijn / ATEX-direktivet / ATEX-direktivi / Dyrektywa ATEX / Směrnice ATEX / Директива ATEX



94/9/CE

Dominique LAGOUGE

Directeur Général / Chief Executive Officer / Generaldirektor  
/ Director General / Direttore Generale / Director Geral / Algemeen  
Directeur / Generaldirektör / Pääjohtaja / Dyrektor Naczelny  
/ Dyrektor Generalny / Generální ředitel / Генеральный директор

Fait à Stains, le / Established in Stains, on / Geschehen zu Stains, am / En Stains, a / Redatto a Stains, / Vastgesteld te Stains, / Utformat i Stains, den / Stains, Ranska, / Sporządzono w Stains, dnia / Stains, dnia / Издано в г. Стен (Stains) 12/08/2015 - 08/12/2015

**VALABLE A PARTIR DU 20 AVRIL 2016**  
**VALID FROM 20 APRIL 2016**  
**GÜLTIG AB DEM 20. APRIL 2016**  
**VALIDEZ A PARTIR DEL 20 DE ABRIL DE 2016**  
**VALIDO A PARTIRE DAL 20 APRILE 2016**  
**APLICÁVEL A PARTIR DE 20 DE ABRIL DE 2016**  
**GELDIG VANAF 20 APRIL 2016.**  
**GÄLLER FRÅN OCH MED DEN 20 APRIL 2016**  
**VOIMASSA 20.4.2016 ALKAEN**  
**WAŻNOŚĆ OD 20 KWIETNIA 2016 R.**  
**PLATÍ OD 20. DUBNA 2016**  
**ДЕЙСТВИТЕЛЬНО С 20 АПРЕЛЯ 2016 ГОДА**



**DECLARATION UE DE CONFORMITE**  
**UE DECLARATION OF CONFORMITY**  
**EU-KONFORMITÄTSEKTLÄRUNG**  
**DECLARACIÓN UE DE CONFORMIDAD**  
**DICHIARAZIONE DI CONFORMITÀ UE**  
**DECLARAÇÃO UE DE CONFORMIDADE**  
**EU-CONFORMITEITSVERKLARING**  
**EU-FÖRSÄKRAN OM ÖVERENSSTÄMMELSE**  
**EU-VAATIMUKSEN MUKAISUUSVAKUUTUS**  
**DEKLARACJA ZGODNOŚCI UE**  
**EU PROHLÁŠENÍ O SHODĚ**  
**ДЕКЛАРАЦИЯ О СООТВЕТСТВИИ НОРМАМ ЕС**

Le fabricant / The manufacturer / Der Hersteller / El fabricante / Il produttore / O fabricante / De fabrikant / Tillverkare / Valmistaja / Producent / Výrobce / Изготовитель:	<b>KREMLIN REXSON</b> 150, avenue de Stalingrad 93 240 - STAINS - FRANCE Tél. 33 (0)1 49 40 25 25 - Fax : 33 (0)1 48 26 07 16
--	--

Déclare que le matériel désigné ci-après / Herewith declares that the equipment / erklärt hiermit, dass die / Declara que el material designado a continuación / Dichiaro che il materiale sottoindicato / Declara que o material a seguir designado / verklaart dat de hieronder aangeduide apparatuur / Kungör att den utrustning som anges här nedan / ilmoittaa, että alla mainitut laitteistot / Oświadczka, że wymienione poniżej urządzenia / Prohlašuje, že níže uvedené vybavení / Декларирует, что нижеуказанное оборудование:

**POMPE A BILLE / BALL PUMP / KUGELPUMPEN / BOMBA CON BOLA**

EOS 03R440
EOS 06R440

Est conforme à la législation d'harmonisation de l'Union applicable suivante / Is in conformity with the relevant Union harmonisation legislation / Erfüllt die einschlägigen Harmonisierungsrechtsvorschriften der Union / es conforme con la legislación de armonización pertinente de la Unión / è conforme alla pertinente normativa di armonizzazione dell'Unione / in overeenstemming met de desbetreffende harmonisatiewetgeving van de Unie / med den relevanta harmoniserade unionslagstiftningen / on asiaa koskevan unionin yhdenmukaistamislainsäädännön vaatimusten mukainen / jest zgodny z odnośnymi wymaganiami unijnego prawodawstwa harmonizacyjnego / Shoduje se s následující příslušnou evropskou harmonizační legislativou / Соответствует следующим стандартизированным нормам Союза

Directive ATEX / ATEX Directive / ATEX Richtlinie / Directiva ATEX / Direttiva ATEX / Diretiva ATEX / ATEX-Richtlijn / ATEX-direktivet / ATEX-direktivi / Dyrektywa ATEX / Směrnice ATEX / Директива ATEX 	<b>2014/34/UE</b>
Procédure d'évaluation de la conformité : Module A Documentation technique (Annexe VIII) archivée par : / Conformity assessment procedure: Module A Technical documentation (ANNEX VIII) recorded by: / Verfahren zur Konformitätsbewertung: Modul A Technische Unterlagen (ANLAGE VIII) archiviert durch: / Procedimiento de evaluación de la conformidad: Módulo A Documentación técnica (ALLEGATO VIII) archivada por: / Procedura di valutazione della conformità: Modulo A Documentazione tecnica (ALLEGATO VIII) archiviata a cura di: / Procedimento de avaliação da conformidade: Módulo A Documentação técnica (ANEXO VIII) arquivada por: / Conformiteitsbeoordelingsprocedure: Module A Technische documentatie (BIJLAGE VIII) gearhiveerd door: / Förfarande för bedömning av överensstämmelse: Modul A Teknisk dokumentation (BILAGA VIII) arkiverad av: / Vaatimustenmukaisuusarviointimenetelmä: moduuli A Tekninen dokumentaatio (LIITE VIII) arkistoitu: / Procedura oceny zgodności: Moduł A Dokumentacji technicznej (ZAŁĄCZNIK VIII) zarchiwizowane przez: / Postup posuzování shody: Modul A Technická dokumentace (PŘÍLOHA VIII) archivována: / Процедура оценки соответствия: Модуль A Техническая документация (ПРИЛОЖЕНИЕ VIII), архивированная: ISSeP Zoning A. Schweitzer Rue de la Platinerie B - 7340 COLFONTAINE BELGIQUE	

Dominique LAGOUGE

Directeur Général / Chief Executive Officer / Generaldirektor  
 / Director General / Direttore Generale / Director Geral / Algemeen  
 Directeur / Generaldirektör / Pääjohtaja / Dyrektor Naczelny  
 / Dyrektor Generalny / Generální ředitel / Генеральный директор

Fait à Stains, le / Established in Stains, on / Geschehen zu Stains, am / En Stains, a / Redatto a Stains, / Vastgesteld te Stains, / Utformat i Stains, den / Stains, Ranska, / Sporządzono w Stains, dnia / Stains, dnia / Издано в г. Стен (Stains) 04/04/2016 - 04/04/2016



# INSTALLATION AND SAFETY INSTRUCTIONS

## TRANSLATION OF THE ORIGINAL MANUAL

**IMPORTANT** : Before assembly and start-up, please read and clearly understand all the documents relating to this equipment (professional use only).

*THE PICTURES AND DRAWINGS ARE NON CONTRACTUAL. WE RESERVE THE RIGHT TO MAKE CHANGES WITHOUT PRIOR NOTICE.*

### **KREMLIN - REXSON**

150, avenue de Stalingrad

93 245 - STAINS CEDEX – France

**☎** : 33 (0)1 49 40 25 25      *Fax* : 33 (0)1 48 26 07 16

**[www.kremlin-rexson.com](http://www.kremlin-rexson.com)**

# 1. SAFETY INSTRUCTIONS

## GENERAL SAFETY INSTRUCTIONS



**CAUTION** : The equipment can be dangerous if you do not follow our instructions concerning installation and servicing described in this manual and in accordance with applicable European standards and local national safety regulations.

Please carefully read all the instruction literature before operating your equipment.

**Only trained operators can use the equipment** (To acquire an essential training, please contact the "KREMLIN REXSON University" training center - Stains).

The foreman must ensure that the operator has understood the safety instructions for this equipment as well as the instructions in the manuals for the different parts and accessories.

Read carefully all instruction manuals, label markings before operating the equipment.



















Incorrect use may result in injury. This equipment is for professional use only. It must be used only for what it has been designed for. Never modify the equipment. The parts and accessories supplied must be regularly inspected. Defective or worn parts must be replaced.

**Guards (motor cover, coupling shields, connectors,...) have been designed for a safe use of the equipment.**  
**The manufacturer will not be held responsible for bodily injury or failure and / or property damage due to destruction, the overshadowing or the partial or total removal of the guards.**

**Never exceed the equipment components' maximum working pressure.**

Comply with regulations concerning safety, fire risks, electrical regulations in force in the country of final destination of the material. Use only products or solvent compatible with the parts in contact with the material (refer to data sheet of the material manufacturer).

## PICTOGRAMS

					
NIP HAZARD	WARNING MOVING ELEVATOR	WARNING MOVING PARTS	WARNING MOVING SHOVEL	DO NOT EXCEED THIS PRESSURE	HIGH PRESSURE HAZARD
					
RELIEF OR DRAIN VALVE	WARNING HOSE UNDER PRESSURE	WEAR GLASSES OBLIGATORY	WEAR OF GLOVES IS OBLIGATORY	PRODUCT VAPOR HAZARDS	WARNING HOT PARTS OR AREAS
					
ELECTRICAL HAZARD	WARNING FIRE HAZARDS	EXPLOSION HAZARDS	GROUNDING	WARNING (USER)	WARNING SERIOUS INJURIES

## FIRE - EXPLOSION - SPARKS - STATIC ELECTRICITY HAZARDS

A poor earth connection, inadequate ventilation, sparks or static electricity can cause an explosion or fire. to avoid these risks when using or servicing KREMLIN REXSON equipment, the following safety procedures must be followed :



- ensure a good earth connection and ground the parts to be handled i.e. solvents, materials, components and equipment,
- ensure adequate ventilation,
- keep working area clean and free from waste solvents, chemicals, or solid waste i.e. rags, paper and empty chemicals drums,
- never use electrical switches / power if in an atmosphere of volatile solvent vapour,
- stop working immediately in case of electrical arcs,
- never store chemicals and solvents in the working area.
- use paint whose flash point is the highest possible to prevent from any formation of gas and inflammable vapours (refer to materials' safety instructions),
- install a cover on the drums to reduce the diffusion of gas and vapours in the spraybooth.

## TOXIC PRODUCT HAZARDS

Toxic products or vapours can cause severe injury not only through contact with the body, but also if the products are ingested or inhaled. It is imperative :



- to know the material products and their risks,
- notified or hazardous materials must be stored in accordance with the regulations,
- the material must be stored in an appropriate container, never place materials in a container where there is a risk of spillage or leakage,
- a procedure must be applied for the safe disposal of waste material. It must comply with all prevailing regulations and legislations of the country where the equipment is to be used,
- protective clothing should always be worn in compliance with the material manufacturers' recommendations,
- depending on the application and chemical safety instructions, safety glasses, hearing protective earplug, gloves, foot wear, protective masks and possible breathing equipment should be worn to comply with the regulations (Refer to chapter "Safety equipment of KREMLIN selection guide).



### **CAUTION!**



It is forbidden to use material containing high concentrations of halogenated hydrocarbon solvents with **aluminium or zinc fillers** .Non-compliance with the instructions may cause explosion risk causing serious or fatal injury.

## **EQUIPMENT REQUIREMENTS**

**Guards (motor cover, coupling shields, connectors,...) have been designed for a safe use of the equipment.**

**The manufacturer will not be held responsible for bodily injury or failure and / or property damage due to destruction, the overshadowing or the partial or total removal of the guards.**

### **PUMP**



Before carrying out any work, it is imperative to read and clearly understand the disassembly and reassembly instructions before servicing. The operator must understand the equipment and the safety instructions. These instructions are available in the equipment manuals.



The air motor is designed to be mounted with a pump. Never modify any components or couplings. When operating, please keep hands away from moving parts. Before starting up the equipment, please read the PRESSURE RELIEF instructions. Please ensure that any relief or drain valves fitted are in good working order.

### **HOSES**

- Keep hoses out of circulation areas, moving parts or hot surfaces,
- Never expose product hoses to temperature higher than + 60°C / 140° F or lower than 0°C / 32° F,
- Never pull or use the hoses to move the equipment,
- Tighten all fittings as well as the hoses before operating the equipment,
- Check the hoses regularly; change them if they are damaged,
- Never exceed the working pressure (WP) indicated on the hose.

## **USED PRODUCTS**

Considering the wide variety of products that are available and can be used in our equipment it is impossible to check and make recommendations for all chemical data, regarding the risks of possible chemical attack and their long term chemical reaction

KREMLIN REXSON can not be held liable for :

- Compatibility of wetted parts,
- Risks to staff and the surroundings,
- for worn or defective parts, for faulty equipment or units, or the quality of final product.

It is the responsibility of the user to know and prevent any possible risks such as toxic vapours, fires or explosions. He shall determine the risks of immediate reactions or pursuant to repeated exposures of the staff,

KREMLIN REXSON shall not be liable for physical injuries, direct or indirect material damages caused by the use of chemicals.



## 2. HANDLING



### **Check the weight and the dimensions of the equipment**

**(☞ refer to 'Technical features' section of the instruction manual**

If weight and dimensions are too important, the unloading must be carried out by means of a forklift or any other appropriate means with a qualified personnel and in a clear horizontal area to prevent from risks of damage injury or an accident.

The centre of gravity is not in the centre of the machine : carry out by hand a stability-test after having lifted the whole at 10 cm / 3.937" maximum.

After the unloading, the handling of the whole (eg: elevator pump) is carried out by means of a pallet truck taking the bottom part of the frame.

**Remark : Each pump motor is fitted with a ring. The ring is designed for the hoisting of one pump and can not be used for the handling of the complete machine.**

## 3. STORING

Storing before installation :

- Storing ambient temperature : 0 / +50 °C / 0 / +122°F
- Protect the whole against dust, water trickling, dampness and shocks.

Storing after installation :

- Operating temperature : +15 / +35 °C / +59 / +138.2° F
- Protect the whole against dust, water trickling, dampness and shocks.

## 4. INSTALLATION OF THE EQUIPMENT

The machine is installed on a stable horizontal floor (for eg a concrete flag).



**To avoid risks caused by static electricity, the equipment as well as its components must be grounded.**

- **For the pumping equipments** (pumps, pneumatic rams, frame...), a section wire of 2.5 mm<sup>2</sup> is fixed on the material. Use this wire to connect the material to "the general ground". In case of severe environments (mechanical protection of the wire of earthing insufficient, vibrations, mobile material...) where function damages at the ground are probable, the user have to replace the provided wire of 2.5 mm<sup>2</sup> by a device more adapted to its environment (wire with a more important section, bonding strip, fixing by thimble with eyelet...),

The continuity of the ground must be controlled by a qualified electrician. If the continuity of the ground is not ensured, check the terminal, the wire and the earthing point. **Never** use the material without have solved this problem.

- In the severe cases of environments (mechanical protection of the wire of earthing insufficient, vibrations, mobile material...) where damages of the function put at the ground are probable, the user will have to replace the wire of 2.5 mm<sup>2</sup> provided, by a device more adapted to its environment (wire of more important section, bonding strip, fixing by thimble with eyelet...),
- **The gun** must be 'grounded' via a material hose or an air hose. In case of spraying by means of a gun with cup, the air hose must be conductive,
- **The materials to be painted** must also be grounded.

**All the materials situated in the working area shall be grounded.**



- **Never store** more than necessary inflammable materials inside the working area,
- The materials must be stored into **approved drums** and grounded,
- Use only grounded **metals containers** for the use of cleaning solvents,
- **Cardboard and paper are prohibited.**

## 5. MARKING OF THE EQUIPMENT

Each equipment has a marking plate.

The plate consists of the name of the manufacturer, the equipment part number and important information for correct use of the equipment (air pressure, electric power,...).

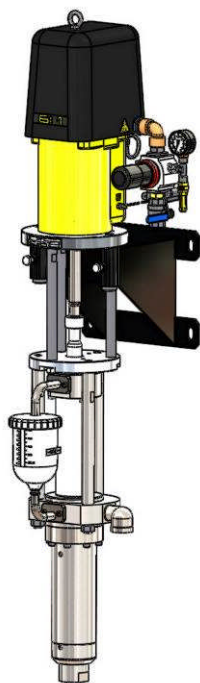

# **PUMP EOS 06-R440**

***Disassembly / Reassembly***

## **TRANSLATION FROM THE ORIGINAL MANUAL**

***IMPORTANT : Before assembly and start-up, please read and clearly understand all the documents relating to this equipment (professional use only).***

THE PICTURES AND DRAWINGS ARE NON CONTRACTUAL. WE RESERVE THE RIGHT TO MAKE CHANGES WITHOUT PRIOR NOTICE.

### **KREMLIN - REXSON**

150, avenue de Stalingrad

93 245 - STAINS CEDEX - France

☎ : 33 (0)1 49 40 25 25      Fax : 33 (0)1 48 26 07 16

**[www.kremlin-rexson.com](http://www.kremlin-rexson.com)**



**CAUTION :**

Before any action on the pump, the T lubricant should be removed, shut off the compressed air supply and depressurize the system.

**The pump is manufactured under the ATEX agreement and can not be modified. KREMLIN REXSON will not be held responsible for any failure to comply with that instruction.**

▪ **FLUID MOTOR OR AIR MOTOR REPLACEMENT (REFER TO DOC. 573.462.050 & 573.463.050)**

**Guards (air motor cover, coupling shields, housings ...) have been designed for safe use of the equipment.**

**The manufacturer will not be held responsible for bodily injury or failure and / or damage to property due to removal or partial removal of the guards**

To work on the pump, it requires to :

- Disassemble all the accessories of the pump (rod, filter), if necessary.
- The T lubricant should be removed from the upper part (A).
- Put aside the pump, if necessary (the pump is fitted with an hoisting ring).

The pump fluid section is made up of 2 sub-assemblies :

- the upper part (bellows suction sub-assembly : A)

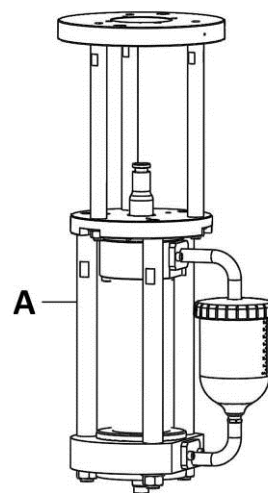

- the lower part (fluid sub-assembly: B)



The most frequently maintenance concerns this part.

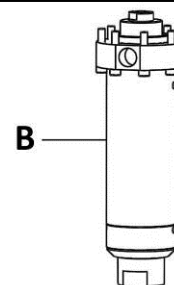

## **PUMP DRAINING**

---

**Guards (air motor cover, coupling shields, housings ...) have been designed for safe use of the equipment.  
The manufacturer will not be held responsible for bodily injury or failure and / or damage to property due to removal or partial removal of the guards**

Place a container (2L / 0.53 US gal minimum) under the drain plug.

Unscrew the drain plug with a hexagon key size 12mm.

A procedure must be applied for the safe disposal of waste material. It must comply with all prevailing regulations and legislations of the country where the equipment is to be used

### **REPLACING THE PLUG**

Clean the drain plug.



**Apply a light coating of glue to the drain plug threading (Loctite 577)**

Screw the drain plug with a hexagon key size 12mm.

## PUMP SEPARATION / COUPLING PROCEDURE

**Guards (air motor cover, coupling shields, housings ...) have been designed for safe use of the equipment.**  
**The manufacturer will not be held responsible for bodily injury or failure and / or damage to property due to removal or partial removal of the guards**

### SEPARATE THE PUMP

- Stop the pump.
- Lift the axis-lock (37).
- Lift the closing ring (19).
- Take off the bush (38) and the closing ring (19).
- Unscrew the nuts (5) from the coupling tie-rods.

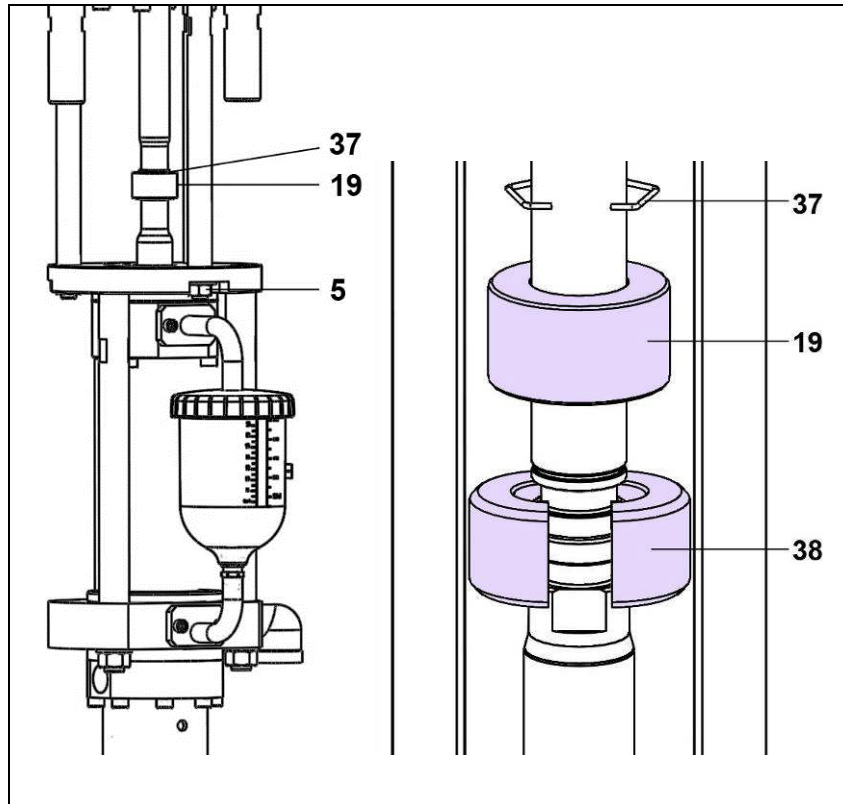

### COUPLING THE PUMP

- Unscrew the nuts (5) from the coupling tie-rods.
- After sliding the axis-lock (37) and the closing ring (19), take off the motor piston rod to bring in contact with the pump piston.
- Put the bush (38) on motor and pump piston rod ends.
- Go down the closing ring (19).
- Put the axis-lock (37).

## FILLING THE SUCTION SUB-ASSEMBLY (A) WITH T LUBRICANT

*Nota : Use only lubricant compatible with the parts in contact with the product (See data sheet of the product manufacturer).*

Use only KREMLIN REXSON T lubricant.

- Unscrew the lid from the cup (3).
- Run the pump to load the product.
- When the pump is loaded fill the T lubricant into the cup (1) until it reaches the maximum level.
- Refill with the T lubricant until the backflow into the cup ( $\approx 1.2L / 0.32$  US gal).
- Screw the lid on the cup (3).

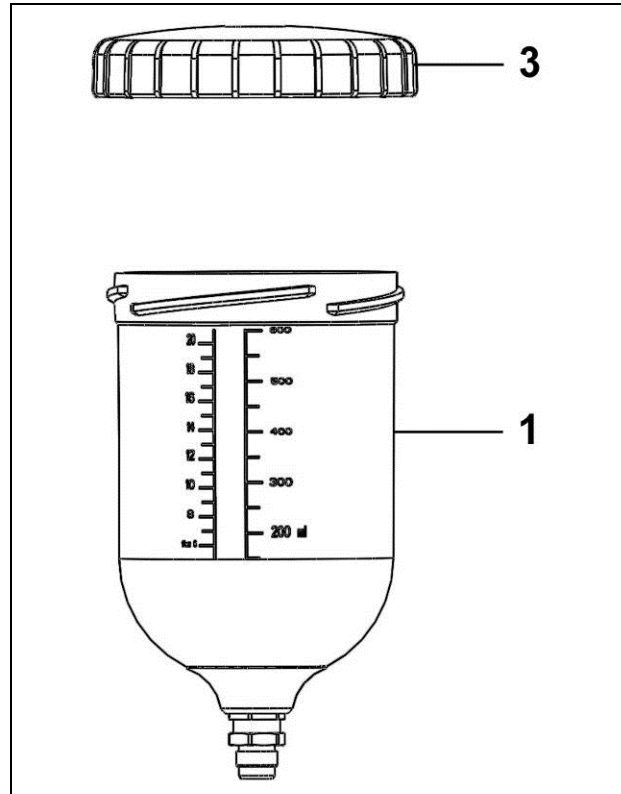

## DISASSEMBLY / REASSEMBLY OF THE FLUID SECTION

**Guards (air motor cover, coupling shields, housings ...) have been designed for safe use of the equipment.**  
**The manufacturer will not be held responsible for bodily injury or failure and / or damage to property due to removal or partial removal of the guards**

### DISASSEMBLY / REASSEMBLY OF THE FLUID SUB-ASSEMBLY (B)

*Nota : The suction valve, the cylinder, the exhaust valve can be removed or change without needing to separate the product sub-assembly (B) from the suction sub-assembly (A).*

#### ▪ SUCTION VALVE (34)

##### Disassembly

Unscrew the suction valve (34) with a 50mm wrench.

*Nota : If the cylinder (32) remains attached to the suction valve, unscrew both parts, then hold cylinder (32) by inserting a rod into the cylinder holes designed for this purpose.*

The ball (37) is secured on the valve (35) by means of a stop ring (36).

Clean the parts with an appropriate cleaning product.

##### Assembly

Reinstall the ball (37) and the stop ring (36) on the suction valve body (35).

Change the seal (28). Grease it.

 Apply grease to the suction valve body thread .

Remount the valve assembly (34) on the cylinder (32).

#### ▪ CYLINDER (32)

In order to make easier the disassembly, a hole is drilled in the cylinder (32) at each end.

Depending on the part that it is unscrewed first, insert a rod into one of these holes to unscrew the other part.

When reassembling, make sure the two seals (28) are installed. Grease them.

 Lubricate inside the cylinder (grease, type A1) and the threads to prevent damaging the mobile packing (grease, type A2) - (refer to greases in § Assembly instructions).

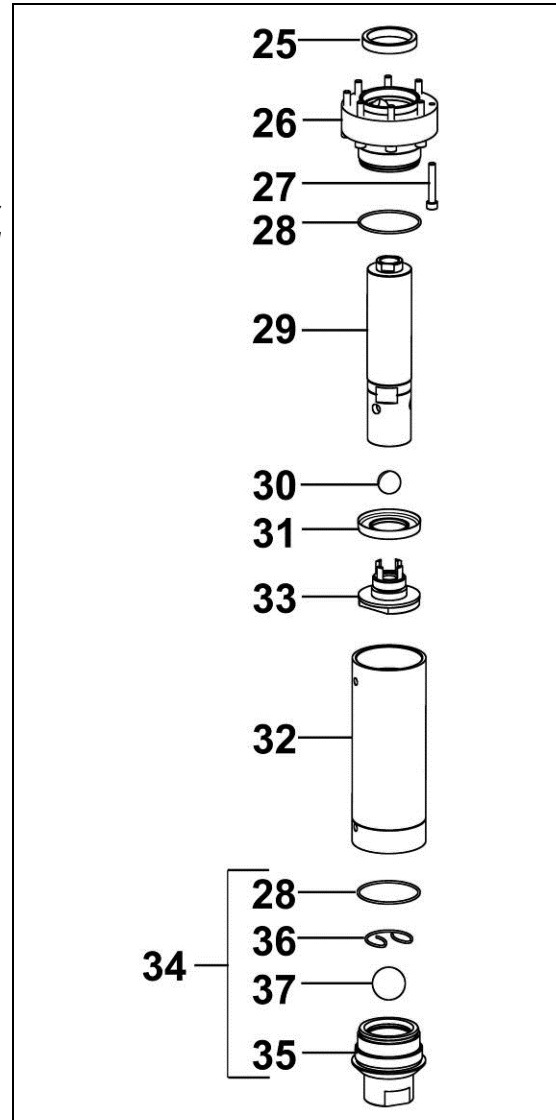



▪ **EXHAUST VALVE (33) AND CUP SEAL (31)**

**Disassembly**

Unscrew the cylinder (32) and pull it downwards..

Unscrew the exhaust valve (33) with a 58mm wrench by holding the piston (29).

Remove the ball (30),

Remove the cup seal (31).

Clean the parts.

**Assembly**

Remount a new cup seal (31),

Reinstall the ball (30) on the exhaust valve (33).

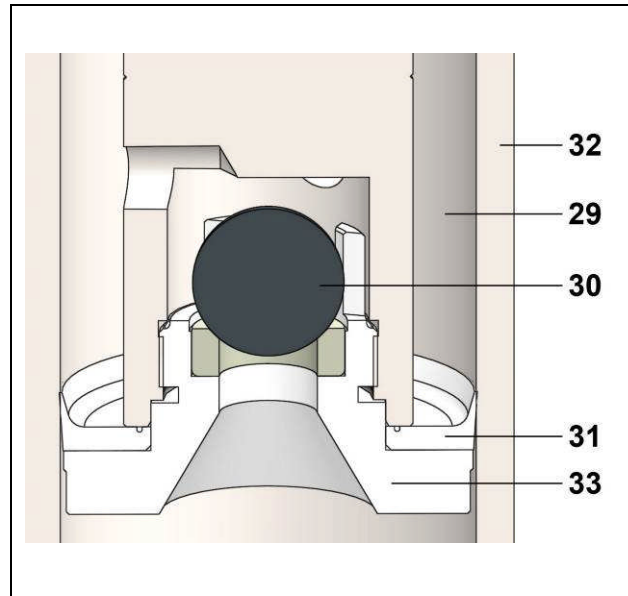

⚠ Apply a light coating of grease to the threading of exhaust valve (33) (grease, type A2).  
Screw the part in the piston lower part (29) (refer to greases in § Assembly instructions).

## DISASSEMBLY / REASSEMBLY OF THE SUCTION SECTION SUB-ASSEMBLY (A)

*Nota : The disassembling of the upper tightness seal and of the bellows requires to separate the fluid sub-assembly (B) from the suction sub-assembly (A).*

### SEPARATION PROCEDURE

Disassemble the cylinder (32). You can see the fluid section (29).

➤ You must place the piston downwards.

**⚠** Install an air pressure (from 0.2 to 0.5 bar / from 2.9 to 7.2 psi) on the air motor. When the piston is at its lower point, close the air inlet valve to prevent the piston from getting up.

Remove the 3 nuts (22), the washers (21).

Pull the suction flange (20) downwards, you can see the skirt (10).

*Nota: The cylinder (17) must keep assemble with the suction bearing (11).*

Unscrew slightly 3 screws (15).

Unscrew the skirt (10) (tools : with a 36mm wrench).

*Nota : To make easier the disassembly of the skirt, you can remove one of the 3 pump tie-rods (19).*

Slide up the skirt-bellows set to clear the access to the flat on the coupling rod (8).

**⚠ Caution : the skirt must be visible.**

By means of 2 wrenches, to separate the piston (29) from the coupling rod (8) by using the flats on the coupling rod and those on the base of the piston.

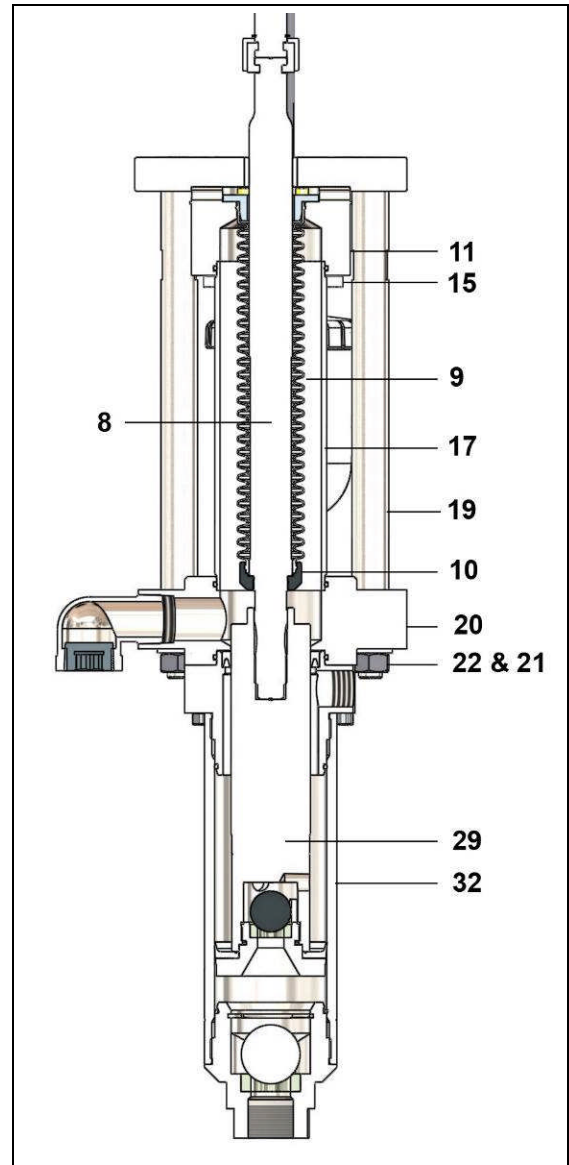

## COUPLING PROCEDURE

 Change all the seals (16 and 28) and lubricate them.

Clean the threading of the coupling rod (8) and the tapping of the pump piston (29).

Slide down the motor rod (see previous §) .

 **Apply a light coating of glue to the threading of the motor rod (Loctite 222).**

Present piston-fluid section-discharge flange assembly

Screw the motor rod into the fluid section piston. Lock the assembly.

 **Apply a light coating of glue to the fluid section piston threading (Loctite 577).**

➤ **Pull the skirt (10) downwards, and screw it onto the fluid section piston (29).**  
(tool : with a 36mm wrench).

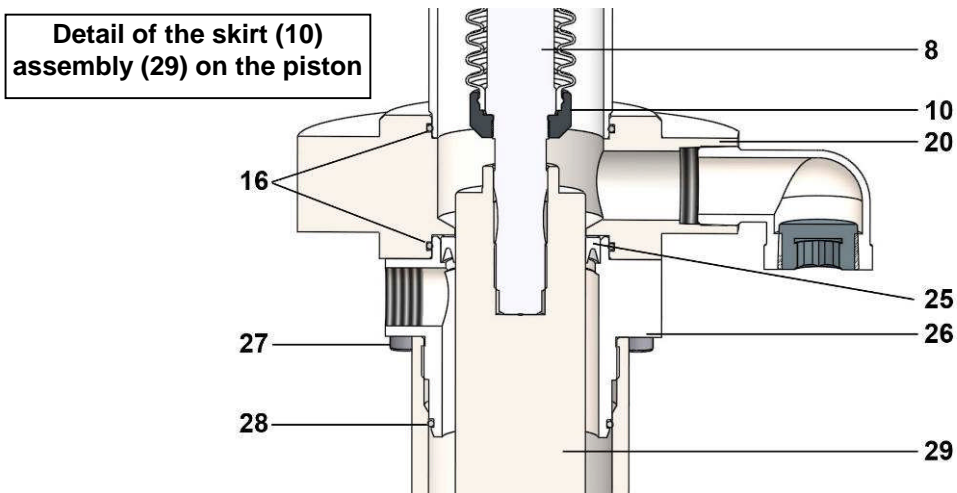

Remount the coupling rod (19) if it has been removed.

Replace the suction flange (20).

Screw the 3 screws (15).

Reinstall the 3 washers (21) and screw the nuts (22).

Remount the pump lower part as explained previously (cylinder, suction,...).

## ■ UPPER TIGHTNESS SEAL (25)

### Disassembly

Unscrew the 8 screws (27).

Separate the fluid section (A) from the suction part (B).

Remove the GT seal (25) by pulling the exhaust flange (26) downwards.

Remove the O-ring seals (16 and 28).

### Assembly

 Place a new GT seal (25) into the discharge flange (26) after having lubricated it.

➤ **Comply with the GT seal (25) installation order.**

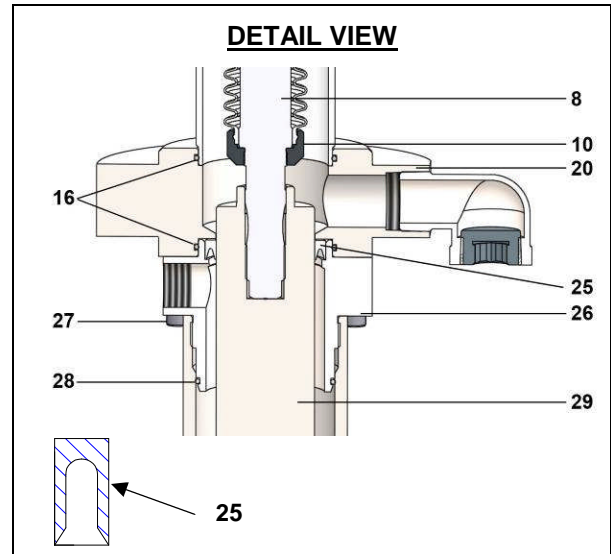

## ■ BELLOWS

This operation must be done after the separation of the lower part from the upper part of the fluid section and after the dismounting of the upper tightness seal.

In the work table, prepare assembly, which consists of fluid section piston-exhaust flange while following the procedure of the upper tightness seal (25).

### Disassembly

- Remove the cylinder (17) from the suction bearing (11).
- Separate the suction bearing (11) from the motor by removing the screws (15).
- Slide, then put aside the bellows-skirt-flange assembly.
- Remove the bellows flange (7) to take off the upper part of the bellows.
- Dismount the skirt (10).

### Assembly

On the work table, prepare a bellows-skirt-flange set. You must :

- Install a new bellows (9) into the bellows flange (7).
- When installing the bellows, push it into skirt (10).
- Install the upper bellows flange (7).
- Slide the bellows-skirt-flange assembly along the motor rod.

Orientate and tighten it on air motor base by means of the 3 screws (15).

**Nota : To make easier the reassembly, you can remove one of the three tie rods (19).**

Couple product section (B) with the suction part (A).

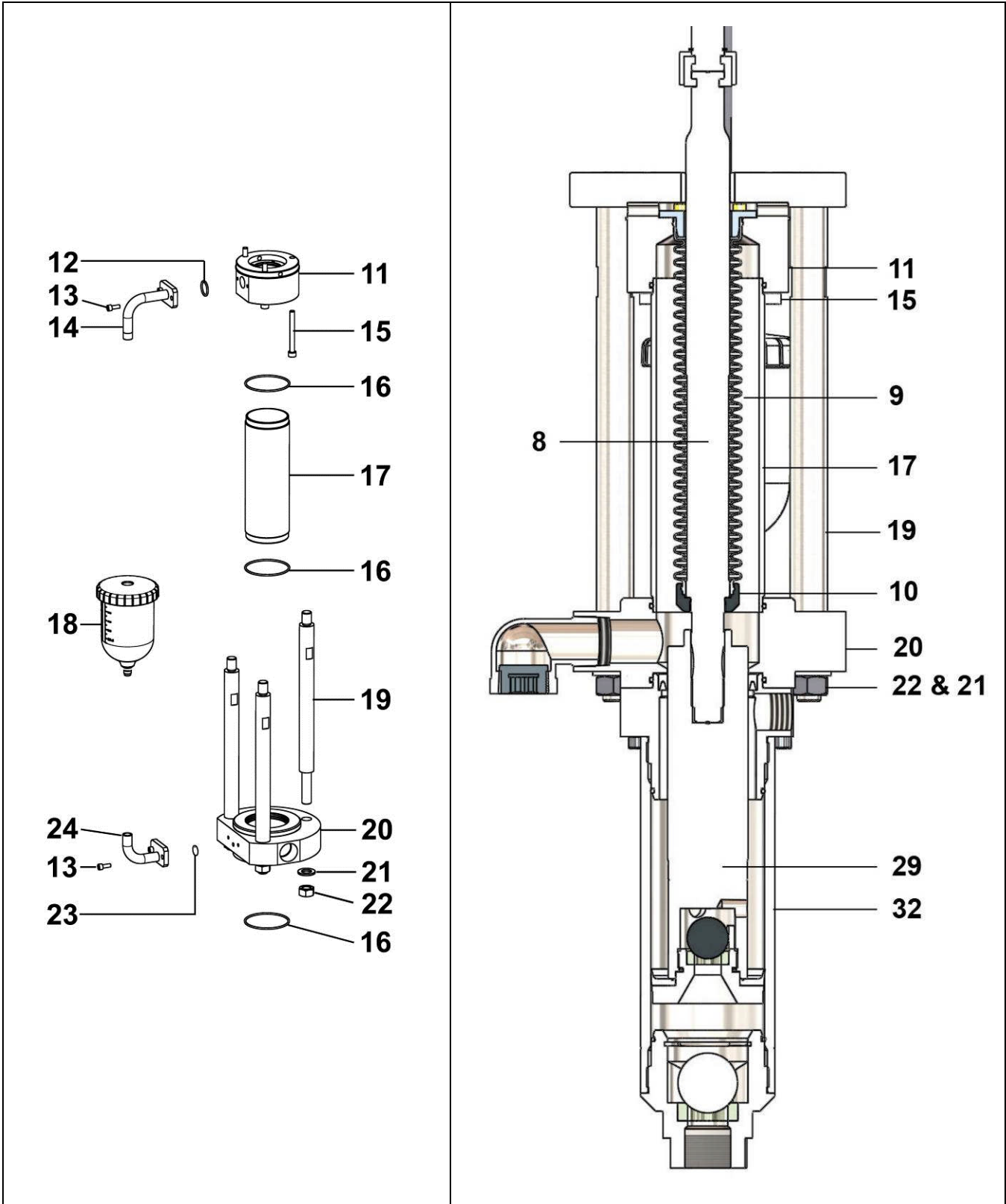

▪ CUP

**Disassembly**

- Unscrew the lid (3) from the cup (1).
- Unscrew the cup (18) from the elbow tube (24) with a 17mm wrench.
- Remove the lid (3) from the elbow tube (24).
- Separate by hand the end cup (9) and remove the assembly (5, 9, 7 and 2) from the cup.
- Remove the screen (2).
- Unscrew the nut (7) with a 8mm wrench and the washer (8) from the valve (5).
- Unscrew the valve body (4) with a 18mm wrench from the upper elbow tube (14).
- Unscrew the nut (7) with a 8mm wrench and the washer (8) from the valve body (4) and remove the spring (6) with its washer (8).

**Assembly**

- Slide the lid of the cup onto the upper elbow tube (14) and hold it in the up position.
- Screw the upper valve assembly with the valve (5), the spring (6), the washer (8), the nut (7) with a 8mm wrench and the washer (8) onto the valve body (4).
- Screw the upper valve onto the elbow tube (14) with a 18mm wrench.
- Screw the lower valve with the valve (5) and the nut (7) with a 8mm wrench onto the end cup (9).
- Place the screen (2).
- Clip manually as far as it will go the lower valve assembly into the cup.

**⚠ Apply a light coating of glue to the cup threading (Loctite 577).**

- Screw the reassembled cup (1) onto the lower elbow tube (24).
- Screw the lid (3) onto the cup (1).

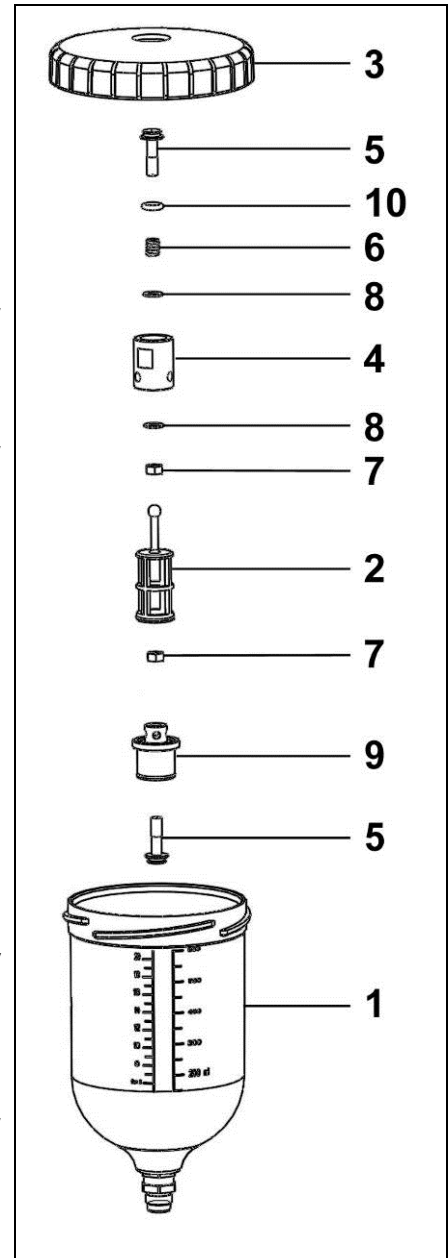

## MOTOR

### ▪ REVERSING BLOCK

**Guards (air motor cover, coupling shields, housings ...) have been designed for safe use of the equipment.**  
**The manufacturer will not be held responsible for bodily injury or failure and / or damage to property due to removal or partial removal of the guards**

The maintenance consists in changing the wetted or worn parts and to clean the parts with compatible materials without using abrasive materials that can damage them. The O-Rings are installed with "Kluber petamo" grease. Make sure the seals are not damaged, one damaged seal can lead to a motor malfunction.

### ▪ MUFLER

#### Disassembly

- Unscrew the muffler (15)

#### Assembly

- Screw the muffler (15).

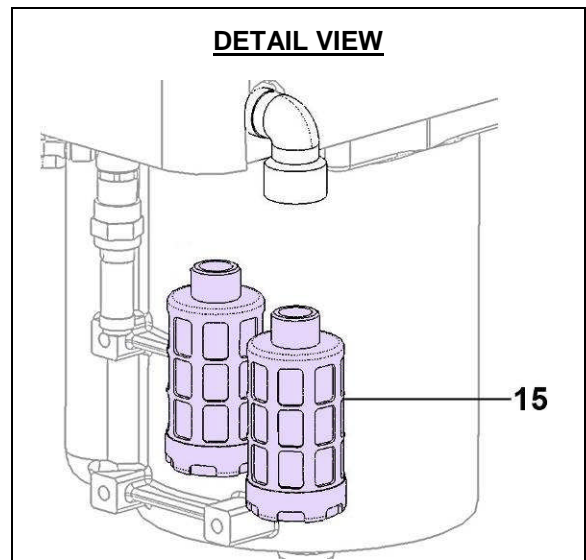

## DISCHARGE VALVE

### Disassembly

- Unscrew the discharge-valve (14).

### Assembly

**⚠** Apply a light coating of glue to the discharge valve threading (Loctite 222).

- Screw the discharge valve (14).

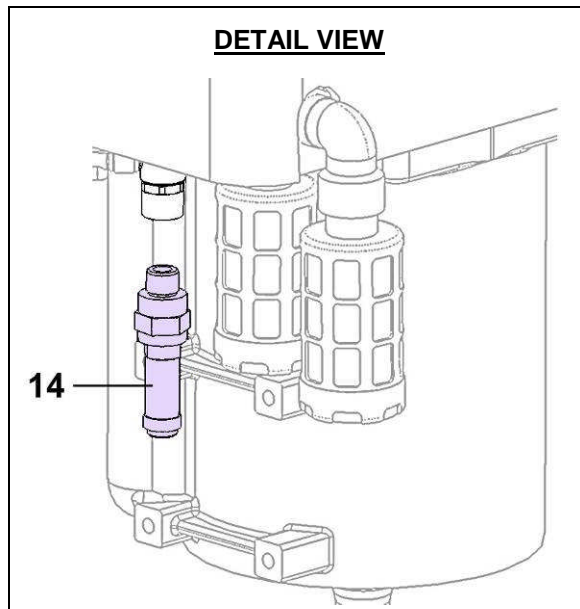

## DISTRIBUTOR, MODEL 4/2

### Disassembly

- Unscrew the hoisting ring (1) and remove the washer (2).
- Remove the cover (3).
- Unscrew the 4 screws (19) with a hexagon key size 4mm.
- Remove the distributor (10).

### Assembly

- Replace the distributor (10) on its location.
- Screw the 4 screws (19) with a hexagon key size 4mm.
- Replace the cover (3).
- Put the washer (2).
- Screw the hoisting ring (1).

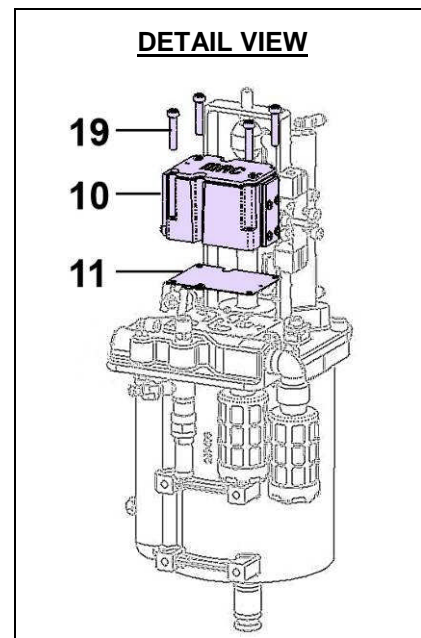



▪ **DISTRIBUTOR, MODEL 5/2 1/8"**

**Disassembly**

- Unscrew the hoisting ring (1) and remove the washer (2).
- Remove the cover (3).
- Disconnect the hoses (42).
- Unscrew the 2 screws (56) with a hexagon key size 2,5mm.
- Unscrew the 5 elbows (45) with a 10mm wrench.

**Assembly**

**⚠ Apply a light coating of glue to the elbow threading (Loctite 222).**

- Screw the 5 elbows (45) with a 10mm wrench.
- Screw the 2 screws (56) with a hexagon key size 2,5mm.
- Connect the hoses (42).
- Replace the cover (3).
- Put the washer (2).
- Screw the hoisting ring (1).

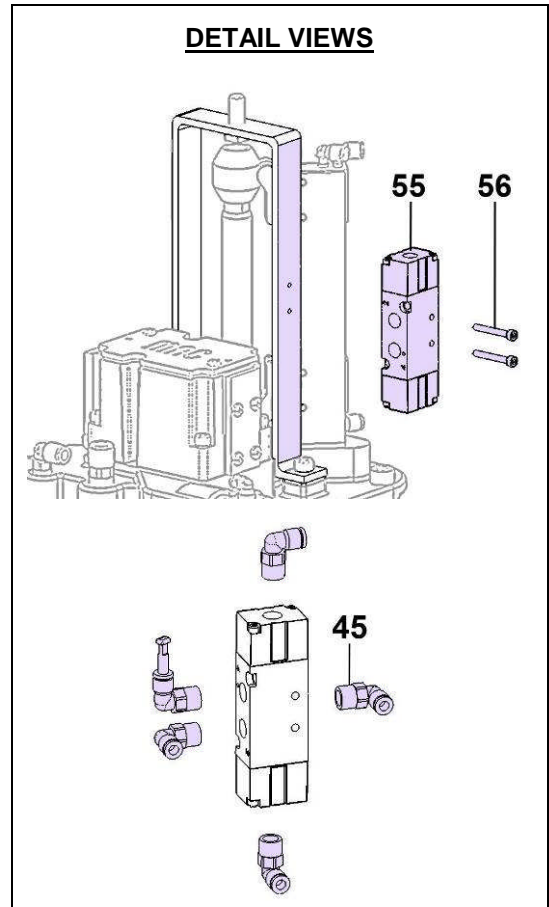

▪ **SWITCH**

**Disassembly**

- Unscrew the hoisting ring (1) and remove the washer (2).
- Remove the cover (3).
- Identify and disconnect the hoses (42).
- Unscrew the 4 screws (53) with a hexagon key size 3mm.

**Assembly**

- Screw the 4 screws (53) with a hexagon key size 3mm.
- Connect the hoses (42).
- Replace the cover (3).
- Put the washer (2).
- Screw the hoisting ring (1).

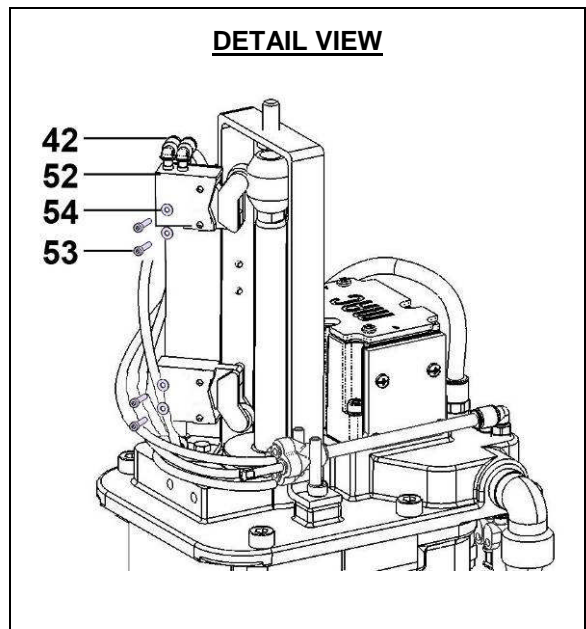

▪ **SEALS**

First remove, the axis-lock, the closing ring, the bush used for the pump separation.

**Disassembly**

- Unscrew the hoisting ring (1) and remove the washer (2).
- Remove the cover (3).
- Identify and disconnect the hoses (42).
- Remove the elbows (41).
- Unscrew the 2 screws (5) with a hexagon key size 5mm and remove the u-bolt (4).
- Unscrew the 4 screws (53) with a hexagon key size 3mm.
- Unscrew the screw (7) with a hexagon key size 4mm and remove the cam (8).
- Unscrew the 4 screws (23) with a hexagon key size 6mm and remove the cover (22).
- Remove the seal (26) with a flat screwdriver.
- Remove the piston (29) and piston rod (17).
- Remove the seal (34) with a flat screwdriver.
- Remove the ring (33) with a half round tongs.
- Remove the seal (27).
- Remove the seal (24).
- Remove the ring (30) with a half round tongs.
- Remove the scraper seal (32) with a flat screwdriver.
- Remove the seal (31) with a flat screwdriver.

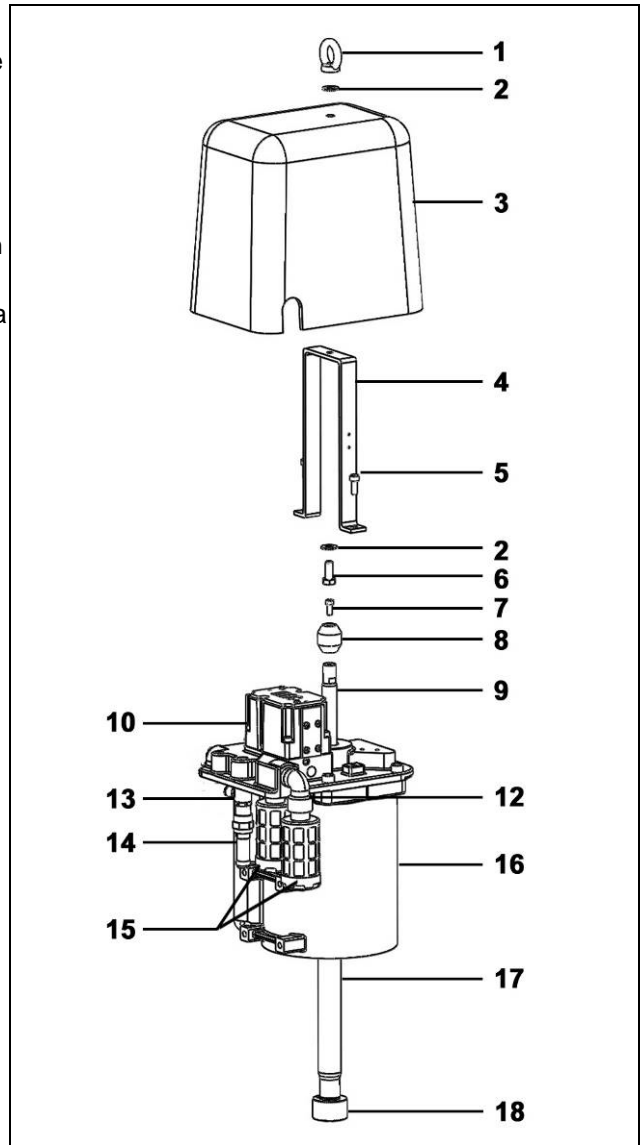

**Assembly**

**⚠ Grease slightly the seals.**

- Install the seal (31) into the cylinder.
- Install the scraper seal (32) into the cylinder.
- Install the ring (30) with a half round tongs.
- Install the seal (24) on the cylinder.
- Install the seal (27) into the cover.
- Install the seal (26) into the cover.
- Install the ring (33) with a half round tongs on the piston (29) and piston rod (17) assembly.
- Install the seal (34) in the piston grooves (29).
- Lubricate the cylinder (16).

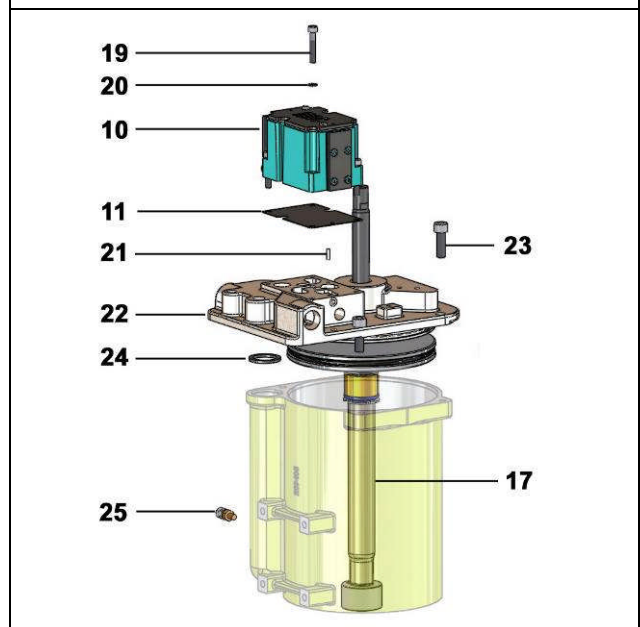

- Install the piston (29) and piston rod (17) assembly into the cylinder (16).
- Replace the cover (22) on the cylinder (16).
- Screw the 4 screws (23) with a hexagon key size 6mm.
- Install the cam (8) on the piston rod (17).
- Screw the screw (7) with a hexagon key size 4mm.
- Install the u-bolt (4) on the cover (22).
- Screw the screw (5) with a hexagon key size 5mm
- Install the elbows (41) on the switches (52).
- Connect the hoses (42) on the elbows (45).
- Replace the cover (3).
- Put the washer (2).
- Screw the hoisting ring (1).

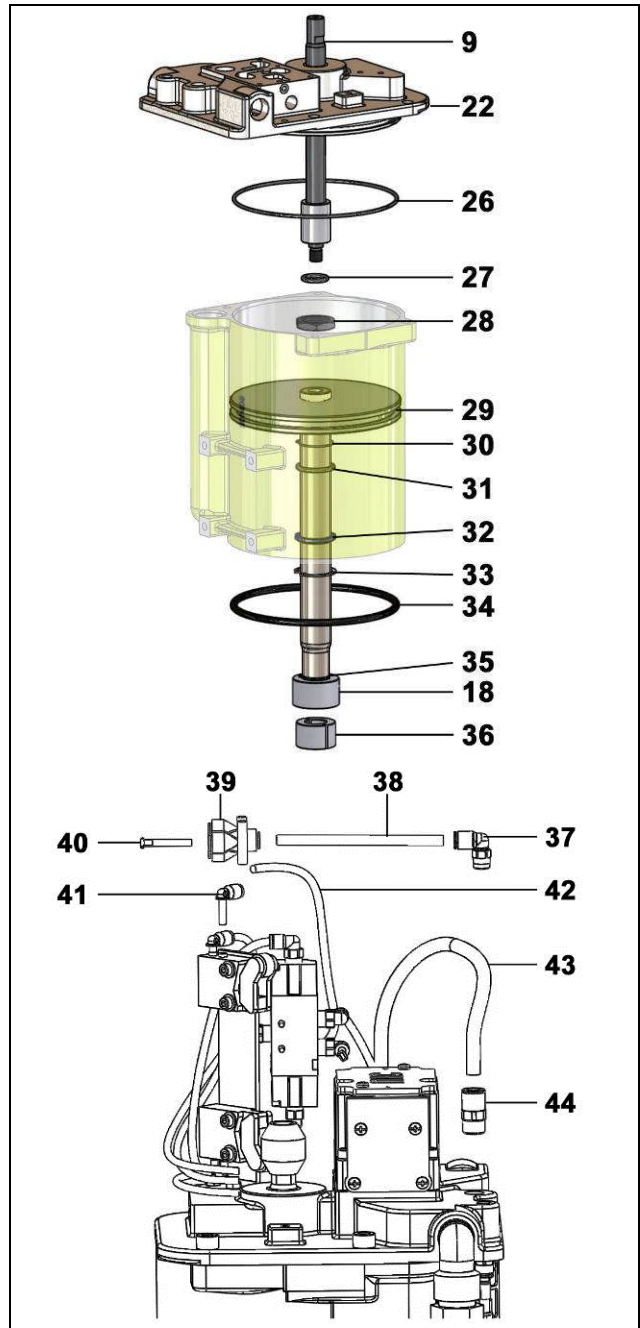

#### ▪ DEGREES OF WEAR

The wetted parts in contact with the material are subject to wear with time. It depends, of course, on the rates and duration of pump operating; also on the material handled.

Under normal operating and servicing conditions, with standard filled material not including foreign matters or chemically aggressive, the average working life can be estimated as :

- **1 million strokes for the tightness seals.**
- **10 millions strokes for the bellows.**

# FLUID SECTION ASSEMBLY INSTRUCTIONS

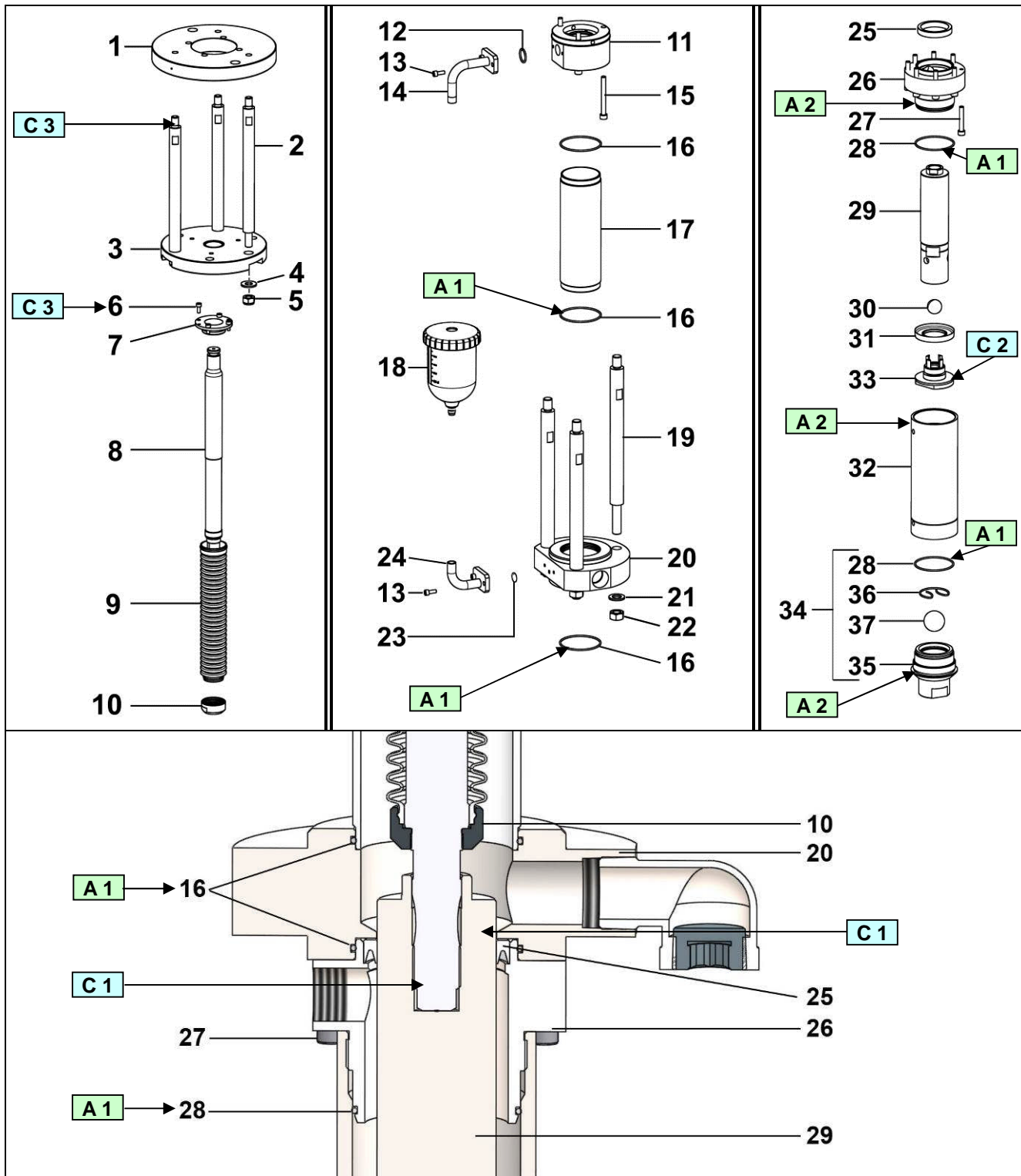

# MOTOR ASSEMBLY INSTRUCTIONS

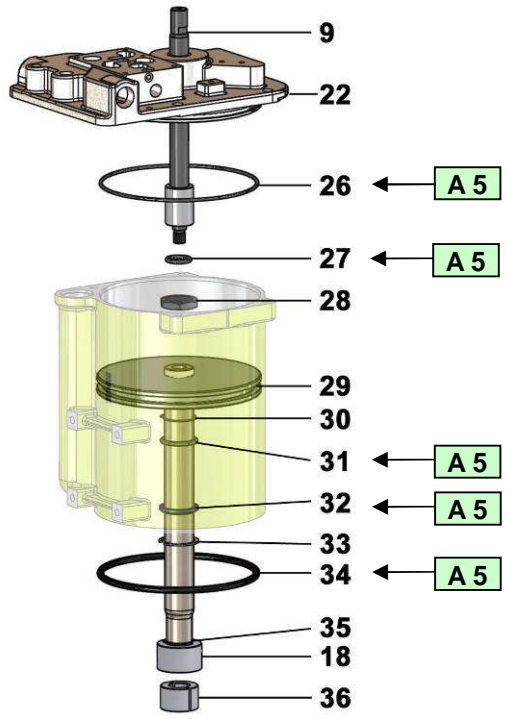
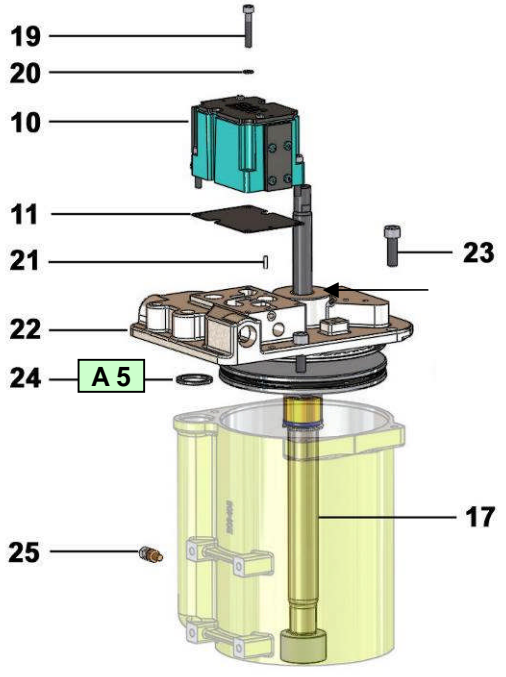
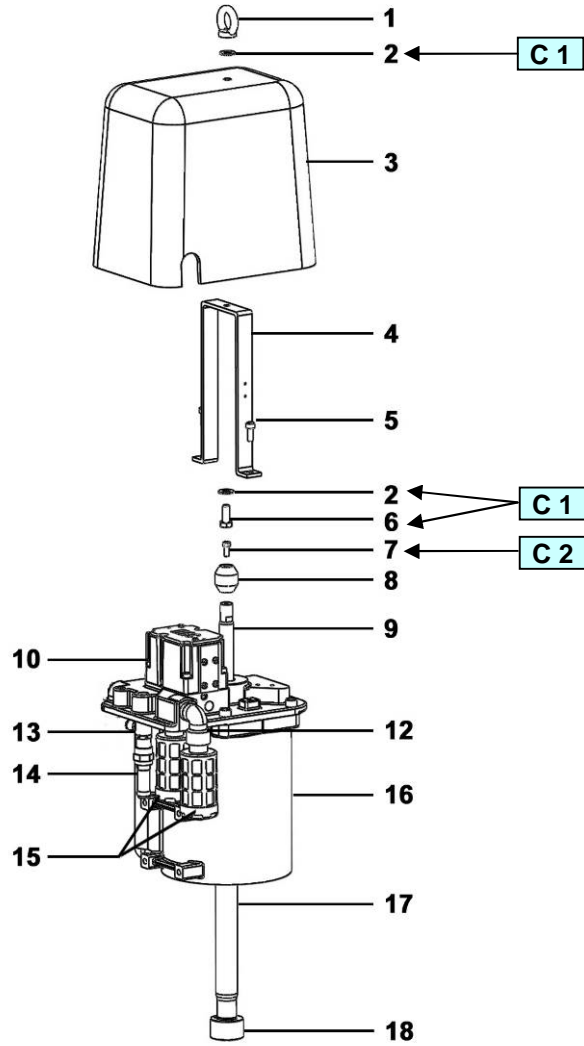

<b>Index</b>	<b>Instruction</b>	<b>Description</b>	<b>Part number</b>
<b>A 1</b>	PTFE grease	'TECHNILUB' grease (10 ml / 0.0026 US gal)	560.440.101
<b>A 2</b>	Anti-seize grease	Grease box (450 g / 0.99 lb)	560.420.005
<b>A 5</b>	High-performance lubricating grease	Grease box Kluber petamo GHY 133N (1 kg / 2.204 lb)	560.440.005
<b>C 1</b>	Medium strength Aneorobic Pipe sealant	Loctite 577 (250 ml / 0.066 US gal)	554.180.015
<b>C 2</b>	Low strength - Aneorobic Adhesive	Loctite 222 (50 ml / 0.013 US gal)	554.180.010
<b>C 3</b>	High strength - Aneorobic Adhesive	Loctite 270 (50 ml / 0.013 US gal)	554.180.004

<b>Doc. 573.464.050</b> Date/Datum/Fecha : 02/03/15 Annule/Cancel/ Ersetzt/Anula :	<b>Modif. / Änderung :</b>	<b>Pièces de rechange</b> <b>Spare parts list</b> <b>Ersatzteilliste</b> <b>Piezas de repuesto</b>
---	----------------------------	---

<b>POMPE,</b> <b>modèle EOS 06R440</b>	<b>PUMP,</b> <b>model EOS 06R440</b>
<b>PUMPE,</b> <b>Modell EOS 06R440</b>	<b>BOMBA,</b> <b>tipo EOS 06R440</b>

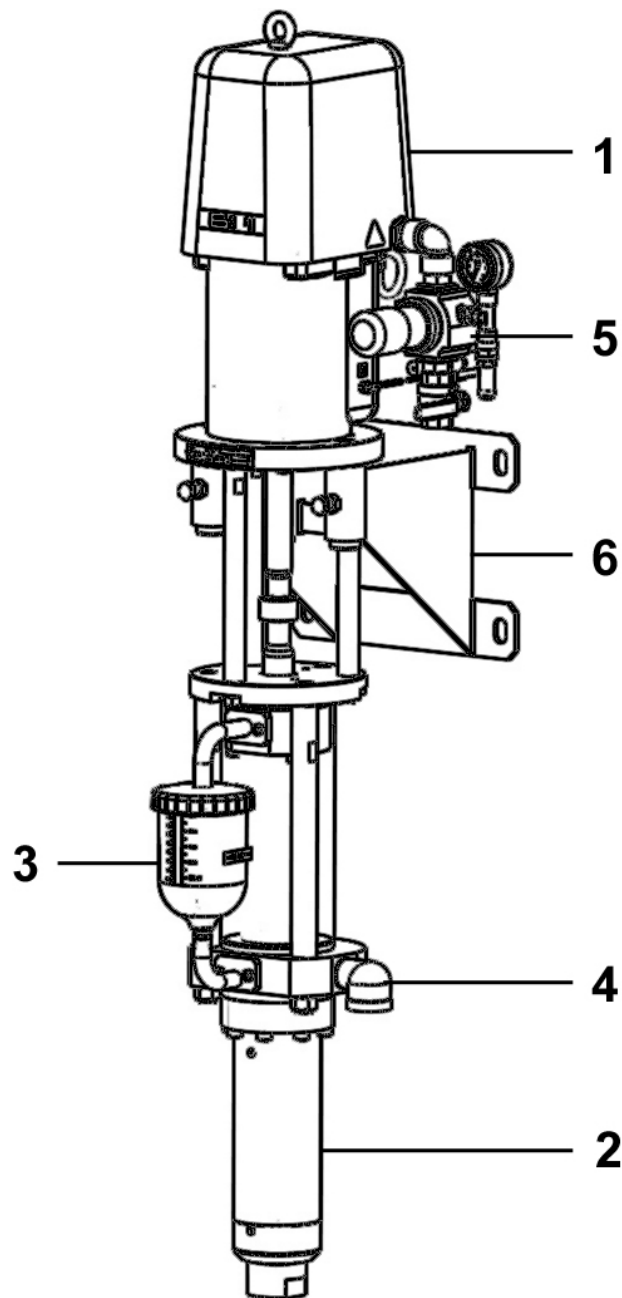

<b>POMPE MURALE, modèle EOS 06R440 (Pour produit solvanté)</b>	<b>WALL MOUNTED PUMP, model EOS 06R440 (For solvent material)</b>	<b>#</b>
<b>WANDANLAGE, Modell EOS 06R440 (Für Lösemittel Materialien)</b>	<b>BOMBA MURAL, tipo EOS 06R440 (Para producto disolventado)</b>	<b>151.864.100</b>

<b>POMPE MURALE, modèle EOS 06R440 (Pour produit hydro)</b>	<b>WALL MOUNTED PUMP, model EOS 06R440 (For hydro material)</b>	<b>#</b>
<b>WANDANLAGE, Modell EOS 06R440 (Für Wasser Materialien)</b>	<b>BOMBA MURAL, tipo EOS 06R440 (Para producto hidro)</b>	<b>151.864.300</b>

**Pièces communes - Common parts - Gleiche Teile - Partes comunes**

Ind	#	Désignation	Description	Bezeichnung	Denominación	Qté
-	NC / NS	Pompe EOS 06R440 nue	Bare pump, model EOS 06R440	Pumpe Modell, EOS 06R440	Bomba sola, tipo EOS 06R440	1
*1	146 310 200	▪ Moteur 3000-100 (voir Doc. 573.463.050)	▪ Motor, model 3000-100 (refer to Doc. 573.463.050)	▪ Motor, 3000-100 (siehe Dok. 573.463.050)	▪ Motor, tipo 3000-100 (consultar Doc. 573.463.050)	1
*3	144 990 530	▪ Godet équipé (voir Doc. 573.465.050)	▪ Cup assembly (refer to Doc. 573.465.050)	▪ Kompletter Behälter (siehe Dok. 573.465.050)	▪ Bote equipado (consultar Doc. 573.465.050)	1
-	906 314 219	Bouchon 1"	Plug, model 1"	Stopfen, 1"	Tapón, tipo 1"	1
4	905 210 404	Coude MF 1"	Elbow, model MF 1"	Winkelnippel, AG/IG 1"	Codo, tipo MH 1"	1
5	016 480 000	Détendeur d'air 3/4 0 - 10 bar - volant rouge	Air regulator, model 3/4 0 - 10 bar / 0 - 145.1 psi - red knob	Druckminderer, 3/4 0 - 10 bar (Rote Stellglocke)	Manorreductor de aire, tipo 3/4 0 - 10 bar - pomo rojo	1
6	9 015	Support de pompe	Pump bracket	Wandhalterung	Soporte de bomba	1

**Pièces spécifiques - Specific parts - Spezifische Teile - Partes específicas**

**pour produit solvanté / for solvent material / für Lösemittel Materialien / para producto disolventado**

Ind	#	Désignation	Description	Bezeichnung	Denominación	Qté
*2	144 990 500	▪ Hydraulique R 440 (voir Doc. 573.462.050)	▪ Fluid section, model R 440 (refer to Doc. 573.462.050)	▪ Hydraulikteil R 440 (siehe Dok. 573.462.050)	▪ Hidráulica, tipo R 440 (consultar Doc. 573.462.050)	1



**Pièces spécifiques - Specific parts - Spezifische Teile - Partes específicas**

***pour produit hydro / for hydro material / für Wasser Materialien / para producto hidro***

<b>Ind</b>	<b>#</b>	<b>Désignation</b>	<b>Description</b>	<b>Bezeichnung</b>	<b>Denominación</b>	<b>Qté</b>
*2	144 990 600	▪ Hydraulique R 440 (voir Doc. 573.462.050)	▪ Fluid section, model R 440 (refer to Doc. 573.462.050)	▪ Hydraulikteil R 440 (siehe Dok. 573.462.050)	▪ Hidráulica, tipo R 440 (consultar Doc. 573.462.050)	1

\* Pièces de maintenance préconisées

\* Preceding the index number denotes a suggested spare part.

\* Bezeichnete Teile sind empfohlene Ersatzteile.

\* Piezas de mantenimiento preventivas.

N C : Non commercialisé.

N S : Denotes parts are not serviceable.

N S : Bezeichnete Teile gibt es nicht einzeln, sondern nur komplett.

N S : no suministrado.

<b>Doc. 573.463.050</b> Date/Datum/Fecha : 26/02/15 Annule/Cancel/ Ersetzt/Anula	<b>Modif. / Änderung :</b>	<b>Pièces de rechange</b> <b>Spare parts list</b> <b>Ersatzteilliste</b> <b>Piezas de repuesto</b>
---	----------------------------	---

<b>MOTEUR,</b> <b>modèle 3000-100</b>	<b>MOTOR,</b> <b>model 3000-100</b>
<b>MOTOR,</b> <b>Modell 3000-100</b>	<b>MOTOR,</b> <b>tipo 3000-100</b>

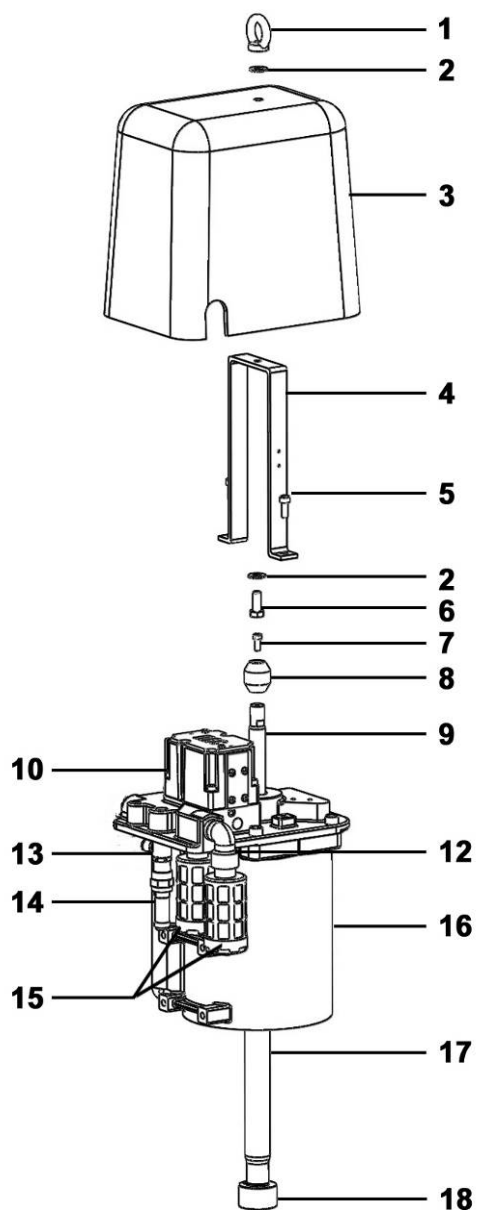

<b>MOTEUR, modèle 3000-100</b>	<b>MOTOR model 3000-100</b>	<b>#</b>
<b>MOTOR Modell 3000-100</b>	<b>MOTOR, tipo 3000-100</b>	<b>146.310.200</b>

**Détails - Details - Einzelheiten - Detalles**

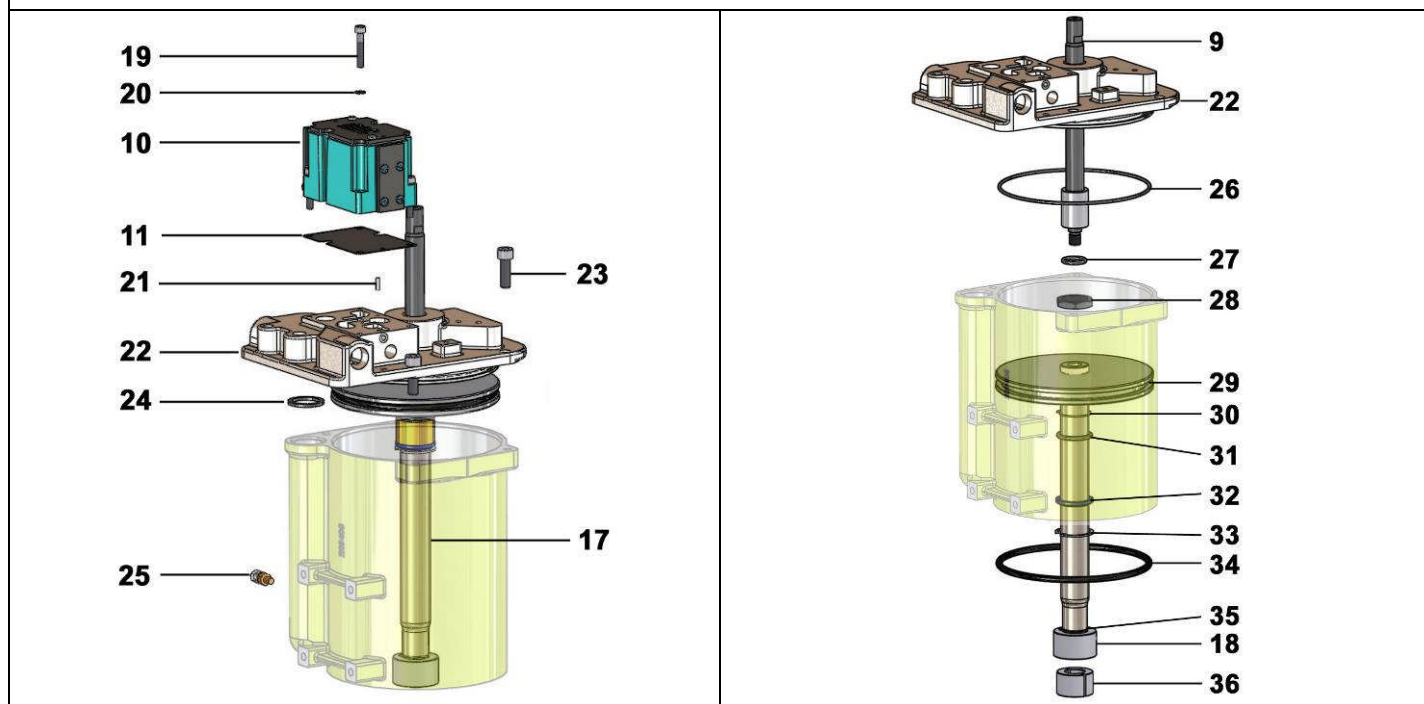

Ind	#	Désignation	Description	Bezeichnung	Denominación	Qté
1	91 421	Anneau de levage	Hoisting ring	Ringsschraube	Anillo de sujeción	1
2	963 040 019	Rondelle MU 8	Washer, model MU 8	Scheibe, MU 8	Arandela, tipo MU 8	2
3	NC / NS	Capot	Cover	Haube	Capó	1
4	210 286	Etrier	U-bolt	Halterung	Tirante	1
5	933 151 196	Vis CHc M 6 x 16	Screw, model CHc M 6 x 16	Schraube, CHc M 6 x 16	Tornillo, tipo CHc M 6 x 16	2
6	933 011 279	Vis HM 8 x 20	Screw, model HM 8 x 20	Schraube, HM 8 x 20	Tornillo, tipo HM 8 x 20	1
7	88 121	Vis CHc M 5 x 12	Screw, model CHc M 5 x 12	Schraube, CHc M 5 x 12	Tornillo, tipo CHc M 5 x 12	1
8	210 444	Came	Cam	Nocken	Brida de ajuste	1
9	146 310 203	Tige d'inversion	Reversing rod	Umsteuerstange	Eje de inversión	1
*10	146 310 092	Distributeur 4/2	Distributor, model 4/2	4/2 Wege Pneum. Ventil	Distribuidor, tipo 4/2	1
11	NC / NS	Joint d'embase	Base seal	Grundplattendichtung	Junta de base	1
12	NC / NS	Coude MF 1/2"	Elbow, model MF 1/2"	Winkelnippel, AG/IG 1/2"	Codo, tipo MH 1/2"	2

Ind	#	Désignation	Description	Bezeichnung	Denominación	Qté
13	552 542	Raccord 1/4" G	Fitting, 1/4" G	Anschluss 1/4" G	Racor, tipo 1/4" G	1
*14	903 080 401	Soupape de décharge	Discharge-valve	Sicherheitsventil	Válvula de seguridad	1
*15	146 310 091	Silencieux	Muffler	Schalldämpfer	Silenciador	2
16	209 405	Cylindre	Cylinder	Zylinder	Cilindro	1
17	210 441	Tige de piston	Piston rod	Kolbenstange	Eje de pistón	1
18	205 094	Bague de fermeture	Closing ring	Hülse	Anillo de cierre	1
19	NC / NS	Vis CHc M 5 x 30	Screw, model CHc M 5 x 30	Schraube, CHc M 5 x 30	Tornillo, tipo CHc M 5 x 30	4
20	NC / NS	Rondelle WZ 5	Washer, model WZ 5	Scheibe, M5	Arandela, tipo WZ 5	4
21	NC / NS	Goupille	Pin	Splint	Pasador	1
22	NC / NS	Couvercle	Cover	Deckel	Tapa	1
23	88 152	Vis CHc M 8 x 25	Screw, model CHc M 8 x 25	Schraube, CHc M 8 x 25	Tornillo, tipo CHc M 8 x 25	4
24	NC / NS	Joint plat	Flat seal	Flachdichtung	Junta plana	1
25	055 680 006	Borne de mise à la terre équipée	Earth terminal assembly	Erdungsanschluss montiert	Toma de tierra equipada	1
26	NC / NS	Joint torique	O-Ring	O-Ring Dichtung	Junta tórica	1
27	NC / NS	Joint	Seal	Dichtung	Junta	1
28	210 442	Ecrou	Nut	Mutter	Tuerca	1
*29	209 407	Piston	Piston	Kolben	Pistón	1
30	NC / NS	Circlips	Ring	Sicherungsring	Anillo truarc	1
31	NC / NS	Joint NBR	NBR seal	NBR Dichtung	Junta NBR	1
32	NC / NS	Joint racleur	Scraper seal	Abstreifring	Junta rascadora	1
33	NC / NS	Circlips	Ring	Sicherungsring	Anillo truarc	1
34	NC / NS	Joint torique (piston)	O-Ring (piston)	O-Ring Dichtung (Kolben)	Junta tórica (pistón)	1
35	90 040	Frein d'axe	Axis-lock	Sicherungsring	Freno de eje	1
36	209 394	Coquille	Bush	Kupplung	Coquilla	1

## Détails - Details - Einzelheiten - Detalles

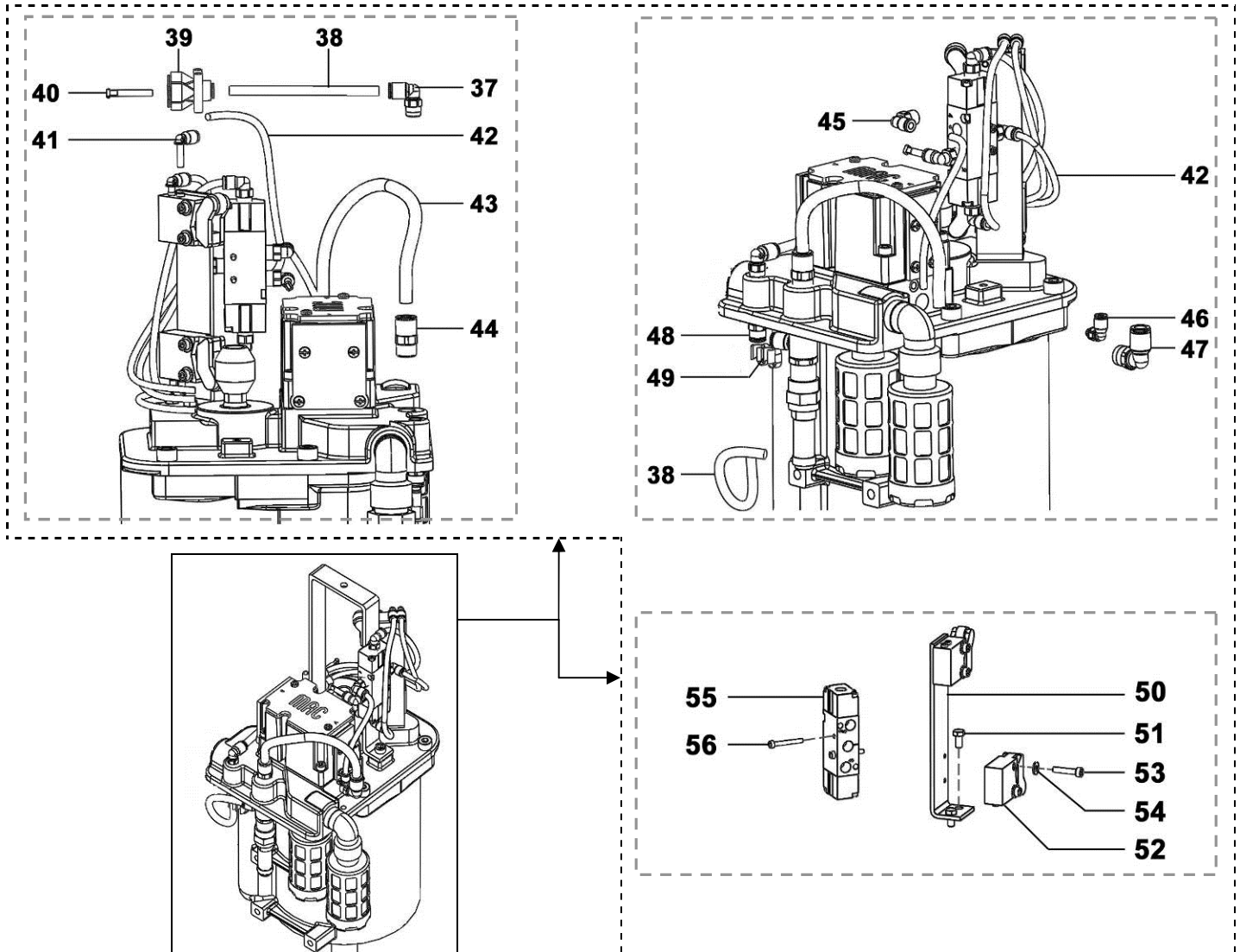

Ind	#	Désignation	Description	Bezeichnung	Denominación	Qté
37	905 120 902	Coude M 1/8" G	Elbow, M 1/8" G	Winkelnippel AG 1/8" G	Codo, tipo M 1/8" G	1
38	NC / NS	Tuyau PU 4x6 (lg. 0,20 m)	Hose PU 4x6 (lg. 0.20 m / 7.87")	Schlauch PU 4x6 (Länge: 0,20 m)	Tubería PU 4x6 (0,20 m de largo)	1
39	552 226	Raccord Y T 4x6	Fitting, Y T 4x6	Y-Anschluss für 4x6	Racor, tipo Y T 4x6	1
40	905 120 937	Bouchon pour tube	Tube plug	Verschlussstopfen für Steckanschluss	Tapón de tubo	2
41	905 120 983	Coude MF T 2x4	Elbow, MF T 2x4	Winkelnippel A/I für 2x4	Codo, tipo MH T 2x4	4
42	NC / NS	Tuyau PU 2,5x4 (lg. 25 m)	Hose PU 2,5x4 (lg. 25 m / 82.02 ft)	Schlauch PU 2,5x4 (Länge: 25 m)	Tubería PU 2,5x4 (25 m de largo)	1
43	NC / NS	Tuyau PU 6x8 (lg.100m)	Hose PU 6x8 (lg. 100 m / 328.1 ft)	Schlauch PU 6x8 (Länge: 100 m)	Tubería PU 6x8 (100 m de largo)	1

Ind	#	Désignation	Description	Bezeichnung	Denominación	Qté
44	905 120 904	Raccord droit 1/4"	Straight fitting, model 1/4"	Gerader Nippel 1/4"	Racor recto, tipo 1/4"	1
45	905 120 926	Coude M 1/8" G	Elbow, model M 1/8" G	Winkelnippel AG 1/8" G	Codo, tipo M 1/8" G	5
46	552 260	Coude M 5 G	Elbow, model M 5 G	Winkelnippel M 5 AG	Codo, tipo M 5	1
47	905 120 912	Coude M 1/4" G	Elbow, model M 1/4" G	Winkelnippel AG 1/4" G	Codo, tipo M 1/4" G	1
48	905 124 901	Raccord droit 1/8"	Straight fitting, model 1/8"	Gerader Nippel 1/8"	Racor recto, tipo 1/8"	1
49	91 723	Clip Ø 6	Clip, model Ø 6	Clip Ø 6	Clip, tipo Ø 6	2
50	146 310 202	Equerre	Bracket	Haltewinkel	Escuadra	1
51	933 011 143	Vis HM 5x10	Screw, model HM 5x10	Schraube HM 5x10	Tornillo, tipo HM 5x10	2
*52	151 800 002	Interrupteur (x 2)	Switch (x 2)	Endschalter (2x)	Interruptor (x 2)	1
53	933 151 273	Vis CHc M 4x20	Screw, model CHc M 4x20	Schraube CHc M 4x20	Tornillo, tipo CHc M 4x20	4
54	963 040 012	Rondelle MU 4	Washer, model MU 4	Scheibe MU 4	Arandela, tipo MU 4	4
*55	91 424	Distributeur 5/2 1/8"	Distributor, model 5/2 1/8"	5/2 Wege Ventil 1/8"	Distribuidor, tipo 5/2 1/8"	1
56	932 151 326	Vis CHc M 3x25	Screw, model CHc M 3x25	Schraube CHc M 3x25	Tornillo, tipo CHc M 3x25	2

Ind	#	Désignation	Description	Bezeichnung	Denominación	Qté
*	146 310 090	Pochette de joints moteur (Ind. 24, 26, 27, 30, 31, 32, 33, 34)	Seal kit air motor (Ind. 24, 26, 27, 30, 31, 32, 33, 34)	Dichtungssatz für Luftmotor (Pos. 24, 26, 27, 30, 31, 32, 33, 34)	Bolsa de juntas motor (Índ. 24, 26, 27, 30, 31, 32, 33, 34)	1
*	146 320 094	Kit pneumatique (Ind. 52, 55)	Pneumatic kit (Ind. 52, 55)	Pneumatik Kit (Pos. 52, 55)	Kit neumático (Índ. 52, 55)	1

\* Pièces de maintenance préconisées.

\* Preceding the index number denotes a suggested spare part.

\* Bezeichnete Teile sind empfohlene Ersatzteile.

\* Piezas de mantenimiento preventivas.

N C : Non commercialisé.

N S : Denotes parts are not serviceable.

N S : Bezeichnete Teile gibt es nicht einzeln, sondern nur komplett.

N S : no suministrado.

<b>Doc. 573.462.050</b> Date/Datum/Fecha : 19/02/15 Annule/Cancela/ Ersetzt/Anula :	<b>Modif. / Änderung :</b>	<b>Pièces de rechange</b> <b>Spare parts list</b> <b>Ersatzteilliste</b> <b>Piezas de repuesto</b>
--	----------------------------	---

<b>HYDRAULIQUE,</b> <b>modèle R 440</b>	<b>FLUID SECTION,</b> <b>model R 440</b>
<b>HYDRAULIKTEIL,</b> <b>Modell R 440</b>	<b>HIDRÁULICA,</b> <b>tipo R 440</b>

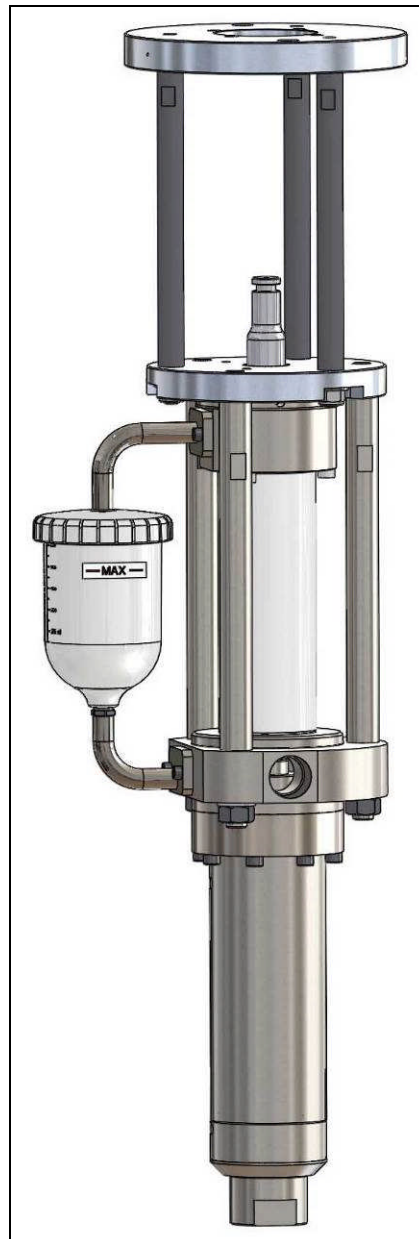

HYDRAULIQUE, modèle R 440 (Pour produit solvanté)	FLUID SECTION model R 440 (For solvent material)	#
HYDRAULIKTEIL Modell R 440 (Für Lösemittel Materialien)	HIDRÁULICA, tipo R 440 (Para producto disolventado)	144.990.500
HYDRAULIQUE, modèle R 440 (Pour produit hydro)	FLUID SECTION model R 440 (For hydro material)	#
HYDRAULIKTEIL Modell R 440 (Für Wasser Materialien)	HYDRAULIKTEIL Modell R 440 (Para producto hidro)	144.990.600

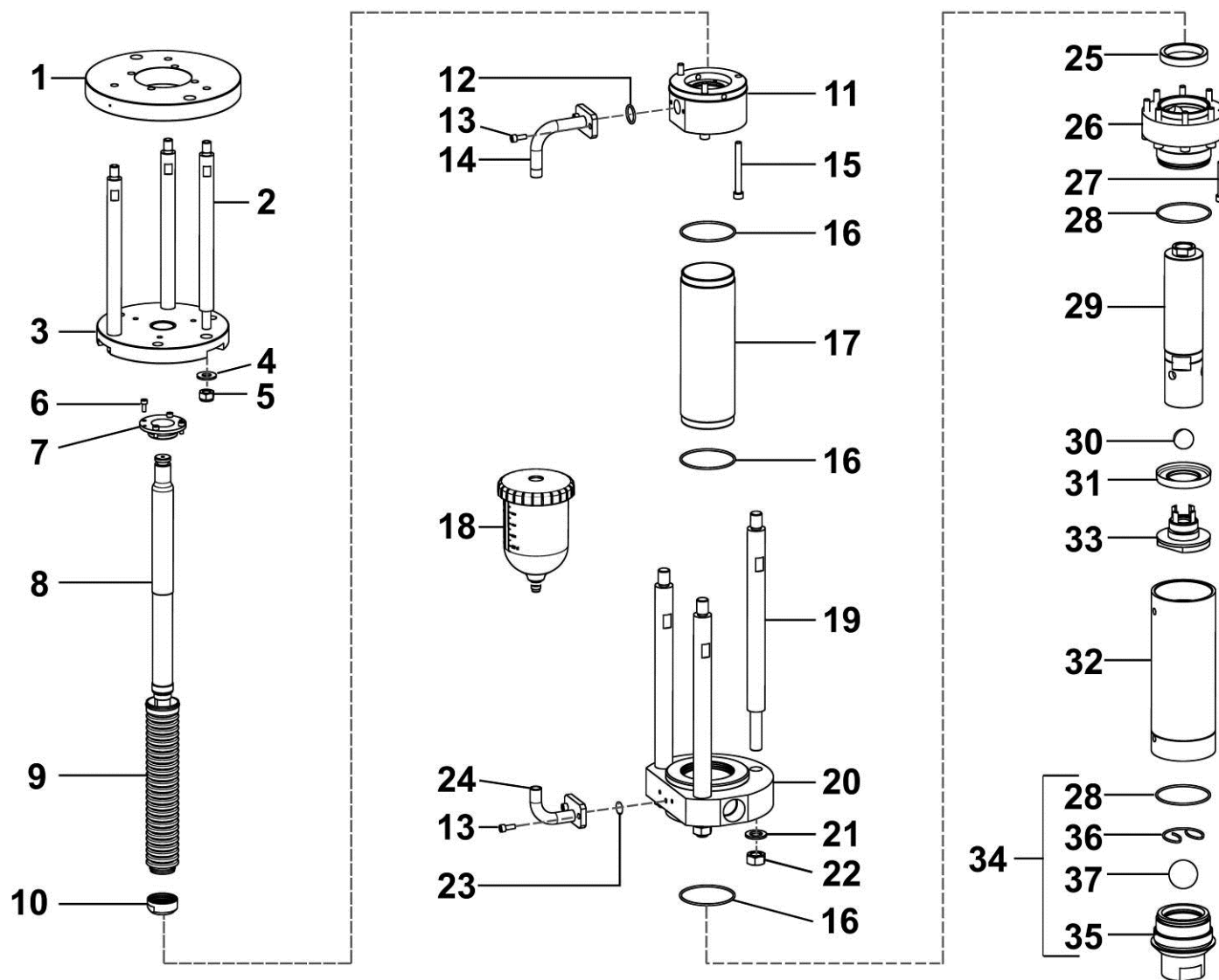



***Pièces communes - Common parts - Gleiche Teile - Partes comunes***

Ind	#	Désignation	Description	Bezeichnung	Denominación	Qté
1	144 990 504	Bride d'accouplement	Coupling flange	Pumpenflansch	Brida de acoplamiento	1
2	209 601	Tirant d'accouplement	Coupling rod	Kupplungsstange	Tirante de acoplamiento	3
3	144 990 505	Flasque	Flange	Flansch	Brida	1
4	963 040 023	Rondelle M 12	Washer, model M 12	Scheibe M 12	Arandela, tipo M 12	3
5	953 010 023	Ecrou M 12	Nut, model M 12	Mutter M 12	Tuerca, tipo M 12	3
6	931 151 168	Vis CHc M 5 x 12	Screw, model CHc M 5 x 12	Schraube M 5 x 12	Tornillo, tipo CHc M 5 x 12	4
7	044 970 046	Bride soufflet	Flange, bellows	Faltenbalg-Flansch	Brida fuelle	1
8	144 990 501	Tige d'accouplement	Coupling rod	Verbindungsstange	Eje de acoplamiento	1
*9	044 970 055	Soufflet	Bellows	Faltenbalg	Fuelle	1
10	044 990 211	Jupe	Skirt	Klemmstück	Faldón	1
11	044 990 013	Palier d'aspiration	Suction bearing	Oberer Flansch	Palier de aspiración	1
*12	150 040 321	Joint PTFE (les 10)	Seal, PTFE (pack of 10)	Dichtung PTFE (10 St.)	Junta PTFE (bolsa de 10)	1
13	88 512	Vis CHc M 6 x 16	Screw, model CHc M 6 x 16	Schraube M 6 x 16	Tornillo, tipo CHc M 6 x 16	4
14	144 990 502	Tube coudé	Elbow tube	Oberer Rohrbogen	Tubo acodado	1
15	933 151 671	Vis CHc M 8 x 75	Screw, model CHc M 8 x 75	Schraube M 8x75	Tornillo, tipo CHc M 8 x 75	3
*16	050 040 325	Joint PTFE	Seal, PTFE	Dichtung PTFE	Junta PTFE	3
*17	044 990 012	Cylindre	Cylinder	Materialzylinder	Cilindro	1
*18	144 990 530	Godet équipé (voir Doc. 573.465.050)	Cup assembly (refer to Doc. 573.465.050)	Kompletter Behälter (siehe Dok. 573.465.050)	Bote equipado (consultar Doc. 573.465.050)	1
19	044 990 016	Tirant d'accouplement	Coupling rod	Kupplungsstange	Tirante de acoplamiento	3
20	044 990 011	Bride d'aspiration	Suction flange	Unterer Flansch	Brida de aspiración	1
21	963 020 025	Rondelle Z 16	Washer, model Z 16	Scheibe Z 16	Arandela, tipo Z 16	3
22	953 010 025	Ecrou HM 16	Nut, model HM 16	Mutter M 16	Tuerca, tipo HM 16	3
*23	129 489 902	Joint PTFE (les 10)	Seal, PTFE (pack of 10)	Dichtung PTFE (10 St.)	Junta PTFE (bolsa de 10)	1
24	144 990 503	Tube coudé	Elbow tube	Unterer Rohrbogen	Tubo acodado	1
26	044 990 021	Bride de refoulement	Discharge flange	Druckflansch	Brida de expulsión	1
27	932 151 551	Vis CHc M 8 x 50	Screw, model CHc M 8 x 50	Schraube M 8 x 50	Tornillo, tipo CHc M 8 x 50	8
*28	050 040 326	Joint PTFE	Seal PTFE	Dichtung PTFE	Junta PTFE	2
*29	044 990 221	Piston	Piston	Kolben	Pistón	1
*30	907 414 269	Bille Ø 27, inox 440C	Ball Ø 27, stainless steel 440C	Kugel Ø 27, Edelstahl 440C	Bola Ø 27, inox 440C	1
*32	044 990 022	Cylindre	Cylinder	Materialzylinder	Cilindro	1
33	044 990 025	Clapet de refoulement	Exhaust valve	Druckventil	Válvula de expulsión	1

Ind	#	Désignation	Description	Bezeichnung	Denominación	Qté
*34	144 990 540	Clapet d'aspiration équipé (ind. 28, 35, 36, 37)	Suction valve assembly (ind. 28, 35, 36, 37)	Komplettes Ansaugventil (Pos. 28, 35, 36, 37)	Válvula de aspiración equipada (ind. 28, 35, 36, 37)	1
*28	050 040 326	▪ Joint PTFE	▪ Seal PTFE	▪ Dichtung PTFE	▪ Junta PTFE	1
*35	144 990 550	▪ Corps de clapet avec siège carbure	▪ Suction valve body with carbide seat	▪ Ansaugventilkörper mit Hartmetall-Sitz	▪ Cuerpo de válvula con asiento de carburo	1
36	044 990 032	▪ Jonc	▪ Stop ring	▪ Sicherungsring	▪ Anillo de retención bola	1
37	907 414 297	▪ Bille Ø 40, inox 440C	▪ Ball Ø 40, stainless steel 440C	▪ Kugel Ø 40, Edelstahl 440C	▪ Bola Ø 40, inox 440C	1

**Pièces spécifiques - Specific parts - Spezifische Teile - Partes específicas**

***pour produit solvanté / for solvent material / für Lösemittel Materialien / para producto solventado***

Ind	#	Désignation	Description	Bezeichnung	Denominación	Qté
*25	909 150 223	Joint GT	GT seal	GT Dichtung	Junta GT	1
*31	044 990 024	Joint coupelle (PEHD)	Cup seal (UHMW)	Kolbenmanschette (PEHD)	Junta copa (PEHD)	1

Ind	#	Désignation	Description	Bezeichnung	Denominación	Qté
*	144 990 090	Pochette de joints (ind. 12, 16x3, 23, 25, 28x2, 30, 31, 36, 37)	Package of seals (ind. 12, 16x3, 23, 25, 28x2, 30, 31, 36, 37)	Dichtungssatz (Pos. 12, 16 (3x), 23, 25, 28 (2x), 30, 31, 36, 37)	Bolsa de juntas (ind. 12, 16x3, 23, 25, 28x2, 30, 31, 36, 37)	1
*	144 990 595	Pochette de maintenance (ind. 33, 34 + pochette de joints)	Servicing kit (ind. 33, 34 + package of seals)	Reparatursatz (beinhaltet Pos. 33, 34 + den Dichtungssatz)	Bolsa de mantenimiento (ind. 33, 34 + bolsa de juntas)	1

- \* Pièces de maintenance préconisées
- \* Preceding the index number denotes a suggested spare part.
- \* Bezeichnete Teile sind empfohlene Ersatzteile.
- \* Piezas de mantenimiento preventivas.

- N C : Non commercialisé.
- N S : Denotes parts are not serviceable.
- N S : Bezeichnete Teile gibt es nicht einzeln, sondern nur komplett.
- N S : no suministrado.

**Pièces spécifiques - Specific parts - Spezifische Teile - Partes específicas**

***pour produit hydro / for hydro material / für Wasser Materialien / para producto hidro***

Ind	#	Désignation	Description	Bezeichnung	Denominación	Qté
*-	144 990 120	Ensemble d'adaptation pour joints PU	Adaptation assembly for Polyurethane seals	Adaptiereinheit für PU-Dichtungen	Conjunto de adaptación para juntas de poliuretano	1
25	NC / NS	▪ Joint PU	▪ Polyurethane seal	▪ PU-Dichtung	▪ Junta Poliuretano	1
60	NC / NS	▪ Joint de piston (PU)	▪ Seal, piston (Polyurethane)	▪ Kolbenmanschette (PU)	▪ Junta de pistón (Poliuretano)	1
61	NC / NS	▪ Porte-joint	▪ Seal holder	▪ Dichtungshalterung	▪ Porta junta	1
62	NC / NS	▪ Joint PTFE	▪ Seal PTFE	▪ Dichtung PTFE	▪ Junta PTFE	1
63	NC / NS	▪ Bague anti-extrusion	▪ Anti-extrusion ring	▪ Stützring Manschette	▪ Anillo anti-extrusión	1

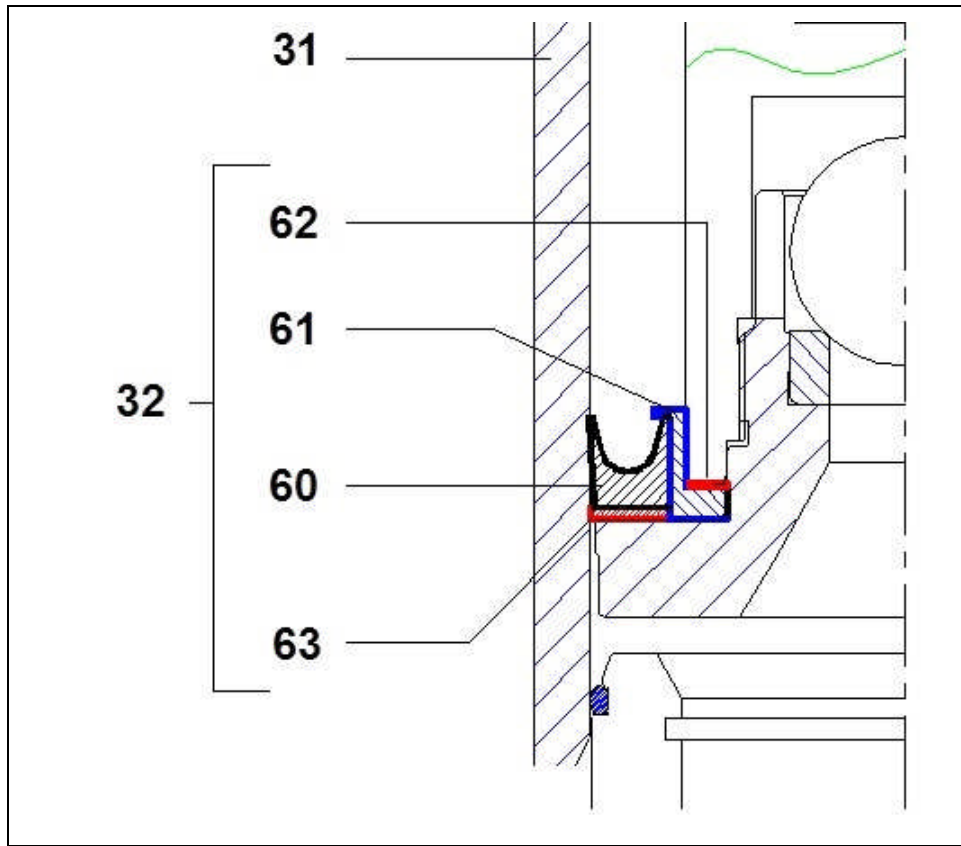

Ind	#	Désignation	Description	Bezeichnung	Denominación	Qté
*	144 990 130	Pochette de joints PU (ind. 12, 16x3, 23, 28x2, 25, 30, 35, 36, 60, 62, 63)	Package of seals (Polyurethane) (ind. 12, 16x3, 23, 28x2, 25, 30, 35, 36, 60, 62, 63)	PU-Dichtungssatz (Pos. 12, 16 (3x), 23, 28 (2x), 25, 30, 35, 36, 60, 62, 63)	Bolsa de juntas (Poliuretano) (ind. 12, 16x3, 23, 28x2, 25, 30, 35, 36, 60, 62, 63)	1
*	144 990 695	Pochette de maintenance (ind. 33, 34 + pochette de joints PU)	Servicing kit (ind. 33, 34 + package of seals (Polyurethane))	Reparatursatz (beinhaltet Pos. 33, 34 + PU-Dichtungssatz)	Bolsa de mantenimiento (índ. 33, 34 + bolsa de juntas (Poliuretano))	1

\* Pièces de maintenance préconisées  
 \* Preceding the index number denotes a suggested spare part.  
 \* Bezeichnete Teile sind empfohlene Ersatzteile.  
 \* Piezas de mantenimiento preventivas.

N C : Non commercialisé.  
 N S : Denotes parts are not serviceable.  
 N S : Bezeichnete Teile gibt es nicht einzeln, sondern nur komplett.  
 N S : no suministrado.

<b>Doc. 573.465.050</b> Date/Datum/Fecha : 02/03/15 Annule/Cancel/ Ersetzt/Anula :	<b>Modif. / Änderung :</b>	<b>Pièces de rechange</b> <b>Spare parts list</b> <b>Ersatzteilliste</b> <b>Piezas de repuesto</b>
---	----------------------------	---

<b>GODET EQUIPE (600 ml)</b>	<b>CUP ASSEMBLY (600 ml / 20.29 oz)</b>
<b>KOMPLETTER BEHÄLTER (600 ml)</b>	<b>BOTE EQUIPADO (600 ml)</b>



**A**

**A** : raccordement produit (M 1/4" G)

**A** : fluid fitting (M 1/4" G)

**A** : Material Anschluss (AG 1/4" G)

**A** : racor producto (M 1/4" G)

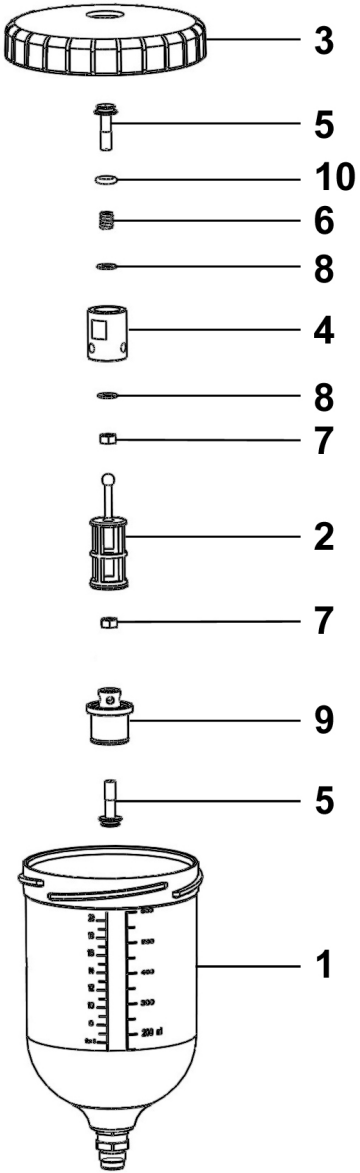

3

5

10

6

8

4

8

7

2

7

9

5

1

<b>GODET EQUIPE (600 ml)</b>	<b>CUP ASSEMBLY (600 ml / 20.29 oz)</b>	<b>#</b>
<b>KOMPLETTER BEHÄLTER (600 ml)</b>	<b>BOTE EQUIPADO (600 ml)</b>	<b>144.990.530</b>

Ind	#	Désignation	Description	Bezeichnung	Denominación	Qté
*1	NC / NS	Godet seul (600 ml)	Cup (600 ml / 20.29 oz)	Behälter(600 ml)	Bote solo (600 ml)	1
*2	139 270 220	▪ Tamis (les 5)	▪ Screen (pack of 5)	▪ Sieb (5er Satz)	▪ Tamiz (bolsa de 5)	1
3	NC / NS	Couvercle	Lid	Deckel	Tapa	1
4	NC / NS	Corps de clapet	Valve body	Ventilkörper	Cuerpo de válvula	1
5	NC / NS	Soupape	Valve	Ventil	Válvula	2
6	NC / NS	Ressort	Spring	Feder	Muelle	1
7	NC / NS	Ecrou M 5	Nut, model M 5	Mutter M 5	Tuerca, tipo M 5	2
8	NC / NS	Rondelle MU 5	Washer, model MU 5	Scheibe MU 5	Arandela,tipo MU 5	2
9	NC / NS	Butée de godet	End cup	Endanschlag Behälter	Tope de bote	1
*10	129 479 910	Joint (les 10)	Seal (pack of 10)	Dichtung (10 St.)	Junta (bolsa de 10)	1

\* Pièces de maintenance préconisées

\* Preceding the index number denotes a suggested spare part.

\* Bezeichnete Teile sind empfohlene Ersatzteile.

\* Piezas de mantenimiento preventivas.

N C : Non commercialisé.

N S : Denotes parts are not serviceable.

N S : Bezeichnete Teile gibt es nicht einzeln, sondern nur komplett.

N S : no suministrado.

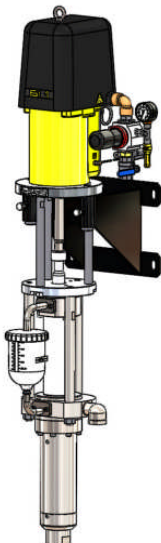

# **BALL PUMPS**

## ***EOS MODEL "R"***

### ***PREVENTIVE MAINTENANCE***

#### **TRANSLATION FROM THE ORIGINAL MANUAL**

***IMPORTANT : Before assembly and start-up, please read and clearly understand all the documents relating to this equipment (professional use only).***

THE PICTURES AND DRAWINGS ARE NON CONTRACTUAL. WE RESERVE THE RIGHT TO MAKE CHANGES WITHOUT PRIOR NOTICE.

#### **KREMLIN - REXSON**

150, avenue de Stalingrad

93 245 - STAINS CEDEX - France

**☎** : 33 (0)1 49 40 25 25      **Fax** : 33 (0)1 48 26 07 16

**[www.kremlin-rexson.com](http://www.kremlin-rexson.com)**

OPERATION TO CARRY OUT	FREQUENCY					
	D	W	M	Q	H	Y
<b>GENERAL</b>						
Check earthings	X					
Check leakage from the fittings		X				
Check hoses			X			
Operate the valves			X			
<b>PUMP</b>						
Check piston rod tightness		X				
<b>Caution : flush the pump for a long duration shutdown of the installation (more than two weeks)</b>						
<b>MOTOR</b>						
Check the tightness of the piston rod					X	
Check if the control system is clean			X			
Check if the muffler(s) is clogged						X
Check that there is no air leakage						X
Check that air hoses are not damaged						X
Check that the connections between fittings and hoses are correct						X
Check the correct condition of the supply hoses (rubber, setting,...), regulators and gauges						X
Check the tightening of the components						X
Check the fixing of the cover						X
Check the correct operating of the safety valve(s)						X
D : daily W : weekly M : monthly Q : quarterly H : half-yearly Y : yearly						

OPERATION TO CARRY OUT	FREQUENCY					
	D	W	M	Q	H	Y
<b>CUP - FLUID SECTION</b>						
Check that the filter is not damaged		X				
Check that the valves and the seal are not damaged			X			
Disassemble the fluid section, clean the parts with the appropriate cleaning solvent, change the seals and the parts if necessary						X
Drain the lubricant if the coloration is too important			X			
Clean regularly the cup			X			
Check the presence of lubricant in the cup		X				
D : daily W : weekly M : monthly Q : quarterly H : half-yearly Y : yearly						

**Note : Frequencies are given as a clue. They must be adapted by the maintenance service of the user for every installation according to the product, the working cadence and the working pressure.**



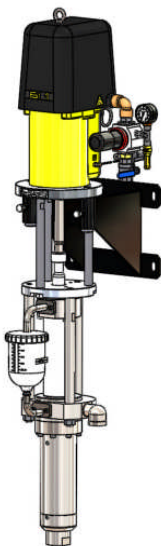

**BALL PUMPS**

***EOS MODEL "R"***

**TROUBLESHOOTING GUIDE**

**TRANSLATION FROM THE ORIGINAL MANUAL**

***IMPORTANT : Before assembly and start-up, please read and clearly understand all the documents relating to the equipment (professional use only).***

THE PICTURES AND DRAWINGS ARE NOT CONTRACTUAL. WE RESERVE THE RIGHT TO MAKE CHANGES WITHOUT PRIOR NOTICE.

**KREMLIN - REXSON**

150, avenue de Stalingrad

93 245 - STAINS CEDEX - France

**☎** : 33 (0)1 49 40 25 25      **Fax** : 33 (0)1 48 26 07 16

**[www.kremlin-rexson.com](http://www.kremlin-rexson.com)**

**The pump is manufactured under the ATEX agreement and can not be modified. KREMLIN REXSON will not be held responsible for any failure to comply with that instruction.**

**Guards (air motor cover, coupling shields, housings ...) have been designed for safe use of the equipment.  
The manufacturer will not be held responsible for bodily injury or failure and / or damage to property due to removal or partial removal of the guards**



**CAUTION :**

**Before any intervention on the equipment, shut off the air supply and follow the general safety instructions. Open the drain or the gun to depressurize the gun. The ram must be in the low position.**

TROUBLE	CAUSE	SOLUTION
Pump does not start or stops	The fluid is polymerized, hardened, dried in the pump.	Clean the pump; change parts if necessary.
	Broken part(s) in the pump	Remove, check and replace.
	Incorrect air supply	Check air pressure.
	Packings of fluid section are stuck	Clean or replace the packings.
	Frosting (motor)	Defrost and lubricate using oil.
	Outlet fluid hose is blocked	Change hose.
	Gun nozzle is clogged	Clean it.
The pump cycles continuously (drain valve closed)	No starting up	Check feeding pressure.
	Lack of material	Add material.
	Valves are blocked	Clean or replace.
The pump at stop, the piston carries on going down	Suction valve worn or incorrectly mounted	Check and replace parts.
	Plug or drain valve not tightened	
The pump at stop, the piston carries on going up	Head piston seals or upper valve worn or incorrectly mounted	Check and replace parts.
	Plug or drain valve not tightened	

TROUBLE	CAUSE	SOLUTION
The pump does not deliver enough pressure	Insufficient air pressure to the motor (valve insufficiently open, air leak,...)	Check; adjust.
	Insufficient air inlet on the motor or outlet clogged	Check filter and mounting.
	Hose not adapted	Replace hose.
	Head piston seals worn	Check mounting and replace seals.
The pump operates but irregular flow	Air inlet in the suction circuit	Check mounting, state of the parts, tightening of parts and seals.
	Valves not tightened or clogged on the seats	Clean.
	Worn valves	Check the valves and replace them.
	Valves incorrectly mounted	Check the valves and mount them.
	Leakage during the exhaust	Check the seals of the power distributor(s); change them if necessary.
	Muffler(s) clogged up	Clean or change.
Important pressure drop at down stroke	Too important getting up of the ball	Displace the ball cage to reduce the getting up.
Fluid leakage through pump body	Wrong tightening of the cylinder	Check cylinder and seals ; replace if necessary.
	Seals missing or damaged	
The piston is going down quickly (simple effect working)	Wrong feeding of the pump	Check the use parameters of the accessories (pressure on follower plate or suction rod,...) ; they can be clogged or not adapted.
	Suction valve worn	Check and replace parts.
	A foreign product obstructs the suction valve	Clean and check.
	Piston seals incorrectly mounted or damaged	Check the mounting; change if necessary.
The piston goes up quickly	Drain valve worn or damaged	Check and replace parts.
	A foreign product obstructs the drain valve	Clean and check.
	Piston seals incorrectly mounted or damaged	Check the mounting; change if necessary.

<b>TROUBLE</b>	<b>CAUSE</b>	<b>SOLUTION</b>
The piston goes down very quickly until it reaches half stroke and restarts operating slowly	Wrong draining of the pump	Open the drain valve and close it after the outlet of the air bubbles.
	Leakage at the suction valve	Check the suction valve; replace it if necessary.
Abnormal operating after racing or too important temperature	Head piston seals too tightened, damaged	Check mounting ; reduce pumping rate; replace parts if necessary.
	Product drum empty	Fill the drum; check the suction circuit and possible air leakage.
Material flow rate drop	Leakage during the exhaust	Check the piston seal(s); replace if necessary.
		Check the seals of the power distributor(s); replace them if necessary.
	Muffler(s) clogged up	Clean or change.
Important leakage during the exhaust	Power distributor(s) seals incorrectly mounted	Mount the seals correctly ; replace them if necessary.
	Defective Power distributor(s)	Check the operating; replace if necessary.
Motor piston(s) locked	Defective sensors	Adjust or replace the sensors.
	Defective control distributor	Check the operating; change if necessary.
	Defective power distributor(s)	Check the operating; change if necessary.
	Defective pneumatic circuit	Check the circuit.
The motor seems to operate but the fluid section does not deliver product	Defective coupling	Check coupling.
T lubricant leakage at the cylinder seals	Bad mounting of the PTFE seals	Check the mounting.
	Worn seals	Replace them.
T lubricant leakage at the elbow tube seals	Bad mounting of the PTFE seals	Check the mounting.
	Worn seals	Replace them.
Leakage of fluid at the bottom of the flange	Bellows damaged	Check the bellows; change if necessary.



# **BALL PUMP EOS MODEL R**

## **OPERATING AND START-UP**

### **TRANSLATION FROM THE ORIGINAL MANUAL**

**IMPORTANT : Before assembly and start-up, please read and clearly understand all the documents relating to this equipment (professional use only).**

THE PICTURES AND DRAWINGS ARE NON CONTRACTUAL. WE RESERVE THE RIGHT TO MAKE CHANGES WITHOUT PRIOR NOTICE.

#### **KREMLIN - REXSON**

150, avenue de Stalingrad

93 245 - STAINS CEDEX - France

**☎** : 33 (0)1 49 40 25 25      *Fax* : 33 (0)1 48 26 07 16

**[www.kremlin-rexson.com](http://www.kremlin-rexson.com)**

## 1. OPERATING PRINCIPLE

The pneumatic motors are designed to be coupled with the recommended KREMLIN-REXSON fluid section to get the required ratio and flow rate.

The pneumatic motors with rectilinear alternative motions operate thanks to the compressed air supply. The reversing system is carried out by means of :

- a distributor, model 4/2,
- two sensors,
- a distributor, model 5/2.



### **WARNING!**

The frictions due to the displacement of fluid inside the pumps and accessories, as well as the one created by the tightness seals, generate static electricity that may cause fire or explosion. This is why the pump must be grounded.

## 2. INSTALLATION

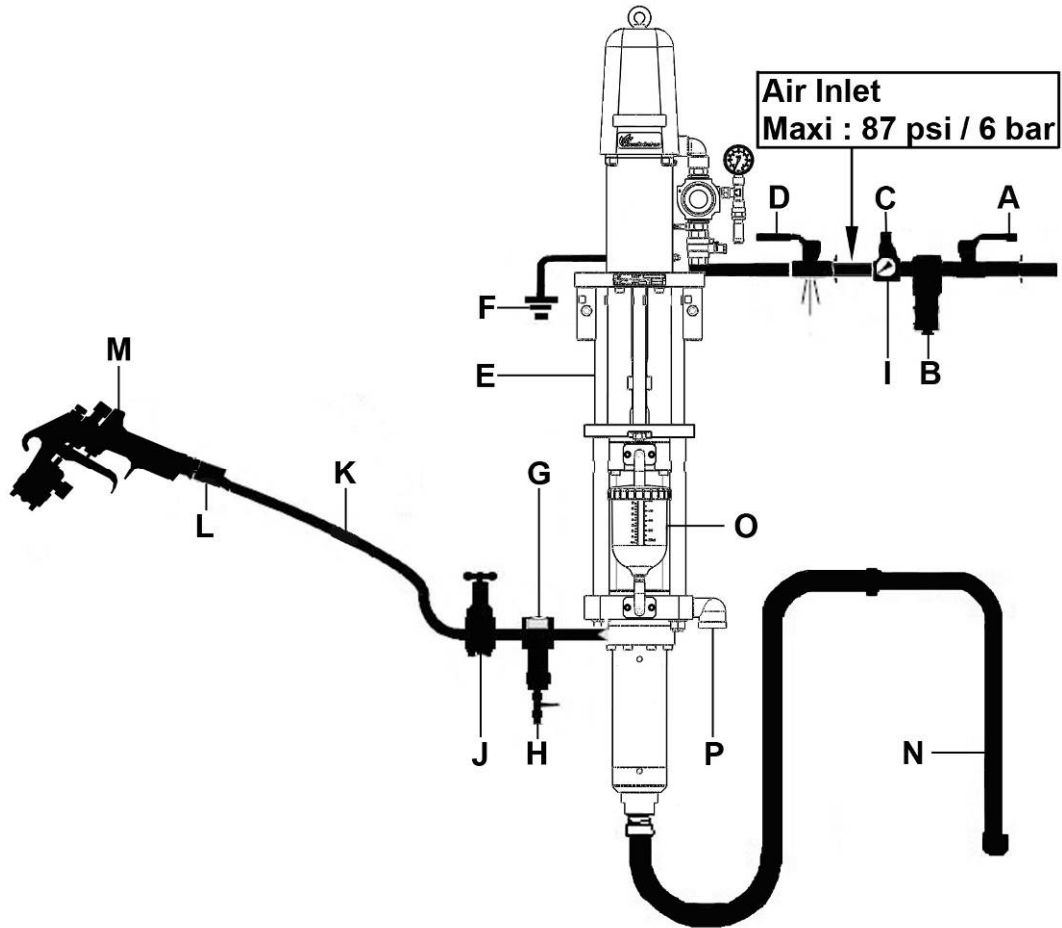

A	Air valve (main shut off valve)	I	Gauge
B	Filter or purifier	J	Fluid regulator
C	Air regulator	K	Hose with ground
D	Depressurize valve (air)	L	Swivel fitting
E	Pump	M	Spray gun
F	Grounding	N	Suction rod
G	Material filter	O	Cup
H	Fluid drain valve	P	Drain cup

(For other installation, please contact KREMLIN REXSON).

### 3. USE

- ADJUSTMENT

The increase of the motor supply air pressure (via the air regulator) leads to an increase of the number of pump piston returns/mn (cycles) which leads to a flow rate increase and to an outlet pressure increase of the pumped material.

AIR CONSUMPTION OF THE MOTOR	
Pressure of the motor at 6 bar / 87 psi	
Version	daN
1500	470
3000	920

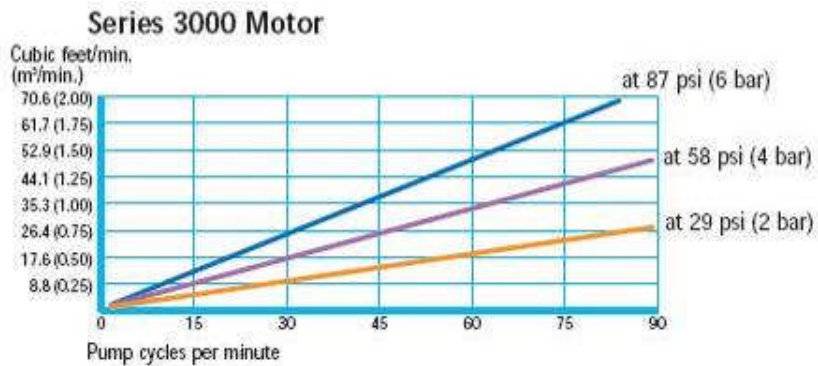
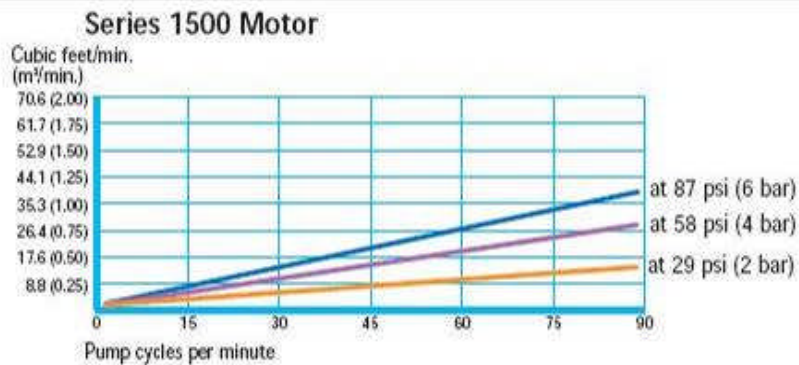



# 4. PNEUMATIC CABLING

Motor pneumatic diagram

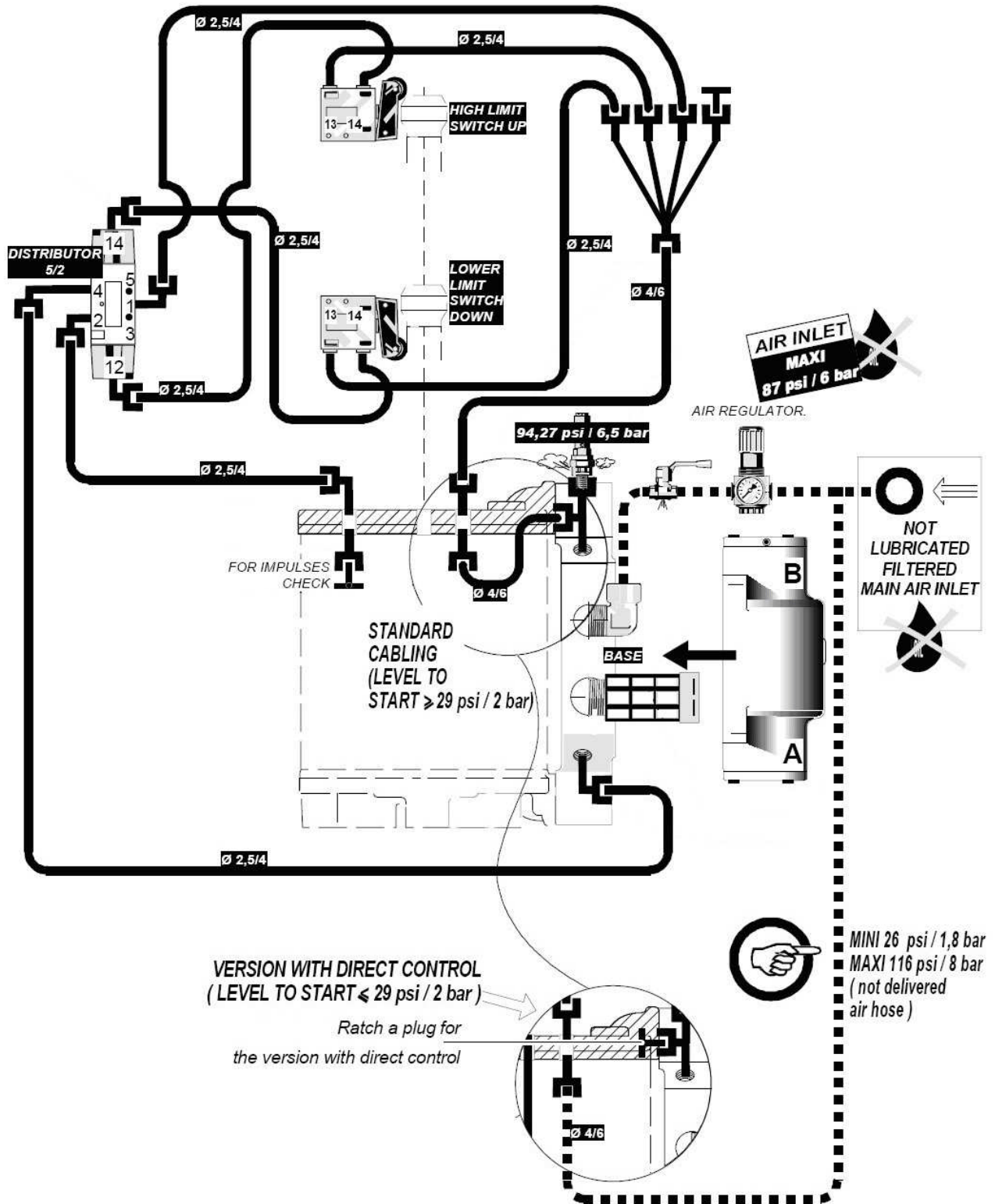

## 5. START UP

	<p>Protective clothing (gloves, protective masks, glasses, hearing protective earplug, protective clothing,...) should be worn to comply with the recommendations.</p> <p>The working area must be correctly ventilated.</p>
---	--

### ▪ BEFORE STARTING THE EQUIPMENT

**Guards (air motor cover, coupling shields, housings ...) have been designed for safe use of the equipment.**  
**The manufacturer will not be held responsible for bodily injury or failure and / or damage to property due to removal or partial removal of the guards**

### GROUNDING OF THE PUMP

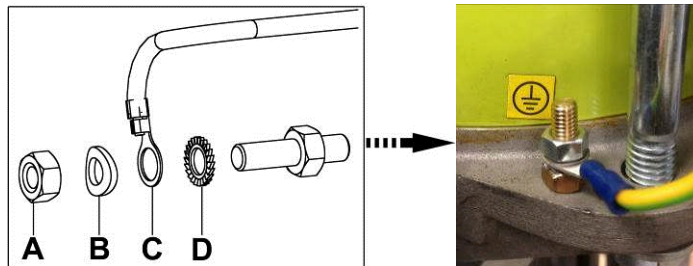

Unscrew the lock-nut (A), remove the washer (B), insert the lug (C) with its ground wire (D) (minimum section : 1,5 mm<sup>2</sup>) between the washer (B) and the washer (D). Tighten the lock-nut. Connect the other end of the wire to a real "ground", according to the national rules.

A qualified electrician must check the ground continuity. If the continuity is not correct, check the terminal, the electric wire, the U bolt and the ground point. Never operate pump without resolving the trouble.

### CONNECTION OF THE COMPRESSED AIR SUPPLY

For a correct operating and a long duration life of the motor, supply air must be filtered and not lubricated.

- You must install a **pressure relief valve** after the air regulator and near to the inlet motor to follow the pressure relief instructions.
- The motor air supply hose should have an internal diameter of at least 19 mm / 0.75".
- The motors are tested prior to their sending. Nonetheless, before coupling the motor to the pump, you must operate the no load motor during a few minutes to a maximum pressure of 1 bar / 14.5 psi.

Then, comply with the instructions as follows :

- Couple the motor to the required fluid section,
- Connect the main air supply to the motor,
- Adjust the pressure by means of the air regulator.

▪ **ADJUSTMENT**

**Guards (air motor cover, coupling shields, housings ...) have been designed for safe use of the equipment.**

**The manufacturer will not be held responsible for bodily injury or failure and / or damage to property due to removal or partial removal of the guards**

Before starting the equipment, (see the Installation section view).

Follow these instructions :

- The main air valve (A) is closed,
- Close the depressurize valve (D),
- Close the drain valve (H),
- Adjust the air regulator (C) on 'O',
- Adjust the fluid regulator (J) on 'O',
- Close the gun (M) (valve, gun,...),
- Open partially the drain valve (H), place a drum to get the drained material,
- Open the air valve (A),
- Open the depressurize air valve (D),
- Adjust the air regulator (C) to operate slowly the pump,
- Operate to get off air from the pump,
- Close the drain valve (H),
- Open the fluid regulator (J),
- Trigger the gun (M) (valve,...) and let it on the drum (grounded) to get off air from hoses, gun, valve,...
- Material must flow continuously (without air bubble),
- The pump must stop when the gun is closed (M) (valve, gun,...),
- Fill the T lubricant\* into the cup until it reaches the maximum level,
- Refill with the T lubricant\* until the backflow into the cup ( $\approx 1.2L / 0.32$  US gal).

**\* Use only KREMLIN REXSON T lubricant**

Then adjust :

- air pressure to the regulator (C),
- fluid pressure to the regulator (J).

Depending upon :

- material viscosity,
- gun nozzle diameter (M),
- material hoses' length and diameter (K),
- work.

**Nota : Before starting the work, check that the working range is correct.**

## ▪ START UP

**Guards (air motor cover, coupling shields, housings ...) have been designed for safe use of the equipment.  
The manufacturer will not be held responsible for bodily injury or failure and / or damage to property due to removal or partial removal of the guards**

The pumps are tested in our workshop with lubricant.  
Before starting up, you must flush the pump with the appropriate solvent.

## 6. SHUTDOWN AT THE END OF THE WORK

Unscrew the air regulator (s).  
Leave the pump full of material.  
When stopping the pump for a long time, after flushing it, leave it filled with solvent.  
Depressurize the system.

### ▪ SHORT SHUTDOWN

Flush the installation with the appropriate solvent to prevent from material drying inside the pump, hoses or accessories. Eliminate the pushed product by the solvent in a container and flow the solvent in a closed circuit until you get a sufficient flushing.

Remove the T lubricant\* from the cup (O) by the drain cup (Q) and refill with the T lubricant into the cup

**\*Use only KREMLIN REXSON T lubricant**

We advice you to stop the pump in 'low reversing' position to prevent from material drying on the piston rod.

- 1 - Decrease air pressure regulator (C) until you get 0 bar / 0 psi on the gauge (I),
- 2 - Trigger the gun to depressurize the system,
- 3 - Unscrew the gun air regulator or disconnect the gun air inlet,
- 4 - Remove the gun aircap and the nozzle (only when using an AIRMIX® gun) and soak them into solvent.

### ▪ LONG SHUTDOWN

After flushing the installation, to prevent from corrosion, fill the pump with oil solvent to prevent air bubbles and neutralize the residual material.



## **PUMP**

***EOS 06-R440***

***TECHNICAL FEATURES***

### **TRANSLATION FROM THE ORIGINAL MANUAL**

***IMPORTANT : Before assembly and start-up, please read and clearly understand all the documents relating to this equipment (professional use only).***

THE PICTURES AND DRAWINGS ARE NON CONTRACTUAL. WE RESERVE THE RIGHT TO MAKE CHANGES WITHOUT PRIOR NOTICE.

#### **KREMLIN - REXSON**

150, avenue de Stalingrad  
93 245 - STAINS CEDEX - France

**☎** : 33 (0)1 49 40 25 25      **Fax** : 33 (0)1 48 26 07 16

**[www.kremlin-rexson.com](http://www.kremlin-rexson.com)**

## 1. DESCRIPTION

- Air operated piston pump for high output
- Low maintenance and ease of use

### Recommandé pour :

- Water-based or solvent-based paints (low pressure)
- Circulating

## 2. TECHNICAL FEATURES

Motor type .....	3000-100	Air motor stroke	100 mm	4"
Body pump type .....	R440	Air motor section	154 cm <sup>2</sup>	23.9 sq.in
Theoretical pressure ratio .....	6/1	Fluid section	12 cm <sup>2</sup>	1.86 sq.in
<b>Weight :</b>		Delivery per cycle	440 cm <sup>3</sup>	15.5 oz
Wall mounted pump.....	55 kg / 121.25 lb	Number of cycle	2,3 per liter	8.6 per gallon
Bare pump.....	49 kg / 108 lb	Flow (20 cycles)	8,8 l	2.33 US gal
<b>Wetted parts :</b>		Maximum air operating pressure	6 bar	88 psi
Hard chrome stainless steel		Maximum discharge pressure	36 bar	523 psi
Stainless steel, carbide		Weighted sound pressure (LAeq)*	68,4 dBa	68,4 dBa
		Maximum operating temperature	50° C	122° F

### Tightness packings :

Bellows : polyethylene

Upper fixed : GT seal (polyethylene)  
or PU seal (red) on request

Lower, mobile : PEHD seal  
or PU seal (red) on request

### \*Test conditions :

- Test duration : 30 s,
- Motor air pressure : 6 bar / 87 psi,
- Material used : water,
- Nb of cycles/min : 20,

### ■ FITTINGS

		Pump assembly
Air	Inlet	F 3/4" BSP
Fluid	Inlet	F 1" NPS
	Outlet	F 3/4" NPS

### ■ HOSES WITH FITTINGS

Pump air supply hose (minimum  $\varnothing$  for a 5m / 16.5 ft length) :

$\varnothing$  20 mm / 3/4 " dia.

HP fluid hose (pump fluid outlet) :

minimum ID 9,52 mm / 3/8 " dia.

▪ **DIMENSIONS**

Ind.	mm	"	Ind.	mm	"	Ind.	mm	"
<b>A</b>	1333	<b>52.48</b>	<b>B</b>	265,5	<b>10.45</b>	<b>C</b>	326,5	<b>12.85</b>

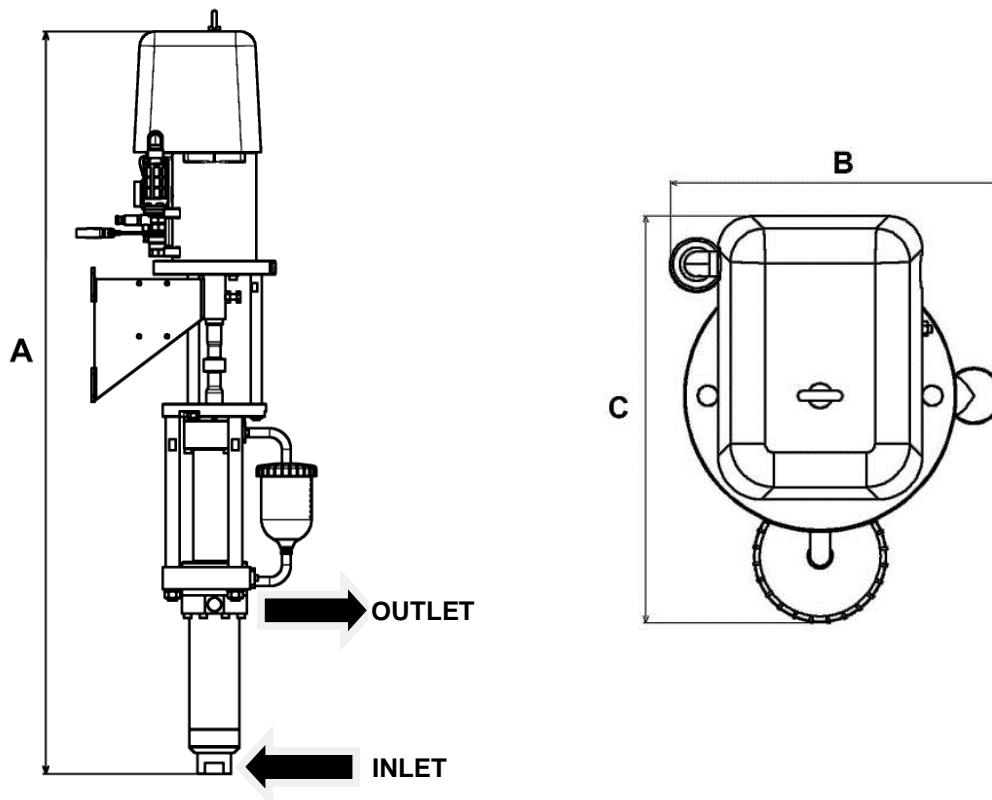

▪ **WALL MOUNTED BRACKET OF THE PUMP**

Ind.	mm	"	Ind.	mm	"	Ind.	mm	"	Ind..	mm	"
<b>D</b>	300	<b>11.81</b>	<b>E</b>	260	<b>10.23</b>	<b>F</b>	170	<b>6.7</b>	<b>G</b>	190	<b>7.48</b>
<b>H</b>	240	<b>9.45</b>	<b>I</b>	60	<b>2.36</b>	<b>J</b>	248	<b>9.76</b>			

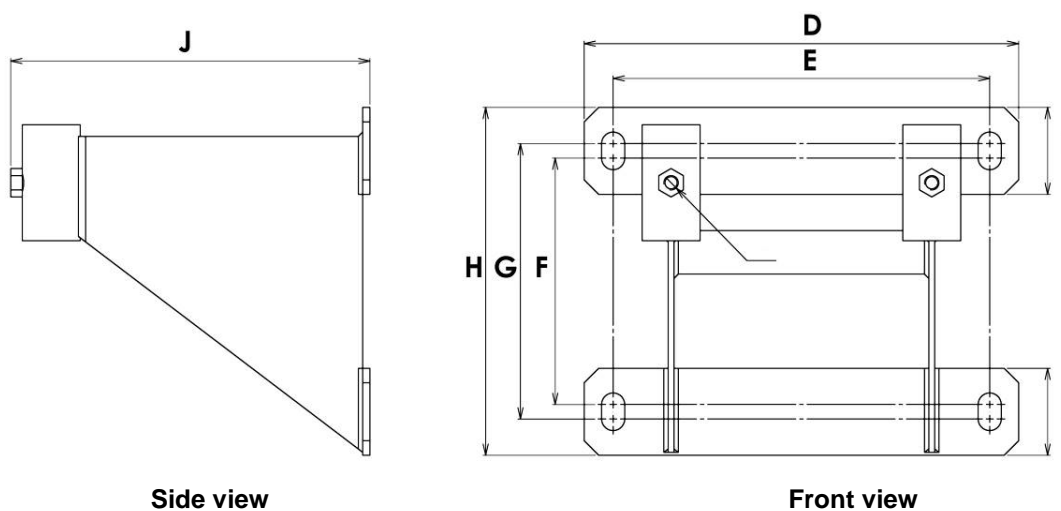

### 3. INSTALLATION

The pumps are designed to be installed in a spray booth.

#### ▪ DESCRIPTION OF THE LABEL MARKING

Marking according to the ATEX and Machines directives

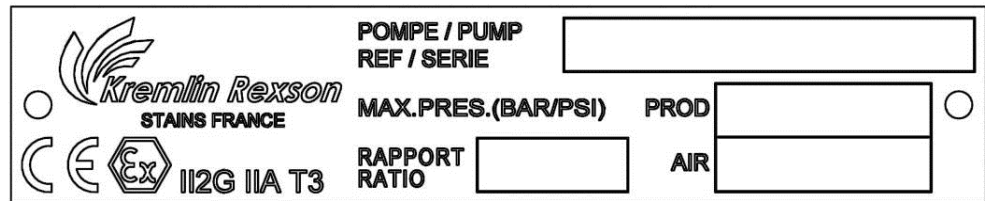

<b>KREMLIN REXSON</b>	Manufacturer brand
<b>CE</b>	European Conformity
<b>Ex II 2 G</b>	<b>II</b> : group II <b>2</b> : class 2 Surface equipment meant to an area in which there is an explosive atmosphere with an excessive mixture of air, gases and vapours, which can occasionally build up during normal operation. <b>G</b> : gas
<b>IIA T3</b>	<b>IIA</b> : Gas group for the equipment category <b>T3</b> : Maximum surface temperature : 200°C / 392°F
<b>POMPE / PUMP</b>	Pump version
<b>REF.</b>	Pump part number
<b>SERIE</b>	Number given by KREMLIN REXSON. The 2 first numbers indicate the manufacturing year.
<b>MAX. PRES. (BAR/PSI)</b>	
<b>PROD</b>	Maximum material pressure
<b>AIR</b>	Maximum air pressure
<b>RAPPORT / RATIO</b>	Pump pressure ratio



■ INSTALLATION INSTRUCTIONS

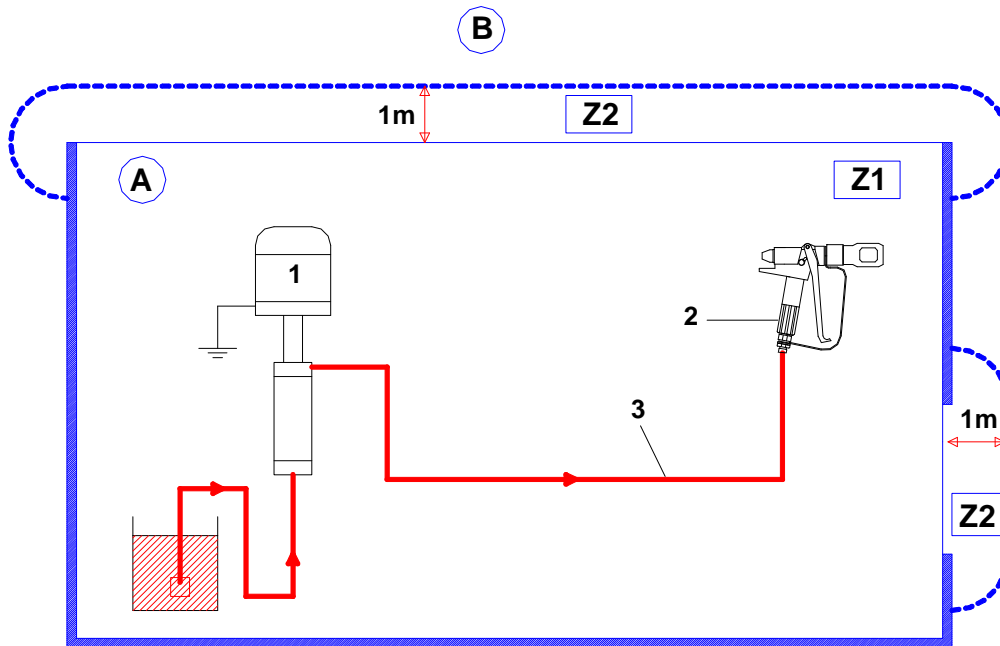

Ind.	Désignation
A	Explosive area area 1 (Z1) or area 2 (Z2) : spray booth
B	Non explosive area

Ind.	Désignation
1	Pump
2	Spray gun
3	Conductor high-pressure hose



The 1 m / 39.37" distance indicated in these diagrams is given for information purposes only and hold harmless to KREMLIN REXSON. The user is responsible for the extraction and conditioning of the painting area where the equipment is used, for working conditions conditions (refer to EN 60079-10 standard). The 1 m / 39.37" distance may be modified if trials carried out by the user deem this necessary.



*NB: Choose the appropriate pump to ensure that the working pressure supplied is suitable for the selected gun.*