



DOCUMENTATION - DOKUMENTATION - DOCUMENTACIÓN

PISTOLET / GUN / PISTOLE / PISTOLA

ATX

AIRMIX<sup>®</sup>

Notice / Manual / Betriebsanleitung : 582.059.110 - 1605

Date / Datum / Fecha : 27/05/16

Annule / Supersede / Ersetzt / Anula :

Modif. / Änderung :

**NOTICE ORIGINALE / TRANSLATION FROM THE ORIGINAL MANUAL**  
**/ ÜBERSETZUNG DER ORIGINAL BETRIEBSANLEITUNG**  
**/ TRADUCCIÓN DEL MANUAL ORIGINAL**

**IMPORTANT : Lire attentivement tous les documents avant le stockage, l'installation ou la mise en service du matériel concerné (à usage strictement professionnel).**

**Before assembly and start-up, please read and clearly understand all the documents relating to this equipment (professional use only).**

**WICHTIGER HINWEIS: Vor Lagerung, Installation oder Inbetriebnahme des Geräts bitte sämtliche Dokumente sorgfältig lesen (Einsatz nur von geschultem Personal).**

**IMPORTANTE : Lea con atención todos los documentos antes de almacenar, instalar o poner en marcha el equipo (uso exclusivamente profesional).**

PHOTOS ET ILLUSTRATIONS NON CONTRACTUELLES. MATÉRIELS SUJETS A MODIFICATION(S) SANS PREAVIS.

THE PICTURES AND DRAWINGS ARE NON CONTRACTUAL. WE RESERVE THE RIGHT TO MAKE CHANGES WITHOUT PRIOR NOTICE.

ALLE IN DIESEM DOKUMENT ENTHALTENEN SCHRIFTLICHEN ANGABEN UND ABBILDUNGEN STELLEN DIE NEUESTEN

PRODUKTINFORMATIONEN DAR. WIR BEHALTEN UNS DAS RECHT VOR, JEDERZEIT OHNE VORANKÜNDIGUNG ÄNDERUNGEN VORZUNEHMEN.

LAS FOTOGRAFÍAS E ILUSTRACIONES NO SON VINCULANTES. LOS MATERIALES ESTÁN SUJETOS A CAMBIOS SIN PREVIO AVISO.

**KREMLIN - REXSON**

150, avenue de Stalingrad

93 245 - STAINS CEDEX - France

**☎** : 33 (0)1 49 40 25 25      **Fax** : 33 (0)1 48 26 07 16

**[www.kremlin-rexson.com](http://www.kremlin-rexson.com)**



<p align="center"><b>FR</b></p> <p><b><u>Pour une utilisation sûre, il est de votre responsabilité de :</u></b></p> <ul style="list-style-type: none"> <li>• Lire attentivement tous les documents contenus dans le CD joint avant la mise en service de l'équipement,</li> <li>• D'installer, d'utiliser, d'entretenir et de réparer l'équipement conformément aux préconisations de KREMLIN REXSON ainsi qu'aux réglementations nationales et/ou locales,</li> <li>• Vous assurez que les utilisateurs de cet équipement ont été formés, ont parfaitement compris les règles de sécurité et qu'ils les appliquent.</li> </ul>	<p align="center"><b>UK</b></p> <p><b><u>To ensure safe use of the machinery, it is your responsibility to:</u></b></p> <ul style="list-style-type: none"> <li>• Carefully read all documents contained on the enclosed CD before putting the machinery into service,</li> <li>• Install, use, maintain and repair the machinery in accordance with KREMLIN REXSON's recommendations and national and/or local regulations,</li> <li>• Make sure that the users of the machinery have received proper training and that they have perfectly understood the safety rules and apply them.</li> </ul>	<p align="center"><b>DE</b></p> <p><b><u>Eine sichere Nutzung setzt voraus, dass Sie: :</u></b></p> <ul style="list-style-type: none"> <li>• alle in der CD enthaltenen Dokumente vor der Inbetriebnahme der Anlage aufmerksam lesen,</li> <li>• die Anlage im Einklang mit den Empfehlungen von KREMLIN REXSON sowie mit den nationalen und/oder lokalen Bestimmungen installieren, verwenden, warten und reparieren,</li> <li>• sich vergewissern, dass die Nutzer dieser Anlage angemessen geschult wurden, die Sicherheitsbestimmungen verstanden haben und sie anwenden.</li> </ul>
<p align="center"><b>ES</b></p> <p><b><u>Para una utilización segura, será de su responsabilidad:</u></b></p> <ul style="list-style-type: none"> <li>• leer atentamente todos los documentos que se incluyen en el CD adjunto antes de la puesta en servicio del equipo,</li> <li>• instalar, utilizar, efectuar el mantenimiento y reparar el equipo con arreglo a las recomendaciones de KREMLIN REXSON y a la normativa nacional y/o local,</li> <li>• cerciorarse de que los usuarios de este equipo han recibido la formación necesaria, han entendido perfectamente las normas de seguridad y las aplican.</li> </ul>	<p align="center"><b>IT</b></p> <p><b><u>Per un uso sicuro, vi invitiamo a:</u></b></p> <ul style="list-style-type: none"> <li>• leggere attentamente tutta la documentazione contenuta nel CD allegato prima della messa in funzione dell'apparecchio,</li> <li>• installare, utilizzare, mantenere e riparare l'apparecchio rispettando le raccomandazioni di KREMLIN REXSON, nonché le normative nazionali e/o locali,</li> <li>• accertarvi che gli utilizzatori dell'apparecchio abbiano ricevuto adeguata formazione, abbiano perfettamente compreso le regole di sicurezza e le applichino.</li> </ul>	<p align="center"><b>PT</b></p> <p><b><u>Para uma utilização segura, é da sua responsabilidade:</u></b></p> <ul style="list-style-type: none"> <li>• Ler atentamente todos os documentos incluídos no CD em anexo antes de pôr o equipamento em funcionamento,</li> <li>• Proceder à instalação, utilização, manutenção e reparação do equipamento de acordo com as preconizações de KREMLIN REXSON, bem como com outros regulamentos nacionais e/ou locais aplicáveis,</li> <li>• Assegurar-se que os utilizadores do equipamento foram devidamente capacitados, compreenderam perfeitamente e aplicam as devidas regras de segurança.</li> </ul>
<p align="center"><b>NL</b></p> <p><b><u>Voor een veilig gebruik dient u:</u></b></p> <ul style="list-style-type: none"> <li>• alle document op de bijgevoegde cd aandachtig te lezen alvorens het apparaat in werking te stellen,</li> <li>• het apparaat te installeren, gebruiken, onderhouden en repareren volgens de door KREMLIN REXSON gegeven aanbevelingen en overeenkomstig de nationale en/of plaatselijke reglementeringen,</li> <li>• zeker te stellen dat de gebruikers van dit apparaat zijn opgeleid, de veiligheidsregels perfect hebben begrepen en dat zij die ook toepassen.</li> </ul>	<p align="center"><b>SE</b></p> <p><b><u>För en säker användning av utrustningen ansvarar ni för följande:</u></b></p> <ul style="list-style-type: none"> <li>• Läs noga samtliga dokument som finns på den medföljande cd-skivan innan utrustningen tas i drift.</li> <li>• Installera, använd, underhåll och reparera utrustningen enligt anvisningarna från KREMLIN REXSON och enligt nationella och/eller lokala bestämmelser.</li> <li>• Försäkra er om att användare av denna utrustning erhållit utbildning, till fullo förstått säkerhetsföreskrifterna och tillämpar dem.</li> </ul>	<p align="center"><b>FI</b></p> <p><b><u>Käytön turvallisuuden varmistamiseksi velvollisuutesi on:</u></b></p> <ul style="list-style-type: none"> <li>• Lukea huolella kaikki CD:llä olevat asiakirjat ennen laitteiston käyttöönottoa,</li> <li>• Noudata laitteiston asennuksessa, käytössä, kunnossapidossa ja huollossa KREMLIN REXSON in suosituksia sekä kansallisia ja/tai paikallisia määräyksiä,</li> <li>• Varmistaa, että laitteiston käyttäjät ovat koulutettuja ja ymmärtävät täysin turvallisuusmääräykset ja miten niitä sovelletaan.</li> </ul>
<p align="center"><b>PL</b></p> <p><b><u>Dla zapewnienia bezpiecznego użytkowania na użytkownika spoczywa obowiązek:</u></b></p> <ul style="list-style-type: none"> <li>• Uważnego zapoznania się ze wszystkimi dokumentami znajdującymi się na załączonej płycie CD przed pierwszym uruchomieniem urządzenia,</li> <li>• Instalowania, użytkowania, konserwacji i naprawy urządzenia zgodnie z zaleceniami firmy KREMLIN REXSON oraz z przepisami miejscowymi,</li> <li>• Upewnienia, że wszyscy przeszkoleni użytkownicy urządzenia zrozumieli zasady bezpieczeństwa i stosują się do nich.</li> </ul>	<p align="center"><b>CS</b></p> <p><b><u>Pro bezpečné používání jste povinni:</u></b></p> <ul style="list-style-type: none"> <li>• Před uvedením zařízení do provozu si pozorně přečíst veškeré dokumenty obsažené na příloženém CD,</li> <li>• Nainstalovat, používat, udržívat a opravovat zařízení v souladu s pokyny firmy KREMLIN REXSON a s národními a/nebo místními legislativními předpisy,</li> <li>• Ujistit se, že uživatelé tohoto zařízení byli vyškoleni, že dokonale pochopili bezpečnostní pravidla a že je dodržují.</li> </ul>	<p align="center"><b>RU</b></p> <p><b><u>Для целей безопасного использования необходимо:</u></b></p> <ul style="list-style-type: none"> <li>• Ознакомиться со всеми документами, содержащимися в прилагаемом компакт-диске до ввода оборудования в эксплуатацию;</li> <li>• Устанавливать, использовать, производить техническое обслуживание и ремонт оборудования в соответствии с рекомендациями KREMLIN REXSON и национальным и/или местным законодательством;</li> <li>• Убедиться, что пользователи настоящего оборудования прошли подготовку, надлежащим образом усвоили правила безопасности и обеспечивают их соблюдение.</li> </ul>

Déclaration(s) de conformité au verso de ce document / Declaration(s) of conformity at the back of this document / Konformitätserklärung(en) auf der Rückseite dieser Unterlage / Declaración (es) de conformidad en el reverso de este documento / Dichiarazione/i di conformità sul retro del presente documento / Declaração(ões) de conformidade no verso do documento / Conformiteitsverklaring(en) op de keerzijde van dit document / Försäkran om överensstämmelse på omstående sida av detta dokument / Vaatimustenmukaisuusvakuutukset tämän asiakirjan kääntöpuolella / Deklaracja(e) zgodności na odwrocie dokumentu / Prohlášení o shodě se nachází/nacházejí na zadní straně tohoto dokumentu / Сертификат(ы) соответствия расположены на оборотной стороне настоящего документа

**VALABLE JUSQU'AU 19 AVRIL 2016**  
**VALID UNTIL 19 APRIL 2016**  
**GÜLTIG BIS ZUM 19. APRIL 2016**  
**VALIDEZ HASTA EL 19 DE ABRIL DE 2016**  
**VALIDO FINO AL 19 APRILE 2016**  
**APLICÁVEL ATÉ 19 DE ABRIL DE 2016**  
**GELDIG TOT 19 APRIL 2016**  
**GÄLLER TILL OCH MED DEN 19 APRIL 2016**  
**VOIMASSA 19.4.2016 SAAKKA**  
**WAŻNOŚĆ DO 19 KWIETNIA 2016 R.**  
**PLATÍ DO 19. DUBNA 2016**  
**ДЕЙСТВИТЕЛЬНО ДО 19 АПРЕЛЯ 2016 ГОДА**



**DECLARATION CE DE CONFORMITE**  
**EC DECLARATION OF CONFORMITY**  
**EG KONFORMITÄTSEKLRÄRUNG**  
**DECLARACIÓN CE DE CONFORMIDAD**  
**DICHIARAZIONE CE DI CONFORMITÀ**  
**DECLARAÇÃO CE DE CONFORMIDADE**  
**EG-VERKLARING VAN OVEREENSTEMMING**  
**EG-FÖRSÄKRAN OM ÖVERENSSTÄMMELSE**  
**EY-VAATIMUKSEN MUKAISUUSVAKUUTUS**  
**DEKLARACJA ZGODNOŚCI CE**  
**CE PROHLÁŠENÍ O SHODĚ**  
**ДЕКЛАРАЦИЯ СООТВЕТСТВИЯ CE**

Le fabricant / The manufacturer / Der Hersteller / El fabricante / Il produttore / O fabricante / De fabrikant / Tillverkare / Valmistaja / Producent / Výrobce / Изготовитель:	<b>KREMLIN REXSON</b> 150, avenue de Stalingrad 93 240 - STAINS - FRANCE Tél. 33 (0)1 49 40 25 25 - Fax : 33 (0)1 48 26 07 16
--	--

Déclare que le matériel désigné ci-après / Herewith declares that the equipment / erklårt hiermit, dass die / Declara que el material designado a continuación / Dichiaro che il materiale sottoindicato / Declara que o material a seguir designado / verklaart dat de hieronder aangeduide apparatuur / Kungör att den utrustning som anges här nedan / ilmoittaa, että alla mainitut laitteistot / Oświadcza, że wymienione poniżej urządzenia / Prohlašuje, že níže uvedené vybavení / Декларирует, что ниженазванное оборудование:

**PISTOLETS AUTOMATIQUES DE PULVERISATION AIRMIX® / AIRMIX® AUTOMATIC SPRAYING GUNS**  
**AIRMIX® AUTOMATIK SPRITZPISTOLEN / PISTOLAS AUTOMÁTICAS DE PULVERIZACIÓN AIRMIX®**

ATX
AVX
AXC

Est conforme à la législation d'harmonisation de l'Union applicable suivante / Is in conformity with the relevant Union harmonisation legislation / Erfüllt die einschlägigen Harmonisierungsrechtsvorschriften der Union / es conforme con la legislación de armonización pertinente de la Unión / è conforme alla pertinente normativa di armonizzazione dell'Unione / in overeenstemming met de desbetteffende harmonisatiewetgeving van de Unie / med den relevanta harmoniserade unionslagstiftningen / on asiaa koskevan unionin yhdenmukaistamislainsäädännön vaatimusten mukainen / jest zgodny z odpowiednimi wymaganiami unijnego prawodawstwa harmonizacyjnego / Shoduje se s následující příslušnou evropskou harmonizační legislativou / Соответствует следующим стандартизированным нормам Союза

Directive ATEX / ATEX Directive / ATEX Richtlinie / Directiva ATEX / Direttiva ATEX / Diretiva ATEX / ATEX-Richtijn / ATEX-direktivet / ATEX-direktivi / Dyrektywa ATEX / Směrnice ATEX / Директива ATEX	<b>94/9/CE</b>
--	----------------



Dominique LAGOUGE

Directeur Général / Chief Executive Officer / Generaldirektor  
 / Director General / Direttore Generale / Director Geral / Algemeen  
 Directeur / Generaldirektör / Pääjohtaja / Dyrektor Naczelny  
 / Dyrektor Generalny / Generální ředitel / Генеральный директор

Fait à Stains, le / Established in Stains, on / Geschehen zu Stains, am / En Stains, a / Redatto a Stains, / Vastgesteld te Stains, / Utformat i Stains, den / Stains, Ranska, / Sporządzono w Stains, dnia / Stains, dnia / Издано в г. Стен (Stains) 21/01/2010 - 01/21/2010

VALABLE A PARTIR DU 20 AVRIL 2016  
 VALID FROM 20 APRIL 2016  
 GÜLTIG AB DEM 20. APRIL 2016  
 VALIDEZ A PARTIR DEL 20 DE ABRIL DE 2016  
 VALIDO A PARTIRE DAL 20 APRILE 2016  
 APLICÁVEL A PARTIR DE 20 DE ABRIL DE 2016  
 GELDIG VANAF 20 APRIL 2016.  
 GÄLLER FRÅN OCH MED DEN 20 APRIL 2016  
 VOIMASSA 20.4.2016 ALKAEN  
 WAŻNOŚĆ OD 20 KWIETNIA 2016 R.  
 PLATÍ OD 20. DUBNA 2016  
 ДЕЙСТВИТЕЛЬНО С 20 АПРЕЛЯ 2016 ГОДА



**DECLARATION UE DE CONFORMITE**  
**UE DECLARATION OF CONFORMITY**  
**EU-KONFORMITÄTSEKTLÄRUNG**  
**DECLARACIÓN UE DE CONFORMIDAD**  
**DICHIARAZIONE DI CONFORMITÀ UE**  
**DECLARAÇÃO UE DE CONFORMIDADE**  
**EU-CONFORMITEITSVERKLARING**  
**EU-FÖRSÄKRAN OM ÖVERENSSTÄMMELSE**  
**EU-VAATIMUKSEN MUKAISUUSVAKUUTUS**  
**DEKLARACJA ZGODNOŚCI UE**  
**EU PROHLÁŠENÍ O SHODĚ**  
**ДЕКЛАРАЦИЯ О СООТВЕТСТВИИ НОРМАМ ЕС**

Le fabricant / The manufacturer / Der Hersteller / El fabricante / Il produttore / O fabricante / De fabrikant / Tillverkare / Valmistaja / Producent / Výrobce / Изготовитель:	<b>KREMLIN REXSON</b> 150, avenue de Stalingrad 93 240 - STAINS - FRANCE Tél. 33 (0)1 49 40 25 25 - Fax : 33 (0)1 48 26 07 16
--	--

Declare que le matériel désigné ci-après / Herewith declares that the equipment / erklärt hiermit, dass die / Declara que el material designado a continuación / Dichiaro che il materiale sottoindicato / Declara que o material a seguir designado / verklaart dat de hieronder aangeduide apparatuur / Kungör att den utrustning som anges här nedan / ilmoittaa, että alla mainitut laitteistot / Oświadcza, że wymienione poniżej urządzenia / Prohlašuje, že níže uvedené vybavení / Декларирует, что ниженазванное оборудование:

**PISTOLETS AUTOMATIQUES DE PULVERISATION AIRMIX® / AIRMIX® AUTOMATIC SPRAYING GUNS**  
**AIRMIX® AUTOMATIK SPRITZPISTOLEN / PISTOLAS AUTOMÁTICAS DE PULVERIZACIÓN AIRMIX®**

ATX
AVX
AXC

Est conforme à la législation d'harmonisation de l'Union applicable suivante / Is in conformity with the relevant Union harmonisation legislation / Erfüllt die einschlägigen Harmonisierungsrechtsvorschriften der Union / es conforme con la legislación de armonización pertinente de la Unión / è conforme alla pertinente normativa di armonizzazione dell'Unione / in overeenstemming met de desbetteffende harmonisatiewetgeving van de Unie / med den relevanta harmoniserade unionslagstiftningen / on asiaa koskevan unionin yhdenmukaistamislainsäädännön vaatimusten mukainen / jest zgodny z odpowiednimi wymaganiami unijnego prawodawstwa harmonizacyjnego / Shoduje se s následující příslušnou evropskou harmonizační legislativou / Соответствует следующим стандартизированным нормам Союза

Directive ATEX / ATEX Directive / ATEX Richtlinie / Directiva ATEX / Direttiva ATEX / Diretiva ATEX / ATEX-Richtlijn / ATEX-direktivet / ATEX-direktivi / Dyrektywa ATEX / Směrnice ATEX / Директива ATEX 	<b>2014/34/UE</b>
Procédure d'évaluation de la conformité : Module A Documentation technique (Annexe VIII) archivée par : / Conformity assessment procedure: Module A Technical documentation (ANNEX VIII) recorded by: / Verfahren zur Konformitätsbewertung: Modul A Technische Unterlagen (ANLAGE VIII) archiviert durch: / Procedimiento de evaluación de la conformidad: Módulo A Documentación técnica (ANEXO VIII) archivada por: / Procedura di valutazione della conformità: Modulo A Documentazione tecnica (ALLEGATO VIII) archiviata a cura di: / Procedimento de avaliação da conformidade: Módulo A Documentação técnica (ANEXO VIII) arquivada por: / Conformiteitsbeoordelingsprocedure: Module A Technische documentatie (BIJLAGE VIII) gearhiveerd door: / Förfarande för bedömning av överensstämmelse: Modul A Teknisk dokumentation (BILAGA VIII) arkiverad av: / Vaatimusten mukaisuusarviointimenetelmä: moduuli A Tekninen dokumentaatio (LIITE VIII) arkistoitu: / Procedura oceny zgodności: Moduł A Dokumentacji technicznej (ZAŁĄCZNIK VIII) zarchiwizowane przez: / Postup posuzování shody: Modul A Technická dokumentace (PŘÍLOHA VIII) archivována: / Процедура оценки соответствия: Модуль A Техническая документация (ПРИЛОЖЕНИЕ VIII), архивированная: ISSeP Zoning A. Schweitzer Rue de la Platinerie B - 7340 COLFONTAINE BELGIQUE	

Dominique LAGOUGE

Directeur Général / Chief Executive Officer / Generaldirektor / Director General / Direttore Generale / Director Geral / Algemeen Directeur / Generaldirektör / Pääjohtaja / Dyrektor Naczelny / Dyrektor Generalny / Generální ředitel / Генеральный директор

Fait à Stains, le / Established in Stains, on / Geschehen zu Stains, am / En Stains, a / Redatto a Stains, / Vastgesteld te Stains, / Utformat i Stains, den / Stains, Ranska, / Sporządzono w Stains, dnia / Stains, dnia / Издано в г. Стен (Stains) 04/04/2016 - 04/04/2016



# INSTALLATION AND SAFETY INSTRUCTIONS

## TRANSLATION OF THE ORIGINAL MANUAL

**IMPORTANT** : Before assembly and start-up, please read and clearly understand all the documents relating to this equipment (professional use only).

*THE PICTURES AND DRAWINGS ARE NON CONTRACTUAL. WE RESERVE THE RIGHT TO MAKE CHANGES WITHOUT PRIOR NOTICE.*

### **KREMLIN - REXSON**

150, avenue de Stalingrad

93 245 - STAINS CEDEX – France

☎ : 33 (0)1 49 40 25 25      Fax : 33 (0)1 48 26 07 16

**[www.kremlin-rexson.com](http://www.kremlin-rexson.com)**

# 1. SAFETY INSTRUCTIONS

## GENERAL SAFETY INSTRUCTIONS



**CAUTION** : The equipment can be dangerous if you do not follow our instructions concerning installation and servicing described in this manual and in accordance with applicable European standards and local national safety regulations.

Please carefully read all the instruction literature before operating your equipment.

**Only trained operators can use the equipment** (To acquire an essential training, please contact the "KREMLIN REXSON University" training center - Stains).

The foreman must ensure that the operator has understood the safety instructions for this equipment as well as the instructions in the manuals for the different parts and accessories.

Read carefully all instruction manuals, label markings before operating the equipment.



















Incorrect use may result in injury. This equipment is for professional use only. It must be used only for what it has been designed for. Never modify the equipment. The parts and accessories supplied must be regularly inspected. Defective or worn parts must be replaced.

**Guards (motor cover, coupling shields, connectors,...) have been designed for a safe use of the equipment.**  
**The manufacturer will not be held responsible for bodily injury or failure and / or property damage due to destruction, the overshadowing or the partial or total removal of the guards.**

**Never exceed the equipment components' maximum working pressure.**

Comply with regulations concerning safety, fire risks, electrical regulations in force in the country of final destination of the material. Use only products or solvent compatible with the parts in contact with the material (refer to data sheet of the material manufacturer).

## PICTOGRAMS

					
NIP HAZARD	WARNING MOVING ELEVATOR	WARNING MOVING PARTS	WARNING MOVING SHOVEL	DO NOT EXCEED THIS PRESSURE	HIGH PRESSURE HAZARD
					
RELIEF OR DRAIN VALVE	WARNING HOSE UNDER PRESSURE	WEAR GLASSES OBLIGATORY	WEAR OF GLOVES IS OBLIGATORY	PRODUCT VAPOR HAZARDS	WARNING HOT PARTS OR AREAS
					
ELECTRICAL HAZARD	WARNING FIRE HAZARDS	EXPLOSION HAZARDS	GROUNDING	WARNING (USER)	WARNING SERIOUS INJURIES

## FIRE - EXPLOSION - SPARKS - STATIC ELECTRICITY HAZARDS

A poor earth connection, inadequate ventilation, sparks or static electricity can cause an explosion or fire. to avoid these risks when using or servicing KREMLIN REXSON equipment, the following safety procedures must be followed :



- ensure a good earth connection and ground the parts to be handled i.e. solvents, materials, components and equipment,
- ensure adequate ventilation,
- keep working area clean and free from waste solvents, chemicals, or solid waste i.e. rags, paper and empty chemicals drums,
- never use electrical switches / power if in an atmosphere of volatile solvent vapour,
- stop working immediately in case of electrical arcs,
- never store chemicals and solvents in the working area.
- use paint whose flash point is the highest possible to prevent from any formation of gas and inflammable vapours (refer to materials' safety instructions),
- install a cover on the drums to reduce the diffusion of gas and vapours in the spraybooth.

## TOXIC PRODUCT HAZARDS

Toxic products or vapours can cause severe injury not only through contact with the body, but also if the products are ingested or inhaled. It is imperative :



- to know the material products and their risks,
- notified or hazardous materials must be stored in accordance with the regulations,
- the material must be stored in an appropriate container, never place materials in a container where there is a risk of spillage or leakage,
- a procedure must be applied for the safe disposal of waste material. It must comply with all prevailing regulations and legislations of the country where the equipment is to be used,
- protective clothing should always be worn in compliance with the material manufacturers' recommendations,
- depending on the application and chemical safety instructions, safety glasses, hearing protective earplug, gloves, foot wear, protective masks and possible breathing equipment should be worn to comply with the regulations (Refer to chapter "Safety equipment of KREMLIN selection guide).



### **CAUTION!**



It is forbidden to use material containing high concentrations of halogenated hydrocarbon solvents with **aluminium or zinc fillers** .Non-compliance with the instructions may cause explosion risk causing serious or fatal injury.

## **EQUIPMENT REQUIREMENTS**

**Guards (motor cover, coupling shields, connectors,...) have been designed for a safe use of the equipment.**

**The manufacturer will not be held responsible for bodily injury or failure and / or property damage due to destruction, the overshadowing or the partial or total removal of the guards.**

### **PUMP**



Before carrying out any work, it is imperative to read and clearly understand the disassembly and reassembly instructions before servicing. The operator must understand the equipment and the safety instructions. These instructions are available in the equipment manuals.



The air motor is designed to be mounted with a pump. Never modify any components or couplings. When operating, please keep hands away from moving parts. Before starting up the equipment, please read the PRESSURE RELIEF instructions. Please ensure that any relief or drain valves fitted are in good working order.

### **HOSES**

- Keep hoses out of circulation areas, moving parts or hot surfaces,
- Never expose product hoses to temperature higher than + 60°C / 140° F or lower than 0°C / 32° F,
- Never pull or use the hoses to move the equipment,
- Tighten all fittings as well as the hoses before operating the equipment,
- Check the hoses regularly; change them if they are damaged,
- Never exceed the working pressure (WP) indicated on the hose.

## **USED PRODUCTS**

Considering the wide variety of products that are available and can be used in our equipment it is impossible to check and make recommendations for all chemical data, regarding the risks of possible chemical attack and their long term chemical reaction

KREMLIN REXSON can not be held liable for :

- Compatibility of wetted parts,
- Risks to staff and the surroundings,
- for worn or defective parts, for faulty equipment or units, or the quality of final product.

It is the responsibility of the user to know and prevent any possible risks such as toxic vapours, fires or explosions. He shall determine the risks of immediate reactions or pursuant to repeated exposures of the staff,

KREMLIN REXSON shall not be liable for physical injuries, direct or indirect material damages caused by the use of chemicals.



## 2. HANDLING



### **Check the weight and the dimensions of the equipment**

**(☞ refer to 'Technical features' section of the instruction manual**

If weight and dimensions are too important, the unloading must be carried out by means of a forklift or any other appropriate means with a qualified personnel and in a clear horizontal area to prevent from risks of damage injury or an accident.

The centre of gravity is not in the centre of the machine : carry out by hand a stability-test after having lifted the whole at 10 cm / 3.937" maximum.

After the unloading, the handling of the whole (eg: elevator pump) is carried out by means of a pallet truck taking the bottom part of the frame.

**Remark : Each pump motor is fitted with a ring. The ring is designed for the hoisting of one pump and can not be used for the handling of the complete machine.**

## 3. STORING

Storing before installation :

- Storing ambient temperature : 0 / +50 °C / 0 / +122°F
- Protect the whole against dust, water trickling, dampness and shocks.

Storing after installation :

- Operating temperature : +15 / +35 °C / +59 / +138.2° F
- Protect the whole against dust, water trickling, dampness and shocks.

## 4. INSTALLATION OF THE EQUIPMENT

The machine is installed on a stable horizontal floor (for eg a concrete flag).



**To avoid risks caused by static electricity, the equipment as well as its components must be grounded.**

- **For the pumping equipments** (pumps, pneumatic rams, frame...), a section wire of 2.5 mm<sup>2</sup> is fixed on the material. Use this wire to connect the material to "the general ground". In case of severe environments (mechanical protection of the wire of earthing insufficient, vibrations, mobile material...) where function damages at the ground are probable, the user have to replace the provided wire of 2.5 mm<sup>2</sup> by a device more adapted to its environment (wire with a more important section, bonding strip, fixing by thimble with eyelet...),

The continuity of the ground must be controlled by a qualified electrician. If the continuity of the ground is not ensured, check the terminal, the wire and the earthing point. **Never** use the material without have solved this problem.

- In the severe cases of environments (mechanical protection of the wire of earthing insufficient, vibrations, mobile material...) where damages of the function put at the ground are probable, the user will have to replace the wire of 2.5 mm<sup>2</sup> provided, by a device more adapted to its environment (wire of more important section, bonding strip, fixing by thimble with eyelet...),
- **The gun** must be 'grounded' via a material hose or an air hose. In case of spraying by means of a gun with cup, the air hose must be conductive,
- **The materials to be painted** must also be grounded.

**All the materials situated in the working area shall be grounded.**



- **Never store** more than necessary inflammable materials inside the working area,
- The materials must be stored into **approved drums** and grounded,
- Use only grounded **metals containers** for the use of cleaning solvents,
- **Cardboard and paper are prohibited.**

## 5. MARKING OF THE EQUIPMENT

Each equipment has a marking plate.

The plate consists of the name of the manufacturer, the equipment part number and important information for correct use of the equipment (air pressure, electric power,...).

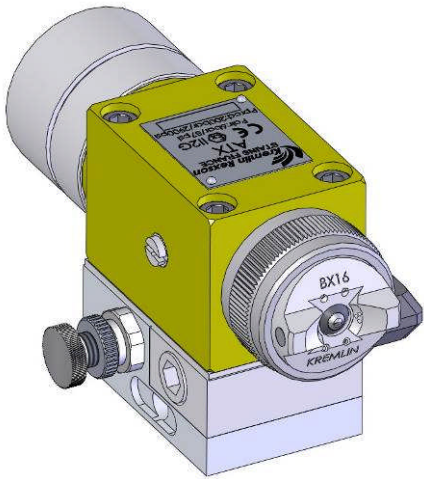

# **AUTOMATIC AIRMIX® GUN**

## **ATX**

***Disassembly / Reassembly***

### **TRANSLATION FROM THE ORIGINAL MANUAL**

***IMPORTANT : Before assembly and start-up, please read and clearly understand all the documents relating to this equipment (professional use only).***

THE PICTURES AND DRAWINGS ARE NON CONTRACTUAL. WE RESERVE THE RIGHT TO MAKE CHANGES WITHOUT PRIOR NOTICE.

#### **KREMLIN - REXSON**

150, avenue de Stalingrad

93 245 - STAINS CEDEX – France

☎ : 33 (0)1 49 40 25 25      Fax : 33 (0)1 48 26 07 16

**[www.kremlin-rexson.com](http://www.kremlin-rexson.com)**



**CAUTION :**

Before any intervention on the gun, shut off the compressed air supply and depressurize the circuits controlling the opening of the gun.

**The gun is manufactured under the ATEX agreement and can not be modified. KREMLIN REXSON will not be held responsible for any failure to comply with that instruction.**

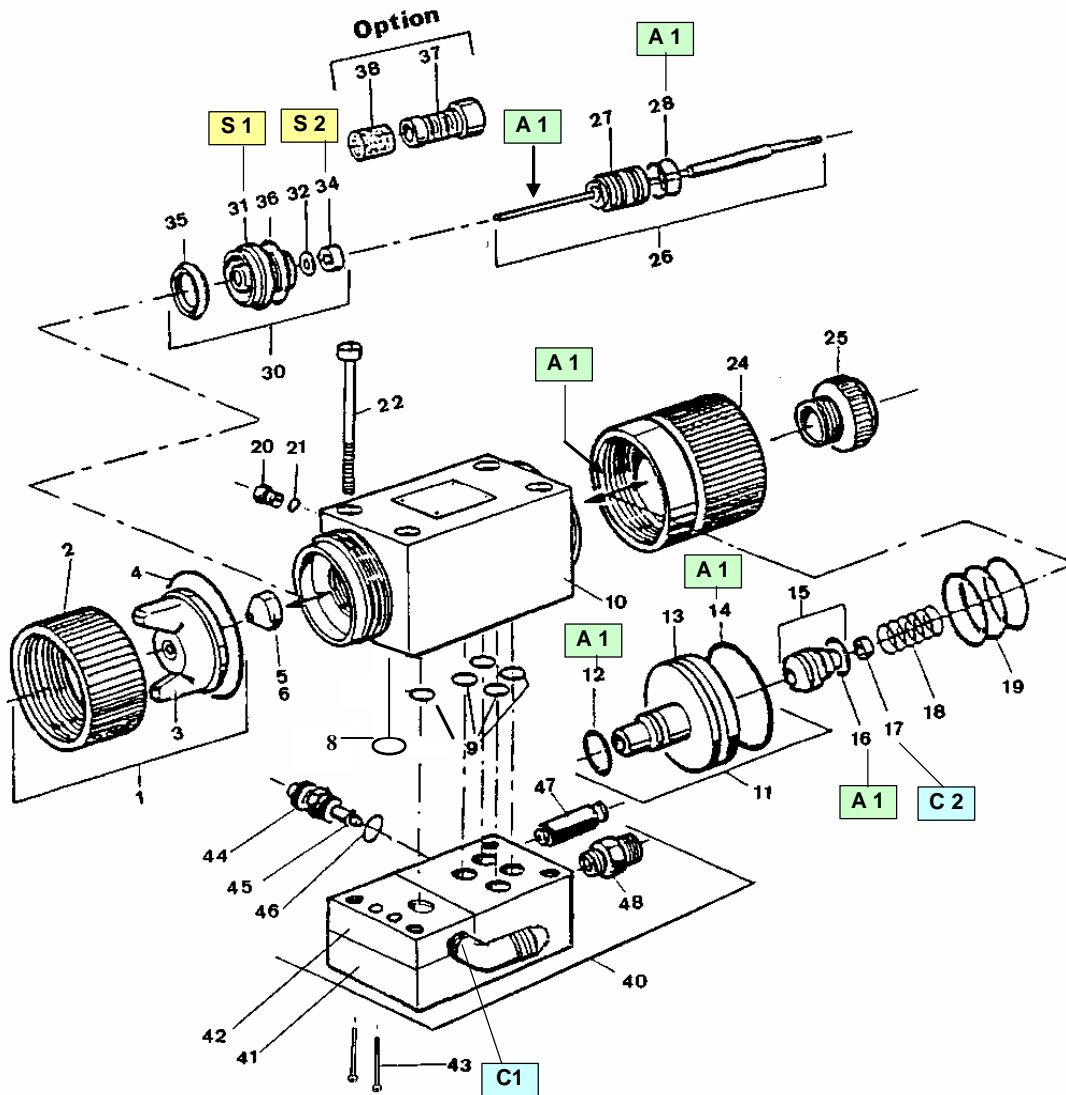

Index	Instructions	Description	Part number
<b>A 1</b>	PTFE grease	"TECHNILUB" grease (10 ml)	560.440.101
<b>C 1</b>	Medium strength Anaerobic Pipe sealant	Loctite 577	-
<b>C 2</b>	Low strength - Aneorobic Adhesive	Loctite 222	-
<b>S 1</b>	Screwing torque : 24 Nm / 17.7 ft/lbs		
<b>S 2</b>	Screwing torque : 2 Nm / 1.47 ft/lbs		

Before removing a component of the gun, some precautions have to be taken :

- Empty out the paint inside the cup or the receiver.
- Fill the cup or the receiver with cleaning solvent.
- Decrease the supply air pressure of the gun.
- Spray the solvent until it runs clear.
- Shut off the supply air pressure of the gun.
- Trigger the gun to depressurize the circuit.
- Empty out the solvent when using a gravity cup.
- Remove the part to be cleaned or changed.

**Before reassembling the different components, some precautions must be taken :**

- **Clean all the parts with the appropriate cleaning solvent and a brush.**
- **Install new seals if it is necessary after having lubricated them with PTFE grease.**
- **Install new parts if it is necessary.**

#### ▪ CHANGING THE SPRAY GUN

Shut off the air and fluid supplies of the gun.

Depressurize the circuits.

Remove the 4 screws (22) and disassemble the gun from its base.

Fit the new gun on the base and change the seals (8 and 9) and re-fit the 4 screws (22).

#### ▪ SEAT-HOLDER (30)

Remove air cap. With the wrench (50) supplied with the gun, unscrew seat-holder (31).

Clean inside of the gun. If required, replace seat-holder (refer to spare parts, ind. 30).

Unscrew the screw (34) with a screwdriver, remove the seat (32) and replace it.

Reinstall the seat as shown opposite (tightness cone towards the needle). Do not forget the seat seal (33) for stainless steel seat.

Reassemble in reverse order.

Nota : Before installing seal (35), soak it in a hot liquid (water or oil).

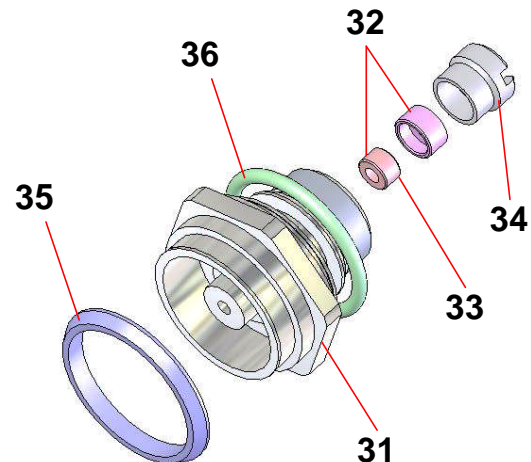

▪ **CARTRIDGE AND NEEDLE**

Unscrew the needle (24) - (be careful with springs 18 and 19).

Take driving-piston (15) and disengage it so that the rear part of the needle appears it from the rear side of the gun body.

Hold the rear side of the needle with a pliers and thanks to a spanner unscrew and remove nut (17).

Remove driving-piston (15).

Unscrew air cap (1), spray tip (5) as well as the seat-holder (30) from the gun.

Loosen fluid leakage detector (20) by two turns.

Firmly, push needle to extract it as well as cartridge-needle assembly (26) from the front side of the gun body.

Insert the cartridge and needle assembly into the front side of the gun.

➡ **IMPORTANT : thanks to a brass tube with a suitable diameter, firmly push cartridge to put it back properly inside the gun.**

Screw fluid leakage detector (20).

Place the piston (11) and the driving-piston (15) on the back part of the needle.

Screw and firmly install the nut (17). Reassemble the parts at the back part of the gun.

Screw the seat-holder (30), tighten it and respect recommended screwing torque.

Reinstall the nozzle (5) and the air cap (1).

**Before reassembling the different components :**

- Clean the parts with the appropriate cleaning solvent using a brush,
- Install the seals if necessary after having lubricated them with PTFE grease,
- Install new parts if necessary.

**Doc. 573.334.050**

Date/Datum/Fecha : 10/12/13

 Annule/Cancel/Ersetzt/Anula :  
 03/11/06

**Modif. / Änderung :**

Ind. 38 + p. 5

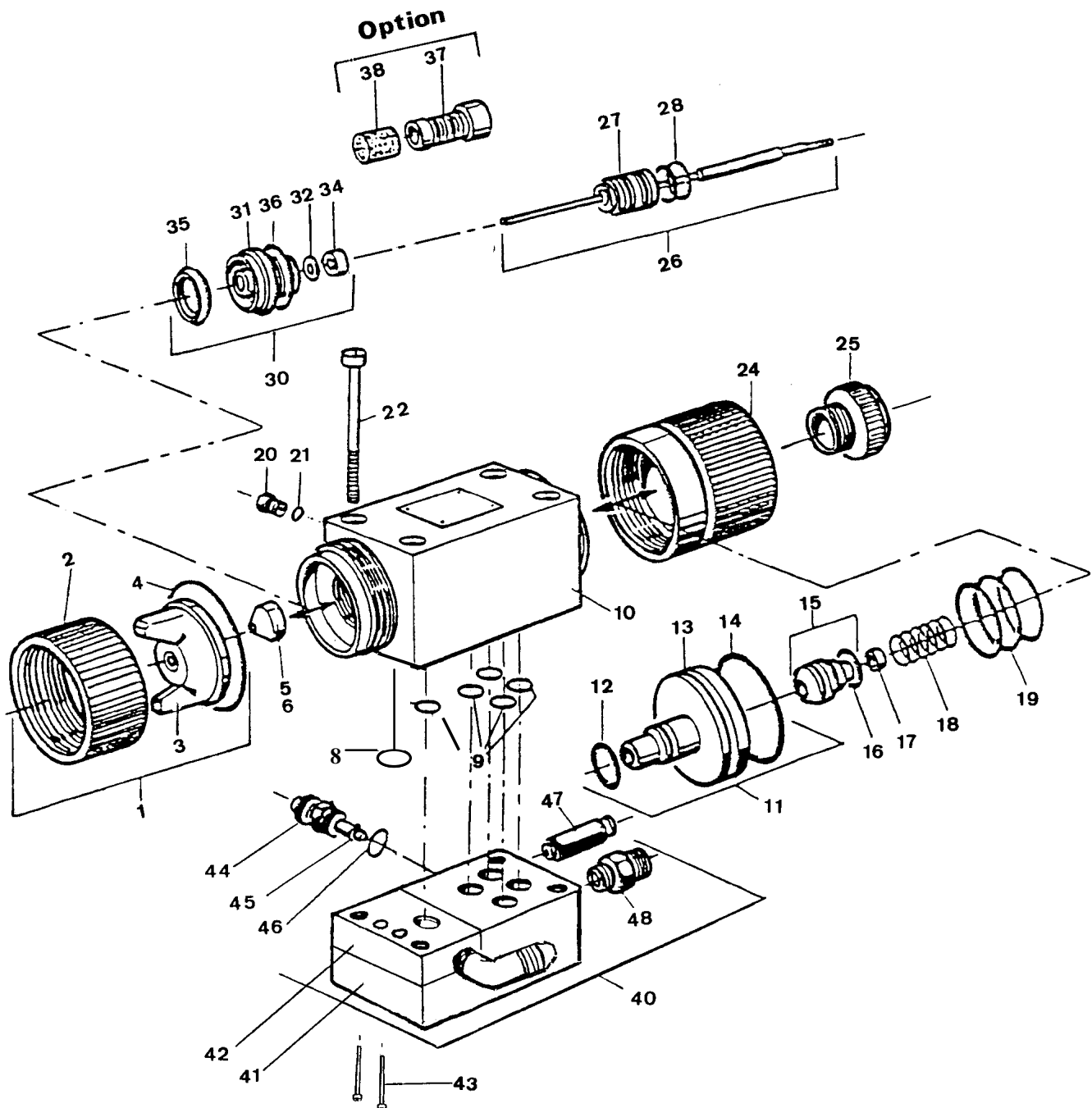
**Pièces de rechange**
**Spare parts list**
**Ersatzteilliste**
**Piezas de repuesto**
**ATX**
**PISTOLET AUTOMATIQUE AIRMIX® / AIRMIX® AUTOMATIC SPRAY GUN  
 AUTOMATIK AIRMIX® PISTOLE / PISTOLA AUTOMÁTICA AIRMIX®**
**Pression produit / Fluid pressure / Materialdruck / Presión producto : 200 bar / 2900 psi max.**

**ATX (inox / stainless steel / Edelstahl)**  
**Sans tête, ni buse / without aircap and tip / ohne Kopf und Düse / sin cabezal, ni boquilla**

<b>ATX STANDARD / ESTANDARD</b> (sans embase / without base / ohne Grundplatte / sin base)	<b># 129.625.000</b>
<b>EMBASE / BASE / GRUNDPLATTE</b>	<b># 129.260.360</b>

<b>ATX - spécial fûts / special drums/ speziell für Fässer / especial para bidones (avec embase / with base / mit Grundplatte / con base)</b>	<b># 129.626.500</b>
---	----------------------

<b>PISTOLET ATX STANDARD</b>	<b>ATX STANDARD GUN</b>	<b>#</b>  <b>129.625.000</b>
<b>PISTOLE ATX STANDARD</b>	<b>PISTOLA ATX ESTANDARD</b>	

Ind	#	Désignation	Description	Bezeichnung	Denominación	Qté
*1	-	<b>Tête complète</b> (voir accessoires)	<b>Aircap assembly</b> (refer to accessories)	<b>Zerstäuberkopf kpl.</b> (siehe Zubehör)	<b>Cabezal completo</b> (consultar accesorios)	1
2	032 020 001	• Bague de tête	• Aircap ring	• Überwurfring	• Anillo del cabezal	1
3	NC / NS	• Tête nue	• Aircap only	• Zerstäuberkopf	• Cabezal solo	1
4	150 040 309	• Joint de bague (les 10)	• Seal, ring (pack of 10)	• O-Ring (10 St.)	• Junta del anillo (x 10)	1
*5	-	<b>Buse à pion</b> (voir accessoires)	<b>Grooved Tip</b> (refer to accessories)	<b>Düse kpl. mit Kerbe</b> (siehe Zubehör)	<b>Boquilla con encaste</b> <b>tipo media luna</b> (consultar accesorios)	1
*6a	129 609 901	Micro-tamis (les 10) (voir accessoires)	Microfilter (pack of 10) (refer to accessories)	Mikrosieb (10 St.) (siehe Zubehör)	Micro-tamiz (x 10) (consultar accesorios)	1
*6b	129 529 903	Joint de buse (les 10) (voir accessoires)	Seal, tip (pack of 10) (refer to accessories)	Düsendichtung (10 St.) (siehe Zubehör)	Junta para boquilla (x 10) (consultar accesorios)	1
8	129 525 092	Joint (les 10)	Seal (pack of 10)	Dichtung (10 St.)	Junta (bolsa de 10)	1
9	129 251 991	Joint (les 10) → 4 trous circulaires + 1 trou oval	Seal (pack of 10) → 4 round holes + 1 elongated hole	Dichtung (10 St.) → 4 runde Löcher + 1 ovales Loch	Junta (bolsa de 10) → 4 agujeros circulares + 1 agujero oval	5
10	129 625 020	Corps pistolet en inox	Gun body, stainless steel	Pistolenkörper, Edelstahl	Cuerpo pistola inox	1
11	<b>129 251 200</b>	<b>Piston équipé</b>	<b>Piston assembly</b>	<b>Kolben, kpl.</b>	<b>Pistón equipado</b>	1
12	129 251 992	• Joint R8 (les 10)	• Seal, R8 (pack of 10)	Dichtung, R8 (10 St.)	• Junta R8 (bolsa de 10)	1
13	NC / NS	• Piston seul	• Piston only	Kolben, einzeln	• Pistón solo	1
14	129 251 993	• Joint R22 (les 10)	• Seal, R22 (les 10)	Dichtung, R22 (10 St.)	• Junta R22 (bolsa de 10)	1
15	<b>029 626 200</b>	<b>Entraîneur de pointeau</b>	<b>Retainer, needle</b>	<b>Nadelmitnehmer</b>	<b>Arrastre de la aguja</b> <b>equipado</b>	1
16	129 400 915	• Joint R5a (les 10)	• Seal, R5a (pack of 10)	• O-Ring, R5a (10 St.)	• Junta R5a (bolsa de 10)	1



Ind	#	Désignation	Description	Bezeichnung	Denominación	Qté
17	029 251 303	Ecrou spécial	Nut, special	Spezialmutter	Tuerca especial	1
*18	050 318 201	Ressort de pointeau	Spring, fluid needle	Farbnadelfeder	Muelle de aguja	1
19	050 313 504	Ressort de piston	Spring, piston	Kolbenfeder	Muelle de pistón	1
20	029 266 002	Témoin de fuite	Fluid leakage detector	Lekage-Anzeige	Testigo de fuga	1
21	129 529 903	Joint (les 10)	O-Ring (pack of 10)	O-Ring (10 St.)	Junta (bolsa de 10)	1
22	930 151 548	Vis CHc M 6 x 50	Screw, CHc M 6 x 50	Schraube M 6 x 50	Tornillo CHc M 6 x 50	4
24	029 251 401	Cylindre	Cylinder	Zylinder	Cilindro	1
25	029 625 301	Butée de ressort	Adjustment knob	Nadelanschlag	Tope de muelle	1
<b>*26</b>	<b>129 626 100</b>	<b>Cartouche assemblée</b>	<b>Cartridge assembly</b>	<b>Materialnadel kpl. mit Packung</b>	<b>Conjunto aguja cartucho</b>	<b>1</b>
27	NC / NS	• Cartouche - pointeau	• Cartridge with needle	• Packung	• Cartucho con aguja	1
28	129 529 906	• Joint en FPM (élastomères fluorés) (les 10)	• Seal, FPM (fluorous elastomers) (pack of 10)	• O-Ring, FPM (Elastomer aus Fluor) (10 St.)	• Junta FPM (elastómeros fluorados) (x 10)	2
<b>*30</b>	<b>129 626 400</b>	<b>Porte-siège assemblé</b>	<b>Seat-holder assembly</b>	<b>Düsennadelsitz, komplett</b>	<b>Porta-asiento montado</b>	<b>1</b>
31	029 620 501	• Porte-siège	• Seat-holder	• Düsennadelsitz	• Porta-asiento	1
*32	129 629 923	• Siège en inox avec joint (les 2)	• Seat with seal (stainless steel) (pack of 2)	• Nadelsitz-Einsatz in Edelstahl (2 St.)	• Asiento inox con junta (bolsa de 2)	1
33	129 629 922	- Joint de siège (les 10)	- Seal, seat (pack of 10)	- Dichtung (10 St.)	- Junta asiento (x 10)	1
34	029 600 106	• Vis	• Screw	• Schraube	• Tornillo	1
35	129 609 902	• Joint du porte-siège (les 10)	• Seal, seat-holder (pack of 10)	• Dichtung, Düsennadelsitz (10 St.)	• Junta porta-asiento (bolsa de 10)	1
36	129 629 914	• Joint torique (les 10)	• O-Ring (pack of 10)	• O-Ring (10 St.)	• Junta torica (x 10)	1
50	049 030 021	Clé plate KREMLIN	KREMLIN gun wrench	Pistolenschlüssel	Llave para pistola	1
51	906 300 101	Goupillon	Large size brush	Reinigungsbürste, groß	Cepillo grande	1

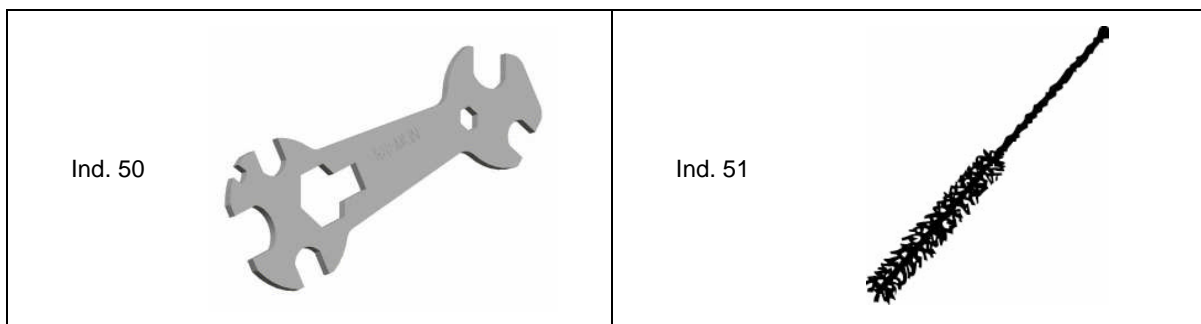

Ind	#	Désignation	Description	Bezeichnung	Denominación	Qté
*	<b>129 251 995</b>	<b>Pochette de joints (ind. 6, 8(x2), 9(x6), 12, 14, 16, 28(x2), 46)</b>	<b>Package of seals (ind. 6, 8(x2), 9(x6), 12, 14, 16, 28(x2), 46)</b>	<b>Dichtungssatz (Pos. 6, 8(2x), 9(6x), 12, 14, 16, 28(2x), 46)</b>	<b>Bolsa de juntas (ind. 6, 8(x2), 9(x6), 12, 14, 16, 28(x2), 46)</b>	<b>1</b>

\* Pièces de maintenance préconisées.

\* Preceding the index number denotes a suggested spare part.

\* Bezeichnete Teile sind empfohlene Ersatzteile.

\* Piezas de mantenimiento preventivas.

N C : Non commercialisé.

N S : Denotes parts are not serviceable.

N S : Bezeichnete Teile gibt es nicht einzeln, sondern nur komplett .

N S : no suministrado.

**ACCESSOIRES - ACCESSORIES - ZUBEHÖR - ACCESORIOS**

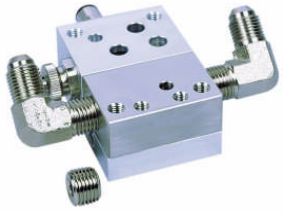
<b>EMBASE INOX avec raccords (ind. 40)</b>	<b>BARE (STAINLES STEEL) with fittings (ind. 40)</b>	<b>#</b>  <b>129.260.360</b>	
<b>GRUNDPLATTE (EDELSTAHL) mit Anschlüssen (Pos. 40)</b>	<b>BASE INOX con racores (ind. 40)</b>		

Ind	#	Désignation	Description	Bezeichnung	Denominación	Qté
-	129 260 315	Embase sans raccords	Base without fitting	Grundplatte ohne Nippel	Base sin racores	1
41	NC / NS	• Embase sans insert	• Base without insert	• Grundplatte ohne Einsatz	• Base sin inserto	1
42	NC / NS	• Insert inox	• Insert , stainless steel	• Einsatz, Edelstahl	• Inserto inox	1
43	933 151 221	• Vis CHc M 5x16	• Screw CHc M 5x16	• Schraube M 5x16	• Tornillo CHc M 5x16	2
*44	129 253 100	• Pointeau des événements	• Air adjuster	• Spritzstrahlregulierschraube	• Aguja control abanico	1
*45	129 971 002	- Joint (les 10)	- O-Ring (pack of 10)	- O-Ring (10 St.)	- Junta (bolsa de 10)	1
46	129 529 907	- Joint (les 10)	- O-Ring (pack of 10)	- O-Ring (10 St.)	- Junta (bolsa de 10)	1
47	905 124 901	Raccord (commande) M 1/8 BSP - T 4 x 6	Fitting, quick release (control) M 1/8 BSP- T 4x6	Steckanschluss für Schlauch 6 x 1 (Steuerluft)	Racor (mando) M 1/8 BSP - tubería 4 x 6	1
48	050 102 624	Raccord (air) M 1/4 BSP - M 1/4 NPS	Fitting (air) - double male 1/4 BSP - 1/4 NPS	Doppelnippel, AG 1/4 BSP - AG 1/4 NPS	Racor (aire) M 1/4 BSP - M 1/4 NPS	1
49	051 585 151	Raccord coudé inoxydable (produit) M 1/4 NPT - M 1/2 JIC	Elbow fitting, corrosion resistant (material) - double male 1/4 NPT - 1/2 JIC (# 5 JIC)	Winkelnippel, rostfrei (Material) AG 1/4 NPT - AG 1/2 JIC	Racor acodado inoxidable producto M 1/4 NPT - M 1/2 JIC	2
-	905 210 303	Bouchon inox 1/4 NPT	Plug, 1/4 NPT, stainless steel	Stopfen, 1/4 NPT, Edel- stahl	Tapón 1/4 NPT inox	1

**TETES - AIRCAP - ZERSTÄUBERKÖPFE - CABEZALES (ind. / Pos 1)**

	#	Utilisation	Use	Benutzung	Utilización
<b>BX 16</b>	132 620 026	Largeur de jet réglable et grande possibilité de réglage de débit	For adjustable pattern width - Adjustable flow rate	Einstellbare Spritzstrahlbreite, mit großer Variation der Ausbringmenge	Anchura de abanico regulable y grande posibilidad de regulacion de caudal
<b>BX 36</b>	132 650 200	Largeur de jet fixe	For permanent pattern width	Feste Spritzstrahlbreite	Anchura de abanico fija
<b>BX 56</b>	132 650 300	Largeur de jet fixe - Tête traitee anti-adhérent	For permanent pattern width - antiaderent treatment	Feste Spritzstrahlbreite - antihafbeschichteter Zerstäuberkopf	Anchura de abanico fija - Cabezal tratado anti- adherente
<b>BX 86</b>	132 650 100	Largeur de jet réglable	For adjustable pattern width	Einstellbare Spritzstrahlbreite	Anchura de abanico regulable
<b>BX 16 KHVLP</b>	132 650 450				
<b>BX 116 KHVLP</b>	132 650 550				

**TABLEAU DES BUSES - TIP CHART - DÜSENTABELLE - CUADRO DE BOQUILLAS (ind. / Pos. 5)**  
**(Buses en inox / Tips, stainless steel / Edeldstahldüsen / Boquillas de inox)**

**Buses standards / Standard tips / Standard Düsen / Boquillas estándar**

		Débit d'eau Water output Wasserdurchsatz Caudal agua (l / mn)				Repères tamis pour filtre Mesh number for filter Siebgröße für Filter Índices para filtro		Largeur de jet à 25 cm / Spray fan width at 25 cm (10") Strahlbreite bei 25 cm Abstand / Ancho abanico à 25 cm Avec tête / with aircap / mit Zerstäuberkopf / con cabezal												
								Maxi (cm)												
								9	12	17	21	25	29	33	37	44	56			
Calibre Size Grösse	Ø. mm	Pression / Pressure / Druck / Presión				Pistolet Gun Pistole Pistola	Pompe Pump Pumpe Bomba	Maxi (")												
		35 bar 500 psi	70 bar 1000 psi	120 bar 1740 psi	200 bar 2900 psi			3.5	4.7	6.7	8	10	12	13	14.5	17.3	22			
								Nombre gravé sur la buse / Number engraved on the tip Eingravierte Kennzahl auf der Düse / índice gravado sobre la boquilla												
02	0,15	0,07	0,10	0,13	0,17	4	2	02.034	02.054			02.114								
03	0,18	0,11	0,15	0,20	0,26	4	2	03.034	03.054	03.074			03.134							
04	0,23	0,16	0,22	0,29	0,38	4	2 ou 4	04.034	04.054	04.074	04.094	04.114	04.134							
06	0,28	0,23	0,33	0,43	0,57	4	4 ou 6	06.034	06.054	06.074	06.094	06.114	06.134	06.154						
07	0,30	0,28	0,39	0,51	0,66	6	4 ou 6								07.154					
09	0,33	0,32	0,45	0,59	0,77	6	6 ou 8	09.034	09.054	09.074	09.094	09.114	09.134	09.154	09.174					
12	0,38	0,42	0,60	0,79	1,03	6	8 ou 12			12.074	12.094	12.114	12.134	12.154	12.174					
14	0,41	0,51	0,72	0,94	1,23	12	8 ou 12		14.054	14.074	14.094	14.114	14.134	14.154	14.174					
18	0,48	0,67	0,95	1,24	1,63	12	12						18.134	18.154	18.174	18.194				
20	0,50	0,76	1,06	1,39	1,82	12	12			20.074	20.094	20.114	20.134	20.154	20.174	20.194				
25	0,56	0,94	1,33	1,74	2,28	12	15						25.134		25.174					
30	0,61	1,13	1,60	2,09	2,74	12	15						30.114	30.134	30.154	30.174	30.194			
40	0,72	1,54	2,18	2,85	3,73	12	20									40.174				
45	0,76	1,68	2,38	3,12	4,08	12	20						45.114		45.154	45.174	45.194			
100	1,04	3,96	5,68	7,33	9,47	12	20-30									100.174				100.214

**Buses spéciales pour peintures hydrodiluablees / Specific tips for water-based paints**  
**Spezielle Düsen für Wasserlacke / Boquillas específicas para pinturas hidrosolubles**

04	0,23	0,16	0,22	0,29	0,38	4	2 ou 4	04.032	04.052	04.072	04.092	04.112								
06	0,28	0,23	0,33	0,43	0,57	4	4 ou 6	06.032	06.052	06.072	06.092	06.112	06.132	06.152						
07	0,30	0,28	0,39	0,51	0,66	6	4 ou 6								07.152					
09	0,33	0,32	0,45	0,59	0,77	6	6 ou 8	09.032	09.052	09.072	09.092	09.112	09.132	09.152						
12	0,38	0,42	0,60	0,79	1,03	6	8 ou 12			12.072	12.092	12.112	12.132	12.152	12.172					
14	0,41	0,51	0,72	0,94	1,23	12	8 ou 12		14.052	14.072	14.092	14.112	14.132	14.152	14.172					

 Réglage de jet optimal / Optimum fan adjustment / Optimale Strahlregulierung / Ajuste de abanico óptimo



Pour établir la référence d'une buse, remplacer les croix par le nombre repère de la buse précédé de 134 5XX XXX  
 Exemple : pour commander une buse 09.094, utiliser la référence : 134 509 094

To obtain tip part number, replace the crosses by the engraved tip number preceded by 134 5XX XXX  
 Example : use part number 134 509 094 to obtain TIP N° 09.094

Die Bestell-Nr. erhält man, indem man die Kreuze durch die vorgenannte Kennzahl ersetzt : 134 5XX XXX  
 Beispiel : für eine Düse 09.094 ergibt sich die Bestell-Nr. : 134 509 094

Para establecer la referencia de una boquilla reemplazar las cruces por el número de la boquilla precedido por 134 5XX XXX  
 ejemplo : para pedir una boquilla 09.094 emplear la referencia : 134 509 094

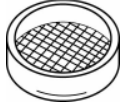
**JOINT ET MICRO-TAMIS DE BUSE - TIP MICROFILTER AND SEAL - DÜSENDICHTUNGEN UND MIKROSIEBE - JUNTA Y MICROTAMIZ DE BOQUILLA**

Ind		#	Désignation	Description	Bezeichnung	Denominación
6a		129 609 901	<b>Micro-tamis 100 µ</b> (les 10) - Seulement pour buses 03, 04 et 06	<b>Microfilter 100 µ</b> (pack of 10) - Only for tips size 03, 04 and 06	<b>Micro-Sieb 100 µ</b> (10 St.) - Nur für Düsentyp 03, 04 und 06	<b>Micro-tamiz 100 µ</b> (bolsa de 10) - Solo para boquillas 03, 04 y 06
6b		129 529 903	<b>Joint PTFE</b> (les 10) - Seulement pour buse de 09 et calibre supérieur	<b>PTFE seal</b> (pack of 10) - Only for tips size 09 and above	<b>PTFE-Düsendichtungen</b> (10 St.) - Nur für Düsentyp 09 und grösser	<b>Junta PTFE</b> (bolsa de 10) - Solo para boquilla de 09 y calibre superior

**OPTIONS - ON REQUEST - OPTIONEN - OPCIONES**

**FILTRE - GUN FILTER - SIEB FÜR PISTOLENFILTER - FILTRO**

Ind	#	Désignation	Description	Bezeichnung	Denominación
37	NC / NS	Support filtre	Filter support	Stützschraube	Soporte filtro
38	NC / NS	Tamis N° 2 (77 µ)	Screen N° 2 (77 µ)	Sieb Nr 2 (77 µ)	Tamiz N° 2 (77 µ)
38	NC / NS	Tamis N° 4 (99 µ)	Screen N° 4 (99 µ)	Sieb Nr 4 (99 µ)	Tamiz N° 4 (99 µ)
38	NC / NS	Tamis N° 6 (168 µ)	Screen N° 6 (168 µ)	Sieb Nr 6 (168 µ)	Tamiz N° 6 (168 µ)
38	NC / NS	Tamis N° 12 (280 µ)	Screen N° 12 (280 µ)	Sieb Nr 12 (280 µ)	Tamiz N° 12 (280 µ)
37 + 38		Support et tamis (les 2)	Support and screen (pack of 2)	Stützschraube und Sieb (2 St.)	Soporte y tamiz (bolsa de 2)
	129 629 906	N° 2 (77 µ)	N° 2 (77 µ)	Nr 2 (77 µ)	N° 2 (77 µ)
	129 629 905	N° 4 (99 µ)	N° 4 (99 µ)	Nr 4 (99 µ)	N° 4 (99 µ)
	129 629 907	N° 6 (168 µ)	N° 6 (168 µ)	Nr 6 (168 µ)	N° 6 (168 µ)
	129 629 916	N° 12 (280 µ)	N° 12 (280 µ)	Nr 12 (280 µ)	N° 12 (280 µ)

Ind	#	Désignation	Description	Bezeichnung	Denominación
26	129 626 180	Cartouche avec joint GT	Cartridge with GT seal	Packung mit GT Dichtung	Cartucho sin junta GT
28	109 420 257	Joint de cartouche en EPDM (les 10) pour produits : acétone, MEK	EPDM seal, cartridge (pack of 10) for fluid : cetone, MEK	O-Ring für Packung aus EPDM (10 St.) für Material : Acetone, MEK	Junta de cartucho de EPDM (bolsa de 10) para productos : acetona, MEK
32	129 609 911	Siège en résine acétale (les 10)	Seat, acetal resin (pack of 10)	Nadelsitz aus Acetalharz (10 St.)	Asiento en resina acetabo (x 10)
32	129 659 904	Siège en carbure avec joint (les 2)	Seat with seal, carbide (pack of 2)	Nadelsitz aus Hartmetall und Dichtring (2 St.)	Asiento carburo con junta (bolsa de 2)
49	905 210 602	Raccord coudé en inox (produit) M 1/4 BSP - M 1/2 JIC	Elbow fitting, stainless steel (material) double male 1/4 BSP - 1/2 JIC (# 5 JIC)	Winkelnippel, Edelstahl (Material) AG 1/4 BSP - AG 1/2 JIC	Racor acodado inoxidable (producto) M 1/4 BSP - M 1/2 JIC

Ind	#	Désignation	Description	Bezeichnung	Denominación
60	049 351 000	Support de fixation pour pistolet (Ø 16 mm longueur : 100 mm)	Mounting rod (Ø 16 mm - 5/8" length : 100 mm / 4")	Pistolenhalterung (Ø 16 mm Länge : 100 mm)	Soporte de fijación para pistola (Ø 16 mm longitud : 100 mm)
61		Aiguilles de débouchage (x 12) pour buses :	Unclogging needles (pack of 12) for tips :	Düsenreinigungsnadeln (12 St.) für Düsen :	Agujas desobturadoras (bolsa de 12) para boquillas :
	000 094.000	de 03 à 09	size 03 to 09	von 03 to 09	de 03 a 09
	000 094 002	de 12 à 30	size 12 to 30	von 12 to 30	de 12 a 30
62	075 800 001	Allonge droite longueur : 250 mm	10" Extension, straight	Verlängerung 250 mm gerade	Prolongador 250 mm, recto
	075 800 002	Allonge droite longueur : 400 mm	16" Extension, straight	Verlängerung 400 mm gerade	Prolongador 400 mm, recto
	075 850 001	Allonge coudée 45°, longueur : 250 mm	10" Extension with 45 degree swivel	Verlängerung 250 mm gerade, Kopf 45° abgewinkelt	Prolongador 250 mm, codo a 45°

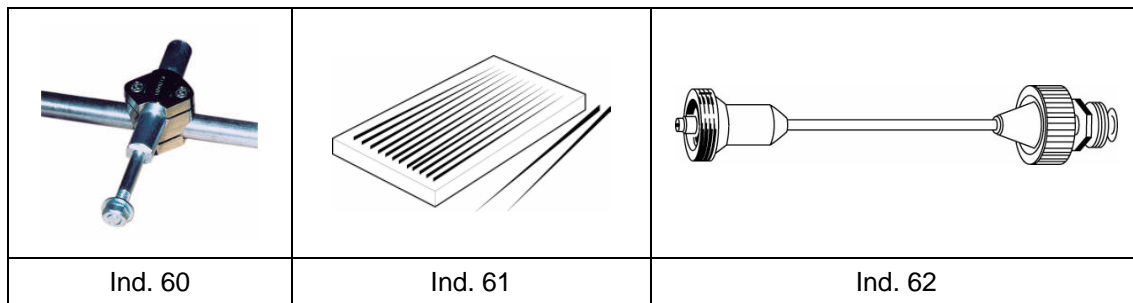

### ATX (pour fûts / for drums / für Fässer / para bidones)

<b>PISTOLET ATX - special fûts (avec embase)</b>	<b>ATX GUN, for drums (with base)</b>	<b>#</b>  <b>129.626.500</b>
<b>PISTOLE ATX - Speziell für Fässer (mit Grundplatte)</b>	<b>PISTOLA ATX para bidones (con base)</b>	

Ind	#	Désignation	Description	Bezeichnung	Denominación	Qté
-	129 626 505	Pistolet sans embase	Gun without base	Pistole ohne Grundplatte	Pistola sin base	1
40	129 626 510	Embase	Base	Grundplatte	Base	1

<b>PISTOLET ATX - spécial fûts (sans embase)</b>	<b>ATX GUN - special drums (without base)</b>	<b>#</b>  <b>129.626.505</b>
<b>PISTOLE ATX - Speziell für Fässer (ohne Grundplatte)</b>	<b>PISTOLA ATX - especial para bidones (sin base)</b>	

**Pièces spécifiques - Specific parts - Spezifische Teile - Partes específicas**

Ind	#	Désignation	Description	Bezeichnung	Denominación	Qté
10	029 626 501	Corps pistolet en inox	Gun body, stainless steel	Pistolenkörper, Edelstahl	Cuerpo pistola inox	1
<b>*30</b>	<b>129 622 100</b>	<b>Porte-siège assemblé</b>	<b>Seat-holder assembly</b>	<b>Düsennadelsitz, komplett</b>	<b>Porta-asiento montado</b>	<b>1</b>
31	029 620 501	• Porte-siège	• Seat-holder	• Düsennadelsitz	• Porta-asiento	1
*32	129 609 911	• Siège en résine acétale (les 10)	• Seat, acetal resin (pack of 10)	• Sitz in Acetalharz (10 St.)	• Asiento en resina acetabo (bolsa de 10)	1
34	029 600 106	• Vis	• Screw	• Schraube	• Tornillo	1
35	129 609 902	• Joint du porte-siège (les 10)	• Seal, seat-holder (pack of 10)	• Dichtung, Düsennadelsitz (10 St.)	• Junta porta-asiento (bolsa de 10)	1
36	129 629 914	• Joint torique (les 10)	• O-Ring (pack of 10)	• O-Ring (10 St.)	• Junta torica (x 10)	1

**OPTIONS - ON REQUEST - OPTIONEN - OPCIONES**

Ind	#	Désignation	Description	Bezeichnung	Denominación
32	129 629 923	Siège en inox avec joint (les 2)	Seat with seal (stainless steel) (pack of 2)	Nadelsitz-Einsatz in Edelstahl (2 St.)	Asiento inox con junta (bolsa de 2)
32	129 659 904	Siège en carbure avec joint (les 2)	Seat with seal, carbide (pack of 2)	Nadelsitz aus Hartmetall und Dichtring (2 St.)	Asiento carburo con junta (bolsa de 2)

<b>EMBASE INOX pour ATX - spécial fûts (ind. 40)</b>	<b>STAINLESS STEEL BARE for ATX gun - special drums (ind. 40)</b>	<b>#</b>  <b>129.626.510</b>
<b>GRUNDPLATTE (EDELSTAHL) für ATX-Pistole - Speziell für Fässer (Pos. 40)</b>	<b>BASE INOX para pistola ATX - especial para bidones (ind. 40)</b>	

Ind	#	Désignation	Description	Bezeichnung	Denominación	Qté
41	NC / NS	Embase sans insert	Base without insert	Grundplatte ohne Insert	Base sin inserto	1
42	NC / NS	Insert inox	Insert, stainless steel	Insert, Edelstahl	Inserto inox	1
43	933 151 221	Vis CHc M 5x16	Screw CHc M 5x16	Schraube M 5x16	Tornillo, CHc M 5x16	2
44	029 650 002	Bouchon	Plug	Stopfen	Tapón	1
47	905 121 006	Raccord (commande)	Fitting, quick release (control)	Schlauchanschluss für (Steuerluft)	Racor (mando)	1
48	905 121 007	Raccord (air) M 1/4 NPT - T8	Fitting (air) M 1/4 NPT - T8	Nippel (Luft) AG 1/4 NPT - T8	Racor (aire) M 1/4 NPT - T8	1
49	000 972 176	Raccord coudé inoxydable (produit) M 1/4 NPT - M 1/2 JIC	Elbow fitting, corrosion resistant (material) - double male 1/4 NPT - 1/2 JIC (# 5 JIC)	Winkelnippel, rostfrei (Material) AG 1/4 NPT - AG 1/2 JIC	Racor acodado inoxidable (producto) M 1/4 NPT - M 1/2 JIC	2



# **AIRMIX® AUTOMATIC SPRAY GUN**

## ***PREVENTIVE MAINTENANCE***

### **TRANSLATION FROM THE ORIGINAL MANUAL**

***IMPORTANT : Before assembly and start-up, please read and clearly understand all the documents relating to this equipment (professional use only).***

THE PICTURES AND DRAWINGS ARE NON CONTRACTUAL. WE RESERVE THE RIGHT TO MAKE CHANGES WITHOUT PRIOR NOTICE.

#### **KREMLIN - REXSON**

150, avenue de Stalingrad

93 245 - STAINS CEDEX – France

**☎** : 33 (0)1 49 40 25 25      **Fax** : 33 (0)1 48 26 07 16

**[www.kremlin-rexson.com](http://www.kremlin-rexson.com)**

Do not use fluid which would quickly clog the filter or would often block the spray tip.

Air supply should be clean.

The gun is a precision instrument and it relies on good and frequent maintenance for its correct operation. When it is carried out directly after use, the cleaning of the gun is faster and easier.

**Never use metal brushes files, points or clips for dismantling.**

Whenever possible, during the course of the day, clean the outside of the spray tip with a soft brush.

Use a tip unclogging needle of the proper size.

▪ **SHORT DURATION SHUTDOWN (LESS THAN 3 HOURS)**

Remove the paint on the air cap with a brush and solvent. Otherwise, leave the equipment as it is. Removing the paint will prevent the drying and clogging of the holes.

▪ **LONG DURATION SHUTDOWN**

Depressurize the fluid systems.

Unscrew the air cap. Remove the spray tip and soak it in solvent.

Use a tip unclogging needle of the proper size.

Flush the installation and leave it full of solvent.

➡ **Never soak the gun in solvent.**

➡ **Always make sure white seal or micro-filter are in place in the spray tip.**





# **AIRMIX® AUTOMATIC SPRAY GUN**

## ***TROUBLESHOOTING GUIDE***

### **TRANSLATION FROM THE ORIGINAL MANUAL**

***IMPORTANT : Before assembly and start-up, please read and clearly understand all the documents relating to this equipment (professional use only).***

THE PICTURES AND DRAWINGS ARE NON CONTRACTUAL. WE RESERVE THE RIGHT TO MAKE CHANGES WITHOUT PRIOR NOTICE.



#### **KREMLIN - REXSON**

150, avenue de Stalingrad

93 245 - STAINS CEDEX – France

**☎** : 33 (0)1 49 40 25 25      **Fax** : 33 (0)1 48 26 07 16

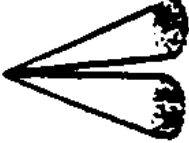
**[www.kremlin-rexson.com](http://www.kremlin-rexson.com)**

TROUBLE	CAUSE	SOLUTION
No fluid out of the gun	Tip is blocked	Shut off pressure on pump. Depressurize the hoses. Remove and clean spray tip and filter.
Low flow rate	Filter is partially clogged	
Spray fan is not uniform 	Tip is partially clogged	
Spray fan is not uniform 	Air holes in air cap are partially blocked	Remove and clean with solvent.  Blow all air holes clear with compressed air.
Excessive fluid fog	Too much atomizing air	Reduce atomizing air with the air regulator.
Pattern width narrows during reversing phase of pump	Air trapped in the fluid circuit  Viscosity too high	Check connection and suction hose quality.  Reduce viscosity.
Air cap becomes dirty frequently	Too much air Seat-holder leaking	Reduce air pressure. Replace it.
Fluid seeping from the air holes of the air cap	Defective tip seal Retaining ring loose	Replace it. Tighten it.
Fluid leak through leakage detector	Cartridge worn	Replace cartridge.
No change in pattern width	Air leak in front of the gun	Replace air adjuster.



# **AUTOMATIC AIRMIX® GUN**

## ***ATOMIZATION PRINCIPLE, OPERATING AND HANDLING***

### **TRANSLATION FROM THE ORIGINAL MANUAL**

***IMPORTANT : Before assembly and start-up, please read and clearly understand all the documents relating to this equipment (professional use only).***

THE PICTURES AND DRAWINGS ARE NON CONTRACTUAL. WE RESERVE THE RIGHT TO MAKE CHANGES WITHOUT PRIOR NOTICE.

#### **KREMLIN - REXSON**

150, avenue de Stalingrad

93 245 - STAINS CEDEX – France

**☎** : 33 (0)1 49 40 25 25      **Fax** : 33 (0)1 48 26 07 16

**[www.kremlin-rexson.com](http://www.kremlin-rexson.com)**

## 1. AIRMIX® ATOMIZATION PRINCIPLE

The spray air cap of the AIRMIX® gun is composed of 2 functional elements : a spray tip and an air cap. Atomization takes place in two phases :

1. The fluid is pre-atomized by going through the spray tip under pressure.
2. Atomization is improved by means of very low pressure atomizing air jets.

The end results is a fine uniform atomization that guarantees an excellent finish without excessive overspray. This results in very important air and fluid savings and cleaner working conditions - in comparison with a conventional air spray gun.

## 2. OPERATING



### Safety instructions :

- Never try to stop the spray fan with any part of the body (hands, fingers...) or with rags. Never point the spray gun at anyone or at any part of the body.
- The operator will need medical attention if the high pressure material spray is in contact with the the body (eyes, fingers...).
- **Always lock the gun trigger with the safety device when not operating the gun.**
- **Always depressurize air and hoses** before carrying out any servicing on the gun.



**In order to protect the operator, protective clothing (gloves, respirator mask, glasses, hearing protective earplug, clothes...) are required.**  
**Use the equipment in a properly ventilated area.**

- 1 - Prime the pump.
- 2 - Unscrew the air adjuster on the base of the gun.
- 3 - Select a spray tip (refer to AIRMIX® spray tip chart).
- 4 - Make sure white seal (or micro-filter) is in place in the spray tip.
- 5 - Carefully press the spray tip into the air cap back being certain the locating pins are aligned with mating recesses of the tip.
- 6 - Insert the air cap with its tip into the retaining ring. Screw retaining ring and air cap firmly onto the spray gun positioning the air cap to obtain the desired pattern orientation.
- 7 - Adjust the air pressure for the desired flow rate.
- 8 - If tails or heavy deposits of sprayed material occur at the ends of the pattern, increase the atomizing air pressure until the pattern is even.
- 9 - If using an adjustable air cap, pattern width can be optimized with the air adjusting knob.

Nota : if more material or less material are required, select another spray tip (refer to AIRMIX® spray tip chart).

### 3. GUN HANDLING

When mounting the air cap on the gun, hold it vertically in order to correctly adjust the air cap before screwing the air cap ring.

Keep the gun perpendicular to the surface to be painted.

Do not forget that crossed sweeps cannot correct irregularities.

Spraying from a stationary gun will not give even coverage.

Make sure that overlapping from the passes is even (gun moving vertically, part moving horizontally).

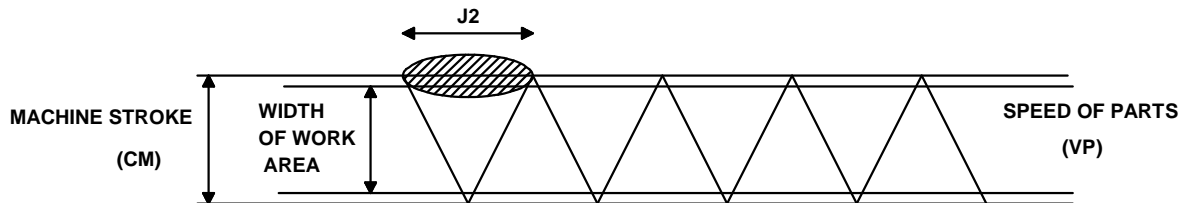

This width J2 for two regular coats of paint corresponds exactly to the following formula :

$$J2 \text{ (m)} = VP \text{ (m/s)} \times 2 \frac{CM \text{ (m)}}{VM \text{ (m/s)}}$$

Where :

**VP** = speed of travel of the parts to be painted.

**CM** = total stroke of the machine (and therefore of the spray guns).

**VM** = speed of the machine (and therefore of the spray guns).

**2** = 2 regular coats of paint (or 4 if you want to double the number of coats).

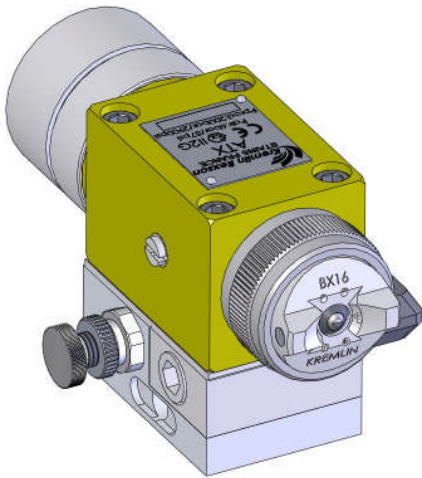

# **AUTOMATIC AIRMIX® GUN**

## **ATX**

### **TECHNICAL FEATURES**

## **TRANSLATION FROM THE ORIGINAL MANUAL**

***IMPORTANT : Before assembly and start-up, please read and clearly understand all the documents relating to this equipment (professional use only).***

THE PICTURES AND DRAWINGS ARE NON CONTRACTUAL. WE RESERVE THE RIGHT TO MAKE CHANGES WITHOUT PRIOR NOTICE.

### **KREMLIN - REXSON**

150, avenue de Stalingrad

93 245 - STAINS CEDEX – France

**☎** : 33 (0)1 49 40 25 25      **Fax** : 33 (0)1 48 26 07 16

**[www.kremlin-rexson.com](http://www.kremlin-rexson.com)**

## 1. DESCRIPTION

The ATX spray gun is designed for applying paints, primers and adhesives in automatic installations. It can be fitted on fixed supports, automatic machines or on robots.

The fitting of the gun using a modular base allows rapid interchangeability, which in turn leads to much reduced down time. Removal and replacement of the gun can be carried out without removing any hoses.

Non air bleeding gun, without spring in the fluid circuit.

## 2. TECHNICAL FEATURES

FEATURES	PISTOLET ATX, model standard	ATX GUN for drum
Maximum air supply pressure	6 bar / 87 psi	
Maximum fluid supply pressure	<b>200 bar / 2900 psi</b>	
Minimum command air pressure	3 bar / 44 psi	
Flow rate	Dependent type of nozzles (refer to chart)	
Weight (gun only)	750 g / 1.65 lb	
Weight (gun with base)	1060 g / 2.34 lb	
Operating maximum temperature	50°C / 122°F	
Air consumption	From 3 to 5 m <sup>3</sup> /h	
Wetted parts	Stainless- treated stainless steel	
Seat (removal)	Stainless	Polyacetale

Base	Option available	Standard available
Material (base)	Aluminium with stainless steel insert	
Fluid circulation	Into base	Into the gun

Note : For HVLP compliance, the maximum inlet air pressure at the gun base or handle must not exceed 14.35 psi (0,99 bar) to maintain 10 psi (0,68 bar) or less at the air cap. Testing for HVLP compliance was performed using the specified HVLP test air cap, the fan control fully closed and a pressure gauge on the air inlet fitting at the gun base or handle. It may also be a requirement of some regulatory agencies that users have the appropriate test air cap available on site to verify that the gun is being operated within the regulatory limitations

▪ AIR AND FLUID FITTINGS WITH HOSES

Gun	Supply	Threadings (base)	Fittings (base)	Hoses
standard	Fluid	F 1/4 NPS	M 1/2 JIC	Blue AIRMIX® hose, <b>conductive</b> , Ø 4,8 mm (3/16") or 6,35 mm (1/4")
	ATX			
	Spraying air	F 1/4 NPS	M 1/4 NPS	Air hose : minimum ID 7 mm (for a 7,5 m length),
	Command air	F 1/8 NPS	Quick-fit	Polyamide hose Ø 4x6

ATX	Fluid	F 1/4 NPS	M 1/2 JIC	Blue AIRMIX® hose, <b>conductive</b> , Ø 4,8 mm (3/16") or 6,35 mm (1/4")
	For drum			
	Spraying air	F 1/4 NPS	Quick-fit	Polyamide hose Ø 5/16"
	Command air	F 1/8 NPS	Quick-fit	Polyamide hose Ø 1/4"

On the modular base, you can fit :

- either 2 fluid fittings → fluid circulation
- or 1 product fitting and a plug



Applicate glue on the threading of the fluid fittings or of the plug before assembling (glue similar to Loctite 577).



The grounding of the gun will be carried out by means of the bracket (also grounded) or by means of a conductive material hose.

▪ DIMENSIONS

Ind.	A	B	C	D	E	F	G	H	I	J	K
mm	150	60	73	Ø 8	39	51	45	Ø 6	33	44	35,5
"	6	2.4	2.9	Ø 5/16	1.5	2	1.8	Ø 1/4	1.3	1.7	1.4

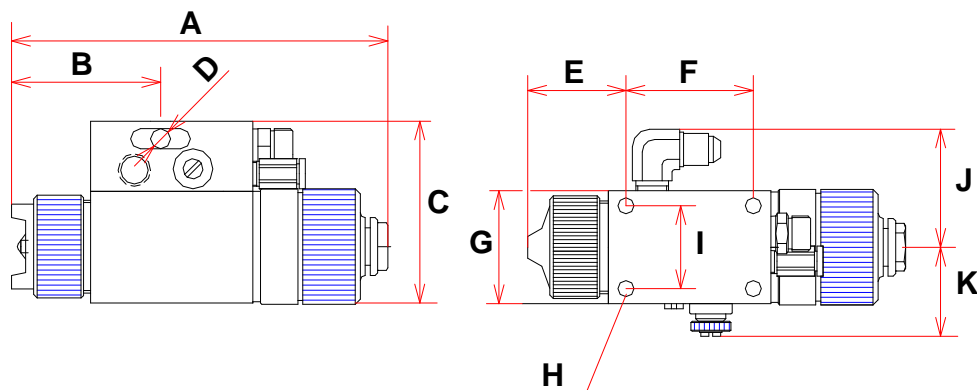

Fixing the gun onto its base : 4 screws M 6 x 50.

Fixing the complete assembly : rod Ø 16 / 5/8 ", length 100 mm / 4 ".



### 3. INSTALLATION

- DESCRIPTION OF THE LABEL MARKING

Marking in accordance with the ATEX Directive



<b>KREMLIN REXSON STAINS FRANCE</b>	Name and address of the manufacturer
<b>ATX</b>	Gun model
<b>CE Ex II 2 G</b>	<b>II</b> : group II <b>2</b> : class 2 Surface equipment meant to area where explosive atmospheres due to gas, vapours, mists are liable to appear from time to time in usual operating <b>G</b> : gas
<b>P air : 6 bar / 87 psi</b>	Gun air supply maximum pressure
<b>P prod : 200 bar / 2900 psi</b>	Maximum fluid pressure at the gun inlet
-	Number given by KREMLIN REXSON. The two first numbers indicate the manufacturing year.

▪ **INSTALLATION DIAGRAM**

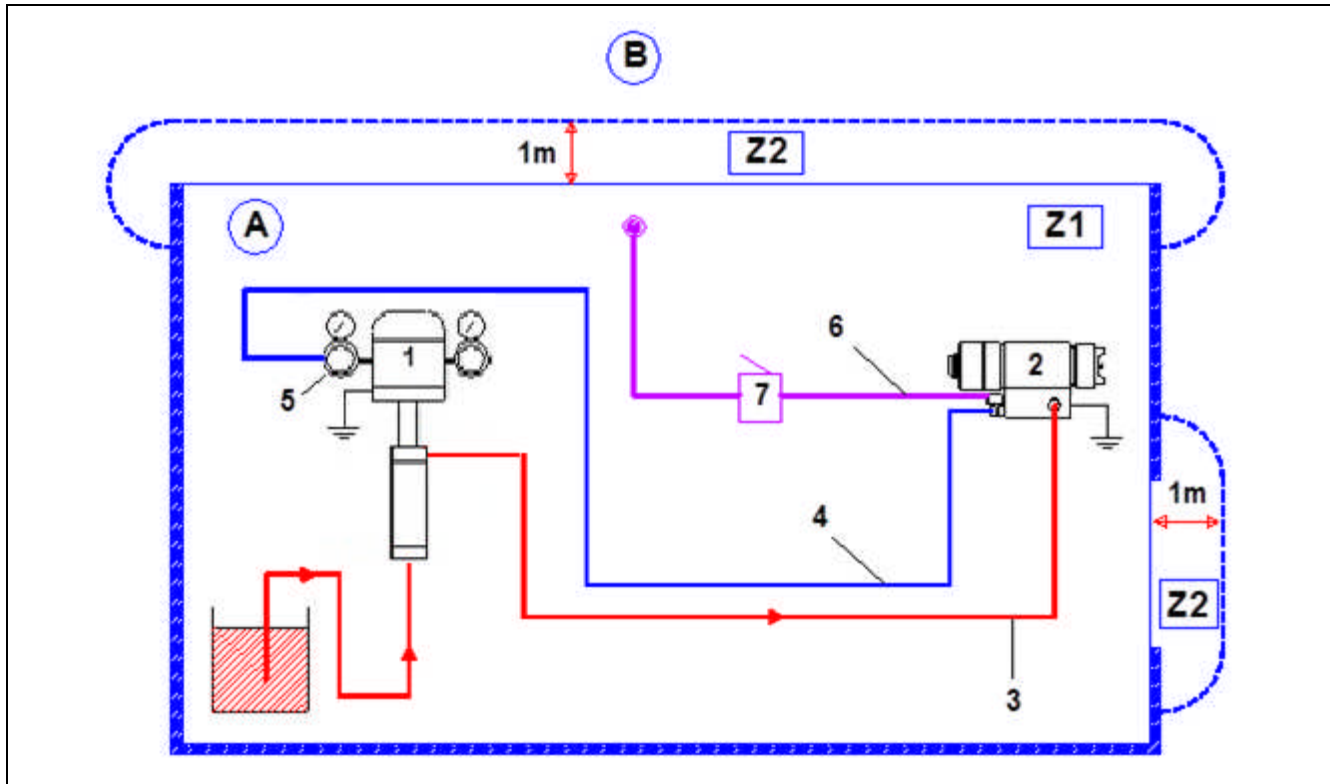

Captions :

A	Explosive area area 1 (Z1) or area 2 (Z2) : spray booth	3	Fluid hose
B	Non explosive area	4	<b>Conductive</b> air hose (spraying air)
		5	Air regulator
1	Pump	6	Air hose (control air)
2	Airmix® automatic gun	7	3 way-valve or electrovalve

- 1 - By means of a fluid hose (3), connect the gun fluid fitting to the pump. Tighten firmly the fittings.
- 2 - By means of a **conductive** air hose (4), connect the gun 'Spraying air' fitting (2) to an air regulator (5) that can supply at least 3 bar / 43.5 psi (→ spraying air).
- 3 - By means of an air hose (6), connect the gun 'Control air' fitting to the valve or the electrovalve (7) that will control the opening and the closing of the gun.

**A minimum pressure of 3 or 4 bar / 43.5 or 8 psi is necessary to control the gun (→ control air).**



Nota : The gun (and its eventual base) **must be** grounded by, **at least**, one of the three next solutions :

- by means of the fixing device on the machine,
- by means of the static conductive air hose,
- by means of the conductive or static conductive fluid hose.

The ground resistance between the gun and the floor must be  $\leq 1 \text{ M}\Omega$ .



The 1 m / 39.37" distance indicated in these diagrams is given for information purposes only and hold harmless to KREMLIN REXSON. The user is responsible for the extraction and conditioning of the painting area where the equipment is used, for working conditions conditions (refer to EN 60079-10 standard). The 1 m / 39.37" distance may be modified if trials carried out by the user deem this necessary.