



DOCUMENTATION - DOKUMENTATION - DOCUMENTACIÓN

MACHINE DE DOSAGE ELECTRONIQUE / ELECTRONIC MIXING MACHINE /  
ELEKTRONISCHE 2-K ANKLAGE / MÁQUINA DE DOSIFICACIÓN ELECTRÓNICA

**PU 3000**

**2L 1/1**

Notice / Manual / Betriebsanleitung / Libro : 582.001.110 - 1605

Date / Datum / Fecha : 27/05/16

Annule / Supersede / Ersetzt / Anula :

Modif. / Änderung :

**NOTICE ORIGINALE / TRANSLATION FROM THE ORIGINAL MANUAL**  
**/ ÜBERSETZUNG DER ORIGINAL BETRIEBSANLEITUNG**  
**/ TRADUCCIÓN DEL MANUAL ORIGINAL**

**IMPORTANT : Lire attentivement tous les documents avant le stockage, l'installation ou la mise en service du matériel concerné (à usage strictement professionnel).**

**Before assembly and start-up, please read and clearly understand all the documents relating to this equipment (professional use only).**

**WICHTIGER HINWEIS: Vor Lagerung, Installation oder Inbetriebnahme des Geräts bitte sämtliche Dokumente sorgfältig lesen (Einsatz nur von geschultem Personal).**

**IMPORTANTE : Lea con atención todos los documentos antes de almacenar, instalar o poner en marcha el equipo (uso exclusivamente profesional).**

PHOTOS ET ILLUSTRATIONS NON CONTRACTUELLES. MATERIELS SUJETS A MODIFICATION(S) SANS PREAVIS.

THE PICTURES AND DRAWINGS ARE NON CONTRACTUAL. WE RESERVE THE RIGHT TO MAKE CHANGES WITHOUT PRIOR NOTICE.

ALLE IN DIESEM DOKUMENT ENTHALTENEN SCHRIFTLICHEN ANGABEN UND ABBILDUNGEN STELLEN DIE NEUESTEN

PRODUKTINFORMATIONEN DAR. WIR BEHALTEN UNS DAS RECHT VOR, JEDERZEIT OHNE VORANKÜNDIGUNG ÄNDERUNGEN VORZUNEHMEN.

LAS FOTOGRAFÍAS E ILUSTRACIONES NO SON VINCULANTES. LOS MATERIALES ESTÁN SUJETOS A CAMBIOS SIN PREVIO AVISO.

**KREMLIN - REXSON**

150, avenue de Stalingrad

93 245 - STAINS CEDEX - France

☎ : 33 (0)1 49 40 25 25      Fax : 33 (0)1 48 26 07 16

**www.kremlin-rexson.com**



<p align="center"><b>FR</b></p> <p><b>Pour une utilisation sûre, il est de votre responsabilité de :</b></p> <ul style="list-style-type: none"> <li>• Lire attentivement tous les documents contenus dans le CD joint avant la mise en service de l'équipement,</li> <li>• D'installer, d'utiliser, d'entretenir et de réparer l'équipement conformément aux préconisations de KREMLIN REXSON ainsi qu'aux réglementations nationales et/ou locales,</li> <li>• Vous assurez que les utilisateurs de cet équipement ont été formés, ont parfaitement compris les règles de sécurité et qu'ils les appliquent.</li> </ul>	<p align="center"><b>UK</b></p> <p><b>To ensure safe use of the machinery, it is your responsibility to:</b></p> <ul style="list-style-type: none"> <li>• Carefully read all documents contained on the enclosed CD before putting the machinery into service,</li> <li>• Install, use, maintain and repair the machinery in accordance with KREMLIN REXSON's recommendations and national and/or local regulations,</li> <li>• Make sure that the users of the machinery have received proper training and that they have perfectly understood the safety rules and apply them.</li> </ul>	<p align="center"><b>DE</b></p> <p><b>Eine sichere Nutzung setzt voraus, dass Sie: :</b></p> <ul style="list-style-type: none"> <li>• alle in der CD enthaltenen Dokumente vor der Inbetriebnahme der Anlage aufmerksam lesen,</li> <li>• die Anlage im Einklang mit den Empfehlungen von KREMLIN REXSON sowie mit den nationalen und/oder lokalen Bestimmungen installieren, verwenden, warten und reparieren,</li> <li>• sich vergewissern, dass die Nutzer dieser Anlage angemessen geschult wurden, die Sicherheitsbestimmungen verstanden haben und sie anwenden.</li> </ul>
<p align="center"><b>ES</b></p> <p><b>Para una utilización segura, será de su responsabilidad:</b></p> <ul style="list-style-type: none"> <li>• leer atentamente todos los documentos que se incluyen en el CD adjunto antes de la puesta en servicio del equipo,</li> <li>• instalar, utilizar, efectuar el mantenimiento y reparar el equipo con arreglo a las recomendaciones de KREMLIN REXSON y a la normativa nacional y/o local,</li> <li>• cerciorarse de que los usuarios de este equipo han recibido la formación necesaria, han entendido perfectamente las normas de seguridad y las aplican.</li> </ul>	<p align="center"><b>IT</b></p> <p><b>Per un uso sicuro, vi invitiamo a:</b></p> <ul style="list-style-type: none"> <li>• leggere attentamente tutta la documentazione contenuta nel CD allegato prima della messa in funzione dell'apparecchio,</li> <li>• installare, utilizzare, mantenere e riparare l'apparecchio rispettando le raccomandazioni di KREMLIN REXSON, nonché le normative nazionali e/o locali,</li> <li>• accertarvi che gli utilizzatori dell'apparecchio abbiano ricevuto adeguata formazione, abbiano perfettamente compreso le regole di sicurezza e le applichino.</li> </ul>	<p align="center"><b>PT</b></p> <p><b>Para uma utilização segura, é da sua responsabilidade:</b></p> <ul style="list-style-type: none"> <li>• Ler atentamente todos os documentos incluídos no CD em anexo antes de pôr o equipamento em funcionamento,</li> <li>• Proceder à instalação, utilização, manutenção e reparação do equipamento de acordo com as preconizações de KREMLIN REXSON, bem como com outros regulamentos nacionais e/ou locais aplicáveis,</li> <li>• Assegurar-se que os utilizadores do equipamento foram devidamente capacitados, compreenderam perfeitamente e aplicam as devidas regras de segurança.</li> </ul>
<p align="center"><b>NL</b></p> <p><b>Voor een veilig gebruik dient u:</b></p> <ul style="list-style-type: none"> <li>• alle document op de bijgevoegde cd aandachtig te lezen alvorens het apparaat in werking te stellen,</li> <li>• het apparaat te installeren, gebruiken, onderhouden en repareren volgens de door KREMLIN REXSON gegeven aanbevelingen en overeenkomstig de nationale en/of plaatselijke reglementeringen,</li> <li>• zeker te stellen dat de gebruikers van dit apparaat zijn opgeleid, de veiligheidsregels perfect hebben begrepen en dat zij die ook toepassen.</li> </ul>	<p align="center"><b>SE</b></p> <p><b>För en säker användning av utrustningen ansvarar ni för följande:</b></p> <ul style="list-style-type: none"> <li>• Läs noga samtliga dokument som finns på den medföljande cd-skivan innan utrustningen tas i drift.</li> <li>• Installera, använd, underhåll och reparera utrustningen enligt anvisningarna från KREMLIN REXSON och enligt nationella och/eller lokala bestämmelser.</li> <li>• Försäkra er om att användare av denna utrustning erhållit utbildning, till fullo förstått säkerhetsföreskrifterna och tillämpar dem.</li> </ul>	<p align="center"><b>FI</b></p> <p><b>Käytön turvallisuuden varmistamiseksi velvollisuutesi on:</b></p> <ul style="list-style-type: none"> <li>• Lukea huolella kaikki CD:llä olevat asiakirjat ennen laitteiston käyttöönottoa,</li> <li>• Noudattaa laitteiston asennuksessa, käytössä, kunnossapidossa ja huollossa KREMLIN REXSON in suosituksia sekä kansallisia ja/tai paikallisia määräyksiä,</li> <li>• Varmistaa, että laitteiston käyttäjät ovat koulutettuja ja ymmärtävät täysin turvallisuusmääräykset ja miten niitä sovelletaan.</li> </ul>
<p align="center"><b>PL</b></p> <p><b>Dla zapewnienia bezpiecznego użytkowania na użytkownika spoczywa obowiązek:</b></p> <ul style="list-style-type: none"> <li>• Uważnego zapoznania się ze wszystkimi dokumentami znajdującymi się na załączonej płycie CD przed pierwszym uruchomieniem urządzenia,</li> <li>• Instalowania, użytkowania, konserwacji i naprawy urządzenia zgodnie z zaleceniami firmy KREMLIN REXSON oraz z przepisami miejscowymi,</li> <li>• Upewnienia, że wszyscy przeszkoleni użytkownicy urządzenia zrozumieli zasady bezpieczeństwa i stosują się do nich.</li> </ul>	<p align="center"><b>CS</b></p> <p><b>Pro bezpečné používání jste povinni:</b></p> <ul style="list-style-type: none"> <li>• Před uvedením zařízení do provozu si pozorně přečíst veškeré dokumenty obsažené na příloženém CD,</li> <li>• Nainstalovat, používat, udržovat a opravovat zařízení v souladu s pokyny firmy KREMLIN REXSON a s národními a/nebo místními legislativními předpisy,</li> <li>• Ujistit se, že uživatelé tohoto zařízení byli vyškoleni, že dokonale pochopili bezpečnostní pravidla a že je dodržují.</li> </ul>	<p align="center"><b>RU</b></p> <p><b>Для целей безопасного использования необходимо:</b></p> <ul style="list-style-type: none"> <li>• Ознакомиться со всеми документами, содержащимися в прилагаемом компакт-диске до ввода оборудования в эксплуатацию;</li> <li>• Устанавливать, использовать, производить техническое обслуживание и ремонт оборудования в соответствии с рекомендациями KREMLIN REXSON и национальным и/или местным законодательством;</li> <li>• Убедиться, что пользователи настоящего оборудования прошли подготовку, надлежащим образом усвоили правила безопасности и обеспечивают их соблюдение.</li> </ul>

Déclaration(s) de conformité au verso de ce document / Declaration(s) of conformity at the back of this document / Konformitätserklärung(en) auf der Rückseite dieser Unterlage / Declaración (es) de conformidad en el reverso de este documento / Dichiarazione/i di conformità sul retro del presente documento / Declaração(ões) de conformidade no verso do documento / Conformiteitsverklaring(en) op de keerzijde van dit document / Försäkran om överensstämmelse på omstående sida av detta dokument / Vaatimustenmukaisuusvakuutukset tämän asiakirjan kääntöpuolella / Deklaracja(e) zgodności na odwrocie dokumentu / Prohlášení o shodě se nachází/nacházejí na zadní straně tohoto dokumentu / Сертификат(ы) соответствия расположены на оборотной стороне настоящего документа

**DECLARATION D'INCORPORATION**  
**DECLARATION OF INCORPORATION**  
**EINBAUERKLÄRUNG**  
**DECLARACIÓN DE INCORPORACIÓN**  
**DICHIARAZIONE DI INCORPORAZIONE**  
**DECLARAÇÃO DE INCORPORAÇÃO**  
**INBOUWVERKLARING**  
**FÖRSÄKRAN FÖR INBYGGNAD**  
**DEKLARACJA WŁĄCZENIA**  
**PROHLÁŠENÍ O ZAČLENĚNÍ**  
**ДЕКЛАРАЦИЯ О СООТВЕТСТВИИ**  
**КОМПЛЕКТУЮЩИХ ИЗДЕЛИЙ**

Le fabricant / The manufacturer / Der Hersteller / El fabricante / Il produttore / O fabricante / De fabrikant / Tillverkare / Valmistaja / Producent / Výrobce / Изготовитель:	<b>KREMLIN REXSON</b> 150, avenue de Stalingrad 93 240 - STAINS - FRANCE Tél. 33 (0)1 49 40 25 25 - Fax : 33 (0)1 48 26 07 16
--	--

Déclare que le matériel désigné ci-après / Herewith declares that the equipment / erklärt hiermit, dass die / Declara que el material designado a continuación / Dichiaro che il materiale sottoindicato / Declara que o material a seguir designado / verklaart dat de hieronder aangeduide apparatuur / Kungör att den utrustning som anges här nedan / ilmoittaa, että alla mainitut laitteistot / Oświadcza, że wymienione poniżej urządzenia / Prohlašuje, že níže uvedené vybavení / Декларирует, что ниженазванное оборудование:

**MACHINE DE DOSAGE BI-COMPOSANT / TWO-COMPONENT PROPORTIONING MACHINE**  
**ELEKTRONISCHE 2-K- ANLAGE / MÁQUINA DE DOSIFICACIÓN DOS COMPONENTES**

PU 3000

Est conforme à la législation d'harmonisation de l'Union applicable suivante / Is in conformity with the relevant Union harmonisation legislation / Erfüllt die einschlägigen Harmonisierungsrechtsvorschriften der Union / es conforme con la legislación de armonización pertinente de la Unión / è conforme alla pertinente normativa di armonizzazione dell'Unione / in overeenstemming met de desbetteffende harmonisatiewetgeving van de Unie / med den relevanta harmoniserade unionslagstiftningen / on asiaa koskevan unionin yhdenmukaistamislainsäädännön vaatimusten mukainen / jest zgodny z odnośnymi wymaganiami unijnego prawodawstwa harmonizacyjnego / Shoduje se s následující příslušnou evropskou harmonizační legislativou / Соответствует следующим стандартизированным нормам Союза.

Cette quasi-machine ne doit pas être mise en service avant que la machine finale dans laquelle elle doit être incorporée ait été déclarée conforme à la directive Machines 98/37/CE / This partly completed machinery must not be put into service until the final machinery in which it is to be incorporated has been declared in conformity with Directive 98/37/CE on Machinery / Die unvollständige Maschine darf erst in Betrieb genommen werden, wenn für die fertige Maschine, in die sie eingebaut werden soll, eine Konformitätserklärung mit der Maschinenrichtlinie 98/37/CE vorliegt / Esta quasi máquina no deberá ser puesta en servicio mientras la máquina final en la cual vaya a ser incorporada no haya sido declarada conforme a la Directiva 98/37/CE relativa a las máquinas / Questa quasi-macchina non deve essere messa in servizio finché la macchina finale in cui deve essere incorporata non è stata dichiarata conforme alla direttiva macchine 98/37/CE / Esta quase-máquina só deve ser posta em funcionamento quando a máquina final na qual deve ser incorporada tiver sido declarada em conformidade com as disposições pertinentes do anexo I da Directiva 98/37/CE relativa às Máquinas / Deze niet voltooide machine mag niet in dienst worden genomen voordat de afgewerkte machine, waarin zij moet worden ingebouwd, conform is verklaard aan de Machinerichtlijn 98/37/CE / Denna delvis fullbordade maskin får inte tas i drift innan den slutliga maskin i vilken den ska byggas in försäkrats överensstämma med maskindirektivet, 98/37/CE / Tätä puolivalmistetta ei saa ottaa käyttöön ennen kuin lopullisen koneen, johon se on määrä liittää, on ilmoitettu olevan konedirektiivin 98/37/EY mukainen / Niniejszej maszyny nieukończonyj nie można uruchomić bez uzyskania deklaracji zgodności z dyrektywą Maszynową 98/37/WE dla maszyny, której ma być częścią. / Toto neúplné strojní zařízení nesmí být uvedeno do provozu, dokud nebude strojní zařízení, do kterého je začleňováno, prohlášeno za shodné podle Směrnice 98/37/ES o strojních zařízeních / Настоящее незавершенное машинное устройство не может быть введено в эксплуатацию до тех пор, пока окончательная сборка машинного устройства, чью часть она составляет, не будет соответствовать Директиве 98/37/ЕС по безопасности машинного оборудования.



Dominique LAGOUGE

Directeur Général / Chief Executive Officer / Generaldirektor  
/ Director General / Direttore Generale / Director Geral / Algemeen  
Directeur / Generaldirektör / Pääjohtaja / Dyrektor Naczelny  
/ Dyrektor Generalny / Generální ředitel / Генеральный директор

Fait à Stains, le / Established in Stains, on / Geschehen zu Stains, am / En Stains, a / Redatto a Stains, / Vastgesteld te Stains, / Utformat i Stains, den / Stains, Ranska, / Sporządzono w Stains, dnia / Stains, dnia / Издано в г. Стен (Stains) 20/04/2016 - 04/20/2016



**DECLARATION UE DE CONFORMITE  
UE DECLARATION OF CONFORMITY  
EU- KONFORMITÄTSEKTLÄRUNG  
DECLARACIÓN UE DE CONFORMIDAD  
DICHIARAZIONE DI CONFORMITÀ UE  
DECLARAÇÃO UE DE CONFORMIDADE  
EU-CONFORMITEITSVERKLARING  
EU-FÖRSÄKRAN OM ÖVERENSSTÄMMELE  
EU- VAATIMUKSEN MUKAISUUSVAKUUTUS  
DEKLARACJA ZGODNOŚCI UE  
EU PROHLÁŠENÍ O SHODĚ  
ДЕКЛАРАЦИЯ О СООТВЕТСТВИИ НОРМАМ ЕС**



Le fabricant / The manufacturer / Der Hersteller / El fabricante / Il produttore / O fabricante / De fabrikant / Tillverkare / Valmistaja / Producent / Výrobce / Изготовитель:	<b>KREMLIN REXSON</b> 150, avenue de Stalingrad 93 240 - STAINS - FRANCE Tél. 33 (0)1 49 40 25 25 - Fax : 33 (0)1 48 26 07 16
--	--

Déclare que le matériel désigné ci-après / Herewith declares that the equipment / erklärt hiermit, dass die / Declara que el material designado a continuación / Dichiaro che il materiale sottoindicato / Declara que o material a seguir designado / verklaart dat de hieronder aangeduide apparatuur / Kungör att den utrustning som anges här nedan / ilmoittaa, että alla mainitut laitteistot / Oświadczka, że wymienione poniżej urządzenia / Prohlašuje, že níže uvedené vybavení / Декларирует, что ниже названное оборудование:

**MACHINE DE DOSAGE BI-COMPOSANT / TWO-COMPONENT PROPORTIONING MACHINE  
ELEKTRONISCHE 2-K- ANLAGE / MÁQUINA DE DOSIFICACIÓN DOS COMPONENTES**

PU 3000

Est conforme à la législation d'harmonisation de l'Union applicable suivante / Is in conformity with the relevant Union harmonisation legislation / Erfüllt die einschlägigen Harmonisierungsrechtsvorschriften der Union / es conforme con la legislación de armonización pertinente de la Unión / è conforme alla pertinente normativa di armonizzazione dell'Unione / in overeenstemming met de desbetreffende harmonisatiewetgeving van de Unie / med den relevanta harmoniserade unionslagstiftningen / on asiaa koskevan unionin yhdenmukaistamislainsäädännön vaatimusten mukainen / jest zgodny z odnośnymi wymaganiami unijnego prawodawstwa harmonizacyjnego / Shoduje se s následující příslušnou evropskou harmonizační legislativou / Соответствует следующим стандартизированным нормам Союза

Directive Basse Tension / Low Voltage Directive / Niederspannung-Richtlinie / Directiva Baja Tensión / Direttiva Bassa Tensione / Directiva de Baixa Tensão / Richtlijn Laagspanning / Lågspänningsdirektivet / Pienjännitedirektiivi / Dyrektywa Niskonapięciowa / Směrnice Pro Nízké Napětí / ДИРЕКТИВА О НИЗКОВОЛЬТНОМ ОБОРУДОВАНИИ En 60204-1:2006 + A1:2009	<b>2014/35/UE</b>								
Directive Compatibilité Electromagnétique / Electromagnetic Compatibility Directive / Richtlinie Für Elektromagnetische Verträglichkeit / Directiva de Compatibilidad Eletromagnética / Direttiva Compatibilita Elettromagnetica / Directiva relativa à Compatibilidade Eletromagnética / Richtlijn Elektromagnetische Compatibiliteit / Direktivet om Elektromagnetisk Kompatibilitet / EMC-direktivi / Dyrektywa Kompatybilności Elektromagnetycznej / Směrnice Pro Elektromagnetickou Kompatibilitu / ДИРЕКТИВА ОБ ЭЛЕКТРОМАГНИТНОЙ СОВМЕСТИМОСТИ EN 61000-6-2:2005 EN 61000-6-3:2007 + A1:2011	<b>2014/30/UE</b>								
Directive ATEX / ATEX Directive / ATEX Richtlinie / Directiva ATEX / Direttiva ATEX / Diretiva ATEX / ATEX-Richtlijn / ATEX-direktivet / ATEX-direktivi / Dyrektywa ATEX / Směrnice ATEX / Директива ATEX <b>Marquage Coffret de commande / Marking control box :</b>  II 2G [EEEx ia] IIA <b>Marquage Platine produit / Marking fluid module :</b>  II 2G IIA T3 Tous les composants électriques utilisés en zone 1 sont, individuellement conformes à la directive 2014/34/UE. Leur présence combinée au sein de l'assemblage ne met pas en évidence de risques supplémentaires entraînant une évaluation globale de type de la machine. / Each individual electrical component used in zone 1 is in conformity with the 2014/34/UE directive. Their combined presence in the assembly has not highlighted any additional risks that would necessitate a comprehensive assesment of this type of machinery.	<b>2014/34/UE</b>								
<table border="1"> <thead> <tr> <th>Matériel / Equipment</th> <th>N° d'agrément / Approval N°</th> </tr> </thead> <tbody> <tr> <td>Barrière Zener / Zener barrier</td> <td>BAS 01 ATEX 7005</td> </tr> <tr> <td>Electrovanne / Electrovalve ATEX</td> <td>LCIE 12 ATEX 3005 X</td> </tr> <tr> <td>Electrovanne / Electrovalve</td> <td>DEKRA 11 ATEX 0091 X</td> </tr> </tbody> </table>	Matériel / Equipment	N° d'agrément / Approval N°	Barrière Zener / Zener barrier	BAS 01 ATEX 7005	Electrovanne / Electrovalve ATEX	LCIE 12 ATEX 3005 X	Electrovanne / Electrovalve	DEKRA 11 ATEX 0091 X	
Matériel / Equipment	N° d'agrément / Approval N°								
Barrière Zener / Zener barrier	BAS 01 ATEX 7005								
Electrovanne / Electrovalve ATEX	LCIE 12 ATEX 3005 X								
Electrovanne / Electrovalve	DEKRA 11 ATEX 0091 X								

Dominique LAGOUGE

Directeur Général / Chief Executive Officer / Generaldirektor  
/ Director General / Direttore Generale / Director Geral / Algemeen  
Directeur / Generaldirektör / Pääjohtaja / Dyrektor Naczelny  
/ Dyrektor Generalny / Generální ředitel / Генеральный директор

Fait à Stains, le / Established in Stains, on / Geschehen zu Stains, am / En Stains, a / Redatto a Stains, / Vastgesteld te Stains, / Utformat i Stains, den / Stains, Ranska, / Sporządzono w Stains, dnia / Stains, dnia / Издано в г. Стен (Stains) 20/04/2016 - 04/20/2016



# INSTALLATION AND SAFETY INSTRUCTIONS

## TRANSLATION OF THE ORIGINAL MANUAL

**IMPORTANT** : Before assembly and start-up, please read and clearly understand all the documents relating to this equipment (professional use only).

*THE PICTURES AND DRAWINGS ARE NON CONTRACTUAL. WE RESERVE THE RIGHT TO MAKE CHANGES WITHOUT PRIOR NOTICE.*

### **KREMLIN - REXSON**

150, avenue de Stalingrad

93 245 - STAINS CEDEX – France

**☎** : 33 (0)1 49 40 25 25      *Fax* : 33 (0)1 48 26 07 16

**[www.kremlin-rexson.com](http://www.kremlin-rexson.com)**

# 1. SAFETY INSTRUCTIONS

## GENERAL SAFETY INSTRUCTIONS



**CAUTION :** The equipment can be dangerous if you do not follow our instructions concerning installation and servicing described in this manual and in accordance with applicable European standards and local national safety regulations.

Please carefully read all the instruction literature before operating your equipment.

**Only trained operators can use the equipment** (To acquire an essential training, please contact the "KREMLIN REXSON University" training center - Stains).

The foreman must ensure that the operator has understood the safety instructions for this equipment as well as the instructions in the manuals for the different parts and accessories.

Read carefully all instruction manuals, label markings before operating the equipment.



















Incorrect use may result in injury. This equipment is for professional use only. It must be used only for what it has been designed for. Never modify the equipment. The parts and accessories supplied must be regularly inspected. Defective or worn parts must be replaced.

**Guards (motor cover, coupling shields, connectors,...) have been designed for a safe use of the equipment.**  
**The manufacturer will not be held responsible for bodily injury or failure and / or property damage due to destruction, the overshadowing or the partial or total removal of the guards.**

**Never exceed the equipment components' maximum working pressure.**

Comply with regulations concerning safety, fire risks, electrical regulations in force in the country of final destination of the material. Use only products or solvent compatible with the parts in contact with the material (refer to data sheet of the material manufacturer).

## PICTOGRAMS

					
NIP HAZARD	WARNING MOVING ELEVATOR	WARNING MOVING PARTS	WARNING MOVING SHOVEL	DO NOT EXCEED THIS PRESSURE	HIGH PRESSURE HAZARD
					
RELIEF OR DRAIN VALVE	WARNING HOSE UNDER PRESSURE	WEAR GLASSES OBLIGATORY	WEAR OF GLOVES IS OBLIGATORY	PRODUCT VAPOR HAZARDS	WARNING HOT PARTS OR AREAS
					
ELECTRICAL HAZARD	WARNING FIRE HAZARDS	EXPLOSION HAZARDS	GROUNDING	WARNING (USER)	WARNING SERIOUS INJURIES

## FIRE - EXPLOSION - SPARKS - STATIC ELECTRICITY HAZARDS

A poor earth connection, inadequate ventilation, sparks or static electricity can cause an explosion or fire. to avoid these risks when using or servicing KREMLIN REXSON equipment, the following safety procedures must be followed :



- ensure a good earth connection and ground the parts to be handled i.e. solvents, materials, components and equipment,
- ensure adequate ventilation,
- keep working area clean and free from waste solvents, chemicals, or solid waste i.e. rags, paper and empty chemicals drums,
- never use electrical switches / power if in an atmosphere of volatile solvent vapour,
- stop working immediately in case of electrical arcs,
- never store chemicals and solvents in the working area.
- use paint whose flash point is the highest possible to prevent from any formation of gas and inflammable vapours (refer to materials' safety instructions),
- install a cover on the drums to reduce the diffusion of gas and vapours in the spraybooth.

## TOXIC PRODUCT HAZARDS

Toxic products or vapours can cause severe injury not only through contact with the body, but also if the products are ingested or inhaled. It is imperative :



- to know the material products and their risks,
- notified or hazardous materials must be stored in accordance with the regulations,
- the material must be stored in an appropriate container, never place materials in a container where there is a risk of spillage or leakage,
- a procedure must be applied for the safe disposal of waste material. It must comply with all prevailing regulations and legislations of the country where the equipment is to be used,
- protective clothing should always be worn in compliance with the material manufacturers' recommendations,
- depending on the application and chemical safety instructions, safety glasses, hearing protective earplug, gloves, foot wear, protective masks and possible breathing equipment should be worn to comply with the regulations (Refer to chapter "Safety equipment of KREMLIN selection guide).

### **CAUTION!**

It is forbidden to use material containing high concentrations of halogenated hydrocarbon solvents with **aluminium or zinc fillers** .Non-compliance with the instructions may cause explosion risk causing serious or fatal injury.

## EQUIPMENT REQUIREMENTS

**Guards (motor cover, coupling shields, connectors,...) have been designed for a safe use of the equipment.**

**The manufacturer will not be held responsible for bodily injury or failure and / or property damage due to destruction, the overshadowing or the partial or total removal of the guards.**

### **PUMP**



Before carrying out any work, it is imperative to read and clearly understand the disassembly and reassembly instructions before servicing. The operator must understand the equipment and the safety instructions. These instructions are available in the equipment manuals.



The air motor is designed to be mounted with a pump. Never modify any components or couplings. When operating, please keep hands away from moving parts. Before starting up the equipment, please read the PRESSURE RELIEF instructions. Please ensure that any relief or drain valves fitted are in good working order.

### **HOSES**

- Keep hoses out of circulation areas, moving parts or hot surfaces,
- Never expose product hoses to temperature higher than + 60°C / 140° F or lower than 0°C / 32° F,
- Never pull or use the hoses to move the equipment,
- Tighten all fittings as well as the hoses before operating the equipment,
- Check the hoses regularly; change them if they are damaged,
- Never exceed the working pressure (WP) indicated on the hose.

## USED PRODUCTS

Considering the wide variety of products that are available and can be used in our equipment it is impossible to check and make recommendations for all chemical data, regarding the risks of possible chemical attack and their long term chemical reaction

KREMLIN REXSON can not be held liable for :

- Compatibility of wetted parts,
- Risks to staff and the surroundings,
- for worn or defective parts, for faulty equipment or units, or the quality of final product.

It is the responsibility of the user to know and prevent any possible risks such as toxic vapours, fires or explosions. He shall determine the risks of immediate reactions or pursuant to repeated exposures of the staff,

KREMLIN REXSON shall not be liable for physical injuries, direct or indirect material damages caused by the use of chemicals.



## 2. HANDLING



### **Check the weight and the dimensions of the equipment**

**(☞ refer to 'Technical features' section of the instruction manual**

If weight and dimensions are too important, the unloading must be carried out by means of a forklift or any other appropriate means with a qualified personnel and in a clear horizontal area to prevent from risks of damage injury or an accident.

The centre of gravity is not in the centre of the machine : carry out by hand a stability-test after having lifted the whole at 10 cm / 3.937" maximum.

After the unloading, the handling of the whole (eg: elevator pump) is carried out by means of a pallet truck taking the bottom part of the frame.

**Remark : Each pump motor is fitted with a ring. The ring is designed for the hoisting of one pump and can not be used for the handling of the complete machine.**

## 3. STORING

Storing before installation :

- Storing ambient temperature : 0 / +50 °C / 0 / +122°F
- Protect the whole against dust, water trickling, dampness and shocks.

Storing after installation :

- Operating temperature : +15 / +35 °C / +59 / +138.2° F
- Protect the whole against dust, water trickling, dampness and shocks.

## 4. INSTALLATION OF THE EQUIPMENT

The machine is installed on a stable horizontal floor (for eg a concrete flag).



**To avoid risks caused by static electricity, the equipment as well as its components must be grounded.**

- **For the pumping equipments** (pumps, pneumatic rams, frame...), a section wire of 2.5 mm<sup>2</sup> is fixed on the material. Use this wire to connect the material to "the general ground". In case of severe environments (mechanical protection of the wire of earthing insufficient, vibrations, mobile material...) where function damages at the ground are probable, the user have to replace the provided wire of 2.5 mm<sup>2</sup> by a device more adapted to its environment (wire with a more important section, bonding strip, fixing by thimble with eyelet...),

The continuity of the ground must be controlled by a qualified electrician. If the continuity of the ground is not ensured, check the terminal, the wire and the earthing point. **Never** use the material without have solved this problem.

- In the severe cases of environments (mechanical protection of the wire of earthing insufficient, vibrations, mobile material...) where damages of the function put at the ground are probable, the user will have to replace the wire of 2.5 mm<sup>2</sup> provided, by a device more adapted to its environment (wire of more important section, bonding strip, fixing by thimble with eyelet...),
- **The gun** must be 'grounded' via a material hose or an air hose. In case of spraying by means of a gun with cup, the air hose must be conductive,
- **The materials to be painted** must also be grounded.

**All the materials situated in the working area shall be grounded.**



- **Never store** more than necessary inflammable materials inside the working area,
- The materials must be stored into **approved drums** and grounded,
- Use only grounded **metals containers** for the use of cleaning solvents,
- **Cardboard and paper are prohibited.**

## 5. MARKING OF THE EQUIPMENT

Each equipment has a marking plate.

The plate consists of the name of the manufacturer, the equipment part number and important information for correct use of the equipment (air pressure, electric power,...).



**INSTRUCTION MANUAL**  
**ELECTRONIC MIXING MACHINE PU 3000**

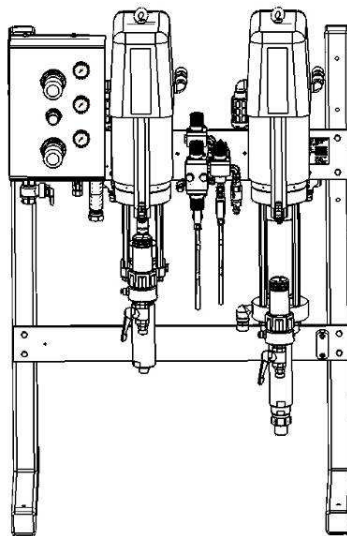

**Manual : 1403 573.199.112**

*Date : 12/03/14 - Cancels : 13/12/13*

*Modif. : + PU 3000 4 L 30/1 & PU 3000 4 L 53/1, § 1, § 2 , § 4, § 5, § 8, § 9, § 11, § 12.*

**TRANSLATION FROM THE ORIGINAL MANUAL**

***IMPORTANT : Before assembly and start-up, please read and clearly understand all the documents relating to this equipment (professional use only).***

*THE PICTURES AND DRAWINGS ARE NON CONTRACTUAL. WE RESERVE THE RIGHT TO MAKE CHANGES WITHOUT PRIOR NOTICE.*

**KREMLIN - REXSON**

150, avenue de Stalingrad  
93 245 - STAINS CEDEX – France

**☎ : 33 (0)1 49 40 25 25      Fax : 33 (0)1 48 26 07 16**

**[www.kremlin-rexson.com](http://www.kremlin-rexson.com)**



## TABLE OF CONTENTS

<b>1. SAFETY INSTRUCTIONS .....</b>	<b>6</b>
■ SPECIFIC SAFETY INSTRUCTIONS .....	6
■ ENVIRONMENT.....	7
■ ELECTROSTATIC INSTALLATION .....	7
<b>2. DESCRIPTION .....</b>	<b>8</b>
<b>3. OPERATING DESCRIPTION.....</b>	<b>10</b>
<b>4. FEATURES .....</b>	<b>10</b>
<b>5. INSTALLATION .....</b>	<b>11</b>
■ HANDLING.....	11
■ STORAGE.....	11
■ ENVIRONMENT ON THE AREA.....	11
■ DESCRIPTION OF THE LABEL MARKINGS.....	12
■ INSTALLATION DIAGRAM.....	13
■ INSTALLATION .....	14
■ CONNECTION OF THE CONTROL BOX AND OF THE FLUID FRAME .....	15
<b>6. OPERATING .....</b>	<b>16</b>
■ DRIVING FROM THE MACHINE.....	16
■ SWITCHING ON THE MACHINE .....	16
<b>7. FIRST SWITCHING ON .....</b>	<b>17</b>
<b>8. FIRST PLACING INTO OPERATION .....</b>	<b>18</b>
■ BEFORE SWITCHING ON .....	18
■ FLUSHING OF THE PUMPS AND OF THE MACHINE IN SOLVENT .....	18
■ START UP OF THE MACHINE .....	19
■ MIXING RATIO CHECKING .....	19
<b>9. APPLICATION PROGRAMMING (F3) .....</b>	<b>21</b>
■ PASSWORD .....	21
■ PROCEDURE TO GET THE VERSION NUMBER OF THE ELECTRONIC CARD.....	21
■ PARAMETERS .....	22
■ VALIDATION OF THE INITIALIZATION MODE .....	23
■ PRODUCTION (F1) .....	24
■ FLUSHING (F2) .....	25
■ CONSUMPTIONS / PRINT (F4) .....	25
■ DOWNLOADING DATA FROM PU 3000 TO A COMPUTER.....	27
■ DRUM REPLACEMENT PROCEDURE .....	31

<b>10. INDICATIONS OF OPERATION GIVEN BY THE MACHINE.....</b>	<b>32</b>
■ INDICATIONS GIVEN BY THE LEDS .....	32
■ MESSAGES GIVEN BY THE DISPLAY UNIT .....	32
<b>11. MAINTENANCE .....</b>	<b>33</b>
■ SYNOPTIC.....	33
■ MAINTENANCE PLAN.....	34
■ TROUBLESHOOTING.....	35
■ DIAGNOSTICS .....	35
<b>12. PROPORTION AND OUTPUT ACCORDING TO THE RATIO .....</b>	<b>37</b>
■ PU 3000 PNEUMATIC, AIRMIX® AND AIRLESS VERSIONS .....	37
■ PU 3000 4 L 30/1 AND 4 L 53/1 VERSIONS.....	38
<b>13. MIXING RATIO.....</b>	<b>39</b>
<b>14. PNEUMATIC AND ELECTRIC DIAGRAMS .....</b>	<b>39</b>
<b>15. FEATURES - PU 3000 PNEUMATIC.....</b>	<b>41</b>
■ COMPOSITION .....	41
■ TECHNICAL FEATURES .....	41
■ SPECIFIC PARAMETERS.....	41
<b>16. FEATURES - PU 3000 AIRMIX®.....</b>	<b>42</b>
■ COMPOSITION .....	42
■ TECHNICAL FEATURES .....	42
■ SPECIFIC PARAMETERS.....	42
<b>17. DISASSEMBLY &amp; REASSEMBLY - PU 3000 PNEUMATIC, PU 3000 AIRMIX® .....</b>	<b>43</b>
■ MIXER.....	43
■ PILOTED VALVES.....	43
■ FLUID SECTION, MODEL 50 (BASE) (REFER TO DOC. 573.080.050).....	44
■ FLUID SECTION, MODEL 50 F (CATALYST) (REFER TO DOC. 573.114.050).....	46
<b>18. FEATURES - PU 3000 AIRLESS.....</b>	<b>49</b>
■ COMPOSITION .....	49
■ TECHNICAL FEATURES .....	49
■ SPECIFIC PARAMETERS.....	49
<b>19. DISASSEMBLY &amp; REASSEMBLY - PU 3000 AIRLESS .....</b>	<b>50</b>
■ MIXER.....	50
■ ASI 40 VALVES (REFER TO DOC. 573.062.050).....	50
■ FLUID SECTION, MODEL ALTO 50CC (BASE & CATALYST) (REFER TO DOC. 573.395.050) .....	51

<b>20. FEATURES - PU 3000 4 L 30/1 .....</b>	<b>54</b>
■ COMPOSITION .....	54
■ TECHNICAL FEATURES .....	54
■ SPECIFIC PARAMETERS.....	54
<b>21. DISASSEMBLY &amp; REASSEMBLY - PU 3000 4 L 30/1 .....</b>	<b>55</b>
■ MIXER.....	55
■ ASI 40 VALVES (REFER TO DOC. 573.062.050).....	55
■ FLUID SECTION, MODEL ALTO 225CC (BASE & CATALYST) (REFER TO DOC. 573.451.050) .....	56
<b>22. FEATURES - PU 3000 4 L 53/1 .....</b>	<b>59</b>
■ COMPOSITION .....	59
■ TECHNICAL FEATURES .....	59
■ SPECIFIC PARAMETERS.....	59
<b>23. DISASSEMBLY &amp; REASSEMBLY - PU 3000 4 L 53/1 .....</b>	<b>60</b>
■ MIXER.....	60
■ ASI 40 VALVES (REFER TO DOC. 573.062.050).....	60
■ FLUID SECTION, MODEL MAJOR 227CC # 105 174 01 07 (BASE & CATALYST) (REFER TO DOC. 573.447.050) .....	61

**ADDITIONAL DOCUMENTATIONS :**

Incorporation declaration and EC declaration of conformity	578.013.130-UK
--	----------------

**PU 3000 PNEUMATIC**

	<b>Spare Parts</b>
PU 3000 Pneumatic Pump - Assembly	Doc. 573.404.050
Pneumatic motor, model 1500 (only for PU3000)	Doc. 573.437.050
BASE fluid section, model 50	Doc. 573.080.050
CATA fluid section, model 50 F	Doc. 573.114.050
Color changer and valve	Doc. 573.187.050 + Doc. 573.188.050
LP fluid regulator (Spring operated)	Doc. 573.203.110 + Doc. 573.415.050
HP fluid regulator, model 3/8 (260 bar / 3771 psi)	Doc. 573.299.050
Flushing pump, model EOS 02-C85	Doc. 573.457.050

**PU 3000 AIRMIX®**

	<b>Spare Parts</b>
PU 3000 Airmix Pump - Assembly	Doc. 573.386.050
Pneumatic motor, model 3000	Doc. 573.387.050
BASE fluid section, model 50	Doc. 573.080.050
CATA fluid section, model 50 F	Doc. 573.114.050
Color changer and valve	Doc. 573.187.050 + Doc. 573.188.050
Filter, model HP 3/8 (260 bar / 3770.8 psi)	Doc. 573.299.050
Flushing pump, model EOS 30-C25	Doc. 573.438.050

**PU 3000 AIRLESS**

	<b>Spare Parts</b>
PU 3000 Airless Pump - Assembly	Doc. 573.389.050
Pneumatic motor, model 5000	Doc. 573.390.050
BASE & CATA fluid section, model 50cc	Doc. 573.395.050
ASI 40 valve	Doc. 573.062.050
Filter, model HP 3/4 (360 bar / 5222 psi)	Doc. 573.327.050
Flushing pump, model EOS 30-C25	Doc. 573.438.050

**PU 3000 4 L 30/1**

	<b>Spare Parts</b>
PU 3000 4 L 30/1 PUMP - Assembly	Doc. 573.452.050
Pneumatic motor, Model 5000	Doc. 573.390.050
BASE & CATA fluid section, type 225cc	Doc. 573.451.050
ASI 40 valve	Doc. 573.062.050
Filter, model HP 3/4 (360 bar / 5222 psi)	Doc. 573.327.050
Flushing pump, model EOS 30-C25	Doc. 573.438.050

**PU 3000 4 L 53/1**

	<b>Spare Parts</b>
PU 3000 4 L 53/1 PUMP - Assembly	Doc. 573.453.050
Pneumatic motor, model 7000	Doc. 573.450.050
BASE & CATA fluid section, type 227cc	Doc. 573.447.050
ASI 40 valve	Doc. 573.062.050
Filter, model HP 3/4 (360 bar / 5222 psi)	Doc. 573.327.050
Flushing pump, model EOS 30-C25	Doc. 573.438.050

**DIAGRAMS**

Pneumatic and electric diagrams	055.680.031
---------------------------------	-------------



Dear Customer, You are the owner of our new PU 3000 mixing system and we would like to take this opportunity to thank you.

Special care has been taken during all designing and manufacturing process to make sure your investment will provide full satisfaction. Non-compliance with instructions and precautions stated in this manual could reduce the equipment working life, resulting in operating problems and create unsafe conditions.

## 1. SAFETY INSTRUCTIONS

### ■ GENERAL SAFETY INSTRUCTIONS



**CAUTION :** The equipment can be dangerous if you do not follow our instructions concerning installation and servicing described in this manual and in accordance with applicable European standards and local national safety regulations.

Please carefully read all the instruction literature before operating your equipment.

**Only trained operators can use the equipment** (To acquire an essential training, please contact the "KREMLIN REXSON University" training center - Stains).

The foreman must ensure that the operator has understood the safety instructions for this equipment as well as the instructions in the manuals for the different parts and accessories.

Read carefully all instruction manuals, label markings before operating the equipment.

Incorrect use may result in injury. This equipment is for professional use only. It must be used only for what it has been designed for. Never modify the equipment. The parts and accessories supplied must be regularly inspected. Defective or worn parts must be replaced.

**Never exceed the equipment components' maximum working pressure.**

Comply with regulations concerning safety, fire risks, electrical regulations in force in the country of final destination of the material. Use only products or solvent compatible with the parts in contact with the material (refer to data sheet of the material manufacturer).



**Refer to 'Installation and safety instructions' document  
(doc. 578.001.130)**

### ■ SPECIFIC SAFETY INSTRUCTIONS



The control box of the PU 3000 mixing machine shall be installed outside the explosive area. It shall be installed in a safe area (non-explosive area according to the ATEX directive - refer § 5).



Do not install the paint drums underneath the pumps or the electric equipments. Place them in front of the frame. Install a cover on the drums to reduce the diffusion of gas and vapours in the booth.



Connect the control box to the mains supply fitted with a ground.

The fluid module is fitted with a ground. Connect the ground cable to earth.

Do not use any product or solvent incompatible with the machine components.

Use the appropriate solvent for the material being sprayed to increase the equipment working life.



Wear protective glasses to protect the operator from possible discharges during the handling of the machine.



**CAUTION :** To prevent from any formation of gas and inflammable vapours, use paint whose flash point is the highest possible (refer to materials' safety instructions).

**Before cleaning or removing components of the equipment, it is compulsory :**

- 1 - to shut off the air supply,
- 2 - to open the gun fluid circuit and depressurize the hoses,
- 3 - to switch off the machine electrical supply.

#### ■ ENVIRONMENT

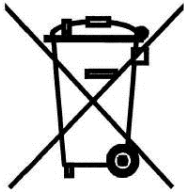

This equipment consists of a label plate with the name of the manufacturer, the equipment part number, the interesting informations to use correctly the equipment (pressure, voltage...) and the above pictogram.

The equipment is designed with and consists of high quality materials and components which can be re-used.

The 2002/96/EC European Directive covers all equipments with a crossed-out bin pictogram. Please inform yourself about the collection systems for electric and electronic equipments.

Please act in accordance with local rules and **do not dispose of old equipment with household wastes**. A correct disposal of old equipment will help prevent negative consequences for the environment and health.

#### ■ ELECTROSTATIC INSTALLATION

It is better not to use the equipment with water-based paints.

For paints with a resistivity > 5Mohm, we recommend you to consult Kremlin Rexson in order to integrate properly the unit.

## 2. DESCRIPTION

The PU 3000 proportioning system is designed for applying two component solvent or water-based paints and lacquers.

There are three versions available :

- a pneumatic version (maximum pressure : 0-6 bar / 0-87 psi or 6-40 bar / 87-580 psi)
- an AIRMIX® version (maximum pressure : 180 bar / 2610 psi),
- an AIRLESS version (maximum pressure : 350 bar / 5076 psi),
- a 4 L 30/1 version (maximum pressure : 180 bar / 2610 psi),
- a 4 L 53/1 version (maximum pressure : 350 bar / 5076 psi).

It is under an independant form only supplied with compressed air (maximum 6 bar / 87 psi) and an electric supply (115V / 230V).

It consists of :

- a control box with PLC and electromagnetic control components,
- a frame supporting a BASE pump, a CATALYST pump, the automatic valves for the materials and the solvent, and electropneumatic control components.

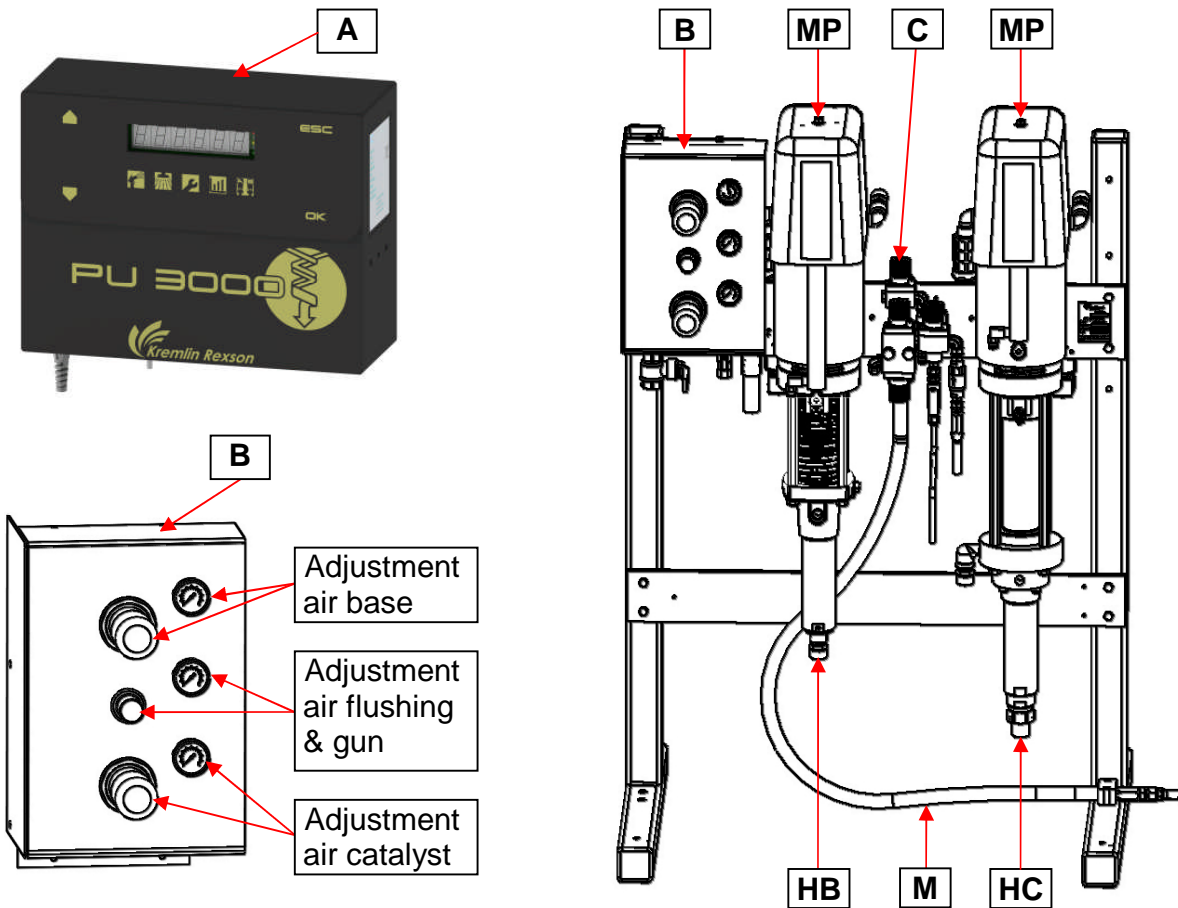

A : Electronic control box with display unit

B : Air equipment

C : Mixing unit

HB : BASE fluid section

HC : CATALYST fluid section

MP : Pneumatic motor

M : Mixer

Option : Flushing pump

Nota : drawing of a pump, unit PU 3000 Airmix®

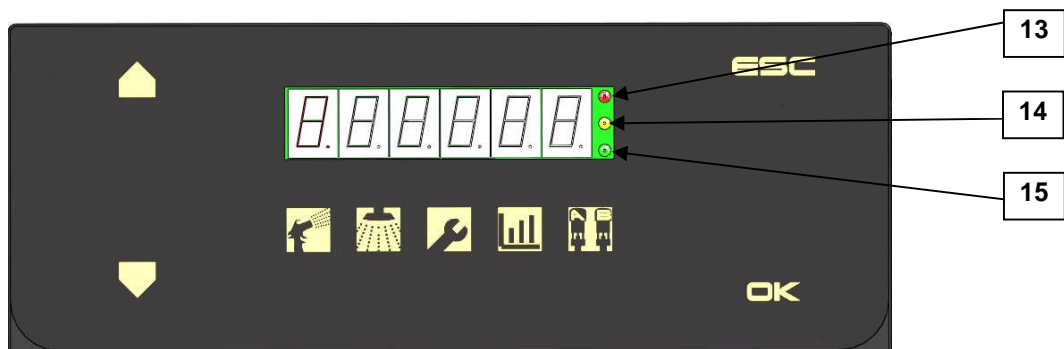

**FRONT VIEW OF THE CONTROL BOX**

Ind.	Description	Fonction
13	Red LED	Fault
14	Orange LED	Working (other than production)
15	Green LED	Production





The machine is totally programmable via a man/machine interface. The screen indicates continuously, by a simple identification, the status of the machine and it enables the operator to have access to the essential functionalities : ON / OFF - FLUSHING / PRODUCTION.

The information relating to the operating of the machine (real time display of the ratio, of the consumption...) can be read on the LCD screen.

The PU 3000 continuously saves data on the consumptions of base, catalyst and solvent as well as the total consumptions and the emissions of Volatile Organic Compounds (VOC) during the operation of the machine (production mode only).

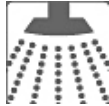
On the box of the machine, a seal gland enables an electrical supply to the machine with electricity via a safety isolating switch (115V / 230V).

The pictograms located under the screen allow the user to remember easily the various functions managed by the PU 3000.

Pictogram	Mode	
	Production	<b>F1</b>
	Flushing	<b>F2</b>
	Parameters	<b>F3</b>
	Consumptions / Print	<b>F4</b>
	Feeding of the pumps	<b>F5</b>

### 3. OPERATING DESCRIPTION

The 2 BASE and CATALYST materials are sent to the mixing machine from 2 pumps.

In production, as well as in regeneration, the machine injects a small volume of catalyst (P-6) in the base continuous flow.

The PLC continuously checks the mixing ratio and if it notices a fault that it cannot correct, an alarm is activated. The machine goes into safety mode.

The capacity of the pumps is configured (for the BASE pump : P4 parameter, for the CATA pump : P5 parameter) depending upon the equipment versions.

### 4. FEATURES

<p>Number of colors : 1          Number of catalyst : 1          Solvent and water-based paints compatibility          Control via a magnet in the control box          Continuous mixing check          Adjustable threshold alarm          Adjustable pot-life indicator          Automatic flushing cycle (time)          VOC display          Consumptions' total indicator : base, cata, solvent, VOC          Printing (connection to a printer or to a computer)</p>	<p>Voltage : 230V / 115V - 10W          Air pressure: Mini 4 bar / 58 psi - Maxi 6 bar / 87 psi          Dew point = + 3°C / 37°F          Filtration 5µm          Operating pressure :          from 0-6 bar / 0-87 psi or from 6-40 bar / 87-580 psi for the pneumatic version          from 30 to 180 bar / from 436 to 2610 psi for the Airmix® version          from 60 to 350 bar / from 870 to 5076 psi for the Airless version          from 30 to 180 bar / from 436 to 2610 psi for the 4 L 30/1 version          from 60 to 350 bar / from 870 to 5076 psi for the 4 L 53/1 version          Adjustable mixing ratio : from 0.6/1 to 20/1 (BASE volume / CATALYST volume) (from 160% to 5%)          Mixing precision : ± 1 %          Répeatability : ± 1 %          Mixed fluid output : refer to § 12 &amp; 13          Maximum operating temperature : 50°C / 122°F</p>
<p>Weight : 115 kg / 253.5 lb (Pneumatic version)          187 kg / 412 lb (Airmix® version)          217 kg / 478.5 lb (Airless version)          170 kg / 375 lb (4 L 30/1 version)          210 kg / 463 lb (4 L 53/1 version)</p> <p>Dimensions :</p> <ul style="list-style-type: none"> <li>- Control box : 355 mm x 275 mm x 135 mm</li> <li>- Fluid frame :</li> <ul style="list-style-type: none"> <li>860 mm x 670 mm x 1280 mm (pneumatic version)</li> <li>860 mm x 670 mm x 1270 mm (Airmix® version)</li> <li>960 mm x 670 mm x 1400 mm (Airless version)</li> <li>960 mm x 670 mm x 1405 mm (4 L 30/1 version)</li> <li>960 mm x 670 mm x 1435 mm (4 L 53/1 version)</li> </ul> </ul>	<p><b>Connections :</b></p> <ul style="list-style-type: none"> <li>Air inlet : F 3/4 BSP (air inlet valve)</li> <li>Fluid outlet (mixer) :</li> <ul style="list-style-type: none"> <li>F 3/4 JIC or assembly of a fitting (→ M 1/2 JIC)</li> </ul> </ul>

## 5. INSTALLATION

### ■ HANDLING

The PU 3000 system with relevant weight and dimensions must be handled by appropriate means.

Nota : The handling of the machine must be carried out by a qualified staff, in an appropriate space, correctly cleared to avoid any risks of fall or of crushing of people.



**Nota : The ring located above the cover is for the hoisting of the pump and shall not be used for the handling of the complete machine.**

The frame has 4 holes ( $\varnothing$  9) to be fixed on a bracket or on the floor.

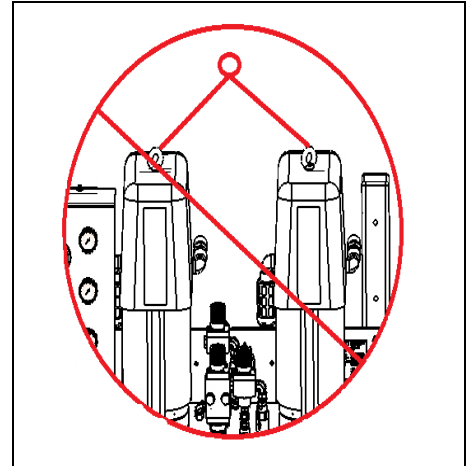

### ■ STORAGE

Storage before installation :

- Storage ambient temperature : 0 / + 50 °C. / 32 / +122° F
- Protect the equipment against dust, running water, dampness and shocks.

Storage after installation :

- Operating temperature : + 15 / + 35 °C. / + 52 / + 95° F
- Protect the equipment against dust, running water, dampness and shocks.

### ■ ENVIRONMENT ON THE AREA



The unit must be installed on a horizontal stable floor (eg : flagstone).

**Ensure the machine is stable.**

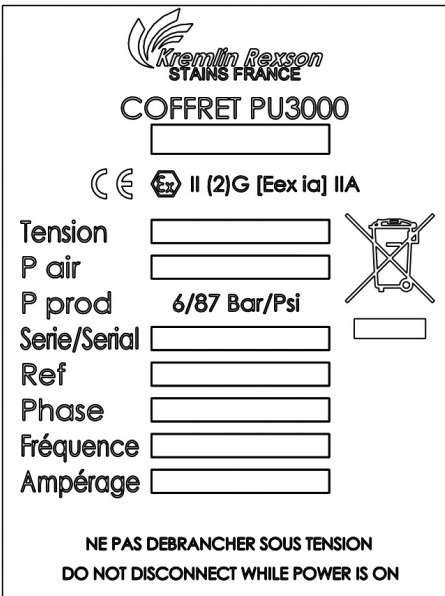

The working area must be correctly ventilated.

■ **DESCRIPTION OF THE LABEL MARKINGS**

The PU 3000 machine is fitted with 2 label markings : a plate on the control box and another one on the fluid equipment.

 <p><b>Marking label on the control box</b> (box located <u>outside</u> the spray booth)</p>	 <p><b>Marking label on the fluid module</b> (fluid module assembly can be located inside the spray booth → marking in accordance with the ATEX directive)</p>
---	--

**Marking according to the ATEX Directive**

<b>KREMLIN REXSON STAINS FRANCE</b>	Name and address of the manufacturer
<b>CONTROL BOX :</b> CE  II (2) G [EEx ia] II A	<b>II</b> : group II <b>(2)</b> : Control box contains components ensuring the safety of the class 2 fluid module. <b>G</b> : gas <b>[EEx ia]</b> : Control box contains SI ia barriers. <b>IIA</b> : Gas group for the equipment category
<b>FLUID MODULE :</b> CE  II 2 G IIA T3	<b>II</b> : group II <b>2</b> : class 2 Surface equipment meant to area where explosive atmospheres due to gas, vapours, mists are liable to appear from time to time in usual operating <b>G</b> : gas <b>IIA</b> : Gas group for the equipment category <b>T3</b> : Maximum surface temperature : 200°C / 392°F
<b>P air</b>	Maximum air pressure
<b>P prod 6/87 Bar/Psi</b>	Maximum fluid pressure
<b>Série / Serial</b>	Number given by KREMLIN REXSON. The two first numbers indicate the manufacturing year.
<b>Ref</b>	Part number of the PU 3000 machine
<b>Phase</b>	Single phase
<b>Fréquence</b>	50-60Hz / Mains frequency
<b>Ampérage</b>	Maximum current used

■ INSTALLATION DIAGRAM

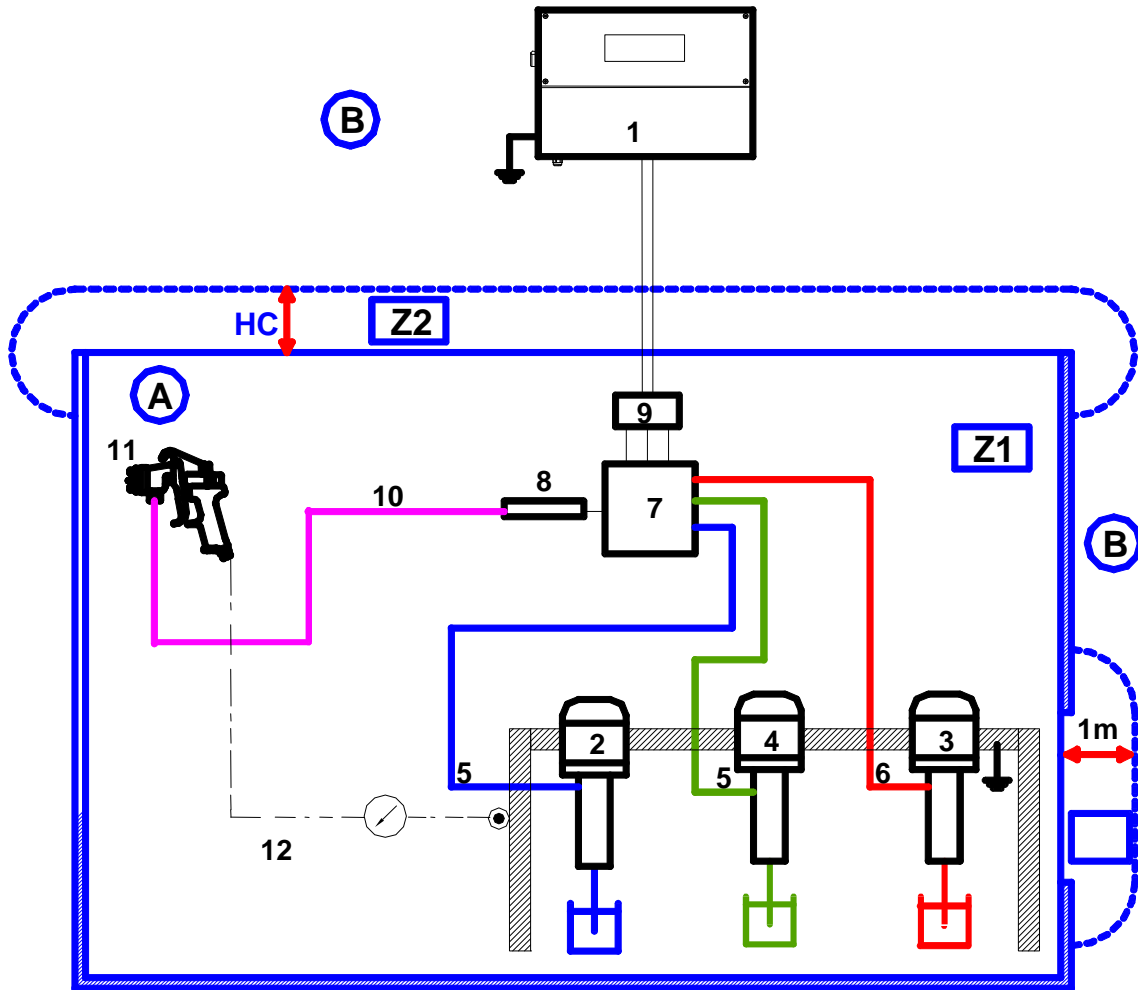

A	Potentially explosive area : area 1 (Z1) or area 2 (Z2) (spray booth)	6	PTFE HP fluid hose
B	Non explosive area (safe area)	7	Automatic valves
1	PU 3000 control box	8	Mixer
2	BASE pump	9	Electrovalves
3	CATALYST pump	10	HP Fluid hose (not supplied)
4	Flushing pump (option)	11	Gun (not supplied)
5	HP fluid hose	12	Gun spraying air from the machine



The 1 m / 39.37" distance indicated in these diagrams is given for information only and holds harmless KREMLIN REXSON. The user is liable for the exact delimitation of the areas which depends on the material used, the material environment and on the use conditions (refer to EN 60079-10 standard). The 1 m / 39.37" distance could be modified if analysis carried out by the user deems it necessary.





- The control box must be connected to a supply fitted with a ground. The bracket of the pumps is fitted with a ground cable. That must be grounded.
- Do not install the paint drums underneath the pumps or the electric equipment. Place them in front of the frame. Install a cover on the drums to reduce the diffusion of gas and vapours in the booth.
- The electrical cable connecting the chassis mounted electric components to the control box must be installed so that at no time is any risk from mechanical damage, chemical corrosion or excessive heat. Please ensure that the wiring loom is kept separate from any other electrical cables that are not intrinsically safe.

## ■ INSTALLATION

There are different ways to install the PU 3000 to answer to the majority of the installations.



The control box of the PU 3000 mixing machine must be installed outside the spray booth in a safe area.

### Assembly for piloting outside the booth :

The machine is in two parts to enable the control box to be fitted outside the booth (cable of 8 m / 26.2 ft between the 2 elements).

*Nota : Drawing of a unit, model PU 3000 Airmix®*

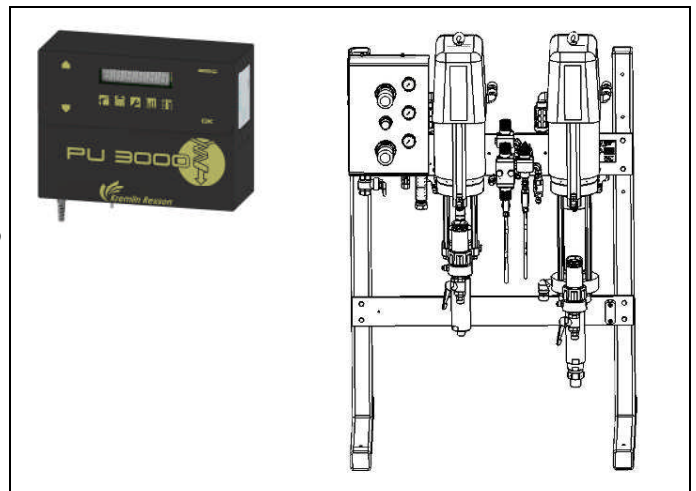

### Assembly for machine control in the booth :

There is a booth mounting control kit (available in option).

That kit enables the user to fix the control box on the booth by means of a glass panel and to control the machine inside the spraybooth.

The control is carried out thanks to a magnet provided with the machine. The distance between the control box and the fluid frame is of 8 m / 26.2 ft (cable supplied with the machine).

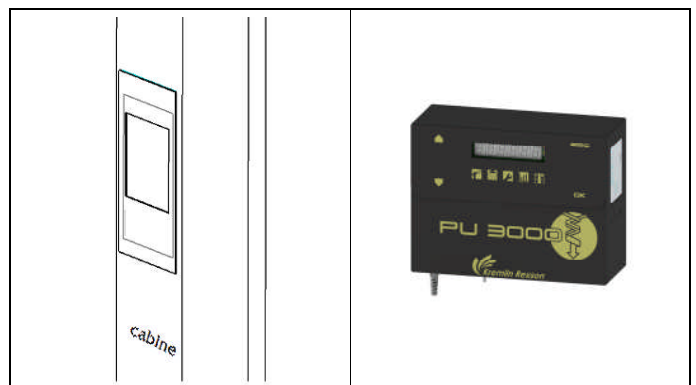

■ CONNECTION OF THE CONTROL BOX AND OF THE FLUID FRAME

➡ The PU 3000 must be connected to a dry and clean compressed air network (minimum 4 bar / 58 psi) and to a single phase electric supply (115V / 230V) connected to an isolating switch. The electric supply must have an appropriate protection (30 mA). The network ground will be connected in the control box on a connect provided and identified with the

symbol .

 **Before connecting the PU 3000, be certain the mains voltage is the same as the one of the machine (230 V).**

If no, open the electric box removing the protective housing and move the jumper (230V → 115V).

The machines with a stabilized electric supply tolerate all voltage types (115V / 230V).

Connect the air equipment of the PU 3000 to the pneumatic network with a conductive hose (minimum 16 mm / 5/8 dia).

**Nota : these hoses are not supplied in the standard version.**

The air connection of the machine is Female 3/4 BSP (air inlet valve).

The connection between the control box and the electrovalves located on the frame, is carried out via cable, length : 8 m / 26.2".

Between the mixer outlet and the spray gun, you must install a fluid hose, model HP (high pressure) ( act according to the pressures the pumps supply).

**Fuse 160 mA  
for machine with serial number < to 09Y1080**

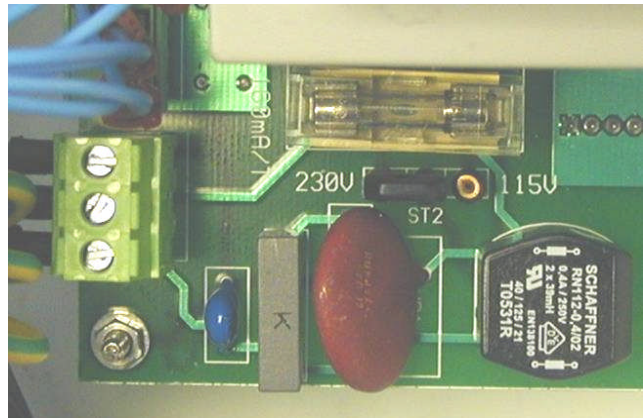

**Fuse 315 mA  
for machine with serial number >to 09Y1080**

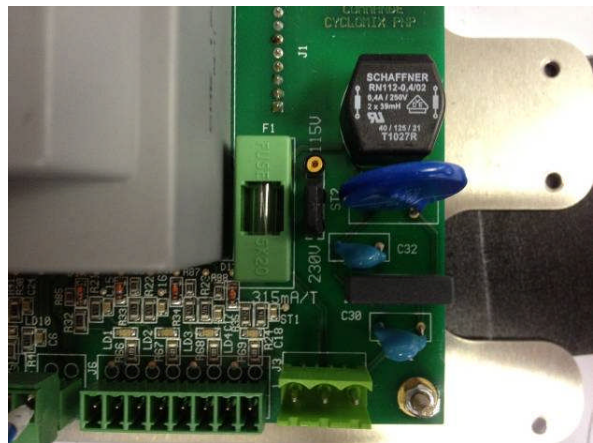

**Machine with a stabilized electric supply**

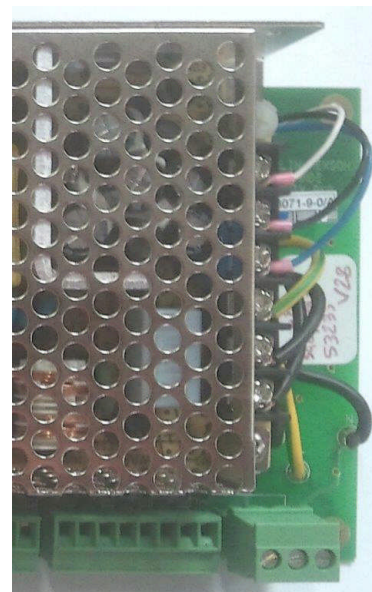

## 6. OPERATING

### ■ DRIVING FROM THE MACHINE

#### SCREEN

Different menus and information relating to the machine are displayed on the alphanumeric screen.

#### KEYBOARD

ESC	That key enables the user to quit the menus or the different modes (production, flushing, parameters).
OK	That key enables the user to enter in the different menus or to validate a value of parameter.
▲	That key enables the user to shift from a menu to another and to increase the value of a parameter during modifications of value.
▼	That key enables the user to shift from a menu to another and to decrease the value of a parameter during modifications of value.

The keyboard is controlled thanks to a magnet provided with the machine. That control mode enables the user to drive the machine inside the booth if the box is installed behind the booth glass panel. This technology enables the operator to save time and to carry out his work from the place application.

### ■ SWITCHING ON THE MACHINE



**The placing of the system into operation requires that the BASE, CATALYST and SOLVENT drums are full enough to ensure the production.**

**Connect the gun before placing the system into operation.**

Unscrew the 3 air regulators before supplying air to the installation.

Supply air to the PU 3000 (minimum 4 bar / 58 psi).

Switch on the control box (switch located on the side of the box).

When switching on the control box, a menu is displayed on the screen.

*Nota : Parameters have been set up in the factory before the delivery of the machine. You must adapt the parameters to the use. They must be modified by an authorized person (refer to list of parameters).*

## 7. FIRST SWITCHING ON

### STANDARD MENU

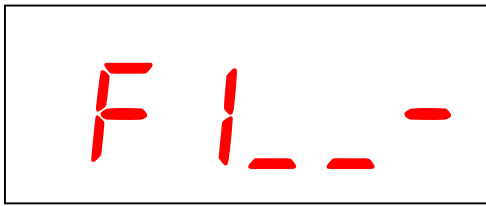

Countdown on fluid life time.  
(countdown from 9 to 0; 9 represents 90% of the remaining time before the regeneration).

A line is visible when the PU 3000 is flushed.

When switching on, the machine is waiting. The 'F1' menu corresponds to the shift to the production mode. There are five different menus : they enable to control the PU 3000.

- F1 : production
- F2 : flushing
- F3 : parameters
- F4 : consumptions
- F5 : feeding of the pumps

To surf from a menu to another, you must move placing the magnet on the sensors indicated with '▲/▼'.  
The menus scroll as follows :

### Arborescence of the menus :

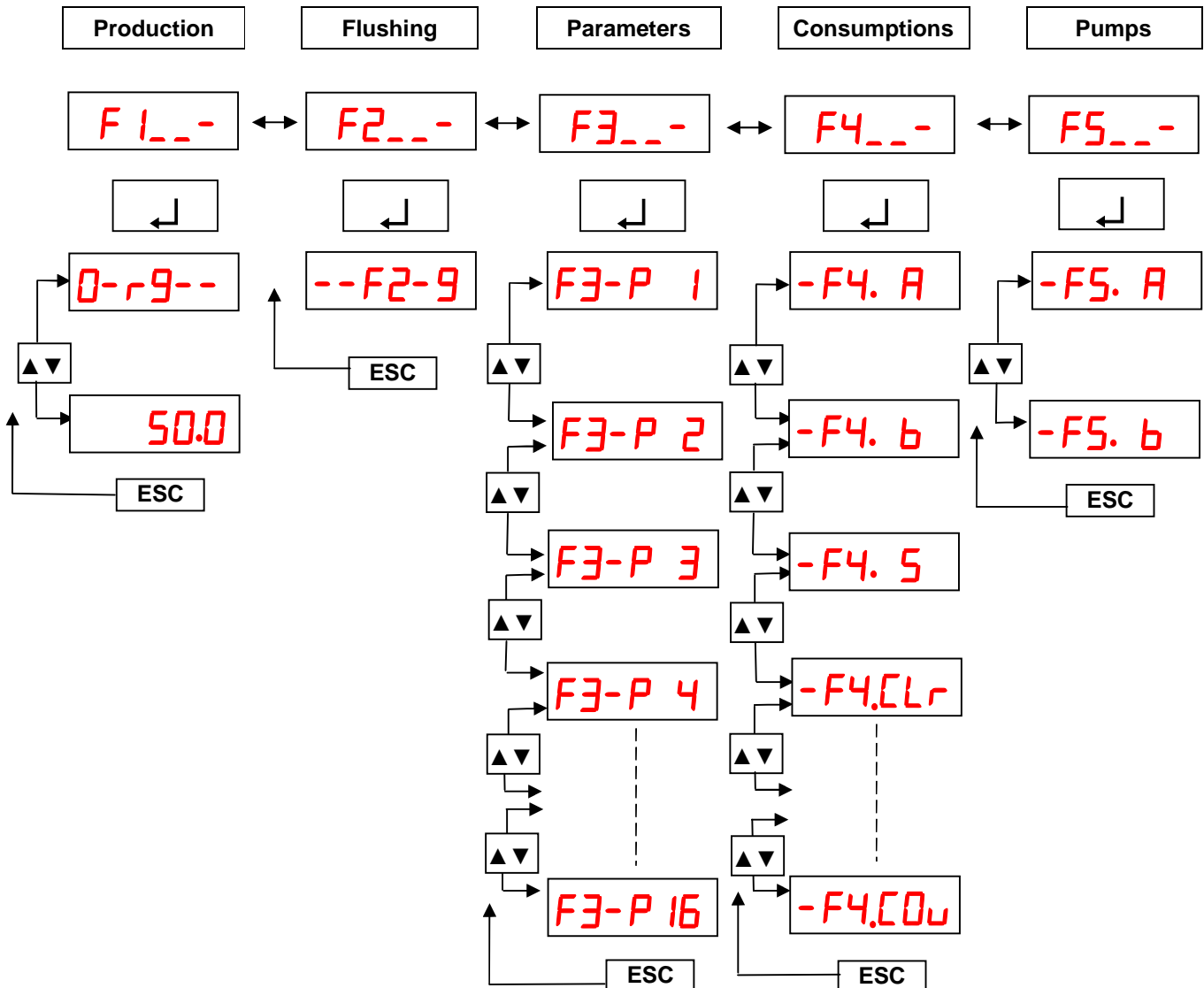

## 8. FIRST PLACING INTO OPERATION

### ■ BEFORE SWITCHING ON

Before switching on, half fill the cups with T lubricant or with the appropriate solvent (only for standard fluid sections, not for Flowmax® fluid sections).

*Nota : the cup nut must be slightly tightened with the wrench provided. Too much tightening may damage the cup seals.*

#### Tightening of the wetting cup :

- Fill the cup with T lubricant,
- Start the pump, then tighten the cup after 10 minutes, then 1 hour, then 1 day of operating,
- If you notice any leakage, the cup must be tightened.

*Nota : Stop the machine and depressurize the air and fluid networks to tighten the cup.*

### ■ FLUSHING OF THE PUMPS AND OF THE MACHINE IN SOLVENT



**During that first placing into operation, it is compulsory to have all the pumps into solvent as well as the machine to ensure the good quality of the fluid get by the PU 3000.**

**The fluid pressure must not exceed 1 bar / 14.5 psi on the gauges.**

- Carry out the connections indicated at § 5 (INSTALLATION),
- Immerse the suction rod of the BASE pump in the solvent container,
- Close the gun air supply valve,
- On the page of the display main menu, enter 'NORMAL OPERATING' (F5 then **OK**), then select the A pump (▲ or ▼, and **OK**),
- Trigger the gun to start the A pump with solvent and increase the fluid pressure to at least 1 bar / 14.5 psi (reading on the gauge) or go through the drain valves,
- Release the gun trigger when there are no more air bubbles in the solvent at the gun nozzle,
- Immerse the suction rod of the CATALYST pump in a solvent container,
- On the page of the display main menu, enter 'NORMAL OPERATING' (F5 then **OK**), then select the B pump (▲ or ▼, and **OK**),
- Trigger the gun to start the B pump with solvent and increase the fluid pressure to at least 1 bar / 14.5 psi (reading on the gauge) or go through the drain valve,
- Release the gun trigger when there are no more air bubbles in the solvent at the gun nozzle,
- Turn the air valve that supplies air to the flushing pump,
- On the page of the display main menu, enter 'FLUSHING MODE' (F2 then **OK**),
- Trigger the gun to prime the SA pump with solvent and increase the fluid pressure to at least 1 bar / 14.5 psi (reading on the gauge),
- Release the gun trigger when there are no more air bubbles in the solvent at the gun nozzle,
- Do not modify the factory parameters for the moment.



**Caution : Do not supply gun with atomising air to prevent any atomisation and point the solvent fan into a container.  
We advise you to wear protective glasses and gloves.**

- Go out from the 'NORMAL OPERATING' mode passing to ESC.
- Close the air supply valve of the flushing pump.

## ■ START UP OF THE MACHINE

- Take off the BASE and CATALYST suction rods from the solvent containers and introduce them in their respective container.

**⚠ Caution : never invert the suction rods.**

- Open the drain valves located at the outlet of the fluid sections. Start up the pumps. Prime the pumps, then close the drain valves.
- Pass to production mode and let the fluid flow until it flows clean. In case of alarm, disable then go to production mode.

**CAUTION : do not supply atomising air to the gun.**

- Carry out a flushing to clean the mixed circuit. As soon as the solvent is clean, pass to ESC.

The parameters are preset up in the factory. You can change them (refer to § 9).

## ■ MIXING RATIO CHECKING

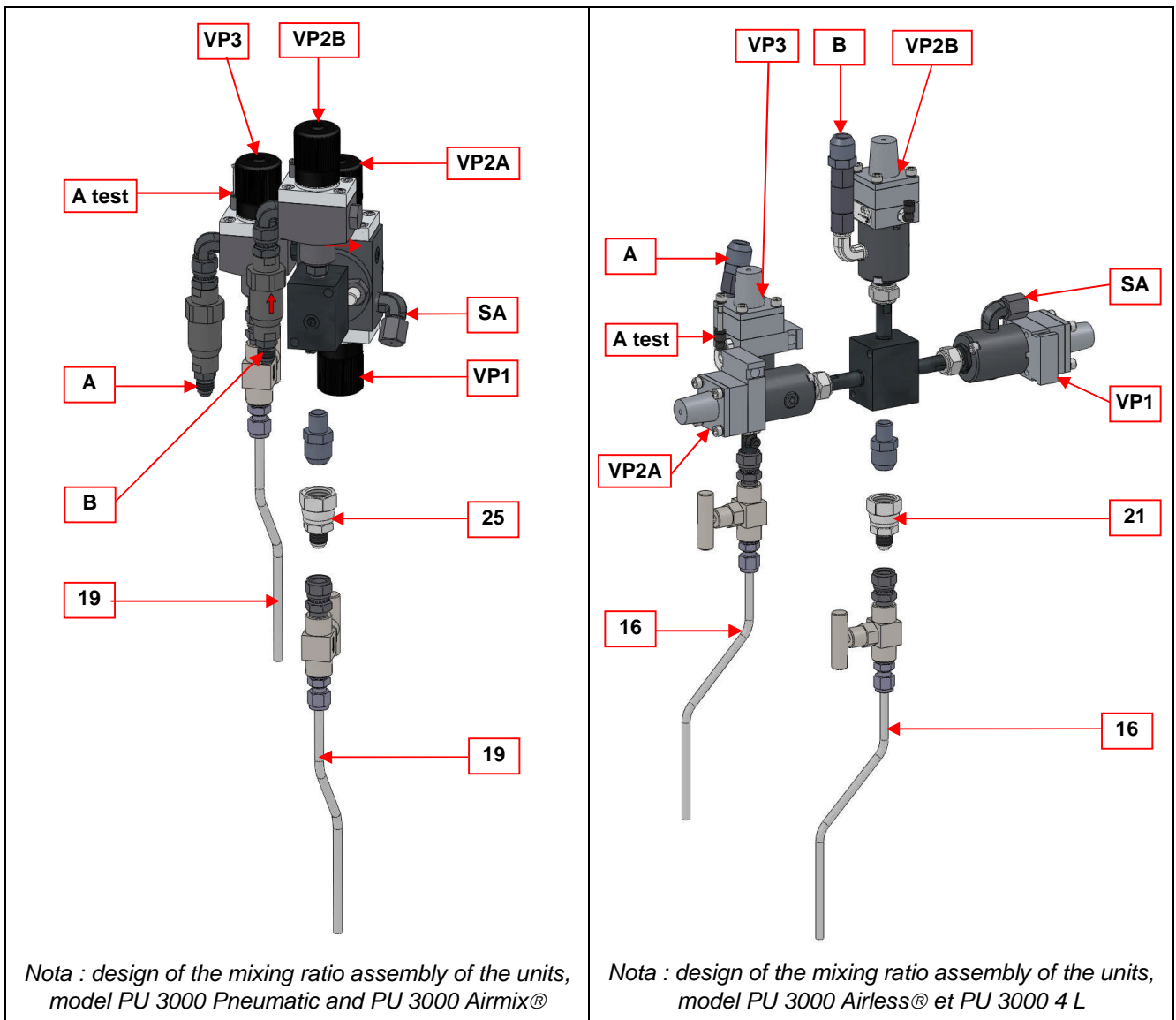

Switch off the unit.

Remove the 'mixed fluid' hose located on the outlet of the mixing unit. Install, instead of it, the fitting (21 or 25) and the needle-valve assembly (16 or 19) supplied with the machine.

Take off the control air hose on the VP2A BASE valve.

Connect that hose to the VP3 valve. The VP3 valve is originally supplied with a needle valve assembly (16 or 19).

Switch on the unit.

Pass in **F 5** mode to adjust the opening of the needle-valves.

**-F5 A**

Prime the A pump and adjust the opening of the needle-valve.

**-F5 b**

Prime the B pump and adjust the opening of the needle-valve.

Place the beakers underneath the valves.

Input **-F3 P 16**

The PU 3000 passes in test mode and displays

**t 50.0**

 **Caution : the fluid pressure must be lower than 200 bar / 2900.6 psi.**

The BASE and CATA materials are dispensed into the beakers. After a while, close the needles' valves and check the ratio.



Activate ESC to stop the test and only after that you can removing the test outlet.

Nota : During that stage, you can not use the spray gun.

 **When the mixing ratio checking is over, switch off the PU 3000 machine.**

Disconnect the air hose from the VP3 valve and connect it to the VP2A BASE valve.

Remove the needle-valve assembly (16 or 19) and the fitting (21 or 25). Screw again the fluid hose on the fitting (M 3/4 JIC) at the outlet of the mixer unit. Start up the machine : enter 'PRODUCTION MODE' (F1 then **OK**).

-  **Wear protective glasses to protect the eyes from possible discharges during the handling of the valves.**
-  **Flush the needle valve assembly that has been removed and do not leave the catalyst crystallize : - Flush the CATA test outlet : input F2 to carry out the flushing. When it is clean, activate ESC.**
  - Flush the BASE test outlet : invert the test outlets and carry out a flushing until it is clean.

## 9. APPLICATION PROGRAMMING (F3)

To alter the parameters of the PU 3000, go to F3, then validate. To shift from a parameter to another, use the arrows ▲ or ▼.

Select the parameter to alter. Depress the key **OK**, then the arrows ▲ or ▼ to increase or decrease the value. Activate **OK** to validate the new value or ESC to cancel.

To quit a parameter, activate **ESC**.

To quit the PARAMETERS menu, activate **ESC**.

The parameters are pre-set up in the factory. They must be adjusted (by an authorized person) to suit the material to be processed.





The calibration of the stroke length is carried out in the factory. When removing the movement sensors or when disassembling the fluid section from the motor, it is important to initialize the pumps (refer to Validation of the initialization mode, page 23).

### ■ PASSWORD

When you start the machine for the first time the access code of the menu 'Parameters' is deactivated, everyone is able to modify the machine's parameters.

To activate this access code you have to :

- enter in the parameter 0 of the menu F3: **F3--** → «key » → **P -- 0** → «key ».  
The code '0000' appears, it's the code present by default in the machine.

- change the code by using the arrows ▲ or ▼ and the «key » for each digit which compose this code.

Once the access code was validated, the access is protected by the password. Only the people who know this password and those which know the administrator code '5555' will be able to reach the menu 'Parameters'.

Each time a user wants to enter in the menu 'Parameters' the password will be required: **[ 0---**.

The user shall enter the password by using the arrows ▲ or ▼ and the «key » for each digit which compose this code :

- If the entered code is correct, the following fonts **-----** appear.

- If the entered code is incorrect, the word '**Error**' appears and the machine allows you to enter the password again (Press 'Esc' to return to the principal menu).

If you want to deactivate the password, you just have to parameterise the code '0000' again as access code.

### ■ PROCEDURE TO GET THE VERSION NUMBER OF THE ELECTRONIC CARD

- Switch off the unit.
- Input **OK**.
- Switch on the control box : The version number is displayed.
- Release **OK** to start the machine out.



■ PARAMETERS

Parameters	Description	Factory adjustment	Your adjustments
F3- -P0	Parameter of the password	0000	
F3- -P1	Mixing ratio parameter. Percentage of catalyst in the base, from 0,1% to 160%	50 %	
F3- -P2	Parameters of the mixed fluid life time Minimum value : 1min Maximum value : 999 min	30 min	
F3- -P3	Regeneration volume parameter in cubic centimetre Minimum value : 1 c.c Maximum value : 9 999 cc	200 cc	
F3- -P4	Section of the A piston Minimum value: 1 mm2 Maximum value : 99 999 mm2	For fluid section - 50 : 465 (airmix® version), 485 (pneumatic version) For fluid section - 50cc : 555 (airless version) For fluid section - 225cc : 1010 (4 L 30/1 version) For fluid section - 227cc 1025 (4 L 53/1 version)	
F3- -P5	Section of the B piston Minimum value: 1 mm2 Maximum value : 99 999 mm2	For fluid section - 50 F : 470 (airmix® version), 490 (pneumatic version) For fluid section - 50cc : 555 (airless version) For fluid section - 225cc 1010 (4 L 30/1 version) For fluid section - 227cc 1025 (4 L 53/1 version)	
F3- -P6	Injection volume Minimum value : 0,1 cc Maximum value : 999,9 cc	4,8 cc	
F3- -P7	Mixing tolerance Minimum value : 0,1 % Maximum value : 100 %	3 %	
F3- -P8	Alarm volume for the A pump Minimum value : 1 L Maximum value : 40 000 L 0 : parameter not taken into account OK : reset of low level pump shut off –A-	0	
F3- -P9	Alarm volume for the B pump Minimum value : 1 L Maximum value : 40 000 L 0 : parameter not taken into account OK : reset of low level pump shut off –B-	0	
F3- -P10	Initialization mode (values of the high and low thresholds of the movement sensors) OK : to activate that mode		

Parameters	Description	Factory adjustment	Your adjustments
F3- -P 11	Flushing time Minimum value : 10 seconds Maximum value : 500 seconds	120 s	
F3- -P 12	Flushing volume Minimum value : 10 cc Maximum value : 5000 cc	500 cc	
F3- -P 13	Number of thousands of cycles before preventive maintenance on the A pump Minimum value : 1 Maximum value : 9999	500 cyc (i.e. 500 000 cycles)	
F3- -P 14	Number of thousands of cycles before preventive maintenance on the B pump Minimum value : 1 Maximum value : 9999	500 cyc (i.e. 500 000 cycles)	
F3- -P 15	Percentage of dry extract in the base Minimum value : 0 % Maximum value : 100 %	50 %	
F3- -P 16	Ratio Test mode <b>OK</b> : to activate that mode		

#### ■ VALIDATION OF THE INITIALIZATION MODE

That mode enables the machine to define the high and low settings of the movement sensor on each pump.

After validating the **F3- -P 10** parameter, the machine displays **A1**, and controls the down stroke on the BASE pump piston : open the gun or the BASE drain valve to make the piston go down.

Once the BASE pump piston is in low position, close immediately the valve or the gun avoid the decompression of the circuit, then input **OK**.

Then, the piston displays **A2**, it goes up and is waiting for the high setting of the BASE pump. Open the gun or the BASE drain valve to make the piston go up.

Input **OK**.

The machine displays **b1**, and controls the down stroke of the CATA pump piston : open the gun or the CATA drain valve to make the piston go down.

Once the CATA pump piston is in low point, close immediately the valve or the gun avoid the decompression of the circuit, then input **OK**.

Then, the piston displays **b2**, it goes up and is waiting for the high setting of the CATA pump : open the gun or the CATA drain valve to make the piston go up. When the piston is up, close immediately the circuit to avoid the decompression.

Input **OK**.

After that last validation, the machine comes back to the parameter **F3- -P 10** menu.



**Caution : that parameter must be modified only when changing the sensor (disassembly or re-cabling) or when updating the software or or of the electronic card or when changing a barrier Zener (CA and CB only). If the procedure is launched, it must be carried out in entirety, if not : the machine will not work correctly any more.**

## ■ PRODUCTION (F1)



The CATALYST pressure must always be higher by 5 to 10% than the BASE pressure.



Real mixing ratio

If the machine is in mixed material, open the gun spraying air supply valve.  
Trigger the gun.  
Adjust the spraying air regulator to get the desired fan.



If the machine is not in mixed material, a regeneration is automatically carried out to bring the mixed material to the gun.

We advise you to shut off air during that stage.

When passing to production for the first time, the machine carries out a regeneration.



The display consists of a countdown that enables to know, in percentage (9 → between 90% and 100% of the volume), the volume remaining to be dispensed according to the P3 parameter. At the end of that stage, the machine enters in production. You can also activate **ESC** during the fluid priming; we advise you not to start painting immediately.

In production, there are 3 main screen messages:

- The operator is spraying and the PU 3000 is operating correctly. The real mixing ratio is displayed on the screen.

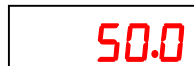

- The machine stops because of a malfunction. The kind of breakdown is displayed on the screen, the machine emits an alarm signal to inform the operator (cf § 'TROUBLESHOOTINGS').

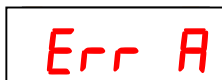

- The machine has reached the maximum life duration of the material and passes automatically in regeneration mode. The machine emits an alarm signal to inform the operator. The following screen is displayed :

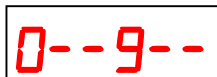

Open the gun until the regeneration ends (shut off spraying air), then the machine passes to production.



You can stop the regeneration by activating **ESC**. Then, the regeneration will stop, but be careful, the quality of the mixed material can be inferior.

To exit from production : activate **ESC**.

*Nota : We recomend to keep the nozzle on the gun during the color priming / regeneration.*

■ **FLUSHING (F2)**

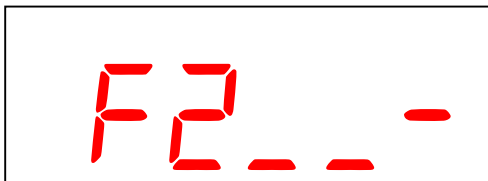

This menu is used for flushing. When you want to flush the machine, activate **OK** when you are on the F2 menu.

After confirming via **OK**, the machine opens the solvent valve. The buzzer sounds intermittently. Check the solvent pump supply valve is open.

A countdown begins : [F2-9], then [F2-8].

The machine stops when the countdown is over.

The machine closes the solvent valve and the mixed material flushing has ended.

*Nota : Close the spraying air valve during the 'FLUSHING' stage.*

*During the first flushing, you can determine the solvent volume (F3 P12 parameter) consumed during the flushing time (F3 P11 parameter). Once determined, enter your parameters accordingly.*

■ **CONSUMPTIONS / PRINT (F4)**

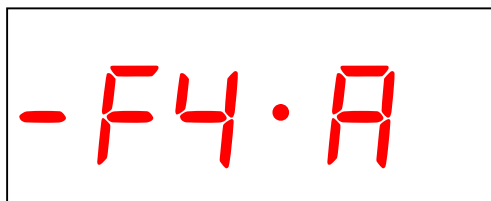

The 'F-4' menu enables to view the consumptions of each material (color, catalyst in L). You can also print the ratio of the consumptions as well as the parameters of the applications : you must connect a connection cable to a printer or to a computer (RS 232 connection) (printer not provided) (refer to Downloading data from PU3000 to a computer page 27).

	Consumption of the base		Consumption of the VOC
	Consumption of the catalyst		Enables the user to reset the consumptions activating the key <b>OK</b> thanks to a sub menu
	Consumption of solvent		Enables the user to print the consumptions and the parameters activating the key <b>OK</b>

**Arborescence of the F4.Clr menu :**

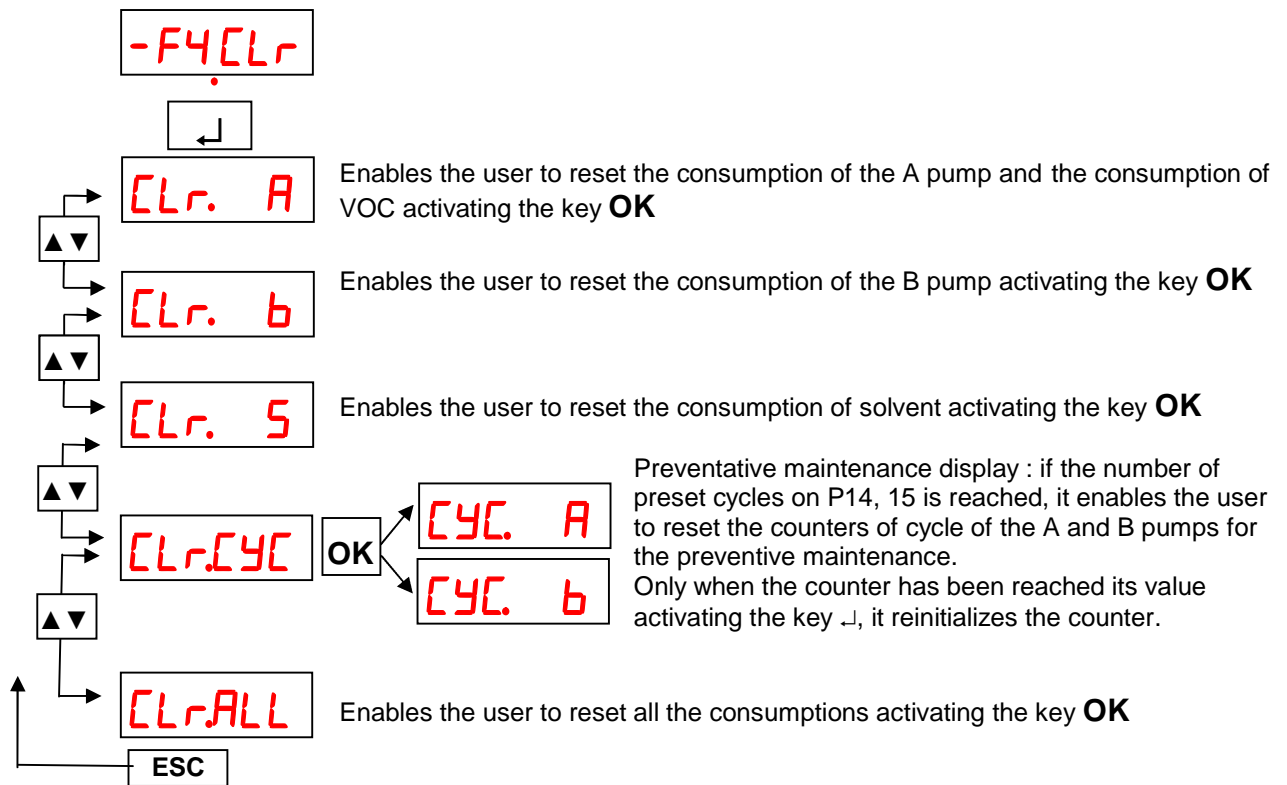

## ■ DOWNLOADING DATA FROM PU 3000 TO A COMPUTER

### Preamble / "Hyper Terminal" issue

This application is necessary. Two cases are to be considered :

.PC under Windows XP/Vista/2000,

.PC under Windows 7.

- **With Windows XP/Vista/2000**, "HyperTerminal" application is available with the following path :  
Menu Start > All programs > Accessories > Communications > HyperTerminal

- **With Windows7**, you will need to download freeware "HyperTerminal" from some website.

For example : <http://www.01net.com/telecharger/windows/Bureautique/telephonie/fiches/5829.html>

Once it is downloaded and installed, carry out a simple test of opening and closing.

It should look like this whenever open :

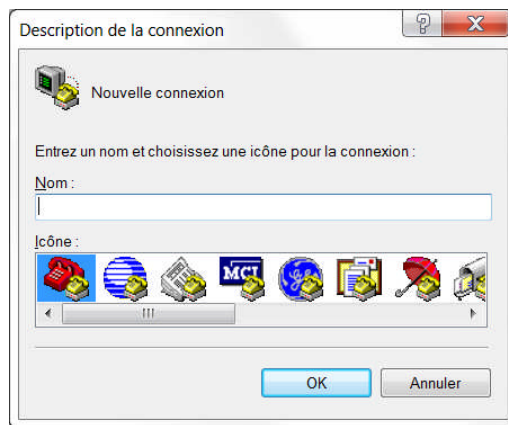

### Switching of the control box

- Switch the control box.
- Link a "RS232 male / USB male" cable to the plug located below the Micro back frame, the other end to the USB plugs on the computer. Cable not supplied by KR.



- According to the USB plug used a "port com" number appears in the "device manager" screen (Menu Start > Control panel > Device manager).

- After deployment of the "Ports" line, one of them indicates the cable pilot name ("Prolific USB" for example or else), followed by the "port com" number (COM5 in that display).

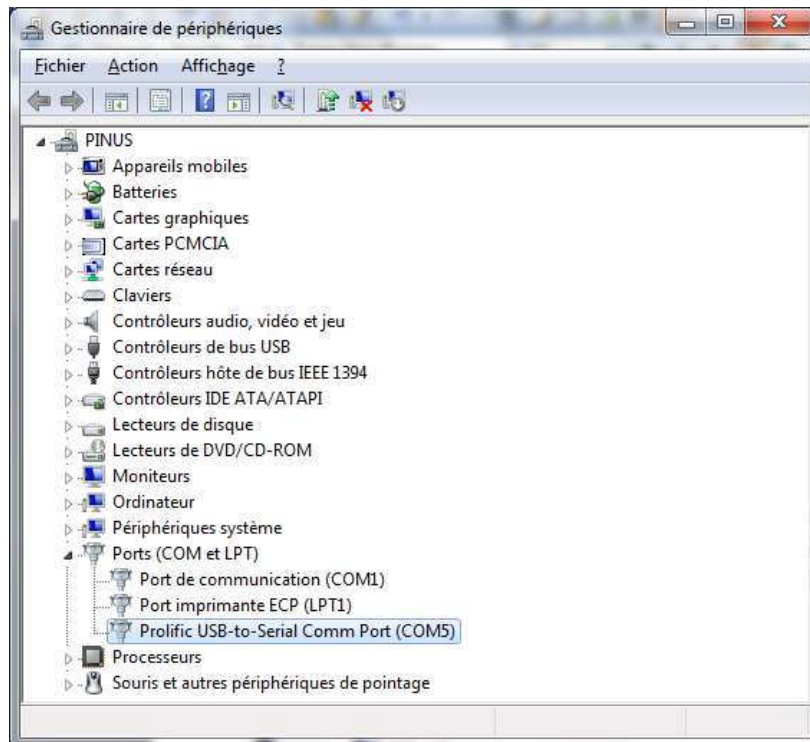

- Open "HyperTerminal" window.
- At the first connection, create a new connecting session, write a name in (order number or paint reference) by choosing the first left icon. Press OK.

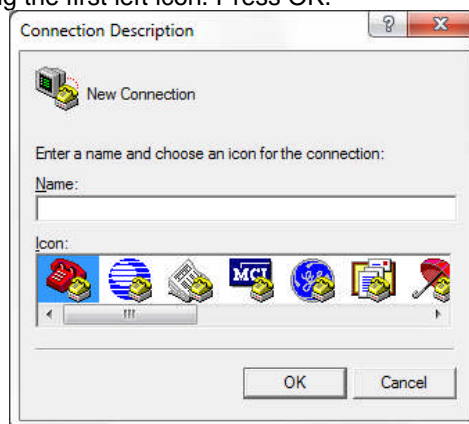

- This screen appears. Select the "port com" number previously noted during your connection. Press OK.

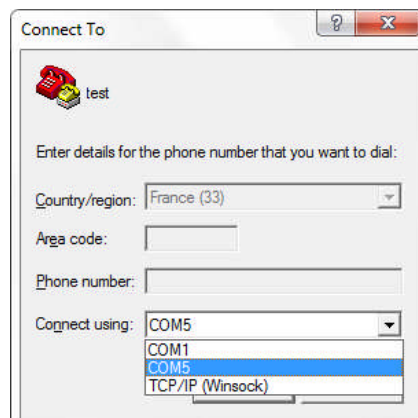

- That new screen will appears. Select band rate 9600 bits/s. Press OK.

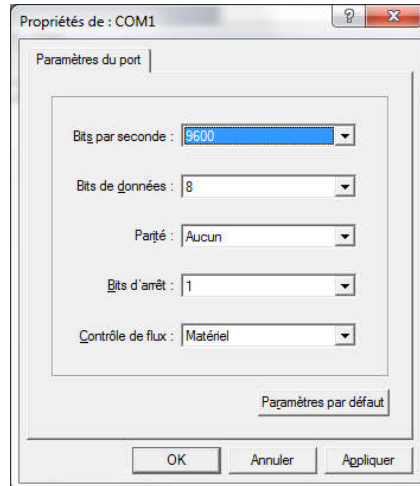

- A connection stopwatch gets activated. Leave the "Hyper Terminal" window open.
- If a session has already been created, opening the existing file is possible by going directly through the,  of the "HyperTerminal" menu, and by choosing it within the list of the \*.ht files. (ex : PU3000usb).
- Create a .txt file through "transfer" (transfer > capture text), choose some file name as target (ex : dataPU3000.txt), with a location within the PC disk, and press "START" (the empty file is created / leave the HyperTerminal window always open) :

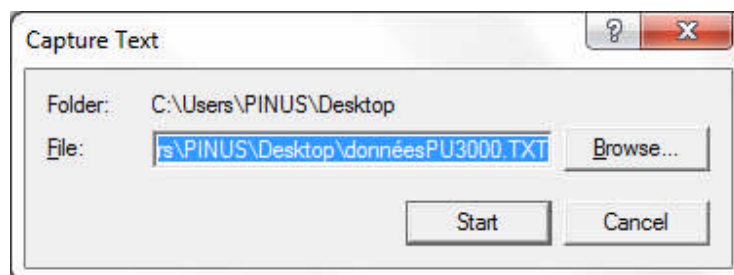
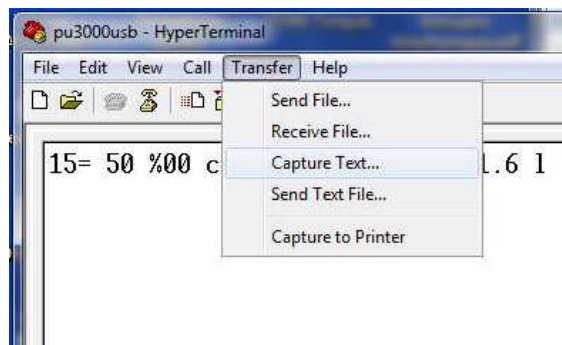



- Launch the data transfer from the control box (menu "F4. Prn" + OK), the data do appear (partially) in the display zone.

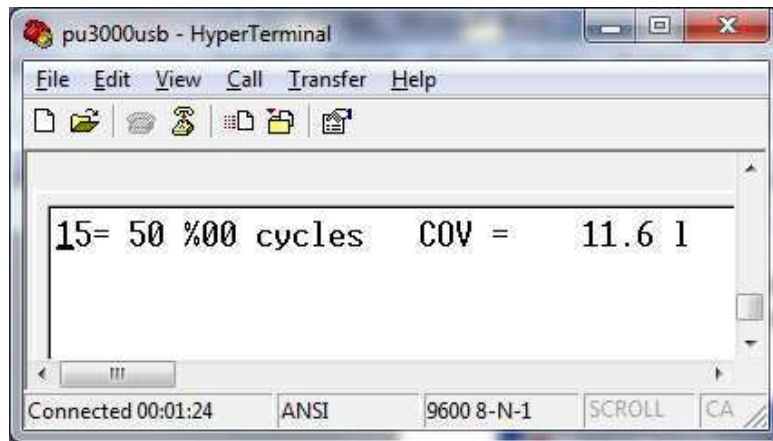

- Get back in the "transfer" menu (transfer > capture text) and press "Stop" :

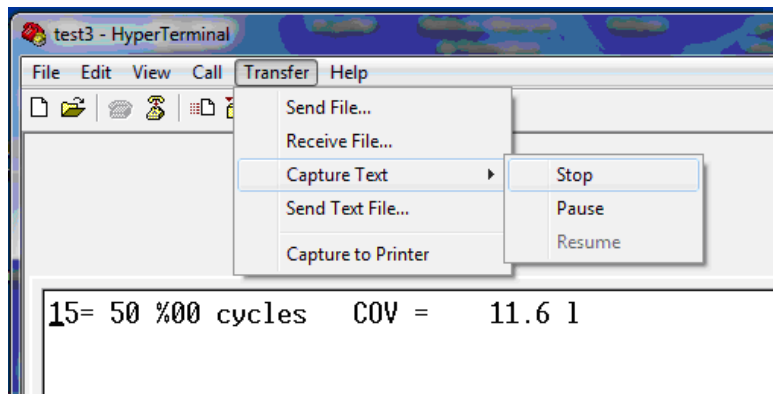

- Data then become available when opening the previous created .txt file.

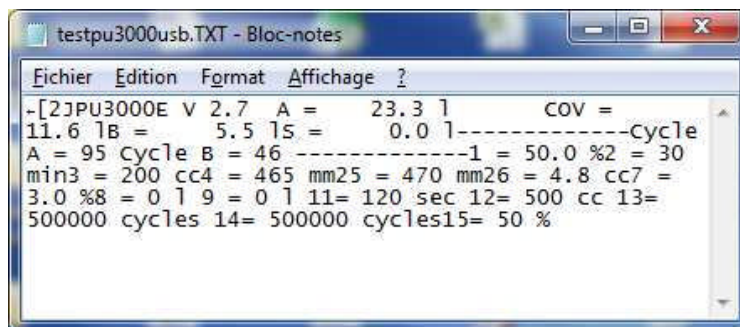

- From these displayed elements .txt (difficult to read up), make a simple "copy/paste" in an Excel file and data will appear as per that screen :

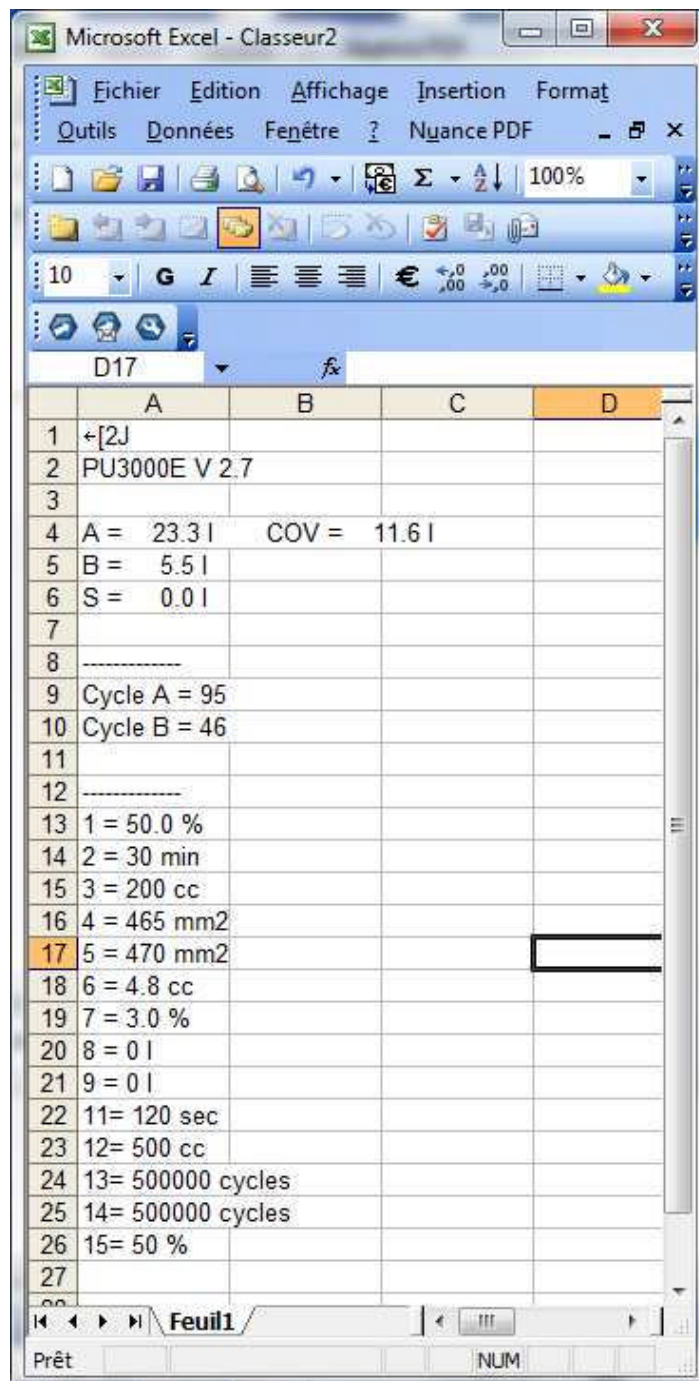

#### ■ DRUM REPLACEMENT PROCEDURE

When replacing the drum, you should prime the pump to avoid air bubbles.

*Nota : We recomend you to use a 6 L gravity cup (ref. 151140230) to feed the catalyst pump on a gravity mode to avoid air bubbles in the Flowmax pump.*

## 10. INDICATIONS OF OPERATION GIVEN BY THE MACHINE

### ■ INDICATIONS GIVEN BY THE LEDS

Description	Function	Action
Red LED	Fault	The machine stops
Orange LED	Working	Function other than production (flushing, pot-life alarm ...)
Green LED	Production	
Green + orange LED	Waiting	
LED switched off	Programming	

### ■ MESSAGES GIVEN BY THE DISPLAY UNIT

The messages given by the display unit are for your information only but do not stop the machine.

#### Number of cycles' overrun indication

Messages	Indications
Cyc.A	Overrun of the number of cycles configured at the P13 parameter
Cyc.b	Overrun of the number of cycles configured at the P14 parameter
Cyc.Ab	Overrun of the number of cycles configured at the P13 & P14 parameters

#### Fluids' consumption alarm

Messages	Indications
--A--	A fluid consumption alarm → A container empty (volume fixed by the P8 parameter) OK (during at least 3 seconds) : reset of low level pump shut off –A-
--b--	B fluid consumption alarm → B container empty (volume fixed by the P9 parameter) OK (during at least 3 seconds) : reset of low level pump shut off –B-

# 11. MAINTENANCE



Never leave mixed material in the machine. Properly adjust the potlife parameter to avoid curing. Carry out a flushing when the work is over.  
Flush when ending the work.

## ■ SYNOPTIC

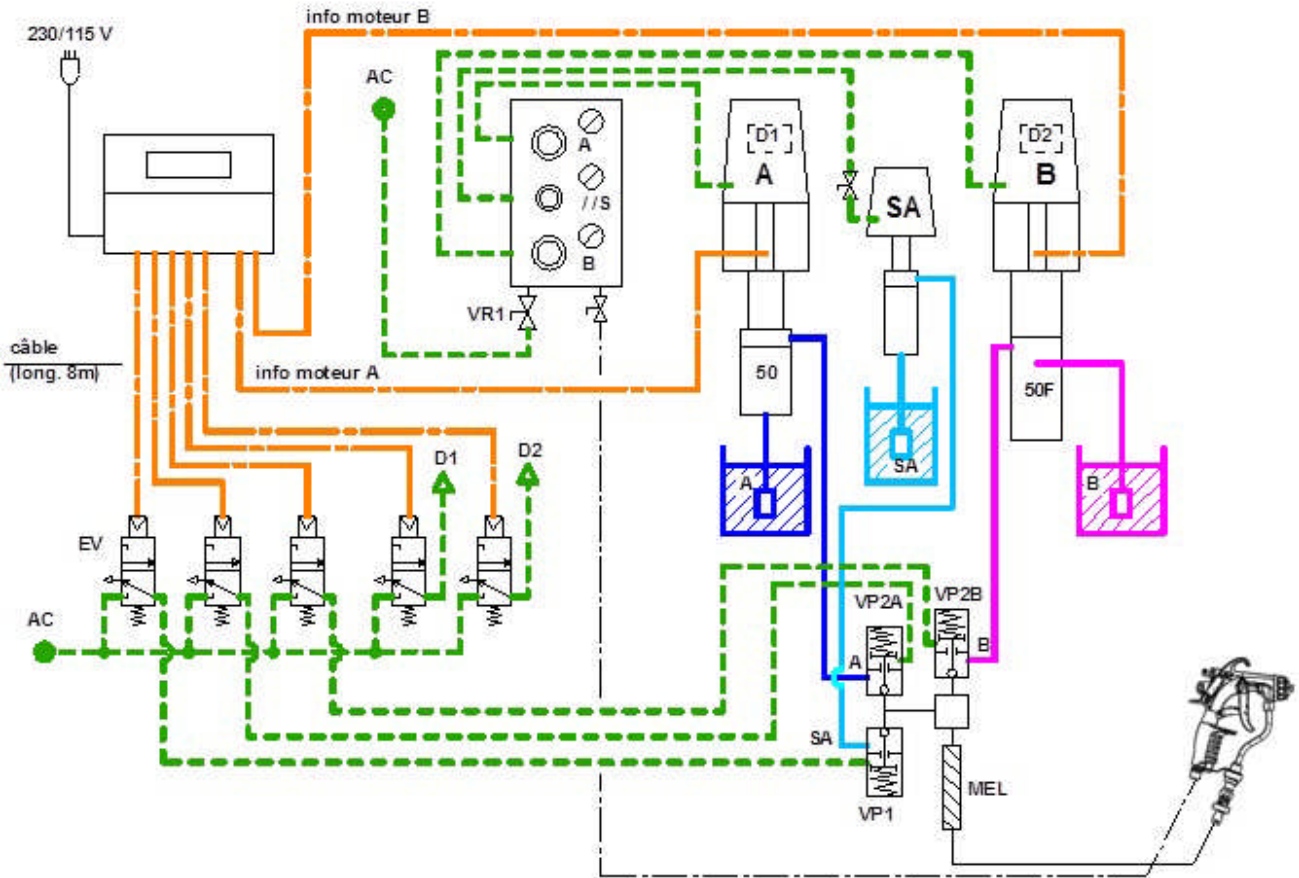

*Nota : diagram of a unit, model PU 3000 Airmix®*

■ MAINTENANCE PLAN

*The life duration of the different elements depends on the properties of the material used. The following maintenance plan is for information only and can not be taken into account when making a complaint.*

SUBSET	ELEMENT	OPERATION TO CARRY OUT	TIME EXPECTED	PERIODICITY	MACHINE STATE	TOOLS
Mixer	Mixer	Remove and install a new mixer	2 mn	1 year	stop	
BASE pump	BASE fluid section	Check the lubricant into the cup : its level (1/2 cup) and its colour (colourless)	2 mn	week	stop	T lubricant
		If the lubricant is contaminated, tighten the wetting cup on the upper packing (or change the seals of the packing, if necessary) ; do that with a depressurized pump	10 mn	month	stop	Wrench supplied
		Remove and clean the parts; change the seals and reinstall.	3 h	1 year	stop	
CATALYST pump	CATA fluid section, model standard	Check the lubricant into the cup : its level (1/2 cup) and its colour (colourless)	2 mn	week	stop	P lubricant
		If the lubricant is contaminated, tighten the wetting cup on the upper packing (or change the seals of the packing, if necessary) ; do that with a depressurized pump	10 mn	month	stop	Wrench supplied
		Remove and clean the parts; change the seals and reinstall.	3 h	1 year	stop	
	CATA fluid section, model Flowmax	Remove and clean the parts; change the seals and reinstall	4 h	1 year	stop	
Flushing pump	Fluid section	Check the lubricant into the cup : its level (1/2 cup) and its colour (colourless)	2 mn	week	stop	T lubricant
		If the lubricant is contaminated, tighten the wetting cup on the upper packing (or change the seals of the packing, if necessary) ; do that with a depressurized pump	10 mn	month	stop	Wrench supplied
		Remove and clean the parts; change the seals and reinstall	2 h	1 year	stop	
Piloted valve	Piloted valve	Remove and change the cartridge	10 mn	1 year	stop	
		Change the piston packing	10 mn	1 year	stop	
Color changer	Piloted valve	Remove and change the cartridge	10 mn	1 year	stop	
		Change the piston packing	10 mn	1 year	stop	

## ■ TROUBLESHOOTING



**For any intervention on the machine :**

- Flush the circuits,
- Shut off the compressed air,
- Depressurize the hoses by triggering the gun,
- Shut off the electric supply.

If a problem occurs during the machine operation, alarms will be displayed on the screen of the machine.

Input **OK** to disable each alarm.

TROUBLES	CAUSES	SOLUTIONS
Err A	Trouble on the BASE fluid section	Check the BASE circuit : - material in the drum, - suction rod strainer, - pump valves. Clean or change.  Check the CATALYST pressure towards the BASE pressure.
Err b	Trouble on the CATALYST fluid section	Check the CATALYST circuit : - material in the drum, - suction rod strainer, - pump valves. Clean or change.  Check the CATALYST pressure towards the BASE pressure.
Err 1	Incorrect mixing ratio Flow incorrectly adjusted	Check the material levels in the supply drums.  Check the starting of the pumps.  Check the CATALYST pressure towards the BASE pressure.
Err 4	Irrelevant data capture between the ratio and the injection volume (Machine unable to give the parameters requested)	Check that the P1 parameter (ratio) and the P6 parameter (injection volume) are compatible in injection capability terms in relation to the ratio requested (refer to § 12).

## ■ DIAGNOSTICS

### ELECTRIC

FAULTS	CHECKINGS
The machine does not switch on	Check that the isolating switch is on 'I'.
	Check that the mains supply is connected. No : connect it.
	Check that the fuse on the electric card inside the box is in working order. No : change the fuse.
	Check the electric wiring of the supply cable (bad contact or other)

## MATERIAL

FAULTS	CHECKINGS
No fluid flows when passing into production or flushing mode.	Check if the valves are open : <b>No</b> : - Check air supply (minimum 4 bar / 58 psi), - Check the connection of the 25 pts cable, - Check the correct operating of the electrovalves. <b>Yes</b> : - Check the fluid pressure, - Check the static mixer.
The machine displays the correct mixing but the consumption of catalyst is too important.	Check the grounds of the machine (230V intake and ground cable of the fluid module)
The machine displays the correct mixing but the consumption of catalyst is not enough.	Check the grounds of the machine.
When the main menu page is displayed, fluid flows out when the gun is open.	Check the valves Checking of the valve : look at what is flowing -if it is solvent, change the valve (VP1) -if it is base, change the valve (VP2A) -if it is catalyst, change the valve (VP2B)

## 12. PROPORTION AND OUTPUT ACCORDING TO THE RATIO

### ■ PU 3000 PNEUMATIC, AIRMIX® AND AIRLESS VERSIONS

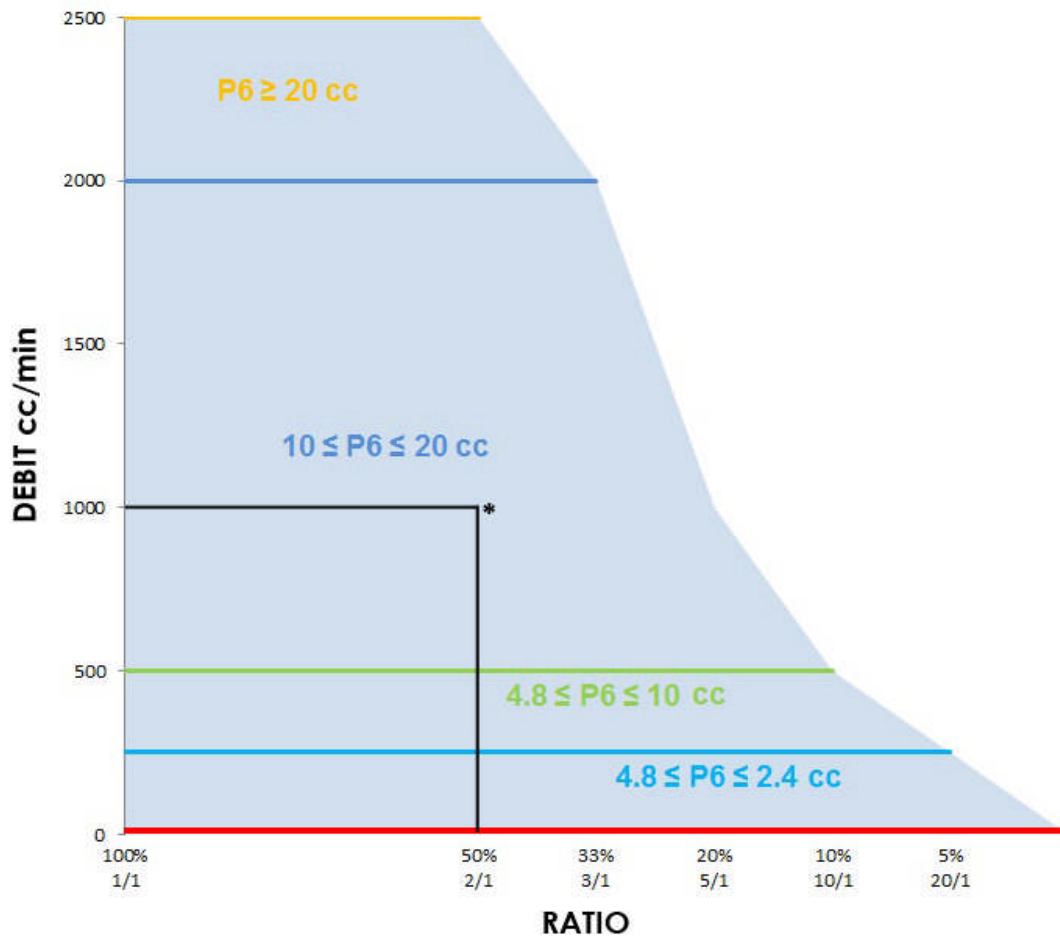

 Operating area of the PU 3000 pneumatic, Airmix® and Airless

\* Example :

If you want to get a flow rate of 1000cc/min with a proportion of 2/1 (50%), then the P6 parameter (injection volume of the catalyst) must be adjust between 10 and 20cc.

Nota :

- Tests carried out with same fluid viscosity materials.
- The adjustments of pressure and of injection value depend upon the fluid viscosity of the used material.
- The P6 parameter impacts the mixture, you should confirm this parameter by using the mixture on the part you want to paint.



■ PU 3000 4 L 30/1 AND 4 L 53/1 VERSIONS

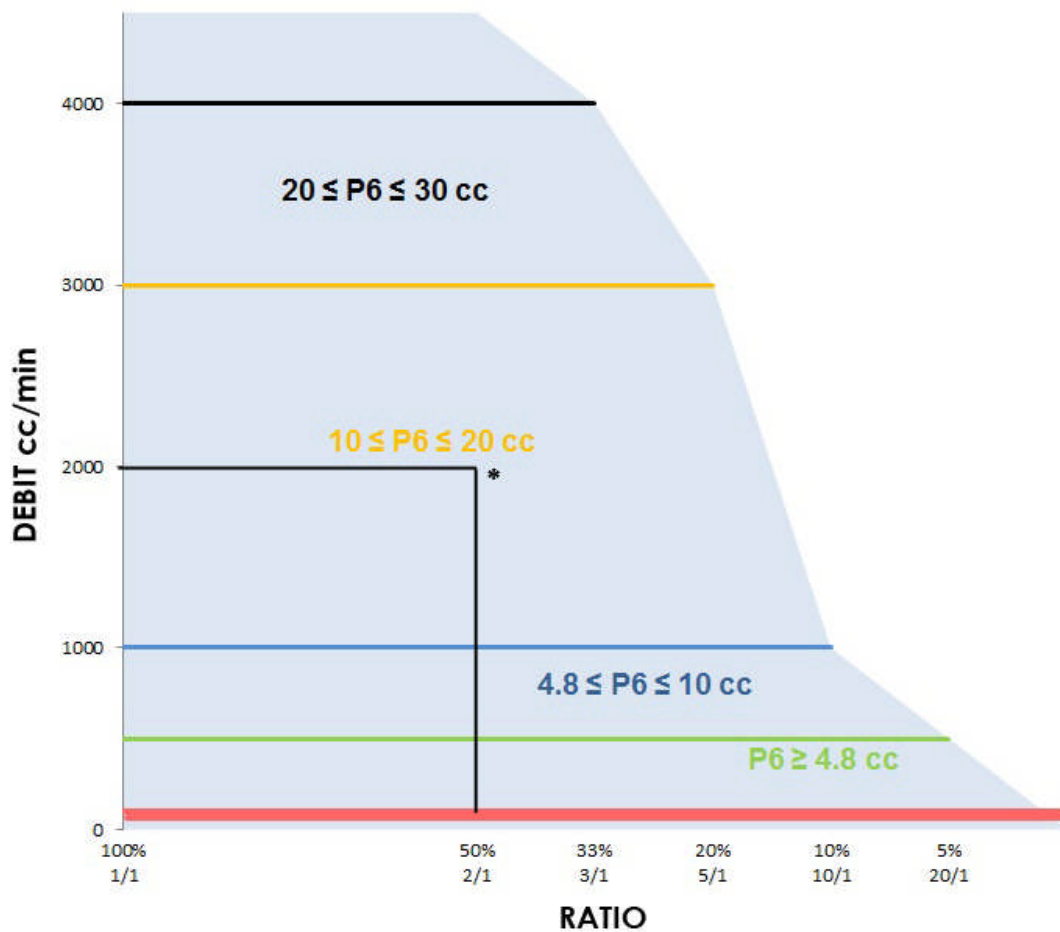

Operating area of the PU 3000 4 L 30/1 and 4 L 53/1

\* Example :

If you want to get a flow rate of 2000cc/min with a proportion of 2/1 (50%), then the P6 parameter (injection volume of the catalyst) must be adjust between 10 and 20cc.

Nota :

- Tests carried out with same fluid viscosity materials.
- The adjustments of pressure and of injection value depend upon the fluid viscosity of the used material.
- The P6 parameter impacts the mixture, you should confirm this parameter by using the mixture on the part you want to paint.

### 13. MIXING RATIO

A : Base

B : Catalyst

$B / A \times 100 = X\%$

Ex : A = 2.5 B = 1  $\Rightarrow 1 / 2.5 \times 100 = 40\%$

A	B	%
0.625	1	160
1	1	100
1.5	1	66.7
2	1	50
2.5	1	40
3	1	33.3
3.5	1	28.6
4	1	25
4.5	1	22.2
5	1	20
5.5	1	18.2
6	1	16.7
6.5	1	15.4
7	1	14.3
7.5	1	13.3
8	1	12.5
8.5	1	11.8
9	1	11.1
9.5	1	10.5
10	1	10

A	B	%
10.5	1	9.524
11	1	9.091
11.5	1	8.696
12	1	8.333
12.5	1	8
13	1	7.692
13.5	1	7.407
14	1	7.143
14.5	1	6.897
15	1	6.667
15.5	1	6.452
16	1	6.25
16.5	1	6.061
17	1	5.882
17.5	1	5.714
18	1	5.556
18.5	1	5.405
19	1	5.263
19.5	1	5.128
20	1	5

### 14. PNEUMATIC AND ELECTRIC DIAGRAMS

Refer to appendices (Doc. # 055.680.031)

**SPECIFICATIONS**

**PU 3000 PUMP**

**- model Pneumatic & model Airmix®**

## 15. FEATURES - PU 3000 PNEUMATIC

### ■ COMPOSITION

<b>BASE pump</b>	Motor :	1500 (only for PU 3000)
	Fluid section :	50 (standard)
<b>CATALYST pump</b>	Motor :	1500 (only for PU 3000)
	Fluid section :	50 F (Flowmax)
<b>Flushing pump</b>	Option :	Flushing pump, model EOS 02-C85

### ■ TECHNICAL FEATURES

Maximum air supply pressure	6 bar / 87 psi
Maximum fluid outlet pressure of the PU 3000	0-6 bar / 0-87 psi or 6-40 bar / 87-580 psi
Proportioning ratio / Fluid flow rate	Refer to charts (§ 12 & 13)
Electrical supply of the supply unit	115V / 230V - 10W
Air inlet connection	F 3/4 BSP (air inlet valve)
Fluid outlet connection (mixer)	F 3/4 JIC



The control box of the PU 3000 mixing machine must be installed outside the spray booth.

### ■ SPECIFIC PARAMETERS

Parameters	Description	Factory adjustment	Your adjustments
<b>F3- -P4</b>	Section of the A piston Minimum value: 1 mm <sup>2</sup> Maximum value : 99 999 mm <sup>2</sup>	485 (for fluid section, model 50)	
<b>F3- -P5</b>	Section of the B piston Minimum value: 1 mm <sup>2</sup> Maximum value : 99 999 mm <sup>2</sup>	490 (for fluid section, model 50 F)	

## 16. FEATURES - PU 3000 AIRMIX®

### ■ COMPOSITION

<b>BASE pump</b>	Motor :	3000 (only for PU 3000)
	Fluid section :	50 (standard)
<b>CATALYST pump</b>	Motor :	3000 (only for PU 3000)
	Fluid section :	50 F (Flowmax)
<b>Flushing pump</b>	Option :	Flushing pump, model EOS 30-C25

### ■ TECHNICAL FEATURES

Maximum air supply pressure	6 bar / 87 psi
Maximum fluid outlet pressure of the PU 3000	180 bar / 2610.5 psi
Proportioning ratio / Fluid flow rate	Refer to charts (§ 12 & 13)
Electrical supply of the supply unit	115V / 230V - 10W
Air inlet connection	F 3/4 BSP (air inlet valve)
Fluid outlet connection (mixer)	F 3/4 JIC



The control box of the PU 3000 mixing machine must be installed outside the spray booth.

### ■ SPECIFIC PARAMETERS

Parameters	Description	Factory adjustment	Your adjustments
<b>F3- -P4</b>	Section of the A piston Minimum value: 1 mm <sup>2</sup> Maximum value : 99 999 mm <sup>2</sup>	465 (for fluid section, model 50)	
<b>F3- -P5</b>	Section of the B piston Minimum value: 1 mm <sup>2</sup> Maximum value : 99 999 mm <sup>2</sup>	470 (for fluid section, model 50 F)	

## 17. DISASSEMBLY & REASSEMBLY - PU 3000 PNEUMATIC, PU 3000 AIRMIX®



**CAUTION :** Before any work is carried on the pump, stop the machine after carrying out flushing, shut off the compressed air supply and depressurize the circuits triggering the gun.

**The pump is manufactured under the ATEX agreement and can not be modified. KREMLIN REXSON will not be held responsible for any failure to comply with that instruction.**

### ■ MIXER

Unscrew the mixer assembly and replace it with a new one.

### ■ PILOTED VALVES

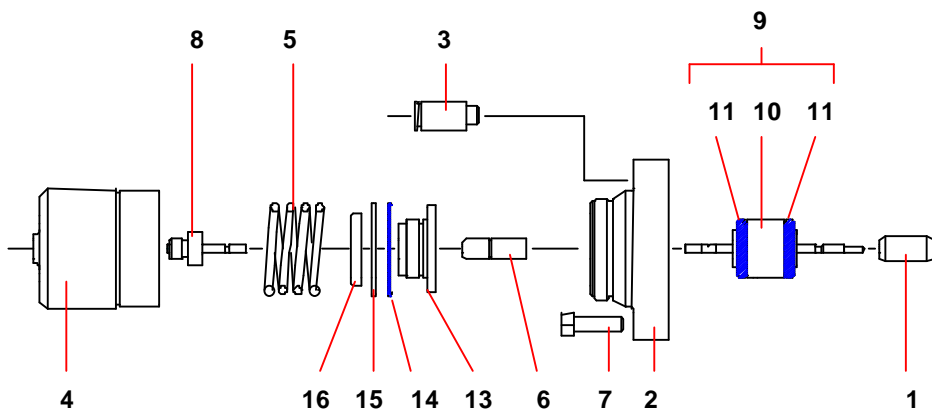

#### CARTRIDGE OF A FLUID VALVE (IND. 9)

Loosen the 3 screws (7) and take off the valve from the module body.

Unscrew the needle (1). Unscrew the cylinder (4).

Hold the rod strainer (6), unscrew the needle rod and remove the cartridge assembly with rod (9).

Assemble the new cartridge (9) into the cylinder support (2) pushing it until the shoulder of the cartridge rests on the shoulder of that support, then reassemble all parts of the valve in the reverse order of the disassembly.

Present the valve in front of the module body.

Center the cartridge (9) on the module body then reassemble the screws (7).

#### PISTON PACKING (IND. 14)

Unscrew the cylinder (4).

Remove the spring (5).

Unscrew the opening signal light (8).

Unscrew the nut (16).

Remove the support washer (15) and the packing (14).

Clean the parts and change them if necessary.

#### Before reassembling :

**Before assembling on the piston (13), take care of shaping the cartridge lip (14) by hand as shown in the above drawing (cartridge turned up on the piston).**

The nut (16) must be glued on the piston (13) with loctite adhesive (eg : Loctite 222).

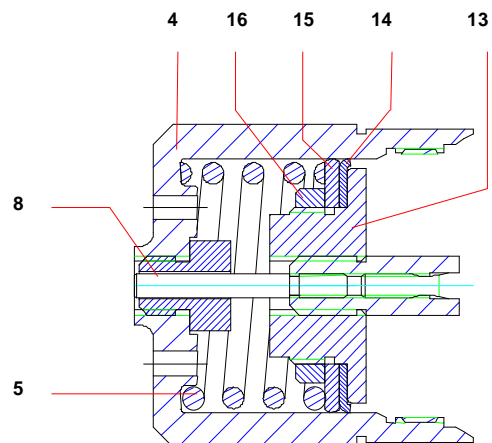

■ **FLUID SECTION, MODEL 50 (BASE) (REFER TO DOC. 573.080.050)**

**Guards (air motor cover, coupling shields, housings ...) have been designed for safe use of the equipment.**  
**The manufacturer will not be held responsible for bodily injury or failure and / or damage to property due to removal or partial removal of the guards.**

**SUCTION VALVE**

Unscrew the suction valve (5) holding the cylinder (2).

The ball (10) is secured on the valve (5) by means of a circular rush (9).

Clean the parts.

Reinstall the suction valve (5) and the seal (25) changing the parts if necessary.

**EXHAUST VALVE AND MOBILE PACKING**

Unscrew the cylinder (2) and pull it downwards.

Unscrew the exhaust valve (6) holding the piston (3).

Take off the ball (17), the washer (12) and the seal (13).

Clean the parts.

Carry out the reassembly in the reverse order of the disassembly :

- Install the GT seal (13), the GT washer (12) and the ball (17) on the exhaust valve (6).
- Screw the exhaust valve (6) into the piston. Tighten up the seal on the exhaust valve (6).

Change the seal (8) if necessary when assembling the cylinder (2).

**UPPER PACKING**

Disassemble the piston rod from the motor and the piston (3) from the fluid section.

Unscrew the wetting-cup (4) by means of the wrench supplied with the pump.

Pull the piston (3) upwards to remove the seals (21 and 22) from the upper packing (18).

Reinstall the seals (21 and 22) taking care of the **direction**, the **order** and the **dimension** of assembly.

Tighten the wetting cup (4).

**After reassembling the parts, fill the pump with solvent and increase the pressure to its maximum. Stop the pump and depressurize opening the drain valve.**

**Tighten the wetting cup (4) by means of the wrench to be in accordance with the above drawing.**

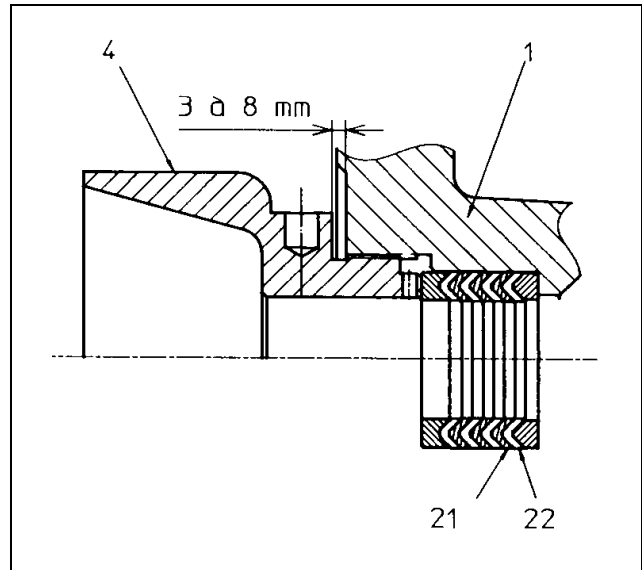

**Before reassembling the different components :**

- Clean the parts with the appropriate cleaning solvent,
- Install new seals if necessary after having lubricated them with PTFE grease,
- Install new parts if necessary..

**ASSEMBLY INSTRUCTIONS (FLUID SECTION, MODEL 50)**

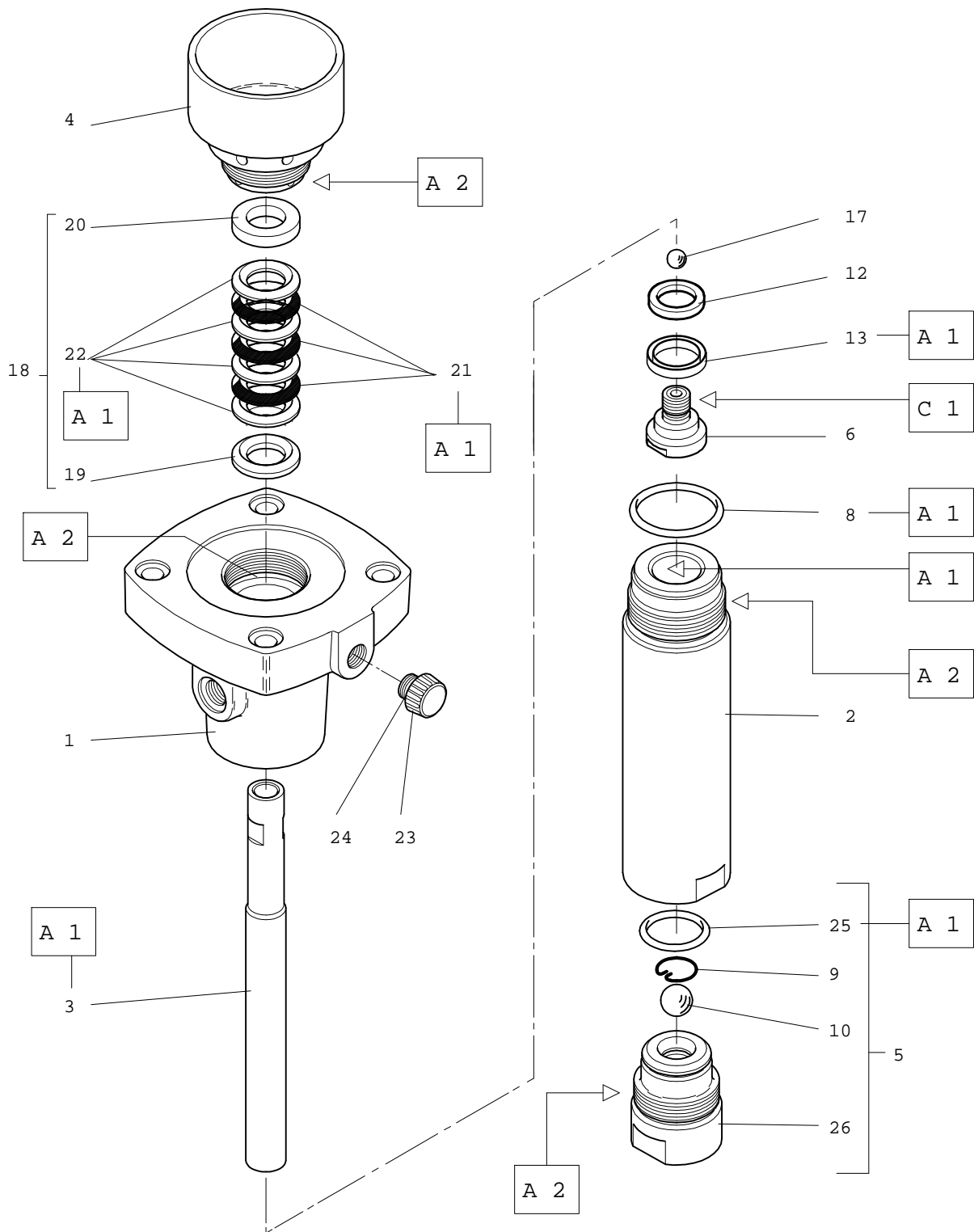

Index	Instruction	Description	Part number
A 1	PTFE grease	PTFE grease (10 ml)	560.440.101
A 2	Anti-seize grease	Grease box (450 g / 99 lb)	560.420.005
C 1	Medium strength Aneorobic Pipe sealant	Loctite 577	-



■ **FLUID SECTION, MODEL 50 F (CATALYST) (REFER TO DOC. 573.114.050)**

**Guards (air motor cover, coupling shields, housings ...) have been designed for safe use of the equipment.**  
**The manufacturer will not be held responsible for bodily injury or failure and / or damage to property due to removal or partial removal of the guards.**

**1 - DISASSEMBLY / ASSEMBLY OF THE FLUID SECTION PART**

Unscrew the fitting nut (38) and the screws (41 and 43) to remove the connection tube (39).

**SUCTION VALVE**

Unscrew the suction valve (35) holding the cylinder (27).

The ball (22) is secured on the valve (35) by means of a circular rush (21).

Clean the parts.

Reinstall the suction valve (35) and the seal (23) changing parts if necessary.

**EXHAUST VALVE AND MOBILE PACKING**

Unscrew the cylinder (27) and pull it downwards.

Unscrew the wetting cup (33) to take off the GT seal (31) from the exhaust valve (34).

Unscrew the exhaust valve (34) holding the piston (24).

Remove the ball (32).

Clean the parts and reinstall then changing the seals if necessary.

**UPPER TIGHTNESS SEAL**

Unscrew the 4 screws (30).

Remove the tightness seal (28) pulling the exhaust valve (25) downwards.

Change the tightness seal (28), the O-Rings (29 and 11).

Reinstall the parts in the reverse order of the disassembly sequence.

**2 - DISASSEMBLY - ASSEMBLY OF THE COUPLING (WITH BELLOWS)**

**That operation must be carried out after the disassembly of the fluid section part.**

**BELLOWS**

Unscrew the nuts (14) from the coupling tie-rods.

Take off the suction flange (1) and the cylinder (2) pulling them downwards.

Remove screws (12) to separate the suction bearing (3) from the motor.

Separate the intermediate piston (9) from the motor rod.

Put aside the coupling with bellows assembly.

Disassemble the bellows' flange (4) removing the screws (13) to take off the upper part from the bellows.

Unscrew the skirt (8) to take off the lower part from the bellows.

**Change the bellows (5).**

Install the new bellows pushing it into skirt (8) firmly.

Insert the intermediate piston (9) inside the bellows (5) and screw the skirt at its end.

Insert the bellows and the piston (9) into the bearing (3).

Install the flange (4) into bellows (3) and tighten the whole with the screws (13).

Connect bellows-piston assembly with the motor rod and secure it to the lower support of the motor with the screws (12).

Reinstall the fluid section piston (24) on the intermediate piston (9).

Change the seals (11) then reinstall the cylinder (2) and the suction flange (1).

Install the whole on the tie-rods and tighten the nuts (14).

**Before reassembling the different components :**

- Clean the parts with the appropriate cleaning solvent,
- Install new seals if necessary, after having lubricated them with PTFE grease.
- Lubricate the piston and the inside of the cylinder to prevent from damaging the seals,
- Install new parts if necessary.

**ASSEMBLY INSTRUCTIONS**

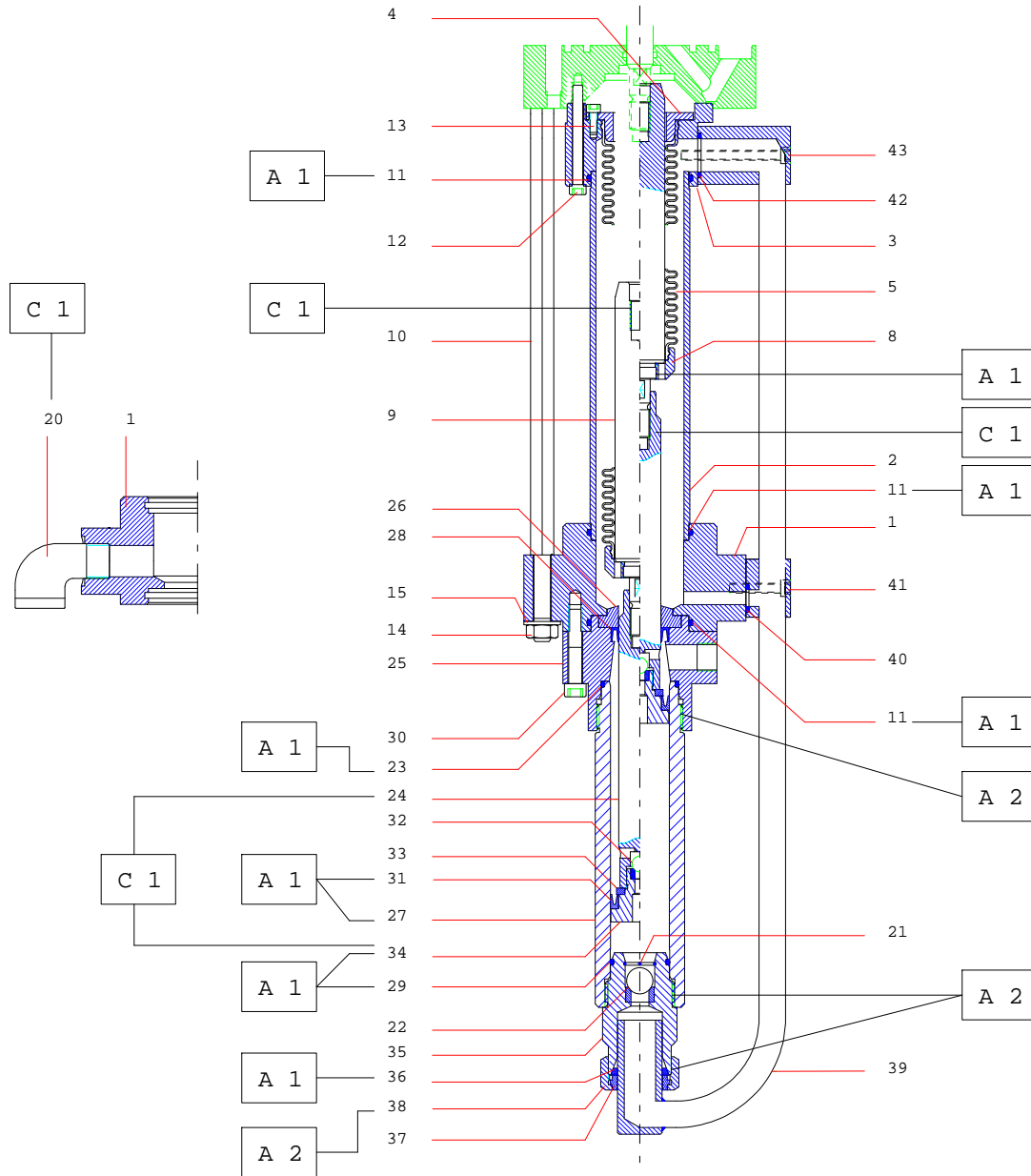

Index	Instruction	Description	Part number
A 1	PTFE grease	PTFE grease (10 ml)	560.440.101
A 2	Anti-seize grease	Grease box (450 g / 99 lb)	560.420.005
C 1	Medium strength Aneorobic Pipe sealant	Loctite 577	-

## **SPECIFICATIONS**

**PU 3000 PUMP - model Airless**

## 18. FEATURES - PU 3000 AIRLESS

### ■ COMPOSITION

<b>BASE pump</b>	Motor :	5000 (only for PU 3000)
	Fluid section :	50 cc (standard)
<b>CATALYST pump</b>	Motor :	5000 (only for PU 3000)
	Fluid section :	50 cc (standard)
<b>Flushing pump</b>	Option :	Flushing pump, model EOS 30-C25

### ■ TECHNICAL FEATURES

Maximum air supply pressure	6 bar / 87 psi
Maximum fluid outlet pressure of the PU 3000	360 bar / 5222 psi
Proportioning ratio / Fluid flow rate	Refer to charts (§ 12 & 13)
Electrical supply of the supply unit	115V / 230V - 10W
Air inlet connection	F 3/4 BSP (air inlet valve)
Fluid outlet connection (mixer)	F 3/4 JIC



**The control box of the PU 3000 mixing machine must be installed outside the spray booth.**

### ■ SPECIFIC PARAMETERS

Parameters	Description	Factory adjustment	Your adjustments
<b>F3- -P4</b>	Section of the A piston Minimum value : 1 mm2 Maximum value : 99 999 mm2	555 (for fluid section, model 50cc)	
<b>F3- -P5</b>	Section of the B piston Minimum value : 1 mm2 Maximum value : 99 999 mm2	555 (for fluid section, model 50cc)	

## 19. DISASSEMBLY & REASSEMBLY - PU 3000 AIRLESS



**CAUTION :** Before any work is carried on the pump, stop the machine after carrying out flushing, shut off the compressed air supply and depressurize the circuits triggering the gun.

**The pump is manufactured under the ATEX agreement and can not be modified. KREMLIN REXSON will not be held responsible for any failure to comply with that instruction.**

### ■ MIXER

Unscrew the mixer assembly and replace it with a new one.

### ■ ASI 40 VALVES (REFER TO DOC. 573.062.050)

#### **FLUID PACKING (IND. 22) AND NEEDLE WITH BALL (IND. 37)**

Unscrew the diaphragm (9), the seat-holder assembly (17).

Take off the 2 screws (13).

Disassemble the needle holder (23) from the needle strainer (6) to remove the front body (1) from the gun.

Take off the circlip (26) holding the fluid packing (22).

Remove the fluid packing (22) pulling the needle frontwards.

Unscrew the ball needle (37) from the needle holder (23).

Change the fluid packing and its seal (24).

Clean the front part of the gun.

When assembling, drive fluid packing (22) by pushing it from the front part to the rear part of the body (1) until the packing shoulder comes to lean against the shoulder located inside the gun.

Then, secure the fluid packing by means of the circlip (26).

Reinstall the ball needle (37), the screws (13), the seat-holder assembly (17), the diaphragm (9), the tip and the coupling nut (8).

#### **PISTON ASSEMBLY (IND. 27)**

Unscrew the 4 screws (11).

Remove the spring guide (3) and the cylinder (2).

Take off the spring (7), the spring support (33).

Unscrew the nut (31).

Remove the washer (30) and the piston packing (29).

Clean the parts and change them if necessary.

**Nota :** Before inserting the piston assembly (27) into the cylinder, the packing lip (29) must be shaped by hand as shown opposite (cartridge turned up on the piston).

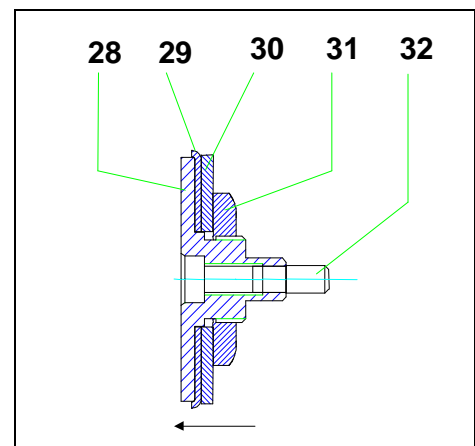

#### **AIR PACKING (IND. 34)**

Take off the back part of the gun and remove the piston as explained before.

Remove the air packing (34).

Replace the packing seal (36) or the air packing assembly.

*Nota :* when changing the ASI 40 valve from the PU 3000 fluid equipment, take off the fittings from the spare valve delivered, then install it on the fluid equipment.

■ FLUID SECTION, MODEL ALTO 50CC (BASE & CATALYST) (REFER TO DOC. 573.395.050)



**WARNING!**

Before any action on the pump, shut off the compressed air supply and depressurize the systems by triggering the spray gun.

**Guards (air motor cover, coupling shields, housings ...) have been designed for safe use of the equipment.**  
**The manufacturer will not be held responsible for bodily injury or failure and / or damage to property due to removal or partial removal of the guards.**

**Disassembly of the pump**

- Unscrew the 2 nuts (22) and put aside the flange (20), the tie-rods (21) and the protective housing (23),
- Clamp the pump horizontally through the body (2) into a vice,
- Unscrew the valve body assembly (14),
- Take off the piston (8) downwards,
- Put aside the cylinder (7).

**Lower valve**

- Push on the ball (16) to remove the spacer (17),
  - Take off the seat (15), the seal (19) and the pin (18),
  - Put aside the seal (13),
  - Clean the parts, check them if they are not worn or damaged.
- Reinstall the parts in the reverse order of the disassembly sequence.

**Cup seals**

- Unscrew the cup nut (1),
  - Take off the washers (3 & 5),
  - Put aside the seals: PTFEG seals (4a) & UHMW seals (4b),
  - Clean the parts, check them if they are not worn or damaged.
- Reinstall the parts in the reverse order of the disassembly sequence

**Piston head seals**

- Unscrew the seat (10),
- Take off the ball (11), the washers (3 & 5) and the seals (12),
- Change the seals : PTFE G seals (12a) & UHMW seals (12b),
- Clean the parts, check them if they are not worn or damaged.

**Complete assembly of the fluid section**

- Lubricate the cup seals and the piston head seals,
- Slide the piston rod assembly (8) inside the body (2), push it upwards,
- Screw the cylinder (7) (to stop) into the body (2),
- Screw the valve body assembly (14) to stop, tighten slightly,
- Reinstall the protective housing (23), the connection flange (20) and the tie-rods (21). Screw the two nuts (22),
- Assemble the pump to the pneumatic motor.

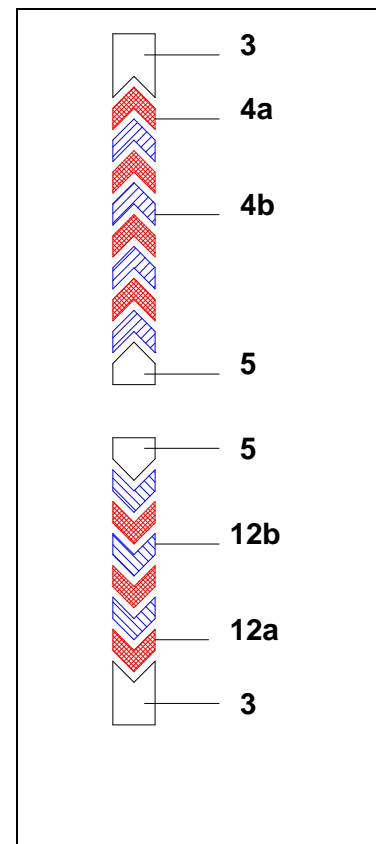

Before intervening on the equipment :

- Clean the parts with the appropriate cleaning solvent,
- Install new seals if necessary, after having lubricated them with grease.
- Lubricate the piston and the inside of the cylinder to prevent from damaging the seals,
- Install new parts if necessary.

**ASSEMBLY INSTRUCTIONS (FLUID SECTION, MODEL 50cc)**

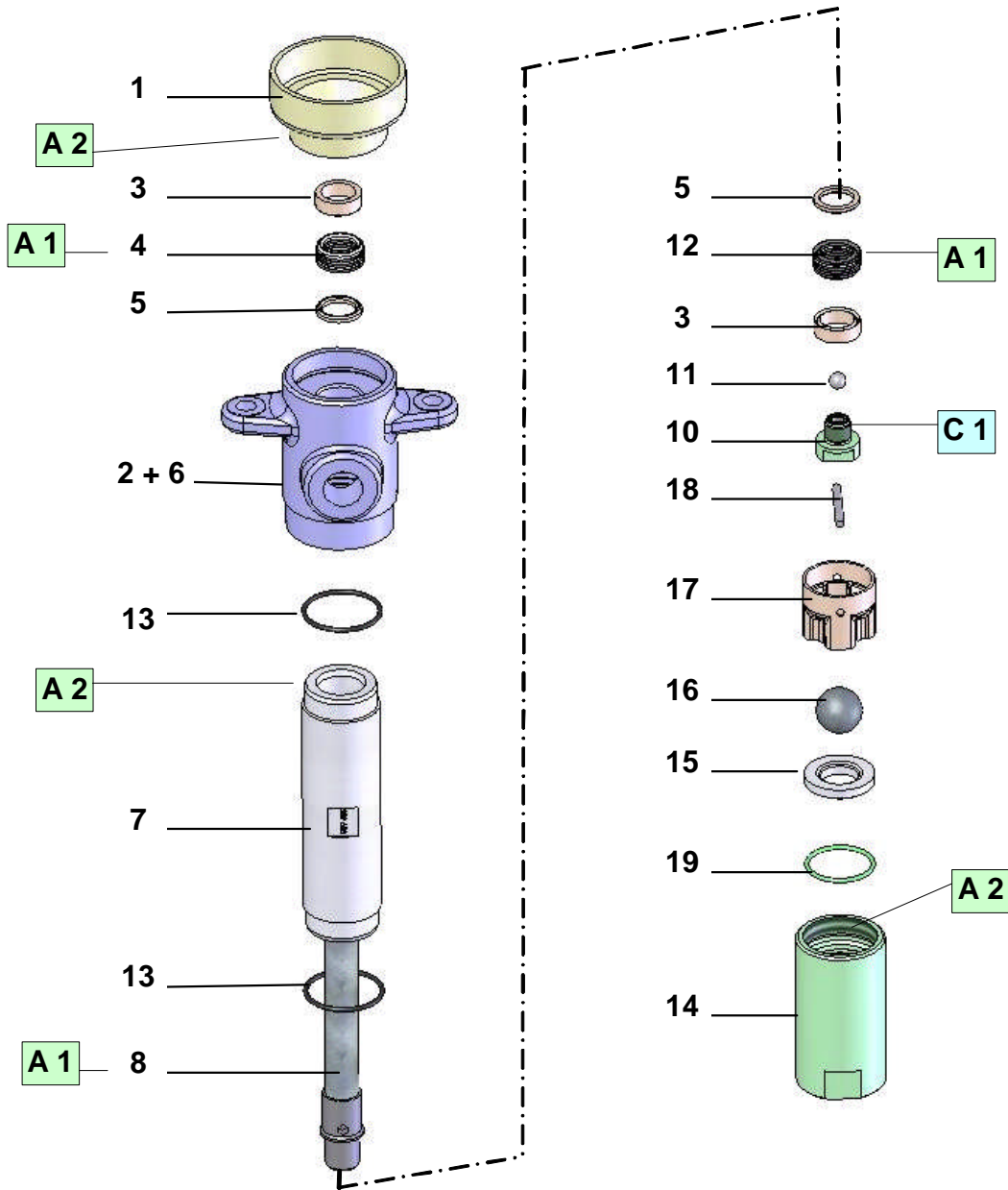

Index	Instruction	Description	Part number
A 1	PTFE grease	PTFE grease (10 ml)	560.440.101
A 2	Anti-seize grease	Grease box (450 g / 99 lb)	560.420.005
C 1	Medium strength Aneorobic Pipe sealant	Loctite 577	-

## **SPECIFICATIONS**

**PU 3000 PUMP - model 4 L 30/1**



## 20. FEATURES - PU 3000 4 L 30/1

### ■ COMPOSITION

<b>BASE pump</b>	Motor :	5000 (only for PU 3000)
	Fluid section :	225cc (standard)
<b>CATALYST pump</b>	Motor :	5000 (only for PU 3000)
	Fluid section :	225cc (standard)
<b>Flushing pump</b>	Option :	Flushing pump, model EOS 30-C25

### ■ TECHNICAL FEATURES

Maximum air supply pressure	6 bar / 87 psi
Maximum fluid outlet pressure of the PU 3000	180 bar / 2610.5 psi
Proportioning ratio / Fluid flow rate	Refer to charts (§ 12 & 13)
Electrical supply of the supply unit	115V / 230V - 10W
Air inlet connection	F 3/4 BSP (air inlet valve)
Fluid outlet connection (mixer)	F 3/4 JIC



The control box of the PU 3000 mixing machine must be installed outside the spray booth.

### ■ SPECIFIC PARAMETERS

Parameters	Description	Factory adjustment	Your adjustments
<b>F3- -P4</b>	Section of the A piston Minimum value: 1 mm <sup>2</sup> Maximum value : 99 999 mm <sup>2</sup>	1010 (for fluid section, model 225cc)	
<b>F3- -P5</b>	Section of the B piston Minimum value: 1 mm <sup>2</sup> Maximum value : 99 999 mm <sup>2</sup>	1010 (for fluid section, model 225cc)	

## 21. DISASSEMBLY & REASSEMBLY - PU 3000 4 L 30/1



**CAUTION :** Before any work is carried on the pump, stop the machine after carrying out flushing, shut off the compressed air supply and depressurize the circuits triggering the gun.

**The pump is manufactured under the ATEX agreement and can not be modified. KREMLIN REXSON will not be held responsible for any failure to comply with that instruction.**

### ■ MIXER

Unscrew the mixer assembly and replace it with a new one.

### ■ ASI 40 VALVES (REFER TO DOC. 573.062.050)

#### **FLUID PACKING (IND. 22) AND NEEDLE WITH BALL (IND. 37)**

Unscrew the diaphragm (9), the seat-holder assembly (17).

Take off the 2 screws (13).

Disassemble the needle holder (23) from the needle strainer (6) to remove the front body (1) from the gun.

Take off the circlip (26) holding the fluid packing (22).

Remove the fluid packing (22) pulling the needle frontwards.

Unscrew the ball needle (37) from the needle holder (23).

Change the fluid packing and its seal (24).

Clean the front part of the gun.

When assembling, drive fluid packing (22) by pushing it from the front part to the rear part of the body (1) until the packing shoulder comes to lean against the shoulder located inside the gun.

Then, secure the fluid packing by means of the circlip (26).

Reinstall the ball needle (37), the screws (13), the seat-holder assembly (17), the diaphragm (9), the tip and the coupling nut (8).

#### **PISTON ASSEMBLY (IND. 27)**

Unscrew the 4 screws (11).

Remove the spring guide (3) and the cylinder (2).

Take off the spring (7), the spring support (33).

Unscrew the nut (31).

Remove the washer (30) and the piston packing (29).

Clean the parts and change them if necessary.

**Nota :** Before inserting the piston assembly (27) into the cylinder, the packing lip (29) must be shaped by hand as shown opposite (cartridge turned up on the piston).

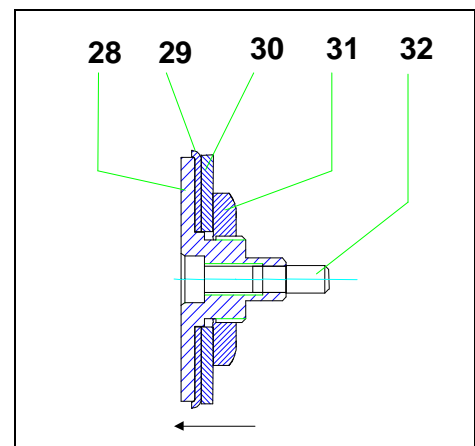

#### **AIR PACKING (IND. 34)**

Take off the back part of the gun and remove the piston as explained before.

Remove the air packing (34).

Replace the packing seal (36) or the air packing assembly.

*Nota :* when changing the ASI 40 valve from the PU 3000 fluid equipment, take off the fittings from the spare valve delivered, then install it on the fluid equipment.

■ FLUID SECTION, MODEL ALTO 225CC (BASE & CATALYST) (REFER TO DOC. 573.451.050)



**WARNING!**

Before any action on the pump, shut off the compressed air supply and depressurize the systems by triggering the spray gun.

**Guards (air motor cover, coupling shields, housings ...) have been designed for safe use of the equipment.  
The manufacturer will not be held responsible for bodily injury or failure and / or damage to property due to removal or partial removal of the guards.**

**Disassembly of the pump**

- Unscrew the 2 nuts (16) and put aside the flange (1), the tie-rods (10) and the protective housing (4),
- Clamp the pump horizontally through the body (7) into a vice,
- Unscrew the valve body assembly (23),
- Take off the piston (11) downwards,
- Put aside the cylinder (21).

**Lower valve**

- Push on the ball (19) to remove the spacer (18),
  - Take off the seat (20), the seal (22) and the pin (24),
  - Put aside the seal (9),
  - Clean the parts, check them if they are not worn or damaged.
- Reinstall the parts in the reverse order of the disassembly sequence.

**Cup seals**

- Unscrew the cup nut (5),
  - Take off the washers (6 & 13),
  - Put aside the seals: PE seals (12a) & PTFE G seals (12b)
  - Clean the parts, check them if they are not worn or damaged.
- Reinstall the parts in the reverse order of the disassembly sequence

**Piston head seals**

- Unscrew the seat (17),
- Take off the ball (15), the washers (6 & 13) and the seals (12),
- Change the seals: PE seals (12a) & PTFE G seals (12b),
- Clean the parts, check them if they are not worn or damaged.

**Complete assembly of the fluid section**

- Lubricate the cup seals and the piston head seals,
- Slide the piston rod assembly (11) inside the body (7), push it upwards,
- Screw the cylinder (21) (to stop) into the body (7),

- Screw the valve body assembly (23) to stop, tighten slightly,
- Reinstall the protective housing (4), the connection flange (1) and the tie-rods (10). Screw the two nuts (16),
- Assemble the pump to the pneumatic motor.

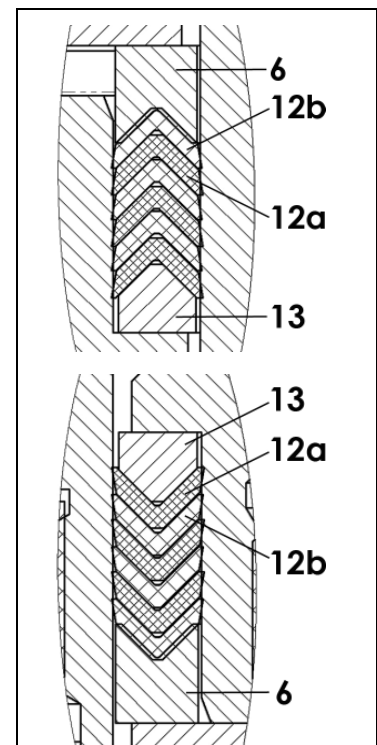

Before intervening on the equipment :

- Clean the parts with the appropriate cleaning solvent,
- Install new seals if necessary, after having lubricated them with grease.
- Lubricate the piston and the inside of the cylinder to prevent from damaging the seals,
- Install new parts if necessary.

**ASSEMBLY INSTRUCTIONS (FLUID SECTION, MODEL 225CC)**

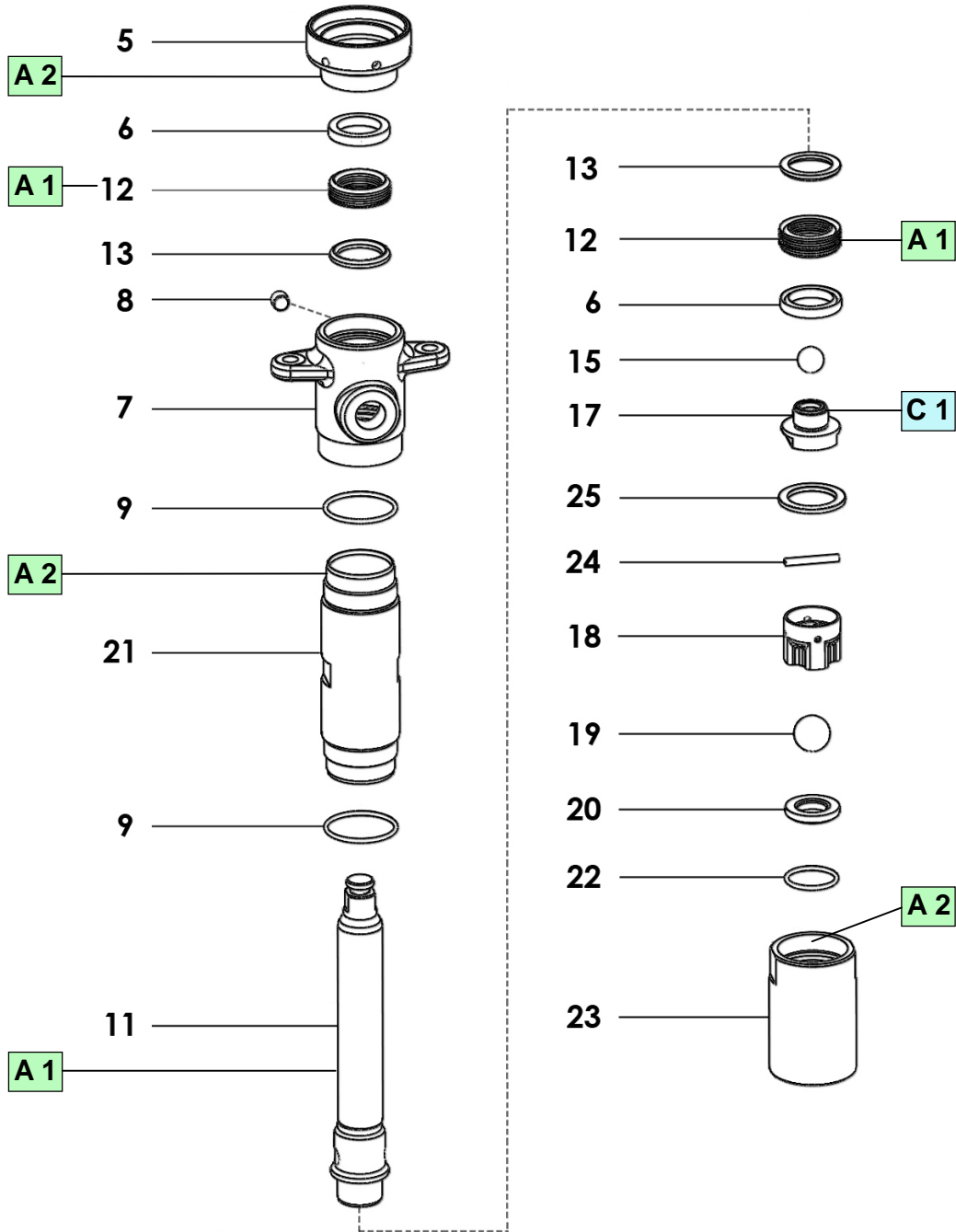

Index	Instruction	Description	Part number
A 1	PTFE grease	PTFE grease (10 ml)	560.440.101
A 2	Anti-seize grease	Grease box (450 g / 99 lb)	560.420.005
C 1	Medium strength Aneorobic Pipe sealant	Loctite 577	-

## **SPECIFICATIONS**

**PU 3000 PUMP - model 4 L 53/1**

## 22. FEATURES - PU 3000 4 L 53/1

### ■ COMPOSITION

<b>BASE pump</b>	Motor :	7000 (only for PU 3000)
	Fluid section :	227cc (standard)
<b>CATALYST pump</b>	Motor :	7000 (only for PU 3000)
	Fluid section :	227cc (standard)
<b>Flushing pump</b>	Option :	Flushing pump, model EOS 30-C25

### ■ TECHNICAL FEATURES

Maximum air supply pressure	6 bar / 87 psi
Maximum fluid outlet pressure of the PU 3000	360 bar / 5222 psi
Proportioning ratio / Fluid flow rate	Refer to charts (§ 12 & 13)
Electrical supply of the supply unit	115V / 230V - 10W
Air inlet connection	F 3/4 BSP (air inlet valve)
Fluid outlet connection (mixer)	F 3/4 JIC



The control box of the PU 3000 mixing machine must be installed outside the spray booth.

### ■ SPECIFIC PARAMETERS

Parameters	Description	Factory adjustment	Your adjustments
<b>F3- -P4</b>	Section of the A piston Minimum value : 1 mm <sup>2</sup> Maximum value : 99 999 mm <sup>2</sup>	1025 (for fluid section, model 227cc)	
<b>F3- -P5</b>	Section of the B piston Minimum value : 1 mm <sup>2</sup> Maximum value : 99 999 mm <sup>2</sup>	1025 (for fluid section, model 227cc)	

## 23. DISASSEMBLY & REASSEMBLY - PU 3000 4 L 53/1



**CAUTION :** Before any work is carried on the pump, stop the machine after carrying out flushing, shut off the compressed air supply and depressurize the circuits triggering the gun.

**The pump is manufactured under the ATEX agreement and can not be modified. KREMLIN REXSON will not be held responsible for any failure to comply with that instruction.**

### ■ MIXER

Unscrew the mixer assembly and replace it with a new one.

### ■ ASI 40 VALVES (REFER TO DOC. 573.062.050)

#### **FLUID PACKING (IND. 22) AND NEEDLE WITH BALL (IND. 37)**

Unscrew the diaphragm (9), the seat-holder assembly (17).

Take off the 2 screws (13).

Disassemble the needle holder (23) from the needle strainer (6) to remove the front body (1) from the gun.

Take off the circlip (26) holding the fluid packing (22).

Remove the fluid packing (22) pulling the needle frontwards.

Unscrew the ball needle (37) from the needle holder (23).

Change the fluid packing and its seal (24).

Clean the front part of the gun.

When assembling, drive fluid packing (22) by pushing it from the front part to the rear part of the body (1) until the packing shoulder comes to lean against the shoulder located inside the gun.

Then, secure the fluid packing by means of the circlip (26).

Reinstall the ball needle (37), the screws (13), the seat-holder assembly (17), the diaphragm (9), the tip and the coupling nut (8).

#### **PISTON ASSEMBLY (IND. 27)**

Unscrew the 4 screws (11).

Remove the spring guide (3) and the cylinder (2).

Take off the spring (7), the spring support (33).

Unscrew the nut (31).

Remove the washer (30) and the piston packing (29).

Clean the parts and change them if necessary.

**Nota :** Before inserting the piston assembly (27) into the cylinder, the packing lip (29) must be shaped by hand as shown opposite (cartridge turned up on the piston).

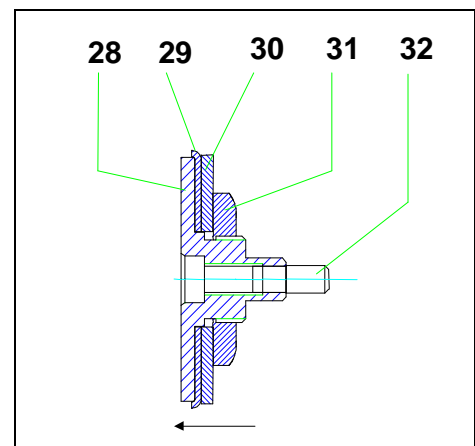

#### **AIR PACKING (IND. 34)**

Take off the back part of the gun and remove the piston as explained before.

Remove the air packing (34).

Replace the packing seal (36) or the air packing assembly.

*Nota :* when changing the ASI 40 valve from the PU 3000 fluid equipment, take off the fittings from the spare valve delivered, then install it on the fluid equipment.

■ FLUID SECTION, MODEL MAJOR 227CC # 105 174 01 07 (BASE & CATALYST)  
(REFER TO DOC. 573.447.050)



**WARNING!**

Before any action on the pump, shut off the compressed air supply and depressurize the systems by triggering the spray gun.

**Guards (air motor cover, coupling shields, housings ...) have been designed for safe use of the equipment.  
The manufacturer will not be held responsible for bodily injury or failure and / or damage to property due to removal or partial removal of the guards.**

**Disassembly of the pump**

- Unscrew the 4 nuts (16) and put aside the flange (1), the tie-rods (14) and the protective housing (4),
- Clamp the pump horizontally through the body (7) with a vice,
- Unscrew the foot valve body assembly (26),
- Take off the piston rod (15) downwards,
- Put aside the cylinder (10).

**Lower valve**

- Unscrew the body of the foot valve body (26),
- Take off the ball cage (19) and the ball (22),
- Take off the seat (23) and the seals (24 & 25).
- Clean all the parts, check them; if there are damaged or worn, change them.

Reinstall the parts in the reverse order of the disassembly sequence.

**Cup seals**

*Nota : the pump body (7) consists of a cartridge (7b) to make easier the changing of the seals.*

- Unscrew the cup nut (5),
- Take off the 10 screws (7d) that tighten the cartridge (7b) in the body (7a),
- Take off the cartridge (7b) screwing the extractors in the 2 M8 holes in the cartridge,
- Take off the washers (6 & 12), and the seals (11),
- Change the seals: PE seals (11b) & PTFE G seals (11d),
- Change the seal (7c).

Clean all the parts, check them; if there are damaged or worn, change them.

Reinstall the parts in the reverse order of the disassembly sequence.

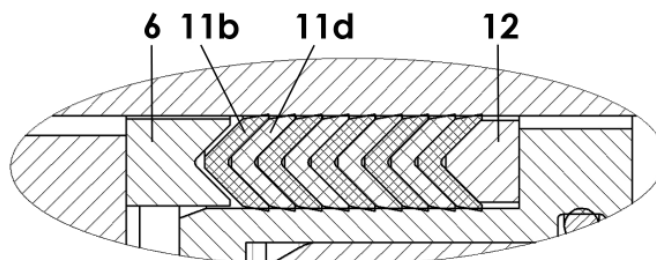
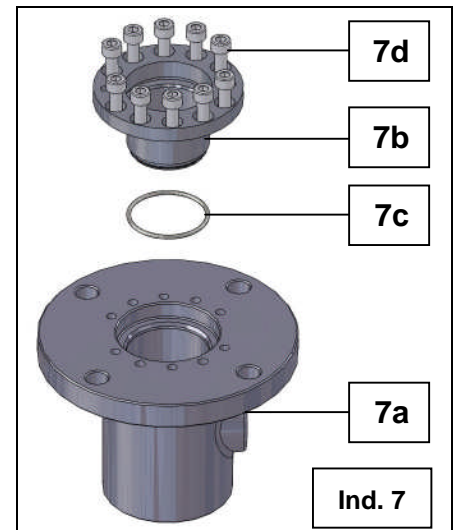



### **Piston rod seals**

- Unscrew the seat (18),
  - Take off the ball (17), the washers (12 & 16), the seals: PE seals (11b) & PTFE G seals (11d) and the adjustment blocks (27),
  - Clean all the parts, check them; if there are damaged or worn, change them.
- Reinstall the parts in the reverse order of the disassembly sequence.

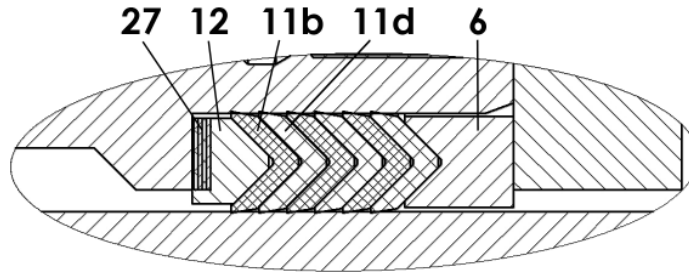

### **Complete assembly of the fluid section**

- Lubricate the cup seals and piston rod seals,
- Slide the piston rod assembly (15) inside the body (7), push it upwards,
- Screw the cylinder (10) into the body (7),
- Screw the foot valve body assembly (26). Tighten slightly,
- Reinstall the protective housing (4), the connecting flange (1) and the tie-rods (14). Screw the 4 nuts (16).
- Couple the fluid section to the pneumatic motor.

#### **Before intervening on the equipment :**

- **Clean the parts with the appropriate cleaning solvent,**
- **Install new seals if necessary after having lubricated them,**
- **Lubricate the piston and the inside of the cylinder to prevent from damaging the seals,**
- **Install new parts if necessary.**

### **Adjustment of the suction valve ball cage screw :**

Depending upon the fluid viscosity to be pumped, adjust the height of the screw (19c) to increase the ball up motion.

Lock the screw on the lock nut (19b).

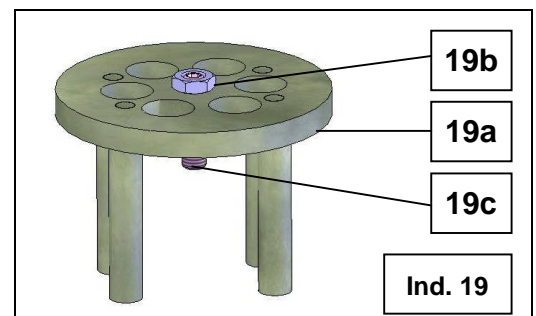

**ASSEMBLY INSTRUCTIONS (FLUID SECTION, MODEL 227CC)**

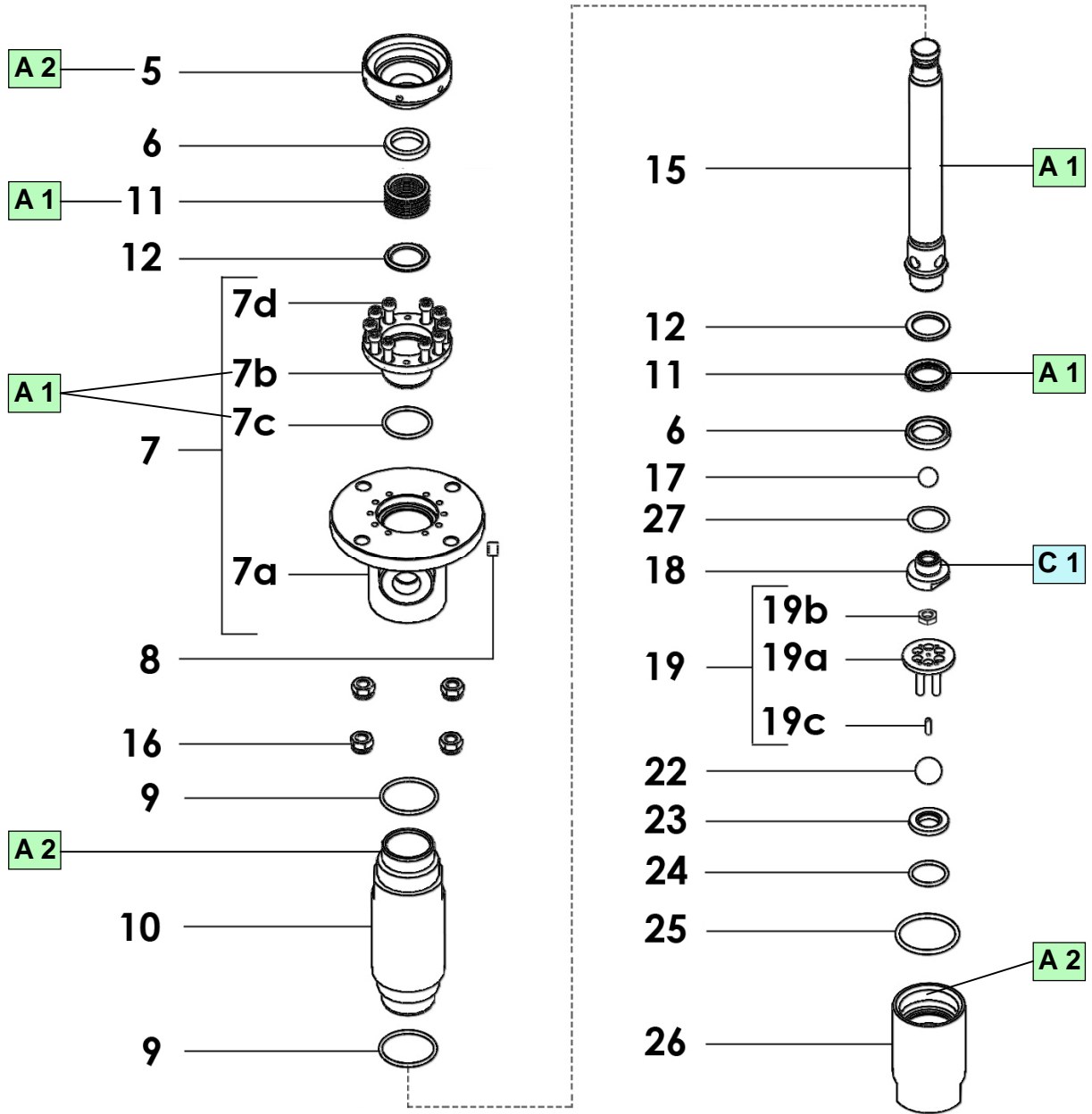

Index	Instruction	Description	Part number
A 1	PTFE grease	PTFE grease (10 ml)	560.440.101
A 2	Anti-seize grease	Grease box (450 g / 99 lb)	560.420.005
C 1	Medium strength Aneorobic Pipe sealant	Loctite 577	-

<b>Doc. 573.404.050</b> Date/Datum/Fecha : 13/03/14 Annule/Cancel/ Ersetzt/Anula : 16/12/13	<b>Modif. / Änderung :</b> Doc. 578.009.110 → 573.437.050 + Ind. / Pos. 24 & 25 Pompe de rinçage / Flushing pump / Spülpumpe / Bomba de limpieza EOS 30-C25 → EOS 02-C85	<b>Pièces de rechange</b> <b>Spare parts list</b> <b>Ersatzteilliste</b> <b>Piezas de repuesto</b>
--	---	---

**MACHINE DE DOSAGE ELECTRONIQUE - ELECTRONIC DOSING MACHINE**  
**ELEKTRONISCHE 2K-ANLAGE - MÁQUINA DE DOSIFICACIÓN ELECTRÓNICA**  
**PU 3000 PNEUMATIQUE / PNEUMATIC / NIEDERDRUCK / NEUMÁTICA**  
**# 155.680.140**

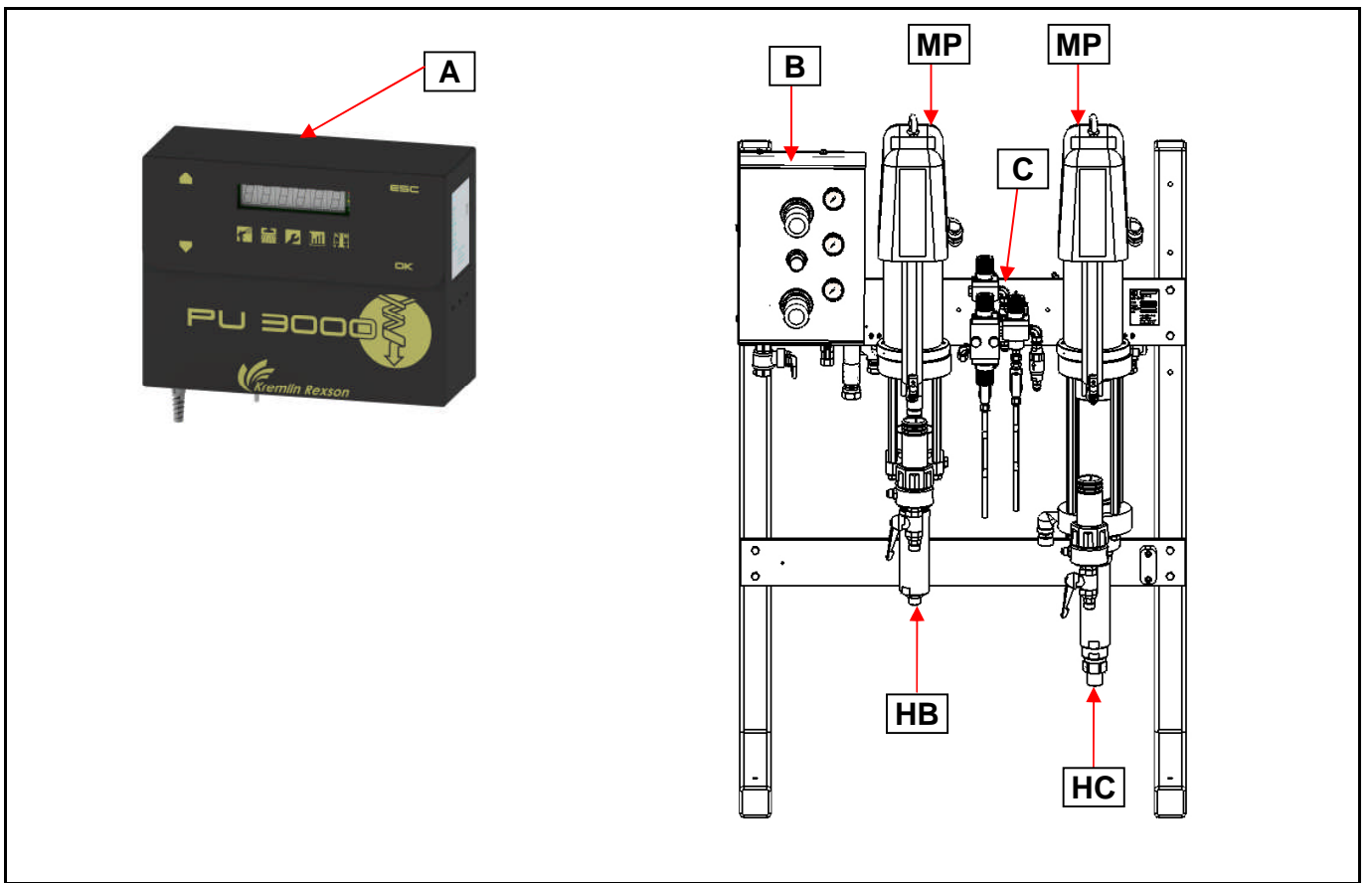

<b>MP</b> Moteur pneumatique / Air motor / Luftmotor / Motor neumático  <b>1500 PU</b>	<b>HB</b> Hydraulique Base / Base fluid section / Basis-Hydraulikteil / Hidráulica Base  <b>50</b>	<b>HC</b> Hydraulique Catalyseur / Catalyst fluid section / Härter-Hydraulikteil / Hidráulica Catalizador  <b>50F</b>
<b># 155.680.078</b> (☞ Doc . 573.437.050)	<b># 144.960.000</b> (☞ Doc . 573.080.050)	<b># 144.960.200</b> (☞ Doc . 573.114.050)

**Option / On request / Optionen / Opción :**

PS : Pompe de rinçage / Flushing pump / Spülpumpe / Bomba de limpieza

<b>A</b>	<b>COFFRET DE COMMANDE / CONTROL CABINET / STEUERUNGSGEHÄUSE / ARMARIO DE MANDO # 155.680.040</b>
----------	---

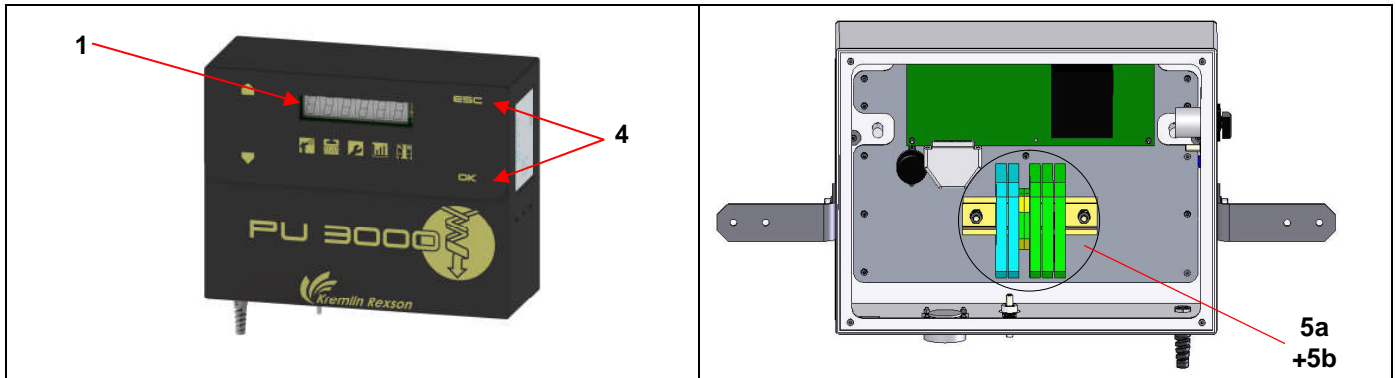

Ind	#	Désignation	Description	Bezeichnung	Denominación	Qté
*1	155 680 048	Carte $\mu$ avec afficheur	$\mu$ card with display unit	Elektronische Karte mit integriertem Display	Carta $\mu$ con visualizador	1
-	901 280 192	Interrupteur	Switch	Schalter	Interruptor	1
*4	155 660 925	Ensemble capteur et aimant	Sensor and magnet assembly	Sensor und Magnet Einheit	Conjunto captador y imán	4
5a	903 050 530	Barrière Zener Z 728	Z 728 Zener barrier	Zener Barriere Z 728	Barrera Zener, tipo Z 728	3
5b	903 050 531	Barrière Zener Z 764	Z 764 Zener barrier	Zener Barriere Z 764	Barrera Zener, tipo Z 764	2
-	901 280 193	Buzzer 24V - 100 db	Buzzer 24V - 100 db	Summer 24V - 100 dB	Sirena 24V - 100 db	1

<b>B</b>	<b>EQUIPEMENT D'AIR / AIR SUPPLY / LUFTAUSRÜSTUNG / EQUIPO DE AIRE</b>
----------	--

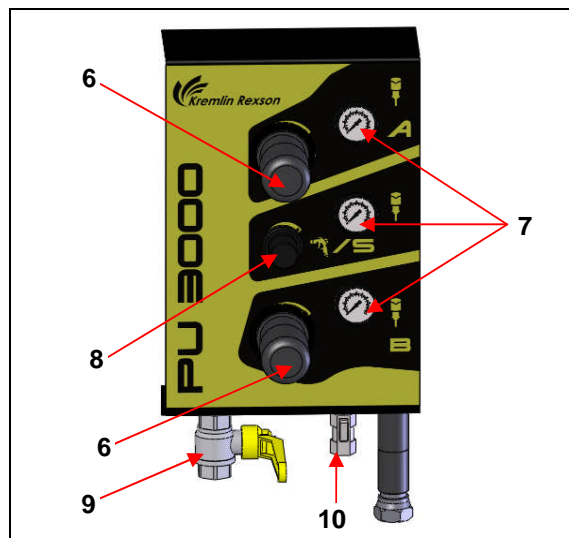

Ind	#	Désignation	Description	Bezeichnung	Denominación	Qté
*6	91 530	Régulateur d'air	Air regulator	Druckminderer	Manorreductor de aire	2
*7	910 011 205	Manomètre 0-10 bar	Gauge, 0-10 bar/145 psi	Manometer, 0-10 bar	Manómetro, tipo 0-10 bar	3
*8	903 130 601	Régulateur d'air	Air regulator	Druckminderer	Manorreductor de aire	1
9	91 458	Vanne FF 3/4" G à décompression	Valve, model FF 3/4" G	Absperrhahn IG 3/4" G	Grifo, tipo HH 3/4" G	1
10	903 090 806	Vanne F 1/4" G	Valve, model F 1/4" G	Absperrhahn IG 1/4" G	Grifo, tipo H 1/4" G	2

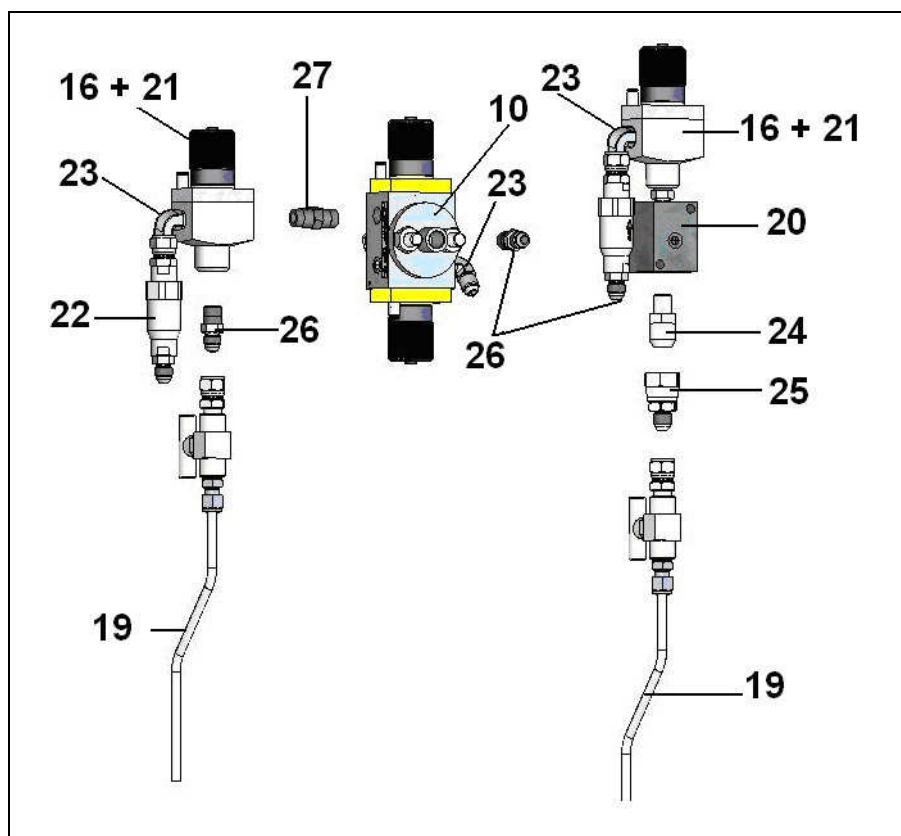
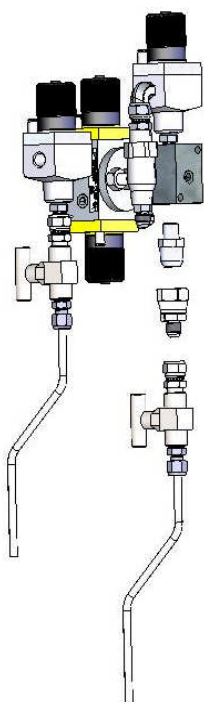

Doc. 573.187.050 & 573.188.050

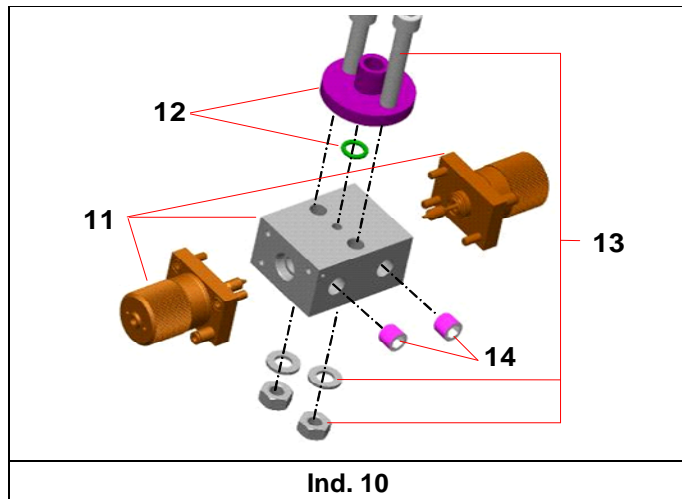

Ind. 10

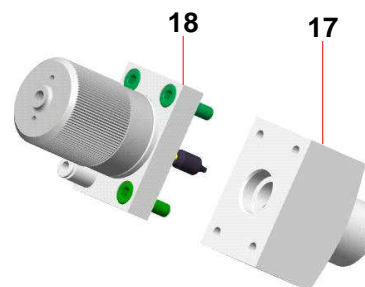

Ind. 16

Ind	#	Désignation	Description	Bezeichnung	Denominación	Qté
10	-	Changeur de teintes	Color changer	Farbwechselblock	Cambiador de colores	1
11	155 535 350	▪ Module d'extrémité AIRMIX® 200 bar	▪ Airmix® end module 200 bar / 2900 psi	▪ Unteres Modul 200 bar	▪ Modulo AIRMIX® de extremidad 200 bar	1
12	155 535 500	▪ Bride de sortie équipée	▪ Outlet flange assembly	▪ Ausgangsflansch, kpl	▪ Brida de salida equipada	1
13	155 535 610	▪ Ensemble 2 tirants	▪ Set of 2 tie-rods	▪ Verdinunsbolzen (Satz mit 2 Stück)	▪ Conjunto de 2 tirantes	1
14	906 314 211	▪ Bouchon 1/4 " G	▪ Plug, model 1/4" G	▪ Blindstopfen 1/4" G	▪ Tapón, tipo 1/4" G	2

Ind	#	Désignation	Description	Bezeichnung	Denominación	Qté
*16	155 528 000	Clapet 200 bar	Valve, 200 bar / 2900 psi	Ventil 200 bar	Válvula 200 bar	1
17	055 528 001	▪ Corps	▪ Body	▪ Körper	▪ Cuerpo	1
*18	155 535 315	▪ Vanne AIRMIX® 200 bar (Doc. 573.188.050)	▪ AIRMIX® valve, 200 bar / 2900 psi (Doc. 573.188.050)	▪ AIRMIX®-Ventil 200 bar (Dok. 573.188.050)	▪ Válvula AIRMIX® 200 bar (Doc. 573.188.050)	1
*19	155 680 025	Ensemble robinet- pointeau	Needle-valve assembly	Nadelventil-Einheit	Conjunto grifo-válvula	2
20	055 660 070	Bloc d'injection	Injection unit	Injektions-Block	Bloque de inyección	1
21	055 528 002	Bouchon pour clapet	Plug for valve	Blindstopfen für Ventil	Tapón para válvula	2
*22	903 160 510	Clapet AR inox 200 bar	Non return valve, stainless steel, 200 bar / 2900.6 psi	Rückschlagventil, Edelstahl, 200 bar	Válvula AR de inox, 200 bar	2
23	905 210 602	Raccord coudé inox (M 1/4 NPT - M 1/2 JIC)	Elbow fitting, stainless steel (male 1/4 NPT - male # 5 JIC)	Winkelnippel, Edelstahl (AG 1/4 NPT - AG 1/2 JIC)	Racore acodado inox (M 1/4 NPT - M 1/2 JIC)	3
24	905 210 512	Raccord produit droit M 1/4 G - M 3/4 JIC	Straight fluid fitting (M 1/4 NPT - # 8 JIC)	Gewindenippel (AG 1/4 NPT - AG 3/4 JIC)	Racor recto producto (M 1/4 NPT - M 3/4 JIC)	1
25	905 160 219	Raccord inox M 1/2 JIC - F 3/4 JIC	Fitting, stainless steel, model # 5 JIC - # 8 JIC	Drehanschluss aus Edelstahl, AG 1/2 JIC - IG 3/4 JIC	Racor de inox, tipo M 1/2 JIC - H 3/4 JIC	1
26	906 314 217	Raccord inox M 3/4 JIC - M 1/2 JIC	Fitting, stainless steel, model double male, # 8 JIC - # 5 JIC	Anschluss aus Edelstahl, AG 3/4 JIC - AG 1/2 JIC	Racor de inox, tipo M 3/4 JIC - M 1/2 JIC	3
*-	155 660 080	Ensemble mélangeur souple (1m - 375 bar)	Flexible mixer assembly (1 m - 375 bar / 5440 psi)	Mischer-Schlauch mit Anschlüssen (1m - 375 bar)	Conjunto mezclador flexible (1m - 375 bar)	1
*-	050 450 106	Tuyau produit (Ø 4,8 mm, long. 0,6 m, raccords inox, 240 bar)	Fluid hose (3/16" dia, 0,6 m long, stainless steel hoses, 240 bar / 3481 psi)	Materialschlauch (Ø 4,8 mm, Länge : 0,6 m, Anschlüsse Edelstahl, 240 bar)	Tubería producto (Ø 4.8 mm, 0.6 m de largo, racores de inox, 240 bar)	3
*-	050 452 010	Tuyau CATA (PTFE, Ø 4,8 mm, long. 0,6 m, raccords inox, 240 bar)	CATA hose (PTFE, 3/16" dia, 0,6 m long, stainless steel hoses, 240 bar / 2481 psi)	Härter Schlauch (PTFE, Ø 4,8 mm, Länge : 0,6 m, Anschlüsse Edelstahl, 240 bar)	Tubería CATA (PTFE, Ø 4.8 mm, 0.6 m de largo, racores de inox, 240 bar)	2
-	049 596 110	Canne d'aspiration inox Ø 25 avec crépine	Suction rod (stainless steel), Ø 25 with strainer	Saugschlauch, Edelstahl Ø 25 mit Siebkorb	Caña de aspiración de inox Ø 25 con piña	2
*-	149 591 400	▪ Crépine avec manchon	▪ Strainer with sleeve	▪ Siebkorb	▪ Piña con manguito	2
-	155 580 400	Filtre Airless® inox 3/8 (Doc. 573.299.050)	AIRLESS filter model 3/8, stainless steel (Doc. 573.299.050)	AIRLESS® Filter 3/8, Edelstahl (Dok. 573.299.050)	Filtro AIRLESS® de inox 3/8 (Doc. 573.299.050)	2
-	049 596 000	Canne de purge inox	Drain rod, stainless steel	Entleerungsschlauch, Edelstahl	Caña de purga de inox	2
-	910 090 101	Eprouvette (2 Litres)	Beaker (2 liters / 0.53 US gal)	Messzylinder (2 Liter)	Probeta (2 litros)	2
-	903 050 541	Electrovannes ATEX 24V	Electrovalves, ATEX 24V	Elektroventile, ATEX 24V	Electroválvulas ATEX 24V	2
-	903 050 529	Electrovannes ATEX	ATEX electrovalves	ATEX Elektroventile	Electroválvulas ATEX	3
-	901 180 024	Câble de mise à la terre (Lg. 5m) avec rondelle et vis	Cable ground (5 m / 197" length) with washer and screw	Erdungskabel (5 m) mit Scheibe und Schraube	Cable de puesta a tierra (5m de largo) con arandela y tornillo	1

## ACCESSOIRES - ACCESSORIES - ZUBEHÖR - ACCESORIOS

Ind	#	Désignation	Description	Bezeichnung	Denominación	Qté
-	149 990 020	Flacon de lubrifiant T (125 ml)	T lubricant (125 ml / 4.4 oz)	Spülmittel "T" (125 ml)	Recipiente de lubricante T (125 ml)	1
-	044 950 008	Clé pour cuve presse-garniture	Wrench for wetting-cup	Schlüssel für Spülmitteltasse	Llave para prensa-estopa	1

# 044.950.008



### REGULATEUR PILOTÉ BP / LP PILOTED FLUID REGULATOR ND MATERIAL-DRUCKREGLER LUFTGESTEUERT / REGULADOR PILOTADO BP

**Mod. : 40 - 0 / 6 bar # 155.610.520**

↪ Doc. 573.203.110 & 573.415.050

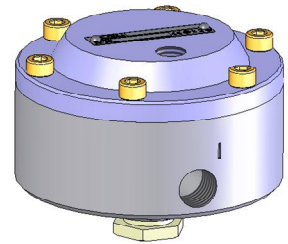

## OPTION - ON REQUEST - OPTIONEN - OPCIÓN

**PS**

Ind. / Pos. 24

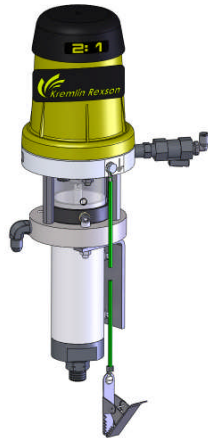

Ind. / Pos. 25

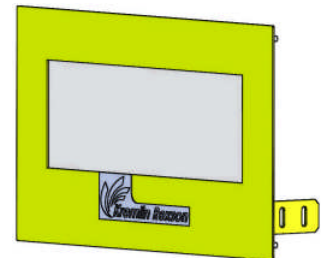

Ind	#	Désignation	Description	Bezeichnung	Denominación	Qté
24	155 680 170	Pompe de rinçage pour pompe PU 3000, modèle EOS 02-C85 (Doc. 573.457.050)	Flushing pump for PU 3000 pump, model EOS 02-C85 (Doc. 573.457.050)	Spülpumpe für 2-K-Anlage PU 3000, Modell EOS 02-C85 (Dok. 573.457.050)	Bomba de limpieza para bomba PU 3000, tipo EOS 02-C85 (Doc. 573.457.050)	1
25	155 660 340	Kit commande en cabine	Booth control kit	Set für Kabinensteuerung	Kit mando en cabina	1
-	149 990 020	Flacon de lubrifiant T (125 ml)	T lubricant (125 ml / 4.4 oz)	Spülmittel « T » (125 ml)	Recipiente de lubricante T (125 ml)	1

\* Pièces de maintenance préconisées.

\* Preceding the index number denotes a suggested spare part.

\* Bezeichnete Teile sind empfohlene Ersatzteile.

\* Piezas de mantenimiento preventivas.

N C : Non commercialisé.

N S : Denotes parts are not serviceable.

N S : Bezeichnete Teile gibt es nicht einzeln, sondern nur komplett.

N S : no suministrado.

<p><b>Doc. 573.437.050</b>  Date/Datum/Fecha : 13/01/14  Annule/Cancel/  Ersetzt/Anula :  Doc. 578.009.110</p>	<p><b>Modif. / Änderung :</b></p>	<p><b>Pièces de rechange</b>  <b>Spare parts list</b>  <b>Ersatzteilliste</b>  <b>Piezas de repuesto</b></p>
--	-----------------------------------	--

**PU 3000 : MOTEUR A AIR / AIR MOTOR / LUFTMOTOR / MOTOR DE AIRE**  
**Mod. 1500 # 155.680.078**

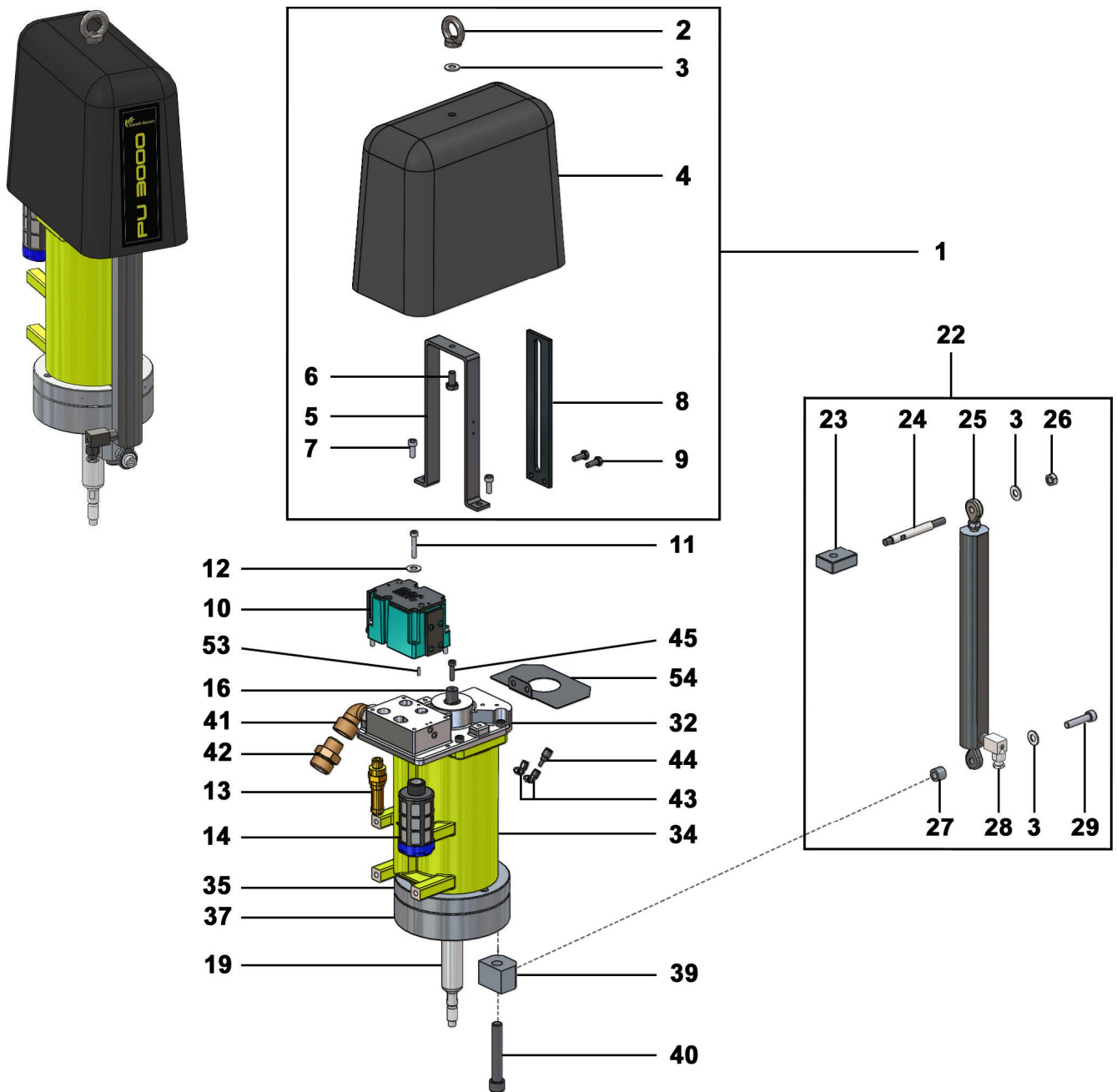



**Détails - Details - Einzelheiten - Detalles**

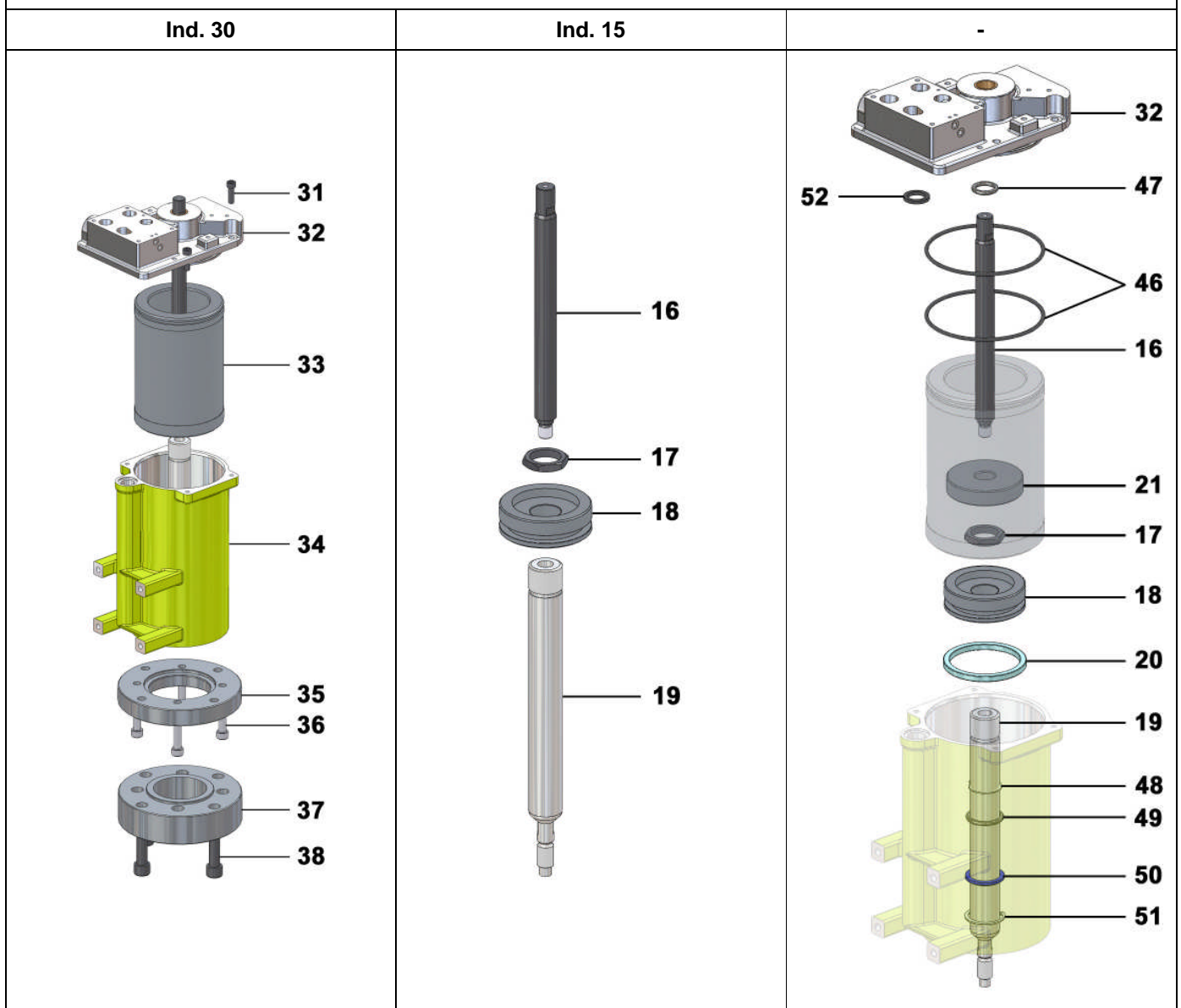

Ind	#	Désignation	Description	Bezeichnung	Denominación	Qté
*1	055 680 076	Ensemble capot	Cover assembly	Haube, kpl. Einheit	Conjunto tapa	1
2	91 421	▪ Anneau de levage	▪ Hoisting ring	▪ Ringschraube	▪ Anillo de sujeción	1
3	963 040 019	▪ Rondelle MU 8	▪ Washer, model MU 8	▪ Scheibe, MU 8	▪ Arandela, tipo MU 8	1
4	NC / NS	▪ Capot	▪ Cover	▪ Haube	▪ Capó	1
5	210 286	▪ Etrier	▪ U-Bolt	▪ Halterung	▪ Tirante	1
6	933 011 198	▪ Vis HM 8 x 16	▪ Screw, model HM 8 x 16	▪ Schraube, HM 8 x 16	▪ Tornillo, tipo HM 8 x 16	1
7	933 151 196	▪ Vis CHc M 6 x 16	▪ Screw, model CHc M 6 x 16	▪ Schraube, CHc M 6 x 16	▪ Tornillo, tipo CHc M 6 x 16	2
8	055 680 008	▪ Guide pour capteur	▪ Guide for sensor	▪ Potentiometer Führung	▪ Guía para captador	1
9	NC / NS	▪ Vis HM 6 x 16	▪ Screw, model HM 6 x 16	▪ Schraube, HM 6 x 16	▪ Tornillo, tipo HM 6 x 16	2

Ind	#	Désignation	Description	Bezeichnung	Denominación	Qté
*10	146 310 092	Distributeur 4/2	Distributor, model 4/2	4/2 Wege Pneum. Ventil	Distribuidor, tipo 4/2	1
11	NC / NS	Vis CHc M 5 x 30	Screw, model CHc M 5 x 30	Schraube, CHc M 5 x 30	Tornillo, tipo CHc M 5 x 30	4
12	NC / NS	Rondelle WZ 5	Washer, model WZ 5	Scheibe, WZ 5	Arandela, tipo WZ 5	4
*13	903 080 401	Soupape de sécurité	Safety valve	Sicherheitsventil	Válvula de seguridad	1
*14	146 310 092	Silencieux	Muffler	Schalldämpfer	Silenciador	1
<b>*15</b>	<b>055 680 077</b>	<b>Ensemble tige de piston</b>	<b>Piston rod assembly</b>	<b>Kolbenstangen Einheit</b>	<b>Conjunto eje pistón</b>	<b>1</b>
16	210 443	▪ Tige d'inversion	▪ Reversing rod	▪ Umsteuerstange	▪ Eje de inversión	1
17	210 442	▪ Erou	▪ Nut	▪ Mutter	▪ Tuerca	1
18	NC / NS	▪ Piston	▪ Piston	▪ Kolben	▪ Pistón	1
19	055 680 011	▪ Tige de piston	▪ Piston rod	▪ Kolbenstange	▪ Eje de pistón	1
20	NC / NS	Joint torique (piston)	O-Ring (piston)	O-Ring Dichtung (Kolben)	Junta tórica (pistón)	1
21	NC / NS	Rondelle de calage	Set ring	Stützscheibe	Arandela	1
<b>*22</b>	<b>055 680 075</b>	<b>Ensemble capteur de déplacement</b>	<b>Movement sensor assembly</b>	<b>Linearpotentiometer Einheit</b>	<b>Conjunto captador de movimiento</b>	<b>1</b>
23	055 680 051	▪ Entrainement capteur	▪ Sensor driving	▪ Potentiometer Mitnehmer	▪ Arrastre captador	1
24	055 680 004	▪ Témoin de course	▪ Stroke detector	▪ Hubanzeiger	▪ Téstigo de recorrido	1
*25	91 519	▪ Capteur de déplacement	▪ Movement sensor	▪ Linearpotentiometer	▪ Captador de movimiento	1
3	963 040 019	▪ Rondelle MU 8	▪ Washer, model MU 8	▪ Scheibe, MU 8	▪ Arandela, tipo MU 8	2
26	953 010 019	▪ Erou HM 8	▪ Nut, model HM 8	▪ Mutter, HM 8	▪ Tuerca, tipo HM 8	1
27	055 680 018	▪ Entretoise	▪ Spacer	▪ Distanzstück	▪ Tirante	1
28	91 517	▪ Connecteur	▪ Connector	▪ Stecker	▪ Conectador	1
29	930 151 446	▪ Vis CHc M 8 x 35	▪ Screw, model CHc M 8 x 35	▪ Schraube, CHc M 8 x 35	▪ Tornillo, tipo CHc M 8 x 35	1
<b>*30</b>	<b>055 680 074</b>	<b>Ensemble corps moteur</b>	<b>Motor body assembly</b>	<b>Luftmotor Körper Einheit</b>	<b>Conjunto cuerpo de motor</b>	<b>1</b>
31	933 151 277	▪ Vis CHc M 6 x 20	▪ Screw, model CHc M 6 x 20	▪ Schraube, CHc M 6 x 20	▪ Tornillo, tipo CHc M 6 x 20	4
32	210 439	▪ Couvercle	▪ Cover	▪ Deckel	▪ Tapa	1
33	NC / NS	▪ Cylindre moteur	▪ Cylinder, air motor	▪ Luftmotorzylinder	▪ Cilindro motor	1
34	209 395	▪ Cylindre	▪ Cylinder	▪ Zylinder	▪ Cilindro	1
35	209 600	▪ Bride liaison	▪ Connecting flange	▪ Verbindungsflansch	▪ Brida conexión	1
36	930 151 446	▪ Vis CHc M 8 x 35	▪ Screw, model CHc M 8 x 35	▪ Schraube, CHc M 8 x 35	▪ Tornillo, tipo CHc M 8 x 35	4
37	055 680 002	▪ Bride accouplement	▪ Coupling flange	▪ Kupplungsflansch	▪ Brida acoplamiento	1
38	88 188	▪ Vis CHc M 12 x 40	▪ Screw, model CHc M 12 x 40	▪ Schraube, CHc M12 x 40	▪ Tornillo, tipo CHc M 12 x 40	3

Ind	#	Désignation	Description	Bezeichnung	Denominación	Qté
39	155 680 016	Support capteur	Sensor support	Potentiometer Halterung	Soporte captador	1
40	NC / NS	Vis CHc M 12 x 75	Screw, model CHc M 12 x 75	Schraube, CHc M 12 x 75	Tornillo, tipo CHc M 12 x 75	1
41	NC / NS	Coude MF 1/2"	Elbow, model MF 1/2"	Winkelnippel, AG/IG 1/2"	Codo, tipo MH 1/2"	1
42	050 102 401	Raccord M 3/4" NPS - M 1/2" G	Fitting, model double male, 3/4" NPS - 1/2" G	Anschluss AG 3/4" NPS - AG 1/2" G	Racor, tipo M 3/4" NPS - M 1/2" G	1
43	552 260	Raccord coudé M5	Elbow fitting, model M5	Winkelnippel, M5	Racor acodado, tipo M5	2
44	905 120 945	Grossisseur T 4 x 6	Adapter T 4 x 6	Red. Stecknippel 4 x 6	Ampliación T 4 x 6	1
45	88 123	Vis CHc M 5 x 20	Screw, model CHc M 5 x 20	Schraube, CHc M 5 x 20	Tornillo, tipo CHc M 5 x 20	1
46	NC / NS	Joint torique	O-Ring	O-Ring Dichtung	Junta tórica	2
47	NC / NS	Joint	Seal	Dichtung	Seal	1
48	NC / NS	Circlips	Ring	Sicherungsring	Anillo truarc	1
49	NC / NS	Joint NBR	NBR seal	NBR Dichtung	Junta NBR	1
50	NC / NS	Joint raclleur	Scraper seal	Abstreifring	Junta rascadora	1
51	NC / NS	Circlips	Ring	Sicherungsring	Anillo truarc	1
52	NC / NS	Joint plat	Flat seal	Flachdichtung	Junta plana	1
53	NC / NS	Goupille	Pin	Splint	Pasador	1
54	NC / NS	Plaque complément de capot	Cover plate complement	Führungsplatte für Haube	Placa complemento de capó	1

Ind	#	Désignation	Description	Bezeichnung	Denominación	Qté
*	105 783	<b>Pochette de joints moteur (Ind. 20, 46, 47, 48, 49, 50, 51, 52)</b>	<b>Seal kit air motor (Ind. 20, 46, 47, 48, 49, 50, 51, 52)</b>	<b>Dichtungssatz für Luftmotor (Pos. 20, 46, 47, 48, 49, 50, 51, 52)</b>	<b>Bolsa de juntas motor (Índ. 20, 46, 47, 48, 49, 50, 51, 52)</b>	1

\* Pièces de maintenance préconisées.

\* Preceding the index number denotes a suggested spare part.

\* Bezeichnete Teile sind empfohlene Ersatzteile.

\* Piezas de mantenimiento preventivas.

N C : Non commercialisé.

N S : Denotes parts are not serviceable.

N S : Bezeichnete Teile gibt es nicht einzeln, sondern nur  
komplett.

N S : no suministrado.

<b>Doc. 573.080.050</b> Date/Datum/Fecha : 11/10/11 Annule/Cancel/ Ersetzt/Anula : 21/04/05	<b>Modif. /Änderung :</b> Mise à jour / Update / Aktualisierung / Actualización	<b>Pièces de rechange</b> <b>Spare parts list</b> <b>Ersatzteilliste</b> <b>Piezas de repuesto</b>
--	---	---

<b>HYDRAULIQUE, modèle 50</b> <b>(garniture mobile avec joint GT)</b>	<b>FLUID SECTION, model 50</b> <b>(mobile packing with GT seal)</b>	<b>#</b>
<b>HYDRAULIKTEIL, Modell 50 (mobile</b> <b>Packung mit GT-Dichtungsring)</b>	<b>HIDRÁULICA, tipo 50</b> <b>(guarnición móvil con junta GT)</b>	<b>144.960.000</b>

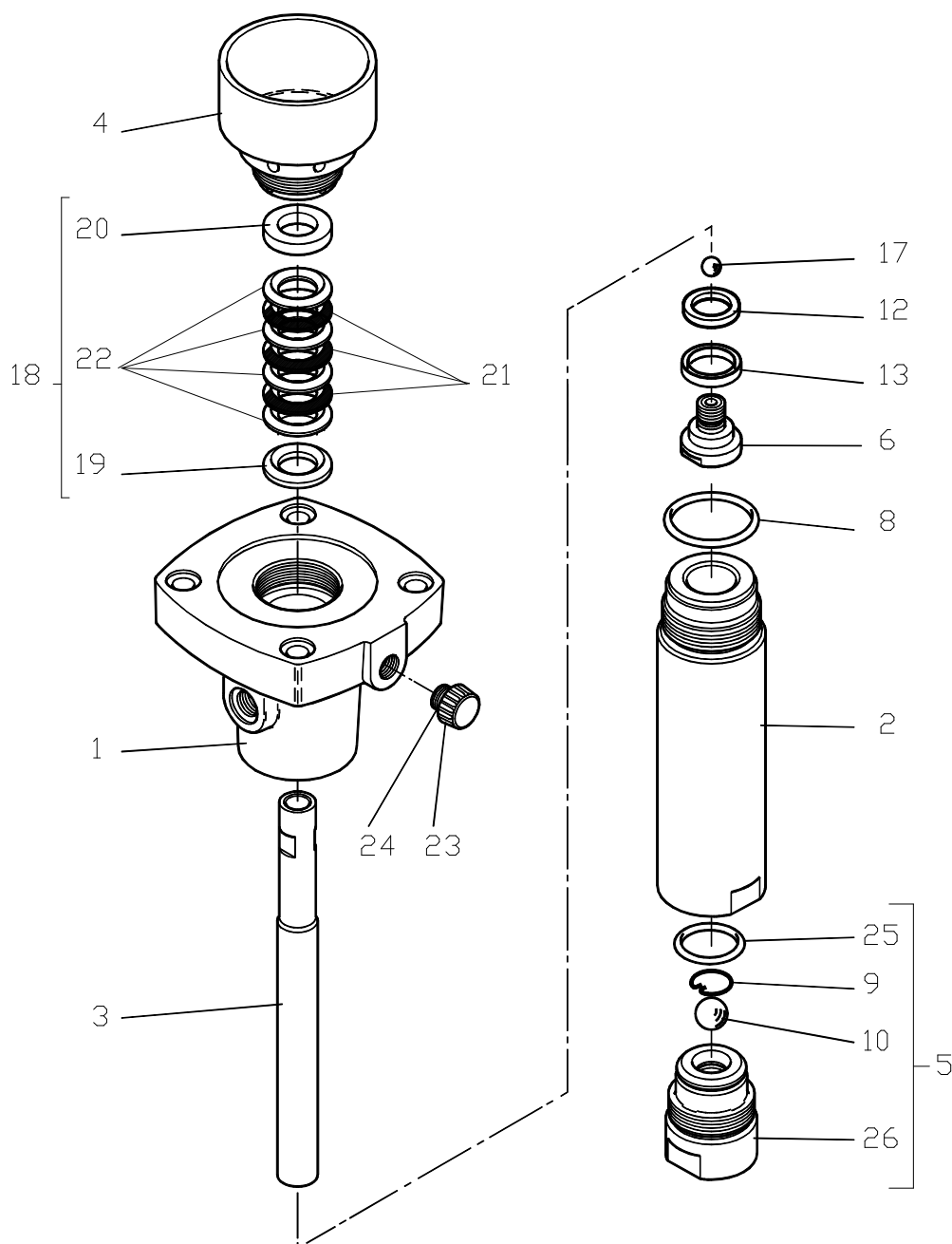

**Hydraulique avec joint GT (à partir de la pompe N° série : 905 600)**  
**Fluid section with GT seal (from pump serie N°: 905 600)**  
**Hydraulikteil mit GT-Dichtungsring (ab Pumpe Serien-Nr. 905.600)**  
**Hidráulica con junta GT (a partir de la bomba con el N° de serie : 905 600)**

Ind	#	Désignation	Description	Bezeichnung	Denominación	Qté
1	044.960.001	Bride supérieure	Upper flange	oberer Flansch	Brida superior	1
* 2	044.960.002	Cylindre	Cylinder	Materialzylinder	Cilindro	1
* 3	044.960.003	Piston	Piston	Materialkolben	Pistón	1
4	044.950.004	Cuve presse-garniture	Wetting-cup	Spülmitteltasse	Cubeta prensa-guarnición	1
<b>5</b>	<b>044.950.010</b>	<b>Clapet d'aspiration assemblé</b>	<b>Suction valve assembly</b>	<b>Ansaugventil, komplett</b>	<b>Válvula aspiración completa</b>	<b>1</b>
9	044.550.029	▪ Jonc	▪ Rush	▪ Sicherungsring	▪ Anillo de retención bola	1
10	907.414.242	▪ Bille Ø 16, inox 440C	▪ Ball Ø 16 (5/8 "), stainless steel 440C	▪ Kugel, Ø 16, Edelstahl 440C	▪ Bola Ø 16 de inox 440C	1
25	050.040.318	▪ Joint torique	▪ O Ring	▪ O-Ring	▪ Junta O Ring	1
26	NCS / NSS	▪ Corps de clapet	▪ Valve body	▪ Saugventil	▪ Cuerpo de válvula	1
6	044.960.215	Clapet de refoulement	Exhaust valve	Druckventil	Válvula de expulsión	1
8	050.040.317	Joint torique	O Ring	O-Ring	Junta O Ring	1
12	044.960.204	Rondelle GT	Washer GT	Scheibe, GT	Arandela GT	1
13	909.150.215	Joint GT inférieur (garniture mobile)	Seal GT lower (mobile packing)	GT Dichtung (mobile Packung)	Junta GT inferior (guarnición móvil)	1
17	907.414.223	Bille Ø 9,52, inox 440C	Ball Ø 9,52 (3/8 "), stainless steel 440C	Kugel, Ø 9,52, Edelstahl 440C	Bola Ø 9,52 de inox 440C	1
<b>18</b>	<b>-</b>	<b>Garniture supérieure</b>	<b>Upper packing</b>	<b>Obere Packung</b>	<b>Guarnición superior</b>	<b>1</b>
19	044.960.011	▪ Bague male, inox	▪ Male ring, stainless steel	▪ Unterer Stützring, Edelstahl	▪ Anillo macho, inox	1
20	044.960.012	▪ Bague femelle, inox	▪ Female ring, stainless steel	▪ Oberer Stützring, Edelstahl	▪ Anillo hembra, inox	1
21	909.050.913	▪ Joint chevron, polyfluid	▪ Chevron seal, polyfluid	▪ Packungsring, Polyfluid	▪ Junta chevrón, polifluida	3
22	109.050.818	▪ Joint chevron, PTFEG (pochette de 10)	▪ Chevron seal, PTFEG (pack of 10)	▪ Packungsring, PTFEG (10 St.)	▪ Junta chevrón, PTFEG (bolsa de 10)	4
23	144.950.012	Bouchon de vidange	Drain plug	Ablafschraube	Tapón de vaciado	1
24	109.020.401	▪ Joint plat (x 5)	▪ Flat seal (x 5)	▪ Flachdichtung (5 Stück)	▪ Junta plana (bolsa de 5)	1

Ind	#	Accessoires	Accessories	Zubehör	Accesorios	
31	044.950.008	Clé pour cuve presse-garniture	Wrench for wetting-cup	Schlüssel für Spülmittel-tasse	Llave para prensaestopa	1
-	149.990.020	Flacon de lubrifiant T (1/4 de litre)	T lubricant (1/4 liter)	Spülmittel T (1/4 Ltr)	Botella de lubricante T (1/4 de litro)	1

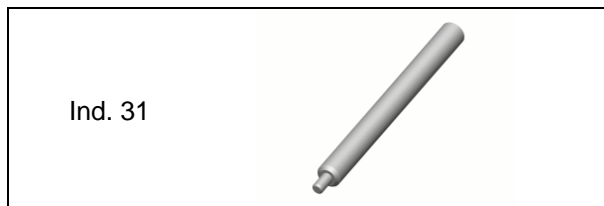

Ind	#	Désignation	Description	Bezeichnung	Denominación	Qté
*	144.960.091	Pochette de joints (ind. 8, 9, 10, 13, 17, 21, 22, 24, 25)	Package of seals (ind. 8, 9, 10, 13, 17, 21, 22, 24, 25)	Dichtungssatz für Hydraulikteil (beinhaltet Pos. 8, 9, 10, 13, 17, 21, 22, 24, 25)	Bolsa de juntas (ind. 8, 9, 10, 13, 17, 21, 22, 24, 25)	1
*	144.960.096	Pochette de maintenance (ind. 5, 6, 12 + pochette de joints)	Servicing kit (ind. 5, 6, 12 + package of seals)	Servicekit für Hydraulikteil (beinhaltet Pos. 5, 6, 12 und den Dichtungssatz)	Bolsa de mantenimiento (ind. 5, 6, 12 + bolsa de juntas)	1

\* Pièces de maintenance préconisées tenues en stock.

\* Preceding the index number denotes a suggested spare part.

\* Bezeichnete Teile sind empfohlene Ersatzteile.

\* Piezas de mantenimiento preventivas a tener en stock.

N C S : Non commercialisé seul.

N S S : Denotes parts are not serviceable separately.

N S S : bezeichnete Teile gibt es nicht einzeln, sondern nur komplett.

N S S : no suministrado por separado.

		EN OPTION :	OPTIONAL :	OPTION :	OPCIÓN :	
Ind	#	Désignation	Description	Bezeichnung	Denominación	Qté
10	907.414.142	Bille Ø 16 inox 316	Ball Ø 16 (316 stainless steel)	Kugel (Edelstahl), Ø 16, 316	Bola Ø 16 de inox 316	1
17	907.414.123	Bille Ø 9,52 inox 316	Ball Ø 9,52 (316 stainless steel)	Kugel (Edelstahl), Ø 9,52, 316	Bola Ø 9,52 de inox 316	1
18	144.960.100	Cartouche supérieure avec joint GT	Upper packing with GT seal	Obere Packung, GT - Dichtung	Cartucho superior con junta GT	1
22	909.051.105	Joint chevron, PE	Chevron seal, PE	Packungsring, PE	Junta chevrón, PE	4

<b>OPTION : Pièces spécifiques pour garniture mobile avec joints chevrons</b>	<b>OPTION : specific parts for mobile packing with chevron seals</b>
<b>OPTION : Spezielle Teile für mobile Packung mit Packungsringen</b>	<b>OPCIÓN : partes específicas para guarnición móvil con juntas de chevrón</b>

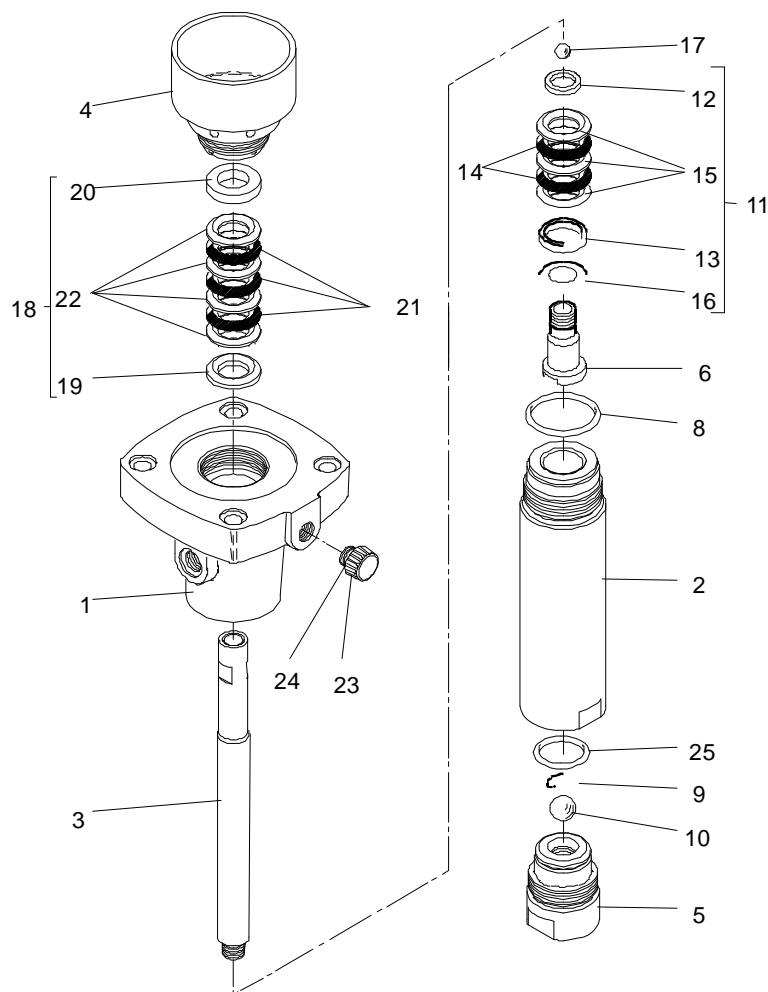

Ind	#	Désignation	Description	Bezeichnung	Denominación	Qté
6	044.960.010	Clapet de refoulement	Exhaust valve	Druckventil	Válvula de expulsión	1
12	044.960.007	Rondelle male, inox	Male washer, stainless steel	Scheibe, außen, Edelstahl	Arandela macho, inox	1
13	044.960.008	Rondelle femelle, inox	Female washer, stainless steel	Scheibe, innen, Edelstahl	Arandela hembra, inox	1
14	909.050.819	Joint chevron, PTFEG	Chevron seal, PTFEG	Packungsring, PTFEG	Junta chevrón, PTFEG	2
15	909.051.106	Joint chevron, PE	Chevron seal, PE	Packungsring, PE	Junta chevrón, PE	3
16	044.960.009	Rondelle de calage, inox (facultative)	Set ring, inox (optional)	Stützscheibe, Edelstahl (fakultativ)	Arandela, inox (facultativa)	1
-	144.960.090	Pochette de joints (ind. 8, 9, 10, 14, 15, 16, 17, 21, 22, 24, 25)	Package of seals (ind. 8, 9, 10, 14, 15, 16, 17, 21, 22, 24, 25)	Dichtungssatz (beinhaltet Pos. 8, 9, 10, 14, 15, 16, 17, 21, 22, 24, 25)	Bolsa de juntas (ind. 8, 9, 10, 14, 15, 16, 17, 21, 22, 24, 25)	1
-	144.960.095	Pochette de maintenance (ind. 5, 6 + pochette de joints)	Servicing kit (ind. 5, 6 + package of seals)	Servicekit für Hydraulikteil (beinhaltet Pos. 5, 6 und den Dichtungssatz )	Bolsa de mantenimiento (ind. 5, 6 + bolsa de juntas)	1

<b>Doc. 573.114.050</b> Date/Datum/Fecha : 10/10/11 Annule/Cancel/ Ersetzt/Anula : 10/06/02	<b>Modif. /Änderung :</b> Mise à jour / Update / Aktualisierung / Actualización	<b>Pièces de rechange</b> <b>Spare parts list</b> <b>Ersatzteilliste</b> <b>Piezas de repuesto</b>
--	---	---

<b>HYDRAULIQUE FLOWMAX ®,</b> <b>modèle 50 F</b>	<b>FLOWMAX ® FLUID SECTION,</b> <b>model 50 F</b>	<b>#</b>
<b>FLOWMAX ® HYDRAULIKTEIL,</b> <b>Modell 50 F</b>	<b>HIDRÁULICA FLOWMAX ®,</b> <b>tipo 50 F</b>	<b>144.960.200</b>

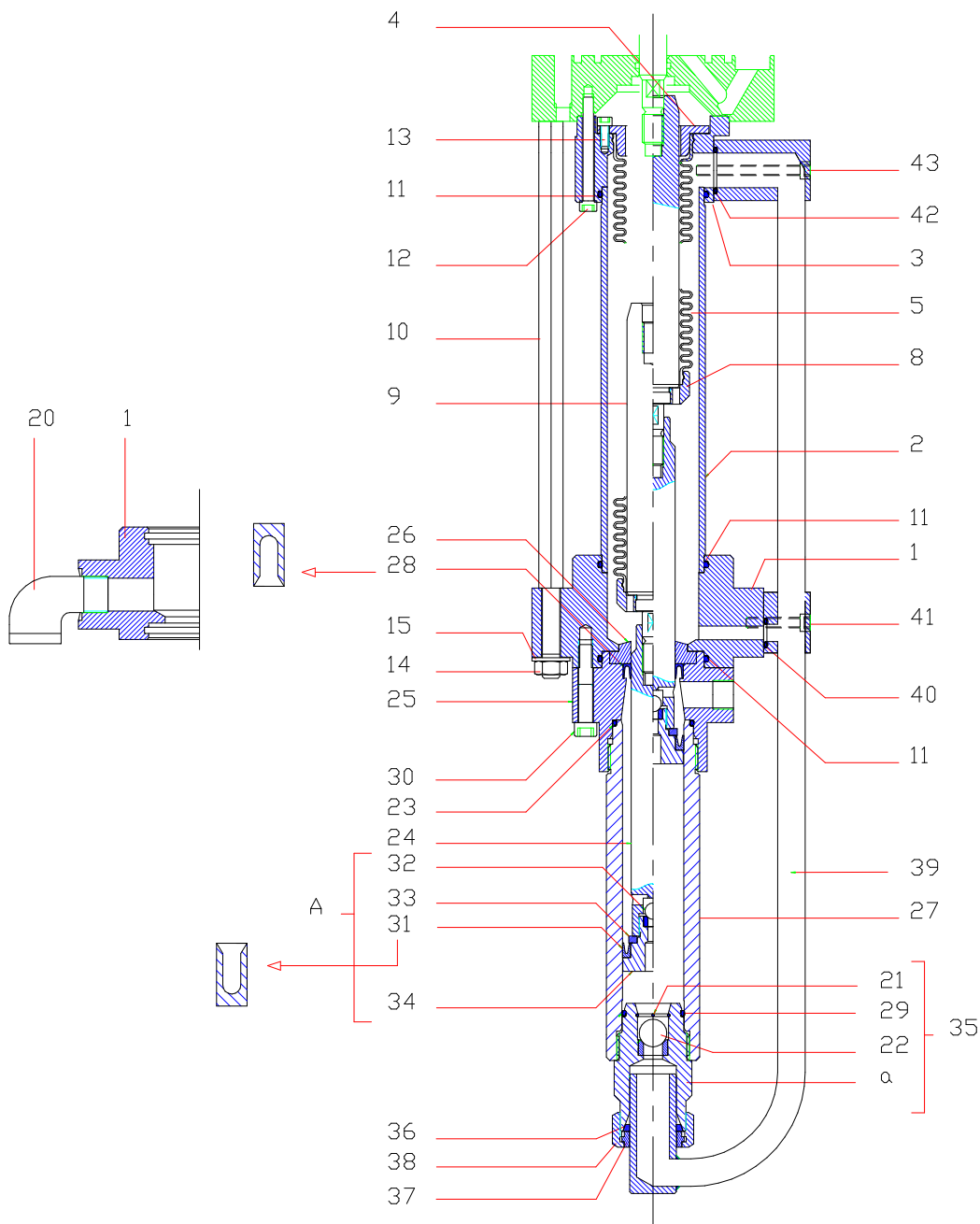



Ind	#	Désignation	Description	Bezeichnung	Denominación	Qté
1	044.970.451	Bride d'aspiration	Suction flange	Unterer Flansch	Brida de aspiración	1
2	044.970.052	Cylindre	Cylinder	Ansaugzylinder	Cilindro	1
3	044.970.445	Palier d'aspiration	Suction bearing	Oberer Flansch	Palier de aspiración	1
4	044.970.046	Bride soufflet	Flange, bellows	Faltenbalg-Flansch	Brida fuelle	1
* 5	044.970.055	Soufflet	Bellows	Faltenbalg	Fuelle	1
8	044.970.047	Jupe	Skirt	Klemmstück	Faldón	1
9	044.970.049	Piston intermédiaire	Piston, intermediate	Zwischenkolben	Pistón intermediario	1
10	044.970.060	Tirant d'accouplement	Coupling rod	Steuerstange	Tirante de acoplamiento	4
11	050.040.323	Joint PTFE	Seal, PTFE	Dichtung PTFE	Junta PTFE	3
12	930.151.598	Vis CHc M 6x60	Screw, model CHc M 6x60	Schraube M 6x60	Tornillo, tipo CHc M 6x60	4
13	931.151.168	Vis CHc M 5x12	Screw, model CHc M 5x12	Schraube M 5x12	Tornillo, tipo CHc M 5x12	4
14	953.020.021	Ecrou HM 10	Nut, model HM 10	Mutter M 10	Tuerca, tipo HM 10	4
15	963.040.021	Rondelle M 10	Washer, model M 10	Scheibe M 10	Arandela, tipo M 10	4
20	905.210.403	Coude inox MF 1/2	Elbow, model MF 1/2 (stainless steel)	Bogen MF 1/2 Edelstahl	Codo, tipo MH 1/2 de inox	1
23	050.040.317	Joint PTFE	Seal, PTFE	Dichtung PTFE	Junta PTFE	1
* 24	044.960.201	Piston	Piston	Kolben	Pistón	1
25	044.960.202	Bride de refoulement	Discharge flange	Absaugflansch	Brida de expulsión	1
26	044.960.203	Bride joint GT	Flange, GT seal	GT-Dichtungsflansch	Brida junta GT	1
* 27	044.960.002	Cylindre	Cylinder	Materialzylinder	Cilindro	1
28	909.150.213	Joint GT supérieur	GT seal, upper	Oberer GT-Dichtung	Junta GT superior	1
30	933.151.526	Vis CHc M 8x45	Screw, model CHc M 8x45	Schraube M 8x45	Tornillo, tipo CHc M 8x45	4
<b>* A</b>	<b>144.960.500</b>	<b>Ensemble clapet de refoulement</b>	<b>Exhaust valve kit</b>	<b>Absaugventil komplett</b>	<b>Kit válvula de expulsión</b>	<b>1</b>
31	909.150.215	▪ Joint GT inférieur	▪ GT seal, lower	▪ Unterer GT- Dichtung	▪ Junta GT inferior	1
32	907.414.223	▪ Bille Ø 9,52, inox 440 C	▪ Ball, model Ø 9,52, (440 C stainless steel)	▪ Kugel Ø 9,52 Edelstahl	▪ Bola, tipo Ø 9,52 de inox 440 C	1
33	044.960.204	▪ Rondelle GT	▪ Washer, GT	▪ Scheibe GT	▪ Arandela GT	1
34	044.960.215	▪ Clapet de refoulement	▪ Exhaust valve	▪ Absaugventil	▪ Válvula de expulsión	1
<b>* 35</b>	<b>044.950.225</b>	<b>Clapet d'aspiration assemblé</b>	<b>Suction valve assembly</b>	<b>Ansaugventil komplett</b>	<b>Válvula de aspiración montada</b>	<b>1</b>
a	NCS / NSS	▪ Corps de clapet	▪ Suction valve body	▪ Ansaugventilkörper	▪ Cuerpo de válvula	1
21	044.550.029	▪ Jonc	▪ Rush	▪ Sicherungsring	▪ Anillo de retención bola	1
22	907.414.242	▪ Bille Ø 16, inox 440C	▪ Ball, model Ø 16, 440C (stainless steel)	▪ Kugel Ø 16, Edelstahl	▪ Bola, tipo Ø 16 de inox 440C	1
29	050.040.318	▪ Joint torique PTFE	▪ O Ring PTFE	▪ O-Ring PTFE	▪ Junta torica PTFE	1

Ind	#	Désignation	Description	Bezeichnung	Denominación	Qté
36	144.970.106	Joint (les 10)	Seal (pack of 10)	O-Ring (10 St.)	Junta (bolsa de 10)	1
37	044.970.107	Bague de serrage	Tightening ring	Klemmring	Anillo de apriete	1
38	049.595.306	Ecrou raccord M 38x150	Nut fitting, model M 38x150	Überwurfmutter M 38x1,5	Tuerca racor, tipo M 38x150	1
39	044.950.271	Tube de liaison avec vis (ind. 41&43)	Fluid tube, attachment with screws (ind. 41&43)	Verbindungsrohr mit Schrauben (ind. 41&43)	Tubo de unión con tornillos (ind. 41&43)	1
40	129.489.902	Joint PTFE (les 10)	Seal, PTFE (pack of 10)	Dichtung PTFE (10 St.)	Junta PTFE (bolsa de 10)	1
41	933.151.196	Vis CHc M 6x16	Screw, model CHc M 6x16	Schraube M 6x16	Tornillo, tipo CHc M 6x16	2
42	150.040.321	Joint PTFE (les 10)	Seal, PTFE (pack of 10)	Dichtung PTFE (10 St.)	Junta PTFE (bolsa de 10)	1
43	933.151.196	Vis CHc M 6x16	Screw, model CHc M 6x16	Schraube M 6x16	Tornillo, tipo CHc M 6x16	2

Ind	#	Désignation	Description	Bezeichnung	Denominación	Qté
*	144.960.291	Pochette de joints (ind. 11, 21, 22, 23, 28, 29, 31, 32, 36, 40, 42)	Package of seals (ind. 11, 21, 22, 23, 28, 29, 31, 32, 36, 40, 42)	Dichtungssatz (beinhaltet Pos. 11, 21, 22, 23, 28, 29, 31, 32, 36, 40, 42)	Bolsa de juntas (ind. 11, 21, 22, 23, 28, 29, 31, 32, 36, 40, 42)	1
*	144.960.292	Pochette de maintenance (ind. 33, 34, 35 + pochette de joints)	Servicing kit (ind. 33, 34, 35 + package of seals)	Servicekit (beinhaltet Pos. 33, 34, 35 und den Dichtungssatz)	Bolsa de reparación (ind. 33, 34, 35 + bolsa de juntas)	1

\* Pièces de maintenance préconisées tenues en stock.

\* Preceding the index number denotes a suggested spare part.

\* Bezeichnete Teile sind empfohlene Ersatzteile.

\* Piezas de mantenimiento preventivas a tener en stock.

N C S : Non commercialisé seul.

N S S : Denotes parts are not serviceable separately.

N S S : bezeichnete Teile gibt nicht einzeln, sondern nur komplett .

N S S : no suministrado por separado.

Ind	#	EN OPTION :	OPTIONAL :	OPTION :	OPCIÓN :	Qté
Ind	#	Désignation	Description	Bezeichnung	Denominación	Qté
22	907.414.142	Bille Ø 16 inox 316	Ball, model Ø 16 (316 stainless steel)	Kugel (Edelstahl), Ø 16, 316	Bola, tipo Ø 16 de inox 316	1
32	907.414.123	Bille Ø 9,52 inox 316	Ball, model Ø 9,52 (316 stainless steel)	Kugel (Edelstahl), Ø 9,52, 316	Bola, tipo Ø 9,52 de inox 316	1

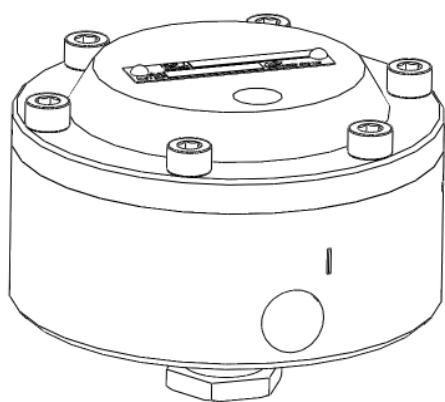

## INSTRUCTION MANUAL

# LP AIR OPERATED PRESSURE REGULATOR for fluid materials

***Small passage***

*Manual : 1201 573.203.112*

*Date : 23/01/12 - Supersede : 01/07/08*

*Modif. Update*

### TRANSLATION OF THE ORIGINAL MANUAL

**IMPORTANT : Before assembly and start-up, please read and clearly understand all the documents relating to this equipment (professional use only).**

*THE PICTURES AND DRAWINGS ARE NON CONTRACTUAL. WE RESERVE THE RIGHT TO MAKE CHANGES WITHOUT PRIOR NOTICE.*

#### ADDITIONAL DOCUMENTATIONS

**SPARE PARTS :**

Air piloted regulator (small passage)

**# Doc**

Doc. 573.415.050

**KREMLIN - REXSON**

150, avenue de Stalingrad

93 245 - STAINS CEDEX – France

☎ : 33 (0)1 49 40 25 25

Fax : 33 (0)1 48 26 07 16

**[www.kremlin-rexson.com](http://www.kremlin-rexson.com)**



**INSTRUCTION MANUAL**  
**LP PRESSURE REGULATOR**

**TABLE OF CONTENTS**

1. WARRANTY .....	2
2. SAFETY INSTRUCTIONS .....	3
3. DESCRIPTION .....	6
4. TECHNICAL FEATURES.....	6
5. INSTALLATION .....	7
6. STARTING UP .....	7
7. MAINTENANCE .....	7
8. TROUBLESHOOTING CHART .....	8
9. DISASSEMBLY / ASSEMBLY.....	8

Dear Customer,

You are the owner of our new KREMLIN pressure regulator and we would like to take this opportunity to thank you.

To make sure your investment will provide full satisfaction, special care has been taken by KREMLIN REXSON during all designing and manufacturing processes.

To obtain the best result, safe and efficient operation of your equipment, we advice you to read and make yourself familiar with this instruction and service manual.

## 1. WARRANTY

We reserve the right to make changes; these changes may be carried out after the receipt of our order. No claim will be accepted as a consequence of any change carried out in the instruction manuals or in the selection guides.

Our equipment is checked and tested prior to shipment. In the case of a problem arising with the equipment, this must be in writing, within ten days from the delivery date.

KREMLIN REXSON warrants all equipment manufactured bearing its name, to be free from defect in material or workmanship for a period of 12 months (one shift per day or 1800 hours - 1 term reached) from the date of delivery. Work life is based on single shift working - 8 hours per day. Warranty claims for defective items will only be accepted in writing and will be verified and confirmed by us.

The warranty does not cover fair wear tear, damage or wear caused by misuse, improper maintenance or non-observance of our recommendations.

KREMLIN REXSON will repair or replace parts (carriage paid to our plant and accepted as defective by us). We shall not be liable for any losses, resulting from a production breakdown. Upon request, we can carry out service work at your premises; all expenses (travelling and accommodation) for KREMLIN REXSON technicians will be chargeable.

In the event that it is found that equipment has been tampered with, this will invalidate the warranty. Equipment that is bought in will be subject to the supplier's warranty.

## 2. SAFETY INSTRUCTIONS

### GENERAL SAFETY INSTRUCTIONS



**CAUTION :** The equipment can be dangerous if you do not follow our instructions concerning installation and servicing described in this manual and in accordance with applicable European standards and local national safety regulations.

Please carefully read all the instruction literature before operating your equipment.

**Only trained operators can use the equipment** (To acquire an essential training, please contact the "KREMLIN REXSON University" training center - Stains).

The foreman must ensure that the operator has understood the safety instructions for this equipment as well as the instructions in the manuals for the different parts and accessories.

Read carefully all instruction manuals, label markings before operating the equipment.

Incorrect use may result in injury. This equipment is for professional use only. It must be used only for what it has been designed for. Never modify the equipment. The parts and accessories supplied must be regularly inspected. Defective or worn parts must be replaced.



















**Guards (air motor cover, coupling shields, housings,...) have been designed for a safe use of the equipment.**

**The manufacturer will not be held responsible for bodily injury or failure and / or damage to property due to removal or partial removal of the guards.**

**Never exceed the equipment components' maximum working pressure.**

Comply with regulations concerning safety, fire risks, electrical regulations in force in the country of final destination of the material. Use only products or solvent compatible with the parts in contact with the material (refer to data sheet of the material manufacturer).

### PICTOGRAMS

					
NIP HAZARD	WARNING MOVING ELEVATOR	WARNING MOVING PARTS	WARNING MOVING SHOVEL	DO NOT EXCEED THIS PRESSURE	HIGH PRESSURE HAZARD
					
RELIEF OR DRAIN VALVE	WARNING HOSE UNDER PRESSURE	WEAR GLASSES OBLIGATORY	WEAR OF GLOVES IS OBLIGATORY	PRODUCT VAPOR HAZARDS	WARNING HOT PARTS OR AREAS
					
ELECTRICAL HAZARD	WARNING FIRE HAZARDS	EXPLOSION HAZARDS	GROUNDING	WARNING (USER)	WARNING SERIOUS INJURIES

## FIRE - EXPLOSION - SPARKS - STATIC ELECTRICITY HAZARDS



A poor earth connection, inadequate ventilation, sparks or static electricity can cause an explosion or fire. To avoid these risks when using or servicing KREMLIN REXSON equipment, the following safety procedures must be followed :

- ensure a good earth connection and ground the parts to be handled i.e. solvents, materials, components and equipment,
- ensure adequate ventilation,
- keep working area clean and free from waste solvents, chemicals, or solid waste i.e. rags, paper and empty chemicals drums,
- never use electrical switches / power if in an atmosphere of volatile solvent vapour,
- stop working immediately in case of electrical arcs,
- never store chemicals and solvents in the working area.
- use paint whose flash point is the highest possible to prevent from any formation of gas and inflammable vapours (refer to materials' safety instructions),
- install a cover on the drums to reduce the diffusion of gas and vapours in the spraybooth.

## TOXIC PRODUCT HAZARDS



Toxic products or vapours can cause severe injury not only through contact with the body, but also if the products are ingested or inhaled. It is imperative :

- to know the material products and their risks,
- notified or hazardous materials must be stored in accordance with the regulations,
- the material must be stored in an appropriate container, never place materials in a container where there is a risk of spillage or leakage,
- a procedure must be applied for the safe disposal of waste material. It must comply with all prevailing regulations and legislations of the country where the equipment is to be used,
- protective clothing should always be worn in compliance with the material manufacturers' recommendations,
- depending on the application and chemical safety instructions, safety glasses, hearing protective earplug, gloves, foot wear, protective masks and possible breathing equipment should be worn to comply with the regulations (Refer to chapter "Safety equipment of KREMLIN selection guide).



### **CAUTION!**

It is forbidden to use material containing high concentrations of halogenated hydrocarbon solvents with **aluminium** or **zinc fillers**. Non-compliance with the instructions may cause explosion risk causing serious or fatal injury.

## EQUIPMENT REQUIREMENTS

**Guards (air motor cover, coupling shields, housings,...) have been designed for a safe use of the equipment.**  
**The manufacturer will not be held responsible for bodily injury or failure and / or damage to property due to removal or partial removal of the guards.**

### **PUMP**



Before carrying out any work, it is imperative to read and clearly understand the disassembly and reassembly instructions before servicing. The operator must understand the equipment and the safety instructions. These instructions are available in the equipment manuals.



The air motor is designed to be mounted with a pump. Never modify any components or couplings. When operating, please keep hands away from moving parts. Before starting up the equipment, please read the PRESSURE RELIEF instructions. Please ensure that any relief or drain valves fitted are in good working order.

### **HOSES**

- Keep hoses out of circulation areas, moving parts or hot surfaces,
- Never expose product hoses to temperature higher than + 60°C / 140° F or lower than 0°C / 32° F,
- Never pull or use the hoses to move the equipment,
- Tighten all fittings as well as the hoses before operating the equipment,
- Check the hoses regularly; change them if they are damaged,
- Never exceed the maximum working pressure (MWP) indicated on the hose.

## USED PRODUCTS

Considering the wide variety of products that are available and can be used in our equipment it is impossible to check and make recommendations for all chemical data, regarding the risks of possible chemical attack and their long term chemical reaction

KREMLIN REXSON can not be held liable for :

- Compatibility of wetted parts,
- Risks to staff and the surroundings,
- for worn or defective parts, for faulty equipment or units, or the quality of final product.

It is the responsibility of the user to know and prevent any possible risks such as toxic vapours, fires or explosions. He shall determine the risks of immediate reactions or pursuant to repeated exposures of the staff,

KREMLIN REXSON shall not be liable for physical injuries, direct or indirect material damages caused by the use of chemicals.

### PRESSURE REGULATOR

- ➡ Install conductive hoses upstream and downstream of the regulator.
- ➡ Respect the inlet and outlet pressures of the regulator.



### 3. DESCRIPTION

The pressure regulator enables to adjust the fluid pressure into the low pressure circuits. It is in stainless steel and is designed for a flushing.

**The pressure regulator** is mounted on the fluid circuit between the pump fluid outlet and the gun fluid inlet. It enables to refine the pressure of the gun.

The adjustment of the fluid pressure at the regulator outlet is carried out by adjusting the air pilot pressure. That air pilot must be driven via a precision air regulator to obtain a better adjustment of the piloted regulator.

1 bar of air corresponds to 1 bar at exit produces with the output close to the system.

The letter (I) marked on the body indicates the inlet of the fluid flow.

### 4. TECHNICAL FEATURES

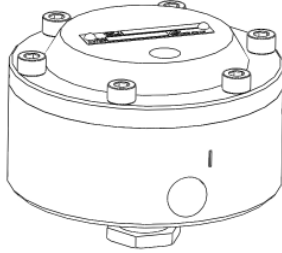
Type	Air operated regulator (small passage)
	
<b>Version</b>	40 - 0/6
<b>Pressure range :</b>	
- Maximum inlet pressure	40 bar / 580 psi
- Outlet pressure	From 0 to 6 bar / from 0 to 87 psi
- Maximum piloted air pressure	6 bar / 87 psi
<b>Fittings :</b>	
- Fluid inlet (I)	F 3/8 NPS
- Fluid outlet	F 3/8 NPS
- Air pilot inlet	Rp 1/4
<b>Wetted parts</b>	Stainless steel, PTFE, carbide
<b>Weight</b>	2.6 kg / 5.7 lbs
<b>Maximum temperature</b>	50°C / 122° F

## 5. INSTALLATION

### ■ DESCRIPTION OF THE LABEL MARKING

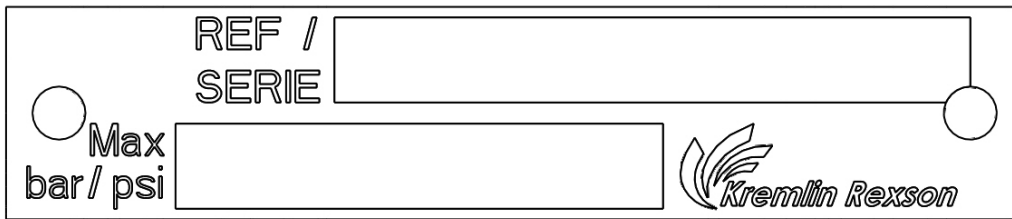

<b>Sigle KREMLIN</b>	Manufacturer acronym
<b>REF / SERIE</b>	Regulator part number / Number given by KREMLIN REXSON. The two first numbers indicate the manufacturing year.
<b>Max bar/psi</b>	Regulator maximum fluid pressure

### ■ HOSES RECOMMENDED

You must choose the hoses according to the material viscosity and to the length. Make sure the hose has a larger diameter for higher length or important viscosity.

## 6. STARTING UP

Start up the pump (Refer to pump instruction manual).

Tighten the screw located on the upper part of the spring operated regulator or turn the regulator of the air operated assembly.

Start up the gun (Refer to gun instruction manual).

Adjust the fluid regulator to obtain the required pressure and flowrate for the gun.

**Nota : Respect the inlet and outlet pressures.**

## 7. MAINTENANCE

Keep the pressure regulator clean to ensure its proper working.

When flushing the pump, make the solvent circulate in the complete circuit to clean all the elements (pump, hoses, regulator, gun).

## 8. TROUBLESHOOTING CHART

FAULT	CAUSE	SOLUTION
Overpressure at the outlet of the regulator	Pilot air pressure too high Improper proofness between seat and ball.	Decrease the pilot pressure. Clean or change.
No material coming out from the regulator	Insufficient pilot air pressure Ball blocked on the seat, needle-axis assembly broken	Increase the pilot air pressure. Clean and reinstall or change..
Irregular flowrate	Pulsation too important on the distribution network Seat, ball and spring not tight	Adjust the inlet pressure. Clean or change.
Leakage at the upper part of the regulator	Defective fluid diagrams Screws improperly tightened on the lower body	Change them. Tighten the screws.

## 9. DISASSEMBLY / ASSEMBLY



**WARNING :** Before any action on the installation, shut off the compressed air supply and depressurize the systems by triggering the spray gun.

**Guards (air motor cover, coupling shields, housings,...) have been designed for a safe use of the equipment.**

**The manufacturer will not be held responsible for bodily injury or failure and / or damage to property due to removal or partial removal of the guards.**

### ■ CLEANING OF THE REGULATION VALVE (5)

Unscrew the plug (11). Take off the spring (10) and the ball (9).  
Clean the parts with the appropriate cleaning solvent.  
Change them if necessary. During the assembly, change the seals (6).  
Reinstall the parts with the regulator in the vertical position. Tighten the plug (11).

### ■ CHANGING OF THE SEAT (7)

#### Disassembly :

Unscrew the 6 screws (2) and remove the lower body (4).  
Unscrew the plug (11). Remove the spring (10) and the ball (9).  
Push on the seat (7) to remove the lower body (4).  
Clean the parts or replace with new ones.

#### Assembly :

Change the 2 seals (6), the seat (7) and the ball (9). (refer to regulation assembly - ind. 5).  
Reinstall the seat (7), the ball guide (8), the ball (9), the spring (10) and the plug (11) in the lower body (4).  
Install the lower body and the upper part by means of the 6 screws (2).

■ **CHANGING OF THE DIAPHRAGMS ASSEMBLY (3)**

**Disassembly :**

Unscrew the 6 screws (2) and remove the lower body (4).  
 Unstick carefully the diaphragms assembly (3) from the lower body (4).  
 Replace with a new diaphragms assembly.

**Assembly :**

Insert the diaphragms assembly (3) in the lower body (4).  
 Reinstall the lower body (4) fitted with the regulation valve (5) by means of the 6 screws (2).

➤ **IMPORTANT :** when reassembling, the needle of the diaphragms assembly (3) must be inside the central port of the seat (7), until getting in touch with the ball (9).

Before reassembling the different components :

- Clean the parts with the appropriate cleaning solvent,
- Install new seals after having lubricated them with PTFE grease.
- Install new parts if necessary.

■ **ASSEMBLY INSTRUCTIONS**

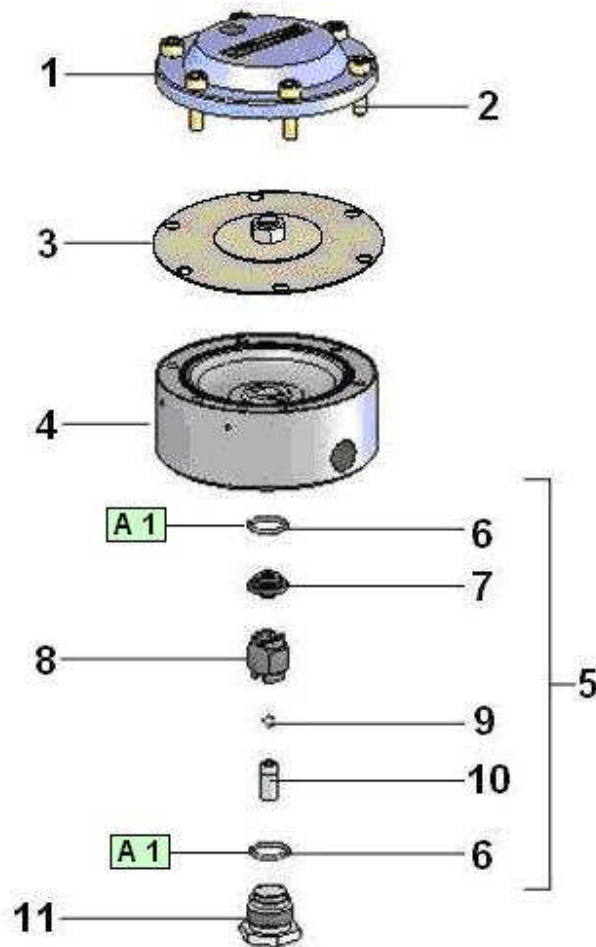

Index	Instruction	Description	Part number
A1	PTFE grease	'TECHNILUB' grease (10 ml)	560.440.101

<b>Doc. 573.415.050</b> Date/Datum/Fecha : 16/03/15 Annule/Cancel/ Ersetzt/Anula : 26/10/11	<b>Modif. /Änderung :</b> + option bille céramique / Ceramic ball on request / optional Keramik Kugel / opción bola cerámica	<b>Pièces de rechange</b> <b>Spare parts list</b> <b>Ersatzteilliste</b> <b>Piezas de repuesto</b>
--	---	---

<b>REGULATEUR PRODUIT BP</b> <b>(petit passage)</b>	<b>LP FLUID PRESSURE REGULATOR</b> <b>(small passage)</b>
<b>BP MATERIALDRUCKREGLER</b> <b>(kleiner Durchgang)</b>	<b>REGULADOR DE PRESION BP</b> <b>(paso pequeño)</b>

**REGULATEUR DE PRESSION PILOTÉ**  
**LP AIR OPERATED PRESSURE REGULATOR**  
**NIEDERDRUCK-MATERIALDRUCKREGLERDRUCKREGLER MIT LUFTSTEUERUNG**  
**REGULADOR DE PRESIÓN PILOTADO BP**

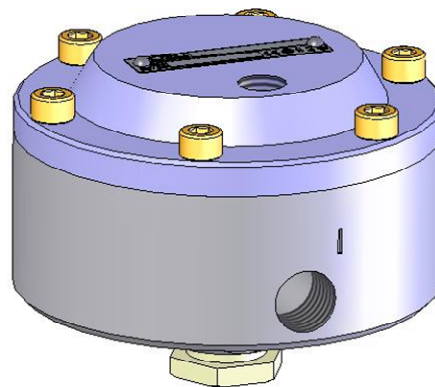

**Mod. : 40 - 0 / 6 bar**

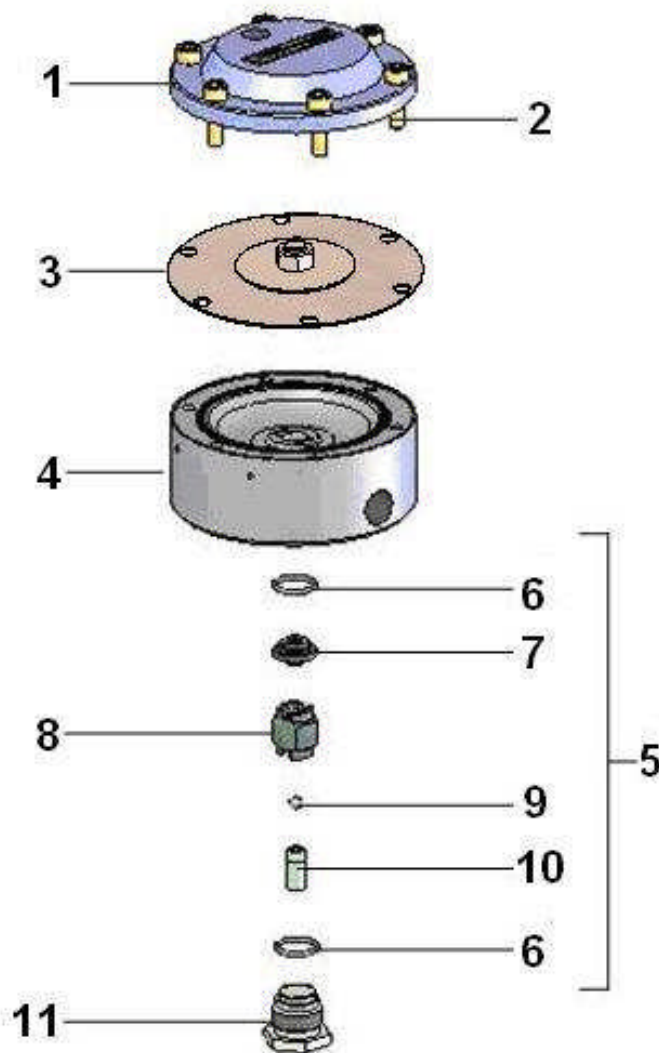

**# 155.610.520**

Entrée produit / Fluid inlet / Materialeingang / Entrada de producto : "I" 3/8 NPS  
 Sortie produit / Fluid outlet / Materialausgang / Salida de producto : 3/8 NPS



Ind	#	Désignation	Description	Bezeichnung	Denominación	Qté
1	NC / NS	Carter supérieur	Upper housing	Oberes Gehäuse	Cárter superior	1
2	NC / NS	Vis CHc M 6 x 20	Screw, model CHc M 6 x 20	Schraube, M 6 x 20	Tornillo, tipo CHc M 6 x 20	6
*3	155 610 560	Ensemble membranes	Diaphragm kit	Membranensatz	Conjunto membrana	1
4	NC / NS	Corps inférieur	Lower body	Körper, Unterteil	Cuerpo inferior	1
<b>*5</b>	<b>155 271 903</b>	<b>Ensemble de régulation</b>	<b>Regulation assembly</b>	<b>Reglereinheit</b>	<b>Conjunto de regulación</b>	<b>1</b>
6	150 040 314	▪ Joint torique, PTFE (pochette de 10)	▪ O-Ring, PTFE (pack of 10)	▪ PTFE-Dichtung (10 St.)	▪ Junta tórica , PTFE (bolsa de 10)	2
7	NC / NS	▪ Siège	▪ Seat	▪ Sitz	▪ Asiento	1
9	NC / NS	▪ Bille Ø 5, carbure	▪ Ball Ø 5, carbide	▪ Kugel Ø 5, Hartmetall	▪ Bola Ø 5, carburo	1
10	NC / NS	▪ Ressort conique	▪ Conical spring	▪ Konische Feder	▪ Muelle cónico	1
8	055 610 538	Guide bille	Ball guide	Kugelführung	Guía bola	1
11	NC / NS	Bouchon	Plug	Stopfen	Tapón	1

**OPTION - ON REQUEST - OPTIONAL - OPCIÓN**

	#	Désignation	Description	Bezeichnung	Denominación
	155 610 576	Support pour régulateur	Support, regulator	Wandhalterung für Regler	Soporte para regulador
	155 610 570	Kit manomètre (0-16 bar) (3/8 NPT - 3/8 NPS)	Gauge kit (0-16 bar / 0-232 psi) (3/8 NPT - 3/8 NPS)	Manometersatz (0-16 bar) (3/8 NPT - 3/8 NPS)	Kit manómetro (0-16 bar) (3/8 NPT - 3/8 NPS)

**Produits hydrodiluable et abrasifs / Water-based and abrasive product  
/ Für wasserbasis und abrasive Produkte / Productos hidrosolubles y abrasivos**

Ind	#	Désignation	Description	Bezeichnung	Denominación	Qté
*	155 271 793	Pochette de maintenance cartouche - bille céramique (ind. 7, 9, 10) + pochette de joints cartouche	Servicing kit cartridge - ball ceramic (ind. 7, 9, 10) + cartridge package of seals	Servicekit Packung - Keramik Kugel (Pos. 7, 9, 10) + Packung Dichtringsatz	Bolsa de reparación cartucho - bola cerámica (ind. 7, 9, 10) + bolsa de juntas cartucho	1
7	055 271 717	▪ Siège	▪ Seat	▪ Sitz	▪ Asiento	1
9	907 414 701	▪ Bille Ø 5, céramique	▪ Ball Ø 5, ceramic	▪ Kugel Ø 5, Keramik	▪ Bola Ø 5, ceramica	1
10	050 313 211	▪ Ressort conique	▪ Conical, spring	▪ Konische Feder	▪ Muelle cónico	1
-	155 271 792	▪ Pochette de joints cartouche	▪ Cartridge package of seals	▪ Packung Dichtringsatz	▪ Bolsa de juntas cartucho	1

\* Pièces de maintenance préconisées.

\* Preceding the index number denotes a suggested spare part.

\* Bezeichnete Teile sind empfohlene Ersatzteile.

\* Piezas de mantenimiento preventivas.

N C : Non commercialisé.

N S : Denotes parts are not serviceable.

N S : Bezeichnete Teile gibt es nicht einzeln, sondern nur komplett.

N S : no suministrado.

<b>Doc. 573.187.050</b> Date/Datum/Fecha : 31/05/16 Annule/Cancel/ Ersetzt/Anula : 21/04/15	<b>Modif. / Änderung :</b> Airmix® 200 bar / 2900 psi → Ind. / Pos. 6 (155.535.315 → 155.528.011)	<b>Pièces de rechange</b> <b>Spare parts list</b> <b>Ersatzteilliste</b> <b>Piezas de repuesto</b>
--	--	---

<b>CTM</b>	<b>CHANGEUR DE TEINTES INOX / STAINLESS STEEL COLOR CHANGER</b> <b>/ FARBWECHSELBLOCK - EDELSTAHL / CAMBIO DE COLOR INOX</b>
------------	---

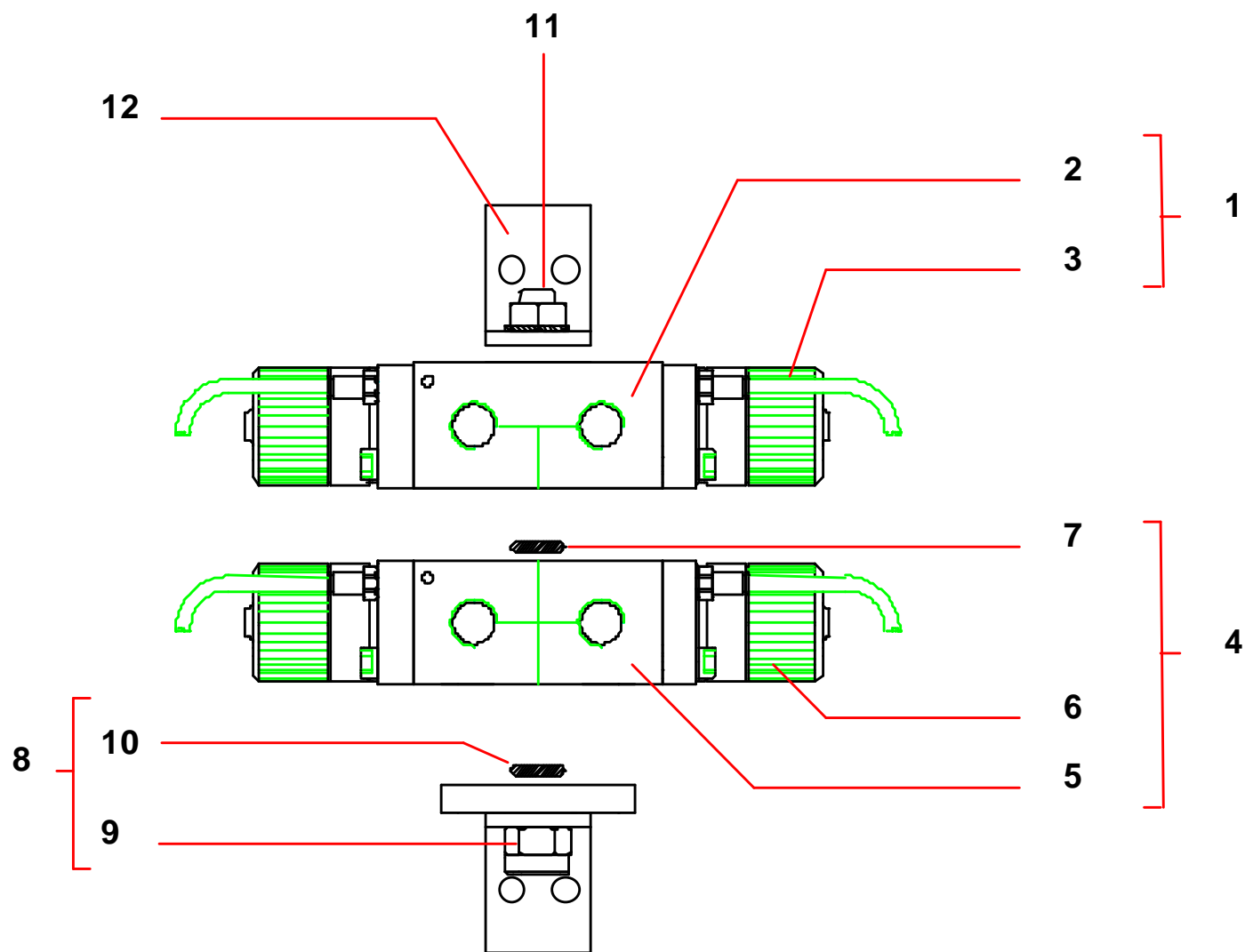



**Version pneumatique / Airspray version / Niederdruck Version / Versión neumática**

Ind	#	Désignation	Description	Bezeichnung	Denominación	Qté
*1	155 535 100	<b>Module pneumatique d'extrémité</b>	<b>End module (material or solvent or air inlet)</b>	<b>Unteres Modul (Endmodul)</b>	<b>Modulo neumático de extremidad</b>	1
2	055 535 101	• Corps du module	• Body	• Modulkörper	• Cuerpo del modulo	1
*3	155 535 110	• Vanne pneumatique	• Airspray valve	• Niederdruckventil	• Válvula neumática	2
*4	155 535 200	<b>Module pneumatique de commutation</b>	<b>Intermediate module (material inlet only)</b>	<b>Zwischen Modul (Materialeingang)</b>	<b>Modulo neumático intermediario</b>	<b>1X N</b>
5	055 535 201	• Corps du module	• Body	• Modulkörper	• Cuerpo del modulo	1
*6	155 535 110	• Vanne pneumatique	• Airspray valve	• Niederdruckventil	• Válvula neumática	2
*7	155 535 710	• Joint PTFE (x 10)	• Seal, PTFE (x 10)	• PTFE-Dichtung (10 St.)	• Junta PTFE (x 10)	1

**Version Airmix® (120 bar) / Airmix Version (120 bar / 1740 psi)**

*1	155 535 300	<b>Module AIRMIX® d'extrémité (120 bar)</b>	<b>End module (material or solvent or air inlet)</b>	<b>Unteres Modul (Endmodul) (120 bar)</b>	<b>Modulo AIRMIX® de extremidad (120 bar)</b>	1
2	055 535 301	• Corps du module	• Body	• Modulkörper	• Cuerpo del modulo	1
*3	155 535 310	• Vanne AIRMIX® (120 bar)	• AIRMIX valve (120 bar / 1740 psi)	• Airmix® -Ventil (120 bar)	• Válvula AIRMIX® (120 bar)	2
*4	155 535 400	<b>Module AIRMIX® de commutation (120 bar)</b>	<b>Intermediate module (material inlet only) (120 bar / 1740 psi)</b>	<b>Zwischen-Modul (Materialeingang) (120 bar)</b>	<b>Modulo AIRMIX® intermediario (120 bar)</b>	<b>1X N</b>
5	055 535 401	• Corps du module	• Body	• Modulkörper	• Cuerpo del modulo	1
*6	155 535 310	• Vanne AIRMIX® (120 bar)	• AIRMIX valve (120 bar / 1740 psi)	• AIRMIX® -Ventil (120 bar)	• Válvula AIRMIX® (120 bar)	2
*7	155 535 710	• Joint PTFE (les 10)	• Seal, PTFE (x 10)	• PTFE-Dichtung (10 St.)	• Junta PTFE (x 10)	1

**Version Airmix® (200 bar) / Airmix® Version (200 bar / 2900 psi)**

Ind	#	Désignation	Description	Bezeichnung	Denominación	Qté
*1	155 535 350	<b>Module d'extrémité AIRMIX® GT (200 bar) (pour machine dont le numéro de série est &gt; à 15T1003)</b>	<b>GT AIRMIX end module (material or solvent or air inlet) (200 bar / 2900 psi) (for machine which part number is &gt; to 15T1003)</b>	<b>Unteres Modul GT (Endmodul) (200 bar) (für Maschinen mit Seriennummer ab &gt; 15T1003)</b>	<b>Modulo de extremidad AIRMIX® GT (200 bar) (para máquina cuyo número de serie es superior a 15T1003)</b>	1
2	055 535 301	• Corps du module	• Body	• Modulkörper	• Cuerpo del modulo	1
*3	155 528 011	• Vanne AIRMIX® GT (200 bar)	• GT AIRMIX valve (200 bar / 2900 psi)	• AIRMIX® -Ventil GT (200 bar)	• Válvula AIRMIX® GT (200 bar)	2
*4	155 535 450	<b>Module AIRMIX® de commutation (200 bar)</b>	<b>Intermediate module (material inlet only) (200 bar / 2900 psi)</b>	<b>Zwischen-Modul (Materialeingang) (200 bar)</b>	<b>Modulo AIRMIX® intermediario (200 bar)</b>	<b>1X N</b>
5	055 535 401	• Corps du module	• Body	• Modulkörper	• Cuerpo del modulo	1
*6	155 528 011	• Vanne AIRMIX® GT (200 bar)	• GT AIRMIX valve (200 bar / 2900 psi)	• AIRMIX® -Ventil GT (200 bar)	• Válvula AIRMIX® GT (200 bar)	2
*7	155 535 710	• Joint PTFE (les 10)	• Seal, PTFE (x 10)	• PTFE-Dichtung (10 St.)	• Junta PTFE (x 10)	1

**Pièces communes - Common parts - Gleiche Teile - Partes comunes**

Ind	#	Désignation	Description	Bezeichnung	Denominación	Qté
*8	155 535 500	Bride de sortie équipée	Flange assembly, material outlet	Ausgangsflansch (Materialausgang) kpl.	Brida de salida equipada	1
9	NC / NS	• Bride de sortie nue	• Bare outlet flange	• Ausgangsflansch,nackt	• Brida de salida sola	1
*10	155 535 710	• Joint PTFE (les 10)	• Seal, PTFE (x 10)	• PTFE- Dichtung (10 St.)	• Junta PTFE (x 10)	1

<b>CHANGEUR DE TEINTES INOX 316 L</b>	<b>COLOR CHANGER, 316 L STAINLESS STEEL</b>
<b>FARBWECHSELBLOCK - EDELSTAHL 316 L</b>	<b>CAMBIO DE COLOR INOX 316 L</b>

**Version Airmix ® (200 bar) / Airmix Version (200 bar / 2900 psi)**

Ind	#	Désignation	Description	Bezeichnung	Denominación	Qté
*1	155 536 200	Module AIRMIX® d'extrémité (200 bar) (inox 316 L)	End module (material or solvent or air inlet) (200 bar / 2900 psi) (stainless steel, 316 L)	Unteres Modul (Endmodul) (200 bar) (Edelstahl 316 L)	Modulo AIRMIX® de extremidad (200 bar) (inox 316 L)	1
2	055 536 301	• Corps du module (inox 316 L)	• Body (stainless steel, 316 L)	• Modulkörper (Edelstahl 316 L)	• Cuerpo del modulo (inox 316 L)	1
*3	155 536 300	• Vanne AIRMIX® (200 bar) (inox 316 L)	• AIRMIX valve (200 bar / 2900 psi) (stainless steel, 316 L)	• AIRMIX® -Ventil (200 bar) (Edelstahl 316 L)	• Válvula AIRMIX® (200 bar) (inox 316 L)	2
*4	155 536 320	Module AIRMIX® de commutation (200 bar) (inox 316 L)	Intermediate module (material inlet only) (200 bar / 2900 psi) (stainless steel, 316 L)	Zwischen-Modul (Materialeingang) (200 bar) (Edelstahl 316 L)	Modulo AIRMIX® intermédiaire (200 bar) (inox 316 L)	1X N
5	055 536 401	• Corps du module (inox 316 L)	• Body (stainless steel, 316 L)	• Modulkörper (Edelstahl 316 L)	• Cuerpo del modulo (inox 316 L)	1
*6	155 536 300	• Vanne AIRMIX® (200 bar) (inox 316 L)	• AIRMIX valve (200 bar / 2900 psi) (stainless steel, 316 L)	• Airmix® -Ventil (200 bar) (Edelstahl 316 L)	• Válvula AIRMIX® (200 bar) (inox 316 L)	2
*7	155 535 710	• Joint PTFE (les 10)	• Seal, PTFE (x 10)	• PTFE-Dichtung (10 St.)	• Junta PTFE (x 10)	1
*8	155 536 410	Bride de sortie équipée	Flange assembly, material outlet	Ausgangsflansch (Materialausgang) kpl.	Brida de salida equipada	1
9	NC / NS	• Bride de sortie nue (inox 316 L)	• Bare flange (stainless steel, 316 L)	• Ausgangsflansch,nackt (Edelstahl 316 L)	• Brida de salida sola (inox 316 L)	1
*10	155 535 710	• Joint PTFE (les 10)	• Seal, PTFE (x 10)	• PTFE-Dichtung (10 St.)	• Junta PTFE (x 10)	1

\* Pièces de maintenance préconisées

\* Preceding the index number denotes a suggested spare part.

\* Bezeichnete Teile sind empfohlene Ersatzteile.

\* Piezas de mantenimiento preventivas.

N C : Non commercialisé.

N S : Denotes parts are not serviceable.

N S : bezeichnete Teile gibt nicht einzeln, sondern nur komplett.

N S : no suministrado.

## TIRANT / TIE-RODS / VERBINDUNGSBOLZEN / TIRANTE

Ind	#	Désignation	Description	Bezeichnung	Denominación	Qté
*11	---	<b>Ensemble de 2 tirants pour :</b>	<b>Set of 2 tie-rods for :</b>	<b>Verbindungsbolzen (Satz mit 2 Stück) für:</b>	<b>Conjunto de 2 tirantes para :</b>	1
-	155 535 610	• 1 module (1 d'extrémité + 1 bride)	• 1 module (1 end module + 1 flange)	• 1 Modul (1 Endmodul + 1 Ausgangsflansch)	• 1 modulo (1 de extremidad + 1 brida)	-
-	155 535 620	• 2 modules (1 d'extrémité + 1 de commutation + 1 bride)	• 2 modules (1 end module + 1 intermediate module + 1 flange)	• 2 Module (1 Endmodul + 1 Zwischenmodul + 1 Ausgangsflansch)	• 2 modulos (1 de extremidad + 1 intermediario + 1 brida)	-
-	155 535 630	• 3 modules (1 d'extrémité + 2 de commutation + 1 bride)	• 3 modules (1 end module + 2 intermediate modules + 1 flange)	• 3 Module (1 Endmodul + 2 Zwischenmodule + 1 Ausgangsflansch)	• 3 modulos (1 de extremidad + 2 intermediario + 1 brida)	-
-	155 535 640	• 4 modules (1 d'extrémité + 3 de commutation + 1 bride)	• 4 modules (1 end module + 3 intermediate modules + 1 flange)	• 4 Module (1 Endmodul + 3 Zwischenmodule + 1 Ausgangsflansch)	• 4 modulos (1 de extremidad + 3 intermediario + 1 brida)	-
-	155 535 650	• 5 modules (1 d'extrémité + 4 de commutation + 1 bride)	• 5 modules (1 end module + 4 intermediate modules + 1 flange)	• 5 Module (1 Endmodul + 4 Zwischenmodule + 1 Ausgangsflansch)	• 5 modulos (1 de extremidad + 4 intermediario + 1 brida)	-

Chaque tirant est équipé d'un écrou et d'une rondelle.

Each tie-rod is supplied with 1 nut and 1 washer.

Jeder Verbindungsbolzen wird mit 1 Mutter und 1 Beilagscheibe geliefert.

Cada tirante está equipado con una tuerca y una arandela.

## OPTIONS - ON REQUEST - OPTIONEN - OPCIONES

Ind	#	Désignation	Description	Bezeichnung	Denominación	Qté
12	155 535 700	Ensemble de 2 équerres de fixation	Set of 2 wall mounting brackets	Haltewinkel (Satz mit 2 Stück)	Conjunto de 2 escuadras de fijación	1

<b>Doc. 573.188.050</b> Date/Datum/Fecha : 31/05/16 Annule/Cancel/ Ersetzt/Anula : 22/04/15	<b>Modif. / Änderung :</b> Eclaté / Exploded view / Explosions- zeichnung / Vista + A (1+9+6 → 1-9+6+8a)	<b>Pièces de rechange</b> <b>Spare parts list</b> <b>Ersatzteilliste</b> <b>Piezas de repuesto</b>
--	---	---

<b>VANNE CTM en inox</b> <b>pour changeur de teintes</b>	<b>CTM VALVE (stainless steel)</b> <b>for color changer</b>
<b>CTM FARBEWECHSEL-VENTIL (Edelstahl)</b>	<b>VÁLVULAS CTM de inox</b> <b>para cambiador de color</b>

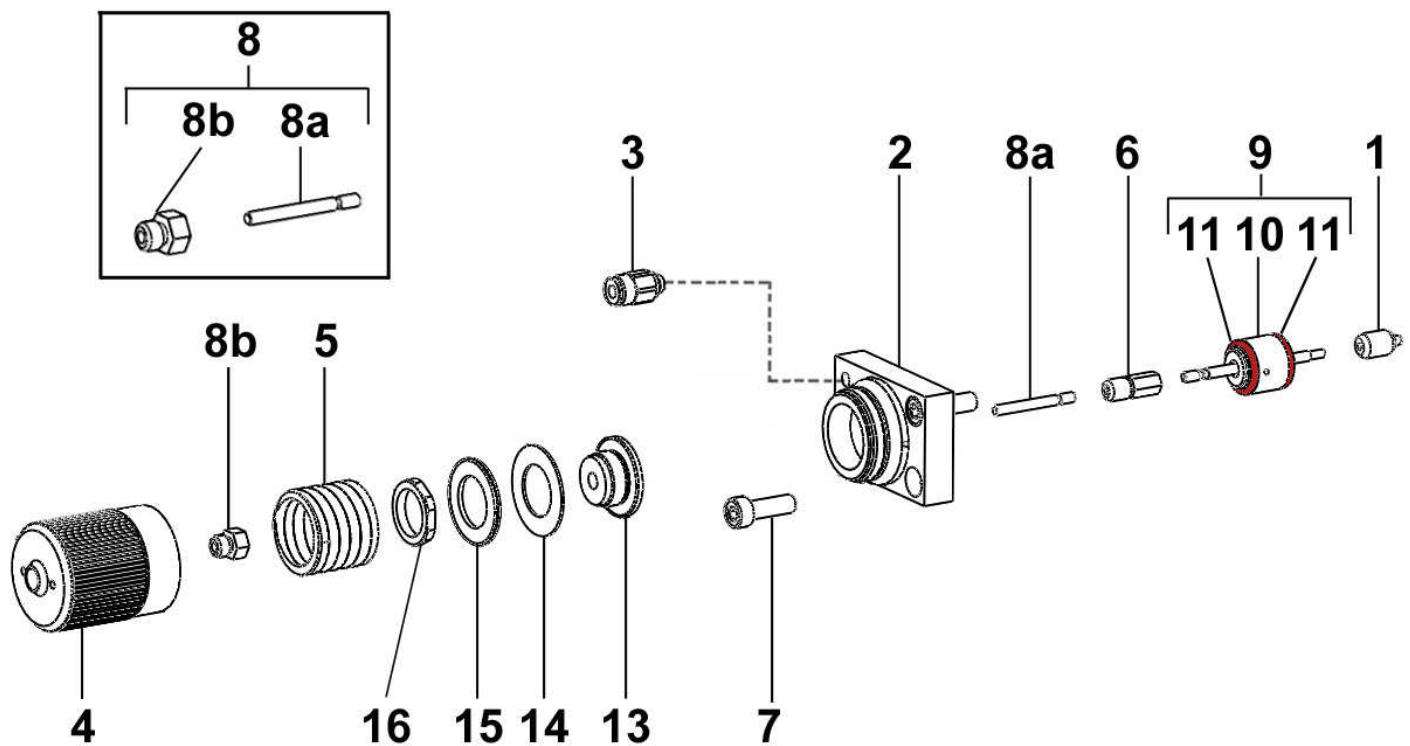

Respecter la **cote de montage A**  
(1+9+6+8a).  
Comply with the dimension value **A**  
(1+9+6+8a).  
Bei der Montage das Maß **A**  
einhalten (1+9+6+8a).  
Cumplir con la cota de montaje **A**  
(1+9+6+8a).

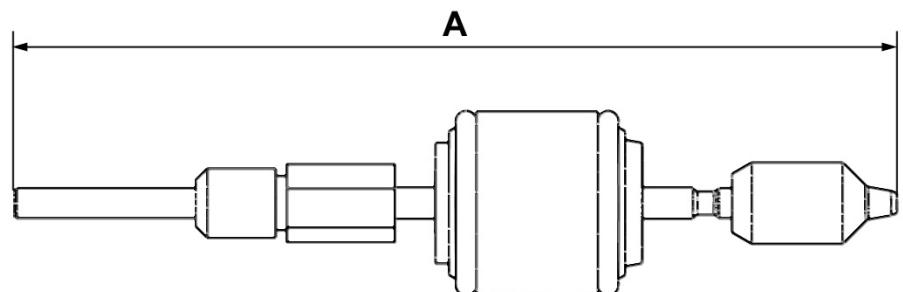

A (mm / ")				
<b>155 535 110</b>	<b>155 535 310</b>	<b>155 535 315</b>	<b>155 528 011</b>	<b>155 536 300</b>
78,5 / 3.09	77 / 3.03	82,9 / 3.26		

VANNE PNEUMATIQUE	AIRSPRAY VALVE	#
NIEDERDRUCK-VENTIL	VÁLVULA NEUMÁTICA	155.535.110
VANNE AIRMIX® 120 bar	AIRMIX VALVE (120 bar / 1740 psi)	#
AIRMIX® - VENTIL (120 bar)	VÁLVULA AIRMIX® 120 bar	155.535.310
VANNE AIRMIX® 200 bar	AIRMIX VALVE (200 bar / 2900psi)	#
AIRMIX® - VENTIL (200 bar)	VÁLVULA AIRMIX® 200 bar	155.535.315
VANNE AIRMIX® GT 200 bar	GT AIRMIX VALVE (200 bar / 2900psi)	#
AIRMIX® - VENTIL GT (200 bar)	VÁLVULA AIRMIX® GT 200 bar	155.528.011

**Pièces communes - Common parts - Gleiche Teile - Partes comunes**

Ind	#	Désignation	Description	Bezeichnung	Denominación	Qté
2	055 535 121	Support cylindre	Support, cylinder	Zylinderhalterung	Soporte cilindro	1
3	905 120 944	Raccord droit M 5 (air commande ouverture)	Air connector, M 5 (control air)	Steckanschluss, M 5 (Steuerluft)	Racor recto M 5 (aire de mando de apertura)	1
6	055 501 003	Entraîneur de tige	Rod carrier	Stangenführung	Arrastre de eje	1
7	933 151 221	Vis CHc M 5 x 16	Screw, model CHc M 5 x 16	Schraube, CHc M 5 x 16	Tornillo, tipo CHc M 5 x 16	3
<b>*9</b>	<b>155 535 140</b>	<b>Cartouche équipée</b>	<b>Cartridge assembly</b>	<b>Packung, kpl</b>	<b>Cartucho equipado</b>	<b>1</b>
10	NC / NS	▪ Cartouche avec tige	▪ Cartridge with rod	▪ Packung mit Stange	▪ Cartucho con eje	1
*11	129 529 918	▪ Joint (les 10)	▪ Seal (pack of 10)	▪ Dichtung (10 St.)	▪ Junta (bolsa de 10)	2
13	029 875 301	Piston seul	Piston only	Kolben, einzeln	Pistón solo	1
*14	029 711 302	Garniture	Packing	Kolbenmanschette	Guarnición	1
15	029 711 303	Rondelle d'appui	Support washer	Scheibe	Arandela de apoyo	1
16	029 711 304	Ecrou M 16 x 100	Nut, model M 16 x 100	Mutter, M 16 x 1,00	Tuerca, tipo M 16 x 100	1

\* Pièces de maintenance préconisées

\* Preceding the index number denotes a suggested spare part.

\* Bezeichnete Teile sind empfohlene Ersatzteile.

\* Piezas de mantenimiento preventivas.

N C : Non commercialisé.

N S : Denotes parts are not serviceable.

N S : Bezeichnete Teile gibt es nur komplett.

N S : no suministrado.

**Pièces spécifiques - Specific parts - Spezifische Teile - Partes específicas**

*	155 535 110	Vanne pneumatique	Airspray valve	Niederdruckventil	Válvula neumática	1
*1	155 501 004	Pointeau	Needle	Nadel	Aguja	1
4	029 711 401	Cylindre	Cylinder	Zylinder	Cilindro	1
5	050 313 504	Ressort	Spring	Feder	Muelle	1
8	155 501 007	Témoin d'ouverture	Valve opening indicator	Schaltzustandsanzeiger	Testigo de apertura	1

*	155 535 310	Vanne AIRMIX® 120 bar	AIRMIX valve (120 bar / 1740 psi)	AIRMIX® Ventil 120 bar	Válvula AIRMIX® 120 bar	1
*1	155 507 013	Pointeau	Needle	Nadel	Aguja	1
4	029 711 401	Cylindre	Cylinder	Zylinder	Cilindro	1
5	050 313 504	Ressort	Spring	Feder	Muelle	1
8	155 501 007	Témoin d'ouverture	Valve opening indicator	Schaltzustandsanzeiger	Testigo de apertura	1

*	155 535 315	Vanne AIRMIX® 200 bar	AIRMIX valve (200 bar / 2900 psi)	AIRMIX® Ventil 200 bar	Válvula AIRMIX® 200 bar	1
*1	155 507 013	Pointeau	Needle	Nadel	Aguja	1
4	055 535 316	Cylindre	Cylinder	Zylinder	Cilindro	1
5	050 316 501	Ressort	Spring	Feder	Muelle	1
8	-	Témoin d'ouverture	Valve opening indicator	Schaltzustandsanzeiger	Testigo de apertura	1
8a	055 501 010	▪ Tige	▪ Rod	▪ Stange	▪ Eje	1
8b	055 501 009	▪ Guide	▪ Guide	▪ Führung	▪ Guía	1

*	155 528 011	Vanne AIRMIX® GT 200 bar	GT AIRMIX valve (200 bar / 2900 psi)	AIRMIX® Ventil GT 200 bar	Válvula AIRMIX® GT 200 bar	1
*1	155 507 013	Pointeau	Needle	Nadel	Aguja	1
4	055 535 316	Cylindre	Cylinder	Zylinder	Cilindro	1
5	050 316 501	Ressort	Spring	Feder	Muelle	1
8	-	Témoin d'ouverture	Valve opening indicator	Schaltzustandsanzeiger	Testigo de apertura	1
8a	055 501 010	▪ Tige	▪ Rod	▪ Stange	▪ Eje	1
8b	055 501 009	▪ Guide	▪ Guide	▪ Führung	▪ Guía	1

<b>VANNE AIRMIX® 200 bar (inox 316 L)</b>	<b>AIRMIX VALVE (200 bar / 2900 psi) (stainless steel, 316 L)</b>	<b>#</b>
<b>AIRMIX® - VENTIL (200 bar), (Edelstahl 316 L)</b>	<b>VÁLVULA AIRMIX® 200 bar (inox 316 L)</b>	<b>155.536.300</b>

**Pièces spécifiques - Specific parts - Spezifische Teile - Partes específicas**

<b>Ind</b>	<b>#</b>	<b>Désignation</b>	<b>Description</b>	<b>Bezeichnung</b>	<b>Denominación</b>	<b>Qté</b>
*1	155 507 014	Pointeau (PEEK)	Needle (PEEK)	Nadel (PEEK)	Aguja (PEEK)	1
4	055 535 316	Cylindre	Cylinder	Zylinder	Cilindro	1
5	050 316 501	Ressort	Spring	Feder	Muelle	1
8	-	Témoin d'ouverture	Valve opening indicator	Schaltzustandsanzeiger	Testigo de apertura	1
	055 501 010	▪ Tige	▪ Rod	▪ Stange	▪ Eje	1
	055 501 009	▪ Guide	▪ Guide	▪ Führung	▪ Guía	1
*9	<b>155 536 350</b>	<b>Cartouche équipée (inox 316 L)</b>	<b>Cartridge assembly, (stainless steel, 316 L)</b>	<b>Packung, kpl (Edelstahl 316 L)</b>	<b>Cartucho (inox 316 L)</b>	<b>1</b>
10	NC / NS	▪ Cartouche avec tige	▪ Cartridge with rod	▪ Packung mit Stange	▪ Cartucho con eje	1
*11	129 529 918	▪ Joint (les 10)	▪ Seal (pack of 10)	▪ Dichtung (10 St.)	▪ Junta (Bolsa de 10)	2

\* Pièces de maintenance préconisées

\* Preceding the index number denotes a suggested spare part.

\* Bezeichnete Teile sind empfohlene Ersatzteile.

\* Piezas de mantenimiento preventivas.

N C : Non commercialisé.

N S : Denotes parts are not serviceable.

N S : Bezeichnete Teile gibt es nur komplett.

N S : no suministrado.

<b>Doc. 573.299.050</b> Date/Datum/Fecha : 10/06/11 Annule/Cancela/ Ersetzt/Anula : 07/10/04	<b>Modif. /Änderung :</b> Mise à jour / Update / Aktualisierung / Actualización	<b>Pièces de rechange</b> <b>Spare parts list</b> <b>Ersatzteilliste</b> <b>Piezas de repuesto</b>
---	---	---

<b>FILTRE PRODUIT HP, modèle 3/8 inox</b>	<b>HP FLUID FILTER, model 3/8 stainless steel</b>
<b>HP MATERIALFILTER, Modell 3/8 Edelstahl</b>	<b>FILTRO PRODUCTO HP, tipo 3/8 inox</b>

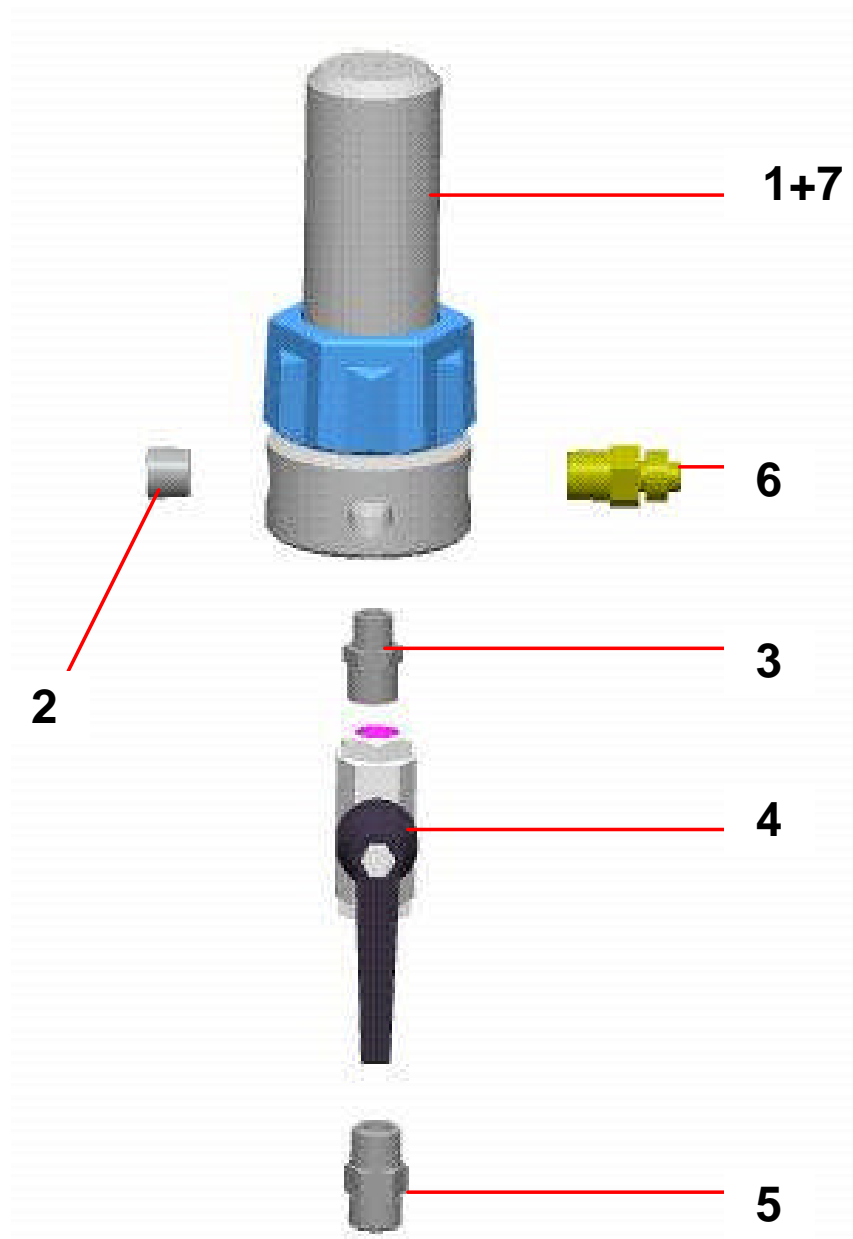



<b>FILTRE EQUIPÉ pour pompes AIRMIX®</b>	<b>FILTRE EQUIPÉ pour pompes AIRLESS®</b>
<b>EQUIPPED FILTER for AIRMIX® pumps</b>	<b>EQUIPPED FILTER for AIRLESS® pumps</b>
<b>AUSGERÜSTETER FILTER für AIRMIX®-Pumpen</b>	<b>AUSGERÜSTETER FILTER für AIRLESS®-Pumpen</b>
<b>FILTRO EQUIPADO para bombas AIRMIX®</b>	<b>FILTRO EQUIPADO para bombas AIRLESS®</b>
<b># 155.580.300</b>	<b># 155.580.400</b>

**PIECES COMMUNES - COMMON PARTS - GLEICHE TEILE - PARTES COMUNES**

Ind	#	Désignation	Description	Bezeichnung	Denominación	Qté
* 1	155.580.200	Filtre nu inox	Bare filter, stainless steel	Nackter Filter - Edelstahl	Filtro solo, inox	1
2	905.210.304	Bouchon inox 3/8 NPT	Plug , stainless steel 3/8 NPT	Blinstopfen - Edelstahl 3/8 NPT	Tapón de inox 3/8 NPT	1
3	906.314.204	Raccord inox M 1/4 - M 3/8	Fitting, double male, 1/4 - 3/8	Doppelnippel AG 1/4 - AG 3/8	Racor inox, M 1/4 - M 3/8	1
* 4	000.750.040	Vanne HP FF 3/8 BSP	HP valve FF 3/8 BSP	Kugelhahn, IG 3/8 BSP	Válvula, HH 3/8 BSP	1
5	050.102.411	Raccord inox M 18 x 125 - M 3/8 BSP	Adaptor, stainless steel, double male 18x125 - 3/8BSP	Doppelnippel - Edelstahl AG 3/8 BSP - M 18x1,25	Racor inox, M 18 x 125 - M 3/8 BSP	1
6	905.210.503	Raccord inox M 3/8 NPT - M 1/2 JIC	Adaptor, stainless steel, double male, 3/8 NPT - # 5 JIC (1/2 JIC)	Doppelnippel Edelstahl 3/8 NPT - 1/2 JIC	Racor, inox M 3/8 NPT - M 1/2 JIC	1

**PIECES SPECIFIQUES - SPECIFIC PARTS - SPEZIELLE TEILE - PARTES ESPECIFICAS**

⇒ **Filtre / Filter / Filtro # 155.580.300**

Ind	#	Désignation	Description	Bezeichnung	Denominación	Qté
* 7	000.161.106	Tamis n° 6 (168 µ)	Screen n° 6 (168 µ - 85 Mesh)	Filterelement Sieb Nr. 6 (168 µ)	Tamiz n° 6 (168 µ)	1

⇒ **Filtre / Filter / Filtro # 155.580.400**

Ind	#	Désignation	Description	Bezeichnung	Denominación	Qté
* 7	000.161.112	Tamis n° 12 (280 µ)	Screen n° 12 (280 µ - 55 Mesh)	Filterelement Sieb Nr. 12 (280 µ)	Tamiz n° 12 (280 µ)	1

- \* Pièces de maintenance préconisées tenues en stock
- \* Preceding the index number denotes a suggested spare part.
- \* Bezeichnete Teile sind empfohlene Ersatzteile.
- \* Piezas de mantenimiento preventivas a tener en stock.

FILTRE NU (sans tamis)	BARE FILTER (without screen)	# 155.580.200
NACKTER FILTER (ohne Sieb)	FILTRO SOLO (sin tamiz)	

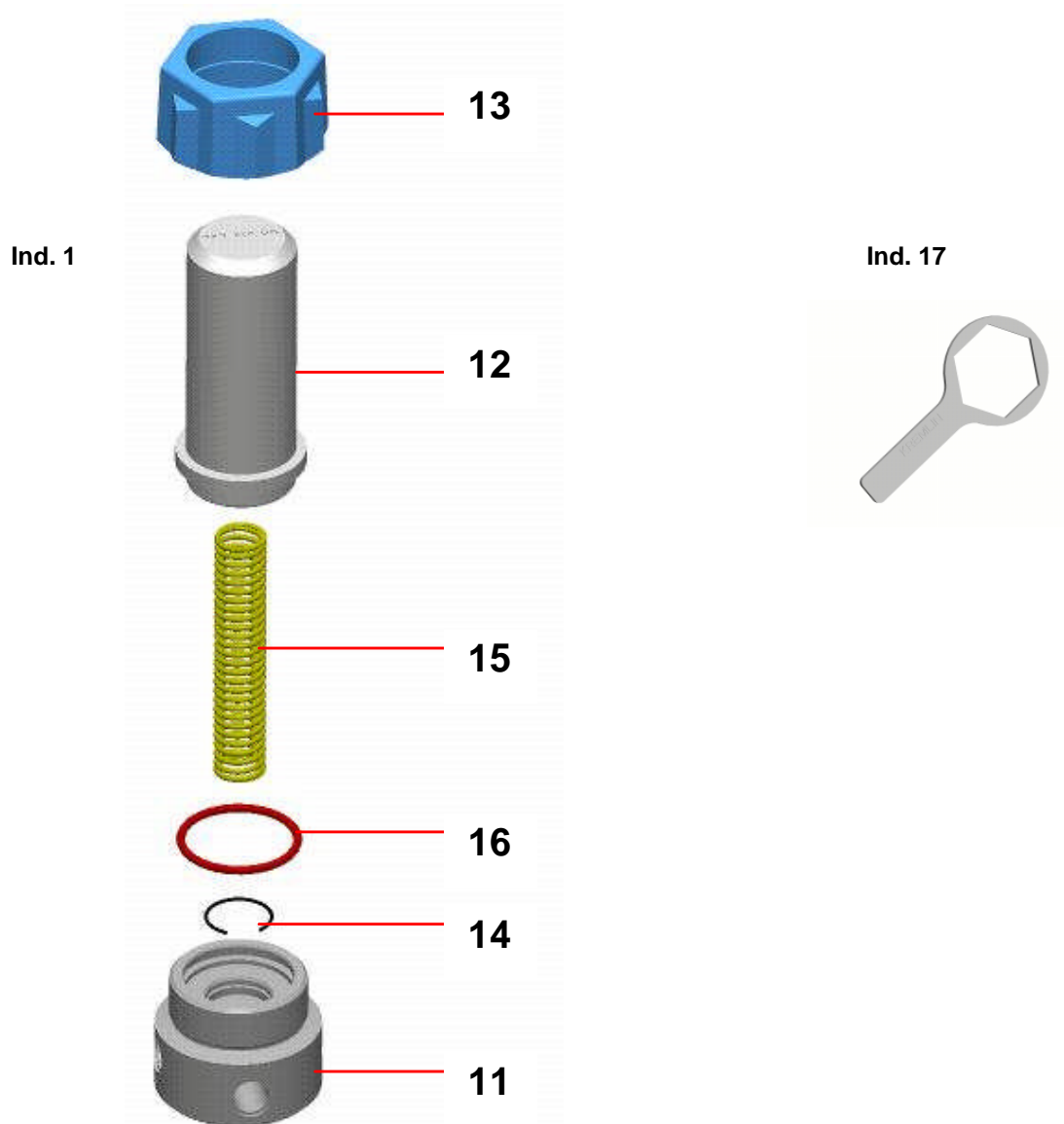

Ind	#	Désignation	Description	Bezeichnung	Denominación	Qté
11	055.580.201	Embase 3/8	Base, model 3/8	Grundblock, Modell 3/8	Base, tipo 3/8	1
12	055.580.202	Cuve	Bowl	Filterglocke	Cubeta	1
13	055.280.002	Ecrou	Nut	Überwurfmutter	Tuerca	1
14	055.190.007	Jonc	Stop ring	Sicherungsring	Clips	1
15	055.190.005	Ressort	Spring	Feder	Muelle	1
* 16	150.040.327	Joint (les 5)	Seal (pack of 5)	Dichtung (5 St.)	Junta (bolsa de 5)	1
17	049.030.018	Clé de démontage	Wrench	Schlüssel	Llave de desmontaje	1

A LA DEMANDE - ON REQUEST - AUF WUNSCH - A PETICIÓN

Ind. 7



Ind	#	Désignation	Description	Bezeichnung	Denominación	Qté
-	000.161.101	Tamis n° 1 (37 µ)	Screen n° 1 (37 µ)	Sieb Nr. 1 (37 µ)	Tamiz n° 1 (37µ)	1
-	000.161.102	Tamis n° 2 (77 µ)	Screen n° 2 (77 µ)	Sieb Nr. 2 (77 µ)	Tamiz n° 2 (77 µ)	1
-	000.161.104	Tamis n° 4 (99 µ)	Screen n° 4 (99 µ)	Sieb Nr. 4 (99 µ)	Tamiz n° 4 (99 µ)	1
<b>7</b>	<b>000.161.106</b>	<b>Tamis n° 6 (168 µ)</b>	<b>Screen n° 6 (168 µ)</b>	<b>Sieb Nr. 6 (168 µ)</b>	<b>Tamiz n° 6 (168 µ)</b>	<b>1</b>
-	000.161.108	Tamis n° 8 (210 µ)	Screen n° 8 (210 µ)	Sieb Nr. 8 (210 µ)	Tamiz n° 8 (210 µ)	1
<b>7</b>	<b>000.161.112</b>	<b>Tamis n° 12 (280 µ)</b>	<b>Screen n° 12 (280 µ)</b>	<b>Sieb Nr. 12 (280 µ)</b>	<b>Tamiz n° 12 (280 µ)</b>	<b>1</b>
-	000.161.115	Tamis n° 15 (360 µ)	Screen n° 15 (360 µ)	Sieb Nr. 15 (360 µ)	Tamiz n° 15 (360 µ)	1
-	000.161.020	Tamis n° 20 (510 µ)	Screen n° 20 (510 µ)	Sieb Nr. 20 (510 µ)	Tamiz n° 20 (510 µ)	1
-	000.161.030	Tamis n° 30 (750 µ)	Screen n° 30 (750 µ)	Sieb Nr. 30 (750 µ)	Tamiz n° 30 (750 µ)	1

OPTIONS - ON REQUEST - OPTIONEN - OPCIONES

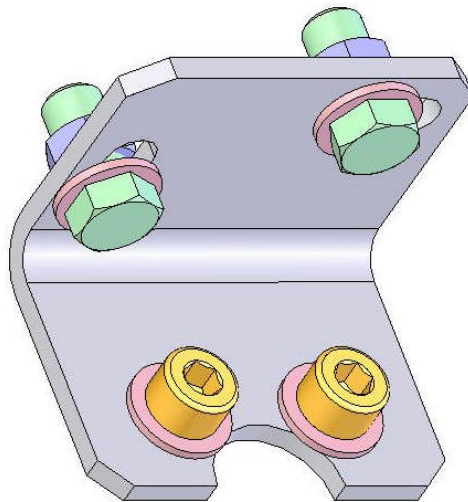

Ind	#	Désignation	Description	Bezeichnung	Denominación	Qté
-	155.190.105	Support filtre avec vis, rondelles et écrous	Mounting bracket with screws, washers and nuts	Filterhalterung mit Schrauben, Scheiben und Muttern	Soporte filtro con tornillos, arandelas y tuercas	1

<b>Doc. 573.457.050</b> Date/Datum/Fecha : 21/05/14 Annule/Cancel/ Ersetzt/Anula :	<b>Modif. / Änderung :</b>	<b>Pièces de rechange</b> <b>Spare parts list</b> <b>Ersatzteilliste</b> <b>Piezas de repuesto</b>
---	----------------------------	---

<b>POMPE DE RINCAGE          POUR POMPE PU 3000,          modèle EOS 02-C85</b>	<b>FLUSHING PUMP          FOR PU 3000 PUMP,          model EOS 02-C85</b>
<b>SPÜLPUMPE          FÜR PU 3000 PUMPE,          Modell EOS 02-C85</b>	<b>BOMBA DE LIMPIEZA          PARA BOMBA PU 3000,          tipo EOS 02-C85</b>

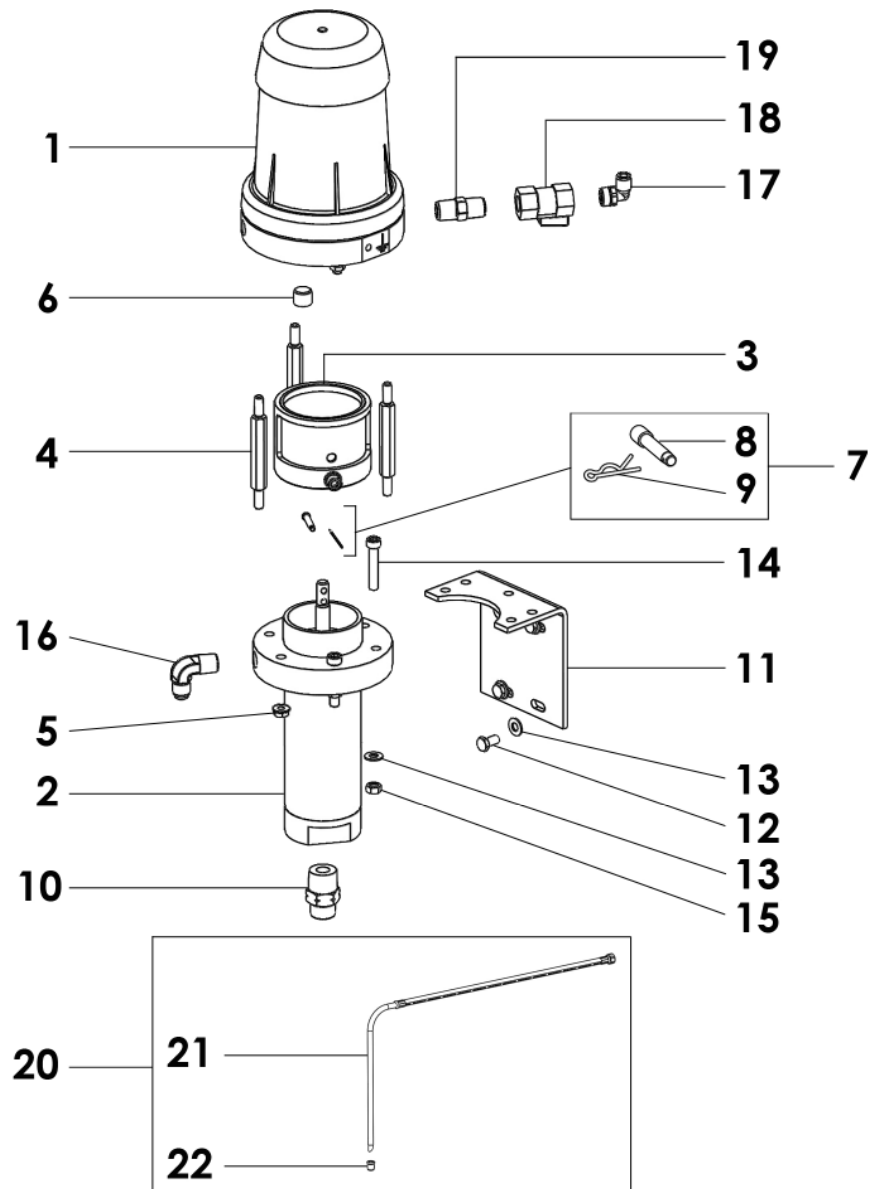
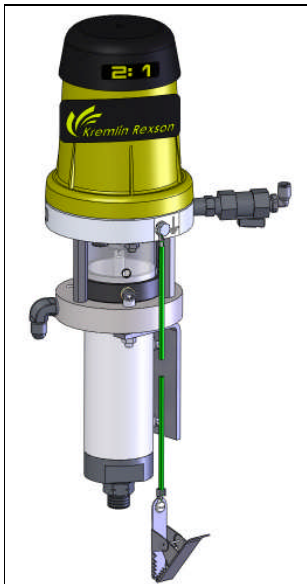

<b>POMPE DE RINÇAGE POUR POMPE PU 3000, modèle EOS 02-C85</b>	<b>FLUSHING PUMP FOR PU 3000 PUMP, model EOS 02-C85</b>	<b>#</b>  <b>155.680.170</b>
<b>SPULPUMPE FÜR PUMPE PU 3000, Modell EOS 02-C85</b>	<b>BOMBA DE LIMPIEZA PARA BOMBA PU 3000, tipo EOS 02-C85</b>	

Ind	#	Désignation	Description	Bezeichnung	Denominación	Qté
*-	144 940 000	Pompe nue inox (voir Doc. 573.022.050)	Bare pump, stainless steel (refer to Doc. 573.022.050)	Nackte Pumpe, Edelstahl (siehe Dok. 573.022.050)	Bomba sola inox (consultar Doc. 573.022.050)	1
*1	144 855 600	▪ Moteur 340-2 EOS (voir Doc. 573.419.050)	▪ Air motor, model 340-2 EOS (refer to Doc. 573.419.050)	▪ Luftmotor, Modell 340-2 EOS (siehe Dok. 573.419.050)	▪ Motor, tipo 340-2 EOS (consultar Doc. 573.419.050)	1
*2	144 940 010	▪ Hydraulique C85 inox (voir Doc. 573.024.050)	▪ Fluid section, model C85 stainless steel (refer to Doc. 573.024.050)	▪ Hydraulikteil, Modell C85 Edelstahl (siehe Dok. 573.024.050)	▪ Hidráulica, tipo C85 inox (consultar Doc. 573.024.050)	1
*3	144 940 020	▪ Carter de protection	▪ Protection housing	▪ Schützgehäuse	▪ Cártar de protección	1
4	044 580 007	▪ Tirant	▪ Tie-rod	▪ Stehbolzen	▪ Tirante	3
5	906 011 501	▪ Erou frein M 6	▪ Nut, model M 6	▪ Blockiermutter, M 6	▪ Tuerca freno, tipo M 6	3
6	906 333 102	▪ Bouchon 1/4" G	▪ Plug, model 1/4" G	▪ Verschlussstopfen 1/4" G	▪ Tapón, tipo 1/4" G	1
*7	144 850 152	▪ Ensemble accouplement	▪ Coupling kit	▪ Kupplungssatz	▪ Conjunto acoplamiento	1
8	NC / NS	• Axe	• Axis	• Achse	• Eje	1
9	NC / NS	• Goupille	• Pin	• Splint	• Pasador	1
10	050 102 418	Raccord inox MM 1/2" - 18 x 125	Adapter, double male, (stainless steel), model 1/2" - 18 x 125	Nippel, Edelstahl AG 1/2" - M 18 x 1,25	Racor inox, tipo MM 1/2" - 18 x 125	1
11	NC / NS	Support mural	Pump bracket	Wandhalter	Soporte de bomba	1
12	NC / NS	Vis H 6 x 12	Screw, model H 6 x 12	Schraube, H 6 x 12	Tornillo, tipo H 6 x 12	4
13	963 040 016	Rondelle MU 6	Washer, model MU 6	Mutter, MU 6	Arandela, tipo MU 6	6
14	933 151 443	Vis CHc M 6 x 35	Screw, model CHc M 6 x 35	Schraube, CHc M 6 x 35	Tornillo, tipo CHc M 6 x 35	2
15	NC / NS	Erou HM 6	Nut, model HM 6	Mutter, HM 6	Tuerca, tipo HM 6	2
16	905 210 602	Raccord coudé M 1/4 NPT - M 1/2 JIC	Elbow connector, M 1/4 NPT - M 1/2 JIC	Winkelnippel AG 1/4 NPT - AG 1/2 JIC	Racor acodado, M 1/4 NPT - M 1/2 JIC	1
17	905 120 905	Raccord coudé 1/4" G - T 4 x 6	Elbow connector 1/4" G - T 4 x 6	Winkel Stecknippel 1/4" G - T 4 x 6	Racor acodado, 1/4" G - T 4 x 6	1
18	903 090 806	Vanne FF 1/4" G	Valve, model FF 1/4" G	Absperrhahn IG/IG 1/4" G	Válvula, tipo HH 1/4" G	1
19	906 314 203	Raccord (inox 316L) MM 1/4 BSP	Fitting, double male, 1/4" BSP (316L stainless steel)	Doppelnippel AG/AG 1/4" BSP (Edelstahl, 316L)	Racor (inox 316L) MM 1/4 BSP	1
-	905 120 903	Té T 4 x 6	Tee, model T 4 x 6	T-Stück T 4 x 6	Te, tipo T 4 x 6	1

Ind	#	Désignation	Description	Bezeichnung	Denominación	Qté
20	049 596 010	Canne d'aspiration inox équipée	Suction rod, stainless steel assembly	Ansaugschlauch, Edelstahl Kpl.	Caña de aspiración de inox equipada	1
21	NC / NS	▪ Canne d'aspiration inox Ø 16	▪ Suction rod, model Ø 16 (stainless steel)	▪ Ansaugschlauch, Edelstahl, Ø 16	▪ Caña de aspiración de inox, tipo Ø 16	1
22	051 531 600	▪ Crépine Ø 17	▪ Strainer assembly, model Ø 17	▪ Siebkörbe, Ø 17	▪ Piña, tipo Ø 17	1
-	050 450 651	Tuyau produit (Ø 4,8 mm, long. 0,6 m, raccords inox, 240 bar)	Fluid hose (3/16" dia, 0.6 m long, stainless steel hoses, 240 bar / 3481 psi)	Materialschlauch (Ø 4,8 mm, Länge: 0,6 m, Anschlüsse Edelstahl, 240 bar)	Tubería producto (Ø 4.8 mm, 0,6 m de largo, racores de inox, 240 bar)	1
-	NC / NS	Tuyau 4 x 6 Longueur : 1,20 m	Hose 4 x 6 Length : 1.20 m / 47.24"	Schlauch 4 x 6 Länge : 1,20 m	Tubería 4 x 6 Longitud : 1,20 m	1
-	149 990 020	Flacon de lubrifiant T (125 ml)	T lubricant (125 ml / 4.4 oz)	Spülmittel T (125 ml)	Botella de lubricante T (125 ml)	1

\* Pièces de maintenance préconisées.

\* Preceding the index number denotes a suggested spare part.

\* Bezeichnete Teile sind empfohlene Ersatzteile.

\* Piezas de mantenimiento preventivas.

N C : Non commercialisé.

N S : Denotes parts are not serviceable.

N S : Bezeichnete Teile gibt es nicht einzeln, sondern nur komplett .

N S : no suministrado.

# PU 3000

## PU 3000

# PU 3000

## PU 3000



220 V  
1 ph  
1A

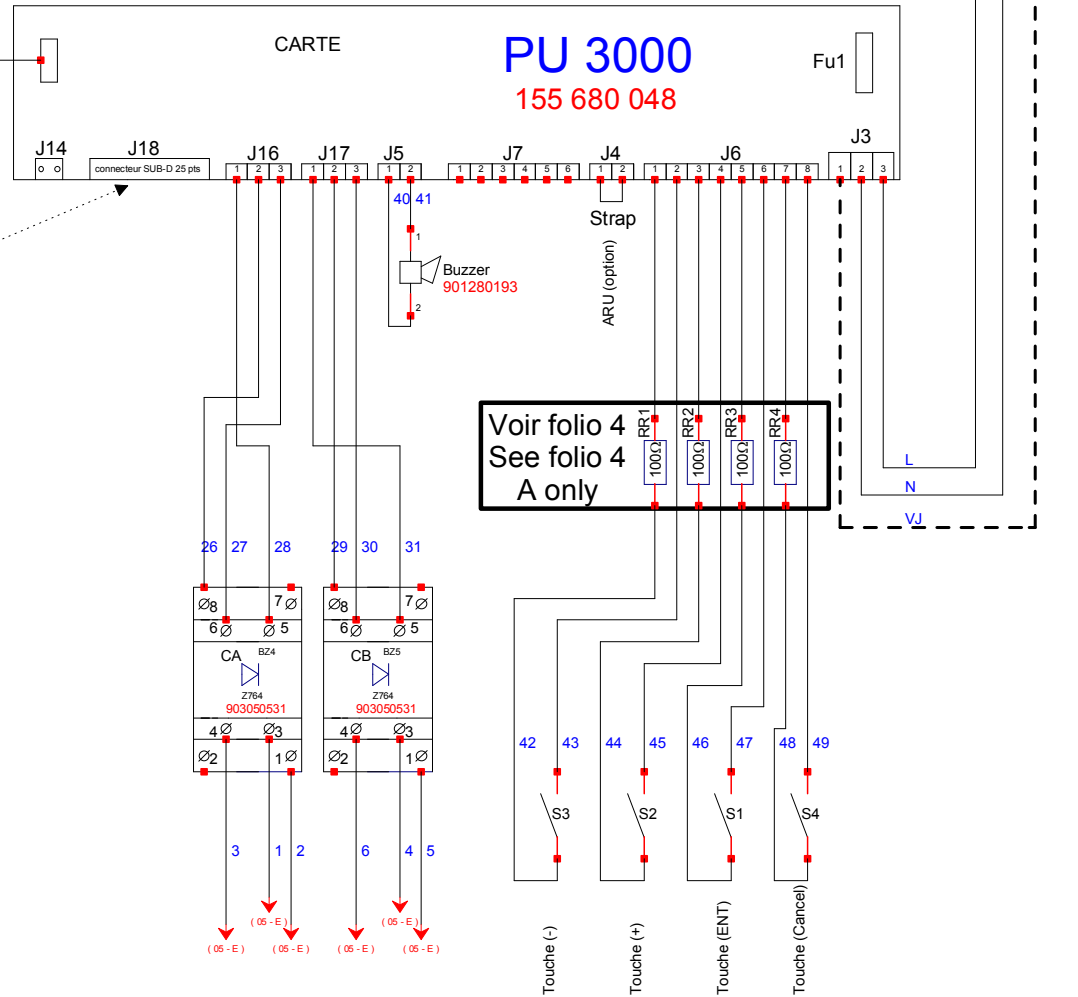
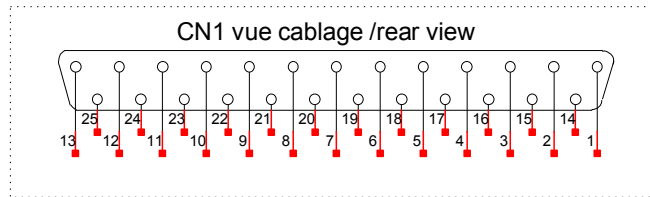
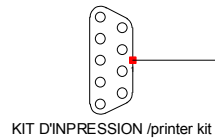
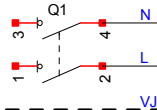

Voir folio 4  
See folio 4  
A only

SUB D 25	
1	+24V
2	0V
14	IN
15	+24V
16	0V
3	IN
6	0V
18	+24V(OUT)
9	0V
21	+24V(OUT)
10	0V
22	+24V(OUT)
7	0V
19	+24V(OUT)
8	0V
20	+24V(OUT)
11	IN
23	+24V
12	0V
24	+24V(OUT)
13	0V
25	+24V(OUT)

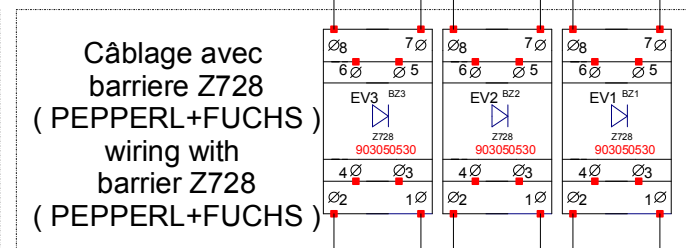
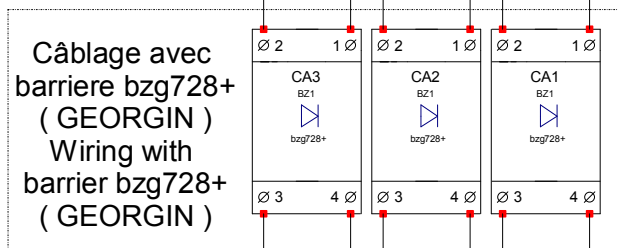
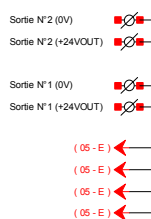
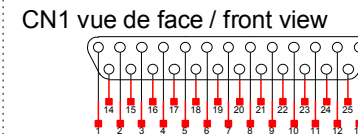
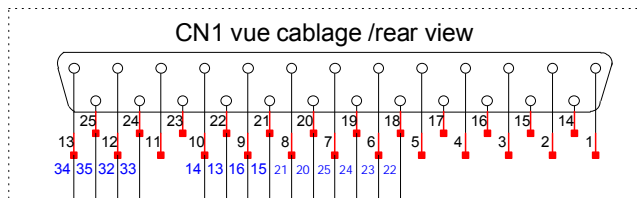

**Le câblage avec barriere bzg728+ ( GEORGIN ) et le câblage avec barriere Z728 ( PEPPERL+FUCHS ) l'un annule l'autre**  
**For IS barrier you need to select the wiring diagram depending of IS barrier used**

(05 - E) (05 - E) (05 - E) (05 - E)

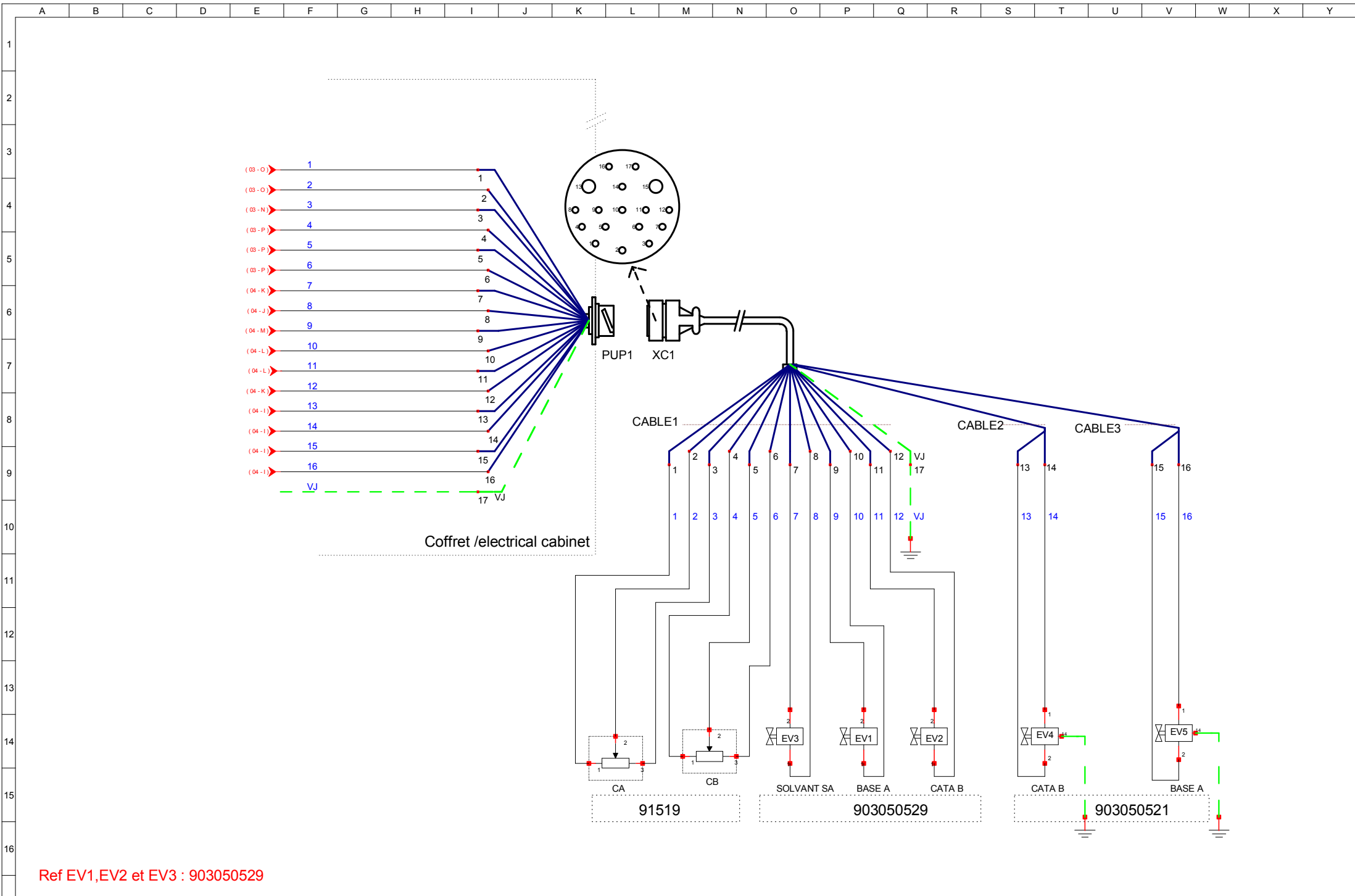

Ref EV1, EV2 et EV3 : 903050529

# A

Ancienne carte Electronique  
Sans led et résistance  
Electronic board  
Without DEL resistor

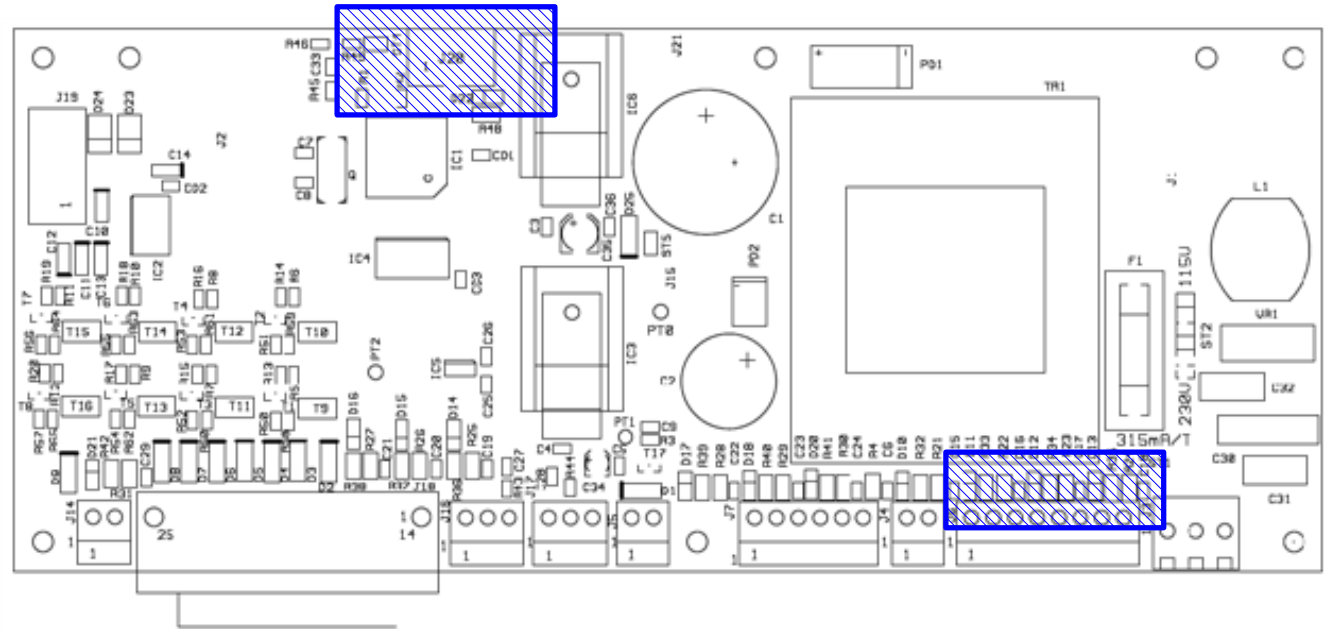

Nouvelle carte Electronique  
Avec led et résistance  
New electronic board  
With DEL resistor

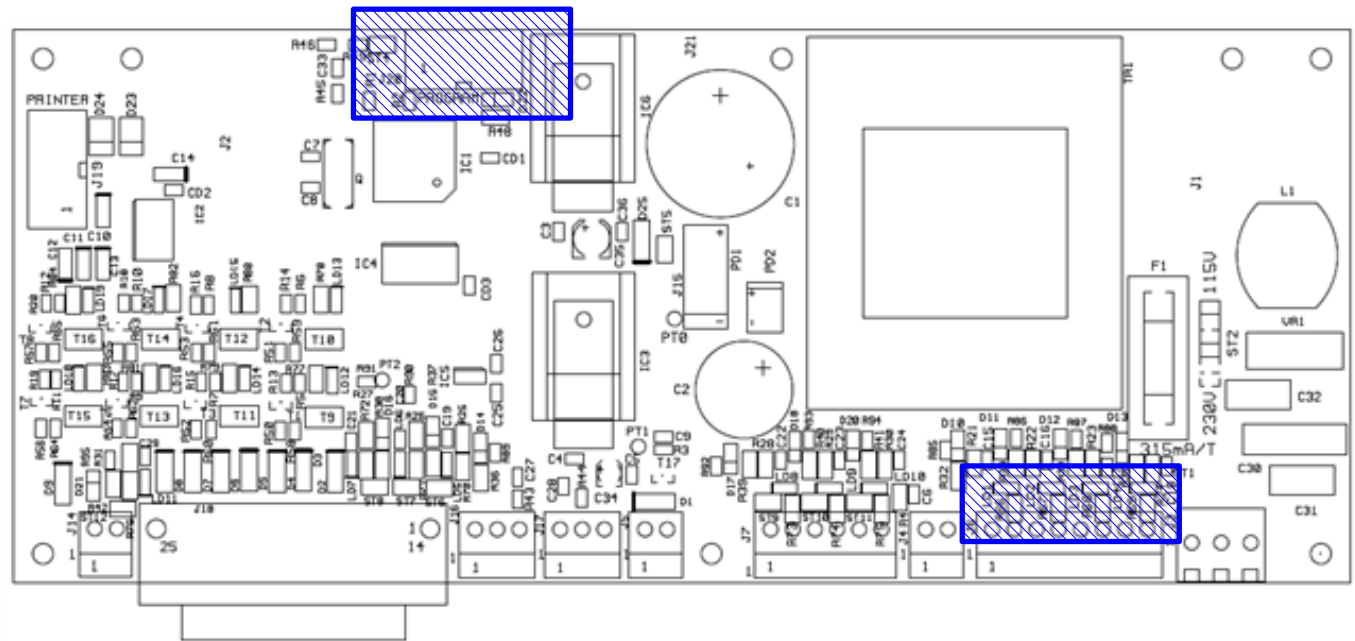

# PU 3000

## PU 3000

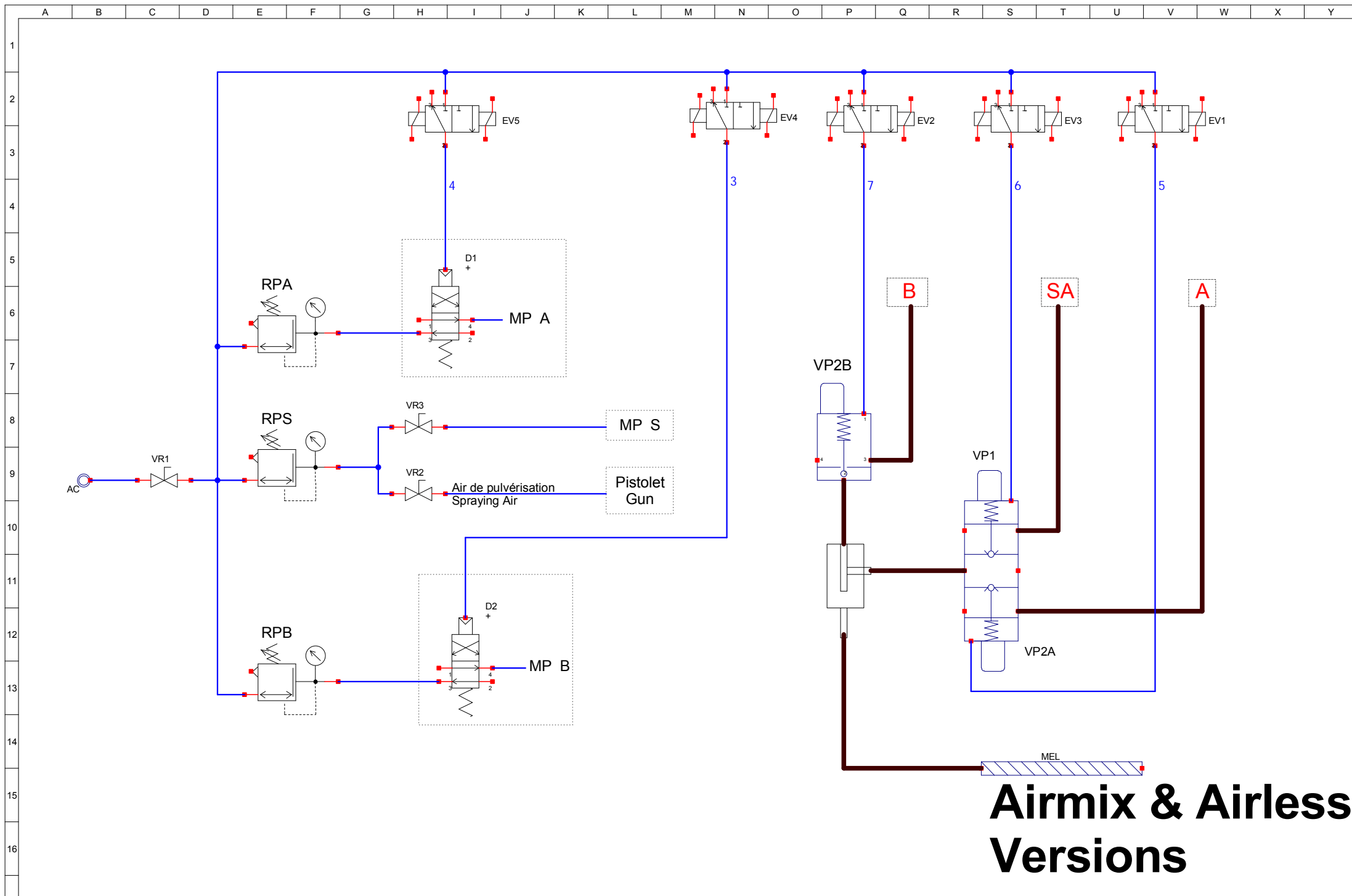

# Airmix & Airless Versions

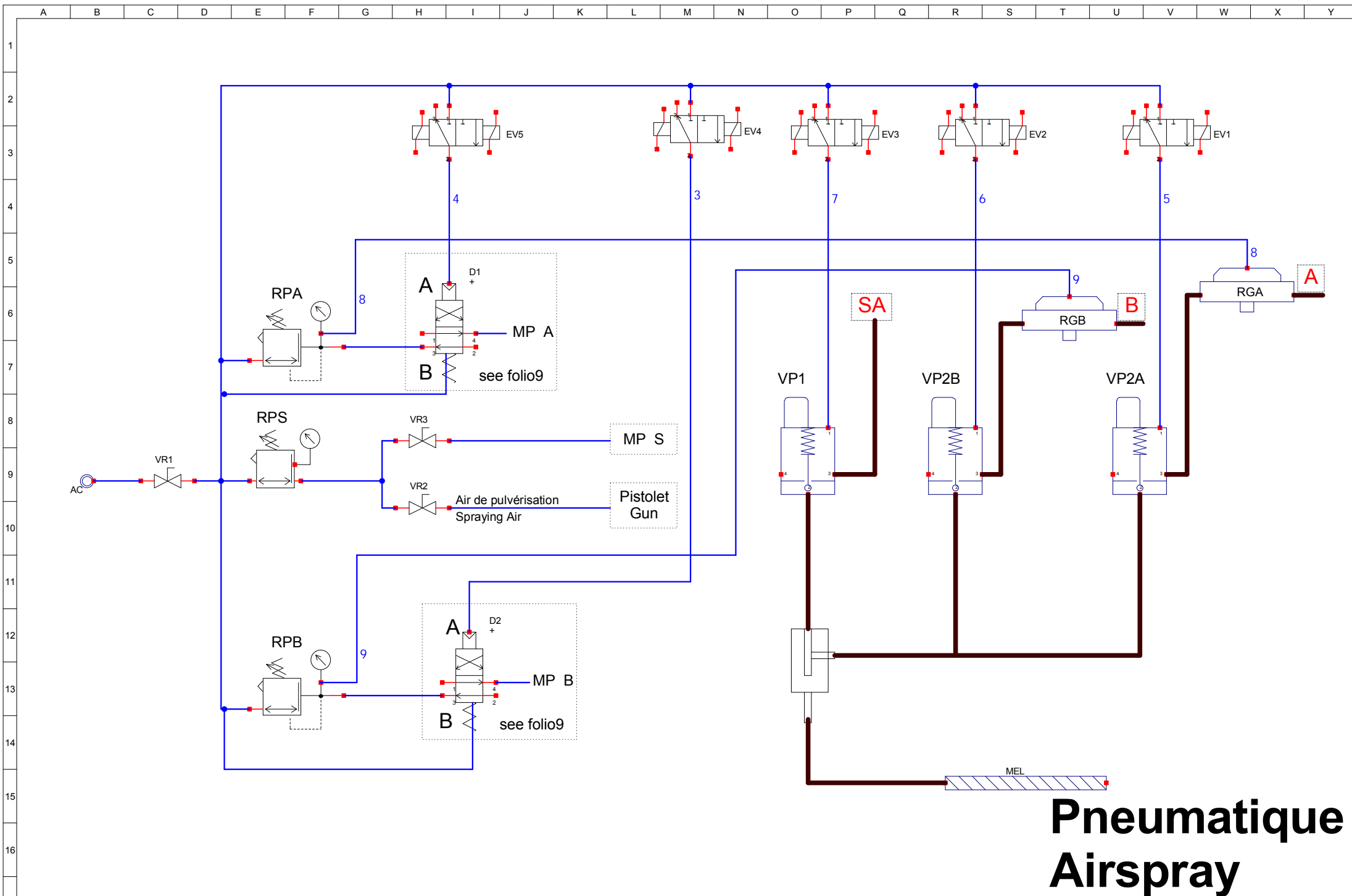

# Pneumatique Airspray

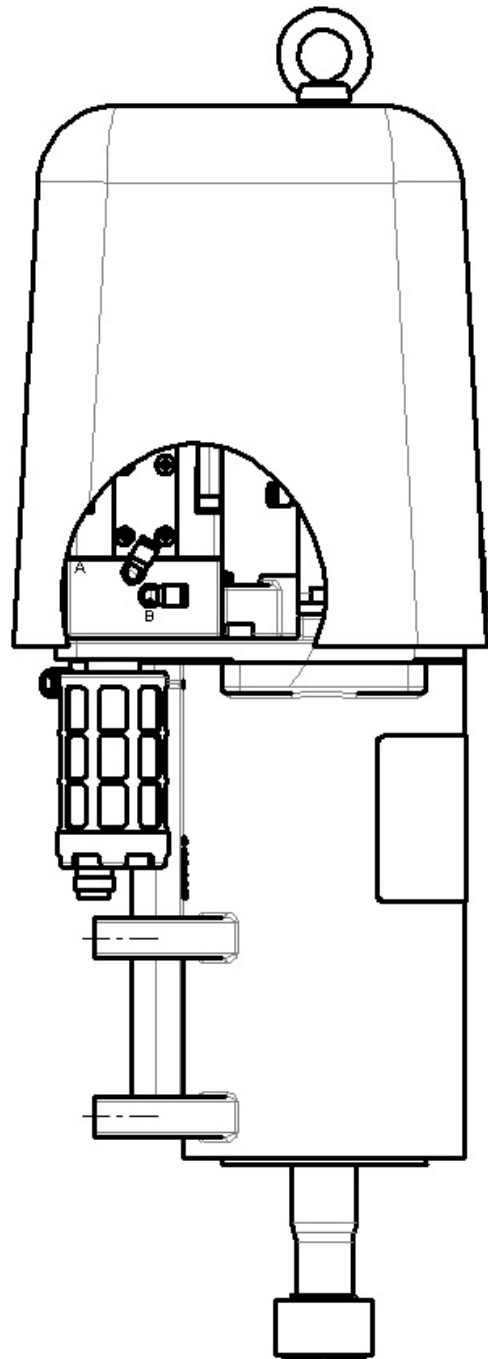

# Pneumatique Airspray