



From February 1st, 2017 SAMES Technologies SAS becomes SAMES KREMLIN SAS
A partir du 1/02/17, SAMES Technologies SAS devient SAMES KREMLIN SAS

SAMES  **KREMLIN**



User manual

FCG Metering Gear Pumps 3 - 6 and 10 cc

SAS SAMES Technologies. 13 Chemin de Malacher -
Inovallée - CS 70086 - 38243 Meylan Cedex France
Tel. 33 (0)4 76 41 60 60 - Fax. 33 (0)4 76 41 60 90 - www.sames.com

All communication or reproduction of this document, in any form whatsoever and all use or communication of its contents are forbidden without express written authorisation from SAMES Technologies.

The descriptions and characteristics mentioned in this document are subject to change without prior notice.

© SAMES Technologies 2014



WARNING : SAS Sames Technologies is registered with the Ministry of Labour as a training institution.

Throughout the year, our company offers training courses in the operation and maintenance of your equipment.

A catalogue is available on request. Choose from a wide range of courses to acquire the skills or knowledge that is required to match your production requirements and objectives.

Our training courses can be delivered at your site or in the training centre at our Meylan head office.

Training department:

Tel. 33 (0)4 76 41 60 04

E-mail: formation-client@sames.com

SAS Sames Technologies operating manuals are written in French and translated into English, German, Spanish, Italian and Portuguese.

The French version is deemed the official text and Sames will not be liable for the translations into other languages.

FCG Metering Gear Pumps

3 - 6 and 10 cc

1. Health and Safety Instructions	4
1.1. Marking	4
1.2. Simplified analysis of the potential sources of ignition according to Standard EN 13463-1	4
1.3. Precautions for Use	5
1.4. Warnings	5
1.5. Insulation or Grounding	6
2. Description	7
3. Characteristics	8
3.1. General Characteristics	8
3.2. Dimensions	9
4. Installation	10
4.1. General Information	10
4.2. Installation	10
4.3. Sequence, Fluid diagrams and Process cycles	11
4.3.1. Assembly installed on the robot arm with sprayer without coil.	11
4.3.2. Assembly installed on the robot arm with sprayer with coil	13
5. Operating	15
5.1. Tools	15
5.2. Breaking in the new pump	16
6. Maintenance	17
6.1. Replacement of the Upvalve on the shunt block	17
6.2. Pump	18
6.2.1. Disassembly Procedure	18
6.2.2. Reassembly Procedure	22
7. Cleaning	28
8. Troubleshooting	29
9. Spare parts	30
9.1. FCG equipped pumps	30
9.1.1. Shunt block	31
9.2. FCG Pumps	33
9.3. Maintenance kits for FCG pumps	34
9.4. Connecting Flanges	35

1. Health and Safety Instructions

1.1. Marking

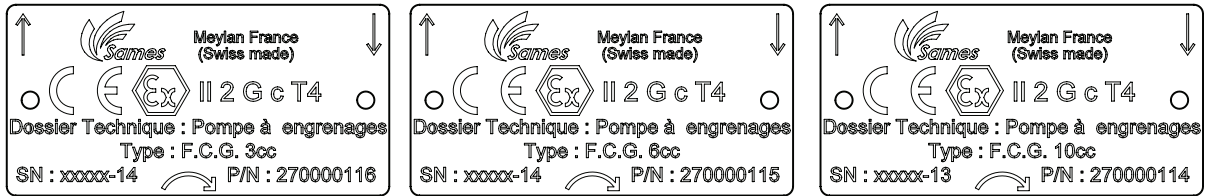

Remark: The arrow shows the direction of the pump.



WARNING : It is imperative to respect the direction of rotation indicated on the pump.

1.2. Simplified analysis of the potential sources of ignition according to Standard EN 13463-1

Risk of ignition		Action applied to prevent any ignition source to become effective
Potential source of ignition	Description / Main cause (What are the conditions engendering the ignition risk?)	Description of the applied action
Hot surface	Warm-up of the exterior surface of the pump due to a temperature of the metered fluid or to mechanical frictions or to an excessive speed.	Test to define the maximum temperature of surface
Spark of a mechanical origin	Friction of the gears and axes	Rotation speed is lower than 1m/s, (see § 3.1 page 8).
Electrostatic discharge	Incorrect grounding	Electrostatic discharge is impossible because all the parts of the pump are metallic and are connected between them, (see § 1.5 page 6)
Electrostatic discharge	Insulated pump	For an electrostatic installation, respect the rules: see § 1.5 page 6 .

1.3. Precautions for Use

This document contains information that all operators should be aware of and understand before using this material. This information highlights situations that could result in serious damage and indicates the precautions that should be taken to avoid them. The equipment must only be used by personnel trained by SAMES Technologies.

1.4. Warnings



WARNING : Safety may be jeopardized if this equipment is not operated, disassembled and reassembled in compliance with the instructions given in this manual and in any European Standard or national safety regulations in force.



WARNING : Equipment performance is only guaranteed if original spare parts distributed by SAMES Technologies are used.

Pump assemblies must be kept clean so that it is possible to detect any leaks and their severity.

Electrostatic spraying equipment must be serviced regularly in accordance with the information and instructions given by SAMES Technologies. The pump specifications must be observed carefully.

Cleaning operations must be carried out either in authorised areas equipped with a mechanical ventilation system, or using cleaning liquids with a flash point at least 15 °C higher than room temperature.

The operator must use the protections adapted for the eyes and the skin when the proportioned product presents dangers.

After having carried out repairs, adjustments or cleaning with polluting products, a particular care will be taken to the ecological elimination of waste.

It is strictly forbidden to any operator to interfere on equipment under operation.



WARNING :

- Before any maintenance operation, please rinse thoroughly with the proper rinsing solution before each time the pump is taken apart and make sure that no pressure positive or negative remains and complete the cycle by prolonged blowing (4 to 5 seconds).
- Switch off the solvent supplies and decompress the circuits.
- Switch then the power supply of the motor-pump group to avoid any putting in inconvenient rotation during the intervention.

Any modification of the pump being able to decrease the operating safety is prohibited.

The pump must be used in a surrounding area clear and clean.

Only metal containers can be used for cleaning liquids and they must have a reliable ground connection

The storage of the pumps or its components must be done in a dry room and safe from dust.

Before the installation of the pump, it is important to store it, as a preliminary, at the temperature to which the pump will be used in order to avoid any risk of seizing.

1.5. Insulation or Grounding

Use of these pumps with conductive products must comply with the rules concerning electrical insulation and enclosure-access reserved for this material. The possibility of the access to the enclosure must be checked to the switch-off of the high voltage in order to avoid any risk of electric shocks to the people. In all cases, the connection equipment must comply with the characteristics relative to the transport of pressurised liquid products up to 50 bar.

Pumping of conductive products and presence of **HV**:

- The configuration of the installation will be established by SAMES specialists.
- Any modification without consultation will result in the invalidity of the certificate of conformity.

Pumping of insulating products with or without the presence of **HV**:

- It is necessary to connect the pump to the ground with the connection screw located on the pump.

2. Description

This pump is designed especially for the metering of paints and products no-charged (Viscosity of 20 to 200 mPas).

All parts in contact with the paint are coated with ADLC.

The normal life under optimal parameters is about 2 years at a rate of 5 days per week and 8 hours per day. This value is given as an indication because it can change according to the metered product.

Product input and output are located on the pump body. The product to be metered is guiding from the opening to the gears. The set of teeth fills up and drives the product to the exit. The set of teeth empties when the gear turns and pushes the product through the output opening by decompression.

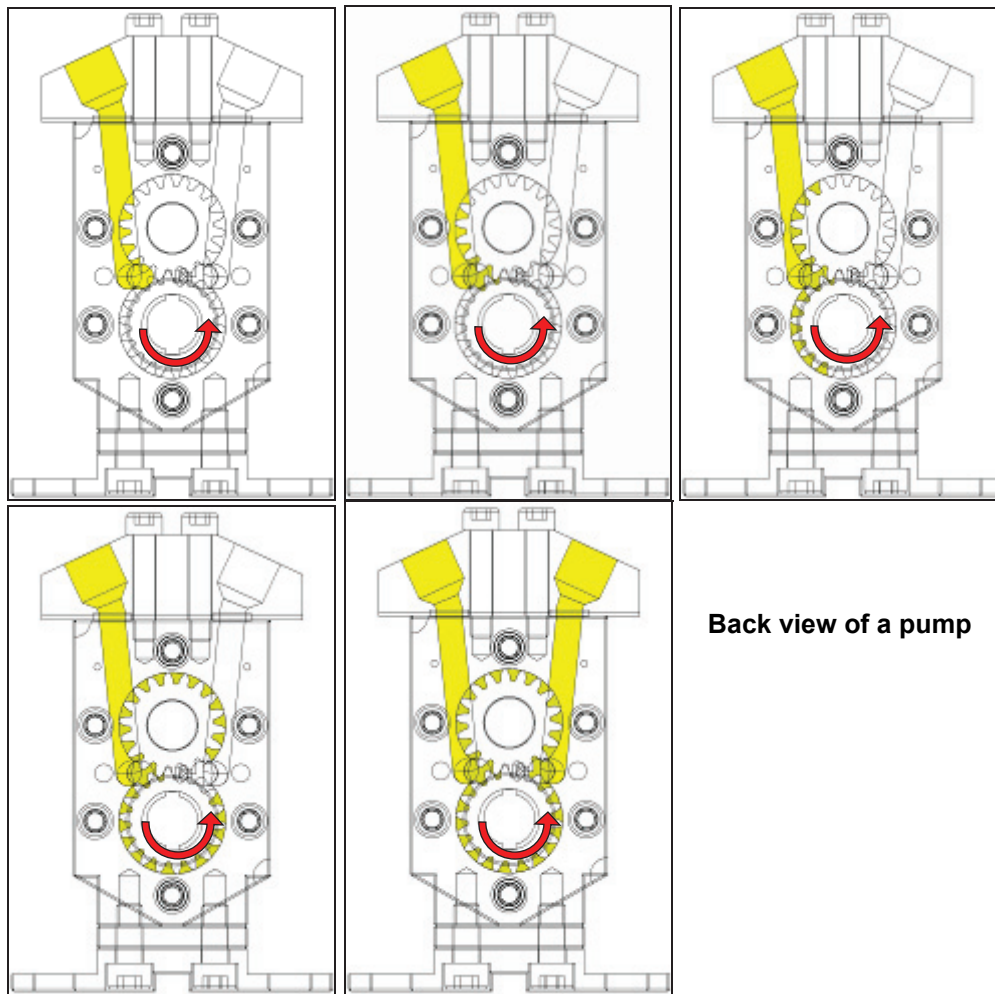

DES06070

3. Characteristics

3.1. General Characteristics

- Pressures
 - optimal: 3 to 7 bars short 15 bars.
 - ΔP limit: 2 bars
 ΔP : output pressure - input pressure.
Higher ΔP increases the wear of the pump and decreases the accuracy of the metering.
- Rotation speed.: from 10 rpm to 80 rpm depending on the product (best results obtained between 30 and 80 rpm).
 - Rinsing: Maximum 40 rpm, by pass open.



WARNING : It is imperative to respect the direction of rotation indicated on the pump.

- Temperature of the metered fluid: 60°C max. for an ambient temperature between -20°C and 40°C.
- Dosage accuracy.
The accuracy of the dosage of a new pump is between $\pm 2\%$ within the following operation conditions:
 - Rotation speed between 30 and 80 rpm.
 - Rinsing oil viscosity of 25s DIN 4
 - Delta P ± 2 bar between input and output.

3.2. Dimensions

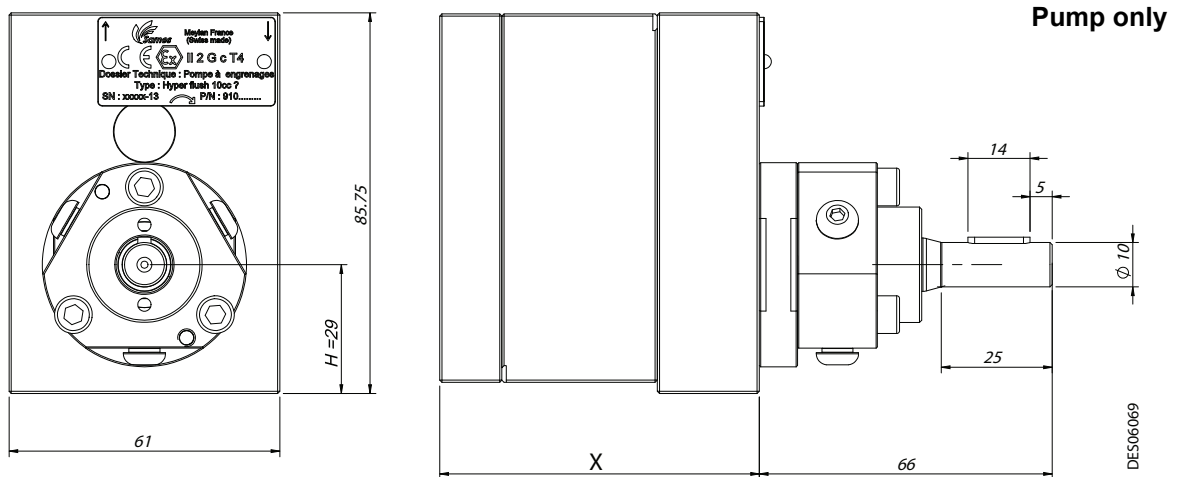

Equipped pump

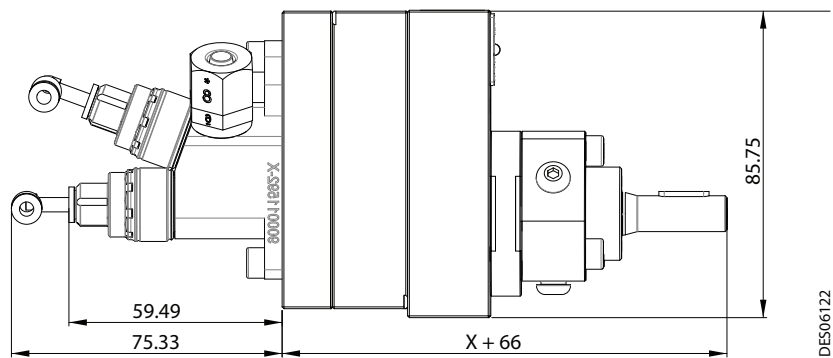

Dimensions are in mm.

Size	3 cc	6 cc	10 cc
X (mm)	47,5	58	72
Weight of pump only	1.91 Kg	2.1 Kg	2.88 Kg
Weight of equipped pump	2.2 Kg	2.35 Kg	3.15 Kg

4. Installation

4.1. General Information

It is advised to clean the pump before its assembly. The inlets / outlets must be free from any impurities which could block the openings. Observe the direction of the rotation as well as the inlets/ outlets indicated on the pump. Turn manually the axis of the pump of some turns in order to check the rotation.



WARNING : Turning the axle of the pump in the bad direction can cause damage and destroy the pump. The direction of rotation of the pump indicated on the pump is defined by positioning the drive-shaft in the direction of the observer.
It is also advised NOT to run the pump dry.

4.2. Installation

Elements linked to pump operation:

- The pump must be correctly installed on its stand. A perfect alignment between the pump shaft and the drive shaft must be respected. A minimum distance of 2 mm between the tip of drive shaft and the pump should be kept and the two should never touch. A radial pressure on the drive shaft can damage the pump.
- For leak proof connections, use rigid seals in PTFE.
- Check the hoses before and after the pump. In case of impurities at the entrance of the pump or if the product to be metered is not perfectly clean, a filter must be installed.
- The pump must not be in contact with any other element of the installation and adequate ventilation must be maintained around the pump.

When starting the pump, the good sealing of the friction plates must be visually verified. If the product leaks between the plates, the tension of the screws must be checked ([see § 6.2.2 page 22](#)). If the leak persists, take the pump apart. After a good cleaning of the different parts and a careful check of the surfaces of the friction plates and of the mechanical seal, reassemble the pump ([see § 6.2.2 page 22](#)). A perfect seal is possible only if the surfaces are dry and perfectly clean.

The pump is shipped with a liquid barrier which does not require any maintenance.

Make sure that the rotation direction of the pump is correct and inputs/outputs are connected according to the rotation direction.

4.3. Sequence, Fluid diagrams and Process cycles

Color change sequence			
Rinsing circuit phase 1			
Rinsing circuit phase 2			
Rinsing bellcup			
Filling circuit			

4.3.1. Assembly installed on the robot arm with sprayer without coil

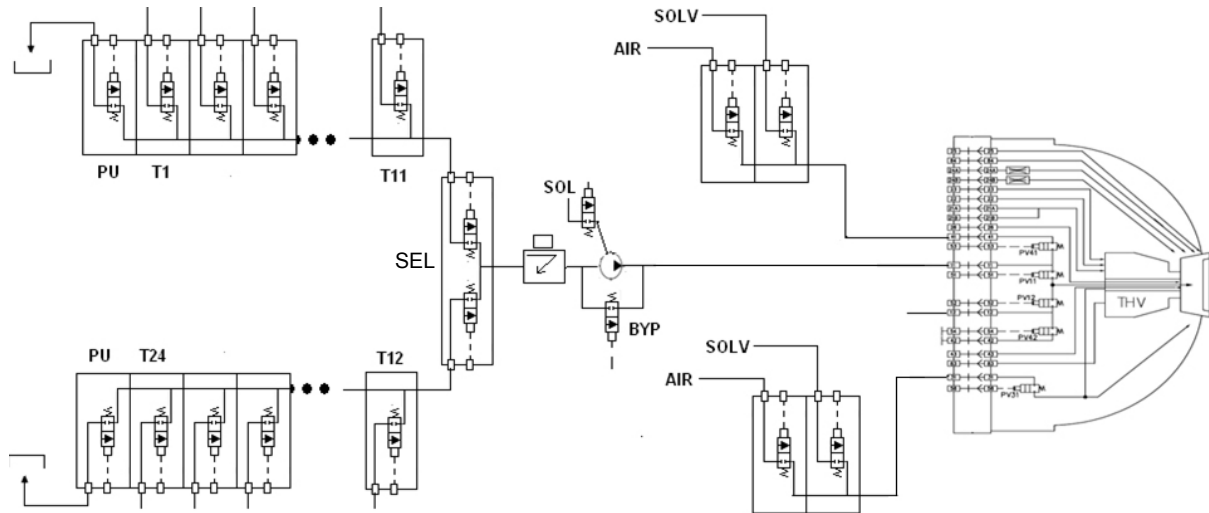

Filling circuit			
Time basis (50ms)	10	36	4
Color			
Selection valve (SEL)			
Shunt pump (BYP)			
Trigger (PV 11)			
Motor speed in rpm	0	80	0

Rinsing circuit Phase 1						
Time basis (50ms)	40	4	14	4	14	4
Air						
Solvent						
Trigger (PV11)						
Dump PPH (PV41)						
Pump solvent (SOL)						
Shunt pump (BYP)						
Selection valve (SEL)						
CCV dump (PU)						
Motor speed in rpm	50	50	50	50	50	50

Rinsing circuit Phase									
Time basis (50ms)	14	4	14	4	14	4	14	2	2
Air									
Solvent									
Trigger (PV11)									
Dump PPH (PV41)									
Pump solvent (SOL)									
Shunt pump (BYP)									
Selection valve (SEL)									
CCV dump (PU)									
Motor speed in rpm	50	50	50	50	50	50	50	0	0

Rinsing bellcup									
Time basis (50ms)	12	4	12	4	12	4	12	4	16
Air rinsing bellcup									
Solvent rinsing bellcup									
PV31									



WARNING : During the phases of rinsing, the pump always turns in the same direction (see direction of rotation indicated on the pump).

4.3.2. Assembly installed on the robot arm with sprayer with coil

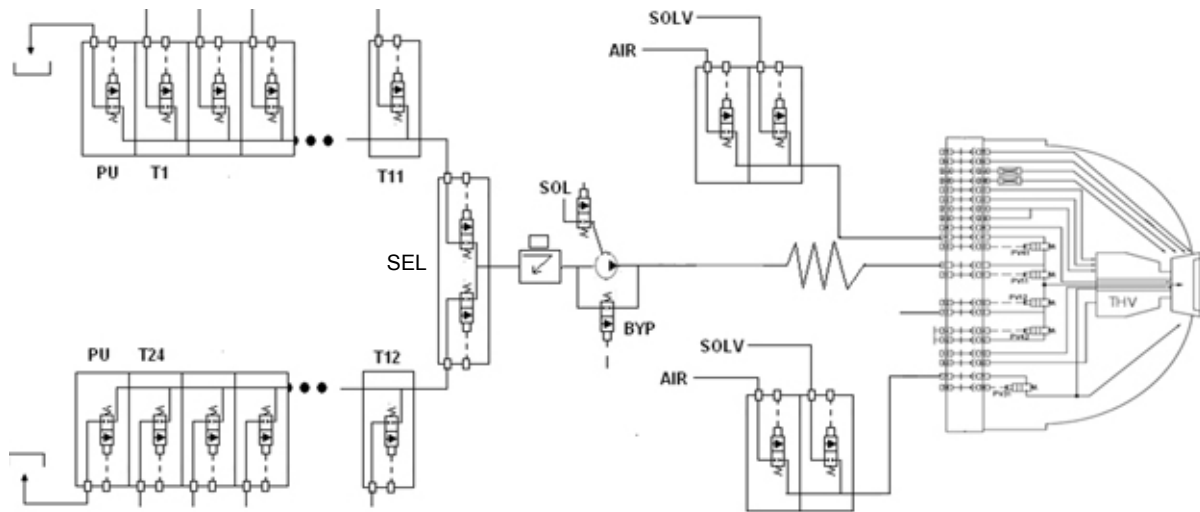

Filling circuit			
Time basis (50ms)	10	54	4
Color			
Selection valve (SEL)			
Shunt pump (BYP)			
Trigger (PV 11)			
Motor speed in rpm	0	80	0

Rinsing circuit Phase 1						
Time basis (50ms)	60	4	14	4	14	4
Air						
Solvent						
Trigger (PV11)						
Dump PPH (PV41)						
Pump solvent (SOL)						
Shunt pump (BYP)						
Selection valve (SEL)						
CCV dump (PU)						
Motor speed in rpm	50	50	50	50	50	50

Rinsing circuit Phase 2									
Time basis (50ms)	14	4	14	4	14	4	14	2	2
Air									
Solvent									
Trigger (PV11)									
Dump PPH (PV41)									
Pump solvent (SOL)									
Shunt pump (BYP)									
Selection valve (SEL)									
CCV dump (PU)									
Motor speed in rpm	50	50	50	50	50	50	50	0	0

Rinsing Bellcup									
Time basis (50ms)	12	4	12	4	12	4	12	4	16
Air rinsing bellcup									
Solvent rinsing bellcup									
PV31									



WARNING : During the phases of rinsing, the pump always turns in the same direction (see direction of rotation indicated on the pump).

5. Operating



WARNING : The metering pump is designed to run in a continuous manner, but can also be used intermittently. During relatively short off periods, no particular maintenance or repair is necessary. The bearings are lubricated by the product metered and therefore it is advised NOT to run the pump dry.

5.1. Tools

- 3/4/5mm hex socket wrench (Dynamometric 8 to 10 Nm).
- 4 mm hex socket wrench.
- Plastic mallet.
- Screwdrivers (Nr 2 and 4).
- Indelible marker.
- Cleaning paper.
- 1 sheet of paper of glass 1600.
- 1 fine abrasive stone (800 -1000).
- Solvent or hardener compatible with the product in the pump.
- 1 brush (hard) for the \varnothing 5mm grooves.
- Protective gear (according to the recommendations given by the manufacturer of the product to be metered).



Part Number	Description	Qty	Sale unit
270000122	Special tool set for sealing unit	1	1

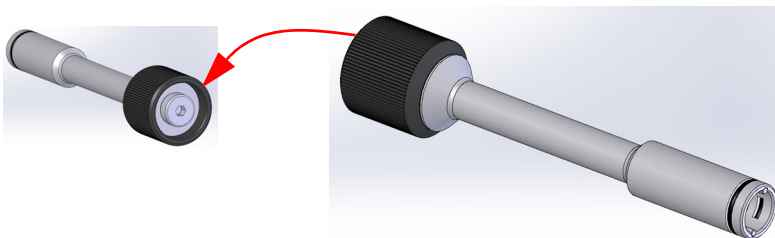

Part Number	Description	Qty	Sale unit
910013686	Torque wrench for valve	1	1

5.2. Breaking in the new pump

The pumps are broken in and ready to use.



WARNING : Rinsing a pump is a destructive operation for the pump when the recommendations are not followed to the point.

Before starting the pump for the first time, a rinsing is necessary. It must be done with the rinsing product recommended by the paint manufacturer.

Respect the direction of rotation indicated by the arrow.



WARNING : The rinsing must respect the following conditions:

- The rinsing time must be as short as possible because certain products of rinsing do not contain lubricant,
- the rotation speed must not exceed 40 rpm.

- Let the pump turn at a rotation speed of 20 to 30 rpm, with product in it, with an input pressure no to exceeding 3 bars and an outpressure of 0 bar, for one hour (if possible in close circuit).
- Following the same idea, increase the output pressure to 5 bars and so for 30 minutes.
- Then gradually, increase until the maximum pressure allowed is reached (15 bars), doing so 30 minutes at a time. During this time, it is possible to calibrate the pump in order to observe the output curb with the product running, and to compensate for any internal leakage of the pump by setting the rotation speed.

6. Maintenance

6.1. Replacement of the Upvalve on the shunt block

- Position the tool (P/N 910013686) on the Upvalve, loosen the Upvalve and remove it.



If the valve is locked, insert a 4mm Allen wrench on the back of the tool, place the assembly on the valve and loosen.



Installation of the Upvalve on a shunt block:

- Place the Upvalve on the tool. Check that the o-ring is in place on the bottom of the valve.



- Put in place the valve on the block and tighten it with the black button until it slides



WARNING : It is imperative to use the black button for the tightening because the tightening torque is integrated.



6.2. Pump

6.2.1. Disassembly Procedure



WARNING : A preventive maintenance is advised after 1600 operating hours. All the elements of the pump must be handled with an extreme delicacy, any shock between the different components could harm the future correct operation of the pump.

Step 1

Unscrew the six securing screws of the rear plate (1) and separate it by carrying out a small rotation using a screwdriver.

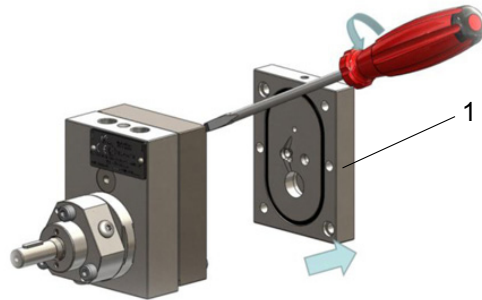

Step 2

Remove the o-ring. Clean the rear plate using an appropriate solvent, pay a particular attention to the o-ring groove. The o-ring must be replaced at each reassembly.

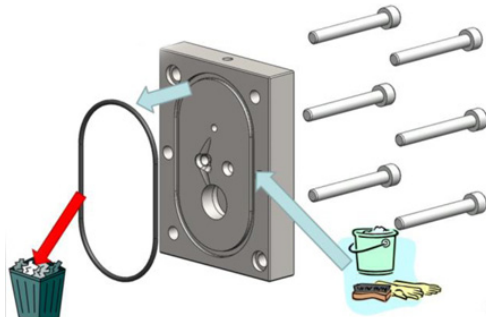

Step 3

Remove the upper part of the pump body. Remove the two centering round key (2).

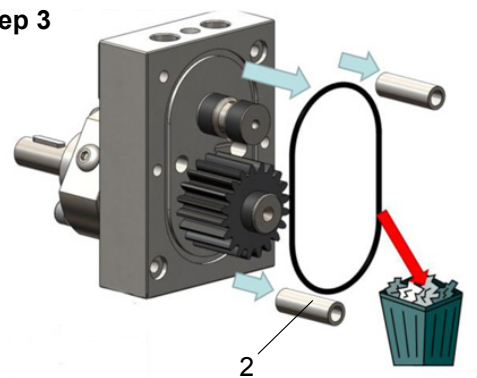

Step 4

Withdraw the key (3) from the drive shaft (4).

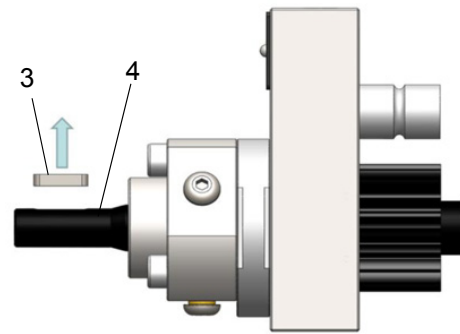

Step 5

Remove the o-ring. Clean the body (5) using an appropriate solvent, pay a particular attention to the o-ring groove. The o-ring must be replaced at each reassembly.

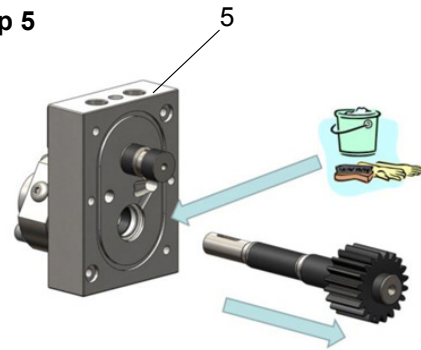

Step 6

Unscrew the three screws of the sealing unit.

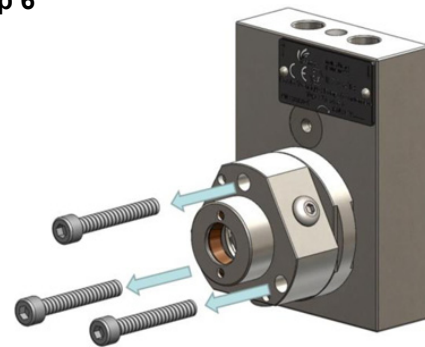

Step 7

Remove the sealing unit (6).



Step 8

Extract the lip seal (7) from the body pump. Replace at each reassembly.

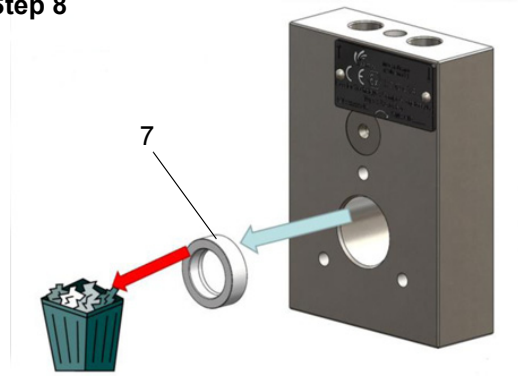

Step 9

Remove the o-ring (10) and unscrew the two M 4x 20 screws (11).

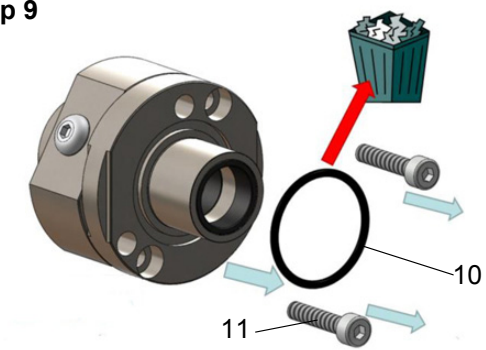

Step 10

Remove the two viton O-rings (10) and the lip seal (12). Systematically replace them.

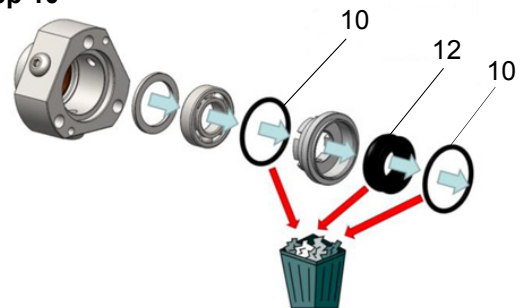

Step 11

Using a pin-drift, extract the lip seal (13) from the sealing unit.

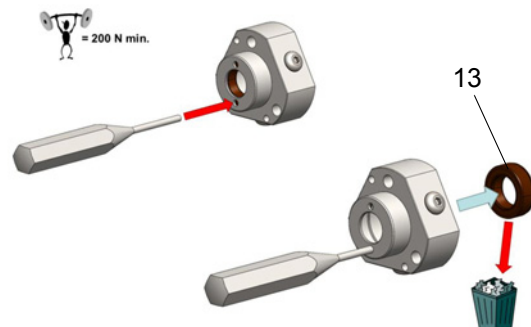

Step 12

Unscrew the M5 x 6 screws.

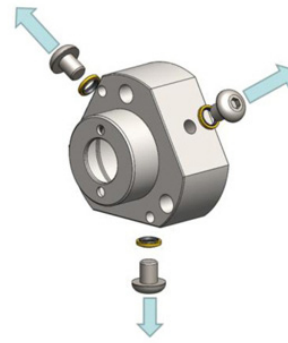

WARNING : Disassembling may be assisted by tapping with a plastic mallet or by the introduction of blades made from synthetic material (nylon).
Use of materials that are harder than the pump material may result in permanent damage to the components.

6.2.2. Reassembly Procedure

Put in place the tool on the sealing unit cover (14).

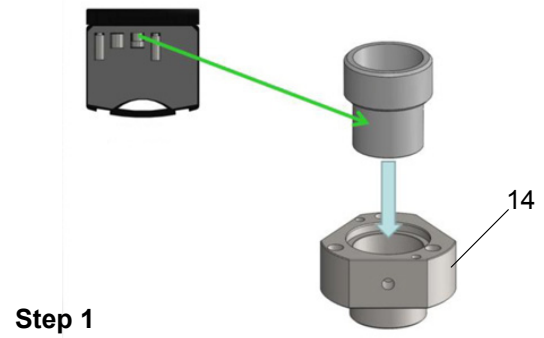

Install the lip seal (13) on the tool.

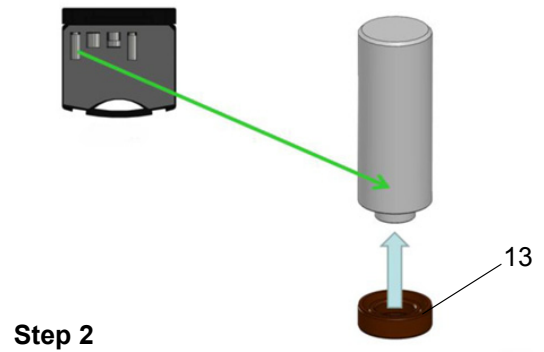

Place the lip seal on the sealing unit cover.

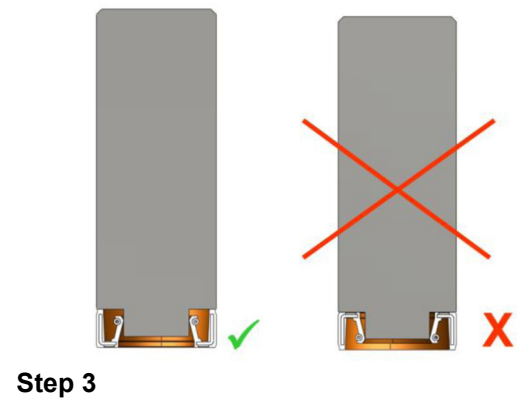

WARNING : Note the direction of the lip seal.

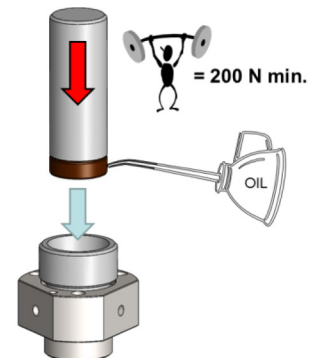

Remove the tools.

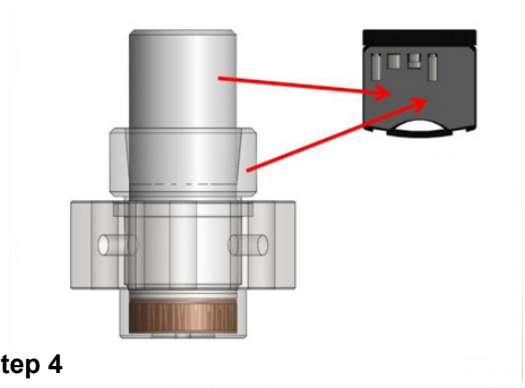

Place the tool on the seal holder (15).

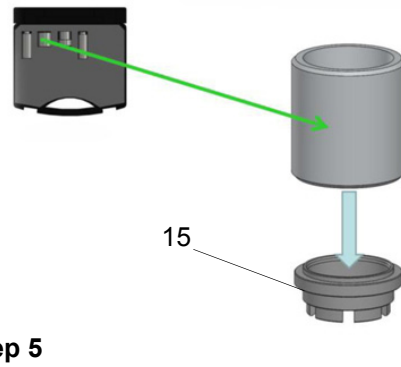

Place the tool on the lip seal (12).

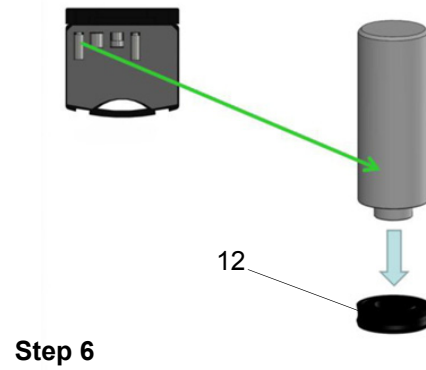

Place the lip seal (12) on the seal holder (15).



WARNING : Note the direction of the lip seal.

Then remove the tools.

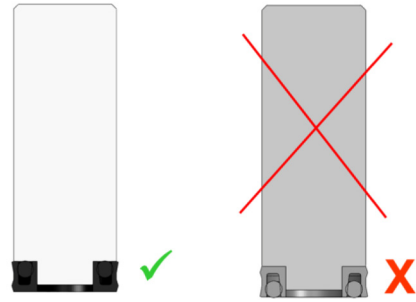

Step 7

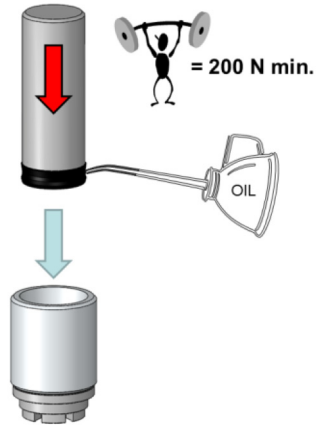

Step 8

Replace imperatively the seals then put back in place in the sealing unit cover.

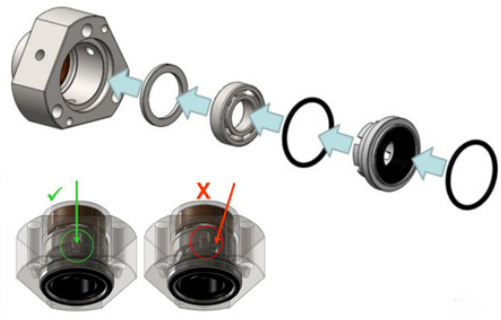

Step 9

Screw the sealing unit body on the cover.

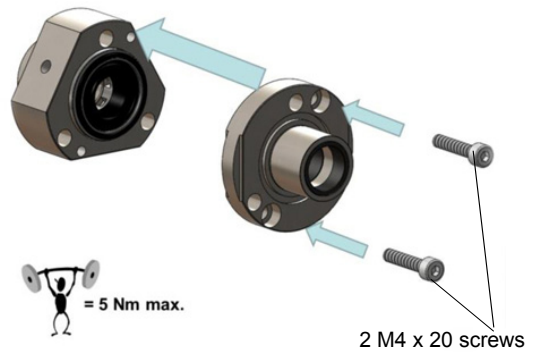

Step 10

Place a new O-ring on the sealing unit.

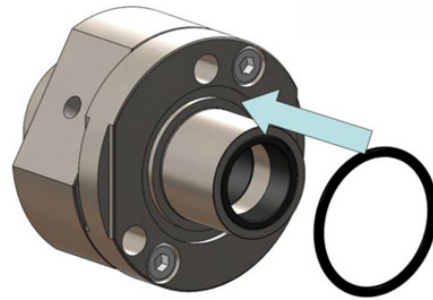

Install a new lip seal (7) on the tool.

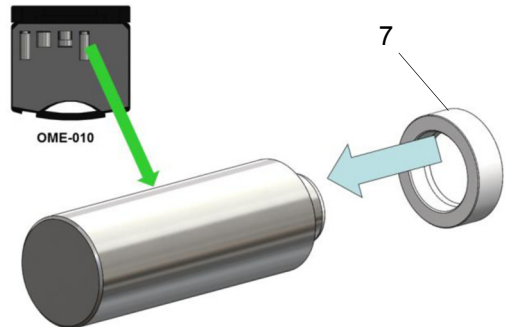

Step 11



WARNING : Note the direction of the lip seal.

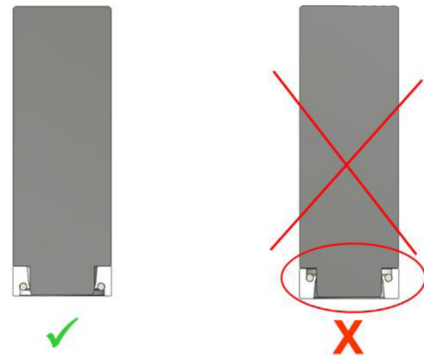

Put in place the lip seal (7) in the pump body.

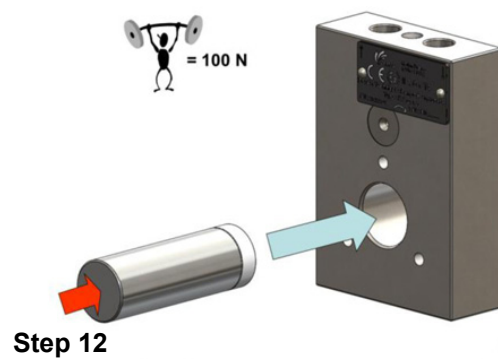

Step 12

Step 13

Screw the sealing unit on the pump body (tightening torque: 10N.m).

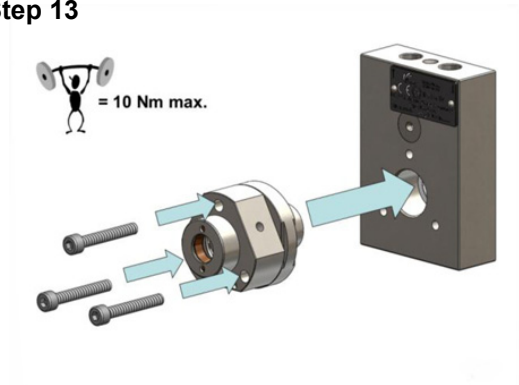

Step 14

Insert the drive shaft in the body pump.

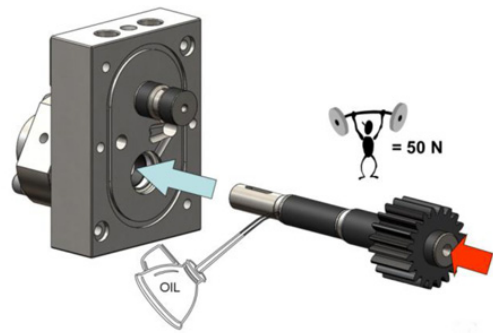

Step 15

Install a new O-ring on the pump body.

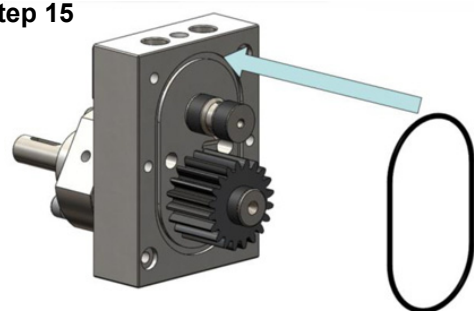

Step 16

Install the centering pins on the pump body then place the upper plate.

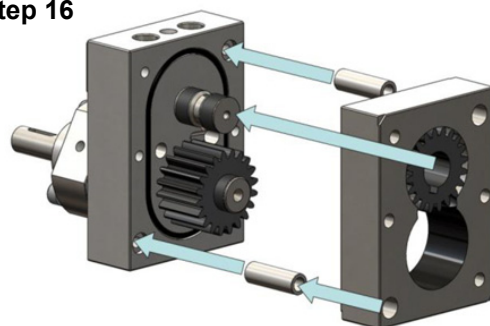

Step 17

Place a new o-ring on the rear plate.

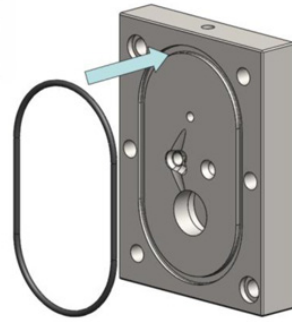

Step 18

Install the rear plate and secure it with the six screws (tightening torque: 10N.m).

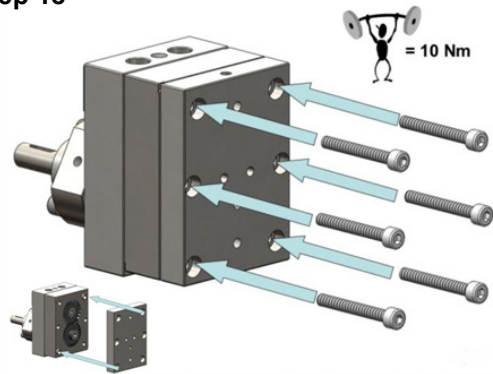

Step 19

Put in place screws and washers, screw with a tightening torque 5 N.m.

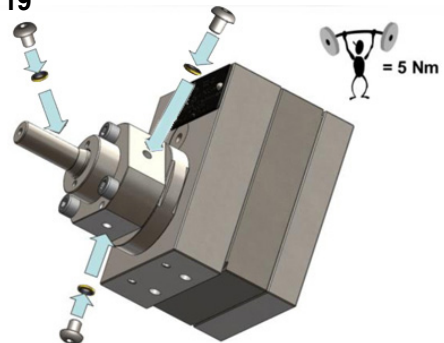

Step 20

Insert the key into the drive shaft.

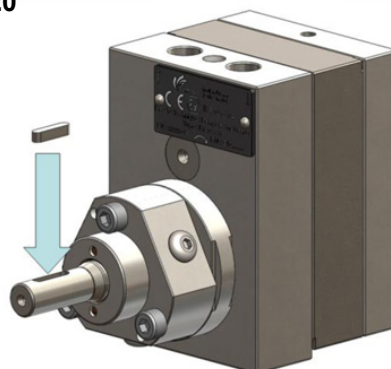

7. Cleaning



WARNING : The elements will be dipped in the solvent appropriate for the product metered. Using a nylon brush or flexible scraper, remove the traces of paint and seals remaining on the components. Dry with compressed air.

The element must never hit anything or be hit anything during this procedure. The parts will be put in the container with care.

For the cleaning operation, do not use metallic tools as screwdrivers, knives or chisels.

In order not to mix the parts from different pumps, only one pump will be cleaned in one container at a time.

The cleaning of a pump is often tedious.

This procedure is however, of prime importance in order to correctly analyse signs of wear and tear and to ensure perfect assembly, which in turn, ensures successful functioning of the pump.

8. Troubleshooting

Symptoms	Probable Causes	Remedies
Product leaking in the drive Shaft seal	Driving shaft worn Sealing unit worn out Incompatible products or pressures	Remove and check. Replace if necessary Contact Sames Technologies
Leakage in the plates area	Impurities between the plates Allowed pressures exceeded. Very thin liquid (leak by capillarity)	Take apart and clean the pump. Check the screw and tighten if necessary. Lower the pressures. Contact Sames Technologies
No precision in the metering.	Pump elements are worn out. Impurities in the Input/Output hoses. Feeding pressure too weak. Play not adapted to the product. Error during assembly	Take apart and check the pump elements as well as the I/O hoses. Check the I/O pressures. Check the viscosity of the product.
No output (the pump does not run)	The motor does not run. The coupling is broken or missing.	Check the motor and its electrical connection. Check the coupling and the keys.
No output (the pump runs)	The I/O are poorly connected or plugged. The pin driving the gears is broken. No product enters the pump.	Check the I/O connections. Check the feeding of the pump. Take apart the pump and check the pin and the gears.

9. Spare parts

9.1. FCG equipped pumps

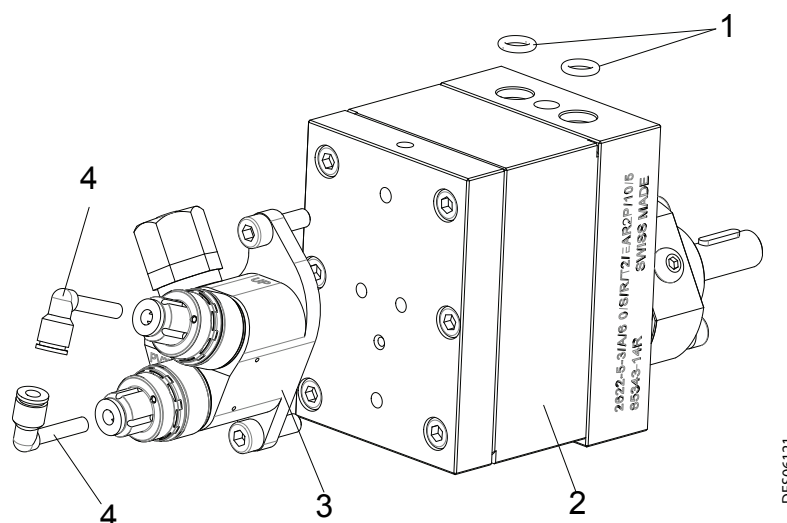

Item	Part number	Description	Qty	Unit of sale	Maintenance level for spare parts (*)
	910020408	FCG equipped pump - 10 cc	1	1	3
1	J3STKL011	O-ring chemically inert	2	1	1
2	270000114	FCG Pump - 10 cc	1	1	3
3	910017471	Shunt block (see § 9.1.1 page 31)	1	1	3
4	F6RLDS147	Quick release elbow union	2	1	2

Item	Part number	Description	Qty	Unit of sale	Maintenance level for spare parts (*)
	910020407	FCG equipped pump - 6 cc	1	1	3
1	J3STKL011	O-ring chemically inert	2	1	1
2	270000115	FCG Pump - 6 cc	1	1	3
3	910017471	Shunt block (see § 9.1.1 page 31)	1	1	3
4	F6RLDS147	Quick release elbow union	2	1	2

Item	Part number	Description	Qty	Unit of sale	Maintenance level for spare parts (*)
	910020406	FCG equipped pump - 3 cc	1	1	3
1	J3STKL011	O-ring chemically inert	2	1	1
2	270000116	FCG Pump - 3 cc	1	1	3
3	910017471	Shunt block (see § 9.1.1 page 31)	1	1	3
4	F6RLDS147	Quick release elbow union	2	1	2

(*) Level 1: Standard preventive maintenance

Level 2: Corrective maintenance

Level 3: Exceptional maintenance

9.1.1. Shunt block

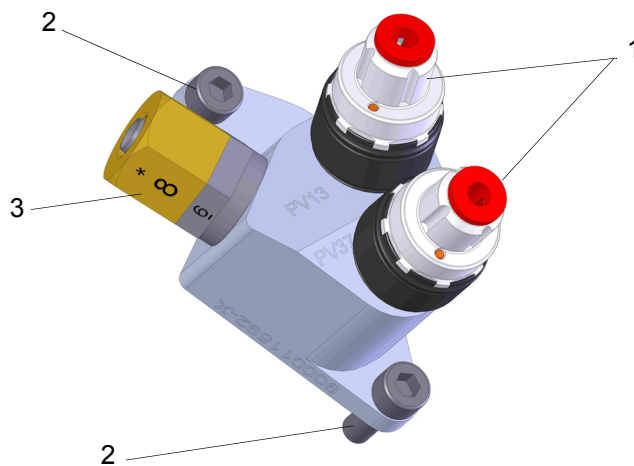

Item	Part number	Description	Qty	Unit of sale	Maintenance level for spare parts (*)
	910017471	Shunt block	1	1	3
1	910012239S	UPvalve, pilot valve (see § 9.1.1.1 page 32)	2	1	1
2	X4FVSY184	Stainless steel Chc M5 x 16 screw	2	1	3
3	910007348	Fitting 6/ 8 - G 1/4	1	1	3

(*)

Level 1: Standard preventive maintenance

Level 2: Corrective maintenance

Level 3: Exceptional maintenance

9.1.1.1. Upvalve

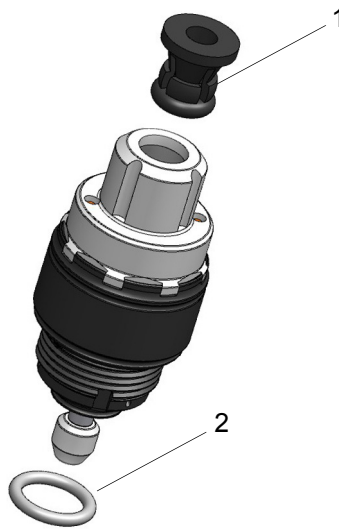

Item	Part number	Description	Qty	Unit of sale	Maintenance level for spare parts (*)
	910012239S	UPvalve, pilot valve	1	1	1
1	F6RXZG081	Stainless steel grip + o-ring	1	1	3
2	J3STKL102	O-ring - chemically inert	1	1	1

(*)

Level 1: Standard preventive maintenance

Level 2: Corrective maintenance

Level 3: Exceptional maintenance

9.2. FCG Pumps

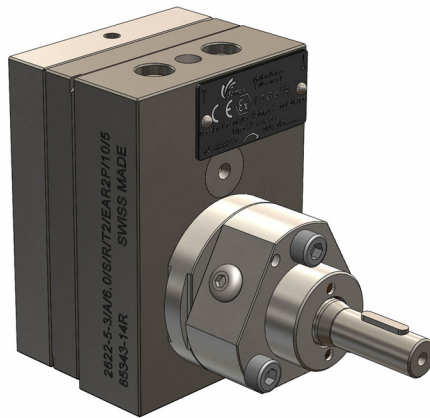

Item	Part number	Description	Qty	Unit of sale	Maintenance level for spare parts (*)
	270000114	FCG Pump - 10 cc	1	1	3
	270000115	FCG Pump - 6 cc	1	1	3
	270000116	FCG Pump - 3 cc	1	1	3

(*)

Level 1: Standard preventive maintenance

Level 2: Corrective maintenance

Level 3: Exceptional maintenance

9.3. Maintenance kits for FCG pumps

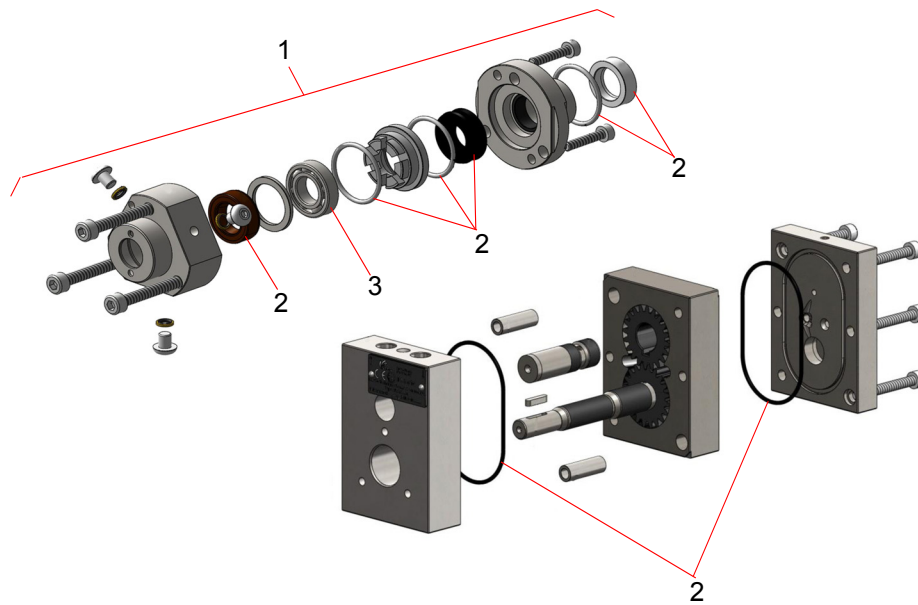

Item	Part number	Description	Qty	Unit of sale	Maintenance level for spare parts (*)
1	270000123	Complete sealing unit	1	1	2
2	270000124	Seal kit for sealing system + pump included	1	1	1
		O-ring - viton 56.87 x 1.78	2	-	-
		O-ring 23.52 x 1.78	3	-	-
		Lip seal, PTFE	1	-	-
		Dual lip seal, PE-UHMW	1	-	-
		Lip seal, viton	1	-	-
3	270000092	Ball bearing	1	1	2

(*)

Level 1: Standard preventive maintenance

Level 2: Corrective maintenance

Level 3: Exceptional maintenance

9.4. Connecting Flanges

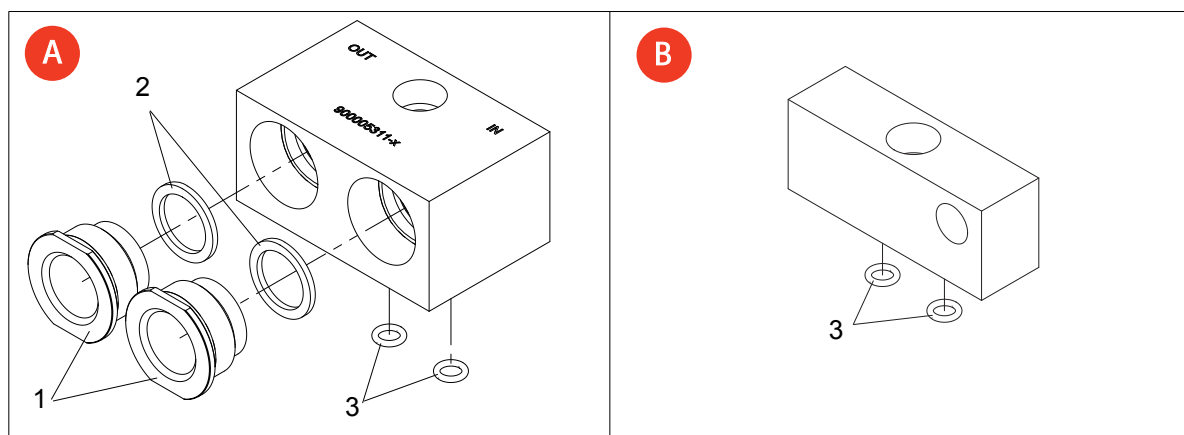

DES06106

Item	Part number	Description	Qty	Unit of sale	Maintenance level for spare parts (*)
A	910007409	2 Pressure switch flange	Option	1	-
1	270000023	Tightening adapter	2	1	-
2	270000024	O-ring - PTFE	2	1	1
3	J3TTCN118	O-ring - white PTFE	2	1	1
B	910008031	Fitting fixing flange	Option	1	-
3	J3TTCN118	O-ring - white PTFE	2	1	1



WARNING : If flanges are used, replace the 2 o-rings (P/N # J3STKL011) located on the pump by the 2 o-rings (P/N # J3TTCN018 , item 3).

Remarks: Flanges are used to connect, according to the type, one or two pressure switches.

Part number	Description	Qty	Unit of sale	Maintenance level for spare parts (*)
220000068AT	Pressure switch (0 to 50 bar) (pump outlet)	-	1	3
220000069AT	Pressure switch (0 to 16 bar) (pump inlet)	-	1	3
900005312	Pressure switch plug	-	1	3

(*) **Level 1: Standard preventive maintenance**

Level 2: Corrective maintenance

Level 3: Exceptional maintenance

Remarks: Connecting flanges are fitted to the pumps by a Chc M8x 40 screw (P/N X3AVSY287).

Remarks:

- 1 When a pressure switch is used, it is imperative beforehand to install a tightening adapter (P/N: 270000023) on the connecting flange.
- 2 Put in place the o-ring (P/N: 270000024) then the plug (P/N: 900005312), when a pressure switch exit is not used.