



DOCUMENTATION - DOKUMENTATION - DOCUMENTACIÓN

POMPE / PUMP / PUMPE / BOMBA

04-120 F

FLOWMAX[®]

Notice / Manual / Betriebsanleitung / Libro : 582.042.110 - 1605

Date / Datum / Fecha : 27/05/16

Annule / Supersede / Ersetzt / Anula :

Modif. / Änderung :

NOTICE ORIGINALE / TRANSLATION FROM THE ORIGINAL MANUAL
/ ÜBERSETZUNG DER ORIGINAL BETRIEBSANLEITUNG
/ TRADUCCIÓN DEL MANUAL ORIGINAL

IMPORTANT : Lire attentivement tous les documents avant le stockage, l'installation ou la mise en service du matériel concerné (à usage strictement professionnel).

Before assembly and start-up, please read and clearly understand all the documents relating to this equipment (professional use only).

WICHTIGER HINWEIS: Vor Lagerung, Installation oder Inbetriebnahme des Geräts bitte sämtliche Dokumente sorgfältig lesen (Einsatz nur von geschultem Personal).

IMPORTANTE : Lea con atención todos los documentos antes de almacenar, instalar o poner en marcha el equipo (uso exclusivamente profesional).

PHOTOS ET ILLUSTRATIONS NON CONTRACTUELLES. MATERIELS SUJETS A MODIFICATION(S) SANS PREAVIS.

THE PICTURES AND DRAWINGS ARE NON CONTRACTUAL. WE RESERVE THE RIGHT TO MAKE CHANGES WITHOUT PRIOR NOTICE.

ALLE IN DIESEM DOKUMENT ENTHALTENEN SCHRIFTLICHEN ANGABEN UND ABBILDUNGEN STELLEN DIE NEUESTEN

PRODUKTINFORMATIONEN DAR. WIR BEHALTEN UNS DAS RECHT VOR, JEDERZEIT OHNE VORANKÜNDIGUNG ÄNDERUNGEN VORZUNEHMEN.

LAS FOTOGRAFÍAS E ILUSTRACIONES NO SON VINCULANTES. LOS MATERIALES ESTÁN SUJETOS A CAMBIOS SIN PREVIO AVISO.

KREMLIN - REXSON

150, avenue de Stalingrad

93 245 - STAINS CEDEX - France

☎ : 33 (0)1 49 40 25 25 Fax : 33 (0)1 48 26 07 16

www.kremlin-rexson.com



INSTALLATION AND SAFETY INSTRUCTIONS

TRANSLATION OF THE ORIGINAL MANUAL

IMPORTANT : Before assembly and start-up, please read and clearly understand all the documents relating to this equipment (professional use only).

THE PICTURES AND DRAWINGS ARE NON CONTRACTUAL. WE RESERVE THE RIGHT TO MAKE CHANGES WITHOUT PRIOR NOTICE.

KREMLIN - REXSON

150, avenue de Stalingrad

93 245 - STAINS CEDEX – France

☎ : 33 (0)1 49 40 25 25 *Fax* : 33 (0)1 48 26 07 16

www.kremlin-rexson.com

1. SAFETY INSTRUCTIONS

GENERAL SAFETY INSTRUCTIONS



CAUTION : The equipment can be dangerous if you do not follow our instructions concerning installation and servicing described in this manual and in accordance with applicable European standards and local national safety regulations.

Please carefully read all the instruction literature before operating your equipment.

Only trained operators can use the equipment (To acquire an essential training, please contact the "KREMLIN REXSON University" training center - Stains).

The foreman must ensure that the operator has understood the safety instructions for this equipment as well as the instructions in the manuals for the different parts and accessories.

Read carefully all instruction manuals, label markings before operating the equipment.



















Incorrect use may result in injury. This equipment is for professional use only. It must be used only for what it has been designed for. Never modify the equipment. The parts and accessories supplied must be regularly inspected. Defective or worn parts must be replaced.

Guards (motor cover, coupling shields, connectors,...) have been designed for a safe use of the equipment.
The manufacturer will not be held responsible for bodily injury or failure and / or property damage due to destruction, the overshadowing or the partial or total removal of the guards.

Never exceed the equipment components' maximum working pressure.

Comply with regulations concerning safety, fire risks, electrical regulations in force in the country of final destination of the material. Use only products or solvent compatible with the parts in contact with the material (refer to data sheet of the material manufacturer).

PICTOGRAMS

					
NIP HAZARD	WARNING MOVING ELEVATOR	WARNING MOVING PARTS	WARNING MOVING SHOVEL	DO NOT EXCEED THIS PRESSURE	HIGH PRESSURE HAZARD
					
RELIEF OR DRAIN VALVE	WARNING HOSE UNDER PRESSURE	WEAR GLASSES OBLIGATORY	WEAR OF GLOVES IS OBLIGATORY	PRODUCT VAPOR HAZARDS	WARNING HOT PARTS OR AREAS
					
ELECTRICAL HAZARD	WARNING FIRE HAZARDS	EXPLOSION HAZARDS	GROUNDING	WARNING (USER)	WARNING SERIOUS INJURIES

FIRE - EXPLOSION - SPARKS - STATIC ELECTRICITY HAZARDS

A poor earth connection, inadequate ventilation, sparks or static electricity can cause an explosion or fire. to avoid these risks when using or servicing KREMLIN REXSON equipment, the following safety procedures must be followed :



- ensure a good earth connection and ground the parts to be handled i.e. solvents, materials, components and equipment,
- ensure adequate ventilation,
- keep working area clean and free from waste solvents, chemicals, or solid waste i.e. rags, paper and empty chemicals drums,
- never use electrical switches / power if in an atmosphere of volatile solvent vapour,
- stop working immediately in case of electrical arcs,
- never store chemicals and solvents in the working area.
- use paint whose flash point is the highest possible to prevent from any formation of gas and inflammable vapours (refer to materials' safety instructions),
- install a cover on the drums to reduce the diffusion of gas and vapours in the spraybooth.

TOXIC PRODUCT HAZARDS

Toxic products or vapours can cause severe injury not only through contact with the body, but also if the products are ingested or inhaled. It is imperative :



- to know the material products and their risks,
- notified or hazardous materials must be stored in accordance with the regulations,
- the material must be stored in an appropriate container, never place materials in a container where there is a risk of spillage or leakage,
- a procedure must be applied for the safe disposal of waste material. It must comply with all prevailing regulations and legislations of the country where the equipment is to be used,
- protective clothing should always be worn in compliance with the material manufacturers' recommendations,
- depending on the application and chemical safety instructions, safety glasses, hearing protective earplug, gloves, foot wear, protective masks and possible breathing equipment should be worn to comply with the regulations (Refer to chapter "Safety equipment of KREMLIN selection guide).



CAUTION!



It is forbidden to use material containing high concentrations of halogenated hydrocarbon solvents with **aluminium or zinc fillers** .Non-compliance with the instructions may cause explosion risk causing serious or fatal injury.

EQUIPMENT REQUIREMENTS

Guards (motor cover, coupling shields, connectors,...) have been designed for a safe use of the equipment.

The manufacturer will not be held responsible for bodily injury or failure and / or property damage due to destruction, the overshadowing or the partial or total removal of the guards.

PUMP



Before carrying out any work, it is imperative to read and clearly understand the disassembly and reassembly instructions before servicing. The operator must understand the equipment and the safety instructions. These instructions are available in the equipment manuals.



The air motor is designed to be mounted with a pump. Never modify any components or couplings. When operating, please keep hands away from moving parts. Before starting up the equipment, please read the PRESSURE RELIEF instructions. Please ensure that any relief or drain valves fitted are in good working order.

HOSES

- Keep hoses out of circulation areas, moving parts or hot surfaces,
- Never expose product hoses to temperature higher than + 60°C / 140° F or lower than 0°C / 32° F,
- Never pull or use the hoses to move the equipment,
- Tighten all fittings as well as the hoses before operating the equipment,
- Check the hoses regularly; change them if they are damaged,
- Never exceed the working pressure (WP) indicated on the hose.

USED PRODUCTS

Considering the wide variety of products that are available and can be used in our equipment it is impossible to check and make recommendations for all chemical data, regarding the risks of possible chemical attack and their long term chemical reaction

KREMLIN REXSON can not be held liable for :

- Compatibility of wetted parts,
- Risks to staff and the surroundings,
- for worn or defective parts, for faulty equipment or units, or the quality of final product.

It is the responsibility of the user to know and prevent any possible risks such as toxic vapours, fires or explosions. He shall determine the risks of immediate reactions or pursuant to repeated exposures of the staff,

KREMLIN REXSON shall not be liable for physical injuries, direct or indirect material damages caused by the use of chemicals.

2. HANDLING



Check the weight and the dimensions of the equipment

(☞ refer to 'Technical features' section of the instruction manual

If weight and dimensions are too important, the unloading must be carried out by means of a forklift or any other appropriate means with a qualified personnel and in a clear horizontal area to prevent from risks of damage injury or an accident.

The centre of gravity is not in the centre of the machine : carry out by hand a stability-test after having lifted the whole at 10 cm / 3.937" maximum.

After the unloading, the handling of the whole (eg: elevator pump) is carried out by means of a pallet truck taking the bottom part of the frame.

Remark : Each pump motor is fitted with a ring. The ring is designed for the hoisting of one pump and can not be used for the handling of the complete machine.

3. STORING

Storing before installation :

- Storing ambient temperature : 0 / +50 °C / 0 / +122°F
- Protect the whole against dust, water trickling, dampness and shocks.

Storing after installation :

- Operating temperature : +15 / +35 °C / +59 / +138.2° F
- Protect the whole against dust, water trickling, dampness and shocks.

4. INSTALLATION OF THE EQUIPMENT

The machine is installed on a stable horizontal floor (for eg a concrete flag).



To avoid risks caused by static electricity, the equipment as well as its components must be grounded.

- **For the pumping equipments** (pumps, pneumatic rams, frame...), a section wire of 2.5 mm² is fixed on the material. Use this wire to connect the material to "the general ground". In case of severe environments (mechanical protection of the wire of earthing insufficient, vibrations, mobile material...) where function damages at the ground are probable, the user have to replace the provided wire of 2.5 mm² by a device more adapted to its environment (wire with a more important section, bonding strip, fixing by thimble with eyelet...),

The continuity of the ground must be controlled by a qualified electrician. If the continuity of the ground is not ensured, check the terminal, the wire and the earthing point. **Never** use the material without have solved this problem.

- In the severe cases of environments (mechanical protection of the wire of earthing insufficient, vibrations, mobile material...) where damages of the function put at the ground are probable, the user will have to replace the wire of 2.5 mm² provided, by a device more adapted to its environment (wire of more important section, bonding strip, fixing by thimble with eyelet...),
- **The gun** must be 'grounded' via a material hose or an air hose. In case of spraying by means of a gun with cup, the air hose must be conductive,
- **The materials to be painted** must also be grounded.

All the materials situated in the working area shall be grounded.



- **Never store** more than necessary inflammable materials inside the working area,
- The materials must be stored into **approved drums** and grounded,
- Use only grounded **metals containers** for the use of cleaning solvents,
- **Cardboard and paper are prohibited.**

5. MARKING OF THE EQUIPMENT

Each equipment has a marking plate.

The plate consists of the name of the manufacturer, the equipment part number and important information for correct use of the equipment (air pressure, electric power,...).



<p align="center">FR</p> <p>Pour une utilisation sûre, il est de votre responsabilité de :</p> <ul style="list-style-type: none"> • Lire attentivement tous les documents contenus dans le CD joint avant la mise en service de l'équipement, • D'installer, d'utiliser, d'entretenir et de réparer l'équipement conformément aux préconisations de KREMLIN REXSON ainsi qu'aux réglementations nationales et/ou locales, • Vous assurez que les utilisateurs de cet équipement ont été formés, ont parfaitement compris les règles de sécurité et qu'ils les appliquent. 	<p align="center">UK</p> <p>To ensure safe use of the machinery, it is your responsibility to:</p> <ul style="list-style-type: none"> • Carefully read all documents contained on the enclosed CD before putting the machinery into service, • Install, use, maintain and repair the machinery in accordance with KREMLIN REXSON's recommendations and national and/or local regulations, • Make sure that the users of the machinery have received proper training and that they have perfectly understood the safety rules and apply them. 	<p align="center">DE</p> <p>Eine sichere Nutzung setzt voraus, dass Sie: :</p> <ul style="list-style-type: none"> • alle in der CD enthaltenen Dokumente vor der Inbetriebnahme der Anlage aufmerksam lesen, • die Anlage im Einklang mit den Empfehlungen von KREMLIN REXSON sowie mit den nationalen und/oder lokalen Bestimmungen installieren, verwenden, warten und reparieren, • sich vergewissern, dass die Nutzer dieser Anlage angemessen geschult wurden, die Sicherheitsbestimmungen verstanden haben und sie anwenden.
<p align="center">ES</p> <p>Para una utilización segura, será de su responsabilidad:</p> <ul style="list-style-type: none"> • leer atentamente todos los documentos que se incluyen en el CD adjunto antes de la puesta en servicio del equipo, • instalar, utilizar, efectuar el mantenimiento y reparar el equipo con arreglo a las recomendaciones de KREMLIN REXSON y a la normativa nacional y/o local, • cerciorarse de que los usuarios de este equipo han recibido la formación necesaria, han entendido perfectamente las normas de seguridad y las aplican. 	<p align="center">IT</p> <p>Per un uso sicuro, vi invitiamo a:</p> <ul style="list-style-type: none"> • leggere attentamente tutta la documentazione contenuta nel CD allegato prima della messa in funzione dell'apparecchio, • installare, utilizzare, mantenere e riparare l'apparecchio rispettando le raccomandazioni di KREMLIN REXSON, nonché le normative nazionali e/o locali, • accertarvi che gli utilizzatori dell'apparecchio abbiano ricevuto adeguata formazione, abbiano perfettamente compreso le regole di sicurezza e le applichino. 	<p align="center">PT</p> <p>Para uma utilização segura, é da sua responsabilidade:</p> <ul style="list-style-type: none"> • Ler atentamente todos os documentos incluídos no CD em anexo antes de pôr o equipamento em funcionamento, • Proceder à instalação, utilização, manutenção e reparação do equipamento de acordo com as preconizações de KREMLIN REXSON, bem como com outros regulamentos nacionais e/ou locais aplicáveis, • Assegurar-se que os utilizadores do equipamento foram devidamente capacitados, compreenderam perfeitamente e aplicam as devidas regras de segurança.
<p align="center">NL</p> <p>Voor een veilig gebruik dient u:</p> <ul style="list-style-type: none"> • alle document op de bijgevoegde cd aandachtig te lezen alvorens het apparaat in werking te stellen, • het apparaat te installeren, gebruiken, onderhouden en repareren volgens de door KREMLIN REXSON gegeven aanbevelingen en overeenkomstig de nationale en/of plaatselijke reglementeringen, • zeker te stellen dat de gebruikers van dit apparaat zijn opgeleid, de veiligheidsregels perfect hebben begrepen en dat zij die ook toepassen. 	<p align="center">SE</p> <p>För en säker användning av utrustningen ansvarar ni för följande:</p> <ul style="list-style-type: none"> • Läs noga samtliga dokument som finns på den medföljande cd-skivan innan utrustningen tas i drift. • Installera, använd, underhåll och reparera utrustningen enligt anvisningarna från KREMLIN REXSON och enligt nationella och/eller lokala bestämmelser. • Försäkra er om att användare av denna utrustning erhållit utbildning, till fullo förstått säkerhetsföreskrifterna och tillämpar dem. 	<p align="center">FI</p> <p>Käytön turvallisuuden varmistamiseksi velvollisuutesi on:</p> <ul style="list-style-type: none"> • Lukea huolella kaikki CD:llä olevat asiakirjat ennen laitteiston käyttöönottoa, • Noudattaa laitteiston asennuksessa, käytössä, kunnossapidossa ja huollossa KREMLIN REXSON in suosituksia sekä kansallisia ja/tai paikallisia määräyksiä, • Varmistaa, että laitteiston käyttäjät ovat koulutettuja ja ymmärtävät täysin turvallisuusmääräykset ja miten niitä sovelletaan.
<p align="center">PL</p> <p>Dla zapewnienia bezpiecznego użytkowania na użytkownika spoczywa obowiązek:</p> <ul style="list-style-type: none"> • Uważnego zapoznania się ze wszystkimi dokumentami znajdującymi się na załączonej płycie CD przed pierwszym uruchomieniem urządzenia, • Instalowania, użytkowania, konserwacji i naprawy urządzenia zgodnie z zaleceniami firmy KREMLIN REXSON oraz z przepisami miejscowymi, • Upewnienia, że wszyscy przeszkoleni użytkownicy urządzenia zrozumieli zasady bezpieczeństwa i stosują się do nich. 	<p align="center">CS</p> <p>Pro bezpečné používání jste povinni:</p> <ul style="list-style-type: none"> • Před uvedením zařízení do provozu si pozorně přečíst veškeré dokumenty obsažené na příloženém CD, • Nainstalovat, používat, udržovat a opravovat zařízení v souladu s pokyny firmy KREMLIN REXSON a s národními a/nebo místními legislativními předpisy, • Ujistit se, že uživatelé tohoto zařízení byli vyškoleni, že dokonale pochopili bezpečnostní pravidla a že je dodržují. 	<p align="center">RU</p> <p>Для целей безопасного использования необходимо:</p> <ul style="list-style-type: none"> • Ознакомиться со всеми документами, содержащимися в прилагаемом компакт-диске до ввода оборудования в эксплуатацию; • Устанавливать, использовать, производить техническое обслуживание и ремонт оборудования в соответствии с рекомендациями KREMLIN REXSON и национальным и/или местным законодательством; • Убедиться, что пользователи настоящего оборудования прошли подготовку, надлежащим образом усвоили правила безопасности и обеспечивают их соблюдение.

Déclaration(s) de conformité au verso de ce document / Declaration(s) of conformity at the back of this document / Konformitätserklärung(en) auf der Rückseite dieser Unterlage / Declaración (es) de conformidad en el reverso de este documento / Dichiarazione/i di conformità sul retro del presente documento / Declaração(ões) de conformidade no verso do documento / Conformiteitsverklaring(en) op de keerzijde van dit document / Försäkran om överensstämmelse på omstående sida av detta dokument / Vaatimustenmukaisuusvakuutukset tämän asiakirjan kääntöpuolella / Deklaracja(e) zgodności na odwrocie dokumentu / Prohlášení o shodě se nachází/nacházejí na zadní straně tohoto dokumentu / Сертификат(ы) соответствия расположены на оборотной стороне настоящего документа

VALABLE JUSQU'AU 19 AVRIL 2016
 VALID UNTIL 19 APRIL 2016
 GÜLTIG BIS ZUM 19. APRIL 2016
 VALIDEZ HASTA EL 19 DE ABRIL DE 2016
 VALIDO FINO AL 19 APRILE 2016
 APLICÁVEL ATÉ 19 DE ABRIL DE 2016
 GELDIG TOT 19 APRIL 2016
 GÄLLER TILL OCH MED DEN 19 APRIL 2016
 VOIMASSA 19.4.2016 SAAKKA
 WAŻNOŚĆ DO 19 KWIETNIA 2016 R.
 PLATÍ DO 19. DUBNA 2016
 ДЕЙСТВИТЕЛЬНО ДО 19 АПРЕЛЯ 2016 ГОДА



DECLARATION CE DE CONFORMITE
EC DECLARATION OF CONFORMITY
EG KONFORMITÄTSEKTLÄRUNG
DECLARACIÓN CE DE CONFORMIDAD
DICHIARAZIONE CE DI CONFORMITÀ
DECLARAÇÃO CE DE CONFORMIDADE
EG-VERKLARING VAN OVEREENSTEMMING
EG-FÖRSÄKRAN OM ÖVERENSSTÄMMELSE
EY-VAATIMUKSEN MUKAISUUSVAKUUTUS
DEKLARACJA ZGODNOŚCI CE
CE PROHLÁŠENÍ O SHODĚ
ДЕКЛАРАЦИЯ СООТВЕТСТВИЯ CE

Le fabricant / The manufacturer / Der Hersteller / El fabricante / Il produttore / O fabricante / De fabrikant / Tillverkare / Valmistaja / Producent / Výrobce / Изготовитель:	KREMLIN REXSON 150, avenue de Stalingrad 93 240 - STAINS - FRANCE Tél. 33 (0)1 49 40 25 25 - Fax : 33 (0)1 48 26 07 16
--	--

Déclare que le matériel désigné ci-après / Herewith declares that the equipment / erklärt hiermit, dass die / Declara que el material designado a continuación / Dichiaro che il materiale sottoindicato / Declara que o material a seguir designado / verklaart dat de hieronder aangeduide apparatuur / Kungör att den utrustning som anges här nedan / ilmoittaa, että alla mainitut laitteistot / Oświadczka, że wymienione poniżej urządzenia / Prohlašuje, že níže uvedené vybavení / Декларирует, что ниженазванное оборудование:

POMPE PNEUMATIQUE FLOWMAX® & POMPE AIRMIX® FLOWMAX® A MOTEUR AVEC INVERSEUR
/ AIRMIX® FLOWMAX® PUMP & FLOWMAX® LOW PRESSURE PUMP - AIR MOTOR WITH REVERSING BLOCK
/ AIRMIX® PUMPE UND PNEUMATISCHE PUMPE MIT UMSTEUERMOTOR - FLOWMAX®
/ BOMBA NEUMÁTICA FLOWMAX® & BOMBA AIRMIX® FLOWMAX® CON MOTOR CON INVERSOR

20-25 F	
20-50 F	20-50 FT
04-120 F	
08-120 F	08-120 FT
16-120 F	16-120 FT
04-220 F	04-220 FT
	08-220 FT
20-220 F	

Est conforme à la législation d'harmonisation de l'Union applicable suivante / Is in conformity with the relevant Union harmonisation legislation / Erfüllt die einschlägigen Harmonisierungsrechtsvorschriften der Union / es conforme con la legislación de armonización pertinente de la Unión / è conforme alla pertinente normativa di armonizzazione dell'Unione / in overeenstemming met de desbetteffende harmonisatiewetgeving van de Unie / med den relevanta harmoniserade unionslagstiftningen / on asiaa koskevan unionin yhdenmukaistamislainsäädännön vaatimusten mukainen / jest zgodny z odpowiednimi wymaganiami unijnego prawodawstwa harmonizacyjnego / Shoduje se s následující příslušnou evropskou harmonizační legislativou / Соответствует следующим стандартизированным нормам Союза

Directive ATEX / ATEX Directive / ATEX Richtlinie / Directiva ATEX / Direttiva ATEX / Diretiva ATEX / ATEX-Richtlijn / ATEX-direktivet / ATEX-direktivi / Dyrektywa ATEX / Směrnice ATEX / Директива ATEX 	94/9/CE
--	----------------

Dominique LAGOUGE

Directeur Général / Chief Executive Officer / Generaldirektor
 / Director General / Direttore Generale / Director Geral / Algemeen
 Directeur / Generaldirektör / Pääjohtaja / Dyrektor Naczelny
 / Dyrektor Generalny / Generální ředitel / Генеральный директор

Fait à Stains, le / Established in Stains, on / Geschehen zu Stains, am / En Stains, a / Redatto a Stains, / Vastgesteld te Stains, / Utformat i Stains, den / Stains, Ranska, / Sporządzono w Stains, dnia / Stains, dnia / Издано в г. Стен (Stains) 21/01/2010 - 01/21/2010

VALABLE A PARTIR DU 20 AVRIL 2016
 VALID FROM 20 APRIL 2016
 GÜLTIG AB DEM 20. APRIL 2016
 VALIDEZ A PARTIR DEL 20 DE ABRIL DE 2016
 VALIDO A PARTIRE DAL 20 APRILE 2016
 APLICÁVEL A PARTIR DE 20 DE ABRIL DE 2016
 GELDIG VANAF 20 APRIL 2016.
 GÄLLER FRÅN OCH MED DEN 20 APRIL 2016
 VOIMASSA 20.4.2016 ALKAEN
 WAŻNOŚĆ OD 20 KWIETNIA 2016 R.
 PLATÍ OD 20. DUBNA 2016
 ДЕЙСТВИТЕЛЬНО С 20 АПРЕЛЯ 2016 ГОДА



DECLARATION UE DE CONFORMITE
UE DECLARATION OF CONFORMITY
EU-KONFORMITÄTSEKTLÄRUNG
DECLARACIÓN UE DE CONFORMIDAD
DICHIARAZIONE DI CONFORMITÀ UE
DECLARAÇÃO UE DE CONFORMIDADE
EU-CONFORMITEITSVERKLARING
EU-FÖRSÄKRAN OM ÖVERENSSTÄMMESE
EU-VAATIMUKSEN MUKAISUUSVAKUUTUS
DEKLARACJA ZGODNOŚCI UE
EU PROHLÁŠENÍ O SHODĚ
ДЕКЛАРАЦИЯ О СООТВЕТСТВИИ НОРМАМ ЕС

Le fabricant / The manufacturer / Der Hersteller / El fabricante / Il produttore / O fabricante / De fabrikant / Tillverkare / Valmistaja / Producent / Výrobce / Изготовитель:	KREMLIN REXSON 150, avenue de Stalingrad 93 240 - STAINS - FRANCE Tél. 33 (0)1 49 40 25 25 - Fax : 33 (0)1 48 26 07 16
--	--

Déclare que le matériel désigné ci-après / Herewith declares that the equipment / erklårt hiermit, dass die / Declara que el material designado a continuación / Dichiaro che il materiale sottoindicato / Declara que o material a seguir designado / verklaart dat de hieronder aangeduide apparatuur / Kungör att den utrustning som anges här nedan / ilmoittaa, että alla mainitut laitteistot / Oświadczka, że wymienione poniżej urządzenia / Prohlašuje, že níže uvedené vybavení / Декларирует, что ниженазванное оборудование:

POMPE PNEUMATIQUE FLOWMAX® & POMPE AIRMIX® FLOWMAX® A MOTEUR AVEC INVERSEUR
/ AIRMIX® FLOWMAX® PUMP & FLOWMAX® LOW PRESSURE PUMP - AIR MOTOR WITH REVERSING BLOCK
/ AIRMIX® PUMPE UND PNEUMATISCHE PUMPE MIT UMSTEUERMOTOR - FLOWMAX®
/ BOMBA NEUMÁTICA FLOWMAX® & BOMBA AIRMIX® FLOWMAX® CON MOTOR CON INVERSOR

20-25 F	
20-50 F	20-50 FT
04-120 F	
08-120 F	08-120 FT
16-120 F	16-120 FT
04-220 F	04-220 FT
	08-220 FT
20-220 F	

Est conforme à la législation d'harmonisation de l'Union applicable suivante / Is in conformity with the relevant Union harmonisation legislation / Erfüllt die einschlägigen Harmonisierungsrechtsvorschriften der Union / es conforme con la legislación de armonización pertinente de la Unión / è conforme alla pertinente normativa di armonizzazione dell'Unione / in overeenstemming met de desbetreffende harmonisatiewetgeving van de Unie / med den relevanta harmoniserade unionslagstiftningen / on asiaa koskevan unionin yhdenmukaistamislainsäädännön vaatimusten mukainen / jest zgodny z odpowiednimi wymaganiami unijnego prawodawstwa harmonizacyjnego / Shoduje se s následující příslušnou evropskou harmonizační legislativou / Соответствует следующим стандартизированным нормам Союза

Directive ATEX / ATEX Directive / ATEX Richtlinie / Directiva ATEX / Direttiva ATEX / Diretiva ATEX / ATEX-Richtlijn / ATEX-direktivet / ATEX-direktivi / Dyrektywa ATEX / Směrnice ATEX / Директива ATEX		2014/34/UE
Procédure d'évaluation de la conformité : Module A Documentation technique (Annexe VIII) archivée par : / Conformity assessment procedure: Module A Technical documentation (ANNEX VIII) recorded by: / Verfahren zur Konformitätsbewertung: Modul A Technische Unterlagen (ANLAGE VIII) archiviert durch: / Procedimiento de evaluación de la conformidad: Módulo A Documentación técnica (ANEXO VIII) archivada por: / Procedura di valutazione della conformità: Modulo A Documentazione tecnica (ALLEGATO VIII) archiviata a cura di: / Procedimento de avaliação da conformidade: Módulo A Documentação técnica (ANEXO VIII) arquivada por: / Conformiteitsbeoordelingsprocedure: Module A Technische documentatie (BIJLAGE VIII) gearhiveerd door: / Förfarande för bedömning av överensstämmelse: Modul A Teknisk dokumentation (BILAGA VIII) arkiverad av: / Vaatimustenmukaisuusarviointimenetelmä: moduuli A Tekninen dokumentaatio (LIITE VIII) arkistoitu: / Procedura oceny zgodności: Moduł A Dokumentacji technicznej (ZAŁĄCZNIK VIII) zarchiwizowane przez: / Postup posuzování shody: Modul A Technická dokumentace (PŘÍLOHA VIII) archivována: / Процедура оценки соответствия: Модуль A Техническая документация (ПРИЛОЖЕНИЕ VIII), архивированная: ISSeP Zoning A. Schweitzer Rue de la Platinerie B - 7340 COLFONTAINE BELGIQUE		

Dominique LAGOUGE

Directeur Général / Chief Executive Officer / Generaldirektor
 / Director General / Direttore Generale / Director Geral / Algemeen
 Directeur / Generaldirektör / Pääjohtaja / Dyrektor Naczelny
 / Dyrektor Generalny / Generální ředitel / Генеральный директор

Fait à Stains, le / Established in Stains, on / Geschehen zu Stains, am / En Stains, a / Redatto a Stains, / Vastgesteld te Stains, / Utformat i Stains, den / Stains, Ranska, / Sporządzono w Stains, dnia / Stains, dnia / Издано в г. Стен (Stains) 11/04/2016 - 04/11/2016



FLOWMAX® PUMP

04-120 F

Disassembly / Reassembly

TRANSLATION FROM THE ORIGINAL MANUAL

IMPORTANT : Before assembly and start-up, please read and clearly understand all the documents relating to this equipment (professional use only).

THE PICTURES AND DRAWINGS ARE NON CONTRACTUAL. WE RESERVE THE RIGHT TO MAKE CHANGES WITHOUT PRIOR NOTICE.

KREMLIN - REXSON

150, avenue de Stalingrad

93 245 - STAINS CEDEX - France

☎ : 33 (0)1 49 40 25 25 Fax : 33 (0)1 48 26 07 16

www.kremlin-rexson.com



CAUTION :

Before any action on the pump, shut off the compressed air supply and depressurize the system.

The pump is manufactured under the ATEX agreement and can not be modified. KREMLIN REXSON will not be held responsible for any failure to comply with that instruction.

DISASSEMBLY / REASSEMBLY OF THE FLUID SECTION

Guards (air motor cover, coupling shields, housings ...) have been designed for safe use of the equipment.

The manufacturer will not be held responsible for bodily injury or failure and / or damage to property due to removal or partial removal of the guards

Unscrew fitting (39) and screws (43 & 45) to remove attachment fluid tube (41).

■ **SUCTION VALVE (REFER TO DOC. 573.113.050)**

Unscrew suction valve (28) - (If cylinder (22) remains attached to the suction valve, unscrew both parts. Then, hold cylinder (22) by inserting a rod into the cylinder holes designed for this purpose).

The ball (29) is secured on the valve (28) by means of a circlips (30).

Clean the parts.

Reinstall suction valve (28) and seal (31). Replace them if necessary.

■ **CYLINDER**

In order to make easier the disassembly, a hole is drilled in the cylinder (22) at each end.

In relation to the part which is unscrewed first, insert a rod into one of these holes to unscrew the other part.

When reassembling be certain the two seals (25 and 31) are installed.

■ **EXHAUST VALVE AND MOBILE PACKING**

Unscrew cylinder (22) and pull it downwards.

Unscrew exhaust valve (24) by holding piston (21).

Remove ball (33) and mobile packing (cup seal ind. 23)

Clean the parts and reinstall them. Replace seals if necessary.

■ **UPPER TIGHTNESS SEAL**

Unscrew the four screws (26).

Remove tightness seal (27) by pulling discharge flange (20) downwards.

Change tightness seal (27), O-Rings (25 and 11).

Reinstall the parts in the reverse order of the disassembly sequence.

DISASSEMBLY / REASSEMBLY OF THE COUPLING (BELLOWS)

Guards (air motor cover, coupling shields, housings ...) have been designed for safe use of the equipment.

The manufacturer will not be held responsible for bodily injury or failure and / or damage to property due to removal or partial removal of the guards

Disassemble the fluid section prior to carrying out the following procedure :

■ BELLOWS

Unscrew nuts (14) from the tie-rods.

Remove suction flange (1) and cylinder (2) by pulling them downwards.

Remove screws (12) to disconnect suction bearing (3) from air motor.

Disconnect intermediate piston (9) from air motor rod.

Remove coupling parts.

Remove bellows flange (4) by unscrewing screws (13) to free the upper part of the bellows.

Unscrew skirt (8) to free the lower part of the bellows.

Replace bellows (5).

When installing bellows push it into skirt firmly (8) .

Insert intermediate piston (9) into bellows (5) and screw the skirt at the piston end.

Insert bellows and piston (9) into the suction bearing (3).

Install flange (4) in the suction bearing and tighten the whole with screws (13).

Connect bellows-piston set to motor rod and secure the whole on the lower support of the air motor by using screws (12).

Reinstall fluid section piston (21) on intermediate piston (9).

Replace seals (11). Then install cylinder (2) and suction flange (1).

Install the whole on tie-rods and tighten it with nuts (14).

AIR MOTOR

Guards (air motor cover, coupling shields, housings ...) have been designed for safe use of the equipment.
The manufacturer will not be held responsible for bodily injury or failure and / or damage to property due to removal or partial removal of the guards

■ REVERSING BLOCK (MOTOR) (REFER TO DOC. 573.031.050)

Disassemble cover (32) by removing screws CHc (33).

Dissociate female yoke (12) from reversing block lever (9).

Dismount reversing block by removing screws (10 and 8).

Reinstall the new reversing block in the reverse order of the disassembly sequence.

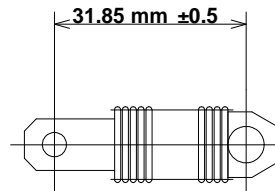

⚠ **CAUTION :** The number of spirals must equally be distributed on each fastening parts in order to get the above dimension.

Before reassembling the different components :

- Clean the parts with the appropriate cleaning solvent.
- Install new seals if it is necessary, after having lubricated them with PTFE grease.
- Lubricate the piston and the inside of the cylinder to prevent from damaging the seals.
- Install new parts if it is necessary.

■ ASSEMBLY INSTRUCTIONS

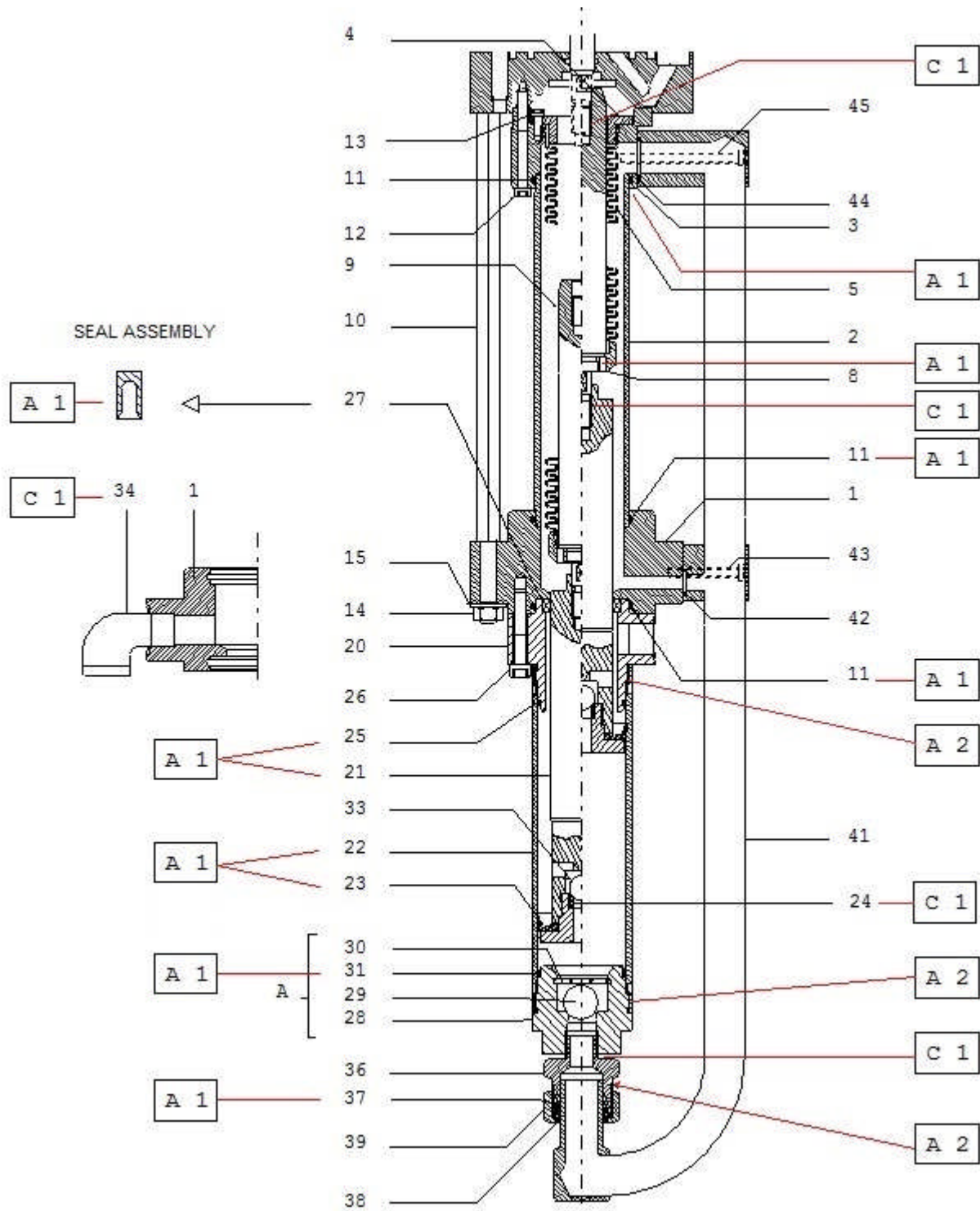

Index	Instruction	Description	Part number
A 1	PTFE grease	'TECHNILUB' grease (10 ml)	560.440.101
A 2	Anti-seize grease	Grease box (450 g / 0.99 lb)	560.420.005
C 1	Medium strength Aneorobic Pipe sealant	Loctite 577	554.180.015

Doc. 573.118.050 Date/Datum/Fecha : 16/04/12 Annule/Cancela/ Ersetzt/Anula : 28/08/08	Modif. / Änderung : Mise à jour / Update / Aktualisierung / Actualización	Pièces de rechange Spare parts list Ersatzteilliste Piezas de repuesto
---	--	---

POMPE FLOWMAX®, modèle 04-120 F	FLOWMAX® PUMP, model 04-120 F
FLOWMAX® PUMPE, Modell 04-120 F	BOMBA FLOWMAX®, tipo 04-120 F

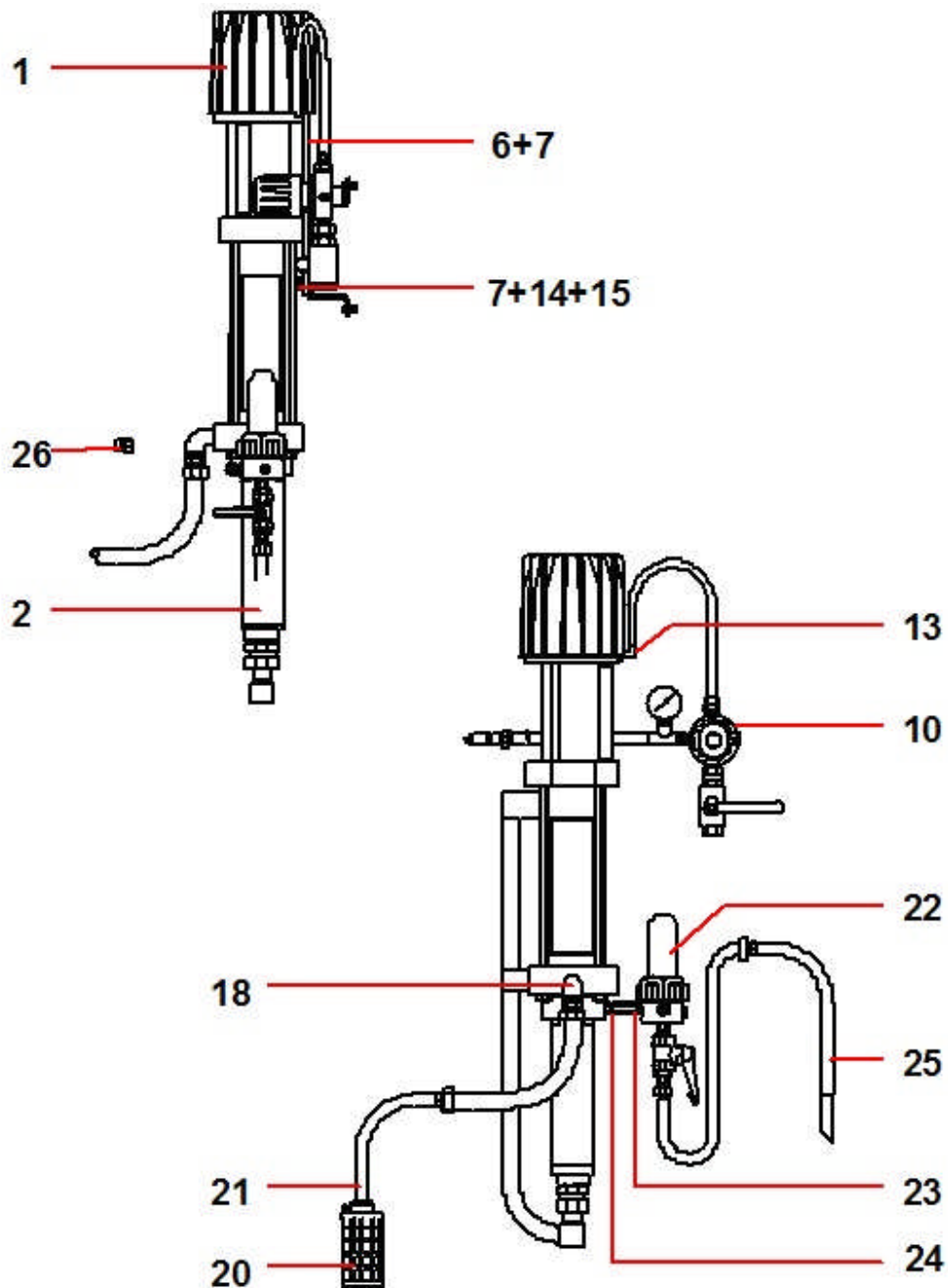

POMPE MURALE, modèle 04-120 F sans filtre, ni cannes	WALL MOUNTED PUMP, model 04-120 F without filter or rods	# 151.795.100
WANDANLAGE, Modell 04-120 F ohne Filter und Schläuche	BOMBA MURAL, tipo 04-120 F sin filtro y cañas	

Ind	#	Désignation	Description	Bezeichnung	Denominación	Qté
-	151.795.000	Pompe 04.120 F nue	Bare pump, model 04.120 F	Pumpe 04.120 F, nackt	Bomba sola, tipo 04.120 F	1
* 1	146.260.000	▪ Moteur 500-4 (voir Doc. 573.031.050)	▪ Air motor, model 500-4 (refer to Doc. 573.031.050)	▪ Luftmotor 500-4 (siehe Dok. 573.031.050)	▪ Motor, tipo 500-4 (consultar Doc. 573.031.050)	1
* 2	144.970.100	▪ Hydraulique FLOWMAX 120 F (voir Doc. 573.113.050)	▪ Fluid section, model FLOWMAX 120 F (refer to Doc. 573.113.050)	▪ FLOWMAX Hydraulikteil 120 F (siehe Dok. 573.113.050)	▪ Hidráulica FLOWMAX 120 F (consultar Doc. 573.113.050)	1
6	051.770.101	Plaque d'interface	Plate	Umsteuerplatte	Placa	1
7	933.011.279	Vis M 8 x 20	Screw, M 8 x 20	Schraube M 8 x 20	Tornillo M 8 x 20	2
10	151.790.170	Equipement d'air (air moteur) (voir Doc. 573.403.050)	Air supply (motor air) (refer to Doc. 573.403.050)	Luftausrüstung (Luftmotor) (siehe Dok. 573.403.050)	Equipo de aire (aire motor) (consultar Doc. 573.403.050)	1
13	905.150.012	Raccord coudé cannelé M 1/4 BSP - T 8x12	Elbow connector M 1/4 BSP - T 8x12	Winkelnippel, AG 1/4 BSP - T 8x12	Racor acodado M 1/4 BSP - T 8x12	1
14	963.040.019	Rondelle MN 8	Washer, MN 8	Scheibe MN 8	Arandela MN 8	2
15	953.010.019	Ecrou HM 8	Nut, HM 8	Mutter HM 8	Tuerca HM 8	2
18	050.102.437	Raccord inox M 1/2" BSP - M 26 x 125 (entrée produit)	Fitting, stainless steel, double male, 1/2" BSP - 26 x 125 (fluid inlet)	Doppelnippel, Edelstahl AG 1/2" BSP - M 26 x 1,25 (Materialeingang)	Racor inox M 1/2" BSP - M 26 x 125 (entrada producto)	1

* Pièces de maintenance préconisées tenues en stock

* Preceding the index number denotes a suggested spare part.

* Bezeichnete Teile sind empfohlene Ersatzteile.

* Piezas de mantenimiento preventivas a tener en stock.

Nota : Dans le cas d'une pompe nue pour fixation murale, commander la pompe nue et le support réf. 044.910.121 (rep. 1 - Doc. 573.403.050).

Nota : For a bare pump with wall bracket, order bare pump and bracket – P.N°. 044.910.121 (ind. 1 - Doc. 573.403.050).

Anmerkung : Bei einer nackten Pumpe für Wandhalterung, bestellen Sie die nackte Pumpe und die Halterung, Bestell-Nr. 044.910.121 (ind. 1 - Dok. 573.403.050)

Nota : En caso de una bomba sola con fijación mural, encargue Vd. la bomba sola y el soporte con la referencia 044.910.121 (índ. 1 - Doc. 573.403.050).

POMPE MURALE, modèle 04-120 F avec filtre et cannes	WALL MOUNTED PUMP, model 04-120 F with filter and rods	#
WANDANLAGE , Modell 04-120 F mit Filter und Schläuche	BOMBA MURAL, tipo 04-120 F con filtro y cañas	151.795.200

Ind	#	Désignation	Description	Bezeichnung	Denominación	Qté
-	151.795.100	Pompe murale sans filtre, ni cannes	Wall mounted pump without filter or rods	Wandpumpe ohne Filter und Schläuche	Bomba mural sin filtro ni cañas	1
20	049.596.110	Canne d'aspiration inox avec crépine	Suction rod (stainless steel) with strainer	Saugschlauch, Edelstahl mit Siebkorb	Caña de aspiración inox con piña	1
21	149.591.400	▪ Crépine avec manchon	▪ Strainer with sleeve	▪ Siebkorb	▪ Piña con manguito	1
22	155.580.300	Filtre AIRMIX® inox 3/8 (voir Doc.573.299.050)	AIRMIX® filter 3/8, stainless steel (refer to Doc.573.299.050)	AIRMIX® Filter, 3/8 Edelstahl (siehe Dok.573.299.050)	Filtro AIRMIX® inox 3/8 (consultar Doc.573.299.050)	1
23	055.580.301	Manchon inox MM 3/8 NPT	Sleeve, stainless steel MM 3/8 NPT	Muffe, Edelstahl AG 3/8 NPT	Manguito inox MM 3/8 NPT	1
24	905.210.203	Raccord inox M 1/2 BSP - F 3/8 BSP	Fitting, stainless steel M 1/2 BSP - F 3/8 BSP	Nippel, Edelstahl AG 1/2 BSP - IG 3/8 BSP	Racor inox M 1/2 BSP - H 3/8 BSP	1
25	049.596.000	Canne de purge inox	Drain rod, stainless steel	Entleerungsschlauch, Edelstahl	Caña de purga inox	1
26	050.123.533	Raccord M 3/8 NPS - F 1/2 JIC	Fitting, M 3/8 NPS - F 1/2 JIC	Nippel AG 3/8 NPS - IG 1/2 JIC	Racor , M 3/8 NPS - H 1/2 JIC	1

POMPE 04-120 F SUR CHARIOT	CART MOUNTED PUMP, model 04-120 F	#
PUMPE 04-120 F FAHRBAR	BOMBA 04-120 F SOBRE CARRETILLA	151.795.400

Ind	#	Désignation	Description	Bezeichnung	Denominación	Qté
-	151.795.200	Pompe murale avec filtre et cannes	Wall mounted pump with filter and rods	Wandpumpe mit Filter und Schläuche	Bomba mural con filtro y cañas	1
-	051.221.000	Chariot (2 bras)	Cart (2 arms)	Fahrgestell (2 Arme)	Carretilla (2 brazos)	1
	056.100.199	Panneau de fixation	Wall bracket unit	Wandplatte	Soporte de fijación	1

Doc. 573.031.050 Date/Datum/Fecha : 12/05/14 Annule/Cancela/ Ersetzt/Anula : 13/03/12	Modif. / Änderung : # 146.260.990, # 146.260.995 + Nota / Hinweis	Pièces de rechange Spare parts list Ersatzteilliste Piezas de repuesto
---	--	---

MOTEUR A AIR, modèle 500-4	AIR MOTOR, model 500-4	#
LUFTMOTOR, Modell 500-4	MOTOR DE AIRE, tipo 500-4	146.260.000

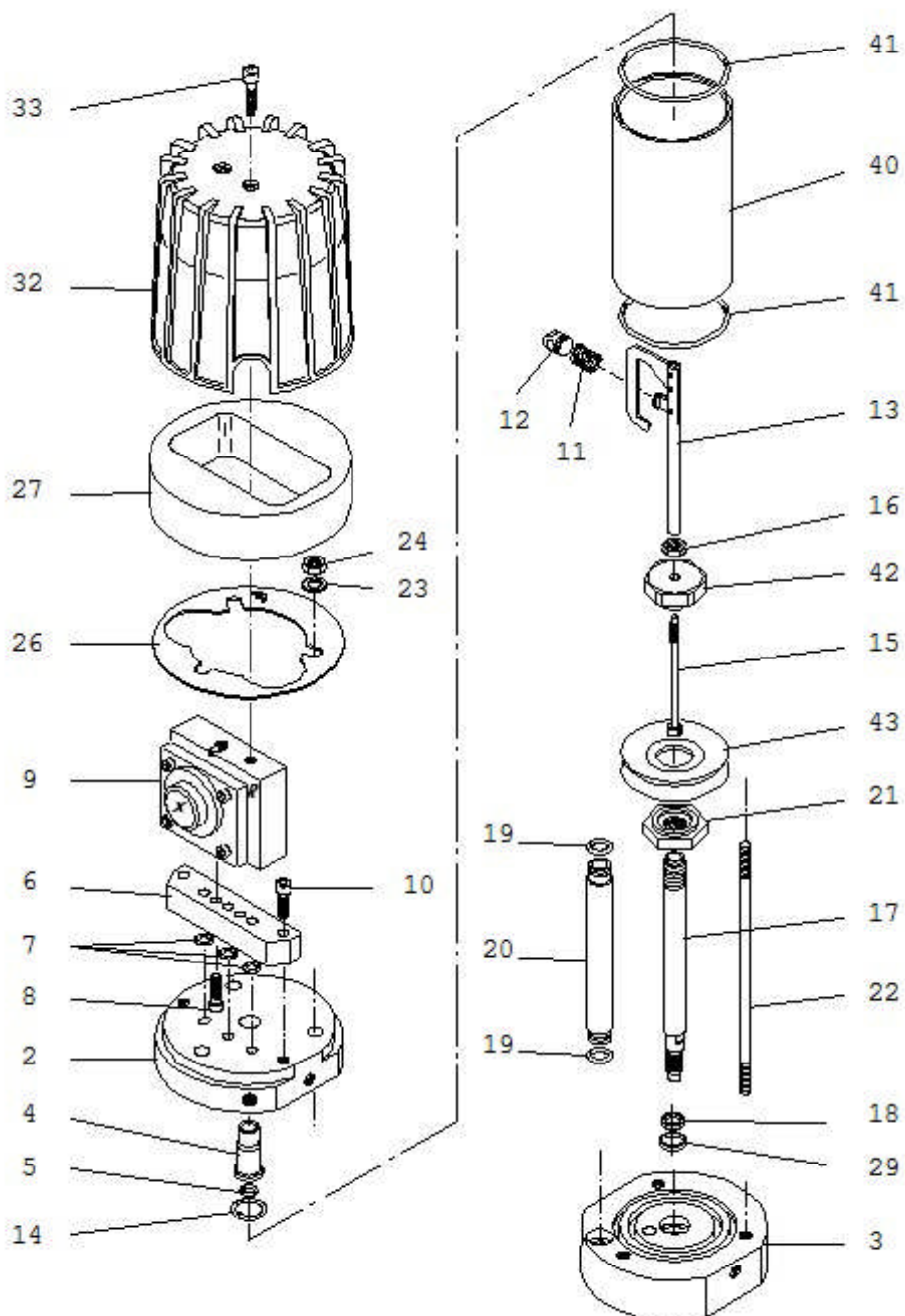

MOTEUR A AIR, modèle 500-4	AIR MOTOR, model 500-4	# 146.260.000
LUFTMOTOR, Modell 500-4	MOTOR DE AIRE, tipo 500-4	

Ind	#	Désignation	Description	Bezeichnung	Denominación	Qté
2	046 260 901	Fond supérieur	Upper flange	Oberer Flansch	Fondo superior	1
3	146 260 902	Fond inférieur	Lower flange	Unterer Flansch	Fondo inferior	1
4	044 570 106	Bague de guidage	Guide ring	Führungsbuchse	Anillo guía	1
5	144 579 923	Bague R 8 bis (x10)	Ring, R 8 bis (x10)	O-Ring R 8 bis (10Stck)	Anillo R 8 bis (x10)	1
6	046 230 005	Embase bloc inverseur	Base, reversing-block	Grundplatte, Umsteuerblock	Base bloque inversor	1
7	109 420 257	Bague O Ring (x10)	O Ring (x10)	O-Ring (10Stck)	Anillo O Ring (x10)	3
8	933 151 277	Vis CHc M 6 x 20	Screw, CHc M 6 x 20	Schraube CHc M 6 x 20	Tornillo CHc M 6 x 20	2
*9	044 630 400	Ensemble bloc inverseur (voir Doc. 573.087.040)	Reversing-block (refer to Doc. 573.087.040)	Umsteuerblock komplett (siehe Dok. 573.087.040)	Conjunto bloque inversor (consultar Doc. 573.087.040)	1
10	930 151 446	Vis CHc M 8 x 35	Screw, CHc M 8 x 35	Schraube CHc M 8 x 35	Tornillo, CHc M 8 x 35	2
11	050 311 232	Ressort	Spring	Feder	Muelle	1
12	044 570 131	Chape femelle	Linkage, female	Federhalterung	Unión hembra	1
13	044 570 900	Fourchette de commande équipée	Control fork assembly	Umsteuerstange komplett	Horquilla de mando equipada	1
14	902 202 002	Anneau truarc	Retaining ring	Sicherungsring	Anillo truarc	1
15	046 180 003	Tige de pilotage	Rod, driving	Steuerstange	Eje de mando	1
16	046 144 907	Ecrou	Nut	Mutter	Tuerca	1
17	046 180 007	Tige de piston	Rod, piston	Luftkolbenstange	Eje de pistón	1
18	046 180 010	Bague de frottement	Seal, ring	Abstreifring	Anillo de deslizamiento	1
19	129 400 902	Joint (x10)	Seal (x10)	Dichtringe (10 Stck)	Junta (x10)	2
20	046 144 901	Tube d'alimentation	Tube,connecting	Luftverbindungsrohr	Tubo de alimentación	1
21	000 323 716	Contre écrou inférieur	Lower locknut	Untere Kontermutter	Contratuerca inferior	1
22	046 180 009	Tirant	Tie-rod	Verbindungsstange	Tirante	3
23	963 040 021	Rondelle MN 10	Washer, MN 10	Scheibe MN 10	Arandela MN 10	3
24	953 010 021	Ecrou HM 10	Nut, HM 10	Mutter HM 10	Tuerca HM 10	3
26	046 260 903	Rondelle de maintien	Seal	Flachdichtung	Arandela	1
27	046 230 007	Silencieux	Silencer	Schalldämpfer	Silenciador	1
29	909 420 291	Joint	Seal	Dichtring	Junta	1
32	044 570 135	Cloche	Cover	Schutzhaube	Campana	1
33	933 151 387	Vis CHc M 6 x 30	Screw, CHc M 6 x 30	Schraube CHc M 6 x 30	Tornillo CHc M 6 x 30	2
*40	046 260 001	Cylindre	Cylinder	Luftzylinder	Cilindro	1
41	000 323 061	Joint de cylindre	Seal, cylinder	Zylinder - O-Ring	Junta de cilindro	2
42	046 144 908	Ecrou de piston	Nut, piston	Obere Kolbenmutter	Tuerca de pistón	1
43	046 140 002	Piston	Piston	Luftkolben	Pistón	1
-	901 180 024	Cable de mise à la terre (Lg. 5 m)	Ground (Length 5 m / 196.85")	Erdungskabel (Länge 5m)	Cable de puesta a tierra (5 m de largo)	1

Ind	#	Désignation	Description	Bezeichnung	Denominación	Qté
*	146 260 990	Pochette de joints moteur (ind. 5, 7(x3), 11, 18, 19(x2), 29, 41(x2) + pochette de joints inverseur)	Package of seals of the air motor (ind. 5, 7(x3), 11, 18, 19(x2), 29, 41(x2) + package of seals of the reversing block)	Dichtungssatz Motor (Pos. 5, 7(x3), 11, 18, 19(x2), 29, 41(x2) + Dichtungssatz für Umsteuerblock)	Bolsa de juntas motor (ind. 5, 7(x3), 11, 18, 19(x2), 29, 41(x2) + bolsa de juntas del inversor)	1
*	146 260 995	Pochette de maintenance (ind. 4, 43 + pochette de joints moteur + ind. 2, 4, 7, 8, 13 de l'inverseur)	Servicing kit (ind. 4, 43, + package of seals of the air motor + ind. 2, 4, 7, 8, 13 of the reversing block)	Servicekit (Pos. 4, 43 + Dichtungssatz Luftmotor + Pos. 2, 4, 7, 8, 13 vom Umsteuerblock)	Bolsa de mantenimiento (ind. 4, 43 + bolsa de juntas motor + ind. 2, 4, 7, 8, 13 del inversor)	1

* Pièces de maintenance préconisées.

* Preceding the index number denotes a suggested spare part.

* Bezeichnete Teile sind empfohlene Ersatzteile.

* Piezas de mantenimiento preventivas.

Nota : Ne monter l'ind. 2 (bague de guidage du bloc inverseur) contenu dans la pochette de maintenance 146 260 995 que pour les pompes avec numéros de série < 14 AF 1025, < 14 H 1110 et/ou si votre bloc inverseur ne comporte pas de R.

Nota : Install ind. 2 (guide ring of the reversing-block) of the servicing kit 146 260 995 only for the pumps with serial numbers < 14 AF 1025, < 14 H 1110 and/or if your reversing-block does not have R.

Hinweis: Die Pos. 2 (Führungsring Umsteuerblock) vom Servicekit 146 260 995, **nur** bei den Pumpen mit den Serien Nummern < 14 AF 1025, < 14 H 1110 und/oder bei den Umsteuerblocks **ohne** R Markierung, montieren.

Nota : Montar el ind. 2 (anillo guía del bloque inversor) que está en la bolsa de mantenimiento 146 260 995 para las bombas con números de serie < 14 AF 1025, < 14 H 1110 y/o si su bloque inversor no tiene R.

Doc. 573.087.040 Date/Datum/Fecha : 03/06/14 Annule/Cancel/ Ersetzt/Anula : 03/01/14	Modif. / Änderung : Eclaté / Exploded view / Explosions- zeichnung / Vista	Pièces de rechange Spare parts list Ersatzteilliste Piezas de repuesto
--	---	---

BLOC INVERSEUR	REVERSING-BLOCK	#
UMSTUEURBLOCK	BLOQUE INVERSOR	044.630.400

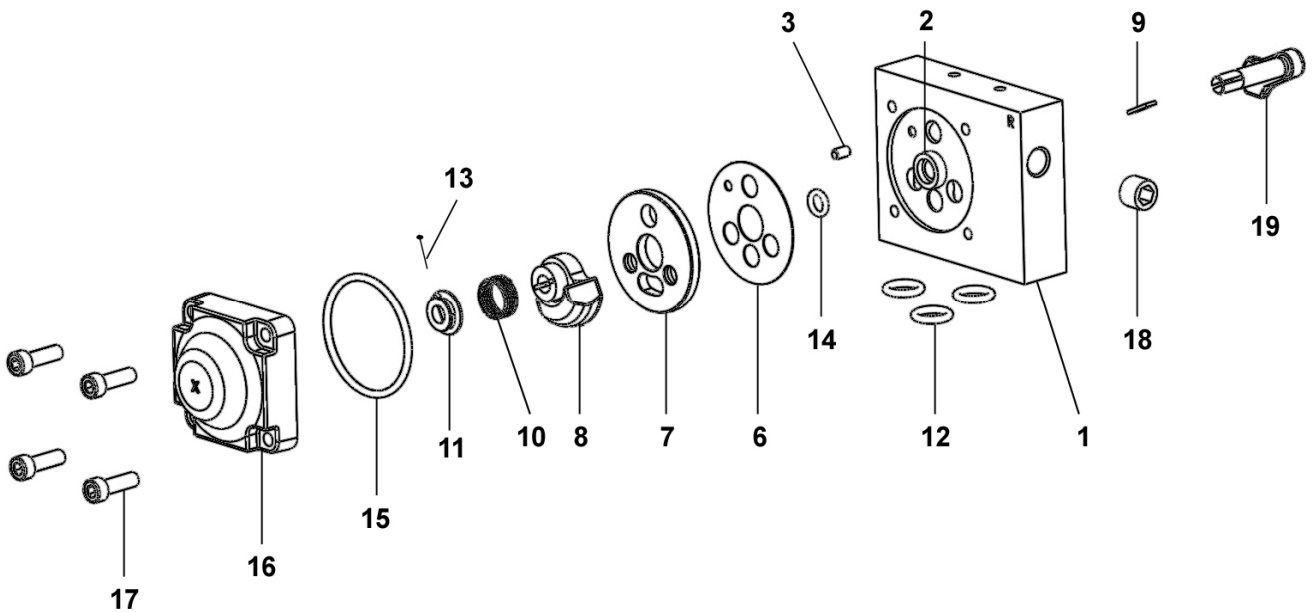

BLOC INVERSEUR	REVERSING-BLOCK	# 044.630.400
UMSTUEURBLOCK	BLOQUE INVERSOR	

Ind	#	Désignation	Description	Bezeichnung	Denominación	Qté
*	144 630 410	Corps équipé	Block assembly, reversing	Umsteuerblock komplett	Cuerpo equipado	1
1	N C / N S	▪ Corps	▪ Body	▪ Körper	▪ Cuerpo	1
2	N C / N S	▪ Bague de guidage	▪ Guide ring	▪ Führungsbuchse	▪ Anillo guía	1
3	N C / N S	▪ Goupille Ø 4 x 8	▪ Pin Ø 4 x 8	▪ Splint Ø4 x 8	▪ Pasador Ø 4 x 8	1
-	N C / N S	▪ Butée (collée sur corps ind.2)	▪ Stop (glued on part ind. 2)	▪ Anschlag (auf Körper geklebt ind.2)	▪ Tope (pegado en cuerpo ind. 2)	2
-	N C / N S	▪ Roulement à bille	▪ Ball bearing	▪ Kugellager	▪ Rodamiento de bolas	1
*6	144 579 912	Joint de glace fixe (x 10)	Gasket seal (x 10)	Flachdichtung (x 10)	Junta de espejo fijo (x 10)	1
*7	046 170 508	Glace fixe	Base, fixed	Ventilplatte	Espejo fijo	1
*8	044 570 324	Glace mobile	Base, mobile	Ventilschieber	Espejo móvil	1
9	044 570 325	Clavette	Pin	Paßfeder (Keil)	Pasador	1
10	921 140 102	Ressort	Spring	Feder	Muelle	1
11	044 571 006	Butée de ressort	Stop, spring	Federführung	Tope de muelle	1
*12	144 579 922	Bague R 10 (x 10)	Ring, R 10 (x 10)	O Ring R 10 (x 10)	Anillo, R 10 (x 10)	3
*13	144 579 911	Goupille fendue (pochette de 10 goupilles + 1 butée ind. 11)	Pin (package of 10 pins + 1 stop ind. 11)	Splint (Satz à 10 Stück + 1 Führung Pos. 11)	Pasador (bolsa de 10 pasadores + 1 tope ind. 11)	1
*14	144 579 910	Bague R 6a (x 10)	Ring, R 6a (x 10)	O Ring, R 6a (x 10)	Anillo, R 6a (x 10)	1
*15	N C / N S	Joint de couvercle	Seal, cover	Deckeldichtung	Junta de tapa	1
16	144 630 415	Couvercle	Cover	Deckel	Tapa	1
17	933 151 277	Vis CHc M 6x20	Screw, CHc M 6x20	Schraube, CHc M 6x20	Tornillo, CHc M 6x20	4
18	906 333 102	Bouchon 1/4 BSP	Plug, 1/4 BSP	Blindstopfen, 1/4 BSP	Tapón, 1/4 BSP	1
19	046 170 510	Levier	Lever, control	Umsteuerhebel	Leva	1

*	146 270 950	Pochette de joints (ind. 6, 12(x3), 14, 15)	Package of seals (ind. 6, 12(x3), 14, 15)	Dichtungssatz (bestehend aus Pos. 6, 12(x3), 14, 15)	Bolsa de juntas (ind. 6, 12(x3), 14, 15)	1
*	144 630 425	Pochette de maintenance glaces (ind. 7, 8)	Servicing kit - bases (ind. 7, 8)	Servicekit - Ventil (Pos. 7, 8)	Bolsa de mantenimiento - espejos (ind. 7, 8)	1

* Pièces de maintenance préconisées.

* Preceding the index number denotes a suggested spare part.

* Bezeichnete Teile sind empfohlene Ersatzteile.

* Piezas de mantenimiento preventivas.

N C : Non commercialisé.

N S : Denotes parts are not serviceable.

N S : Bezeichnete Teile gibt es nicht einzeln, sondern nur komplett.

N S : no suministrado.

Doc. 573.113.050 Date/Datum/Fecha : 18/11/14 Annule/Cancela/ Ersetzt/Anula : 16/04/12	Modif. / Änderung : Mise à jour / Update / Aktualisierung / Actualización	Pièces de rechange Spare parts list Ersatzteilliste Piezas de repuesto
---	--	---

120 F	HYDRAULIQUE FLOWMAX® / FLOWMAX® FLUID SECTION FLOWMAX® HYDRAULIKTEIL / HIDRÁULICA FLOWMAX®	# 144.970.100
--------------	---	--------------------------------

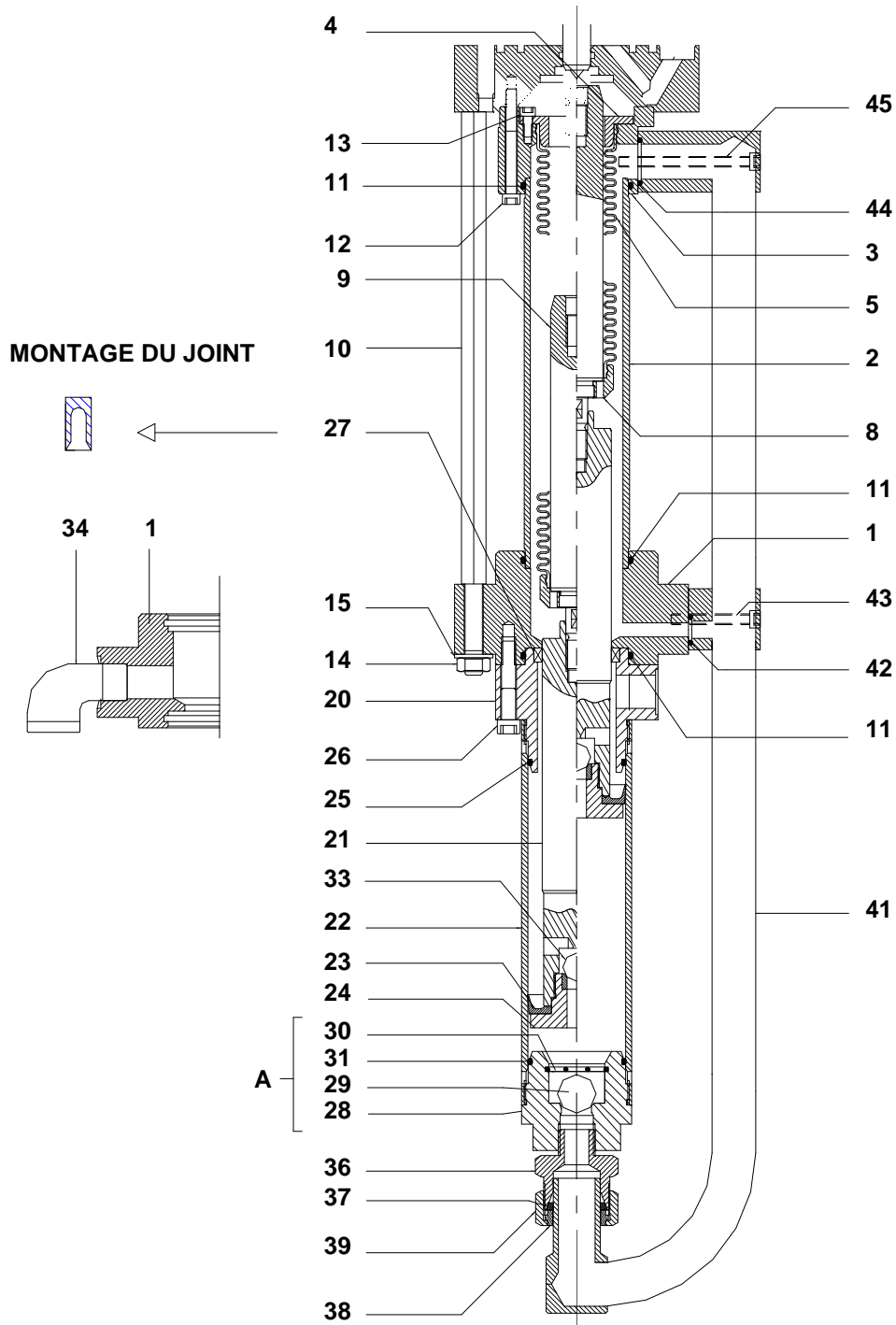

Ind	#	Désignation	Description	Bezeichnung	Denominación	Qté
1	044 970 451	Bride d'aspiration	Suction flange	Unterer Flansch	Brida de aspiración	1
2	044 970 052	Cylindre	Cylinder	Ansaugzylinder	Cilindro	1
3	044 970 445	Palier d'aspiration	Suction bearing	Oberer Flansch	Palier de aspiración	1
4	044 970 046	Bride soufflet	Flange, bellows	Faltenbalg-Flansch	Brida fuelle	1
*5	044 970 055	Soufflet	Bellows	Faltenbalg	Fuelle	1
8	044 970 047	Jupe	Skirt	Klemmstück	Faldón	1
9	044 970 049	Piston intermédiaire	Intermediate piston	Zwischenkolben	Pistón intermediario	1
10	044 970 060	Tirant d'accouplement	Coupling rod	Steuerstange	Tirante de acoplamiento	4
11	050 040 323	Joint PTFE	PTFE seal	Dichtung PTFE	Junta PTFE	3
12	930 151 598	Vis CHc M 6x60	Screw, CHc M 6x60	Schraube M 6x60	Tornillo CHc M 6x60	4
13	931 151 168	Vis CHc M 5x12	Screw, CHc M 5x12	Schraube M 5x12	Tornillo CHc M 5x12	4
14	953 020 021	Ecrou HM 10	Nut, HM 10	Mutter M 10	Tuerca HM 10	4
15	963 040 021	Rondelle M 10	Washer, M 10	Scheibe M 10	Arandela Z M 10	4
20	044 970 101	Bride de refoulement	Discharge flange	Druckflansch	Brida de expulsión	1
*21	044 970 102	Piston	Piston	Kolben	Pistón	1
*22	044 970 002	Cylindre	Cylinder	Materialzylinder	Cilindro	1
23	044 970 008	Joint coupelle (PEHD)	Cup seal (UHMW)	Kolbenmanschette (PEHD)	Junta de copa (PEHD)	1
24	044 970 010	Clapet de refoulement	Discharge valve	Druckventil	Válvula de expulsión	1
25	050 040 319	Joint torique	O-Ring	O-Ring	Junta tórica	1
26	933 151 526	Vis CHc M 8 x 45	Screw, CHc M 8 x 45	Schraube M 8 x 45	Tornillo CHc M 8 x 45	4
27	909 150 228	Joint GT	GT seal	GT-Dichtung	Junta GT	1
*A	144 970 030	Clapet d'aspiration assemblé (1/2 ")	Suction valve assembly (1/2 ")	Ansaugventil komplett (1/2 ")	Válvula de aspiración montada (1/2 ")	1
28	NC / NS	▪ Corps de clapet	▪ Suction valve body	▪ Ansaugventilkörper	▪ Cuerpo de válvula	1
29	907 414 269	▪ Bille Ø 27,7, inox 440C	▪ Ball Ø 27,7, stainless steel 440C	▪ Kugel Ø 27,7, Edelstahl 440C	▪ Bola Ø 27,7, inox 440C	1
30	044 695 010	▪ Jonc	▪ Stop ring	▪ Sicherungsring	▪ Anillo de retención bola	1
31	050 040 319	▪ Joint torique PTFE	▪ PTFE O-Ring	▪ O-Ring PTFE	▪ Junta tórica PTFE	1
33	907 414 242	Bille Ø 16, inox 440C	Ball Ø 16, stainless steel 440C	Kugel Ø 16, Edelstahl	Bola Ø 16, inox 440C	1
34	905 210 403	Coude inox MF 1/2	Elbow, stainless steel, MF 1/2	Winkel 1/2" IG X AG, Edelstahl	Codo MH 1/2 inox	1
36	044 970 105	Raccord M 1/2 BSP - M 38x150	Fitting, double male, 1/2 BSP - 38 x 150	Einschraubnippel AG 1/2" - M 38 x 1,5	Racor, M 1/2 - M 38x150	1
37	144 970 106	Joint (les 10)	Seal (pack of 10)	O-Ring (10 St.)	Junta (bolsa de 10)	1
38	044 970 107	Bague de serrage	Tightening ring	Klemmring	Anillo de apriete	1
39	049 595 306	Ecrou raccord M 38x150	Nut, fitting M 38x150	Überwurfmutter M38x1,5	Tuerca racor M 38x150	1
41	044 970 476	Tube de liaison	Fluid tube, attachment	Verbindungsrohr	Tubo de unión	1
42	129 489 902	Joint PTFE (les 10)	PTFE seal (pack of 10)	Dichtung PTFE (10 St.)	Junta PTFE (bolsa de 10)	1
43	933 151 523	Vis CHc M 6x45	Screw, CHc M 6x45	Schraube M 6x45	Tornillo CHc M 6x45	2
44	150 040 321	Joint PTFE (les 10)	Seal, PTFE (pack of 10)	Dichtung PTFE (10 St.)	Junta PTFE (bolsa de 10)	1
45	933 151 668	Vis CHc M 6x75	Screw, CHc M 6x75	Schraube M 6x75	Tornillo CHc M 6x75	2

Ind	#	Désignation	Description	Bezeichnung	Denominación	Qté
*	144 970 490	Pochette de joints (ind. 11, 23, 25, 27, 29, 30, 31, 33, 37, 42, 44)	Package of seals (ind. 11, 23, 25, 27, 29, 30, 31, 33, 37, 42, 44)	Dichtungssatz (beinhaltet Pos. 11, 23, 25, 27, 29, 30, 31, 33, 37, 42, 44)	Bolsa de juntas (ind. 11, 23, 25, 27, 29, 30, 31, 33, 37, 42, 44)	1
*	144 970 495	Pochette de maintenance (ind. 24, A + pochette de joints)	Servicing kit (ind. 24, A + package of seals)	Servicekit (beinhaltet Pos. 24, A und den Dichtungssatz)	Bolsa de mantenimiento (ind. 24, A + bolsa de juntas)	1

OPTION - ON REQUEST - OPTIONEN - OPCIÓN

Ind	#	Désignation	Description	Bezeichnung	Denominación	Qté
33	907 414 142	Bille Ø 16 (inox 316L)	Ball Ø 16 (316L stainless steel)	Kugel Ø 16 (Edelstahl 316L)	Bola Ø 16 (inox 316L)	1

**POUR PRODUIT HYDRO / FOR HYDRO MATERIAL / FÜR HYDROMATERIALEN
/ PARA PRODUCTO HIDRO**

Ind	#	Désignation	Description	Bezeichnung	Denominación	Qté
*-	144 970 260	Ensemble adaptation pour joints PU	Adaptation assembly for Polyurethane seals	Anpassungseinheit für PU-Dichtungen	Conjunto adaptación para juntas de Poliuretano	1
27	NC / NS	▪ Joint PU	▪ Polyurethane seal	▪ PU-Dichtung	▪ Junta Poliuretano	1
60	NC / NS	▪ Joint de piston (PU)	▪ Piston seal (Polyurethane)	▪ Kolbendichtung (PU)	▪ Junta de pistón (Poliuretano))	1
61	NC / NS	▪ Porte-joint	▪ Seal holder	▪ Dichtungshalterung	▪ Porta junta	1
62	NC / NS	▪ Joint (PTFE)	▪ Seal (PTFE)	▪ Dichtung (PTFE)	▪ Junta (PTFE)	1
63	NC / NS	▪ Bague anti-extrusion	▪ Anti-extrusion ring	▪ Anti-Extrusion Ring	▪ Anillo anti-extrusión	1
		<i>Pour hydraulique 120</i>	<i>For fluid section, model 120</i>	<i>Für Hydraulikteil, Modell 120F</i>	<i>Para hidráulica 120</i>	
70	NC / NS	▪ Corps de cartouche	▪ Cartridge body	▪ Packungskörper	▪ Cuerpo de cartucho	1
72	NC / NS	▪ Segment	▪ Segment	▪ Ring	▪ Segmento	2
73	NC / NS	▪ O ring noir	▪ Black O-Ring	▪ O-Ring (schwarz)	▪ Junta tórica negra	1

* Pièces de maintenance préconisées.

* Preceding the index number denotes a suggested spare part.

* Bezeichnete Teile sind empfohlene Ersatzteile.

* Piezas de mantenimiento preventivas.

NC : Non commercialisé.

NS : Denotes parts are not serviceable separately.

NS : bezeichnete Teile gibt nicht einzeln, sondern nur
komplett.

NS : no suministrado.

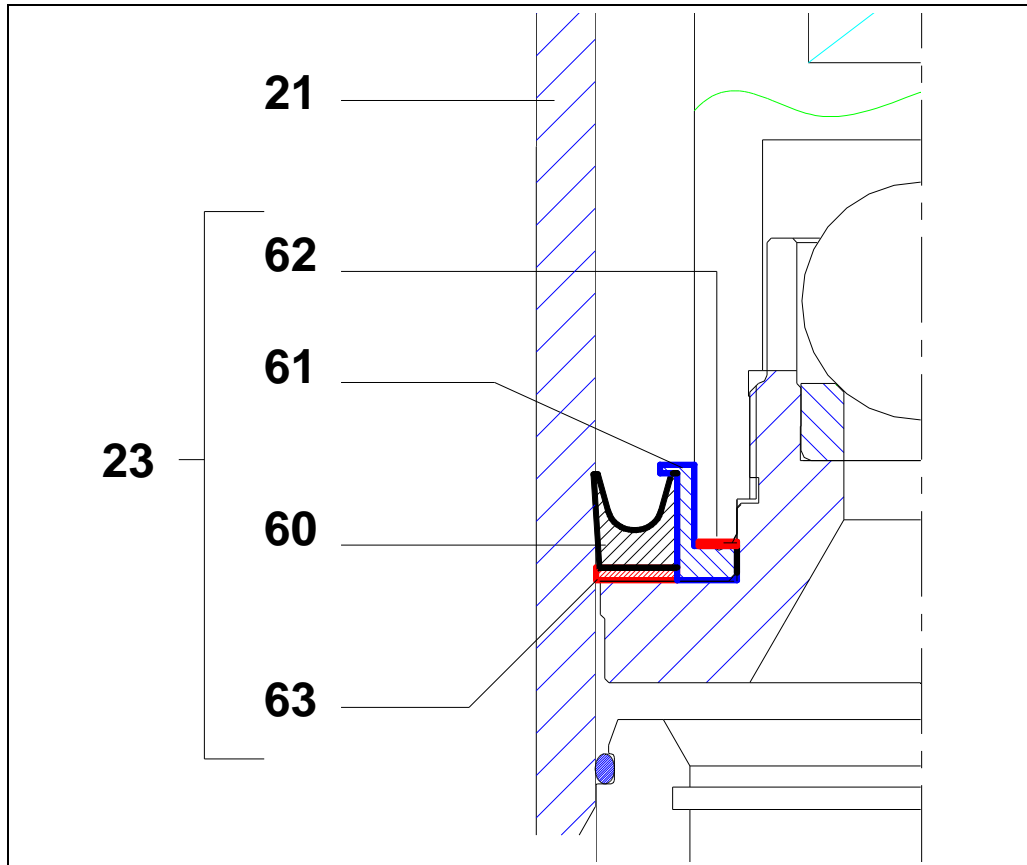

Ind	#	Désignation	Description	Bezeichnung	Denominación	Qté
*	144 970 270	Pochette de joints PU (ind. 11x4, 25, 27, 29, 30, 31, 33, 37, 42, 44, 60, 62, 63)	Package of Polyurethane seals (ind. 11x4, 25, 27, 29, 30, 31, 33, 37, 42, 44, 60, 62, 63)	PU-Dichtungssatz (Pos 11x4,25, 27, 29, 30, 31, 33, 37, 42, 44, 60, 62, 63)	Bolsa de juntas de Poliuretano (ind. 11x4, 25, 27, 29, 30, 31, 33, 37, 42, 44, 60, 62, 63)	1

Doc. 573.403.050 Date/Datum/Fecha : 09/06//11 Annule/Cancel/ Ersetzt/Anula : 11/08/08	Modif. /Änderung : Mise à jour / Update / Aktualisierung / Actualización	Pièces de rechange Spare parts list Ersatzteilliste Piezas de repuesto
---	---	---

EQUIPEMENT D'AIR / AIR SUPPLY / LUFTAUSRÜSTUNG / EQUIPO DE AIRE
Avec 1 détendeur / with 1 air regulator / mit 1 Druckminderer / con 1 manorreductor ,
Mod. 1/2"

➤ **Moteur / Motor, Mod. 1000-4 & 2000-4**

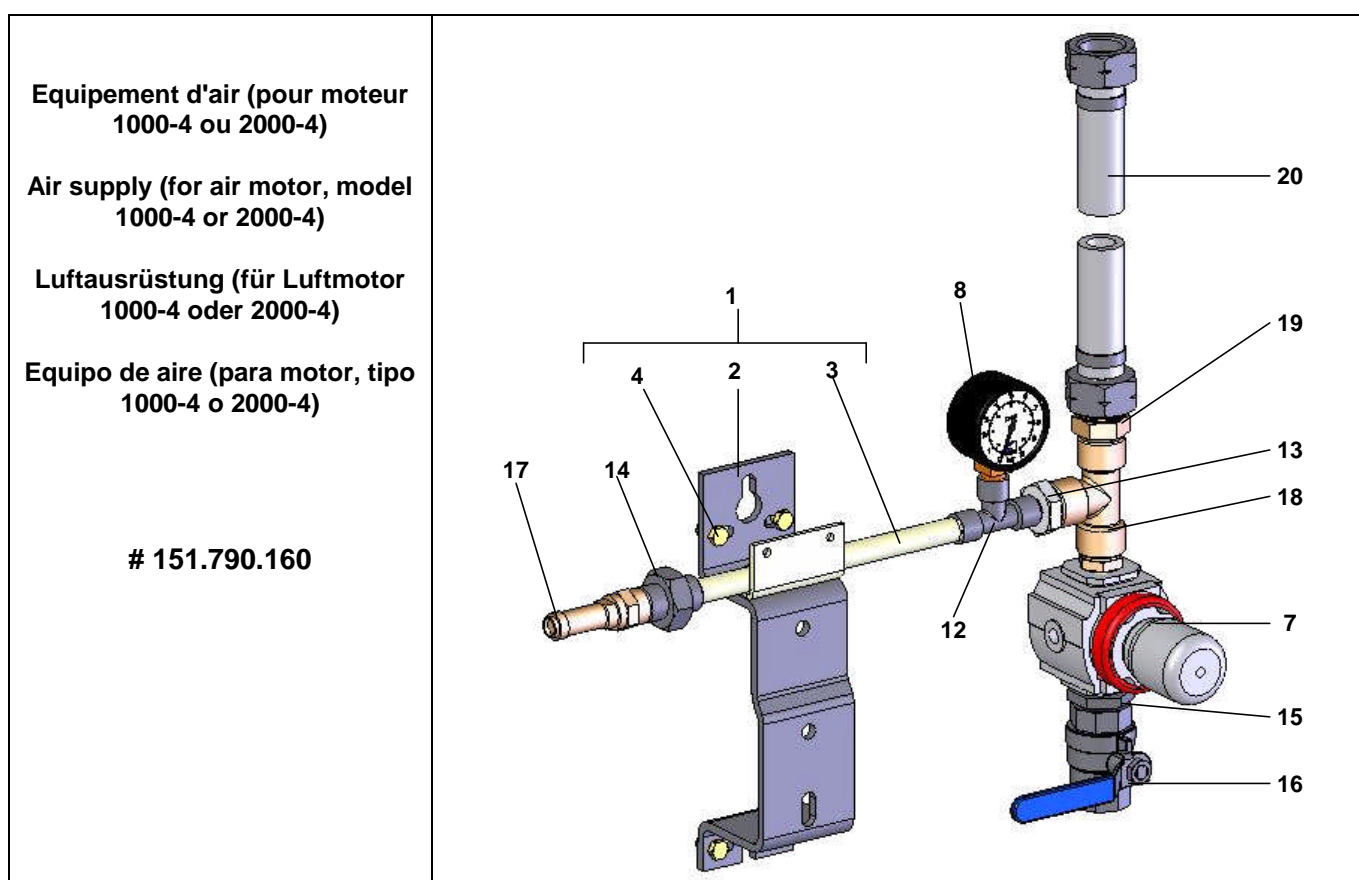

Pièces communes - Common parts - Gleiche Teile - Partes comunes

Ind	#	Désignation	Description	Bezeichnung	Denominación	Qté
1	044.910.121	Support pompe équipé	Pump bracket assembly	Komplette Pumpenhalterung	Soporte de bomba equipado	1
2	044.910.122	▪ Support pompe	▪ Pump bracket	▪ Pumpenhalterung	▪ Soporte de bomba	1
3	051.751.011	▪ Support équipement d'air	▪ Air supply bracket	▪ Luftausrüstungs-halterung	▪ Soporte equipo de aire	1
4	144.910.129	▪ Pochette de 4 vis, 4 écrous, 4 rondelles	▪ Pack of 4 screws, 4 nuts, 4 washers	▪ Satz à 4 Schrauben, 4 Muttern, 4 Scheiben	▪ Bolsa de 4 tornillos, 4 tuercas, 4 arandelas	2
* 7	016.470.000	Détendeur d'air 1/2 – 0-10 bar – (rouge)	Air regulator, 1/2 – 0-10 bar / 0-145 psi – (red)	Druckminderer, 1/2 – 0-10 bar (rot)	Manorreductor, 1/2 – 0-10 bar (rojo)	1

Ind	#	Désignation	Description	Bezeichnung	Denominación	Qté
* 8	910.011.402	Manomètre 0 - 10 bar	Gauge 0 - 10 bar / 0 - 145 psi	Manometer, 0-10 bar	Manómetro, 0-10 bar	1
12	552 436	Té F 1/4"	Tee, F 1/4"	T-Stück , F 1/4"	Te, H 1/4"	1
13	552 475	Raccord M 1/4" – M 1/2"	Fitting, double male, M 1/4" – M 1/2"	Doppelnippel, AG 1/4" – AG 1/2"	Racor, M 1/4" – M 1/2"	1
14	552 486	Manchon 1/4"	Sleeve, 1/4"	Muffe 1/4"	Manguito 1/4"	1
15	552 474	Raccord M 1/2" - M 3/4"	Fitting, double male, 1/2" - 3/4 "	Doppelnippel, AG 1/2 " – AG 3/4 "	Racor, M 1/2 " - M 3/4 "	1
16	903.090.208	Robinet F 3/4 BSP	Valve, F 3/4 BSP	Absperrhahn, F 3/4 BSP	Grifo, H 3/4 BSP	1
17	903.080.401	Soupape de décharge - tarage 6,5 bar	Discharge valve - setting 6,5 bar /94 psi	Sicherheitsventil – eingestellt 6,5 bar	Válvula de seguridad - tarado 6,5 bar	1
18	552 438	Té F 1/2"	Tee, F 1/2"	T-Stück , F 1/2"	Te, H 1/2"	1

Pièces spécifiques - Specific parts - Spezifische Teile - Partes específicas

Ind	#	Désignation	Description	Bezeichnung	Denominación	Qté
19	050.102.401	Raccord M 1/2 BSP - M 3/4 NPS	Adaptor M 1/2 BSP - M 3/4 NPS	Nippel M 1/2 BSP - M 3/4 NPS	Racor M 1/2 BSP - M 3/4 NPS	1
20	050.383.109	Tuyau Ø int. 16 (avec écrous 3/4 NPS)	Hose Ø 16 ID / 3/8 dia. (with nuts, 3/4 NPS)	Schlauch Ø 16 ID (mit Muttern 3/4 NPS)	Tubería Ø int. 16 (con tuercas 3/4 NPS)	1

➤ Moteur / Motor, Mod. 500-4

<p align="center">Equipement d'air (pour moteur 500-4)</p> <p align="center">Air supply (for air motor, model 500-4)</p> <p align="center">Luftausrüstung (für Luftmotor 500-4)</p> <p align="center">Equipo de aire (para motor, tipo 500-4)</p> <p align="center"># 151.790.170</p>	
--	--

Pièces spécifiques - Specific parts - Spezifische Teile - Partes específicas

Ind	#	Désignation	Description	Bezeichnung	Denominación	Qté
19	050.102.633	Raccord M 1/2 BSP - M 1/4 NPS	Adaptor M 1/2 BSP - M 1/4 NPS	Nippel M 1/2 BSP - M 1/4 NPS	Racor M 1/2 BSP - M 1/4 NPS	1
20	539.310.101	Tuyau polyuréthane noir T 8x12 - long. 0,4 m	Hose (black), polyurethane T 8x12 - Length 0.4 m / 15.75 "	Schwarzer Schlauch aus Polyurethan T 8x12 - L. 0,4 m	Tubería poliuretane (negra) T 8x12 - 0,4 m de largo	1
21	050.231.702	Raccord droit avec écrou 1/4 NPS	Straight fitting with nut 1/4 NPS	Gerader Nippel mit Mutter 1/4 NPS	Racor recto con tuerca 1/4 NPS	1

Nota : Pour les références commençant par 5, préciser la longueur à la commande.

Nota : When ordering a spare part whose the first digit is 5, specify the required length.

Hinweis : Bei Artikel-Nummern, die mit einer 5 beginnen, muss die Länge angegeben werden.

Nota : Cuando encarga Vd. una pieza de repuesto que empieza por un 5, precise Vd. la longitud necesaria.

➤ **Moteur / Motor, Mod. 2000-2**

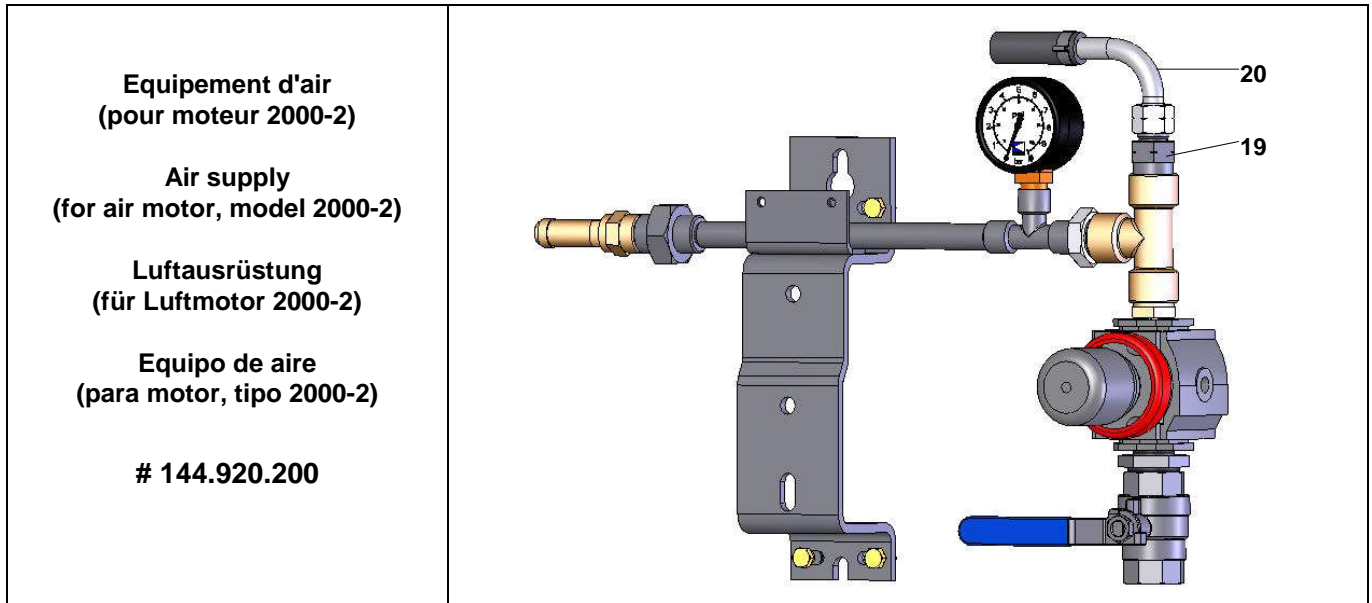

Pièces spécifiques - Specific parts - Spezifische Teile - Partes específicas

Ind	#	Désignation	Description	Bezeichnung	Denominación	Qté
19	050.102.629	Raccord M 1/2 BSP - M 3/8 NPS	Adaptor M 1/2 BSP - M 3/8 NPS	Nippel M 1/2 BSP - M 3/8 NPS	Racor M 1/2 BSP - M 3/8 NPS	1
20	050.381.507	Tuyau Ø int. 10 (avec écrous 3/8 NPS)	Hose Ø 10 ID / 3/8 dia. (with nuts, 3/8 NPS)	Schlauch Ø 10 ID (mit Muttern 3/8 NPS)	Tubería Ø int. 10 (con tuercas 3/8 NPS)	1

➤ **Moteur / Motor, Mod. 1000-4 T & 2000-4 T**

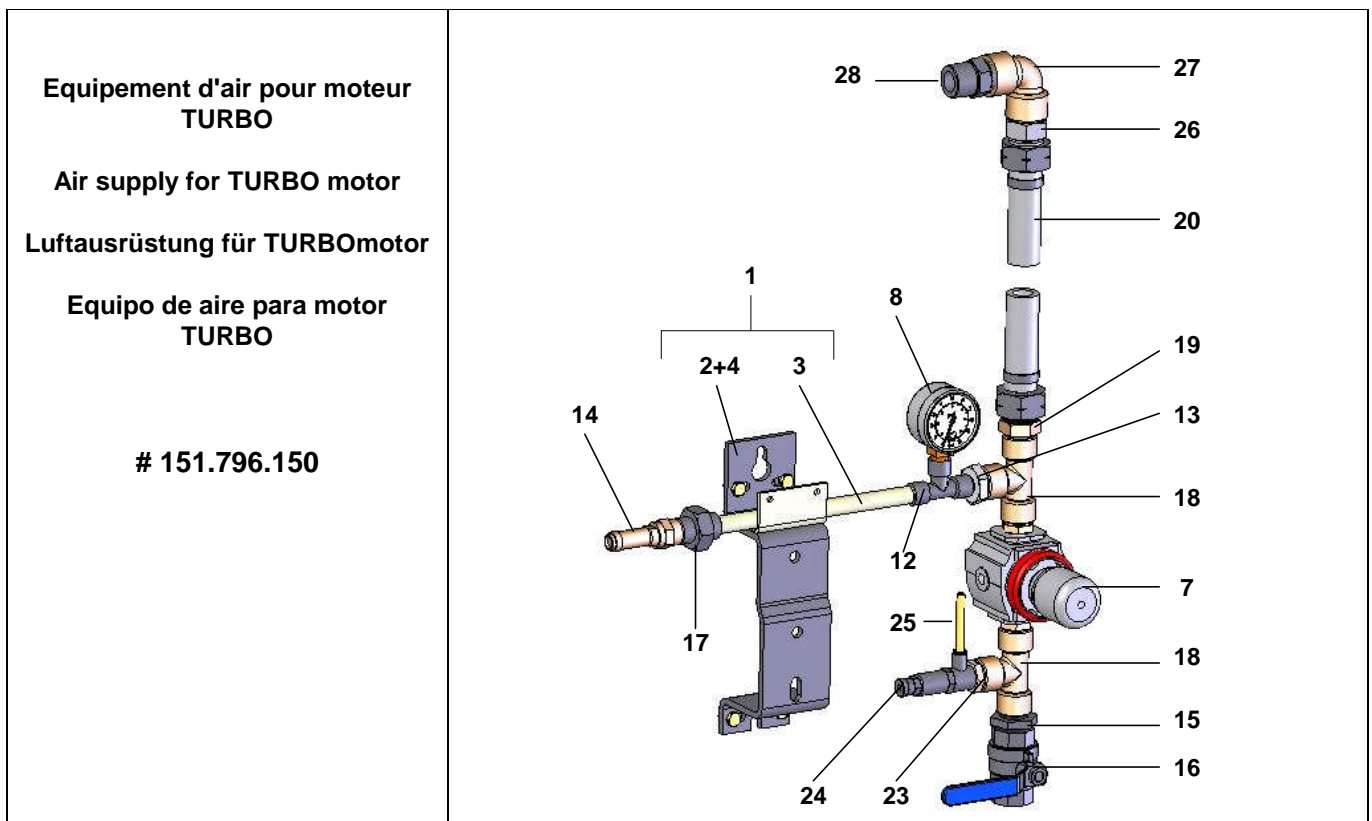

Pièces spécifiques - Specific parts - Spezifische Teile - Partes específicas

Ind	#	Désignation	Description	Bezeichnung	Denominación	Qté
18	552 438	Té FFF 1/2"	Tee, FFF 1/2"	T-Stück , IG 1/2 "	Te, HHH 1/2"	1
19	050.102.401	Raccord M 1/2 BSP - M 3/4 NPS	Adaptor M 1/2 BSP - M 3/4 NPS	Nippel M 1/2 BSP - M 3/4 NPS	Racor M 1/2 BSP - M 3/4 NPS	1
20	050.383.104	Tuyau Ø int. 16 (avec écrous 3/4 NPS)	Hose Ø 16 ID / 3/8 dia. (with nuts, 3/4 NPS)	Schlauch Ø 16 ID (mit Muttern 3/4 NPS)	Tubería Ø int. 16 (con tuercas 3/4 NPS)	1
20	904.653.004	Raccord MM 1/2 BSP	Fitting, double male, 1/2 " BSP	Doppelnippel, AG 1/2 "	Racor, MM 1/2 BSP	1
23	552 411	Réduction M 1/2" - F 1/4"	Adapter M 1/2" - F 1/4"	Reduziernippel AG 1/2" - IG 1/4"	Reducción M 1/2"- H 1/4"	1
* 24	903.130.508	Régulateur de pression	Pressure regulator	Druckventil	Regulator de presión	1
25	539.090.115	Tuyau Ø 4 x 6 - long. 0,5 m	Hose Ø 4 x 6 - length 0,5 m / 20"	Schlauch Ø 4 x 6 - Länge : 0,5 m	Tubería Ø 4 x 6 - 0,5 m de largo	1
26	050.102.634	Raccord M 3/4NPS – M 3/4G	Fitting, double male, 3/4NPS –3/4G	Doppelnippel, AG3/4NPS – AG3/4G	Racor, M 3/4NPS – M 3/4G	1
27	552 429	Coude FF 3/4"	Elbow, FF 3/4"	Winkelnippel, IG 3/4"	Codo, FF 3/4"	1
28	050.102.215	Raccord MM 3/4"	Fitting, double male, 3/4"	Doppelnippel, AG 3/4 " – AG 3/4 "	Racor MM 3/4"	1

Nota : Pour les références commençant par 5, préciser la longueur à la commande.

Nota : When ordering a spare part whose the first digit is 5, specify the required length.

Hinweis : Bei Artikel-Nummern, die mit einer 5 beginnen, muss die Länge angegeben werden.

Nota : Cuando encarga Vd. una pieza de repuesto que empieza por un 5, precise Vd. la longitud necesaria.

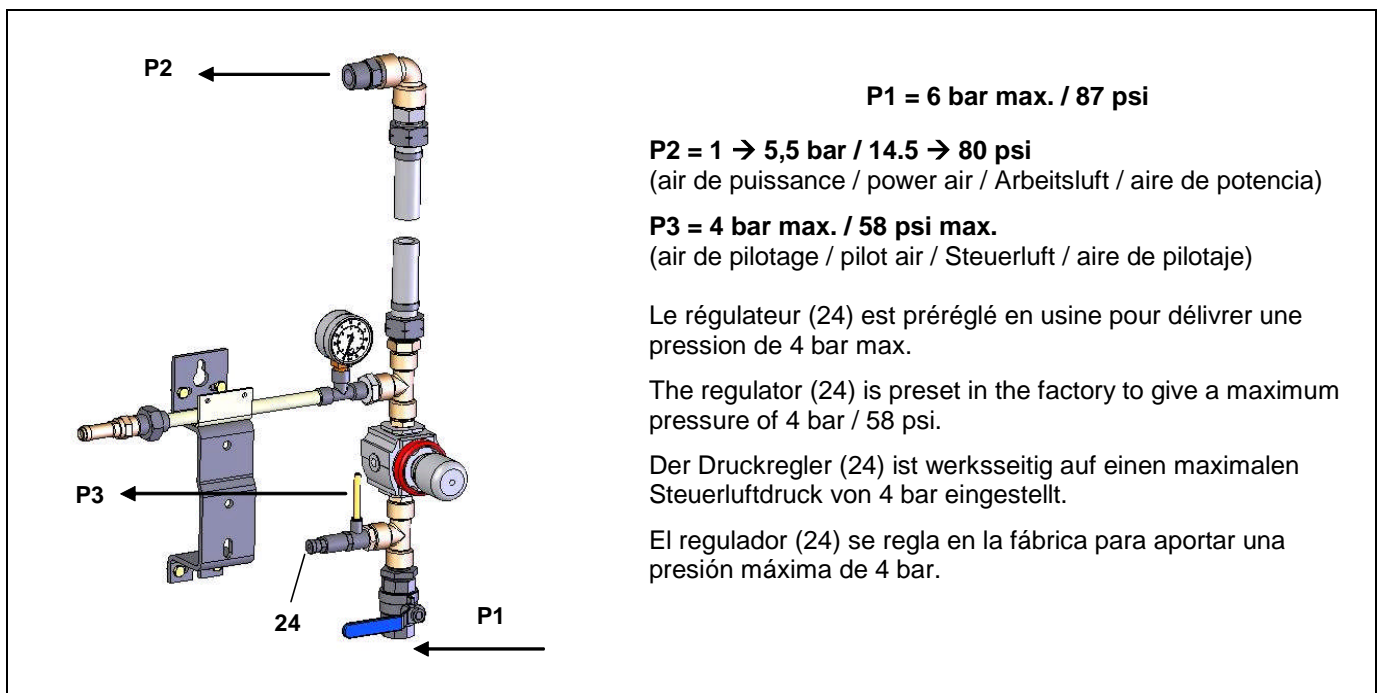

- * Pièces de maintenance préconisées tenues en stock
- * Preceding the index number denotes a suggested spare part.
- * Bezeichnete Teile sind empfohlene Ersatzteile.
- * Piezas de mantenimiento preventivas a tener en stock.

Doc. 573.299.050 Date/Datum/Fecha : 10/06/11 Annule/Cancela/ Ersetzt/Anula : 07/10/04	Modif. /Änderung : Mise à jour / Update / Aktualisierung / Actualización	Pièces de rechange Spare parts list Ersatzteilliste Piezas de repuesto
---	---	---

FILTRE PRODUIT HP, modèle 3/8 inox	HP FLUID FILTER, model 3/8 stainless steel
HP MATERIALFILTER, Modell 3/8 Edelstahl	FILTRO PRODUCTO HP, tipo 3/8 inox

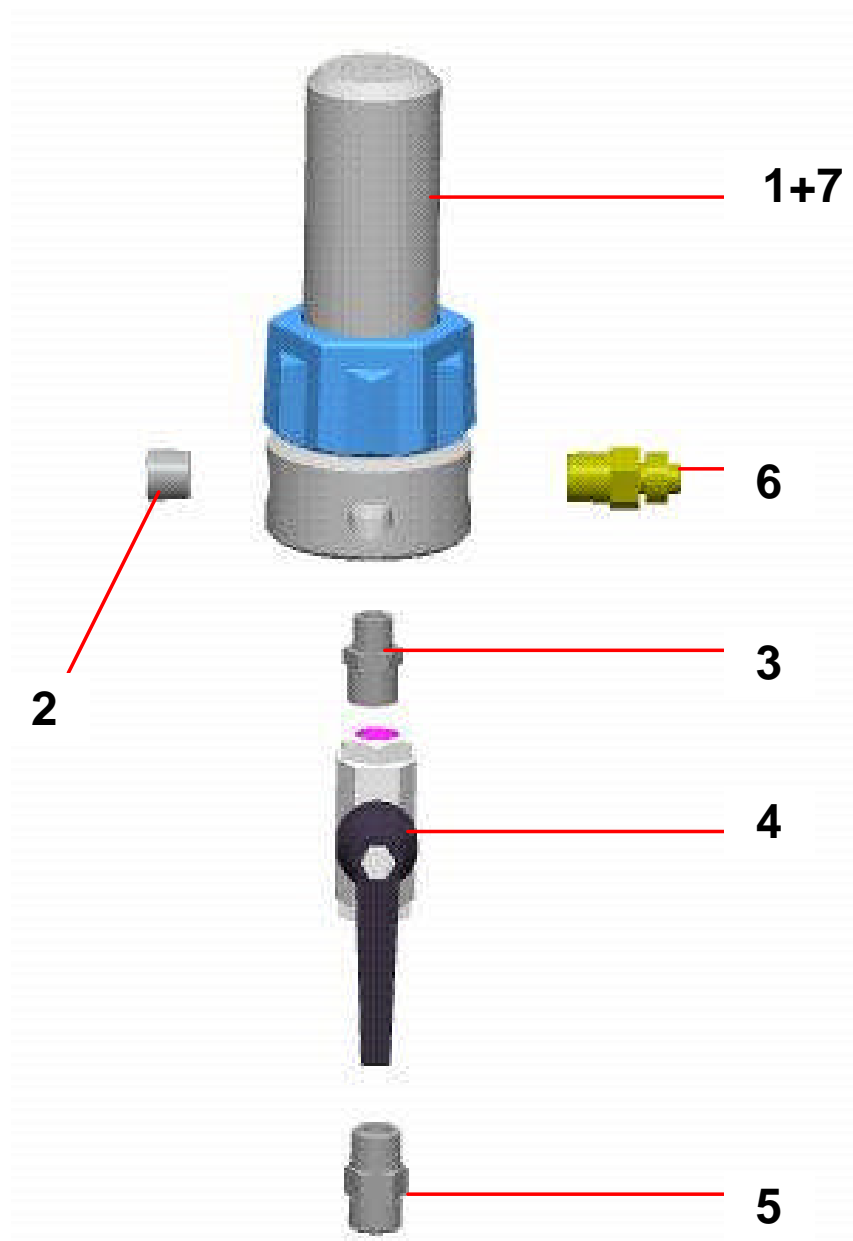

FILTRE EQUIPÉ pour pompes AIRMIX®	FILTRE EQUIPÉ pour pompes AIRLESS®
EQUIPPED FILTER for AIRMIX® pumps	EQUIPPED FILTER for AIRLESS® pumps
AUSGERÜSTETER FILTER für AIRMIX®-Pumpen	AUSGERÜSTETER FILTER für AIRLESS®-Pumpen
FILTRO EQUIPADO para bombas AIRMIX®	FILTRO EQUIPADO para bombas AIRLESS®
# 155.580.300	# 155.580.400

PIECES COMMUNES - COMMON PARTS - GLEICHE TEILE - PARTES COMUNES

Ind	#	Désignation	Description	Bezeichnung	Denominación	Qté
* 1	155.580.200	Filtre nu inox	Bare filter, stainless steel	Nackter Filter - Edelstahl	Filtro solo, inox	1
2	905.210.304	Bouchon inox 3/8 NPT	Plug , stainless steel 3/8 NPT	Blinstopfen - Edelstahl 3/8 NPT	Tapón de inox 3/8 NPT	1
3	906.314.204	Raccord inox M 1/4 - M 3/8	Fitting, double male, 1/4 - 3/8	Doppelnippel AG 1/4 - AG 3/8	Racor inox, M 1/4 - M 3/8	1
* 4	000.750.040	Vanne HP FF 3/8 BSP	HP valve FF 3/8 BSP	Kugelhahn, IG 3/8 BSP	Válvula, HH 3/8 BSP	1
5	050.102.411	Raccord inox M 18 x 125 - M 3/8 BSP	Adaptor, stainless steel, double male 18x125 - 3/8BSP	Doppelnippel - Edelstahl AG 3/8 BSP - M 18x1,25	Racor inox, M 18 x 125 - M 3/8 BSP	1
6	905.210.503	Raccord inox M 3/8 NPT - M 1/2 JIC	Adaptor, stainless steel, double male, 3/8 NPT - # 5 JIC (1/2 JIC)	Doppelnippel Edelstahl 3/8 NPT - 1/2 JIC	Racor, inox M 3/8 NPT - M 1/2 JIC	1

PIECES SPECIFIQUES - SPECIFIC PARTS - SPEZIELLE TEILE - PARTES ESPECIFICAS

⇒ **Filtre / Filter / Filtro # 155.580.300**

Ind	#	Désignation	Description	Bezeichnung	Denominación	Qté
* 7	000.161.106	Tamis n° 6 (168 µ)	Screen n° 6 (168 µ - 85 Mesh)	Filterelement Sieb Nr. 6 (168 µ)	Tamiz n° 6 (168 µ)	1

⇒ **Filtre / Filter / Filtro # 155.580.400**

Ind	#	Désignation	Description	Bezeichnung	Denominación	Qté
* 7	000.161.112	Tamis n° 12 (280 µ)	Screen n° 12 (280 µ - 55 Mesh)	Filterelement Sieb Nr. 12 (280 µ)	Tamiz n° 12 (280 µ)	1

- * Pièces de maintenance préconisées tenues en stock
- * Preceding the index number denotes a suggested spare part.
- * Bezeichnete Teile sind empfohlene Ersatzteile.
- * Piezas de mantenimiento preventivas a tener en stock.

FILTRE NU (sans tamis)	BARE FILTER (without screen)	# 155.580.200
NACKTER FILTER (ohne Sieb)	FILTRO SOLO (sin tamiz)	

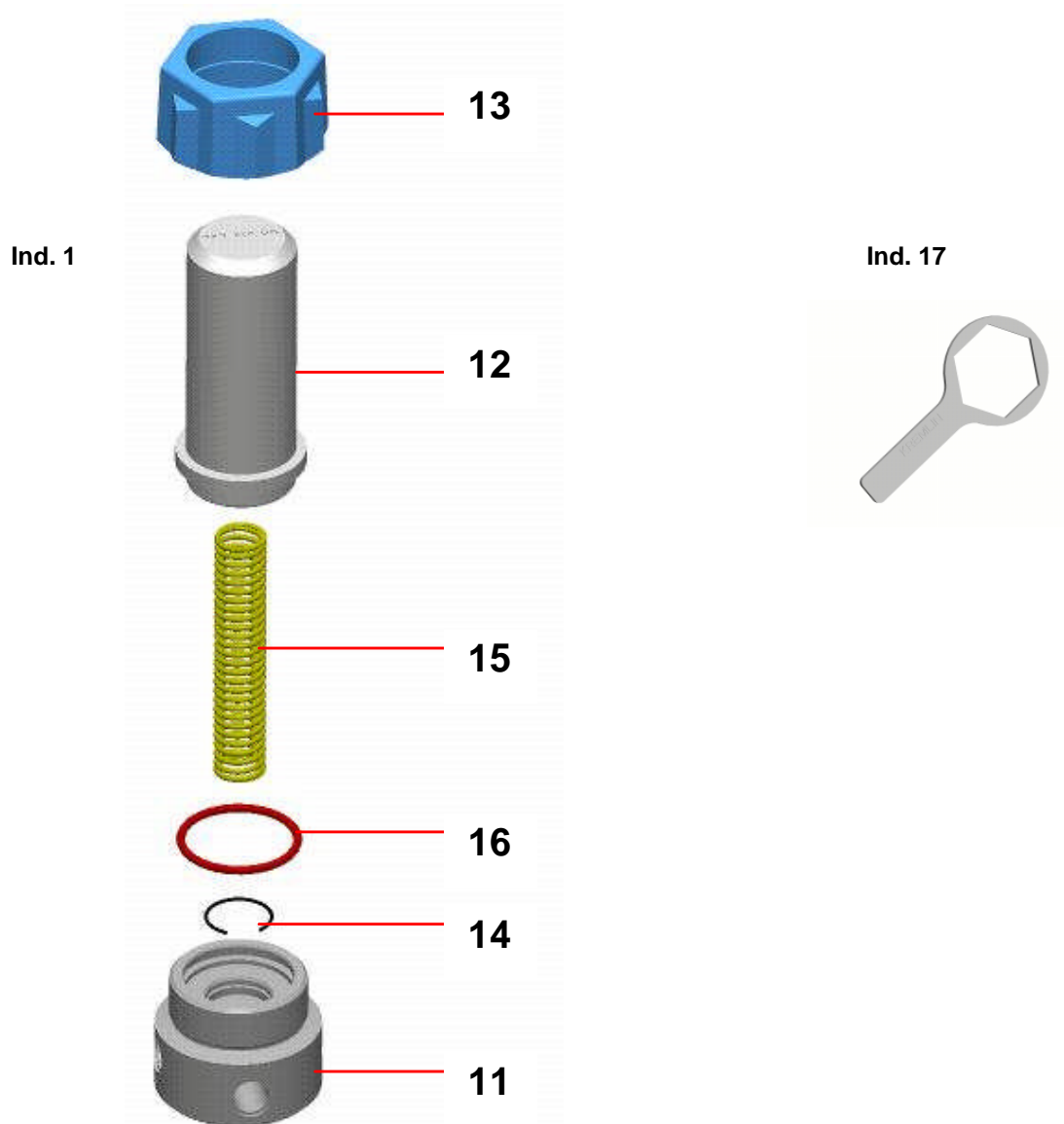

Ind	#	Désignation	Description	Bezeichnung	Denominación	Qté
11	055.580.201	Embase 3/8	Base, model 3/8	Grundblock, Modell 3/8	Base, tipo 3/8	1
12	055.580.202	Cuve	Bowl	Filterglocke	Cubeta	1
13	055.280.002	Ecrou	Nut	Überwurfmutter	Tuerca	1
14	055.190.007	Jonc	Stop ring	Sicherungsring	Clips	1
15	055.190.005	Ressort	Spring	Feder	Muelle	1
* 16	150.040.327	Joint (les 5)	Seal (pack of 5)	Dichtung (5 St.)	Junta (bolsa de 5)	1
17	049.030.018	Clé de démontage	Wrench	Schlüssel	Llave de desmontaje	1

A LA DEMANDE - ON REQUEST - AUF WUNSCH - A PETICIÓN

Ind. 7



Ind	#	Désignation	Description	Bezeichnung	Denominación	Qté
-	000.161.101	Tamis n° 1 (37 µ)	Screen n° 1 (37 µ)	Sieb Nr. 1 (37 µ)	Tamiz n° 1 (37µ)	1
-	000.161.102	Tamis n° 2 (77 µ)	Screen n° 2 (77 µ)	Sieb Nr. 2 (77 µ)	Tamiz n° 2 (77 µ)	1
-	000.161.104	Tamis n° 4 (99 µ)	Screen n° 4 (99 µ)	Sieb Nr. 4 (99 µ)	Tamiz n° 4 (99 µ)	1
7	000.161.106	Tamis n° 6 (168 µ)	Screen n° 6 (168 µ)	Sieb Nr. 6 (168 µ)	Tamiz n° 6 (168 µ)	1
-	000.161.108	Tamis n° 8 (210 µ)	Screen n° 8 (210 µ)	Sieb Nr. 8 (210 µ)	Tamiz n° 8 (210 µ)	1
7	000.161.112	Tamis n° 12 (280 µ)	Screen n° 12 (280 µ)	Sieb Nr. 12 (280 µ)	Tamiz n° 12 (280 µ)	1
-	000.161.115	Tamis n° 15 (360 µ)	Screen n° 15 (360 µ)	Sieb Nr. 15 (360 µ)	Tamiz n° 15 (360 µ)	1
-	000.161.020	Tamis n° 20 (510 µ)	Screen n° 20 (510 µ)	Sieb Nr. 20 (510 µ)	Tamiz n° 20 (510 µ)	1
-	000.161.030	Tamis n° 30 (750 µ)	Screen n° 30 (750 µ)	Sieb Nr. 30 (750 µ)	Tamiz n° 30 (750 µ)	1

OPTIONS - ON REQUEST - OPTIONEN - OPCIONES

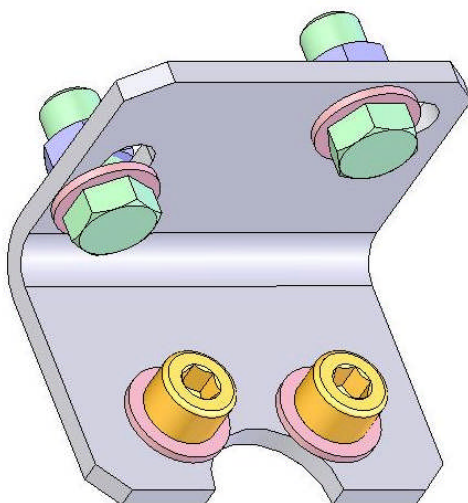

Ind	#	Désignation	Description	Bezeichnung	Denominación	Qté
-	155.190.105	Support filtre avec vis, rondelles et écrous	Mounting bracket with screws, washers and nuts	Filterhalterung mit Schrauben, Scheiben und Muttern	Soporte filtro con tornillos, arandelas y tuercas	1



**AIRMIX ® PUMP and
LOW-PRESSURE PUMP
air motor with reversing block
*PREVENTIVE MAINTENANCE***

TRANSLATION OF THE ORIGINAL MANUAL

IMPORTANT : Before assembly and start-up, please read and clearly understand all the documents relating to this equipment (professional use only).

THE PICTURES AND DRAWINGS ARE NON CONTRACTUAL. WE RESERVE THE RIGHT TO MAKE CHANGES WITHOUT PRIOR NOTICE.

KREMLIN - REXSON

150, avenue de Stalingrad

93 245 - STAINS CEDEX – France

☎ : 33 (0)1 49 40 25 25 *Fax* : 33 (0)1 48 26 07 16

www.kremlin-rexson.com

■ PUMP

Make sure that the pump is clean and in good condition to increase equipment working life.

If the pump is an intensive™ one :

- Regularly clean the wetting-cup with "T" lubricant (this "T" lubricant will normally be coloured by the paint).
- Regularly clean the wetting-cup with solvent after having drained the lubricant (unscrew the plug on the upper flange).

**Guards (air motor cover, coupling shields, housings,...) have been designed for safe use of the equipment.
The manufacturer will not be held responsible for bodily injury or failure and / or damage to property due to removal or partial removal of the guards.**

Make sure that the suction strainer is clean and in good condition. Regularly clean it and change it if necessary.

Flush the pump as often as necessary, specially when spraying pigment-filled material.

**Whatever the case, when stopping the pump, always leave it filled with material.
For a short duration shutdown, if the flushing has not been carried out, leave the pump filled with material.
For a short duration shutdown, after flushing the pump, leave it filled with solvent.**

■ SPRAY GUN

Comply with the usual instructions of spray gun servicing (refer to spary gun instruction manual).

■ FILTER

If the pump is mounted with a filter at the fluid outlet, comply with the usual instructions of filter servicing (refer to filter instruction manual)



AIRMIX ® PUMP and LOW-PRESSURE PUMP air motor with reversing block

TROUBLESHOOTING

TRANSLATION OF THE ORIGINAL MANUAL

IMPORTANT : Before assembly and start-up, please read and clearly understand all the documents relating to this equipment (professional use only).

THE PICTURES AND DRAWINGS ARE NON CONTRACTUAL. WE RESERVE THE RIGHT TO MAKE CHANGES WITHOUT PRIOR NOTICE.

KREMLIN - REXSON

150, avenue de Stalingrad

93 245 - STAINS CEDEX – France

☎ : 33 (0)1 49 40 25 25 *Fax* : 33 (0)1 48 26 07 16

www.kremlin-rexson.com

CAUSE	SOLUTION
The pump does not start.	Check the pump air supply.
Priming trouble : → Air is always coming out from the spray gun. → Air (or material) does not come out from the spray gun.	Be sure that the spray gun is fully opened and air evacuated through this one. Air intake at the fitting or at the suction rod. Check the pump valves. If a valve is stucked by dry paint, it can be unsticked without disassembling it. Blow air pressure directly by suction fitting.
The pump does not stop at once when shutting off the spray gun : → The pump stops only on down stroke. → The pump stops only on up stroke.	Check exhaust valve or valve seal. Check suction valve or upper cartridge.
The pump does not reverse.	Check spring of the air motor reversing block. Lubricate reversing-block with HP 150 oil. Check is there is pilot air (depending on air motor model).
On intensive™ pump, the lubricant into the cup is fastly coloured.	Check the upper packing (tighten the cup or change seals if it is necessary).
On FLOWMAX ® pump, leakage of fluid at the bottom of the air motor.	Check bellow.
Spraying trouble.	Refer to spray gun instruction manual.
Decrease of material flow.	Refer to filter instruction manual.



**AIRMIX ® PUMP and
LOW-PRESSURE PUMP
air motor with reversing block
*OPERATING PRINCIPLE AND START-UP***

TRANSLATION OF THE ORIGINAL MANUAL

IMPORTANT : Before assembly and start-up, please read and clearly understand all the documents relating to this equipment (professional use only).

THE PICTURES AND DRAWINGS ARE NON CONTRACTUAL. WE RESERVE THE RIGHT TO MAKE CHANGES WITHOUT PRIOR NOTICE.

KREMLIN - REXSON

150, avenue de Stalingrad

93 245 - STAINS CEDEX – France

☎ : 33 (0)1 49 40 25 25 Fax : 33 (0)1 48 26 07 16

www.kremlin-rexson.com

FLOWMAX ® PUMP

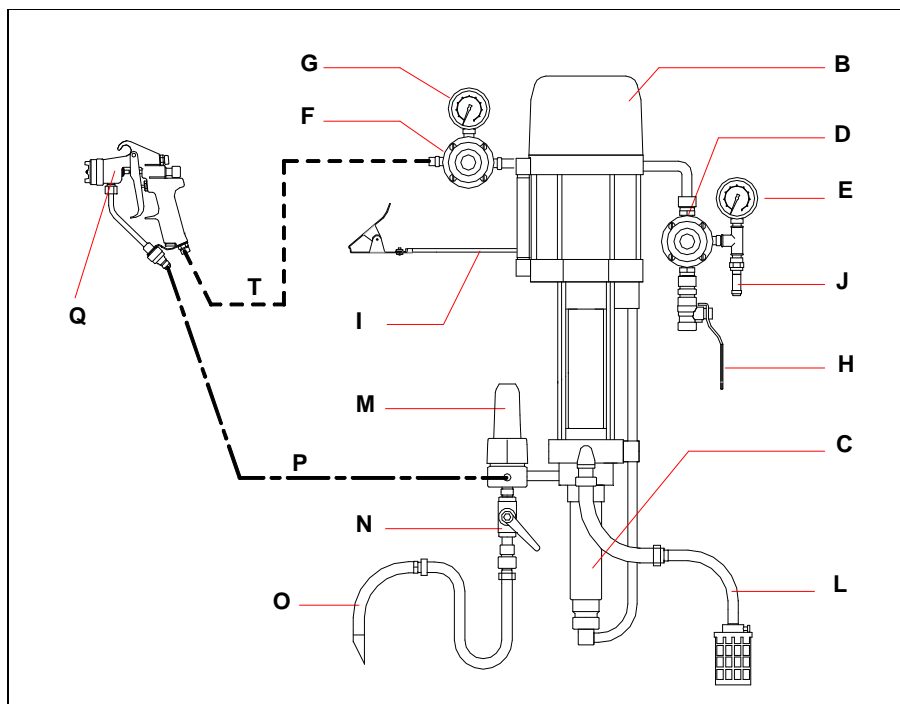

Captions :

A	Intensive™ or FLOWMAX ® pump (B + C)	L	Suction rod (depending on version)
B	Air motor	M	Accumulator filter (depending on version)
C	Fluid section	N	Drain valve (depending on version)
D	Air regulator "MOTOR AIR"	O	Drain rod (depending on version)
E	Gauge	P	HP Fluid hose
F	Air regulator "GUN AIR" (depending on version)	Q	Spray gun
G	Gauge (depending on version)	R	"T" lubricant (1/4 l / 0.07 US gal) (only for intensive™ pump)
H	Air inlet valve	S	Wetting-cup (only for intensive™ pump)
I	Ground	T	Air hose (static conductor)
J	Discharge valve		

(For specific installation, please contact your KREMLIN REXSON representative).

Nota : If the pump is equipped with an accumulator filter (M), the filter is supplied with a stainless steel screen n° 6 (filtration size : 168 microns or 85 mesh). The screen is recommended for the use of an AIRMIX gun fitted with a nozzle model n° 6. If the fluid spraying is carried out by means of an other nozzle, choose an other screen (refer to the filter instruction manual). Adjust the screen to the application.

Start up procedure :

- 1 - Ground the pump.
- 2 - **If the pump is a intensive™ one, fill up the wetting-cup (S) with "T" lubricant (R) or with an appropriate solvent.**
- 3 - Unscrew the air regulators (D and F).
- 4 - Interconnect the air equipment with the air pressure network (clean air - Pressure < 6 bar / 87 psi). Install a water drop, model 3/4" (or model 3/8" if the pump is equipped with an air motor, model 500/4), if it is necessary.
- 5 - Connect all the hoses, air hose and fluid hose (P), as well as the spray gun (Q).
Nota : Comply with the diameters of hoses recommended in the specifications of the pump.
- 6 - Remove the nozzle from the spray gun.

■ **FLUSHING WITH SOLVENT**

- 7 - Immerse suction rod (L) and the drain rod (O) into the material container.
- 8 - Open the air shut off valve (N).
- 9 - Open the valve (H) of the pump air equipment to supply the air motor.

Nota : If the pump air motor is a 5000 version, it needs pilot air to operate. The pump air equipment supplies pilot air to the air motor. The air supply pressure is adjusted previously in the factory to 4 bars / 58 psi maximum.

- 10 - Increase **progressively** the air regulator (D) so that the pump runs slowly (Pressure between 0,5 to 1 bar / 7.25 to 14.503 psi).
- 11 - Observe the drain (O); air bubbles come out from it. When bubbles no longer come out from it, shut off the drain valve (N).

■ **PRIMING WITH MATERIAL**

- 12 - Remove the suction rod (L) and the drain rod (O) from the material container and immerse them in a solvent filled container.
- 13 - Open the drain valve (N), wait until the material flows out regularly, then shut off the drain valve (N).
- 14 - Point the spray gun towards the material container and trigger the spray gun until the material flows out regularly.

■ **WORK**

- 15 - Reinstall the ring and the aircap on the spray gun.
- 16 - Adjust air regulator (D) to obtain the appropriate material pressure and flow rate.
- 17 - **Gradually** open the air regulator (F) to adjust the spraying air to obtain the required spray pattern.

Nota : Some of these pumps are not equipped in the intensiv™ version with the air regulator (F).

A spraying air kit can be mounted on the pump air equipment in order to supply compressed air to the spray gun if it is necessary.

2-2 PUMP SUPPLIED IN FILLING (CIRCULATING)

Interconnect the pump fluid inlet with the circulating supply hose and start up the pump as it is specified previously.

If the pump is a FLOWMAX® one :

WARNING:

- **Fluid section filling pressure** : 2 bar / 29 psi maximum
- **WARNING : Do not create overpressure**
- **NEVER use** the pump when **an isolating gate on the supply circuit** (upstream from the FLOWMAX® fluid section) is shut : **it would damage the bellows.**
- **Do not install** a material regulator on the supply circuit or any arrangement that could perform as a non-return valve.

3. SHUTDOWN AT THE END OF THE WORK

▪ SHORT DURATION SHUTDOWN

- 1 - Decrease the material pressure of air regulator (D) until reading **0 bar / 0 psi** on the gauge (E).
- 2 - Trigger the spray gun to depressurize the system.
- 3 - Unscrew the spray gun air regulator (F) or disconnect the spray gun air inlet.
- 4 - Remove the aircap from the spray gun, (aircap and nozzle for Airmix ® spray gun) and soak it into solvent.

▪ LONG DURATION SHUTDOWN

- 1 - Decrease the air regulator (D) until reading **1 bar / 14.503 psi** on gauge (E).
- 2 - Unscrew the spray gun air regulator (F) or disconnect the spray gun air inlet.
- 3 - Remove the spray gun aircap, (aircap and nozzle for AIRMIX ® spray gun) and soak it into solvent.
- 4 - Open the drain valve. The pump must operate slowly. If the speed is too high, decrease the air regulator (D) pressure.
- 5 - Remove the suction rod and the drain rod from the material container and immerse them in a solvent-filled container. Take all the appropriate precautions in the presence of flammable solvents.
- 6 - When the solvent flows out regularly, close the drain valve.
- 7 - Point the spray gun towards the material container and press the gun trigger. When the solvent flows out, point the spray gun towards the recovery container.
- 8 - When the solvent flows out, release the spray gun trigger.
Nota : If the pump is a intensive™ one, release the spray gun trigger when the pump is in a low position. To prevent from damaging the seals when starting the pump, the piston must be immersed into solvent.
- 9 - Fully unscrew the air regulator (D) and shut off the main compressed air valve (valve H).
- 10 - Press the spray gun trigger to decompress the hoses. Therefore, the pump and the hose remain filled with solvent at the atmospheric pressure

4. SAFETY DEVICE

Guards (air motor cover, coupling shields, housings ...) have been designed for safe use of the equipment.

The manufacturer will not be held responsible for bodily injury or failure and / or damage to property due to removal or partial removal of the guards

A relief-valve (setting : 6,5 bar / 94 psi) is fitted on the pump air motor - thus protecting this one from an overpressure which could damage it.



FLOWMAX® PUMP

04-120 F

TECHNICAL FEATURES

TRANSLATION FROM THE ORIGINAL MANUAL

IMPORTANT : Before assembly and start-up, please read and clearly understand all the documents relating to this equipment (professional use only).

THE PICTURES AND DRAWINGS ARE NON CONTRACTUAL. WE RESERVE THE RIGHT TO MAKE CHANGES WITHOUT PRIOR NOTICE.

KREMLIN - REXSON

150, avenue de Stalingrad
93 245 - STAINS CEDEX - France

☎ : 33 (0)1 49 40 25 25 *Fax* : 33 (0)1 48 26 07 16

www.kremlin-rexson.com

1. DESCRIPTION

- Air operated piston pump with a bellows seal fluid packing
- Low maintenance and ease of use. Use without lubrication

Designed for :

- Supplying one or several spray guns
- Water-based or solvent-based paints
- Circulating

2. TECHNICAL FEATURES

Motor model 500-4
 Body pump model FLOWMAX 120 F
 Theoretical pressure ratio 04/1
 Weight (bare wall mounted pump) 27 kg / 59.5 Lbs

Wetted parts :

Hard chrome stainless steel
 Stainless steel, carbide

Tightness packings :

Bellows : polyethylene
 Upper fixed : GT seal (polyethylene)
 Lower, mobile : polyethylene

Air motor stroke	100 mm	4"
Air motor section	50 cm ²	7.75 sq.in
Fluid section	12 cm ²	1.9 sq.in
Delivery per cycle	240 cm ³	8.5 oz
Number of cycles	4 per liter	16 per gal
Flow (30 cycles)	7.2 l	1.9 US gal
Maximum air operating pressure	6 bar	87 psi
Maximum discharge pressure	24 bar	348 psi
Weighted sound pressure (LAeq)	74 dBa	74 dBa
Maximum operating temperature	50° C	122° F

* Test conditions - Noise level :

- Test duration : 30 s,
- Motor air pressure : 6 bar,
- Material used : water,
- Flow rate : Pump adjusted at 20 cycles/minute

■ FITTINGS

		Bare pump	Pump with equipment
Air	Inlet	Female 1/4" BSP	Female 3/4" BSP (valve - air supply)
Material	Inlet	Female 1/2" BSP	Male 26x125 + suction rod (fitting F 26 x 125)
	Outlet	Female 1/2" NPS	Male 3/8 NPS (filter outlet + fitting)

■ HOSES WITH FITTINGS

Pump air supply hose (minimum Ø for a 5m / 16.5 ft length) : 10 mm ID / 3/8 dia
 Fluid hose (between pump fluid outlet and spray gun) : minimum 7 mm ID / 1/4 dia
 Air hose (between "GUN AIR" regulator and spray gun) : 7 mm ID / 1/4 dia
 For circulating : HP fluid hose (pump fluid outlet) : minimum ID 9,52 mm / 3/8" dia

■ DIMENSIONS

Ind.	mm	"	Ind.	mm	"	Ind.	mm	"	Ind.	mm	"
A	400	15.75	B	160	6.29	C	1,040	40.94	D	210	8.27
E	182	7.2	F	35	1.38	G	36.5	1.43	H	60	2.36
I	211.5	8.3	J	Ø 7 x 15	Ø 0.27 x 0.6	K	Ø 17	Ø 0.67	L	Ø 9	Ø 0.35
M	Ø 9	Ø 0.35									

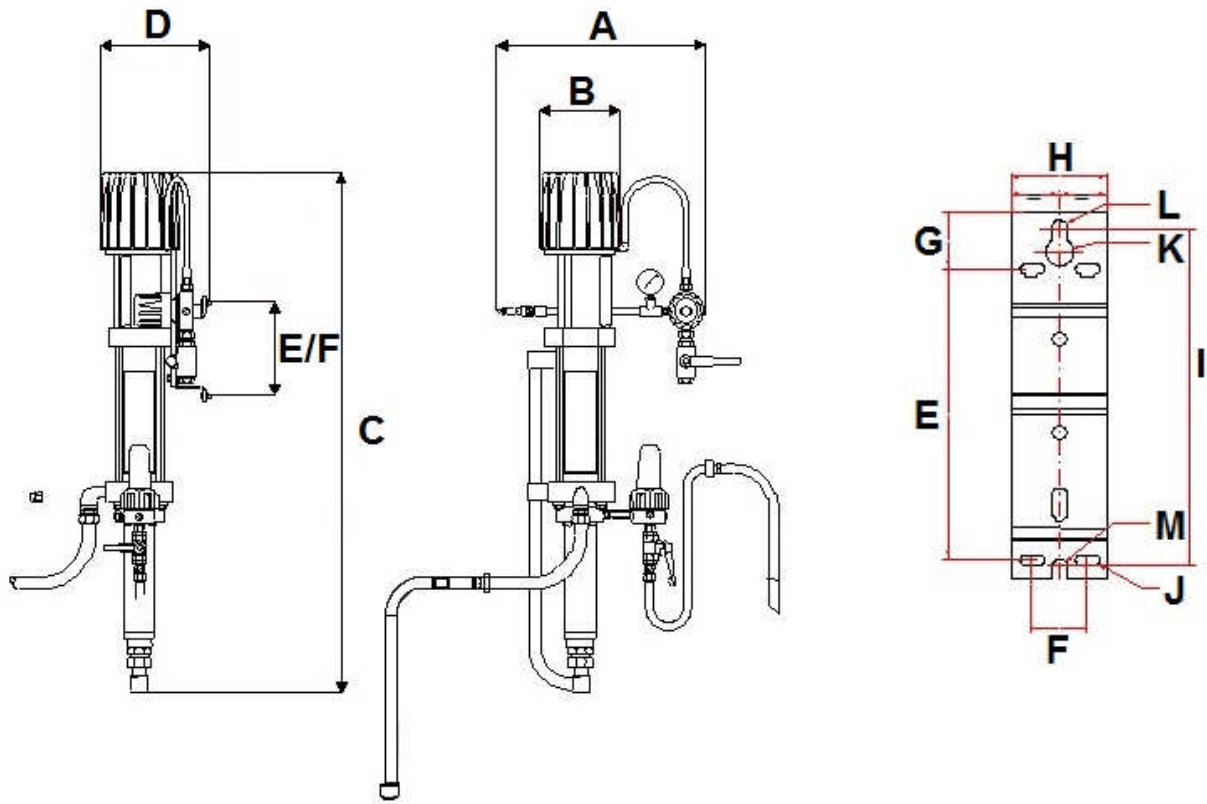



3. INSTALLATION

The pumps are designed to be installed in a spray booth.

■ DESCRIPTION OF THE LABEL MARKING

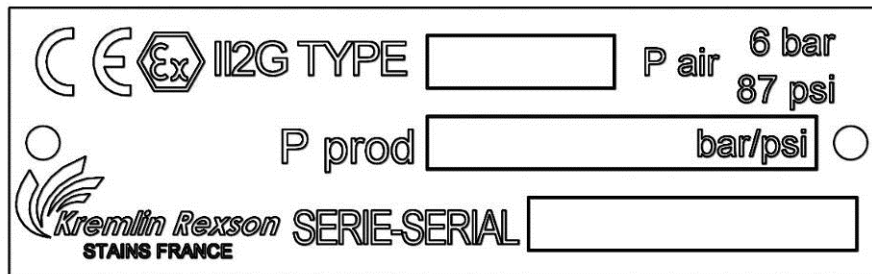
Marking in accordance with the ATEX Directive



KREMLIN REXSON STAINS FRANCE	Name and address of the manufacturer
TYPE xx	Pump model
 II 2 G	II : group II 2 : class 2 Surface equipment meant to area where explosive atmospheres due to gas, vapours, mists are liable to appear from time to time in usual operating G : gas
P prod : xx bar / xx psi	Maximum fluid pressure at the pump outlet
P air : 6 bar / 87 psi	Air supply maximum pressure of the pump motor
Serie / Serial	Number given by KREMLIN REXSON. The two first numbers indicate the manufacturing year.

■ INSTALLATION INSTRUCTIONS

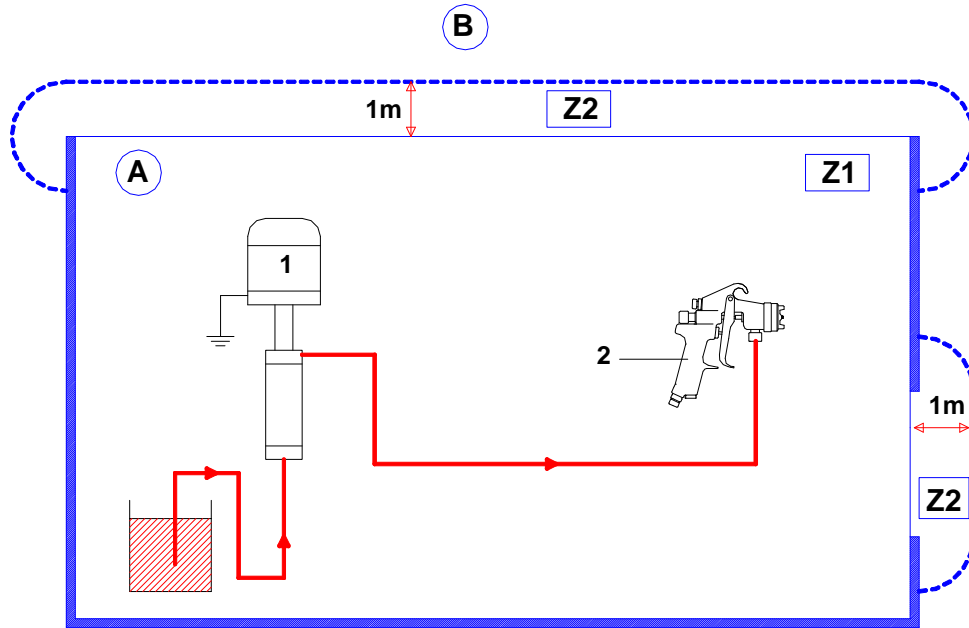

Ind.	Description
A	Explosive area area 1 (Z1) or area 2 (Z2) : spray booth
B	Non explosive area

Ind.	Description
1	Pump
2	Spray gun



The 1 m / 39.37" distance indicated in these diagrams is given for information purposes only and hold harmless to KREMLIN REXSON. The user is responsible for the extraction and conditioning of the painting area where the equipment is used, for working conditions conditions (refer to EN 60079-10 standard). The 1 m / 39.37" distance may be modified if trials carried out by the user deem this necessary.



NB: Choose the appropriate pump to ensure that the working pressure supplied is suitable for the selected gun.