



From February 1st, 2017 SAMES Technologies SAS becomes SAMES KREMLIN SAS
A partir du 1/02/17, SAMES Technologies SAS devient SAMES KREMLIN SAS



User manual

PPH 707 ICWB M Atomizer

SAS SAMES Technologies. 13 Chemin de Malacher -
Inovallée - CS 70086 - 38243 Meylan Cedex
Tel. 33 (0)4 76 41 60 60 - Fax. 33 (0)4 76 41 60 90 - www.sames.com

All communication or reproduction of this document, in any form whatsoever and all use or communication of its contents are forbidden without express written authorisation from SAMES Technologies.

The descriptions and characteristics mentioned in this document are subject to change without prior notice.

© SAMES Technologies 2011



WARNING : SAS Sames Technologies is registered with the Ministry of Labour as a training institution.

Throughout the year, our company offers training courses in the operation and maintenance of your equipment.

A catalogue is available on request. Choose from a wide range of courses to acquire the skills or knowledge that is required to match your production requirements and objectives.

Our training courses can be delivered at your site or in the training centre at our Meylan head office.

Training department:

Tel. 33 (0)4 76 41 60 04

E-mail: formation-client@sames.com

SAS Sames Technologies operating manuals are written in French and translated into English, German, Spanish, Italian and Portuguese.

The French version is deemed the official text and Sames will not be liable for the translations into other languages.

PPH 707 ICWB M

Atomizer

1. Health and Safety Instructions - - - - -	5
1.1. Configuration of certified equipment	5
1.2. Marking on atomizer	5
1.3. Precautions for use	6
1.4. Warnings	6
1.4.1. Installation Rules	9
1.5. Important Recommendations	10
1.5.1. Compressed air quality	10
1.5.2. Product quality	10
1.5.3. Bearing safety	10
1.5.4. Locking.	10
1.5.5. Shaping air.	11
1.5.6. High voltage.	11
1.5.7. Maximum speed.	11
1.5.8. Vibrations.	11
1.5.9. Ventilation	11
1.5.10. O-ring seals	11
1.5.11. Residual pressure	11
1.5.12. Safety devices	12
1.5.13. Mechanical collision.	12
1.5.14. Ambient temperature	12
1.5.15. Sound level	12
1.5.16. Special maintenance measures.	12
1.6. Guarantee	13
2. Description - - - - -	14
2.1. General	14
2.2. Function of the parts	15
3. Technical characteristics - - - - -	16
3.1. Dimensions (mm)	16
3.2. Operating characteristics	17
3.3. Operating principle	18
3.3.1. Turbine.	18
3.3.2. Rotation speed measurement	18
4. Fluid diagram - - - - -	19
5. Startup - - - - -	21
5.1. Tools	21
5.2. Installation	24
5.3. Shutdown and startup procedures	25
5.3.1. Shutdown procedure	25
5.3.2. Start-up Procedure.	25
6. Maintenance - - - - -	26
6.1. Summary table of maintenance operations	26

6.2. Preventive maintenance	27
6.2.1. Procedure A: Atomizer exterior	27
6.2.2. Procedure B1: Magnetic bell cup	28
6.2.3. Procedure B2: Shaping air assembly	29
6.2.4. Procedure B3: Injector exterior	30
6.2.5. Procedure C1: Turbine	31
6.2.6. Procedure C2: Injector / Injector holder	32
6.2.7. Procedure C3: ports from optical fiber system	32
6.3. Corrective maintenance	33
6.3.1. Procedure D1: Body installation/removal	33
6.3.2. Procedure D2: Replacement of body o-rings	33
6.3.3. Procedure D3: Replacement of solvent pipette	33
6.3.4. Procedure D4: Replacement of nanovalves	34
6.3.5. Procedure D5: Replacement of microvalves	34
6.3.6. Procedure D6: Replacement of high-speed turbine	34
6.3.7. Procedure D7: Replacing optical fiber	35
6.3.8. Procedure E1: Hose replacement	36
6.3.9. Procedure E2: Replacement of fittings	37
6.3.10. Procedure E3: Replacement of high voltage connection	38
6.3.11. Procedure E4: Replacement of quick-disconnect plate	40
7. Spare parts list - - - - -	41
7.1. PPH 707 ICWB M body assembly	43
7.1.1. PPH 707 ICWB M body	44
7.1.2. PPH 707 ICWB M body with optical fiber	47
7.1.3. Injector / injector holder assembly	48
7.2. Quick-disconnect plate assembly	49
7.3. High voltage connection	50
7.4. PPH 707 ICWB M support assembly	51

1. Health and Safety Instructions

This manual contains links to the following user manuals:

- [see RT Nr 7070](#) for the user manual of the bell cups, Hi-TE Technologies.
- [see RT Nr 6354](#) for the user manual of the high-speed turbine.
- [see RT Nr 6258](#) for the user manual of the nanovalve.
- [see RT Nr 6021](#) for the user manual of the microvalve.
- [see RT Nr 6190](#) for the user manual of the microphone.
- [see RT Nr 7027](#) for the user manual of the high voltage unit UHT 288 EEx e.
- [see RT Nr 6213](#) for the user manual of the control module GNM 200.
- [see RT Nr 6364](#) for the user manual of electrical systems.

1.1. Configuration of certified equipment

These user manuals define the configuration of certified equipment.

1.2. Marking on atomizer

SAMES Meylan France

CE 0080

PPH 707

P/N : *

ISSeP06ATEX032X**



II 2 G

EEx > 350mJ

(Serial no.)

* ATEX PPH 707 configurations

Atomizer - P/N 910009002 Body - P/N 910005623 Nanovalve - P/N 1510004 Microvalve - P/N 1507375 Turbine - P/N 1525849	Atomizer with optical fiber - P/N 910009002FO Body with optical fiber - P/N 910005623 Nanovalve - P/N 1510004 Microvalve - P/N 1507375 Turbine - P/N 1525849	P/N PPH 707 (*)	High Voltage Unit UHT 288 EEx e P/N 910002864	GNM 200A P/N 1517071
X		910009002	X	X
	X	910009002FO	X	X

** The sign "X" signifies that respecting the safety distance (between the parts of the atomizer that are under high voltage and the grounded parts) mentioned in this user's manual, ensures a safe use of the equipment.

1.3. Precautions for use

This document contains information that all operators should be aware of before using atomizer PPH 707 ICWB M. This information includes indications of situations potentially resulting in severe damage and of the preventive precautions to be taken.



WARNING : Before any use of the PPH 707 ICWB M equipment, check that all operators:

- have previously be trained by the compagny Sames Technologies, or by their distributors registered by them for this purpose.
- have read and understood the user manual and all rules for installation and operation, as laid out below.

It is the responsibility of the operators' workshop manager to ensure these two points and it is also his responsibility to make sure that all operators have read and understood the user manuals for any peripheral electrical equipment present in the spraying area.

1.4. Warnings



WARNING : This equipment may be dangerous if it is not used, disassembled and reassembled in compliance with the regulations specified in this manual and in all applicable European standards or national safety regulations.



WARNING : Equipment performance is only guaranteed if original spare parts distributed by SAMES Technologies are used.



WARNING : This equipment must only be used in spraying areas in compliance with standards EN 50176, EN 50177, EN 50223, or under equivalent ventilation conditions. To reduce health, fire and explosion risks, this equipment must only be used in well ventilated areas. The efficiency of the ventilation system must be verified on a daily basis.

Only appropriate explosion-proof electrical equipment must be used in the explosive atmospheres generated by the spraying process.

Before carrying out any cleaning or general work on atomizers in the spraying area, the high-voltage generator must be switched off and the HV atomizer circuit must be discharged to ground.

Never point the pressurized coating product or the compressed air towards persons or animals.

Suitable measures must be taken to prevent the presence of energy potential (liquid, air pressure or electrical) in the equipment during downtimes and/or periods when the equipment is not being used.

The use of individual protective means can limit the risks caused by contact and/or inhaling of toxic products, gases, vapors, mist and dust likely to be generated by the equipment when it is in use. The operator must follow the manufacturer's instructions for the coating product.

Electrostatic spraying equipment must be serviced regularly in accordance with the information and instructions given by SAMES Technologies.

Cleaning operations must be carried out either in authorized areas equipped with a mechanical ventilation system, or using cleaning liquids with a flash point at least 5°C higher than the ambient temperature.

Only metal containers may be used for cleaning liquids, and they must be safely grounded.

Inside the booth it is forbidden to use naked flames, glowing objects or devices likely to produce sparks.

It is also forbidden to store flammable products, or recipients that have contained them, in the vicinity of the booth.

The surrounding area must be kept clear and clean.



WARNING : The use of very high voltage increases the risk of sparks. SAMES Technologies atomizers and high-voltage electrostatic generators are designed to minimise this risk. Although the HV electrode is the only accessible part, a safety distance of X mm (see table below) must be observed between the HV parts of the atomizer and all grounded parts.

Authorised spraying distance

Voltage (kV)	Distance (mm)
0	100
50	110
60	120
70	135
80	150
90	165
100	180

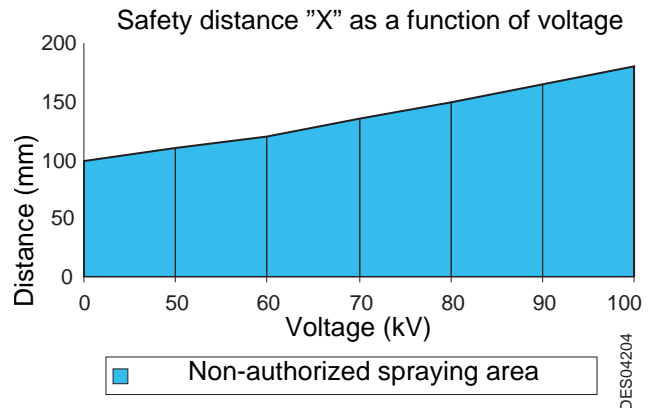

Any installation by isolated system (waterborne) must be equipped with a short-circuiter which acts in less than two seconds ($E < 350\text{mJ}$ in less than two seconds).

In addition, a careful check must be made to ensure that any conducting or semi-conducting part closer than 2.5 m to the atomizer is correctly grounded.

If it is not, electrical charges capable of causing sparks could build up on it. Operating personnel must wear anti-static shoes and gloves to avoid this risk.

Each substrate must have a ground resistance of less than or equal to 1 M Ω (measurement voltage of at least 500V). This must be checked regularly.

All conducting enclosures of electrical equipment and conducting components in explosive atmospheres must be grounded by connecting them to the grounding terminal.

Finally, for the same reasons, the spraying area must have an anti-static floor, such as concrete, metal duckboard, etc.

It is essential to provide sufficient ventilation in the spraying booths to avoid the build up of inflammable vapors.

The correct operation of the overcurrent protection (di/dt) must be verified daily. This verification must be carried out **in a non-explosive atmosphere**, by placing a ground wire near the atomizer electrode with the atomizer switched on (the operator must be grounded): the control module must switch to the fault state.

The associated equipment must be located outside hazardous areas, and its operation must be interlocked with that of the booth extraction fan. The correct operation of the servocontrol system must be verified once a week.

A warning sign must be placed in full view near the spraying area.

Excessive turbine speed can result in serious damage to the turbine and loss of connection between the bell cup and turbine, presenting a risk to persons and equipment. The maximum operating speed specified in this manual must not be exceeded ([see § 3.2 page 17](#)).

1.4.1. Installation Rules
PPH 707 ICWB M:

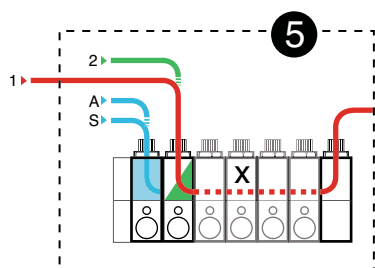
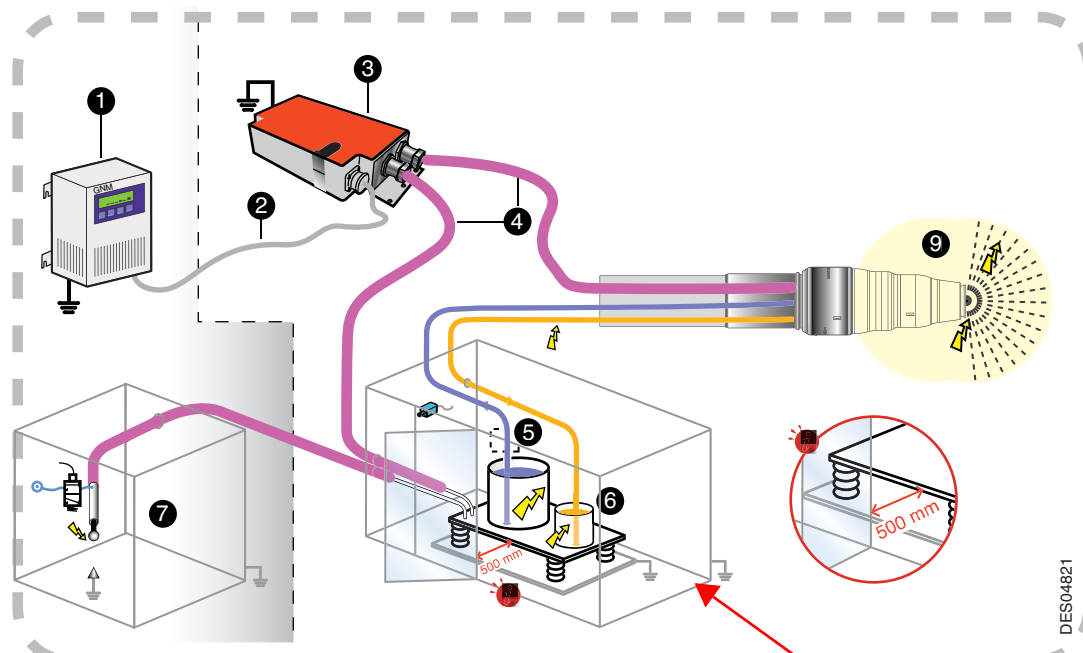

- S: rinsing product
- A: Air supply
- 1: Product 1 supply
- 2: Product 2 supply

Protection enclosure if system isolated out of paint booth

Nota: A connection to the ground of the shielding of the connecting cable between the HVU and the insulating table at exit of "cage" is imperative (see § 7.3 page 50).



WARNING : All the conductive parts must be connected to the high voltage potential (metallic fittings of the Moduclean, gear pump, etc...).

Waterborne paints non flammable and not easily flammable	
1	Control module GNM 200
2	Low voltage connection
3	High voltage unit UHT 288 EEx e
4	High voltage cable connecting UHT 288 / insulating table and UHT 288 / PPH ICWB M
5	Supplies of paints and rinsing products insulated to the ground potential
6	Dump return line insulated to the ground potential
7	Short circuiter
8	-
9	Safety distance (area around the atomizer head from the parts with high voltage, outer cover, bell cup, etc...)

1.5. Important Recommendations

1.5.1. Compressed air quality

The air must be filtered to a level that will guarantee a long life time and prevent any pollution during painting.

The filter must be installed as close to the installation as possible. The filter cartridges must be changed regularly to ensure that the air is clean.

Teflon tape or glue should not be used between the filter and the bearing as glue residue or pieces of Teflon may block the small holes of the air bearing and cause turbine failure.

The inside of hoses supplying air to the atomizer and the ports of the quick-disconnect plate must be clean and free of any traces of paint, solvent or other foreign matter.

The guarantee does not cover faults caused by unclean, unfiltered bearing air resulting from non-compliance with the previous recommendations.



WARNING : If the air is not correctly filtered, the bearing may become fouled resulting in a turbine operating fault. The filtering system used must prevent particles greater than 0,1 μm in diameter from reaching the bearing.



WARNING : The guarantee does not cover damage caused by foreign matter (paint, solvent or other foreign matter) entering the air circuits of atomizer PPH 707 ICWB M.

1.5.2. Product quality

The paint must be filtered to prevent any damage to the atomizer.

The maximum permissible particle size in the atomizer is 200 μm .

1.5.3. Bearing safety

The compressed air connection to the air bearing must be made directly via the supply circuit (without using an isolating valve). A sudden cutoff of the air supply may cause partial damage to the turbine air bearing, possibly resulting in system shutdown.

In addition, a 25-liter air reserve should be available so that the turbine brakes gradually if the main air supply is cut off suddenly.



WARNING : The guarantee does not cover faults that occur if the turbine is operated with insufficient bearing air pressure.

1.5.4. Locking

Do not atomise the product if the bell cup is not rotating at a speed of at least 15,000 rpm. At lower speeds, paint or solvent may enter the turbine, bearing and control circuits. Opening the head valve, the injector rinsing valve and the bell cup exterior rinsing valve must therefore be prohibited when the bell cup is not rotating. Only qualified personnel are authorised to by-pass this locking system for flow rate checks.



WARNING : If the turbine is not already operating, wait, after starting it up, until the bell cup reaches at least 15,000 rpm before opening the head valve. The recommended minimum waiting time is 2 seconds.

1.5.5. Shaping air

Do not atomize the product until the guiding air rate is at least 150 NI/min. If it is less, a feedback of atomized product may occur, possibly fouling the outer shaping air shroud (and the inside surface of the inner shaping air shroud) and resulting in faulty application.

1.5.6. High voltage

If atomizer PPH 707 ICWB M is not operating for a prolonged period (conveyor shutdown, unpainted objects, slack periods, etc.), switch off the high-voltage supply to prevent air ionisation.



WARNING : Rinsing cycles (bell cup exterior and injector) must be performed after previously switching off the high voltage supply.

1.5.7. Maximum speed

Excessive turbine speed can result in serious damage to the turbine and loss of connection between the bell cup and turbine, presenting a risk to persons and equipment. The speed must not exceed 85,000 rpm.



WARNING : The guarantee does not cover damage resulting from a rotation speed greater than 85,000 rpm.

1.5.8. Vibrations

If the atomizer vibrates abnormally, the cause is generally unbalanced rotating parts. If this is the case, the rotation speed will rapidly decrease, inevitably causing damage to the turbine. Paint deposits, damage or dry paint residues on the bell cup or fastening cone are the possible causes of a balancing defect. If significant vibration is observed, the problem must be immediately corrected. A significant imbalance of more than G 0.4 (1/1000 gr x 1cm radius) will inevitably deteriorate the turbine.



WARNING : The guarantee does not cover damage caused by imbalance of rotating parts.

1.5.9. Ventilation

Do not begin applying paint with atomizer PPH 707 ICWB M before starting up the ventilation system in the spraying booth. If the ventilation is cut, toxic substances such as organic solvents or ozone may remain in the spraying booth, resulting in a risk of fire, poisoning or irritation.

1.5.10. O-ring seals

Use the seals recommended in this manual. For solvent-based products, seals in contact with the product must be chemically inert seals resistant to swelling or chemical attack. The correct operation of atomizer PPH 707 ICWB M is only guaranteed if used with seals of sizes and materials in compliance with those specified in this manual.

1.5.11. Residual pressure

Before all maintenance or repair operations, remove paint and solvent from the atomizer, switch off the high voltage power supply and cut the paint, solvent and air supplies, then release residual pressure in each supply system. Residual pressure may lead to component damage and expose personnel to serious injuries. Paint or solvent dispersion may also lead to poisoning or irritation.

1.5.12. Safety devices

When implementing atomizer PPH 707 ICWB M, it is important to provide for safety devices allowing immediate cutoff of paint, solvent, air and HV power supplies in the event of a problem.

- Detection of control system faults.
- Detection of high voltage surges associated with the SAMES HV generator.
- Detection of air pressure drops.
- Detection of ventilation failure.
- Detection of fire.
- Detection of human presence.
- Detection of turbine rotation speed faults.

Failure to install safety devices could result in a risk of fire, expose the personnel to serious injury and damage the equipment.

1.5.13. Mechanical collision

The guarantee does not cover damage resulting from the operating environment (for example: collision).

1.5.14. Ambient temperature

The atomizer is designed to normally operate at an ambient temperature comprised between 0°C and + 40°C.

For optimal application quality, operation at an ambient temperature of between +15°C and + 28°C is recommended.

The storage temperature must never exceed +60°C.

1.5.15. Sound level

The weighted equivalent continuous sound pressure level is equal to 62.7 dBA.

Measurement conditions:

The equipment has been operated under maximum conditions. Measurements were taken in the paint test booth (sealed booth with glass panels) at the Sames R&D laboratory in Meylan, France.

Measurement method:

The weighted equivalent sound pressure level (62.7 dBA) is an LEQ value measured during observation periods over at least 30 seconds.

1.5.16. Special maintenance measures

All access to the booth near the atomizer must be controlled during atomizer operation by active devices ([see § 1.5.12 page 12](#)) designed to interrupt operation in case of personnel intrusion.

However, for maintenance purposes, these devices can be implemented with a view to allowing certain operations and inspections (by personnel trained and certified by Sames Technologies).

In all cases, turbine rotation with a bell cup will be prohibited when personnel are present nearby.

1.6. Guarantee

Under the guarantee, which applies only to the buyer, **SAMES Technologies** agrees to repair operating faults resulting from a design fault, materials or manufacture, under the conditions set out below.

The guarantee claim must define the exact nature of the fault concerned, in writing.

The **SAMES Technologies** guarantee only covers equipment that has been serviced and cleaned according to standard procedures and our own instructions, that has been fitted with parts approved by **SAMES** or that has not been modified by the customer.

More precisely, the guarantee does not cover damage resulting from:

- the customer's negligence or inattention,
- incorrect use,
- failure to follow procedures,
- use of a control system not designed by **SAMES Technologies** or a **SAMES Technologies** control system modified by a third party without written permission from an authorized **SAMES Technologies** technical agent,
- accidents such as: collision with external objects, or similar events,
- flooding, earthquake, fire or similar events,
- inadequately filtered bearing air (solid particles more than 0.1 µm in diameter),
- inadequately filtered paint and solvent,
- use of seals not complying with **SAMES Technologies** recommendations,
- starting up turbine rotation without minimum bearing air pressure (5.5 bar),
- exceeding the maximum speed of 85,000 rpm under load,
- starting up rotating parts that are unbalanced (dry paint on bell cup / rotor or damaged bell cups),
- pollution of air circuits by fluids or substances other than air.

The **SAMES Technologies** atomizer **PPH 707 ICWB M** is covered by a one-year guarantee for use in two 8-hour shifts under normal operating conditions.

By concession, the guarantee is extended to 10000 hours on the air turbine of atomizer **PPH 707 ICWB M**. The guarantee does not apply to wearing parts such as atomizing bell cups, diaphragms, seals, etc.

The guarantee will take effect from the date of the first start-up or of the provisional acceptance report.

Under no circumstances, either in the context of this guarantee or in other contexts, will **SAMES Technologies** be held responsible for physical injury or intangible damage, damage to brand image and loss of production resulting directly from its products.

2. Description

2.1. General

Atomizer **PPH 707 ICWB M** is a high-performance atomizer with rotating bell cup. It incorporates the advantages of previous generations, with added power. It is designed for high spray rates.

Equipped with an air bearing turbine for a magnetic-resistant bell cup, **PPH 707 ICWB M** atomizer is used to atomize and apply various types of paint at a recommended rotation speed of 80,000 rpm.

Its modular design allows rapid installation and easy maintenance.

Main components:

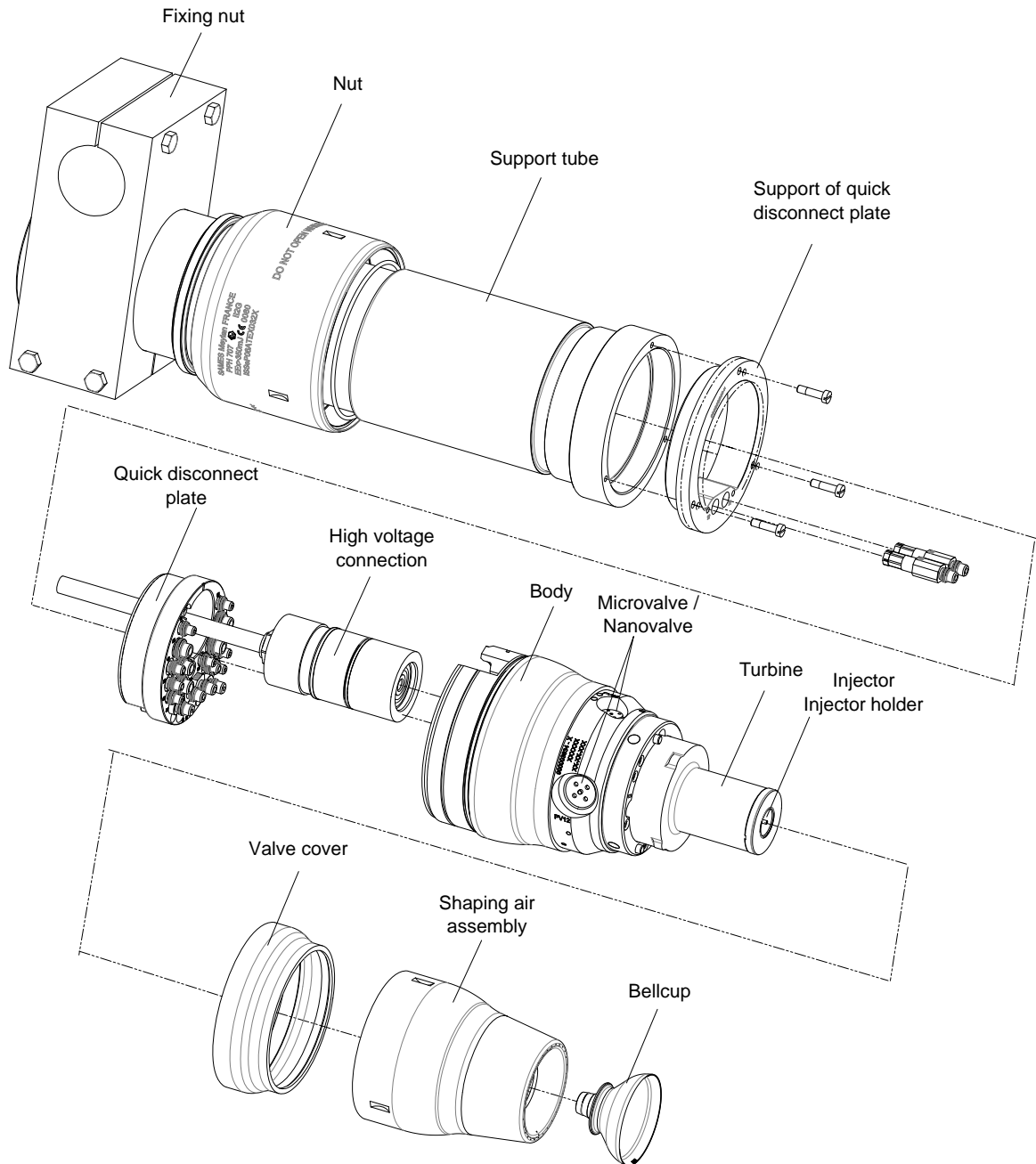

DES04823

2.2. Function of the parts

Part	Function
Bell cup	The bell cup atomizes all types of paint.
Shaping air assembly (Outer cover / Shaping air shroud)	These parts control the size and pattern diameter and transfer the particles to the parts to be painted. They protect internal components and allow easy cleaning.
Turbine	The rotation of the bell cup is produced by a pneumatic motor. Atomization results from the centrifugal forces generated by rotation of the bell cup.
Injector / Injector holder	The injector transfers products to the bell cup. The holder retains the injector and allows it to be rinsed.
Body assembly	This part houses all fluid circuits and air/solvent microvalves and nanovalves. It supports the turbine and the shaping air assembly.
Nanovalue and microvalve	Air-controlled, 2-way, normally closed valves used for various operations: paint supply, paint rinsing, bell cup exterior rinsing, injector rinsing.
Quick-disconnect plate	Provides a sealed interface for intake of fluids and air preventing any contamination. Allows quick installation and removal of the atomizer during production.
Nut	It secures the body on the support tube.
High voltage connection	Supply with high voltage the PPH 707 ICWB M atomizer from the external high voltage unit.

3. Technical characteristics

3.1. Dimensions (mm)

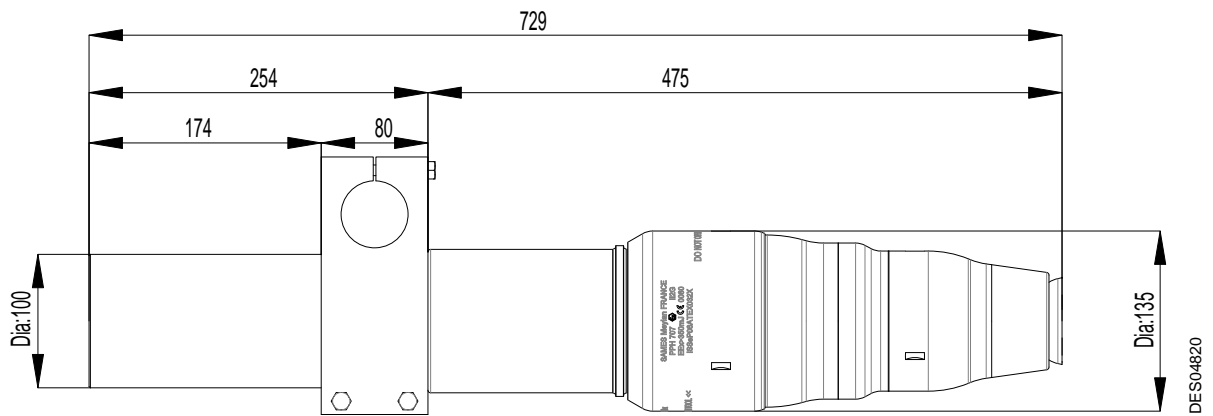

3.2. Operating characteristics

Weight		
	Atomizer without cable or hose	8.5 kg
Voltage		
	Maximum operating voltage	100 kV
	Maximum operating current	500 μ A
Speed		
	Recommended rotation speed	15 to 80 Krpm.
Paint		
	Flow rate	30 to 1000 cm ³ /mn max. (depending on paint)
	Normal supply pressure	6 to 8 bar
	Maximum pressure	10 bar
	Viscosity	20 to 40 seconds - FORD cup n° 4
	Viscosity	20 to 45 seconds - AFNOR cup n° 4
Air pressure		
	Nanovalve pilot	8 bar (min.) - 10 bar (max.)
	Microvalve pilot	6 bar (min.) - 10 bar (max.)
	Bearing air	5.5 bar (min.) -7 bar (max. at 130 l/min)
	Shaping air	6 bar maximum
	Microphone air	0.5 to 1 bar constant
Air quality		
	Filtered air (bearing air) must be dry and free of oil and dust as per DIN ISO 8573-1 Class 1	
	Maximum dewpoint at 5.5 bar (80 psi)	Class 2 i.e - 40°C (-40°F)
	Maximum particle size of solid contaminant (Bearing air)	Class 0 i.e \varnothing 0,1 μ m
	Maximum particle size of solid contaminant (Turbine rotation)	Class 1 i.e \varnothing 1 μ m
	Maximum particle of solid contaminants (Others)	Class 3 i.e \varnothing 5 μ m
	Maximum concentration of oil	Class 1 i.e 0,01 mg / m ₀ ³ *
	Maximum concentration of solid contaminants	1 mg / m ₀ ³ *
Air consumption		
	Pilot	10 NI/min.
	Bearing air	125 NI/min.
	Shaping air	200 to 850 NI/min.
	Turbine	see RT Nr 6354

* m₀³ values given for a temperature of 20°C and an atmospheric pressure of 1,013 mbar.

3.3. Operating principle

3.3.1. Turbine

[see RT Nr 6354](#)

The turbine is equipped with an air bearing that separates the transmission shaft and drive vane from the main body of the turbine. This eliminates friction between the various components, ensuring long component life and allowing high rotation speeds.

The air directed onto the turbine blades controls the rotation or braking of the turbine.

Atomisation of the product takes place thanks to the centrifugal forces created by the rotation of the bell cup. The size of the atomised particles decreases as the rotation speed increases.

3.3.2. Rotation speed measurement

3.3.2.1. With microphone

The rotation speed is measured acoustically. Air is supplied between the rear flange and the shaft. Each bell cup rotation, air passes through a groove machined on the shaft. This variation in pressure generates a signal whose frequency is proportional to the rotation speed and which is returned to the microphone through the turbine (via the atomizer body). The microphone ([see RT Nr 6190](#)) converts this signal into electrical pulses that are in turn transmitted to a control board.



WARNING : The 'microphone return' hose must be less than 4.5 m long to avoid loss of acoustic signal at the microphone.

Due to the high speed of the turbine, a resonance frequency may be generated in a hose longer than 4.5 m. The resonance frequency causes a stationary wave that inhibits the acoustic signal at the microphone.

3.3.2.2. With optical fiber

The turbine rotation speed is measured optically.

The optical fiber assembly (Ref.: 910005174) includes two fibers and two end pieces with display ports. One of the two fibers conducts a continuous light signal, which in turn reflects a discontinuous signal onto the turbine shaft (target: see illustration below). The frequency of this discontinuous signal is used to determine the rotation speed of the shaft (2 light pulses/turbine revolution).

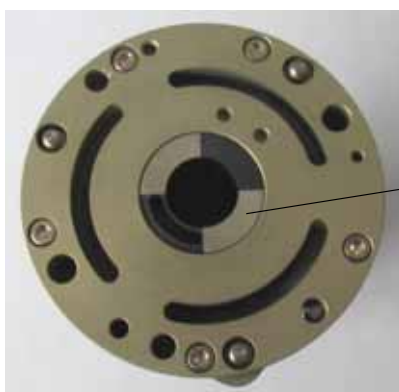

Target
(must be already
clean)

The discontinuous signal is transmitted by the second fiber, leading to an electro-optical converter (Ref.: 110000846AT) via the 8 m-fiber optical kit (Ref.: 910005172), installed in the quick-disconnect plate. The output signal from this electronic pulse sensor is recovered and analysed using a suitable counting system such as Frequency/Voltage (Ref.: 1525628).

At a rotation speed of 70,000 rev/min, the frequency would be 2.16kHz (2 pulses/revolution).

4. Fluid diagram

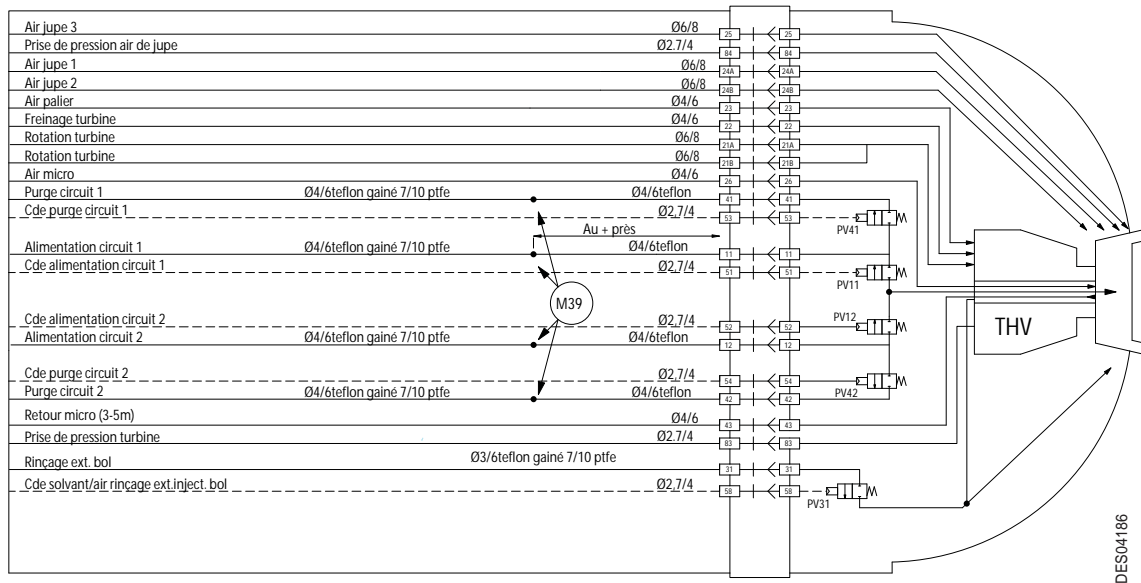

Marking no.	Function	Hose characteristics
11	Paint circuit 1 supply	4 /6 PTFE
12	Paint circuit 2 supply	4 /6 PTFE
21A	Turbine rotation 1	6/8 Rilsan
21B	Turbine rotation 2	6/8 Rilsan
22	Turbine braking	4/6 Rilsan
23	Bearing air	4/6 Rilsan
24A	Shaping air 1	6/8 Rilsan
24B	Shaping air 2	6/8 Rilsan
25	Shaping air 3	6/8 Rilsan
26	Microphone air IN	4/6 Rilsan
31	Injector and bell cup exterior rinsing air/solvent	3 /6 PTFE
41	Circuit 1 dump	4 /6 PTFE
42	Circuit 2 dump	4 /6 PTFE
43	Microphone return (OUT)	4/6 Rilsan
51	Pilot of paint circuit 1 supply	2.7/4 Rilsan
52	Pilot of paint circuit 2 supply	2.7/4 Rilsan
53	Circuit 1 dump pilot	2.7/4 Rilsan
54	Circuit 2 dump pilot	2.7/4 Rilsan
58	Pilot of injector and bell cup exterior rinsing air/solvent	2.7/4 Rilsan
83	Remote bell cup (RBC)	2.7/4 Rilsan
84	Shaping air pressure tap (RSA)	2.7/4 Rilsan



WARNING : Teflon hoses must never be replaced with Rilsan hoses. Only polyamide hoses can be used for air connections. Polyurethane hoses are prohibited.

Note:

**Blue colored hoses are used for the various types of air supply.
Non-colored hoses are used for products.**



WARNING : 11,12,41,and 42 (4/6 PTFE) hoses and 31-hose (3/6 PTFE) will have to be sheathe with 7/10 PTFE hoses. The overall length of the sheath must be approximately 5 cm lower than the length of the hoses. Screw two sealing unions (P/N: 910006017) of each hose (one at the quick disconnect side, the second at the other end of the sheath).

RSA (Remote Shaping Air) function: Inlet 84 is a shaping air pressure tap used to check flow rate/ pressure conformity during operation.

For a given flow rate D1, there must be a corresponding pressure P1 (identification / mapping of shaping air flow rate as a function of RSA pressure).

During production, the RSA pressure can be monitored as a fonction of the shaping air flow rate:

- RSA pressure < P1: air leak (shroud incorrectly fastened, punctured hose, etc.)
- RSA pressure > P1: clogged shaping air holes or bent hose

RBC (Remote Bell Cup) function: Inlet 83 is a pressure tap used to measure a pressure proportional to the bell cup resistance force (magnetic clip).

This pressure must exceed 1.5 bar.

- RBC pressure \leq 0.6 bar: bell cup not present
- 0.6 bar < RBC pressure < 1.5 bar: insufficient resistance force (dirty turbine fastening cone, damaged bell cup cone)

- When the RBC pressure is less than 1.5 bar, the ' bell cup retaining/presence' fault is activated, inhibiting the rotation and activation of the paint supply valve (except in maintenance mode, to perform paint flow rate measurements).

- **QD check:** Function associated with the RBC function. When the RBC pressure is less than 1.5 bar, a 'QD check problem' fault is also activated. The problem may be due to an incorrectly fastened quick-disconnect (QD) plate and/or to a bell cup retaining/presence problem.

The operator is prompted to check these components and production is interrupted (the atomizer cannot be used with this fault).

5. Startup

5.1. Tools

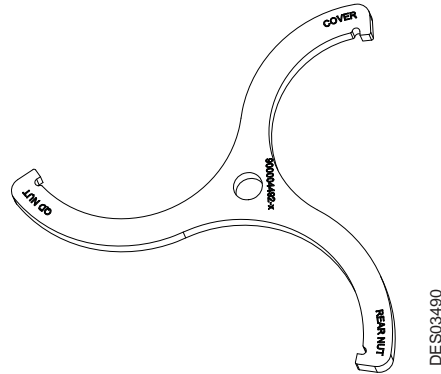

P/N	Description	Qty	Unit of sale
900004492	Installation/removal tool for outer cover and rear nut	1	1

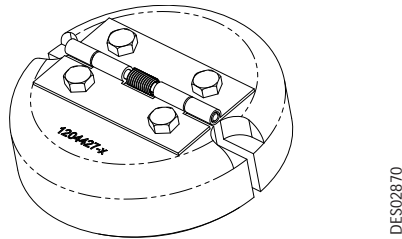

P/N	Description	Qty	Unit of sale
900000803	Removal tool for EC 50 magnetic bell cup	1	1
1204427	Removal tool for EX 65 magnetic bell cup	1	1

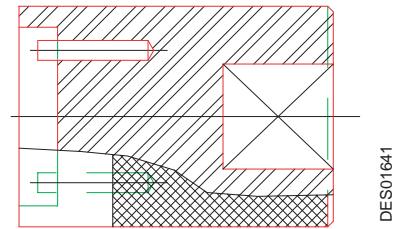
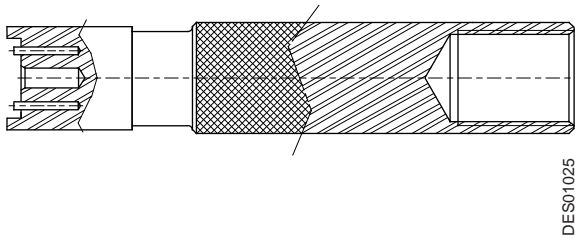

P/N	Description	Qty	Unit of sale
1301832	Removal tool for nanovalve	1	1
1403498	Automatic tightening tool for nanovalve	1	1

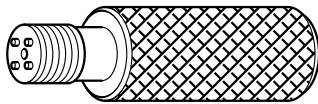

DES00039

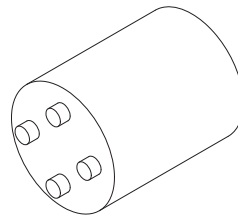

DES01673

P/N	Description	Qty	Unit of sale
1303689	Removal tool for microvalve	1	1
1403478	Automatic tightening tool for microvalve	1	1

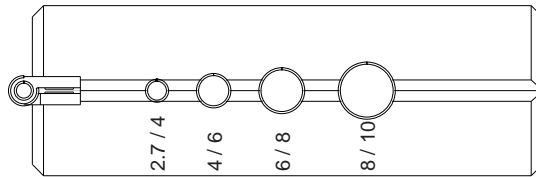

DES03489

P/N	Description	Qty	Unit of sale
1313955	Installation tool for fittings	1	1

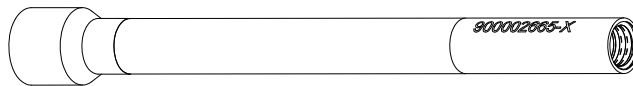

DES03969

P/N	Description	Qty	Unit of sale
900002665	Trapezoidal tool for clipped fittings	1	1

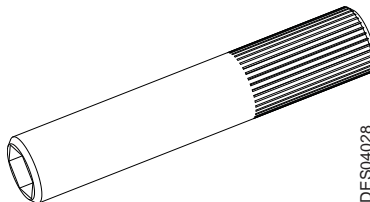

DES04028

P/N	Description	Qty	Unit of sale
910000700	Removal tool for injector	1	1

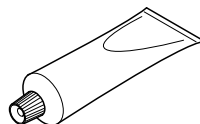

DES00685

P/N	Description	Qty	Unit of sale
H1GMIN017	White vaseline (100ml)	1	1
H1GSYN037	Red dielectric grease	1	1

Additional tools and accessories required:

The tools listed below should be available for product installation and maintenance operations.

- Hose cutter (P/N W3SCTU002)
- Screwdriver (small and medium)
- Allen wrench (3.4 mm)
- Torque wrench
- Fine brush
- Flat wrenches (9 and 12 mm)
- Cylindrical brush

5.2. Installation

- **Step 1:** Loosen the two fastening screws and withdraw the quick disconnect plate from the rear support.
- **Step 2:** Pass the hose bundle (air and product hoses) through the support tube. Pass one by one the hoses through the quick disconnect plate by respecting their location. Fasten the quick disconnect plate with the two screws on the rear support.

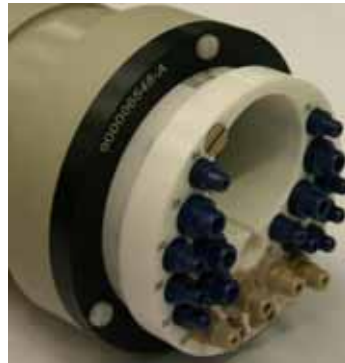

- **Step 3: Installation of high voltage connection:** Slide the high voltage connection into the support tube through the quick disconnect plate, then push it in all the way and fasten the fastening screw (clockwise).



- **Step 4:** Place the body in front of the high voltage connection and while screwing manually the nut ([see § 7.4 page 51](#)) put the body on the quick disconnect plate, place the split ring behind the nut and secure with tool (P/N 900004492).
- **Step 5:** Slide the nut on the rear support.

5.3. Shutdown and startup procedures

Important recommendations:

Comply with the air settings given in Section 3.2.

The bearing air pressure must be at least 5.5 bar at the quick-disconnect plate.

Check that the speed regulating module transmits a signal.

5.3.1. Shutdown procedure

Important steps be observed:

		Step 1	Step 2	Step 3	Step 4	Step 5
Stop atomising.	Sequence chart					
Switch off the high-voltage power supply						
Run a rinsing cycle						
Cut off the shaping air						
Cut off the turbine rotation air (*)						
Cut off the bearing air						



WARNING : * Wait until the turbine has stopped completely stop: 0 rpm.

5.3.2. Start-up Procedure

Important steps to be observed:

		Step 1	Step 2	Step 3	Step 4
Switch on the bearing air supply	Sequence chart				
Start up turbine rotation					
Switch on the shaping air supply					
Switch on the high voltage supply					
Start up atomisation					

6. Maintenance

6.1. Summary table of maintenance operations

Procedure	Description	Preventive	Corrective	Duration	Frequency
A	Cleaning of atomizer exterior, outer cover, and bell cup exterior	X		5 mn	8 hours
B	B1 Cleaning of bell cup	X		2 mn	40 hours
	B2 Cleaning of outer cover	X		8 mn	40 hours
	B3 Cleaning of injector exterior	X		4 mn	40 hours
C	C1 Cleaning of turbine	X		2 mn	520 hours
	C2 Cleaning of injector and injector holder	X		2 mn	520 hours
	C3 Cleaning of displays ports (optical fiber system)	X		2 mn	520 hours
D	Maintenance of the body				
	D1 Body installation/removal		X	< 5 mn	
	D2 Replacement of o-rings		X	15 mn	> 10000 hours
	D3 Replacement of solvent pipette		X	5 mn	> 10000 hours
	D4 Replacement of nanovalves		X	5 min.	2.5 million cycles
	D5 Replacement of microvalves		X	5 mn	3 million cycles
	D6 Replacement of high-speed turbine		X	< 5 mn	> 10000 H
D7 Replacement of optical fiber system		X	< 5 mn	> 10000 H	
E	Maintenance of quick-disconnect plate				
	E1 Hose replacement		X	10 mn	12 to 24 months
	E2 Replacement of fitting		X	5 mn	> 10000 H
	E3 Replacement of high voltage connection		X	5 mn	> 10000 H
	E4 Replacement of quick-disconnect plate		X	30 mn	-

6.2. Preventive maintenance

These maintenance operations can be performed online. Always refer to the health and safety instructions before carrying out any work ([see § 1.4 page 6](#)).

6.2.1. Procedure A: Atomizer exterior



WARNING : Before any cleaning operation, it is imperative to ensure there is no high voltage nor remanent electrostatic charge.

In fact:

- Ensure that the GNM 200 control module does not deliver high voltage.
- **Pass a rag humidified with water on the atomizer to run out all charges** ([see § 1.4 page 6](#)). If high voltage is present, if rag soaked with solvent is in the vicinity, there is a main risk of ignition.



WARNING : Then, all the cleaning operations will be done with a rag soaked in solvent and a clean, dry and non-fluffy rag in order to dry all the parts concerned perfectly. It is strictly prohibited to use a manual solvent gun.



WARNING : Soak the body of the atomizer in a liquid of cleaning without integral disassembling of all its components is strictly prohibited. It is imperative to remove the spraying head, valves, o-rings by using suitable tools ([see § 5.1 page 21](#)) then dry all the parts perfectly.

If this information is not respected, there is a risk of total deterioration of the atomizer imposing its replacement which is not covered by the Sames guarantee.

1	Grooves on the outer cover
2	Outer cover
3	Bell cup

- Clean the outer cover and the bell cup exterior with a clean cloth.
- Check that the grooves on the outer cover are clean.

- Dry carefully with compressed air.

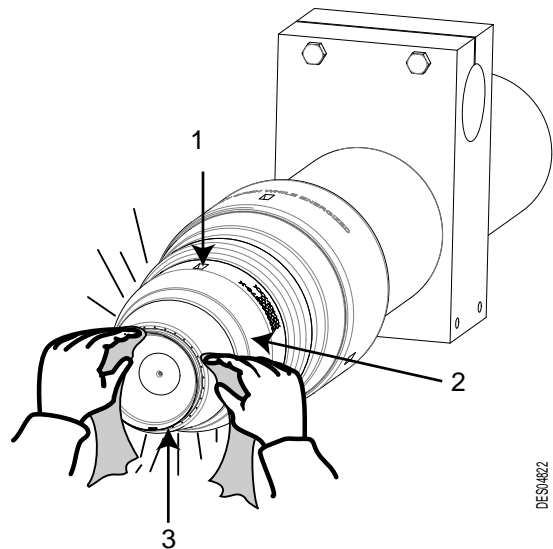

DES/14822

6.2.2. Procedure B1: Magnetic bell cup



WARNING : All bell cup maintenance or handling operations must be performed with extreme care, since the bell cup is balanced.



WARNING : Stop the turbine and cut off the shaping air. The bearing air remains pressurized.

- Remove the magnetic bell cup using the suitable tool, [see RT Nr 7070](#).
- Carry out a visual inspection.
- Let the bell cup soak for one hour in an appropriate solvent, then clean with a clean cloth and soft brush.



WARNING : Make sure that all surfaces are clean and completely free of impurities, particularly the inner and outer surfaces of the bell cup fastening cylinder.

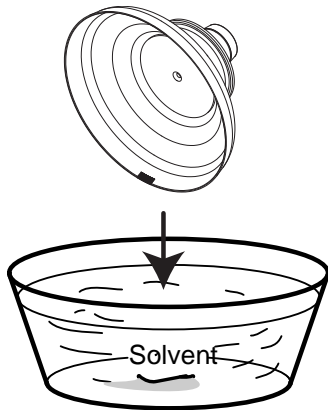

DES02807

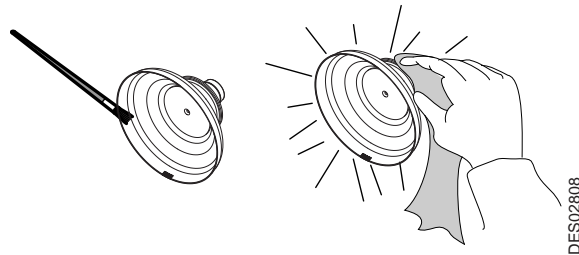

- Dry carefully with compressed air.

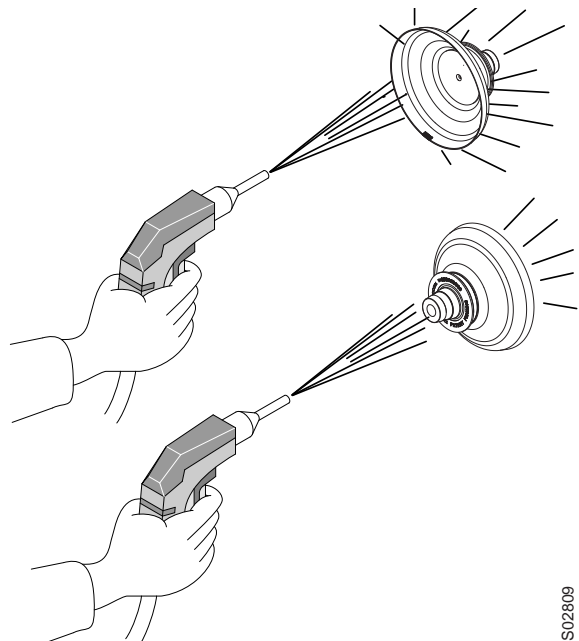

- Reinstall the bell cup on the atomizer.

6.2.3. Procedure B2: Shaping air assembly

- The bell cup has been previously removed.
- Begin to loosen the outer cover with tool P/N 900004396, then continue manually, [see RT Nr 7070](#).
- Remove the outer cover, then remove the inner shaping air shroud.
- Carry out a visual inspection of the components (outer cover, shaping air shroud and O-rings), replace if necessary, then clean the outer cover:

- **Step 1:** Let the outer cover soak in solvent for one hour, then clean the outer and inner surfaces with a clean cloth soaked in solvent.

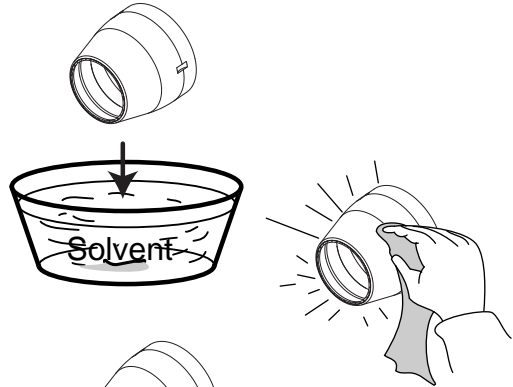

- **Step 2:** Use a nylon brush to clean the holes on the front face of the outer cover.

- **Step 3:** Clean carefully with compressed air (concentrating on the holes to eliminate paint residues), then wipe with a clean, dry cloth.

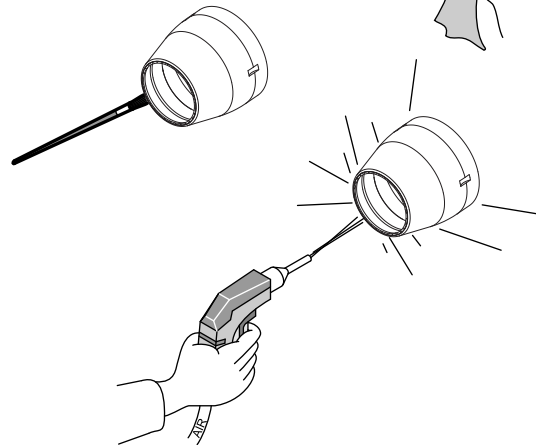

- Check the condition of the inner shaping air shroud and, if necessary, clean it with a cloth soaked in solvent.

- Reinstall the shaping air assembly, [see RT Nr 7070](#).



WARNING : Keep the threading between the outer cover and the body clean. Coat the threading with vaseline to facilitate the reinstallation of the outer cover.

DES03378

6.2.4. Procedure B3: Injector exterior

Proceed with the bell cup and shaping air shroud assembly previously removed.

- Use a brush slightly soaked in solvent to clean the injector exterior.



- Dry carefully with a clean, dry, non-fluffy cloth.

6.2.5. Procedure C1: Turbine

- Proceed with the bell cup and shaping air assembly previously removed.

- Loosen the three turbine fastening screws.

3 captive screws

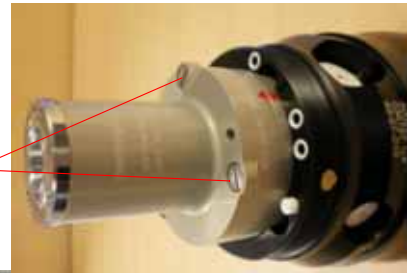

- Clean the turbine interior with a cylindrical brush.



- Clean the turbine exterior with a soft, non-fluffy cloth.



WARNING : Do not soak the turbine in solvent.

- Prior to reinstalling the turbine on the body, check the condition of the O-rings, replace them if necessary, and make sure that they are all presents.

- Position the turbine on the body by aligning the marking on the turbine (red arrow) with that on the body.
Tighten the three fastening screws (tightening torque: 2.2 Nm).



6.2.6. Procedure C2: Injector / Injector holder

- Proceed with the bell cup, shaping air assembly and turbine previously removed.

- Use a 9-mm flat wrench to loosen the injector/diffuser assembly. Withdraw the injector from the diffuser by pushing it carefully.



WARNING : All operations on the injector must be performed carefully.

- Clean the injector and diffuser with a soft brush previously soaked in solvent.
- In case of very significant soiling: Let the injector soak for one hour in an appropriate solvent and dry carefully with compressed air.
- Remove the injector holder, if necessary (three M3x8 screws).
- Check the condition of the injector O-rings. Replace them if necessary.
- Position the injector holder (aligning it with the locating pin) and fasten it using the three M3x8 screws (tightening torque: 1.7 Nm).
- Insert the injector and o-ring into the diffuser, do not tighten securely, place the o-ring on the diffuser, place the assembly in the injector holder, then tighten manually.

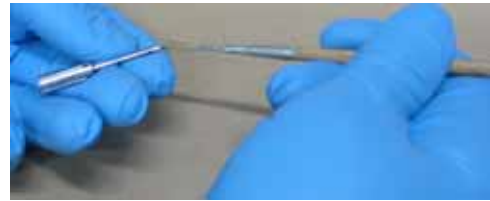

- Screw the injector in the injector holder using installation tool P/N 91000700 and a torque wrench (tightening torque: 2.2 Nm).



Tool P/N 91000700



6.2.7. Procedure C3: ports from optical fiber system

The optical fiber may remain in position while ports are being cleaned.

Using a soft, lint-free cloth and an appropriate solvent, clean the ports and dry them carefully.

6.3. Corrective maintenance

The following operations are preferably performed in a workshop.

6.3.1. Procedure D1: Body installation/removal

- **Remove the body:** Unscrew the PPH nut then pull the body assembly along the axis.
- **Reinstall the body:** Proceed in reverse order.

6.3.2. Procedure D2: Replacement of body o-rings

- Check the condition of the o-rings on both faces of the body and replace if necessary.
O-ring kit (turbine side) P/N 910003415.
O-ring kit (quick-disconnect plate side) P/N 910003416.



WARNING : Prior to reinstalling the body on the rear support, make sure all the o-rings are present.



Body turbine side



Body quick-disconnect plate side

6.3.3. Procedure D3: Replacement of solvent pipette

- **Remove the solvent pipette:**
This operation automatically destroys the solvent pipette.
If absolutely necessary, remove the solvent pipette using an M1.6x 0.35 screw.
Replace the solvent pipette and install it in the body.

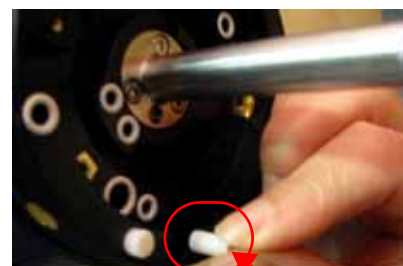

Solvent pipette

6.3.4. Procedure D4: Replacement of nanovalves

- **Remove the nanovalves:**
[see RT Nr 6258](#) for the operations listed below.
Remove the nanovalves using tool P/N 1301832.
Check their condition, clean them, and replace if necessary.



Nanovalves

6.3.5. Procedure D5: Replacement of microvalves

- **Remove the microvalves:**
[see RT Nr 6021](#) for the operations listed below.
Remove the microvalves using tool P/N 1303689.
Check the condition of the microvalves (paint supply microvalves PV11 and PV12), clean them, and replace if necessary.



Microvalves

6.3.6. Procedure D6: Replacement of high-speed turbine

- **Remove the turbine:**
Loosen the three captive screws. Pull the turbine along the axis.
- **Install the turbine:**
Position the turbine on the body by aligning the marking on the turbine (red arrow) with that on the body.
Tighten the three fastening screws (tightening torque: 2.2 Nm).

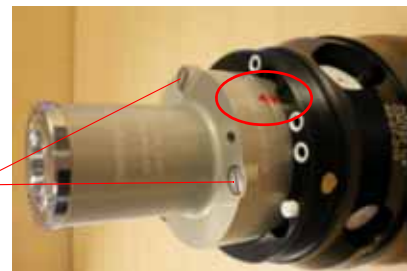

3 captive screws

6.3.7. Procedure D7: Replacing optical fiber

The turbine has been removed in advance:

- Remove the end piece at the quick disconnect plate using a hook while pulling under the angular positioning flat.
- Push back the two visible fibres inside the body.
- Remove the end piece and its two fibres at the turbine end.



Reassembly:

- Position the end piece on the quick disconnect plate in the body.
- Insert the two fibres in their housing at turbine end and push inside body.
- Push in two ends pieces fully; they are secured by two o-rings.



6.3.8. Procedure E1: Hose replacement

- **Hose replacement:**

It is not necessary to separate the quick-disconnect plate from the rear support in order to access the fittings or hoses or remove the cover.

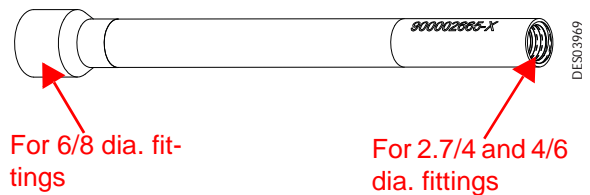

- Position tool P/N 90002665 on the fitting. Screw.



- Withdraw the fitting by pulling it along the axis using the tool.

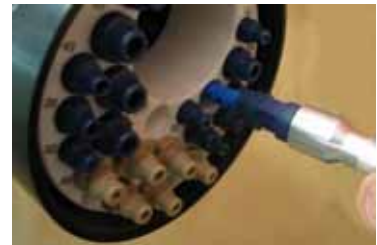

- **To replace the hose**, use the old hose as a needle and pull the assembly until the new hose protrudes from the quick-disconnect plate.



WARNING : When replacing a hose, ensure that there is sufficient length for disassembly at a later stage. The hoses must be secured so that they cannot be torn out.



WARNING : Replace all hoses every 12 to 24 months, depending on the amount of use.

6.3.9. Procedure E2: Replacement of fittings

- **Remove the air fitting from the hose:** Hold the hose using tool P/N 1313955, insert the hose in the orifice corresponding to the hose diameter, and loosen using a flat wrench with diameter corresponding to the fitting diameter.



- **Remove the product fitting:** Loosen the nut while holding the fitting with two flat wrenches, then withdraw the fitting from the tube by pulling along the axis (slightly rotating the fitting).



- To merely replace the fitting, cut the hose approximately 20 mm from its end using the tube cutter (P/N W3SCTU002). Caution: The cutting plane must be perfectly perpendicular to the hose.



Reinstallation of fittings:

- **Air fitting:** Push the hose into the fitting and tighten securely (for fittings P/N 910002946, 910002947, 910002948 and 910004923).
- **Product fitting:** For screwed fittings (P/N 910003345 and 910002950), fit the nut on the hose, push the hose onto the fitting body until the shoulder, and tighten the nut. For the fitting (P/N 910003413) proceed as the air fittings.

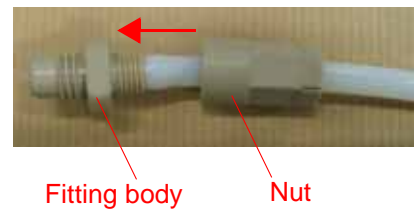

6.3.10. Procedure E3: Replacement of high voltage connection

- Remove the body.
- Withdraw the high voltage connection, loosen the fastening screw.

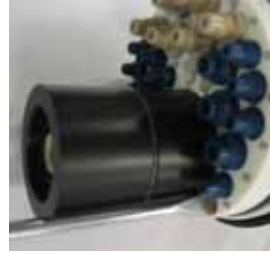

- Then pull the high voltage connection.

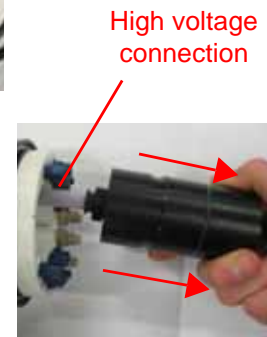

- Position the new high voltage connection after previously coating the high voltage well with dielectric grease. Push it all the way and fasten the fastening screw (clockwise).

6.3.10.1. Preparation of the high voltage connection

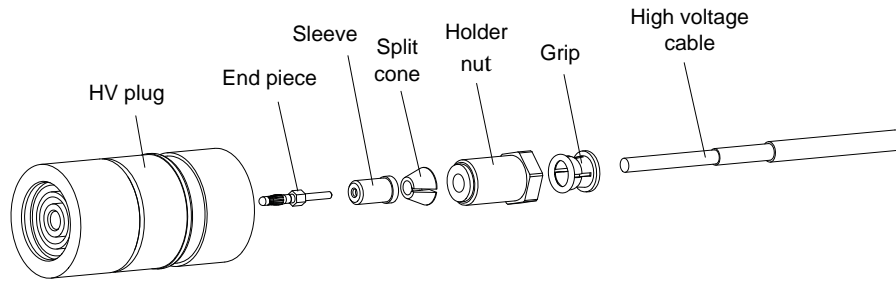

DES04190



WARNING : Ensure not to damage the insulating jacket. The smallest nick or mark in the insulating jacket will cause the cable breakdown.

- **Step 1:** Strip using a tool type strip-cable (rice grain) the high voltage cable over 33.5 cm length for the violet sheath then strip the semiconductor sheath (black sheath) by peeling it and cut it using pliers on the same length. It is imperative not to use a standard tool slicing "cutter".



Step 1

- **Step 2:** Insert the seal the grip in the nut



Step 2

- **Step 3:** Thread the nut equipped, split cone and sleeve must be kept against the cable.



Step 3

- **Step 4:** Insert the end piece in the high voltage cable, screw it manually then using a 6 mm open end wrench, tighten it until it stops.



Step 4





- **Step 5: Greasing**

- Coat the high voltage connection assembly (cable end piece, sleeve, split cone, grip holder) with a fine layer of dielectric grease, insert dielectric grease between the cable and the protective tube on the stripped part, use a syringe if necessary.

- **Step 6:** Pass the high voltage cable as above through the high voltage plug. Install the HV plug on the equipped cable, tighten the grip holder nut on the plug with an open end wrench. Connect the 10/12 protective tube in the grip. Coat sufficiently with dielectric grease the baffle plates of the plug and the outside of the plug with a brush.



WARNING : The high voltage cable must be imperatively sheathed with a 10/12 polyamide tube.

6.3.11. Procedure E4: Replacement of quick-disconnect plate

- Loosen the two fastening screws (M5x15) and withdraw the quick-disconnect plate.
- Remove the fittings from each hose ([see § 6.3.9 page 37](#))
- Position the new quick-disconnect plate and the hoses, then reinstall the fittings ([see § 6.3.9 page 37](#)).
Place the quick-disconnect plate on the rear support and tighten the two screws.



7. Spare parts list

Nota: Bell cup and shaping air assembly are not included.

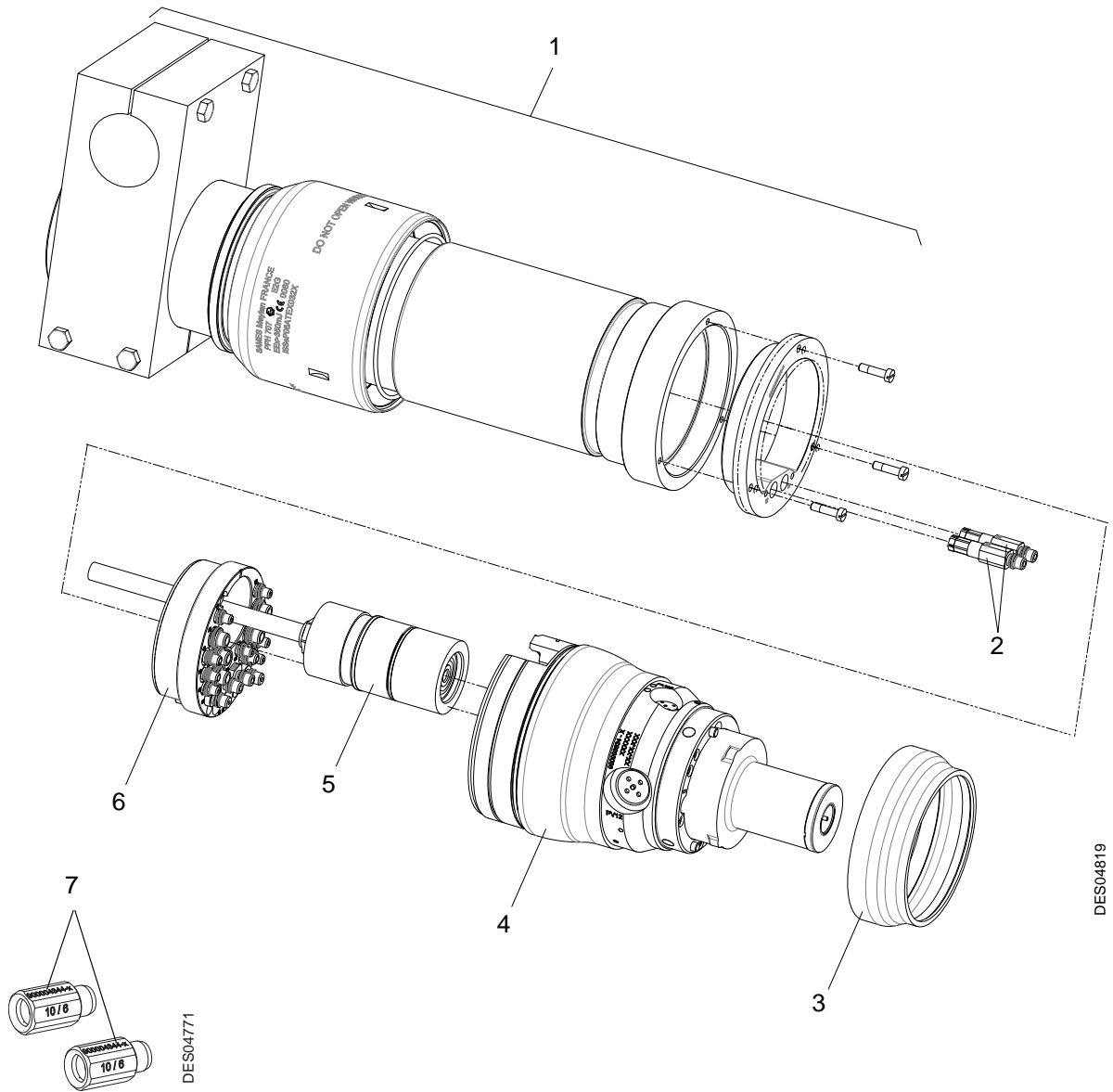

Item	P/N	Description	Qty	Unit of sale	Maintenance level for spare part (*)
	910009002	PPH 707 ICWB M	1	1	3
	910009002FO	PPH 707 ICWB M with optical fiber	1	1	3
1	910009076	PPH 707 ICWB M support assembly (see § 7.4 page 51)	1	1	3
2	910002950	4/6 product fitting	2	1	1
3	900002645	Valve cover	1	1	2
4	910005624SAV	PPH 707 ICWB M body assembly (see § 7.1 page 43)	1	1	3
	910005624FO SAV	PPH 707 ICWB M body assembly with optical fiber (see § 7.1 page 43)	1	1	3
5	910009188	High voltage connection (see § 7.3 page 50)	1	1	3
6	910003409	Quick disconnect plate assembly (see § 7.2 page 49)	1	1	3
7	910006017	Sealing fitting for 10/6-hose	10	1	2

(*)

Level 1: Standard preventive maintenance

Level 2: Corrective maintenance

Level 3: Exceptional maintenance

7.1. PPH 707 ICWB M body assembly

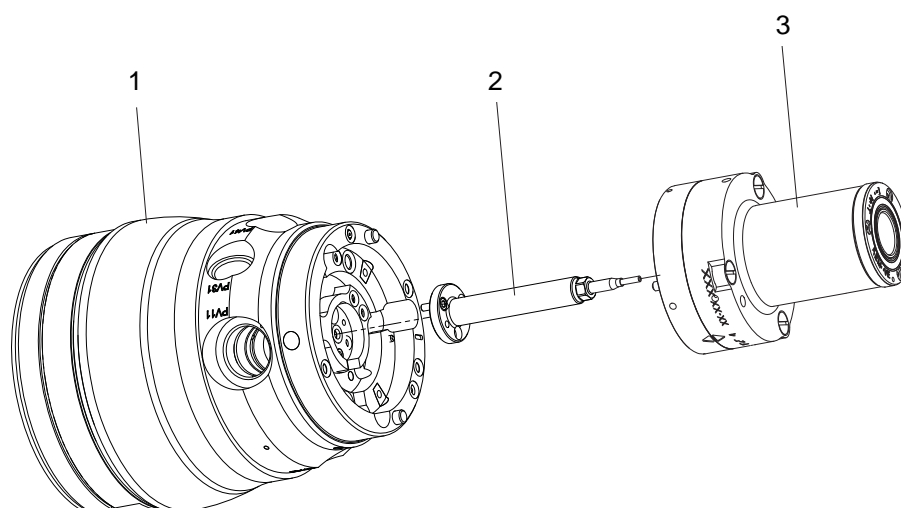

DES04088

Item	P/N	Description	Qty	Unit of sale	Maintenance level for spare part (*)
	910005624SAV	PPH 707 ICWB M body assembly	1	1	3
	910005624FO SAV	PPH 707 ICWB M body assembly with optical fiber	1	1	3
1	910005623SAV	PPH 707 ICWB M body (see § 7.1.1 page 44)	1	1	3
	910005623FO SAV	PPH 707 ICWB M body with optical fiber (see § 7.1.2 page 47)	1	1	3
2	910000618	Injector / Injector holder assembly (see § 7.1.3 page 48)	1	1	3
3	1525849	High speed turbine (see RT Nr 6354)	1	1	3

(*)

Level 1: Standard preventive maintenance

Level 2: Corrective maintenance

Level 3: Exceptional maintenance

7.1.1. PPH 707 ICWB M body

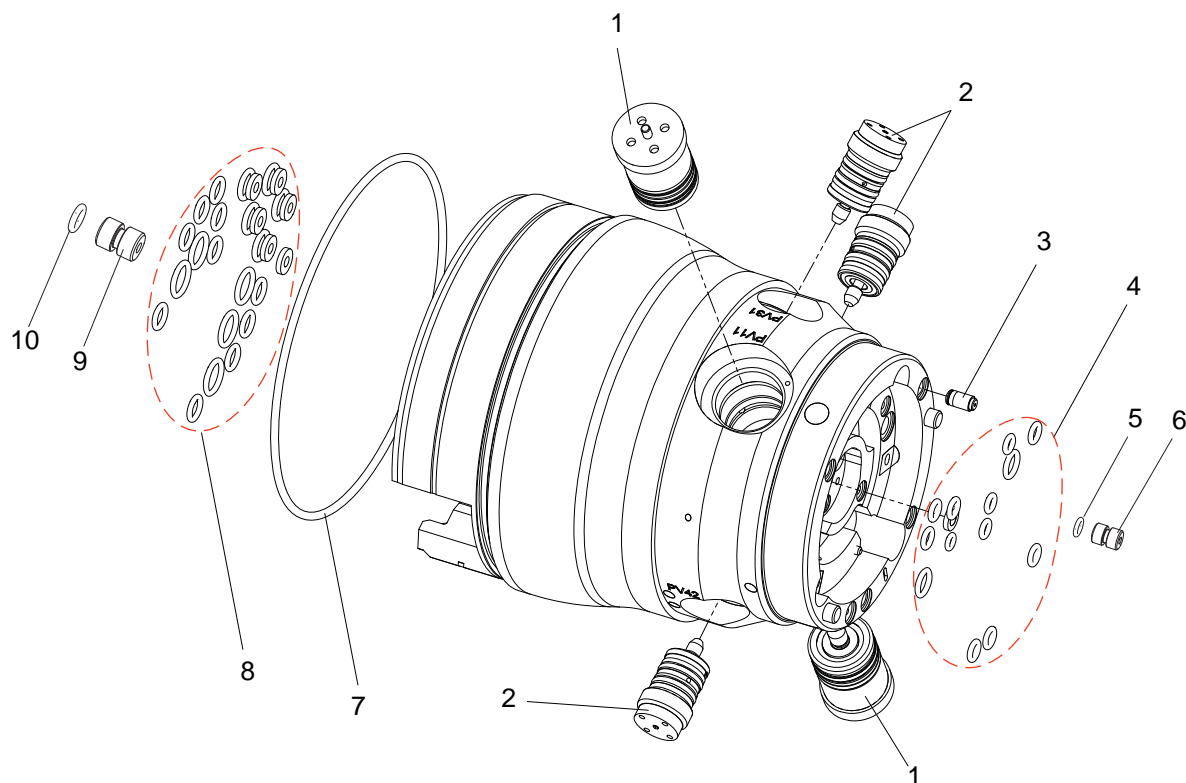

DES05130

Item	P/N	Description	Qty	Unit of sale	Maintenance level for spare part (*)
	910005623SAV	Body assembly	1	1	3
1	1507375	Microvalve, orange indicator, chemically inert o-rings (see RT Nr 6021)	2	1	1
2	1510004	Nanovalve, orange indicator, chemically inert o-rings (see RT Nr 6258)	3	1	1
3	910000369	Solvent pipette	1	1	1
4	910003415	O-ring kit (high speed turbine side) (see § 7.1.1.1 page 45)	1	1	1
5	J3STKL005	O-ring - chemically inert	1	1	1
6	900003305	Optical fiber plug, high speed turbine side	1	1	1
7	J2FENV694	O-ring - FEP	1	1	1
8	910003416	O-ring kit (quick disconnect plate side) (see § 7.1.1.2 page 46)	1	1	1
9	900003304	Optical fiber plug, quick disconnect plate side	1	1	1
10	J3STKL121	O-ring - chemically inert	1	1	1

(*)

Level 1: Standard preventive maintenance

Level 2: Corrective maintenance

Level 3: Exceptional maintenance

7.1.1.1. O-ring kit (high speed turbine side)

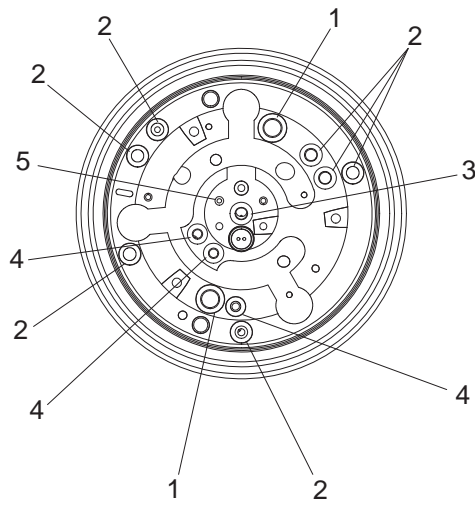

Item	P/N	Description	Qty	Unit of sale	Maintenance level for spare part (*)
	910003415	O-ring kit (high-speed turbine side)	1	1	1
1	J3STKL082	O-ring (chemically inert)	2	1	1
2	J3STKL046	O-ring (chemically inert)	7	1	1
3	160000028	Flat seal	1	1	1
4	J3STKL035	O-ring (chemically inert)	3	1	1
5	J3STKL002	O-ring (chemically inert)	1	1	1

(*)

Level 1: Standard preventive maintenance

Level 2: Corrective maintenance

Level 3: Exceptional maintenance

7.1.1.2. O-ring kit (quick disconnect plate side)

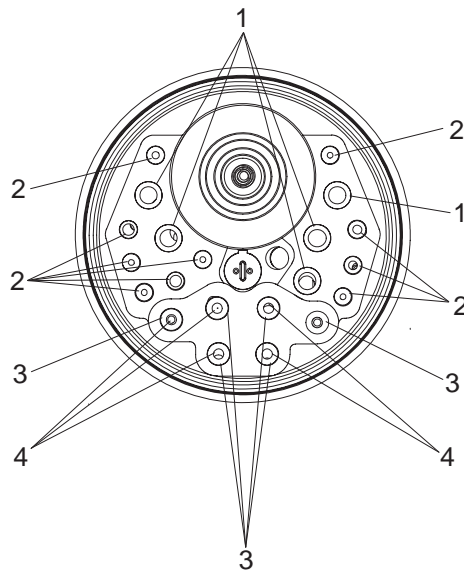

DES05330

Item	P/N	Description	Qty	Unit of sale	Maintenance level for spare part (*)
	910003416	O-ring kit (quick disconnect plate side)	1	1	1
1	J3STKL121	O-ring (chemically inert)	5	1	1
2	J3STKL078	O-ring (chemically inert)	10	1	1
3	160000027	Flat seal	6	1	1
4	J3STKL094	O-ring (chemically inert)	5	1	1

(*)

Level 1: Standard preventive maintenance

Level 2: Corrective maintenance

Level 3: Exceptional maintenance

7.1.2. PPH 707 ICWB M body with optical fiber

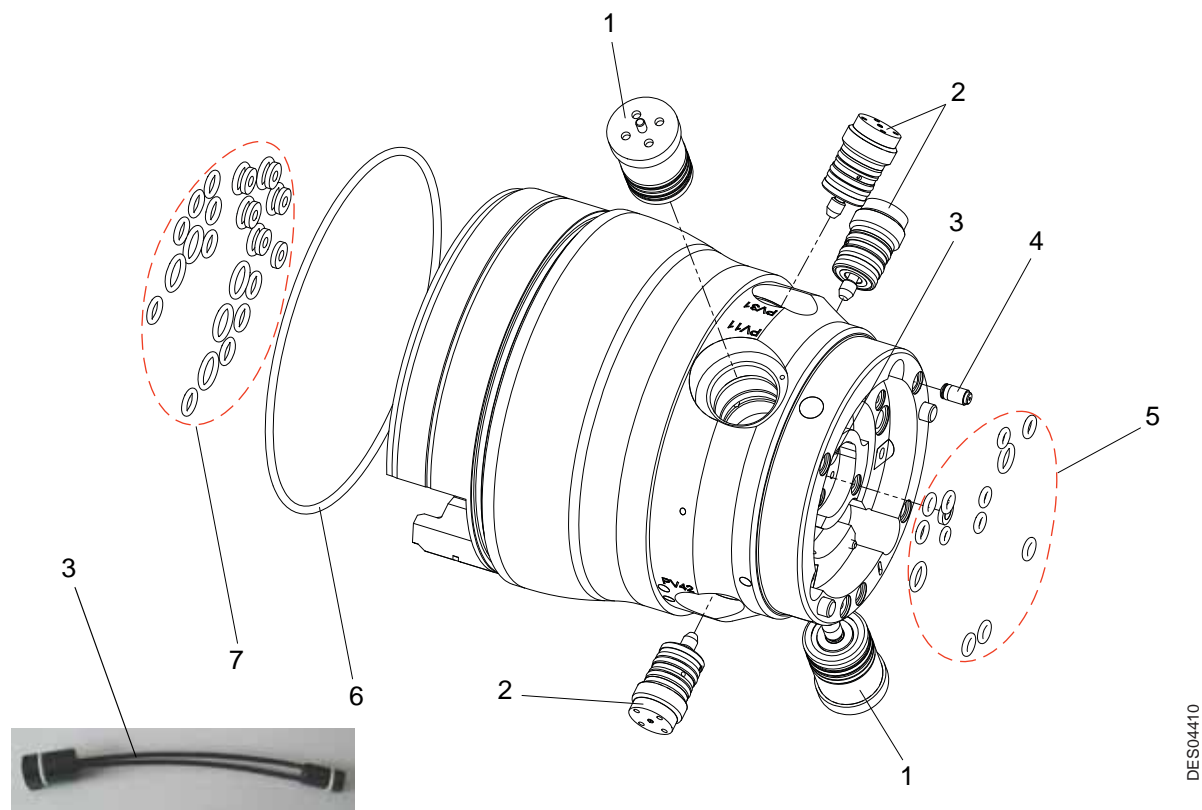

DES04410

Item	P/N	Description	Qty	Unit of sale	Maintenance level for spare part (*)
	910005623FOSAV	Body assembly with optical fiber	1	1	3
1	1507375	Microvalve, orange indicator, chemically inert o-rings (see RT Nr 6021)	2	1	1
2	1510004	Nanovalve, orange indicator, chemically inert o-rings (see RT Nr 6258)	3	1	1
3	910005174	Optical fiber set	1	1	1
4	910000369	Solvent pipette	1	1	1
5	910003415	O-ring kit (high speed turbine side) (see § 7.1.1.1 page 45)	1	1	1
6	J2FENV694	O-ring - FEP	1	1	1
7	910003416	O-ring kit (quick disconnect plate side) (see § 7.1.1.2 page 46)	1	1	1

(*)

Level 1: Standard preventive maintenance

Level 2: Corrective maintenance

Level 3: Exceptional maintenance

7.1.3. Injector / injector holder assembly

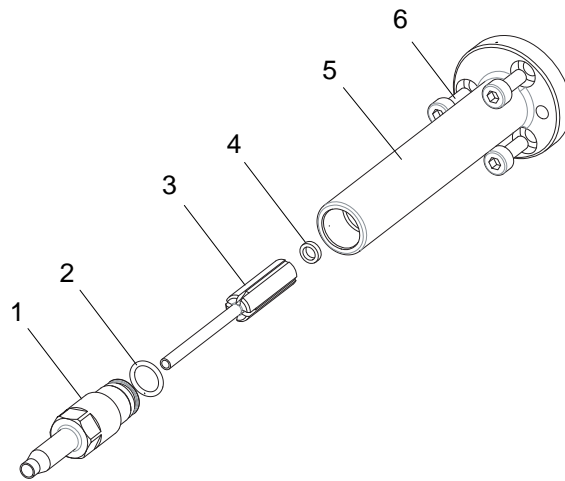

DES03195

Item	P/N	Description	Qty	Unit of sale	Maintenance level for spare part (*)
	910000618	Injector / injector holder assembly	1	1	3
1	900000159	Diffuser	1	1	1
2	J3STKL069	O-ring (chemically inert)	1	1	1
3	900000158	Slot Injector (dia. 1.8)	1	1	1
4	900010925	Flat seal - PEHD	1	1	1
5	900000157	High-speed turbine injector holder	1	1	3
6	X4FVSY066	C M3x 8 screw (stainless steel)	3	1	1

(*)

Level 1: Standard preventive maintenance

Level 2: Corrective maintenance

Level 3: Exceptional maintenance

7.2. Quick-disconnect plate assembly

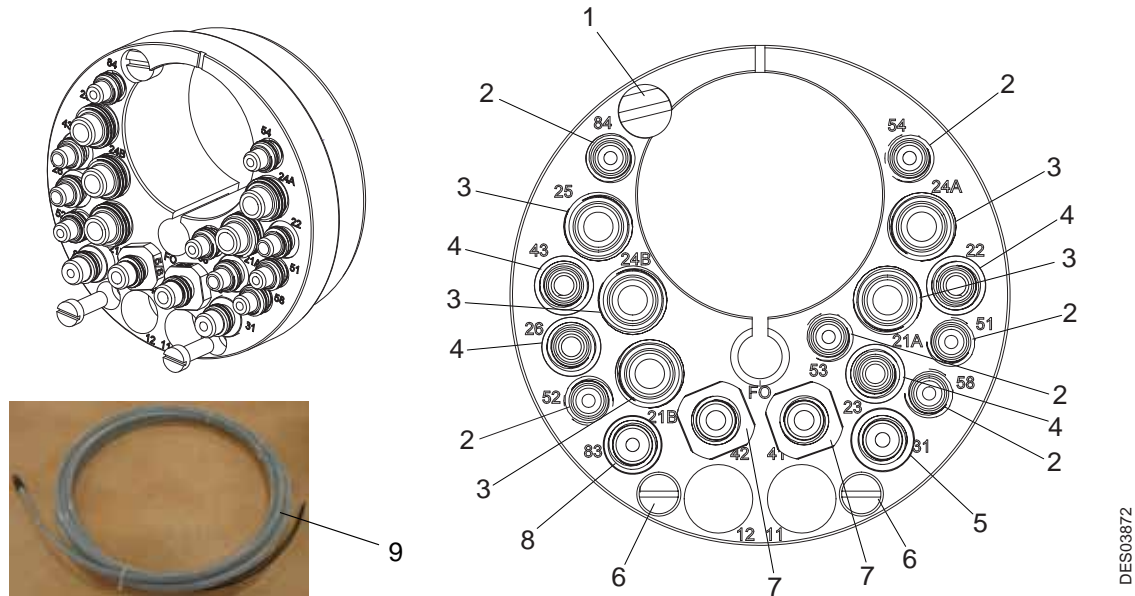

Item	P/N	Description	Qty	Unit of sale	Maintenance level for spare part (*)
	910003409	Quick disconnect plate assembly	1	1	3
1	900003914	High voltage unit locking screw	1	1	1
2	910002946	2.7/4 air fitting	6	1	1
3	910002948	6/8 air fitting	5	1	1
4	910002947	4/6 air fitting	4	1	1
5	910003413	3/6 product fitting	1	1	1
6	X9SVCB183	C M 5 x 15 screw (fiber-glass nylon)	2	1	1
7	910003345	5/8 anti rotation fitting	2	1	1
8	910004923	2.7/4 product fitting (screwed)	1	1	1
Option					
9	910005172	Optical fiber set, length 8 m	1	1	1

(*) Level 1: Standard preventive maintenance

Level 2: Corrective maintenance

Level 3: Exceptional maintenance

Position of fittings:

Item	Location	
2	51, 52, 53, 54, 58 and 84	When the quick disconnect plate (P/N # 910003409) is purchased, it is imperative to order fittings (P/N # 910003344) to replace the initial fittings (P/N # 910003345) on the 41 and 42 dumps.
3	21A, 21B, 24A, 24B and 25	
4	22, 23, 26 and 43	
5	31	
7	41 and 42	
8	83	

7.3. High voltage connection

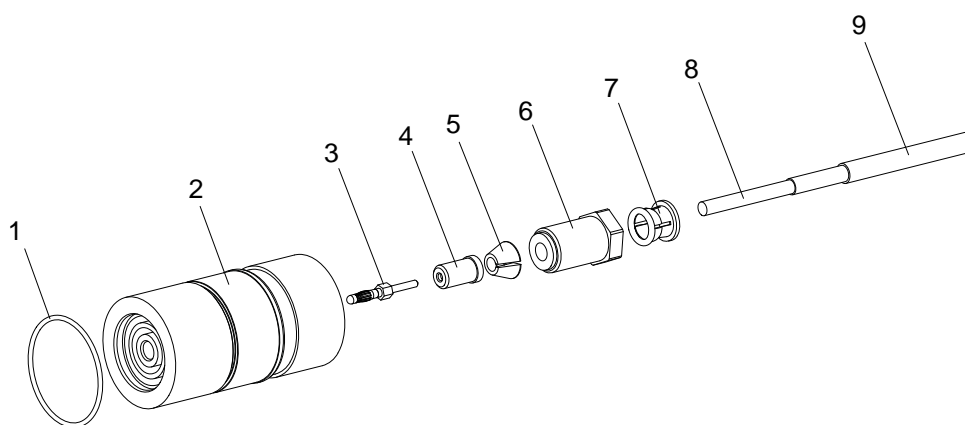

DES04180

Item	P/N	Description	Qty	Unit of sale	Maintenance level for spare part (*)
	910009188	High voltage connection	1	1	3
1	J2FENV445	O-ring - FEP viton	1	1	1
2	900004330	Plug	1	1	3
3	E4CSHT181	Banana plug	1	1	3
4	1411690	Sleeve, 100kV cable end	1	1	3
5	1411689	Split cone	1	1	3
6	1315058	Nut, grip holder	1	1	3
7	F6RXZG085	Stainless steel grip+seal	1	1	3
8	E2DAVD101	100kV high voltage cable	18 m	m	1
9	U1CBBR057	Protective tubing, HV cable, Dia.:10/12 colorless polyamide	18 m	m	1
	910009044	Set of ground connection for cable shielding	-	1	-

(*)

Level 1: Standard preventive maintenance

Level 2: Corrective maintenance

Level 3: Exceptional maintenance

Nota: The cable is delivered prepared at its two ends according to the high voltage unit and to the atomizer.

For the installation described in paragraph 1.4.1, it is necessary to cut the cable to the correct plate according to the installation (adjustment of the distances between HVU / insulating table and HVU / atomizer) and prepare the two ends so obtained according to the method described ([see § 6.3.10.1 page 39](#) step 1) by adapting the stripped lengths so as to:

- ensure a mini distance of 335 mm mini between the shielding and any part with high voltage.
- ensure the ground connection of the shielding of the connecting cable HVU / insulating table at the exit of the cage using the set (P/N # 910009044).

Note: For any length request higher than 18 m, contact Sames Technologies.

7.4. PPH 707 ICWB M support assembly

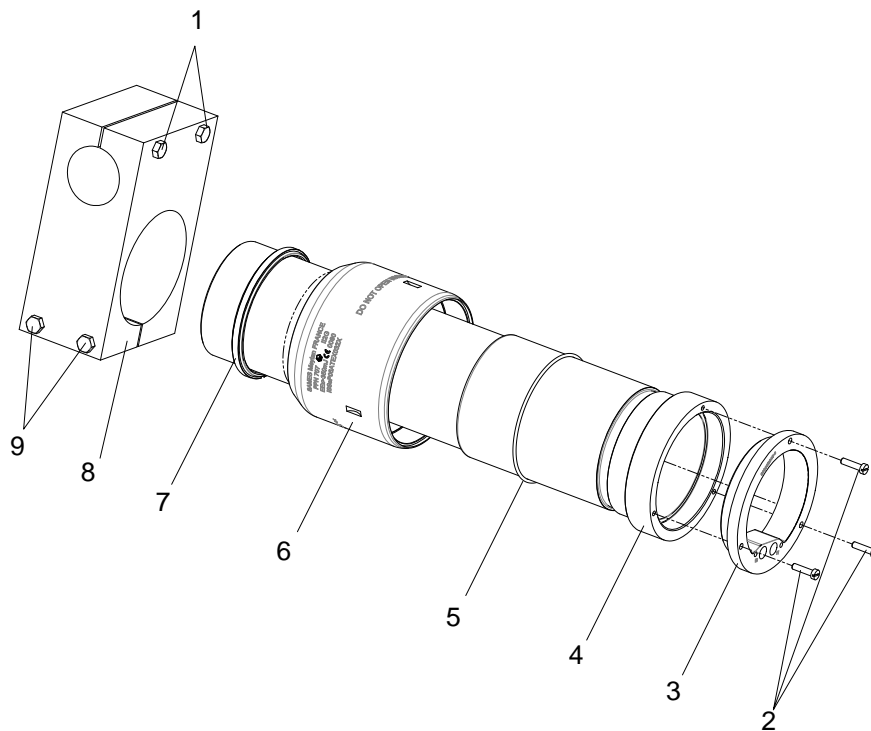

DES04818

Item	P/N	Description	Qty	Unit of sale	Maintenance level for spare part (*)
	910009076	PPH 707 ICWB M support assembly	1	1	3
1	X2BVHA291	H M8 x 60 zinc plated screw	2	1	3
2	X9SVCB186	C M5x 20 screw (fiber-glass nylon)	3	1	1
3	900006548	Quick disconnect plate support	1	1	3
4	900006550	PPH 707 ICWB M support tube	1	1	3
5	J2FENV665	O-ring - FEP viton	1	1	1
6	910012906	PPH 707 ICWB M nut	1	1	3
7	900006547	Split ring	1	1	1
8	821773	Nut for tube D: 100/50	1	1	3
9	X2BVHA295	H M8 x 80 zinc plated screw	2	1	3

(*)

Level 1: Standard preventive maintenance

Level 2: Corrective maintenance

Level 3: Exceptional maintenance