



DOCUMENTATION - DOKUMENTATION - DOCUMENTACIÓN

**MACHINE DE DOSAGE ELECTRONIQUE / ELECTRONIC MIXING MACHINE /
ELEKTRONISCHE 2-K ANKLAGE / MÁQUINA DE DOSIFICACIÓN ELECTRÓNICA**

PU 3000

4L 53/1

Notice / Manual / Betriebsanleitung / Libro : 582.005.110 - 1605

Date / Datum / Fecha : 27/05/16

Annule / Supersede / Ersetzt / Anula :

Modif. / Änderung :

**NOTICE ORIGINALE / TRANSLATION FROM THE ORIGINAL MANUAL
/ ÜBERSETZUNG DER ORIGINAL BETRIEBSANLEITUNG
/ TRADUCCIÓN DEL MANUAL ORIGINAL**

IMPORTANT : Lire attentivement tous les documents avant le stockage, l'installation ou la mise en service du matériel concerné (à usage strictement professionnel).

Before assembly and start-up, please read and clearly understand all the documents relating to this equipment (professional use only).

WICHTIGER HINWEIS: Vor Lagerung, Installation oder Inbetriebnahme des Geräts bitte sämtliche Dokumente sorgfältig lesen (Einsatz nur von geschultem Personal).

IMPORTANTE : Lea con atención todos los documentos antes de almacenar, instalar o poner en marcha el equipo (uso exclusivamente profesional).

PHOTOS ET ILLUSTRATIONS NON CONTRACTUELLES. MATERIELS SUJETS A MODIFICATION(S) SANS PREAVIS.

THE PICTURES AND DRAWINGS ARE NON CONTRACTUAL. WE RESERVE THE RIGHT TO MAKE CHANGES WITHOUT PRIOR NOTICE.

ALLE IN DIESEM DOKUMENT ENTHALTENEN SCHRIFTLICHEN ANGABEN UND ABBILDUNGEN STELLEN DIE NEUESTEN

PRODUKTINFORMATIONEN DAR. WIR BEHALTEN UNS DAS RECHT VOR, JEDERZEIT OHNE VORANKÜNDIGUNG ÄNDERUNGEN VORZUNEHMEN.

LAS FOTOGRAFÍAS E ILUSTRACIONES NO SON VINCULANTES. LOS MATERIALES ESTÁN SUJETOS A CAMBIOS SIN PREVIO AVISO.

KREMLIN - REXSON

150, avenue de Stalingrad

93 245 - STAINS CEDEX - France

☎ : 33 (0)1 49 40 25 25 Fax : 33 (0)1 48 26 07 16

www.kremlin-rexson.com



<p align="center">FR</p> <p>Pour une utilisation sûre, il est de votre responsabilité de :</p> <ul style="list-style-type: none"> • Lire attentivement tous les documents contenus dans le CD joint avant la mise en service de l'équipement, • D'installer, d'utiliser, d'entretenir et de réparer l'équipement conformément aux préconisations de KREMLIN REXSON ainsi qu'aux réglementations nationales et/ou locales, • Vous assurez que les utilisateurs de cet équipement ont été formés, ont parfaitement compris les règles de sécurité et qu'ils les appliquent. 	<p align="center">UK</p> <p>To ensure safe use of the machinery, it is your responsibility to:</p> <ul style="list-style-type: none"> • Carefully read all documents contained on the enclosed CD before putting the machinery into service, • Install, use, maintain and repair the machinery in accordance with KREMLIN REXSON's recommendations and national and/or local regulations, • Make sure that the users of the machinery have received proper training and that they have perfectly understood the safety rules and apply them. 	<p align="center">DE</p> <p>Eine sichere Nutzung setzt voraus, dass Sie: :</p> <ul style="list-style-type: none"> • alle in der CD enthaltenen Dokumente vor der Inbetriebnahme der Anlage aufmerksam lesen, • die Anlage im Einklang mit den Empfehlungen von KREMLIN REXSON sowie mit den nationalen und/oder lokalen Bestimmungen installieren, verwenden, warten und reparieren, • sich vergewissern, dass die Nutzer dieser Anlage angemessen geschult wurden, die Sicherheitsbestimmungen verstanden haben und sie anwenden.
<p align="center">ES</p> <p>Para una utilización segura, será de su responsabilidad:</p> <ul style="list-style-type: none"> • leer atentamente todos los documentos que se incluyen en el CD adjunto antes de la puesta en servicio del equipo, • instalar, utilizar, efectuar el mantenimiento y reparar el equipo con arreglo a las recomendaciones de KREMLIN REXSON y a la normativa nacional y/o local, • cerciorarse de que los usuarios de este equipo han recibido la formación necesaria, han entendido perfectamente las normas de seguridad y las aplican. 	<p align="center">IT</p> <p>Per un uso sicuro, vi invitiamo a:</p> <ul style="list-style-type: none"> • leggere attentamente tutta la documentazione contenuta nel CD allegato prima della messa in funzione dell'apparecchio, • installare, utilizzare, mantenere e riparare l'apparecchio rispettando le raccomandazioni di KREMLIN REXSON, nonché le normative nazionali e/o locali, • accertarvi che gli utilizzatori dell'apparecchio abbiano ricevuto adeguata formazione, abbiano perfettamente compreso le regole di sicurezza e le applichino. 	<p align="center">PT</p> <p>Para uma utilização segura, é da sua responsabilidade:</p> <ul style="list-style-type: none"> • Ler atentamente todos os documentos incluídos no CD em anexo antes de pôr o equipamento em funcionamento, • Proceder à instalação, utilização, manutenção e reparação do equipamento de acordo com as preconizações de KREMLIN REXSON, bem como com outros regulamentos nacionais e/ou locais aplicáveis, • Assegurar-se que os utilizadores do equipamento foram devidamente capacitados, compreenderam perfeitamente e aplicam as devidas regras de segurança.
<p align="center">NL</p> <p>Voor een veilig gebruik dient u:</p> <ul style="list-style-type: none"> • alle document op de bijgevoegde cd aandachtig te lezen alvorens het apparaat in werking te stellen, • het apparaat te installeren, gebruiken, onderhouden en repareren volgens de door KREMLIN REXSON gegeven aanbevelingen en overeenkomstig de nationale en/of plaatselijke reglementeringen, • zeker te stellen dat de gebruikers van dit apparaat zijn opgeleid, de veiligheidsregels perfect hebben begrepen en dat zij die ook toepassen. 	<p align="center">SE</p> <p>För en säker användning av utrustningen ansvarar ni för följande:</p> <ul style="list-style-type: none"> • Läs noga samtliga dokument som finns på den medföljande cd-skivan innan utrustningen tas i drift. • Installera, använd, underhåll och reparera utrustningen enligt anvisningarna från KREMLIN REXSON och enligt nationella och/eller lokala bestämmelser. • Försäkra er om att användare av denna utrustning erhållit utbildning, till fullo förstått säkerhetsföreskrifterna och tillämpar dem. 	<p align="center">FI</p> <p>Käytön turvallisuuden varmistamiseksi velvollisuutesi on:</p> <ul style="list-style-type: none"> • Lukea huolella kaikki CD:llä olevat asiakirjat ennen laitteiston käyttöönottoa, • Noudattaa laitteiston asennuksessa, käytössä, kunnossapidossa ja huollossa KREMLIN REXSON in suosituksia sekä kansallisia ja/tai paikallisia määräyksiä, • Varmistaa, että laitteiston käyttäjät ovat koulutettuja ja ymmärtävät täysin turvallisuusmääräykset ja miten niitä sovelletaan.
<p align="center">PL</p> <p>Dla zapewnienia bezpiecznego użytkowania na użytkownika spoczywa obowiązek:</p> <ul style="list-style-type: none"> • Uważnego zapoznania się ze wszystkimi dokumentami znajdującymi się na załączonej płycie CD przed pierwszym uruchomieniem urządzenia, • Instalowania, użytkowania, konserwacji i naprawy urządzenia zgodnie z zaleceniami firmy KREMLIN REXSON oraz z przepisami miejscowymi, • Upewnienia, że wszyscy przeszkoleni użytkownicy urządzenia zrozumieli zasady bezpieczeństwa i stosują się do nich. 	<p align="center">CS</p> <p>Pro bezpečné používání jste povinni:</p> <ul style="list-style-type: none"> • Před uvedením zařízení do provozu si pozorně přečíst veškeré dokumenty obsažené na příloženém CD, • Nainstalovat, používat, udržovat a opravovat zařízení v souladu s pokyny firmy KREMLIN REXSON a s národními a/nebo místními legislativními předpisy, • Ujistit se, že uživatelé tohoto zařízení byli vyškoleni, že dokonale pochopili bezpečnostní pravidla a že je dodržují. 	<p align="center">RU</p> <p>Для целей безопасного использования необходимо:</p> <ul style="list-style-type: none"> • Ознакомиться со всеми документами, содержащимися в прилагаемом компакт-диске до ввода оборудования в эксплуатацию; • Устанавливать, использовать, производить техническое обслуживание и ремонт оборудования в соответствии с рекомендациями KREMLIN REXSON и национальным и/или местным законодательством; • Убедиться, что пользователи настоящего оборудования прошли подготовку, надлежащим образом усвоили правила безопасности и обеспечивают их соблюдение.

Déclaration(s) de conformité au verso de ce document / Declaration(s) of conformity at the back of this document / Konformitätserklärung(en) auf der Rückseite dieser Unterlage / Declaración (es) de conformidad en el reverso de este documento / Dichiarazione/i di conformità sul retro del presente documento / Declaração(ões) de conformidade no verso do documento / Conformiteitsverklaring(en) op de keerzijde van dit document / Försäkran om överensstämmelse på omstående sida av detta dokument / Vaatimustenmukaisuusvakuutukset tämän asiakirjan kääntöpuolella / Deklaracja(e) zgodności na odwrocie dokumentu / Prohlášení o shodě se nachází/nacházejí na zadní straně tohoto dokumentu / Сертификат(ы) соответствия расположены на оборотной стороне настоящего документа

DECLARATION D'INCORPORATION
DECLARATION OF INCORPORATION
EINBAUERKLÄRUNG
DECLARACIÓN DE INCORPORACIÓN
DICHIARAZIONE DI INCORPORAZIONE
DECLARAÇÃO DE INCORPORAÇÃO
INBOUWVERKLARING
FÖRSÄKRAN FÖR INBYGGNAD
DEKLARACJA WŁĄCZENIA
PROHLÁŠENÍ O ZAČLENĚNÍ
ДЕКЛАРАЦИЯ О СООТВЕТСТВИИ
КОМПЛЕКТУЮЩИХ ИЗДЕЛИЙ

Le fabricant / The manufacturer / Der Hersteller / El fabricante / Il produttore / O fabricante / De fabrikant / Tillverkare / Valmistaja / Producent / Výrobce / Изготовитель:	KREMLIN REXSON 150, avenue de Stalingrad 93 240 - STAINS - FRANCE Tél. 33 (0)1 49 40 25 25 - Fax : 33 (0)1 48 26 07 16
--	--

Déclare que le matériel désigné ci-après / Herewith declares that the equipment / erklärt hiermit, dass die / Declara que el material designado a continuación / Dichiaro che il materiale sottoindicato / Declara que o material a seguir designado / verklaart dat de hieronder aangeduide apparatuur / Kungör att den utrustning som anges här nedan / ilmoittaa, että alla mainitut laitteistot / Oświadcza, że wymienione poniżej urządzenia / Prohlašuje, že níže uvedené vybavení / Декларирует, что ниженазванное оборудование:

MACHINE DE DOSAGE BI-COMPOSANT / TWO-COMPONENT PROPORTIONING MACHINE
ELEKTRONISCHE 2-K- ANLAGE / MÁQUINA DE DOSIFICACIÓN DOS COMPONENTES

PU 3000

Est conforme à la législation d'harmonisation de l'Union applicable suivante / Is in conformity with the relevant Union harmonisation legislation / Erfüllt die einschlägigen Harmonisierungsrechtsvorschriften der Union / es conforme con la legislación de armonización pertinente de la Unión / è conforme alla pertinente normativa di armonizzazione dell'Unione / in overeenstemming met de desbetteffende harmonisatiewetgeving van de Unie / med den relevanta harmoniserade unionslagstiftningen / on asiaa koskevan unionin yhdenmukaistamislainsäädännön vaatimusten mukainen / jest zgodny z odpowiednimi wymaganiami unijnego prawodawstwa harmonizacyjnego / Shoduje se s následující příslušnou evropskou harmonizační legislativou / Соответствует следующим стандартизированным нормам Союза.

Cette quasi-machine ne doit pas être mise en service avant que la machine finale dans laquelle elle doit être incorporée ait été déclarée conforme à la directive Machines 98/37/CE / This partly completed machinery must not be put into service until the final machinery in which it is to be incorporated has been declared in conformity with Directive 98/37/CE on Machinery / Die unvollständige Maschine darf erst in Betrieb genommen werden, wenn für die fertige Maschine, in die sie eingebaut werden soll, eine Konformitätserklärung mit der Maschinenrichtlinie 98/37/CE vorliegt / Esta quasi máquina no deberá ser puesta en servicio mientras la máquina final en la cual vaya a ser incorporada no haya sido declarada conforme a la Directiva 98/37/CE relativa a las máquinas / Questa quasi-macchina non deve essere messa in servizio finché la macchina finale in cui deve essere incorporata non è stata dichiarata conforme alla direttiva macchine 98/37/CE / Esta quase-máquina só deve ser posta em funcionamento quando a máquina final na qual deve ser incorporada tiver sido declarada em conformidade com as disposições pertinentes do anexo I da Directiva 98/37/CE relativa às Máquinas / Deze niet voltooide machine mag niet in dienst worden genomen voordat de afgewerkte machine, waarin zij moet worden ingebouwd, conform is verklaard aan de Machinerichtlijn 98/37/CE / Denna delvis fullbordade maskin får inte tas i drift innan den slutliga maskin i vilken den ska byggas in försäkrats överensstämma med maskindirektivet, 98/37/CE / Tätä puolivalmistetta ei saa ottaa käyttöön ennen kuin lopullisen koneen, johon se on määrä liittää, on ilmoitettu olevan konedirektiivin 98/37/EY mukainen / Niniejszej maszyny nieukończonyj nie można uruchomić bez uzyskania deklaracji zgodności z dyrektywą Maszynową 98/37/WE dla maszyny, której ma być częścią. / Toto neúplné strojní zařízení nesmí být uvedeno do provozu, dokud nebude strojní zařízení, do kterého je začleňováno, prohlášeno za shodné podle Směrnice 98/37/ES o strojních zařízeních / Настоящее незавершенное машинное устройство не может быть введено в эксплуатацию до тех пор, пока окончательная сборка машинного устройства, чью часть она составляет, не будет соответствовать Директиве 98/37/ЕС по безопасности машинного оборудования.

Dominique LAGOUGE

Directeur Général / Chief Executive Officer / Generaldirektor
/ Director General / Direttore Generale / Director Geral / Algemeen
Directeur / Generaldirektör / Pääjohtaja / Dyrektor Naczelny
/ Dyrektor Generalny / Generální ředitel / Генеральный директор

Fait à Stains, le / Established in Stains, on / Geschehen zu Stains, am / En Stains, a / Redatto a Stains, / Vastgesteld te Stains, / Utformat i Stains, den / Stains, Ranska, / Sporządzono w Stains, dnia / Stains, dnia / Издано в г. Стен (Stains) 20/04/2016 - 04/20/2016



**DECLARATION UE DE CONFORMITE
UE DECLARATION OF CONFORMITY
EU- KONFORMITÄTSEKTLÄRUNG
DECLARACIÓN UE DE CONFORMIDAD
DICHIARAZIONE DI CONFORMITÀ UE
DECLARAÇÃO UE DE CONFORMIDADE
EU-CONFORMITEITSVERKLARING
EU-FÖRSÄKRAN OM ÖVERENSSTÄMMELE
EU- VAATIMUKSEN MUKAISUUSVAKUUTUS
DEKLARACJA ZGODNOŚCI UE
EU PROHLÁŠENÍ O SHODĚ
ДЕКЛАРАЦИЯ О СООТВЕТСТВИИ НОРМАМ ЕС**



Le fabricant / The manufacturer / Der Hersteller / El fabricante / Il produttore / O fabricante / De fabrikant / Tillverkare / Valmistaja / Producent / Výrobce / Изготовитель:	KREMLIN REXSON 150, avenue de Stalingrad 93 240 - STAINS - FRANCE Tél. 33 (0)1 49 40 25 25 - Fax : 33 (0)1 48 26 07 16
--	--

Déclare que le matériel désigné ci-après / Herewith declares that the equipment / erklärt hiermit, dass die / Declara que el material designado a continuación / Dichiaro che il materiale sottoindicato / Declara que o material a seguir designado / verklaart dat de hieronder aangeduide apparatuur / Kungör att den utrustning som anges här nedan / ilmoittaa, että alla mainitut laitteistot / Oświadczka, że wymienione poniżej urządzenia / Prohlašuje, že níže uvedené vybavení / Декларирует, что ниже названное оборудование:

**MACHINE DE DOSAGE BI-COMPOSANT / TWO-COMPONENT PROPORTIONING MACHINE
ELEKTRONISCHE 2-K- ANLAGE / MÁQUINA DE DOSIFICACIÓN DOS COMPONENTES**

PU 3000

Est conforme à la législation d'harmonisation de l'Union applicable suivante / Is in conformity with the relevant Union harmonisation legislation / Erfüllt die einschlägigen Harmonisierungsrechtsvorschriften der Union / es conforme con la legislación de armonización pertinente de la Unión / è conforme alla pertinente normativa di armonizzazione dell'Unione / in overeenstemming met de desbetreffende harmonisatiewetgeving van de Unie / med den relevanta harmoniserade unionslagstiftningen / on asiaa koskevan unionin yhdenmukaistamislainsäädännön vaatimusten mukainen / jest zgodny z odpowiednimi wymaganiami unijnego prawodawstwa harmonizacyjnego / Shoduje se s následující příslušnou evropskou harmonizační legislativou / Соответствует следующим стандартизированным нормам Союза

Directive Basse Tension / Low Voltage Directive / Niederspannung-Richtlinie / Directiva Baja Tensión / Direttiva Bassa Tensione / Directiva de Baixa Tensão / Richtlijn Laagspanning / Lågspänningsdirektivet / Pienjännitedirektiivi / Dyrektywa Niskonapięciowa / Směrnice Pro Nízké Napětí / ДИРЕКТИВА О НИЗКОВОЛЬТНОМ ОБОРУДОВАНИИ En 60204-1:2006 + A1:2009	2014/35/UE								
Directive Compatibilité Electromagnétique / Electromagnetic Compatibility Directive / Richtlinie Für Elektromagnetische Verträglichkeit / Directiva de Compatibilidad Electromagnética / Direttiva Compatibilita Elettromagnetica / Directiva relativa à Compatibilidade Eletromagnética / Richtlijn Elektromagnetische Compatibiliteit / Direktivet om Elektromagnetisk Kompatibilitet / EMC-direktivi / Dyrektywa Kompatybilności Elektromagnetycznej / Směrnice Pro Elektromagnetickou Kompatibilitu / ДИРЕКТИВА ОБ ЭЛЕКТРОМАГНИТНОЙ СОВМЕСТИМОСТИ EN 61000-6-2:2005 EN 61000-6-3:2007 + A1:2011	2014/30/UE								
Directive ATEX / ATEX Directive / ATEX Richtlinie / Directiva ATEX / Direttiva ATEX / Diretiva ATEX / ATEX-Richtlijn / ATEX-direktivet / ATEX-direktivi / Dyrektywa ATEX / Směrnice ATEX / Директива ATEX Marquage Coffret de commande / Marking control box :  II 2G [EEEx ia] IIA Marquage Platine produit / Marking fluid module :  II 2G IIA T3 Tous les composants électriques utilisés en zone 1 sont, individuellement conformes à la directive 2014/34/UE. Leur présence combinée au sein de l'assemblage ne met pas en évidence de risques supplémentaires entraînant une évaluation globale de type de la machine. / Each individual electrical component used in zone 1 is in conformity with the 2014/34/UE directive. Their combined presence in the assembly has not highlighted any additional risks that would necessitate a comprehensive assesment of this type of machinery.	2014/34/UE								
<table border="1"> <thead> <tr> <th>Matériel / Equipment</th> <th>N° d'agrément / Approval N°</th> </tr> </thead> <tbody> <tr> <td>Barrière Zener / Zener barrier</td> <td>BAS 01 ATEX 7005</td> </tr> <tr> <td>Electrovanne / Electrovalve ATEX</td> <td>LCIE 12 ATEX 3005 X</td> </tr> <tr> <td>Electrovanne / Electrovalve</td> <td>DEKRA 11 ATEX 0091 X</td> </tr> </tbody> </table>	Matériel / Equipment	N° d'agrément / Approval N°	Barrière Zener / Zener barrier	BAS 01 ATEX 7005	Electrovanne / Electrovalve ATEX	LCIE 12 ATEX 3005 X	Electrovanne / Electrovalve	DEKRA 11 ATEX 0091 X	
Matériel / Equipment	N° d'agrément / Approval N°								
Barrière Zener / Zener barrier	BAS 01 ATEX 7005								
Electrovanne / Electrovalve ATEX	LCIE 12 ATEX 3005 X								
Electrovanne / Electrovalve	DEKRA 11 ATEX 0091 X								

Dominique LAGOUGE

Directeur Général / Chief Executive Officer / Generaldirektor
/ Director General / Direttore Generale / Director Geral / Algemeen
Directeur / Generaldirektör / Pääjohtaja / Dyrektor Naczelny
/ Dyrektor Generalny / Generální ředitel / Генеральный директор

Fait à Stains, le / Established in Stains, on / Geschehen zu Stains, am / En Stains, a / Redatto a Stains, / Vastgesteld te Stains, / Utformat i Stains, den / Stains, Ranska, / Sporządzono w Stains, dnia / Stains, dnia / Издано в г. Стен (Stains) 20/04/2016 - 04/20/2016



INSTALLATION AND SAFETY INSTRUCTIONS

TRANSLATION OF THE ORIGINAL MANUAL

IMPORTANT : Before assembly and start-up, please read and clearly understand all the documents relating to this equipment (professional use only).

THE PICTURES AND DRAWINGS ARE NON CONTRACTUAL. WE RESERVE THE RIGHT TO MAKE CHANGES WITHOUT PRIOR NOTICE.

KREMLIN - REXSON

150, avenue de Stalingrad

93 245 - STAINS CEDEX – France

☎ : 33 (0)1 49 40 25 25 *Fax* : 33 (0)1 48 26 07 16

www.kremlin-rexson.com

1. SAFETY INSTRUCTIONS

GENERAL SAFETY INSTRUCTIONS



CAUTION : The equipment can be dangerous if you do not follow our instructions concerning installation and servicing described in this manual and in accordance with applicable European standards and local national safety regulations.

Please carefully read all the instruction literature before operating your equipment.

Only trained operators can use the equipment (To acquire an essential training, please contact the "KREMLIN REXSON University" training center - Stains).

The foreman must ensure that the operator has understood the safety instructions for this equipment as well as the instructions in the manuals for the different parts and accessories.

Read carefully all instruction manuals, label markings before operating the equipment.



















Incorrect use may result in injury. This equipment is for professional use only. It must be used only for what it has been designed for. Never modify the equipment. The parts and accessories supplied must be regularly inspected. Defective or worn parts must be replaced.

Guards (motor cover, coupling shields, connectors,...) have been designed for a safe use of the equipment.
The manufacturer will not be held responsible for bodily injury or failure and / or property damage due to destruction, the overshadowing or the partial or total removal of the guards.

Never exceed the equipment components' maximum working pressure.

Comply with regulations concerning safety, fire risks, electrical regulations in force in the country of final destination of the material. Use only products or solvent compatible with the parts in contact with the material (refer to data sheet of the material manufacturer).

PICTOGRAMS

					
NIP HAZARD	WARNING MOVING ELEVATOR	WARNING MOVING PARTS	WARNING MOVING SHOVEL	DO NOT EXCEED THIS PRESSURE	HIGH PRESSURE HAZARD
					
RELIEF OR DRAIN VALVE	WARNING HOSE UNDER PRESSURE	WEAR GLASSES OBLIGATORY	WEAR OF GLOVES IS OBLIGATORY	PRODUCT VAPOR HAZARDS	WARNING HOT PARTS OR AREAS
					
ELECTRICAL HAZARD	WARNING FIRE HAZARDS	EXPLOSION HAZARDS	GROUNDING	WARNING (USER)	WARNING SERIOUS INJURIES

FIRE - EXPLOSION - SPARKS - STATIC ELECTRICITY HAZARDS

A poor earth connection, inadequate ventilation, sparks or static electricity can cause an explosion or fire. to avoid these risks when using or servicing KREMLIN REXSON equipment, the following safety procedures must be followed :



- ensure a good earth connection and ground the parts to be handled i.e. solvents, materials, components and equipment,
- ensure adequate ventilation,
- keep working area clean and free from waste solvents, chemicals, or solid waste i.e. rags, paper and empty chemicals drums,
- never use electrical switches / power if in an atmosphere of volatile solvent vapour,
- stop working immediately in case of electrical arcs,
- never store chemicals and solvents in the working area.
- use paint whose flash point is the highest possible to prevent from any formation of gas and inflammable vapours (refer to materials' safety instructions),
- install a cover on the drums to reduce the diffusion of gas and vapours in the spraybooth.

TOXIC PRODUCT HAZARDS

Toxic products or vapours can cause severe injury not only through contact with the body, but also if the products are ingested or inhaled. It is imperative :



- to know the material products and their risks,
- notified or hazardous materials must be stored in accordance with the regulations,
- the material must be stored in an appropriate container, never place materials in a container where there is a risk of spillage or leakage,
- a procedure must be applied for the safe disposal of waste material. It must comply with all prevailing regulations and legislations of the country where the equipment is to be used,
- protective clothing should always be worn in compliance with the material manufacturers' recommendations,
- depending on the application and chemical safety instructions, safety glasses, hearing protective earplug, gloves, foot wear, protective masks and possible breathing equipment should be worn to comply with the regulations (Refer to chapter "Safety equipment of KREMLIN selection guide).



CAUTION!



It is forbidden to use material containing high concentrations of halogenated hydrocarbon solvents with **aluminium or zinc fillers** .Non-compliance with the instructions may cause explosion risk causing serious or fatal injury.

EQUIPMENT REQUIREMENTS

Guards (motor cover, coupling shields, connectors,...) have been designed for a safe use of the equipment.

The manufacturer will not be held responsible for bodily injury or failure and / or property damage due to destruction, the overshadowing or the partial or total removal of the guards.

PUMP



Before carrying out any work, it is imperative to read and clearly understand the disassembly and reassembly instructions before servicing. The operator must understand the equipment and the safety instructions. These instructions are available in the equipment manuals.



The air motor is designed to be mounted with a pump. Never modify any components or couplings. When operating, please keep hands away from moving parts. Before starting up the equipment, please read the PRESSURE RELIEF instructions. Please ensure that any relief or drain valves fitted are in good working order.

HOSES

- Keep hoses out of circulation areas, moving parts or hot surfaces,
- Never expose product hoses to temperature higher than + 60°C / 140° F or lower than 0°C / 32° F,
- Never pull or use the hoses to move the equipment,
- Tighten all fittings as well as the hoses before operating the equipment,
- Check the hoses regularly; change them if they are damaged,
- Never exceed the working pressure (WP) indicated on the hose.

USED PRODUCTS

Considering the wide variety of products that are available and can be used in our equipment it is impossible to check and make recommendations for all chemical data, regarding the risks of possible chemical attack and their long term chemical reaction

KREMLIN REXSON can not be held liable for :

- Compatibility of wetted parts,
- Risks to staff and the surroundings,
- for worn or defective parts, for faulty equipment or units, or the quality of final product.

It is the responsibility of the user to know and prevent any possible risks such as toxic vapours, fires or explosions. He shall determine the risks of immediate reactions or pursuant to repeated exposures of the staff,

KREMLIN REXSON shall not be liable for physical injuries, direct or indirect material damages caused by the use of chemicals.

2. HANDLING



Check the weight and the dimensions of the equipment

(☞ refer to 'Technical features' section of the instruction manual

If weight and dimensions are too important, the unloading must be carried out by means of a forklift or any other appropriate means with a qualified personnel and in a clear horizontal area to prevent from risks of damage injury or an accident.

The centre of gravity is not in the centre of the machine : carry out by hand a stability-test after having lifted the whole at 10 cm / 3.937" maximum.

After the unloading, the handling of the whole (eg: elevator pump) is carried out by means of a pallet truck taking the bottom part of the frame.

Remark : Each pump motor is fitted with a ring. The ring is designed for the hoisting of one pump and can not be used for the handling of the complete machine.

3. STORING

Storing before installation :

- Storing ambient temperature : 0 / +50 °C / 0 / +122°F
- Protect the whole against dust, water trickling, dampness and shocks.

Storing after installation :

- Operating temperature : +15 / +35 °C / +59 / +138.2° F
- Protect the whole against dust, water trickling, dampness and shocks.

4. INSTALLATION OF THE EQUIPMENT

The machine is installed on a stable horizontal floor (for eg a concrete flag).



To avoid risks caused by static electricity, the equipment as well as its components must be grounded.

- **For the pumping equipments** (pumps, pneumatic rams, frame...), a section wire of 2.5 mm² is fixed on the material. Use this wire to connect the material to "the general ground". In case of severe environments (mechanical protection of the wire of earthing insufficient, vibrations, mobile material...) where function damages at the ground are probable, the user have to replace the provided wire of 2.5 mm² by a device more adapted to its environment (wire with a more important section, bonding strip, fixing by thimble with eyelet...),

The continuity of the ground must be controlled by a qualified electrician. If the continuity of the ground is not ensured, check the terminal, the wire and the earthing point. **Never** use the material without have solved this problem.

- In the severe cases of environments (mechanical protection of the wire of earthing insufficient, vibrations, mobile material...) where damages of the function put at the ground are probable, the user will have to replace the wire of 2.5 mm² provided, by a device more adapted to its environment (wire of more important section, bonding strip, fixing by thimble with eyelet...),
- **The gun** must be 'grounded' via a material hose or an air hose. In case of spraying by means of a gun with cup, the air hose must be conductive,
- **The materials to be painted** must also be grounded.

All the materials situated in the working area shall be grounded.



- **Never store** more than necessary inflammable materials inside the working area,
- The materials must be stored into **approved drums** and grounded,
- Use only grounded **metals containers** for the use of cleaning solvents,
- **Cardboard and paper are prohibited.**

5. MARKING OF THE EQUIPMENT

Each equipment has a marking plate.

The plate consists of the name of the manufacturer, the equipment part number and important information for correct use of the equipment (air pressure, electric power,...).



INSTRUCTION MANUAL
ELECTRONIC MIXING MACHINE PU 3000

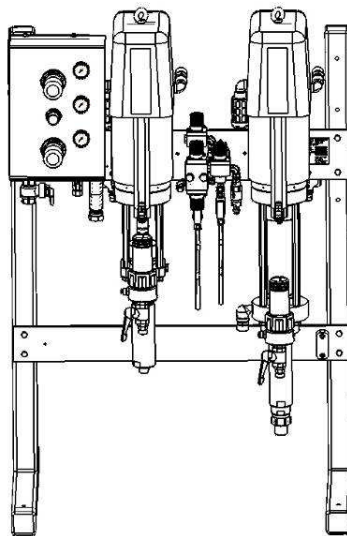

Manual : 1403 573.199.112

Date : 12/03/14 - Cancels : 13/12/13

Modif. : + PU 3000 4 L 30/1 & PU 3000 4 L 53/1, § 1, § 2 , § 4, § 5, § 8, § 9, § 11, § 12.

TRANSLATION FROM THE ORIGINAL MANUAL

IMPORTANT : Before assembly and start-up, please read and clearly understand all the documents relating to this equipment (professional use only).

THE PICTURES AND DRAWINGS ARE NON CONTRACTUAL. WE RESERVE THE RIGHT TO MAKE CHANGES WITHOUT PRIOR NOTICE.

KREMLIN - REXSON

150, avenue de Stalingrad
93 245 - STAINS CEDEX – France

☎ : 33 (0)1 49 40 25 25 Fax : 33 (0)1 48 26 07 16

www.kremlin-rexson.com



TABLE OF CONTENTS

1. SAFETY INSTRUCTIONS	6
■ SPECIFIC SAFETY INSTRUCTIONS	6
■ ENVIRONMENT.....	7
■ ELECTROSTATIC INSTALLATION	7
2. DESCRIPTION	8
3. OPERATING DESCRIPTION.....	10
4. FEATURES	10
5. INSTALLATION	11
■ HANDLING.....	11
■ STORAGE.....	11
■ ENVIRONMENT ON THE AREA.....	11
■ DESCRIPTION OF THE LABEL MARKINGS.....	12
■ INSTALLATION DIAGRAM.....	13
■ INSTALLATION	14
■ CONNECTION OF THE CONTROL BOX AND OF THE FLUID FRAME	15
6. OPERATING	16
■ DRIVING FROM THE MACHINE.....	16
■ SWITCHING ON THE MACHINE	16
7. FIRST SWITCHING ON	17
8. FIRST PLACING INTO OPERATION	18
■ BEFORE SWITCHING ON	18
■ FLUSHING OF THE PUMPS AND OF THE MACHINE IN SOLVENT	18
■ START UP OF THE MACHINE	19
■ MIXING RATIO CHECKING	19
9. APPLICATION PROGRAMMING (F3)	21
■ PASSWORD	21
■ PROCEDURE TO GET THE VERSION NUMBER OF THE ELECTRONIC CARD.....	21
■ PARAMETERS	22
■ VALIDATION OF THE INITIALIZATION MODE	23
■ PRODUCTION (F1)	24
■ FLUSHING (F2)	25
■ CONSUMPTIONS / PRINT (F4)	25
■ DOWNLOADING DATA FROM PU 3000 TO A COMPUTER.....	27
■ DRUM REPLACEMENT PROCEDURE	31

10. INDICATIONS OF OPERATION GIVEN BY THE MACHINE.....	32
■ INDICATIONS GIVEN BY THE LEDS	32
■ MESSAGES GIVEN BY THE DISPLAY UNIT	32
11. MAINTENANCE	33
■ SYNOPTIC.....	33
■ MAINTENANCE PLAN.....	34
■ TROUBLESHOOTING.....	35
■ DIAGNOSTICS	35
12. PROPORTION AND OUTPUT ACCORDING TO THE RATIO	37
■ PU 3000 PNEUMATIC, AIRMIX® AND AIRLESS VERSIONS	37
■ PU 3000 4 L 30/1 AND 4 L 53/1 VERSIONS.....	38
13. MIXING RATIO.....	39
14. PNEUMATIC AND ELECTRIC DIAGRAMS	39
15. FEATURES - PU 3000 PNEUMATIC.....	41
■ COMPOSITION	41
■ TECHNICAL FEATURES	41
■ SPECIFIC PARAMETERS.....	41
16. FEATURES - PU 3000 AIRMIX®.....	42
■ COMPOSITION	42
■ TECHNICAL FEATURES	42
■ SPECIFIC PARAMETERS.....	42
17. DISASSEMBLY & REASSEMBLY - PU 3000 PNEUMATIC, PU 3000 AIRMIX®	43
■ MIXER.....	43
■ PILOTED VALVES.....	43
■ FLUID SECTION, MODEL 50 (BASE) (REFER TO DOC. 573.080.050)	44
■ FLUID SECTION, MODEL 50 F (CATALYST) (REFER TO DOC. 573.114.050).....	46
18. FEATURES - PU 3000 AIRLESS.....	49
■ COMPOSITION	49
■ TECHNICAL FEATURES	49
■ SPECIFIC PARAMETERS.....	49
19. DISASSEMBLY & REASSEMBLY - PU 3000 AIRLESS	50
■ MIXER.....	50
■ ASI 40 VALVES (REFER TO DOC. 573.062.050).....	50
■ FLUID SECTION, MODEL ALTO 50CC (BASE & CATALYST) (REFER TO DOC. 573.395.050)	51

20. FEATURES - PU 3000 4 L 30/1	54
■ COMPOSITION	54
■ TECHNICAL FEATURES	54
■ SPECIFIC PARAMETERS.....	54
21. DISASSEMBLY & REASSEMBLY - PU 3000 4 L 30/1	55
■ MIXER.....	55
■ ASI 40 VALVES (REFER TO DOC. 573.062.050).....	55
■ FLUID SECTION, MODEL ALTO 225CC (BASE & CATALYST) (REFER TO DOC. 573.451.050)	56
22. FEATURES - PU 3000 4 L 53/1	59
■ COMPOSITION	59
■ TECHNICAL FEATURES	59
■ SPECIFIC PARAMETERS.....	59
23. DISASSEMBLY & REASSEMBLY - PU 3000 4 L 53/1	60
■ MIXER.....	60
■ ASI 40 VALVES (REFER TO DOC. 573.062.050).....	60
■ FLUID SECTION, MODEL MAJOR 227CC # 105 174 01 07 (BASE & CATALYST) (REFER TO DOC. 573.447.050)	61

ADDITIONAL DOCUMENTATIONS :

Incorporation declaration and EC declaration of conformity	578.013.130-UK
--	----------------

PU 3000 PNEUMATIC

	Spare Parts
PU 3000 Pneumatic Pump - Assembly	Doc. 573.404.050
Pneumatic motor, model 1500 (only for PU3000)	Doc. 573.437.050
BASE fluid section, model 50	Doc. 573.080.050
CATA fluid section, model 50 F	Doc. 573.114.050
Color changer and valve	Doc. 573.187.050 + Doc. 573.188.050
LP fluid regulator (Spring operated)	Doc. 573.203.110 + Doc. 573.415.050
HP fluid regulator, model 3/8 (260 bar / 3771 psi)	Doc. 573.299.050
Flushing pump, model EOS 02-C85	Doc. 573.457.050

PU 3000 AIRMIX®

	Spare Parts
PU 3000 Airmix Pump - Assembly	Doc. 573.386.050
Pneumatic motor, model 3000	Doc. 573.387.050
BASE fluid section, model 50	Doc. 573.080.050
CATA fluid section, model 50 F	Doc. 573.114.050
Color changer and valve	Doc. 573.187.050 + Doc. 573.188.050
Filter, model HP 3/8 (260 bar / 3770.8 psi)	Doc. 573.299.050
Flushing pump, model EOS 30-C25	Doc. 573.438.050

PU 3000 AIRLESS

	Spare Parts
PU 3000 Airless Pump - Assembly	Doc. 573.389.050
Pneumatic motor, model 5000	Doc. 573.390.050
BASE & CATA fluid section, model 50cc	Doc. 573.395.050
ASI 40 valve	Doc. 573.062.050
Filter, model HP 3/4 (360 bar / 5222 psi)	Doc. 573.327.050
Flushing pump, model EOS 30-C25	Doc. 573.438.050

PU 3000 4 L 30/1

	Spare Parts
PU 3000 4 L 30/1 PUMP - Assembly	Doc. 573.452.050
Pneumatic motor, Model 5000	Doc. 573.390.050
BASE & CATA fluid section, type 225cc	Doc. 573.451.050
ASI 40 valve	Doc. 573.062.050
Filter, model HP 3/4 (360 bar / 5222 psi)	Doc. 573.327.050
Flushing pump, model EOS 30-C25	Doc. 573.438.050

PU 3000 4 L 53/1

	Spare Parts
PU 3000 4 L 53/1 PUMP - Assembly	Doc. 573.453.050
Pneumatic motor, model 7000	Doc. 573.450.050
BASE & CATA fluid section, type 227cc	Doc. 573.447.050
ASI 40 valve	Doc. 573.062.050
Filter, model HP 3/4 (360 bar / 5222 psi)	Doc. 573.327.050
Flushing pump, model EOS 30-C25	Doc. 573.438.050

DIAGRAMS

Pneumatic and electric diagrams	055.680.031
---------------------------------	-------------

Dear Customer, You are the owner of our new PU 3000 mixing system and we would like to take this opportunity to thank you.

Special care has been taken during all designing and manufacturing process to make sure your investment will provide full satisfaction. Non-compliance with instructions and precautions stated in this manual could reduce the equipment working life, resulting in operating problems and create unsafe conditions.

1. SAFETY INSTRUCTIONS

■ GENERAL SAFETY INSTRUCTIONS



CAUTION : The equipment can be dangerous if you do not follow our instructions concerning installation and servicing described in this manual and in accordance with applicable European standards and local national safety regulations.

Please carefully read all the instruction literature before operating your equipment.

Only trained operators can use the equipment (To acquire an essential training, please contact the "KREMLIN REXSON University" training center - Stains).

The foreman must ensure that the operator has understood the safety instructions for this equipment as well as the instructions in the manuals for the different parts and accessories.

Read carefully all instruction manuals, label markings before operating the equipment.

Incorrect use may result in injury. This equipment is for professional use only. It must be used only for what it has been designed for. Never modify the equipment. The parts and accessories supplied must be regularly inspected. Defective or worn parts must be replaced.

Never exceed the equipment components' maximum working pressure.

Comply with regulations concerning safety, fire risks, electrical regulations in force in the country of final destination of the material. Use only products or solvent compatible with the parts in contact with the material (refer to data sheet of the material manufacturer).



**Refer to 'Installation and safety instructions' document
(doc. 578.001.130)**

■ SPECIFIC SAFETY INSTRUCTIONS



The control box of the PU 3000 mixing machine shall be installed outside the explosive area. It shall be installed in a safe area (non-explosive area according to the ATEX directive - refer § 5).



Do not install the paint drums underneath the pumps or the electric equipments. Place them in front of the frame. Install a cover on the drums to reduce the diffusion of gas and vapours in the booth.



Connect the control box to the mains supply fitted with a ground.

The fluid module is fitted with a ground. Connect the ground cable to earth.

Do not use any product or solvent incompatible with the machine components.

Use the appropriate solvent for the material being sprayed to increase the equipment working life.



Wear protective glasses to protect the operator from possible discharges during the handling of the machine.



CAUTION : To prevent from any formation of gas and inflammable vapours, use paint whose flash point is the highest possible (refer to materials' safety instructions).

Before cleaning or removing components of the equipment, it is compulsory :

- 1 - to shut off the air supply,
- 2 - to open the gun fluid circuit and depressurize the hoses,
- 3 - to switch off the machine electrical supply.

■ ENVIRONMENT

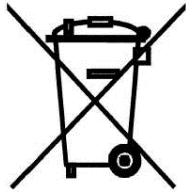

This equipment consists of a label plate with the name of the manufacturer, the equipment part number, the interesting informations to use correctly the equipment (pressure, voltage...) and the above pictogram.

The equipment is designed with and consists of high quality materials and components which can be re-used.

The 2002/96/EC European Directive covers all equipments with a crossed-out bin pictogram. Please inform yourself about the collection systems for electric and electronic equipments.

Please act in accordance with local rules and **do not dispose of old equipment with household wastes**. A correct disposal of old equipment will help prevent negative consequences for the environment and health.

■ ELECTROSTATIC INSTALLATION

It is better not to use the equipment with water-based paints.

For paints with a resistivity > 5Mohm, we recommend you to consult Kremlin Rexson in order to integrate properly the unit.

2. DESCRIPTION

The PU 3000 proportioning system is designed for applying two component solvent or water-based paints and lacquers.

There are three versions available :

- a pneumatic version (maximum pressure : 0-6 bar / 0-87 psi or 6-40 bar / 87-580 psi)
- an AIRMIX® version (maximum pressure : 180 bar / 2610 psi),
- an AIRLESS version (maximum pressure : 350 bar / 5076 psi),
- a 4 L 30/1 version (maximum pressure : 180 bar / 2610 psi),
- a 4 L 53/1 version (maximum pressure : 350 bar / 5076 psi).

It is under an independant form only supplied with compressed air (maximum 6 bar / 87 psi) and an electric supply (115V / 230V).

It consists of :

- a control box with PLC and electromagnetic control components,
- a frame supporting a BASE pump, a CATALYST pump, the automatic valves for the materials and the solvent, and electropneumatic control components.

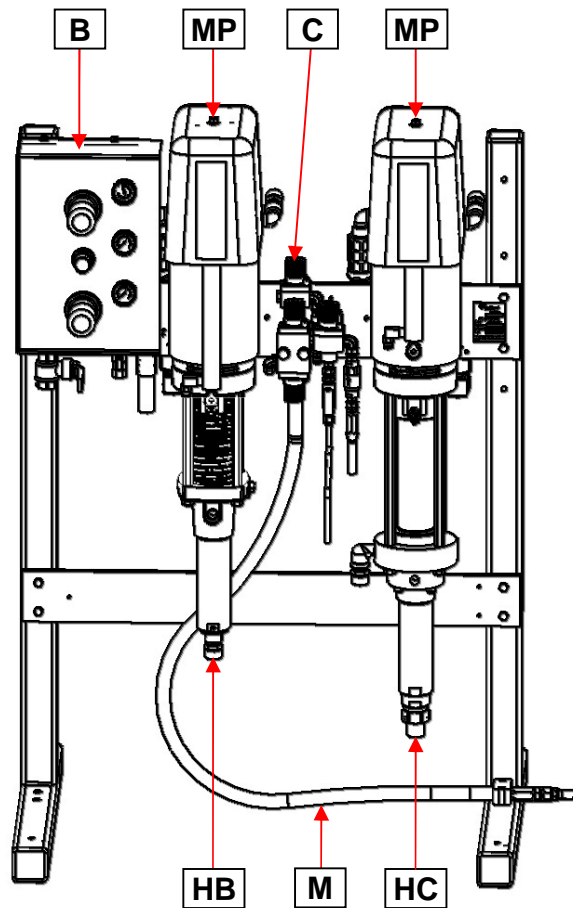
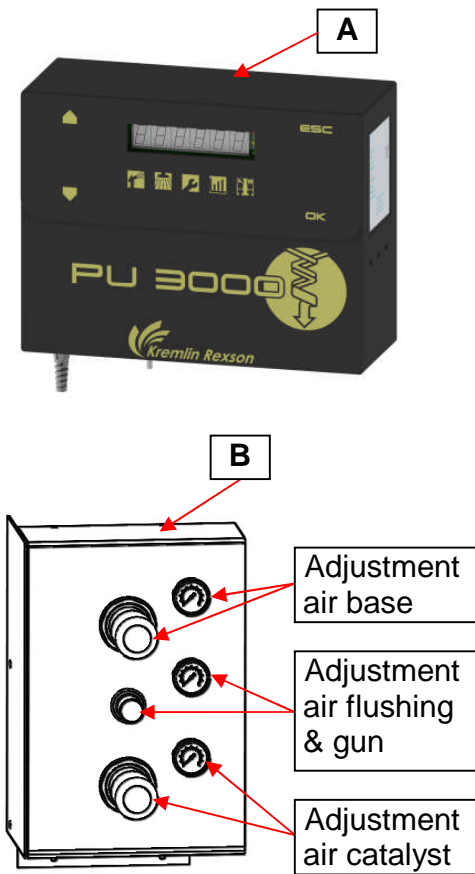

A : Electronic control box with display unit

B : Air equipment

C : Mixing unit

HB : BASE fluid section

HC : CATALYST fluid section

MP : Pneumatic motor

M : Mixer

Option : Flushing pump

Nota : drawing of a pump, unit PU 3000 Airmix®

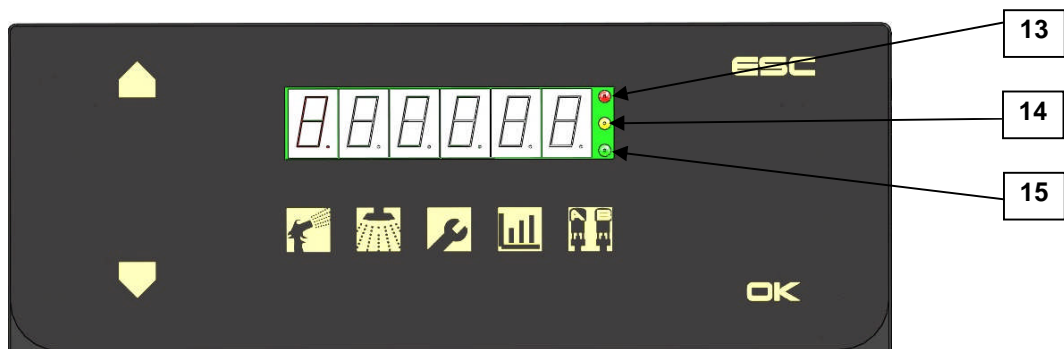

FRONT VIEW OF THE CONTROL BOX

Ind.	Description	Fonction
13	Red LED	Fault
14	Orange LED	Working (other than production)
15	Green LED	Production

The machine is totally programmable via a man/machine interface. The screen indicates continuously, by a simple identification, the status of the machine and it enables the operator to have access to the essential functionalities : ON / OFF - FLUSHING / PRODUCTION.

The information relating to the operating of the machine (real time display of the ratio, of the consumption...) can be read on the LCD screen.

The PU 3000 continuously saves data on the consumptions of base, catalyst and solvent as well as the total consumptions and the emissions of Volatile Organic Compounds (VOC) during the operation of the machine (production mode only).

On the box of the machine, a seal gland enables an electrical supply to the machine with electricity via a safety isolating switch (115V / 230V).

The pictograms located under the screen allow the user to remember easily the various functions managed by the PU 3000.

Pictogram	Mode	
	Production	F1
	Flushing	F2
	Parameters	F3
	Consumptions / Print	F4
	Feeding of the pumps	F5

3. OPERATING DESCRIPTION

The 2 BASE and CATALYST materials are sent to the mixing machine from 2 pumps.

In production, as well as in regeneration, the machine injects a small volume of catalyst (P-6) in the base continuous flow.

The PLC continuously checks the mixing ratio and if it notices a fault that it cannot correct, an alarm is activated. The machine goes into safety mode.

The capacity of the pumps is configured (for the BASE pump : P4 parameter, for the CATA pump : P5 parameter) depending upon the equipment versions.

4. FEATURES

<p>Number of colors : 1 Number of catalyst : 1 Solvent and water-based paints compatibility Control via a magnet in the control box Continuous mixing check Adjustable threshold alarm Adjustable pot-life indicator Automatic flushing cycle (time) VOC display Consumptions' total indicator : base, cata, solvent, VOC Printing (connection to a printer or to a computer)</p>	<p>Voltage : 230V / 115V - 10W Air pressure: Mini 4 bar / 58 psi - Maxi 6 bar / 87 psi Dew point = + 3°C / 37°F Filtration 5µm Operating pressure : from 0-6 bar / 0-87 psi or from 6-40 bar / 87-580 psi for the pneumatic version from 30 to 180 bar / from 436 to 2610 psi for the Airmix® version from 60 to 350 bar / from 870 to 5076 psi for the Airless version from 30 to 180 bar / from 436 to 2610 psi for the 4 L 30/1 version from 60 to 350 bar / from 870 to 5076 psi for the 4 L 53/1 version Adjustable mixing ratio : from 0.6/1 to 20/1 (BASE volume / CATALYST volume) (from 160% to 5%) Mixing precision : ± 1 % Répeatability : ± 1 % Mixed fluid output : refer to § 12 & 13 Maximum operating temperature : 50°C / 122°F</p>
<p>Weight : 115 kg / 253.5 lb (Pneumatic version) 187 kg / 412 lb (Airmix® version) 217 kg / 478.5 lb (Airless version) 170 kg / 375 lb (4 L 30/1 version) 210 kg / 463 lb (4 L 53/1 version)</p> <p>Dimensions :</p> <ul style="list-style-type: none"> - Control box : 355 mm x 275 mm x 135 mm - Fluid frame : <ul style="list-style-type: none"> 860 mm x 670 mm x 1280 mm (pneumatic version) 860 mm x 670 mm x 1270 mm (Airmix® version) 960 mm x 670 mm x 1400 mm (Airless version) 960 mm x 670 mm x 1405 mm (4 L 30/1 version) 960 mm x 670 mm x 1435 mm (4 L 53/1 version) 	<p>Connections :</p> <ul style="list-style-type: none"> Air inlet : F 3/4 BSP (air inlet valve) Fluid outlet (mixer) : <ul style="list-style-type: none"> F 3/4 JIC or assembly of a fitting (→ M 1/2 JIC)

5. INSTALLATION

■ HANDLING

The PU 3000 system with relevant weight and dimensions must be handled by appropriate means.

Nota : The handling of the machine must be carried out by a qualified staff, in an appropriate space, correctly cleared to avoid any risks of fall or of crushing of people.



Nota : The ring located above the cover is for the hoisting of the pump and shall not be used for the handling of the complete machine.

The frame has 4 holes (\varnothing 9) to be fixed on a bracket or on the floor.

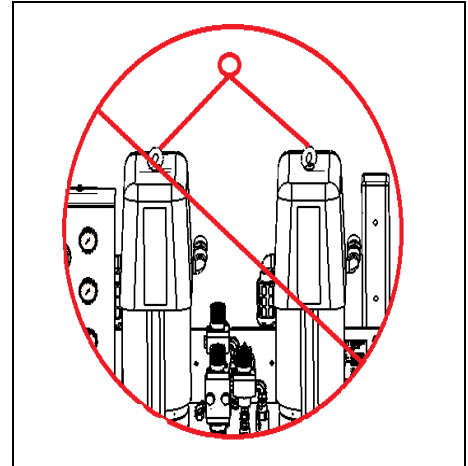

■ STORAGE

Storage before installation :

- Storage ambient temperature : 0 / + 50 °C. / 32 / +122° F
- Protect the equipment against dust, running water, dampness and shocks.

Storage after installation :

- Operating temperature : + 15 / + 35 °C. / + 52 / + 95° F
- Protect the equipment against dust, running water, dampness and shocks.

■ ENVIRONMENT ON THE AREA

The unit must be installed on a horizontal stable floor (eg : flagstone).

Ensure the machine is stable.



The working area must be correctly ventilated.

■ **DESCRIPTION OF THE LABEL MARKINGS**

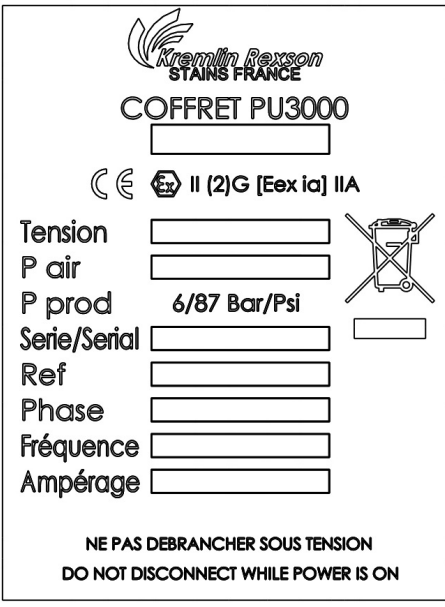
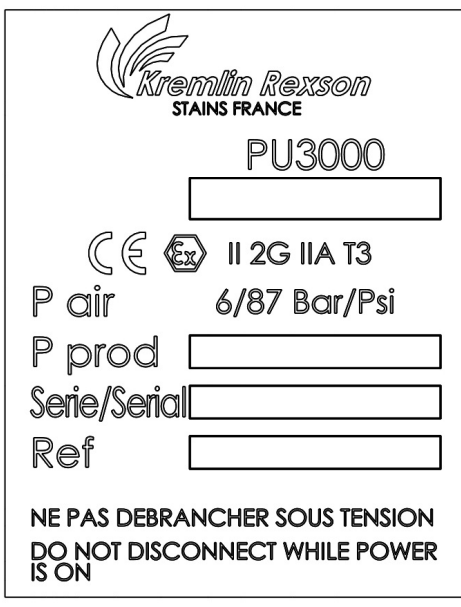
The PU 3000 machine is fitted with 2 label markings : a plate on the control box and another one on the fluid equipment.

 <p>Marking label on the control box (box located outside the spray booth)</p>	 <p>Marking label on the fluid module (fluid module assembly can be located inside the spray booth → marking in accordance with the ATEX directive)</p>
---	--

Marking according to the ATEX Directive

KREMLIN REXSON STAINS FRANCE	Name and address of the manufacturer
CONTROL BOX : CE  II (2) G [EEx ia] II A	II : group II (2) : Control box contains components ensuring the safety of the class 2 fluid module. G : gas [EEx ia] : Control box contains SI ia barriers. IIA : Gas group for the equipment category
FLUID MODULE : CE  II 2 G IIA T3	II : group II 2 : class 2 Surface equipment meant to area where explosive atmospheres due to gas, vapours, mists are liable to appear from time to time in usual operating G : gas IIA : Gas group for the equipment category T3 : Maximum surface temperature : 200°C / 392°F
P air	Maximum air pressure
P prod 6/87 Bar/Psi	Maximum fluid pressure
Série / Serial	Number given by KREMLIN REXSON. The two first numbers indicate the manufacturing year.
Ref	Part number of the PU 3000 machine
Phase	Single phase
Fréquence	50-60Hz / Mains frequency
Ampérage	Maximum current used

■ INSTALLATION DIAGRAM

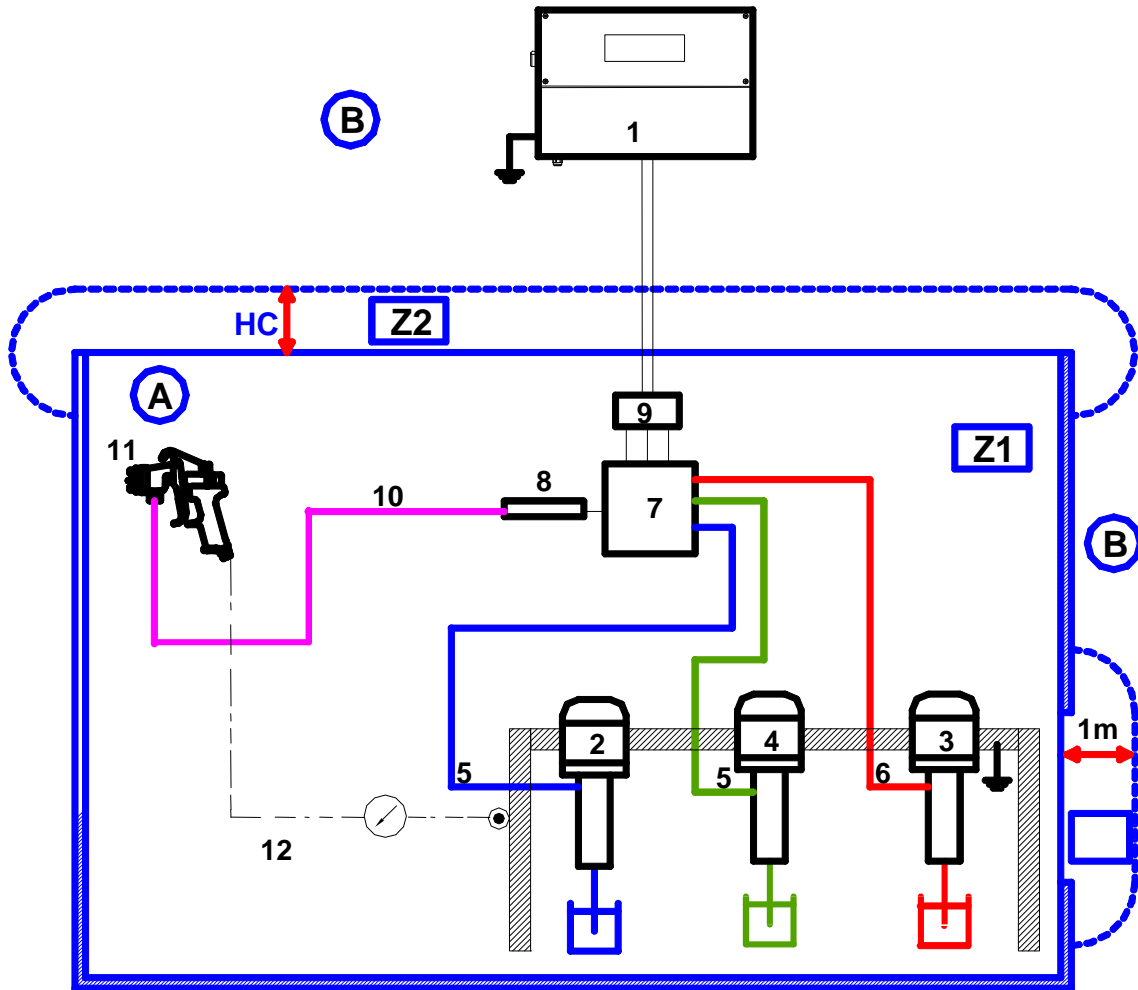

A	Potentially explosive area : area 1 (Z1) or area 2 (Z2) (spray booth)	6	PTFE HP fluid hose
B	Non explosive area (safe area)	7	Automatic valves
1	PU 3000 control box	8	Mixer
2	BASE pump	9	Electrovalves
3	CATALYST pump	10	HP Fluid hose (not supplied)
4	Flushing pump (option)	11	Gun (not supplied)
5	HP fluid hose	12	Gun spraying air from the machine



The 1 m / 39.37" distance indicated in these diagrams is given for information only and holds harmless KREMLIN REXSON. The user is liable for the exact delimitation of the areas which depends on the material used, the material environment and on the use conditions (refer to EN 60079-10 standard). The 1 m / 39.37" distance could be modified if analysis carried out by the user deems it necessary.



- ➔ The control box must be connected to a supply fitted with a ground. The bracket of the pumps is fitted with a ground cable. That must be grounded.
- ➔ Do not install the paint drums underneath the pumps or the electric equipment. Place them in front of the frame. Install a cover on the drums to reduce the diffusion of gas and vapours in the booth.
- ➔ The electrical cable connecting the chassis mounted electric components to the control box must be installed so that at no time is any risk from mechanical damage, chemical corrosion or excessive heat. Please ensure that the wiring loom is kept separate from any other electrical cables that are not intrinsically safe.

■ INSTALLATION

There are different ways to install the PU 3000 to answer to the majority of the installations.



The control box of the PU 3000 mixing machine must be installed outside the spray booth in a safe area.

Assembly for piloting outside the booth :

The machine is in two parts to enable the control box to be fitted outside the booth (cable of 8 m / 26.2 ft between the 2 elements).

Nota : Drawing of a unit, model PU 3000 Airmix®

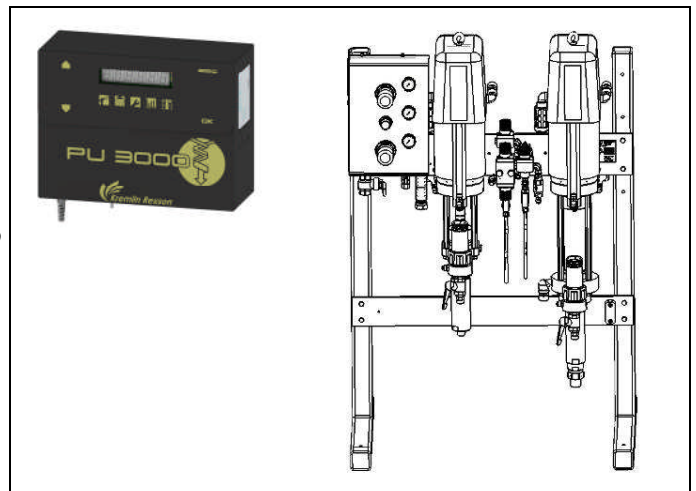

Assembly for machine control in the booth :

There is a booth mounting control kit (available in option).

That kit enables the user to fix the control box on the booth by means of a glass panel and to control the machine inside the spraybooth.

The control is carried out thanks to a magnet provided with the machine. The distance between the control box and the fluid frame is of 8 m / 26.2 ft (cable supplied with the machine).

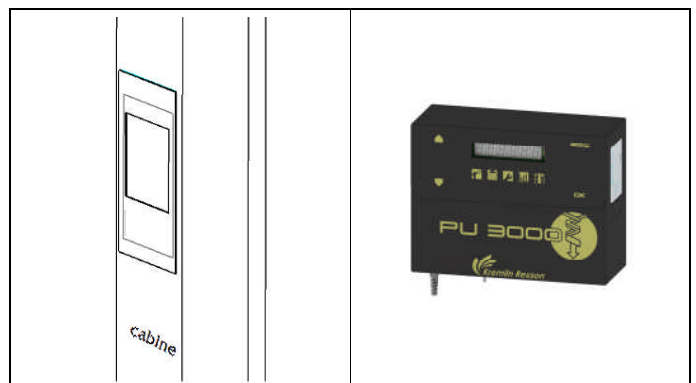

■ CONNECTION OF THE CONTROL BOX AND OF THE FLUID FRAME

➡ The PU 3000 must be connected to a dry and clean compressed air network (minimum 4 bar / 58 psi) and to a single phase electric supply (115V / 230V) connected to an isolating switch. The electric supply must have an appropriate protection (30 mA). The network ground will be connected in the control box on a connect provided and identified with the

symbol .

 **Before connecting the PU 3000, be certain the mains voltage is the same as the one of the machine (230 V).**

If no, open the electric box removing the protective housing and move the jumper (230V → 115V).

The machines with a stabilized electric supply tolerate all voltage types (115V / 230V).

Connect the air equipment of the PU 3000 to the pneumatic network with a conductive hose (minimum 16 mm / 5/8 dia).

Nota : these hoses are not supplied in the standard version.

The air connection of the machine is Female 3/4 BSP (air inlet valve).

The connection between the control box and the electrovalves located on the frame, is carried out via cable, length : 8 m / 26.2".

Between the mixer outlet and the spray gun, you must install a fluid hose, model HP (high pressure) ( act according to the pressures the pumps supply).

**Fuse 160 mA
for machine with serial number < to 09Y1080**

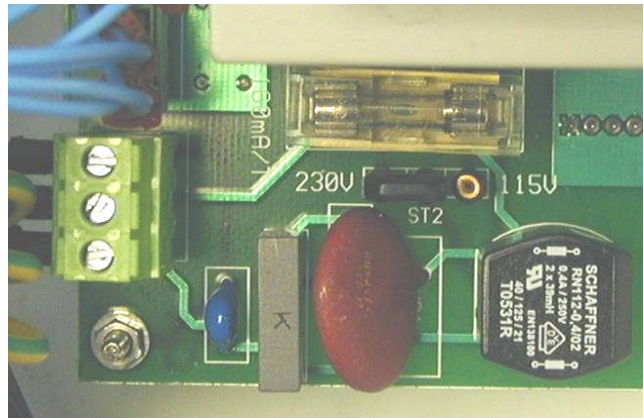

**Fuse 315 mA
for machine with serial number >to 09Y1080**

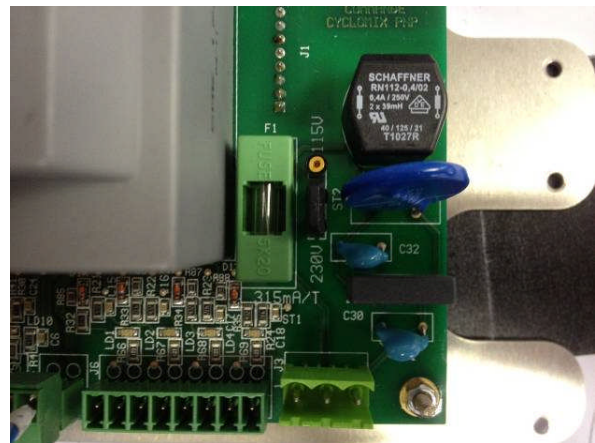

Machine with a stabilized electric supply

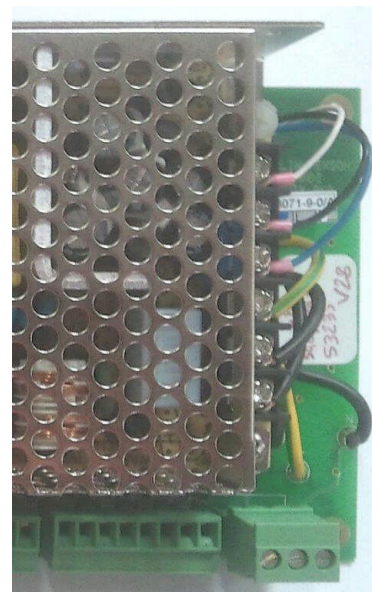

6. OPERATING

■ DRIVING FROM THE MACHINE

SCREEN

Different menus and information relating to the machine are displayed on the alphanumeric screen.

KEYBOARD

ESC	That key enables the user to quit the menus or the different modes (production, flushing, parameters).
OK	That key enables the user to enter in the different menus or to validate a value of parameter.
▲	That key enables the user to shift from a menu to another and to increase the value of a parameter during modifications of value.
▼	That key enables the user to shift from a menu to another and to decrease the value of a parameter during modifications of value.

The keyboard is controlled thanks to a magnet provided with the machine. That control mode enables the user to drive the machine inside the booth if the box is installed behind the booth glass panel. This technology enables the operator to save time and to carry out his work from the place application.

■ SWITCHING ON THE MACHINE



The placing of the system into operation requires that the BASE, CATALYST and SOLVENT drums are full enough to ensure the production.

Connect the gun before placing the system into operation.

Unscrew the 3 air regulators before supplying air to the installation.

Supply air to the PU 3000 (minimum 4 bar / 58 psi).

Switch on the control box (switch located on the side of the box).

When switching on the control box, a menu is displayed on the screen.

Nota : Parameters have been set up in the factory before the delivery of the machine. You must adapt the parameters to the use. They must be modified by an authorized person (refer to list of parameters).

7. FIRST SWITCHING ON

STANDARD MENU

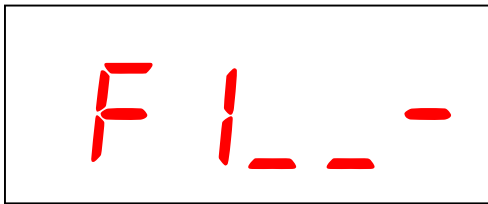

Countdown on fluid life time.
(countdown from 9 to 0; 9 represents 90% of the remaining time before the regeneration).

A line is visible when the PU 3000 is flushed.

When switching on, the machine is waiting. The 'F1' menu corresponds to the shift to the production mode. There are five different menus : they enable to control the PU 3000.

- F1 : production
- F2 : flushing
- F3 : parameters
- F4 : consumptions
- F5 : feeding of the pumps

To surf from a menu to another, you must move placing the magnet on the sensors indicated with '▲/▼'.
The menus scroll as follows :

Arborescence of the menus :

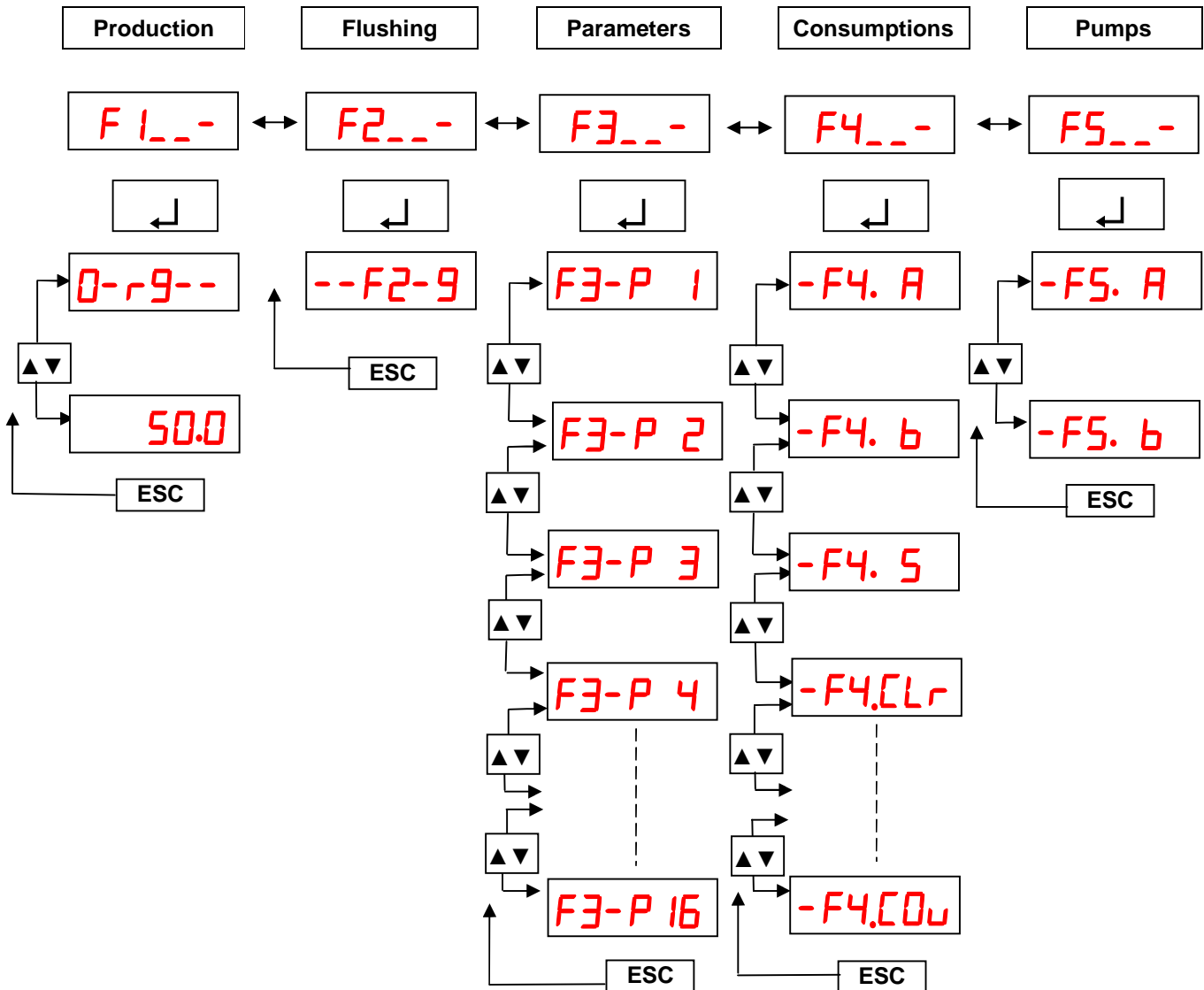

8. FIRST PLACING INTO OPERATION

■ BEFORE SWITCHING ON

Before switching on, half fill the cups with T lubricant or with the appropriate solvent (only for standard fluid sections, not for Flowmax® fluid sections).

Nota : the cup nut must be slightly tightened with the wrench provided. Too much tightening may damage the cup seals.

Tightening of the wetting cup :

- Fill the cup with T lubricant,
- Start the pump, then tighten the cup after 10 minutes, then 1 hour, then 1 day of operating,
- If you notice any leakage, the cup must be tightened.

Nota : Stop the machine and depressurize the air and fluid networks to tighten the cup.

■ FLUSHING OF THE PUMPS AND OF THE MACHINE IN SOLVENT



During that first placing into operation, it is compulsory to have all the pumps into solvent as well as the machine to ensure the good quality of the fluid get by the PU 3000.

The fluid pressure must not exceed 1 bar / 14.5 psi on the gauges.

- Carry out the connections indicated at § 5 (INSTALLATION),
- Immerse the suction rod of the BASE pump in the solvent container,
- Close the gun air supply valve,
- On the page of the display main menu, enter 'NORMAL OPERATING' (F5 then **OK**), then select the A pump (▲ or ▼, and **OK**),
- Trigger the gun to start the A pump with solvent and increase the fluid pressure to at least 1 bar / 14.5 psi (reading on the gauge) or go through the drain valves,
- Release the gun trigger when there are no more air bubbles in the solvent at the gun nozzle,
- Immerse the suction rod of the CATALYST pump in a solvent container,
- On the page of the display main menu, enter 'NORMAL OPERATING' (F5 then **OK**), then select the B pump (▲ or ▼, and **OK**),
- Trigger the gun to start the B pump with solvent and increase the fluid pressure to at least 1 bar / 14.5 psi (reading on the gauge) or go through the drain valve,
- Release the gun trigger when there are no more air bubbles in the solvent at the gun nozzle,
- Turn the air valve that supplies air to the flushing pump,
- On the page of the display main menu, enter 'FLUSHING MODE' (F2 then **OK**),
- Trigger the gun to prime the SA pump with solvent and increase the fluid pressure to at least 1 bar / 14.5 psi (reading on the gauge),
- Release the gun trigger when there are no more air bubbles in the solvent at the gun nozzle,
- Do not modify the factory parameters for the moment.



**Caution : Do not supply gun with atomising air to prevent any atomisation and point the solvent fan into a container.
We advise you to wear protective glasses and gloves.**

- Go out from the 'NORMAL OPERATING' mode passing to ESC.
- Close the air supply valve of the flushing pump.

■ START UP OF THE MACHINE

- Take off the BASE and CATALYST suction rods from the solvent containers and introduce them in their respective container.

⚠ Caution : never invert the suction rods.

- Open the drain valves located at the outlet of the fluid sections. Start up the pumps. Prime the pumps, then close the drain valves.
- Pass to production mode and let the fluid flow until it flows clean. In case of alarm, disable then go to production mode.

CAUTION : do not supply atomising air to the gun.

- Carry out a flushing to clean the mixed circuit. As soon as the solvent is clean, pass to ESC.

The parameters are preset up in the factory. You can change them (refer to § 9).

■ MIXING RATIO CHECKING

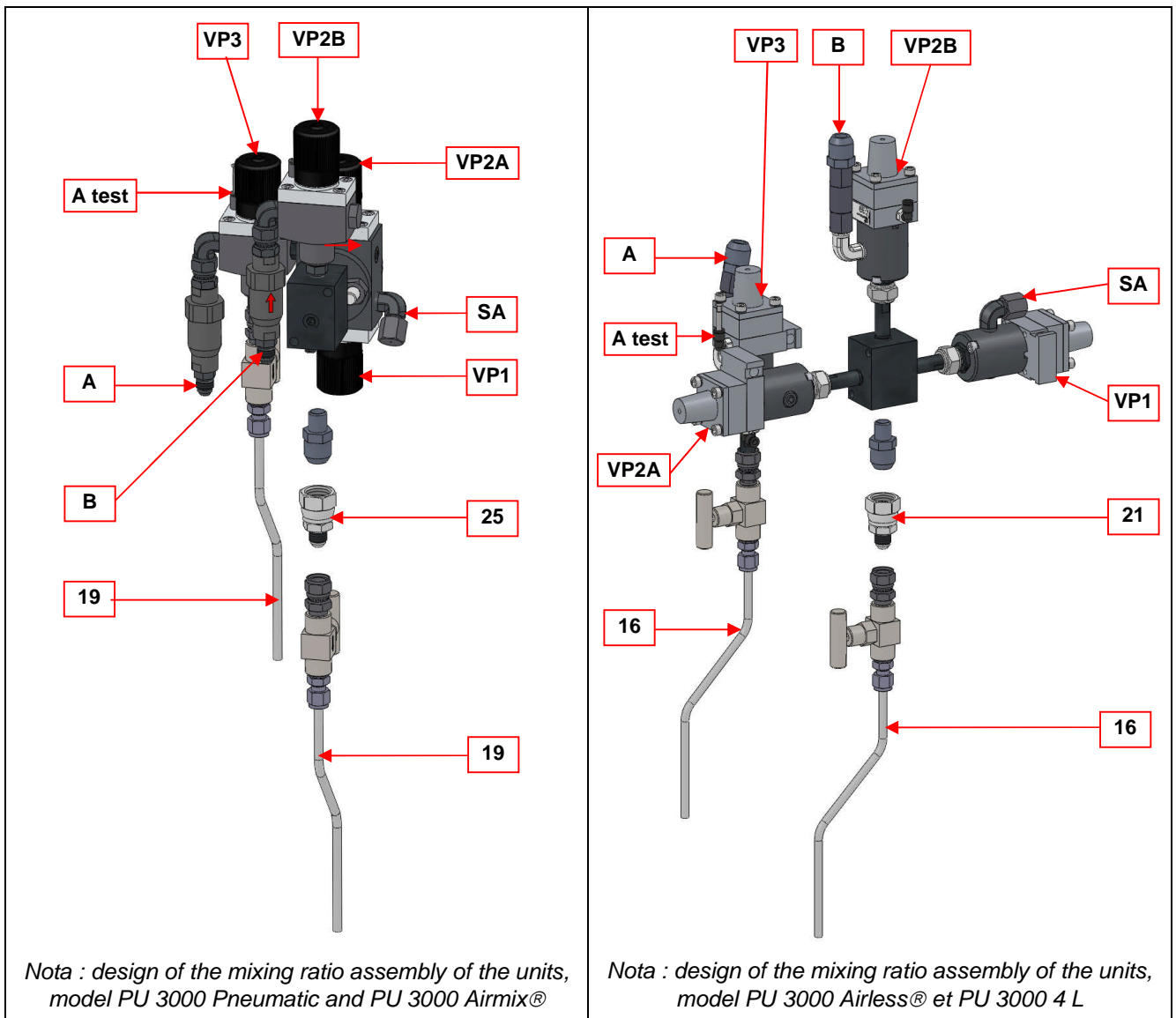

Switch off the unit.

Remove the 'mixed fluid' hose located on the outlet of the mixing unit. Install, instead of it, the fitting (21 or 25) and the needle-valve assembly (16 or 19) supplied with the machine.

Take off the control air hose on the VP2A BASE valve.

Connect that hose to the VP3 valve. The VP3 valve is originally supplied with a needle valve assembly (16 or 19).

Switch on the unit.

Pass in **F 5** mode to adjust the opening of the needle-valves.

-F5 A Prime the A pump and adjust the opening of the needle-valve.

-F5 b Prime the B pump and adjust the opening of the needle-valve.

Place the beakers underneath the valves.

Input **-F3 P 16**

The PU 3000 passes in test mode and displays **t 50.0**

 **Caution : the fluid pressure must be lower than 200 bar / 2900.6 psi.**

The BASE and CATA materials are dispensed into the beakers. After a while, close the needles' valves and check the ratio.



Activate ESC to stop the test and only after that you can removing the test outlet.

Nota : During that stage, you can not use the spray gun.

 **When the mixing ratio checking is over, switch off the PU 3000 machine.**

Disconnect the air hose from the VP3 valve and connect it to the VP2A BASE valve.

Remove the needle-valve assembly (16 or 19) and the fitting (21 or 25). Screw again the fluid hose on the fitting (M 3/4 JIC) at the outlet of the mixer unit. Start up the machine : enter 'PRODUCTION MODE' (F1 then **OK**).

-  **Wear protective glasses to protect the eyes from possible discharges during the handling of the valves.**
-  **Flush the needle valve assembly that has been removed and do not leave the catalyst crystallize : - Flush the CATA test outlet : input F2 to carry out the flushing. When it is clean, activate ESC.**
 - Flush the BASE test outlet : invert the test outlets and carry out a flushing until it is clean.

9. APPLICATION PROGRAMMING (F3)

To alter the parameters of the PU 3000, go to F3, then validate. To shift from a parameter to another, use the arrows ▲ or ▼.

Select the parameter to alter. Depress the key **OK**, then the arrows ▲ or ▼ to increase or decrease the value. Activate **OK** to validate the new value or ESC to cancel.

To quit a parameter, activate **ESC**.

To quit the PARAMETERS menu, activate **ESC**.

The parameters are pre-set up in the factory. They must be adjusted (by an authorized person) to suit the material to be processed.





The calibration of the stroke length is carried out in the factory. When removing the movement sensors or when disassembling the fluid section from the motor, it is important to initialize the pumps (refer to Validation of the initialization mode, page 23).

■ PASSWORD

When you start the machine for the first time the access code of the menu 'Parameters' is deactivated, everyone is able to modify the machine's parameters.

To activate this access code you have to :

- enter in the parameter 0 of the menu F3: **F3--** → «key » → **P -- 0** → «key ».
The code '0000' appears, it's the code present by default in the machine.

- change the code by using the arrows ▲ or ▼ and the «key » for each digit which compose this code.

Once the access code was validated, the access is protected by the password. Only the people who know this password and those which know the administrator code '5555' will be able to reach the menu 'Parameters'.

Each time a user wants to enter in the menu 'Parameters' the password will be required: **[0---**.

The user shall enter the password by using the arrows ▲ or ▼ and the «key » for each digit which compose this code :

- If the entered code is correct, the following fonts **-----** appear.

- If the entered code is incorrect, the word '**Error**' appears and the machine allows you to enter the password again (Press 'Esc' to return to the principal menu).

If you want to deactivate the password, you just have to parameterise the code '0000' again as access code.

■ PROCEDURE TO GET THE VERSION NUMBER OF THE ELECTRONIC CARD

- Switch off the unit.
- Input **OK**.
- Switch on the control box : The version number is displayed.
- Release **OK** to start the machine out.

■ PARAMETERS

Parameters	Description	Factory adjustment	Your adjustments
F3- -P0	Parameter of the password	0000	
F3- -P1	Mixing ratio parameter. Percentage of catalyst in the base, from 0,1% to 160%	50 %	
F3- -P2	Parameters of the mixed fluid life time Minimum value : 1min Maximum value : 999 min	30 min	
F3- -P3	Regeneration volume parameter in cubic centimetre Minimum value : 1 c.c Maximum value : 9 999 cc	200 cc	
F3- -P4	Section of the A piston Minimum value: 1 mm ² Maximum value : 99 999 mm ²	For fluid section - 50 : 465 (airmix® version), 485 (pneumatic version) For fluid section - 50cc : 555 (airless version) For fluid section - 225cc : 1010 (4 L 30/1 version) For fluid section - 227cc 1025 (4 L 53/1 version)	
F3- -P5	Section of the B piston Minimum value: 1 mm ² Maximum value : 99 999 mm ²	For fluid section - 50 F : 470 (airmix® version), 490 (pneumatic version) For fluid section - 50cc : 555 (airless version) For fluid section - 225cc 1010 (4 L 30/1 version) For fluid section - 227cc 1025 (4 L 53/1 version)	
F3- -P6	Injection volume Minimum value : 0,1 cc Maximum value : 999,9 cc	4,8 cc	
F3- -P7	Mixing tolerance Minimum value : 0,1 % Maximum value : 100 %	3 %	
F3- -P8	Alarm volume for the A pump Minimum value : 1 L Maximum value : 40 000 L 0 : parameter not taken into account OK : reset of low level pump shut off –A-	0	
F3- -P9	Alarm volume for the B pump Minimum value : 1 L Maximum value : 40 000 L 0 : parameter not taken into account OK : reset of low level pump shut off –B-	0	
F3- -P10	Initialization mode (values of the high and low thresholds of the movement sensors) OK : to activate that mode		

Parameters	Description	Factory adjustment	Your adjustments
F3- -P 11	Flushing time Minimum value : 10 seconds Maximum value : 500 seconds	120 s	
F3- -P 12	Flushing volume Minimum value : 10 cc Maximum value : 5000 cc	500 cc	
F3- -P 13	Number of thousands of cycles before preventive maintenance on the A pump Minimum value : 1 Maximum value : 9999	500 cyc (i.e. 500 000 cycles)	
F3- -P 14	Number of thousands of cycles before preventive maintenance on the B pump Minimum value : 1 Maximum value : 9999	500 cyc (i.e. 500 000 cycles)	
F3- -P 15	Percentage of dry extract in the base Minimum value : 0 % Maximum value : 100 %	50 %	
F3- -P 16	Ratio Test mode OK : to activate that mode		

■ VALIDATION OF THE INITIALIZATION MODE

That mode enables the machine to define the high and low settings of the movement sensor on each pump.

After validating the **F3- -P 10** parameter, the machine displays **A1**, and controls the down stroke on the BASE pump piston : open the gun or the BASE drain valve to make the piston go down.

Once the BASE pump piston is in low position, close immediately the valve or the gun avoid the decompression of the circuit, then input **OK**.

Then, the piston displays **A2**, it goes up and is waiting for the high setting of the BASE pump. Open the gun or the BASE drain valve to make the piston go up.

Input **OK**.

The machine displays **b1**, and controls the down stroke of the CATA pump piston : open the gun or the CATA drain valve to make the piston go down.

Once the CATA pump piston is in low point, close immediately the valve or the gun avoid the decompression of the circuit, then input **OK**.

Then, the piston displays **b2**, it goes up and is waiting for the high setting of the CATA pump : open the gun or the CATA drain valve to make the piston go up. When the piston is up, close immediately the circuit to avoid the decompression.

Input **OK**.

After that last validation, the machine comes back to the parameter **F3- -P 10** menu.



Caution : that parameter must be modified only when changing the sensor (disassembly or re-cabling) or when updating the software or or of the electronic card or when changing a barrier Zener (CA and CB only). If the procedure is launched, it must be carried out in entirety, if not : the machine will not work correctly any more.

■ PRODUCTION (F1)



The CATALYST pressure must always be higher by 5 to 10% than the BASE pressure.



Real mixing ratio

If the machine is in mixed material, open the gun spraying air supply valve.
Trigger the gun.
Adjust the spraying air regulator to get the desired fan.



If the machine is not in mixed material, a regeneration is automatically carried out to bring the mixed material to the gun.

We advise you to shut off air during that stage.

When passing to production for the first time, the machine carries out a regeneration.



The display consists of a countdown that enables to know, in percentage (9 → between 90% and 100% of the volume), the volume remaining to be dispensed according to the P3 parameter. At the end of that stage, the machine enters in production. You can also activate **ESC** during the fluid priming; we advise you not to start painting immediately.

In production, there are 3 main screen messages:

- The operator is spraying and the PU 3000 is operating correctly. The real mixing ratio is displayed on the screen.

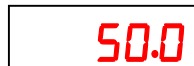

- The machine stops because of a malfunction. The kind of breakdown is displayed on the screen, the machine emits an alarm signal to inform the operator (cf § 'TROUBLESHOOTINGS').

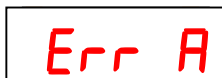

- The machine has reached the maximum life duration of the material and passes automatically in regeneration mode. The machine emits an alarm signal to inform the operator. The following screen is displayed :

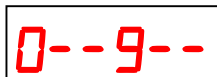

Open the gun until the regeneration ends (shut off spraying air), then the machine passes to production.



You can stop the regeneration by activating **ESC**. Then, the regeneration will stop, but be careful, the quality of the mixed material can be inferior.

To exit from production : activate **ESC**.

Nota : We recomend to keep the nozzle on the gun during the color priming / regeneration.

■ **FLUSHING (F2)**

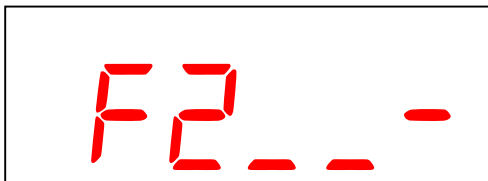

This menu is used for flushing. When you want to flush the machine, activate **OK** when you are on the F2 menu.

After confirming via **OK**, the machine opens the solvent valve. The buzzer sounds intermittently. Check the solvent pump supply valve is open.

A countdown begins : **F2-9**, then **F2-8**.

The machine stops when the countdown is over.

The machine closes the solvent valve and the mixed material flushing has ended.

Nota : Close the spraying air valve during the 'FLUSHING' stage.

During the first flushing, you can determine the solvent volume (F3 P12 parameter) consumed during the flushing time (F3 P11 parameter). Once determined, enter your parameters accordingly.

■ **CONSUMPTIONS / PRINT (F4)**

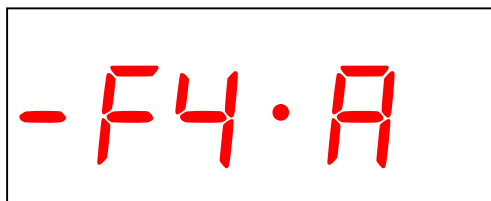

The 'F-4' menu enables to view the consumptions of each material (color, catalyst in L). You can also print the ratio of the consumptions as well as the parameters of the applications : you must connect a connection cable to a printer or to a computer (RS 232 connection) (printer not provided) (refer to Downloading data from PU3000 to a computer page 27).

-F4.A	Consumption of the base	-F4.CO_u	Consumption of the VOC
-F4.b	Consumption of the catalyst	-F4.CL_r	Enables the user to reset the consumptions activating the key OK thanks to a sub menu
-F4.5	Consumption of solvent	-F4.P_rn	Enables the user to print the consumptions and the parameters activating the key OK

Arborescence of the F4.Clr menu :

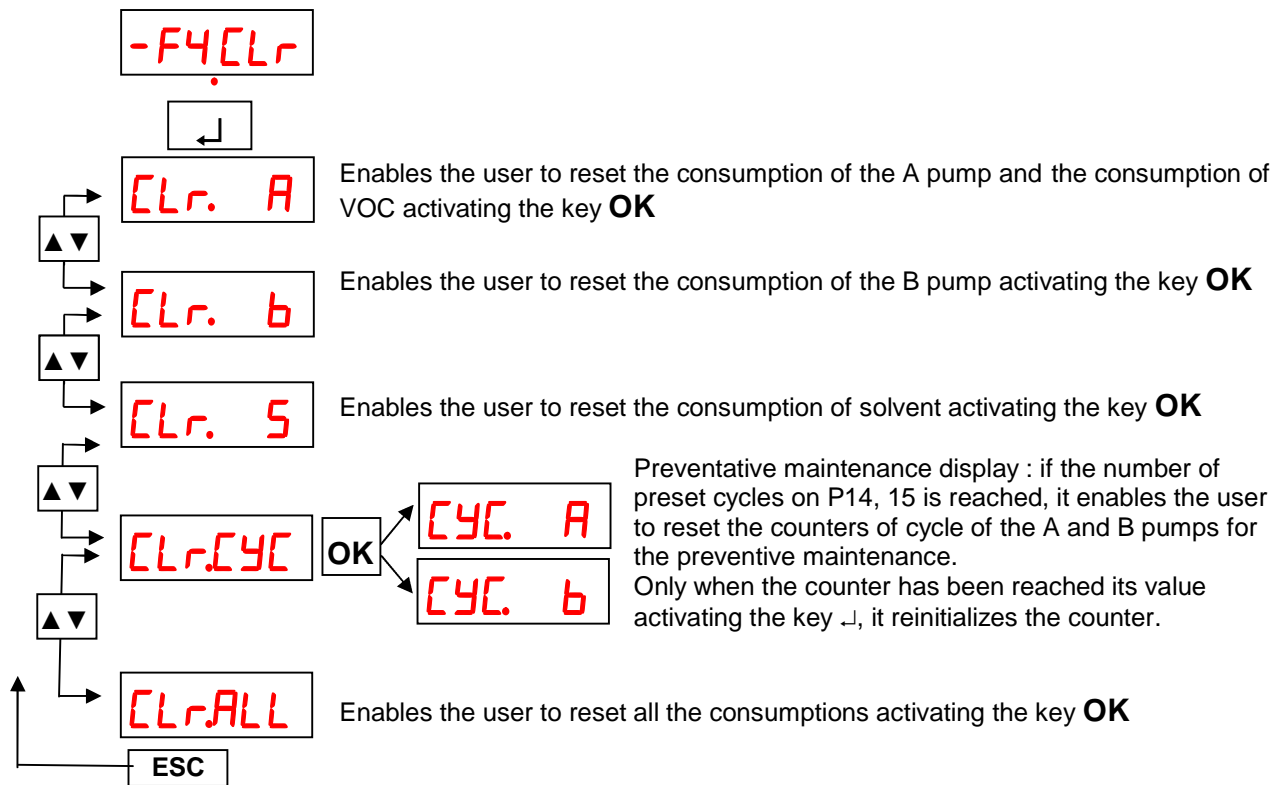

■ DOWNLOADING DATA FROM PU 3000 TO A COMPUTER

Preamble / "Hyper Terminal" issue

This application is necessary. Two cases are to be considered :

- .PC under Windows XP/Vista/2000,
- .PC under Windows 7.

- **With Windows XP/Vista/2000**, "HyperTerminal" application is available with the following path :
Menu Start > All programs > Accessories > Communications > HyperTerminal
- **With Windows7**, you will need to download freeware "HyperTerminal" from some website.

For example : <http://www.01net.com/telecharger/windows/Bureautique/telephonie/fiches/5829.html>

Once it is downloaded and installed, carry out a simple test of opening and closing.

It should look like this whenever open :

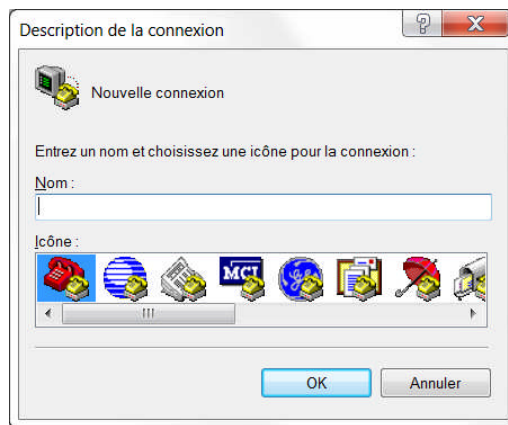

Switching of the control box

- Switch the control box.
- Link a "RS232 male / USB male" cable to the plug located below the Micro back frame, the other end to the USB plugs on the computer. Cable not supplied by KR.

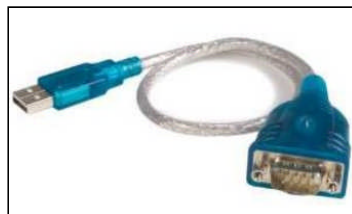

- According to the USB plug used a "port com" number appears in the "device manager" screen (Menu Start > Control panel > Device manager).

- After deployment of the "Ports" line, one of them indicates the cable pilot name ("Prolific USB" for example or else), followed by the "port com" number (COM5 in that display).

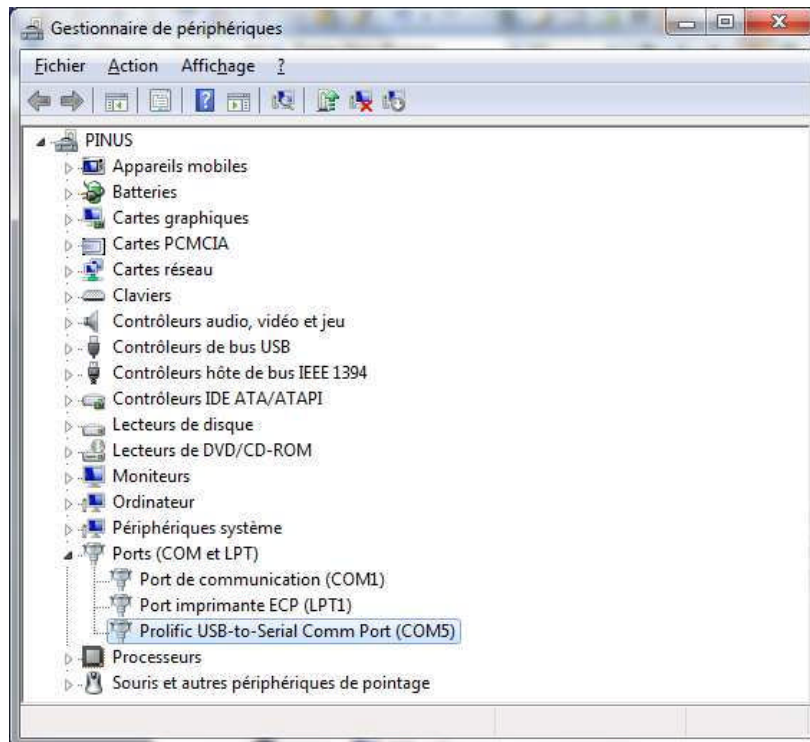

- Open "HyperTerminal" window.
- At the first connection, create a new connecting session, write a name in (order number or paint reference) by choosing the first left icon. Press OK.

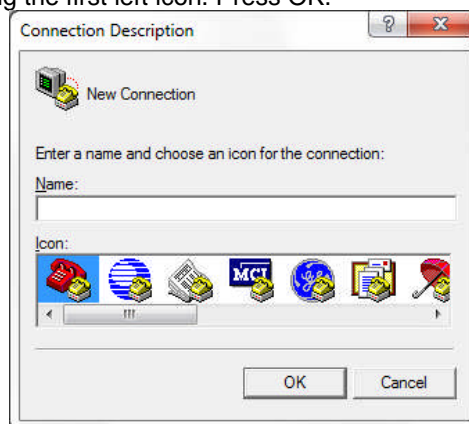

- This screen appears. Select the "port com" number previously noted during your connection. Press OK.

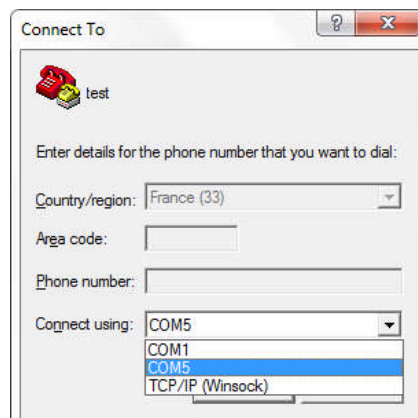

- That new screen will appears. Select band rate 9600 bits/s. Press OK.

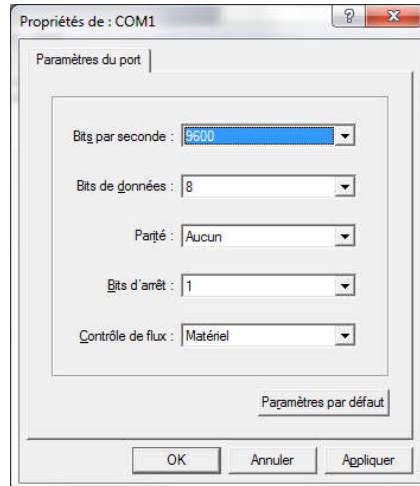

- A connection stopwatch gets activated. Leave the "Hyper Terminal" window open.
- If a session has already been created, opening the existing file is possible by going directly through the,  of the "HyperTerminal" menu, and by choosing it within the list of the *.ht files. (ex : PU3000usb).
- Create a .txt file through "transfer" (transfer > capture text), choose some file name as target (ex : dataPU3000.txt), with a location within the PC disk, and press "START" (the empty file is created / leave the HyperTerminal window always open) :

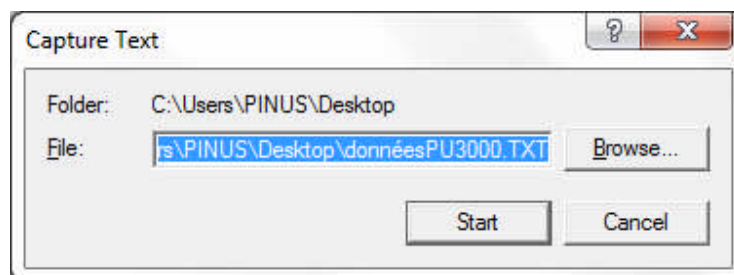
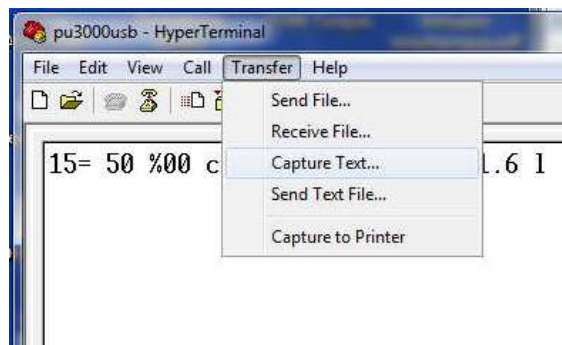

- Launch the data transfer from the control box (menu "F4. Prn" + OK), the data do appear (partially) in the display zone.

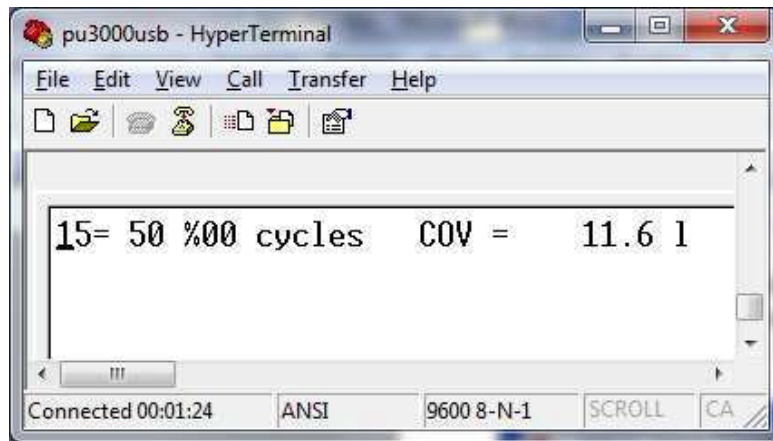

- Get back in the "transfer" menu (transfer > capture text) and press "Stop" :

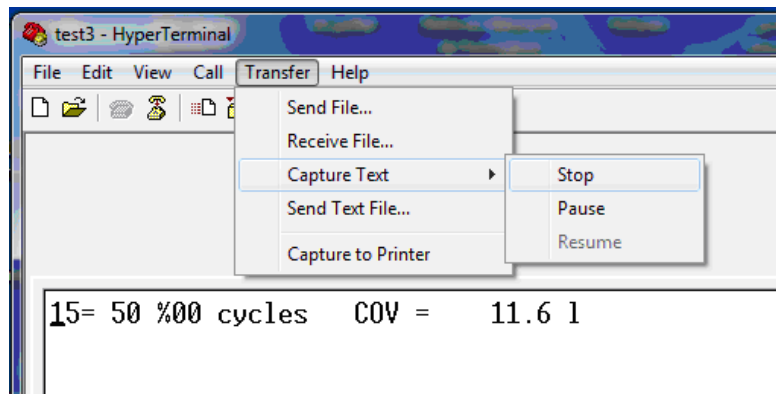

- Data then become available when opening the previous created .txt file.

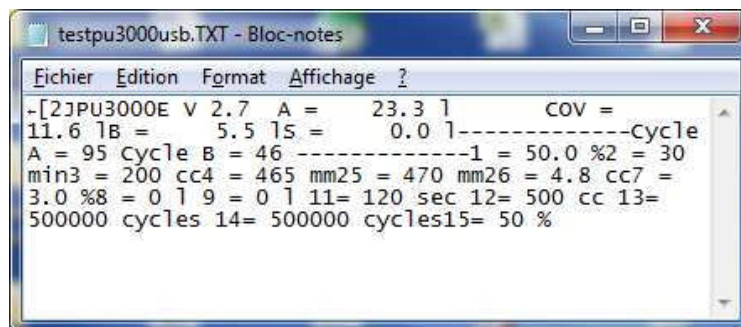

- From these displayed elements .txt (difficult to read up), make a simple "copy/paste" in an Excel file and data will appear as per that screen :

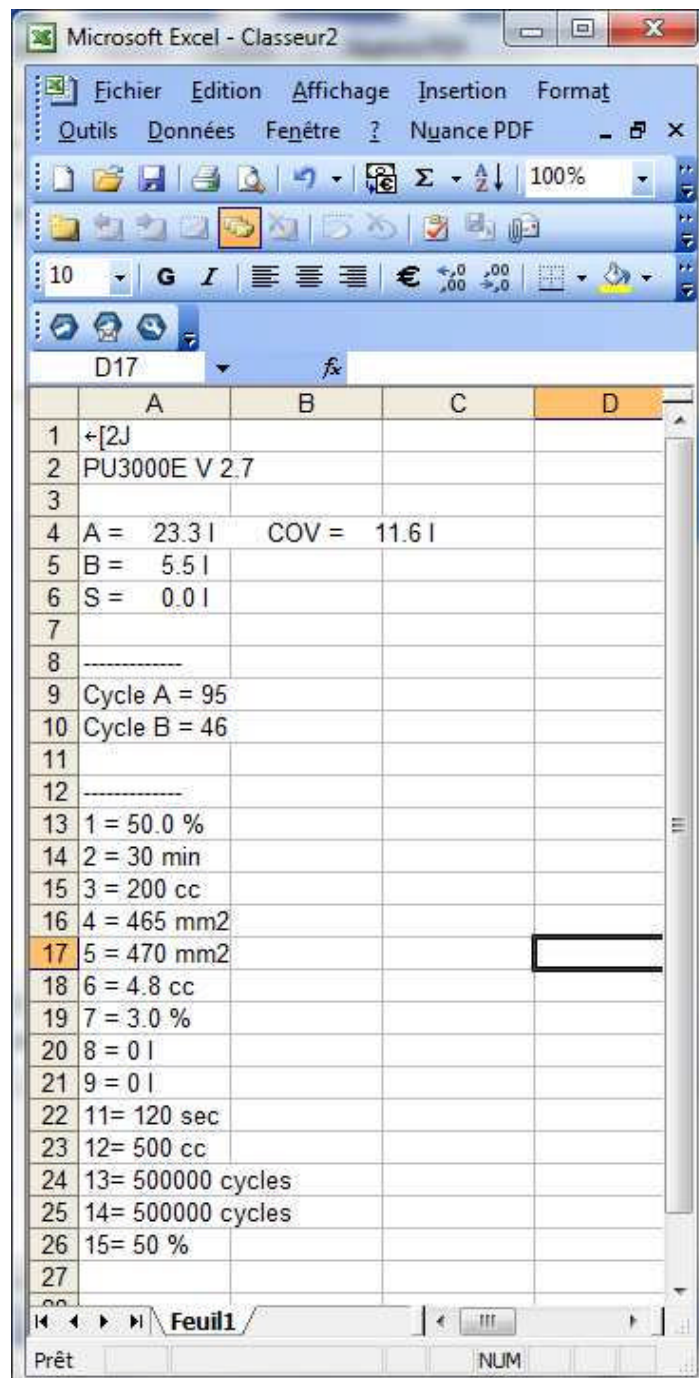

■ DRUM REPLACEMENT PROCEDURE

When replacing the drum, you should prime the pump to avoid air bubbles.

Nota : We recomend you to use a 6 L gravity cup (ref. 151140230) to feed the catalyst pump on a gravity mode to avoid air bubbles in the Flowmax pump.

10. INDICATIONS OF OPERATION GIVEN BY THE MACHINE

■ INDICATIONS GIVEN BY THE LEDS

Description	Function	Action
Red LED	Fault	The machine stops
Orange LED	Working	Function other than production (flushing, pot-life alarm ...)
Green LED	Production	
Green + orange LED	Waiting	
LED switched off	Programming	

■ MESSAGES GIVEN BY THE DISPLAY UNIT

The messages given by the display unit are for your information only but do not stop the machine.

Number of cycles' overrun indication

Messages	Indications
Cyc.A	Overrun of the number of cycles configured at the P13 parameter
Cyc.b	Overrun of the number of cycles configured at the P14 parameter
Cyc.Ab	Overrun of the number of cycles configured at the P13 & P14 parameters

Fluids' consumption alarm

Messages	Indications
--A--	A fluid consumption alarm → A container empty (volume fixed by the P8 parameter) OK (during at least 3 seconds) : reset of low level pump shut off –A-
--b--	B fluid consumption alarm → B container empty (volume fixed by the P9 parameter) OK (during at least 3 seconds) : reset of low level pump shut off –B-

11. MAINTENANCE



Never leave mixed material in the machine. Properly adjust the potlife parameter to avoid curing. Carry out a flushing when the work is over.
Flush when ending the work.

■ SYNOPTIC

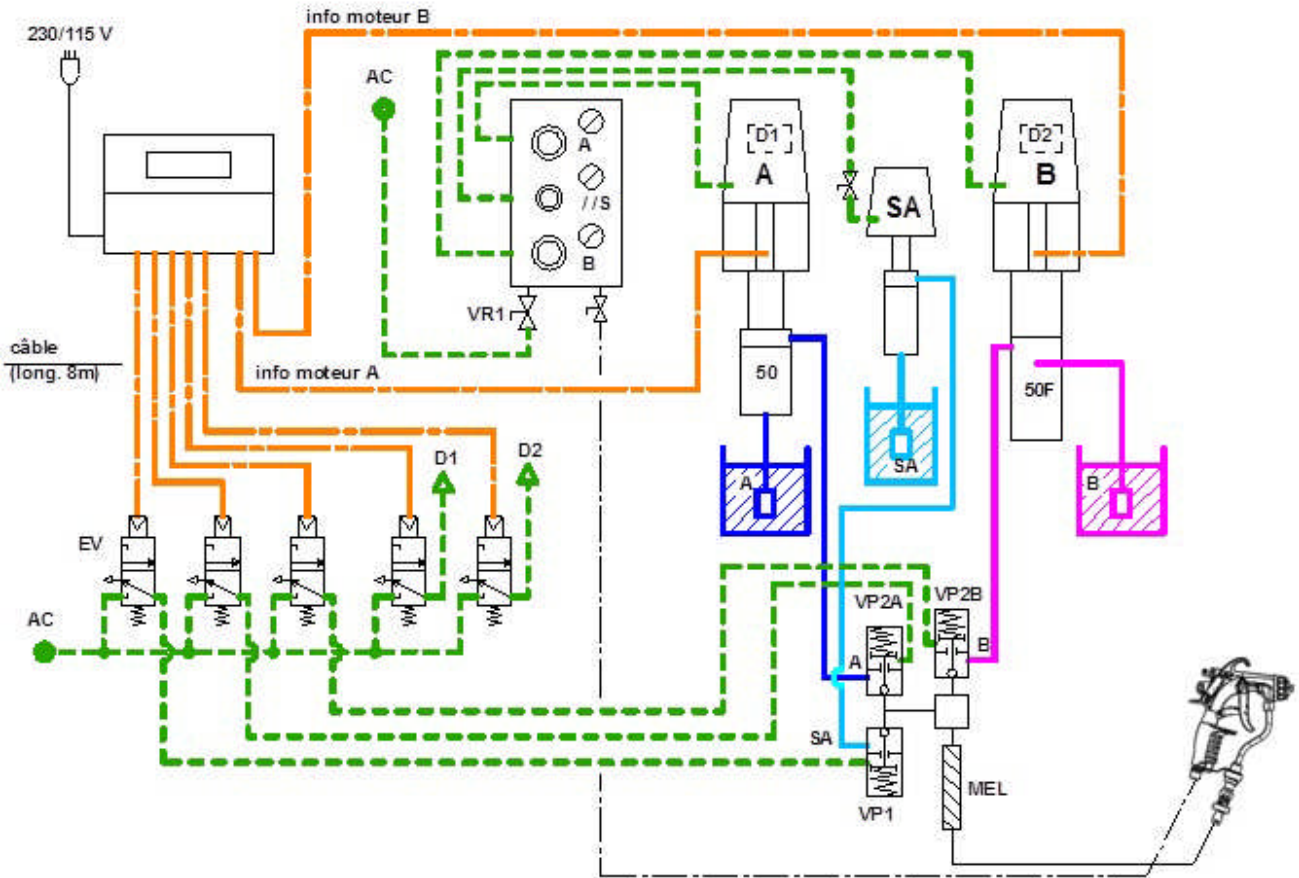

Nota : diagram of a unit, model PU 3000 Airmix®

■ MAINTENANCE PLAN

The life duration of the different elements depends on the properties of the material used. The following maintenance plan is for information only and can not be taken into account when making a complaint.

SUBSET	ELEMENT	OPERATION TO CARRY OUT	TIME EXPECTED	PERIODICITY	MACHINE STATE	TOOLS
Mixer	Mixer	Remove and install a new mixer	2 mn	1 year	stop	
BASE pump	BASE fluid section	Check the lubricant into the cup : its level (1/2 cup) and its colour (colourless)	2 mn	week	stop	T lubricant
		If the lubricant is contaminated, tighten the wetting cup on the upper packing (or change the seals of the packing, if necessary) ; do that with a depressurized pump	10 mn	month	stop	Wrench supplied
		Remove and clean the parts; change the seals and reinstall.	3 h	1 year	stop	
CATALYST pump	CATA fluid section, model standard	Check the lubricant into the cup : its level (1/2 cup) and its colour (colourless)	2 mn	week	stop	P lubricant
		If the lubricant is contaminated, tighten the wetting cup on the upper packing (or change the seals of the packing, if necessary) ; do that with a depressurized pump	10 mn	month	stop	Wrench supplied
		Remove and clean the parts; change the seals and reinstall.	3 h	1 year	stop	
	CATA fluid section, model Flowmax	Remove and clean the parts; change the seals and reinstall	4 h	1 year	stop	
Flushing pump	Fluid section	Check the lubricant into the cup : its level (1/2 cup) and its colour (colourless)	2 mn	week	stop	T lubricant
		If the lubricant is contaminated, tighten the wetting cup on the upper packing (or change the seals of the packing, if necessary) ; do that with a depressurized pump	10 mn	month	stop	Wrench supplied
		Remove and clean the parts; change the seals and reinstall	2 h	1 year	stop	
Piloted valve	Piloted valve	Remove and change the cartridge	10 mn	1 year	stop	
		Change the piston packing	10 mn	1 year	stop	
Color changer	Piloted valve	Remove and change the cartridge	10 mn	1 year	stop	
		Change the piston packing	10 mn	1 year	stop	

■ TROUBLESHOOTING



For any intervention on the machine :

- Flush the circuits,
- Shut off the compressed air,
- Depressurize the hoses by triggering the gun,
- Shut off the electric supply.

If a problem occurs during the machine operation, alarms will be displayed on the screen of the machine.

Input **OK** to disable each alarm.

TROUBLES	CAUSES	SOLUTIONS
Err A	Trouble on the BASE fluid section	Check the BASE circuit : - material in the drum, - suction rod strainer, - pump valves. Clean or change. Check the CATALYST pressure towards the BASE pressure.
Err b	Trouble on the CATALYST fluid section	Check the CATALYST circuit : - material in the drum, - suction rod strainer, - pump valves. Clean or change. Check the CATALYST pressure towards the BASE pressure.
Err 1	Incorrect mixing ratio Flow incorrectly adjusted	Check the material levels in the supply drums. Check the starting of the pumps. Check the CATALYST pressure towards the BASE pressure.
Err 4	Irrelevant data capture between the ratio and the injection volume (Machine unable to give the parameters requested)	Check that the P1 parameter (ratio) and the P6 parameter (injection volume) are compatible in injection capability terms in relation to the ratio requested (refer to § 12).

■ DIAGNOSTICS

ELECTRIC

FAULTS	CHECKINGS
The machine does not switch on	Check that the isolating switch is on 'I'.
	Check that the mains supply is connected. No : connect it.
	Check that the fuse on the electric card inside the box is in working order. No : change the fuse.
	Check the electric wiring of the supply cable (bad contact or other)

MATERIAL

FAULTS	CHECKINGS
No fluid flows when passing into production or flushing mode.	Check if the valves are open : No : - Check air supply (minimum 4 bar / 58 psi), - Check the connection of the 25 pts cable, - Check the correct operating of the electrovalves. Yes : - Check the fluid pressure, - Check the static mixer.
The machine displays the correct mixing but the consumption of catalyst is too important.	Check the grounds of the machine (230V intake and ground cable of the fluid module)
The machine displays the correct mixing but the consumption of catalyst is not enough.	Check the grounds of the machine.
When the main menu page is displayed, fluid flows out when the gun is open.	Check the valves Checking of the valve : look at what is flowing -if it is solvent, change the valve (VP1) -if it is base, change the valve (VP2A) -if it is catalyst, change the valve (VP2B)

12. PROPORTION AND OUTPUT ACCORDING TO THE RATIO

■ PU 3000 PNEUMATIC, AIRMIX® AND AIRLESS VERSIONS

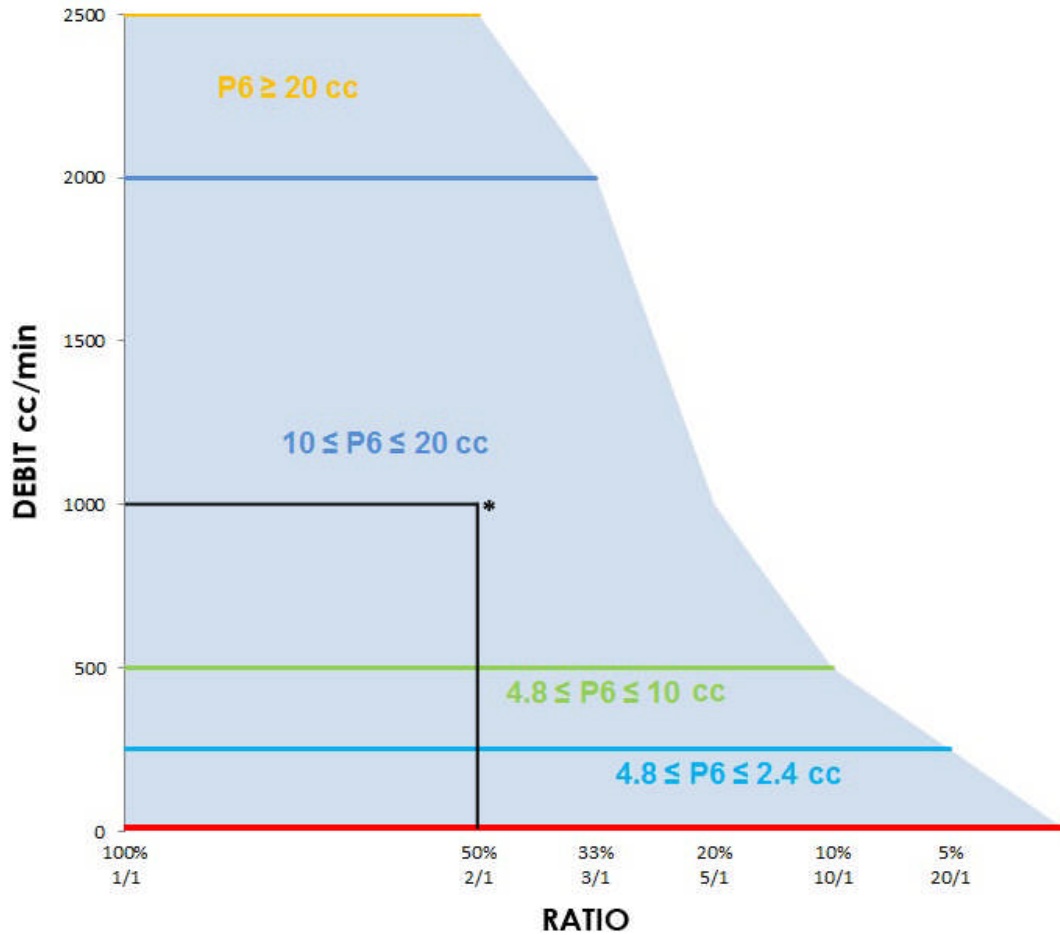

 Operating area of the PU 3000 pneumatic, Airmix® and Airless

* Example :

If you want to get a flow rate of 1000cc/min with a proportion of 2/1 (50%), then the P6 parameter (injection volume of the catalyst) must be adjust between 10 and 20cc.

Nota :

- Tests carried out with same fluid viscosity materials.

The adjustments of pressure and of injection value depend upon the fluid viscosity of the used material.

- The P6 parameter impacts the mixture, you should confirm this parameter by using the mixture on the part you want to paint.

■ PU 3000 4 L 30/1 AND 4 L 53/1 VERSIONS

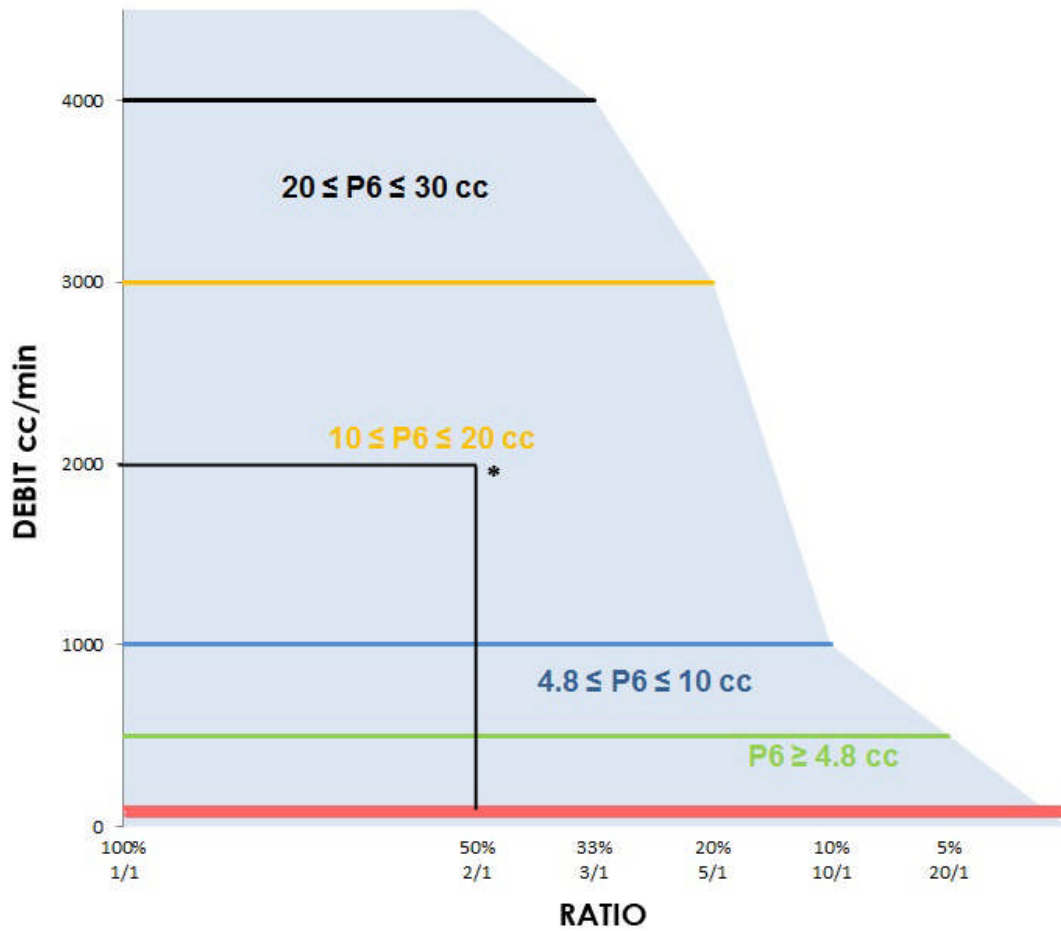

 Operating area of the PU 3000 4 L 30/1 and 4 L 53/1

* Example :

If you want to get a flow rate of 2000cc/min with a proportion of 2/1 (50%), then the P6 parameter (injection volume of the catalyst) must be adjust between 10 and 20cc.

Nota :

- Tests carried out with same fluid viscosity materials.
- The adjustments of pressure and of injection value depend upon the fluid viscosity of the used material.
- The P6 parameter impacts the mixture, you should confirm this parameter by using the mixture on the part you want to paint.

13. MIXING RATIO

A : Base

B : Catalyst

$B / A \times 100 = X\%$

Ex : A = 2.5 B = 1 $\Rightarrow 1 / 2.5 \times 100 = 40\%$

A	B	%
0.625	1	160
1	1	100
1.5	1	66.7
2	1	50
2.5	1	40
3	1	33.3
3.5	1	28.6
4	1	25
4.5	1	22.2
5	1	20
5.5	1	18.2
6	1	16.7
6.5	1	15.4
7	1	14.3
7.5	1	13.3
8	1	12.5
8.5	1	11.8
9	1	11.1
9.5	1	10.5
10	1	10

A	B	%
10.5	1	9.524
11	1	9.091
11.5	1	8.696
12	1	8.333
12.5	1	8
13	1	7.692
13.5	1	7.407
14	1	7.143
14.5	1	6.897
15	1	6.667
15.5	1	6.452
16	1	6.25
16.5	1	6.061
17	1	5.882
17.5	1	5.714
18	1	5.556
18.5	1	5.405
19	1	5.263
19.5	1	5.128
20	1	5

14. PNEUMATIC AND ELECTRIC DIAGRAMS

Refer to appendices (Doc. # 055.680.031)

SPECIFICATIONS

PU 3000 PUMP

- model Pneumatic & model Airmix®

15. FEATURES - PU 3000 PNEUMATIC

■ COMPOSITION

BASE pump	Motor :	1500 (only for PU 3000)
	Fluid section :	50 (standard)
CATALYST pump	Motor :	1500 (only for PU 3000)
	Fluid section :	50 F (Flowmax)
Flushing pump	Option :	Flushing pump, model EOS 02-C85

■ TECHNICAL FEATURES

Maximum air supply pressure	6 bar / 87 psi
Maximum fluid outlet pressure of the PU 3000	0-6 bar / 0-87 psi or 6-40 bar / 87-580 psi
Proportioning ratio / Fluid flow rate	Refer to charts (§ 12 & 13)
Electrical supply of the supply unit	115V / 230V - 10W
Air inlet connection	F 3/4 BSP (air inlet valve)
Fluid outlet connection (mixer)	F 3/4 JIC



The control box of the PU 3000 mixing machine must be installed outside the spray booth.

■ SPECIFIC PARAMETERS

Parameters	Description	Factory adjustment	Your adjustments
F3- -P4	Section of the A piston Minimum value: 1 mm ² Maximum value : 99 999 mm ²	485 (for fluid section, model 50)	
F3- -P5	Section of the B piston Minimum value: 1 mm ² Maximum value : 99 999 mm ²	490 (for fluid section, model 50 F)	

16. FEATURES - PU 3000 AIRMIX®

■ COMPOSITION

BASE pump	Motor :	3000 (only for PU 3000)
	Fluid section :	50 (standard)
CATALYST pump	Motor :	3000 (only for PU 3000)
	Fluid section :	50 F (Flowmax)
Flushing pump	Option :	Flushing pump, model EOS 30-C25

■ TECHNICAL FEATURES

Maximum air supply pressure	6 bar / 87 psi
Maximum fluid outlet pressure of the PU 3000	180 bar / 2610.5 psi
Proportioning ratio / Fluid flow rate	Refer to charts (§ 12 & 13)
Electrical supply of the supply unit	115V / 230V - 10W
Air inlet connection	F 3/4 BSP (air inlet valve)
Fluid outlet connection (mixer)	F 3/4 JIC



The control box of the PU 3000 mixing machine must be installed outside the spray booth.

■ SPECIFIC PARAMETERS

Parameters	Description	Factory adjustment	Your adjustments
F3- -P4	Section of the A piston Minimum value: 1 mm ² Maximum value : 99 999 mm ²	465 (for fluid section, model 50)	
F3- -P5	Section of the B piston Minimum value: 1 mm ² Maximum value : 99 999 mm ²	470 (for fluid section, model 50 F)	

17. DISASSEMBLY & REASSEMBLY - PU 3000 PNEUMATIC, PU 3000 AIRMIX®



CAUTION : Before any work is carried on the pump, stop the machine after carrying out flushing, shut off the compressed air supply and depressurize the circuits triggering the gun.

The pump is manufactured under the ATEX agreement and can not be modified. KREMLIN REXSON will not be held responsible for any failure to comply with that instruction.

■ MIXER

Unscrew the mixer assembly and replace it with a new one.

■ PILOTED VALVES

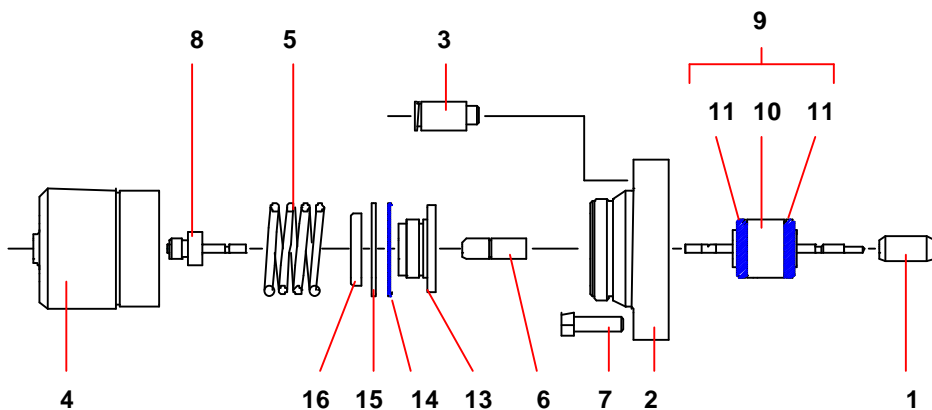

CARTRIDGE OF A FLUID VALVE (IND. 9)

Loosen the 3 screws (7) and take off the valve from the module body.

Unscrew the needle (1). Unscrew the cylinder (4).

Hold the rod strainer (6), unscrew the needle rod and remove the cartridge assembly with rod (9).

Assemble the new cartridge (9) into the cylinder support (2) pushing it until the shoulder of the cartridge rests on the shoulder of that support, then reassemble all parts of the valve in the reverse order of the disassembly.

Present the valve in front of the module body.

Center the cartridge (9) on the module body then reassemble the screws (7).

PISTON PACKING (IND. 14)

Unscrew the cylinder (4).

Remove the spring (5).

Unscrew the opening signal light (8).

Unscrew the nut (16).

Remove the support washer (15) and the packing (14).

Clean the parts and change them if necessary.

Before reassembling :

Before assembling on the piston (13), take care of shaping the cartridge lip (14) by hand as shown in the above drawing (cartridge turned up on the piston).

The nut (16) must be glued on the piston (13) with loctite adhesive (eg : Loctite 222).

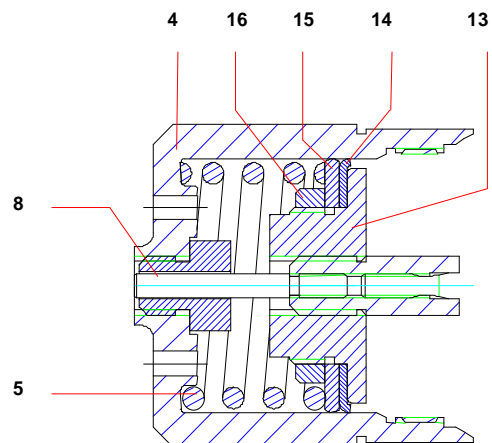

■ FLUID SECTION, MODEL 50 (BASE) (REFER TO DOC. 573.080.050)

Guards (air motor cover, coupling shields, housings ...) have been designed for safe use of the equipment.
The manufacturer will not be held responsible for bodily injury or failure and / or damage to property due to removal or partial removal of the guards.

SUCTION VALVE

Unscrew the suction valve (5) holding the cylinder (2).

The ball (10) is secured on the valve (5) by means of a circular rush (9).

Clean the parts.

Reinstall the suction valve (5) and the seal (25) changing the parts if necessary.

EXHAUST VALVE AND MOBILE PACKING

Unscrew the cylinder (2) and pull it downwards.

Unscrew the exhaust valve (6) holding the piston (3).

Take off the ball (17), the washer (12) and the seal (13).

Clean the parts.

Carry out the reassembly in the reverse order of the disassembly :

- Install the GT seal (13), the GT washer (12) and the ball (17) on the exhaust valve (6).
- Screw the exhaust valve (6) into the piston. Tighten up the seal on the exhaust valve (6).

Change the seal (8) if necessary when assembling the cylinder (2).

UPPER PACKING

Disassemble the piston rod from the motor and the piston (3) from the fluid section.

Unscrew the wetting-cup (4) by means of the wrench supplied with the pump.

Pull the piston (3) upwards to remove the seals (21 and 22) from the upper packing (18).

Reinstall the seals (21 and 22) taking care of the **direction**, the **order** and the **dimension** of assembly.

Tighten the wetting cup (4).

After reassembling the parts, fill the pump with solvent and increase the pressure to its maximum. Stop the pump and depressurize opening the drain valve.

Tighten the wetting cup (4) by means of the wrench to be in accordance with the above drawing.

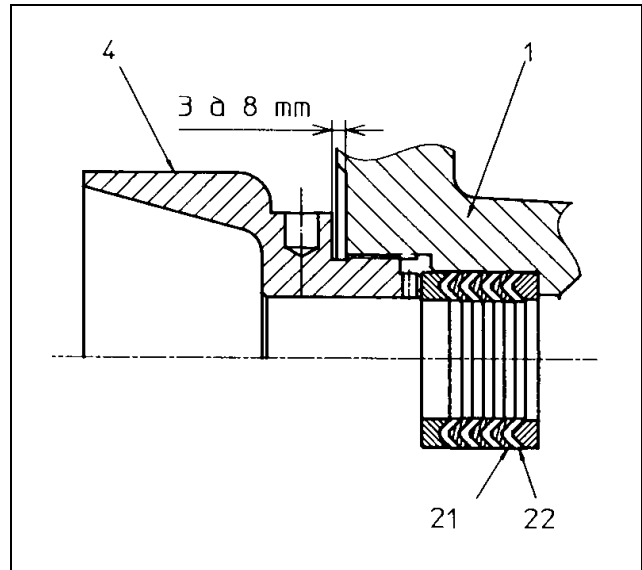

Before reassembling the different components :

- Clean the parts with the appropriate cleaning solvent,
- Install new seals if necessary after having lubricated them with PTFE grease,
- Install new parts if necessary..

ASSEMBLY INSTRUCTIONS (FLUID SECTION, MODEL 50)

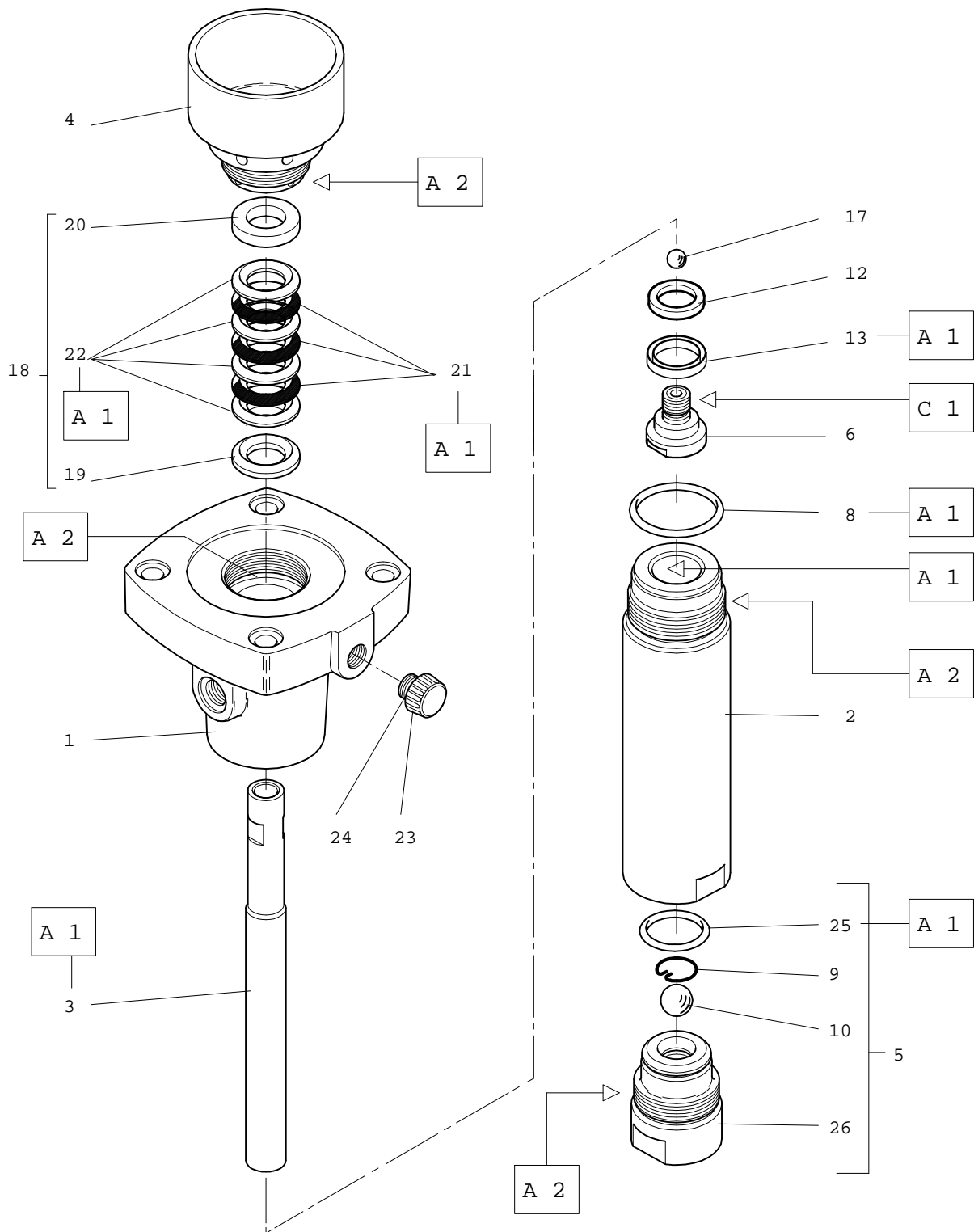

Index	Instruction	Description	Part number
A 1	PTFE grease	PTFE grease (10 ml)	560.440.101
A 2	Anti-seize grease	Grease box (450 g / 99 lb)	560.420.005
C 1	Medium strength Aneorobic Pipe sealant	Loctite 577	-

■ **FLUID SECTION, MODEL 50 F (CATALYST) (REFER TO DOC. 573.114.050)**

Guards (air motor cover, coupling shields, housings ...) have been designed for safe use of the equipment.
The manufacturer will not be held responsible for bodily injury or failure and / or damage to property due to removal or partial removal of the guards.

1 - DISASSEMBLY / ASSEMBLY OF THE FLUID SECTION PART

Unscrew the fitting nut (38) and the screws (41 and 43) to remove the connection tube (39).

SUCTION VALVE

Unscrew the suction valve (35) holding the cylinder (27).

The ball (22) is secured on the valve (35) by means of a circular rush (21).

Clean the parts.

Reinstall the suction valve (35) and the seal (23) changing parts if necessary.

EXHAUST VALVE AND MOBILE PACKING

Unscrew the cylinder (27) and pull it downwards.

Unscrew the wetting cup (33) to take off the GT seal (31) from the exhaust valve (34).

Unscrew the exhaust valve (34) holding the piston (24).

Remove the ball (32).

Clean the parts and reinstall then changing the seals if necessary.

UPPER TIGHTNESS SEAL

Unscrew the 4 screws (30).

Remove the tightness seal (28) pulling the exhaust valve (25) downwards.

Change the tightness seal (28), the O-Rings (29 and 11).

Reinstall the parts in the reverse order of the disassembly sequence.

2 - DISASSEMBLY - ASSEMBLY OF THE COUPLING (WITH BELLOWS)

That operation must be carried out after the disassembly of the fluid section part.

BELLOWS

Unscrew the nuts (14) from the coupling tie-rods.

Take off the suction flange (1) and the cylinder (2) pulling them downwards.

Remove screws (12) to separate the suction bearing (3) from the motor.

Separate the intermediate piston (9) from the motor rod.

Put aside the coupling with bellows assembly.

Disassemble the bellows' flange (4) removing the screws (13) to take off the upper part from the bellows.

Unscrew the skirt (8) to take off the lower part from the bellows.

Change the bellows (5).

Install the new bellows pushing it into skirt (8) firmly.

Insert the intermediate piston (9) inside the bellows (5) and screw the skirt at its end.

Insert the bellows and the piston (9) into the bearing (3).

Install the flange (4) into bellows (3) and tighten the whole with the screws (13).

Connect bellows-piston assembly with the motor rod and secure it to the lower support of the motor with the screws (12).

Reinstall the fluid section piston (24) on the intermediate piston (9).

Change the seals (11) then reinstall the cylinder (2) and the suction flange (1).

Install the whole on the tie-rods and tighten the nuts (14).

Before reassembling the different components :

- Clean the parts with the appropriate cleaning solvent,
- Install new seals if necessary, after having lubricated them with PTFE grease.
- Lubricate the piston and the inside of the cylinder to prevent from damaging the seals,
- Install new parts if necessary.

ASSEMBLY INSTRUCTIONS

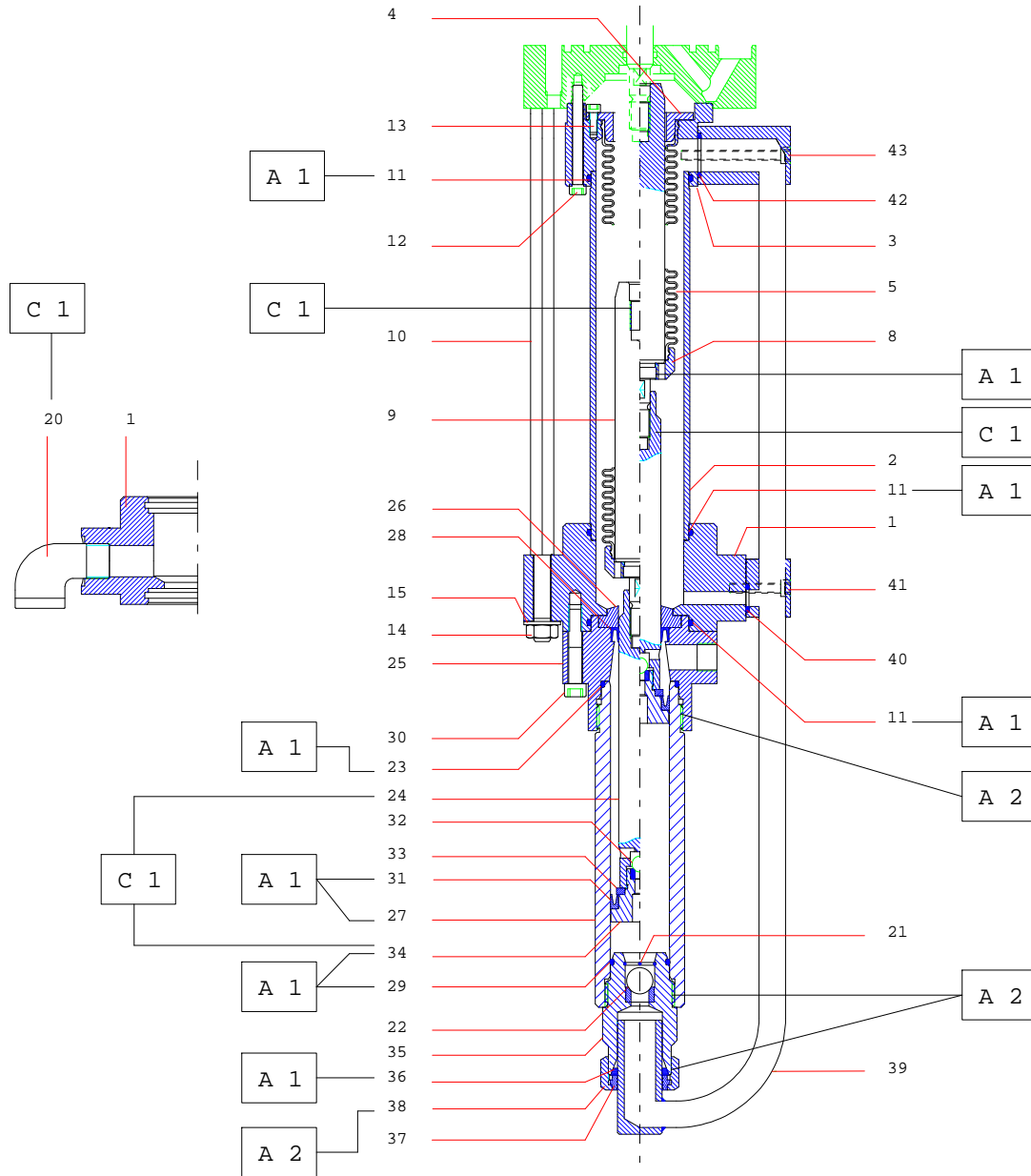

Index	Instruction	Description	Part number
A 1	PTFE grease	PTFE grease (10 ml)	560.440.101
A 2	Anti-seize grease	Grease box (450 g / 99 lb)	560.420.005
C 1	Medium strength Aneorobic Pipe sealant	Loctite 577	-

SPECIFICATIONS

PU 3000 PUMP - model Airless

18. FEATURES - PU 3000 AIRLESS

■ COMPOSITION

BASE pump	Motor :	5000 (only for PU 3000)
	Fluid section :	50 cc (standard)
CATALYST pump	Motor :	5000 (only for PU 3000)
	Fluid section :	50 cc (standard)
Flushing pump	Option :	Flushing pump, model EOS 30-C25

■ TECHNICAL FEATURES

Maximum air supply pressure	6 bar / 87 psi
Maximum fluid outlet pressure of the PU 3000	360 bar / 5222 psi
Proportioning ratio / Fluid flow rate	Refer to charts (§ 12 & 13)
Electrical supply of the supply unit	115V / 230V - 10W
Air inlet connection	F 3/4 BSP (air inlet valve)
Fluid outlet connection (mixer)	F 3/4 JIC



The control box of the PU 3000 mixing machine must be installed outside the spray booth.

■ SPECIFIC PARAMETERS

Parameters	Description	Factory adjustment	Your adjustments
F3- -P4	Section of the A piston Minimum value : 1 mm2 Maximum value : 99 999 mm2	555 (for fluid section, model 50cc)	
F3- -P5	Section of the B piston Minimum value : 1 mm2 Maximum value : 99 999 mm2	555 (for fluid section, model 50cc)	

19. DISASSEMBLY & REASSEMBLY - PU 3000 AIRLESS



CAUTION : Before any work is carried on the pump, stop the machine after carrying out flushing, shut off the compressed air supply and depressurize the circuits triggering the gun.

The pump is manufactured under the ATEX agreement and can not be modified. KREMLIN REXSON will not be held responsible for any failure to comply with that instruction.

■ MIXER

Unscrew the mixer assembly and replace it with a new one.

■ ASI 40 VALVES (REFER TO DOC. 573.062.050)

FLUID PACKING (IND. 22) AND NEEDLE WITH BALL (IND. 37)

Unscrew the diaphragm (9), the seat-holder assembly (17).

Take off the 2 screws (13).

Disassemble the needle holder (23) from the needle strainer (6) to remove the front body (1) from the gun.

Take off the circlip (26) holding the fluid packing (22).

Remove the fluid packing (22) pulling the needle frontwards.

Unscrew the ball needle (37) from the needle holder (23).

Change the fluid packing and its seal (24).

Clean the front part of the gun.

When assembling, drive fluid packing (22) by pushing it from the front part to the rear part of the body (1) until the packing shoulder comes to lean against the shoulder located inside the gun.

Then, secure the fluid packing by means of the circlip (26).

Reinstall the ball needle (37), the screws (13), the seat-holder assembly (17), the diaphragm (9), the tip and the coupling nut (8).

PISTON ASSEMBLY (IND. 27)

Unscrew the 4 screws (11).

Remove the spring guide (3) and the cylinder (2).

Take off the spring (7), the spring support (33).

Unscrew the nut (31).

Remove the washer (30) and the piston packing (29).

Clean the parts and change them if necessary.

Nota : Before inserting the piston assembly (27) into the cylinder, the packing lip (29) must be shaped by hand as shown opposite (cartridge turned up on the piston).

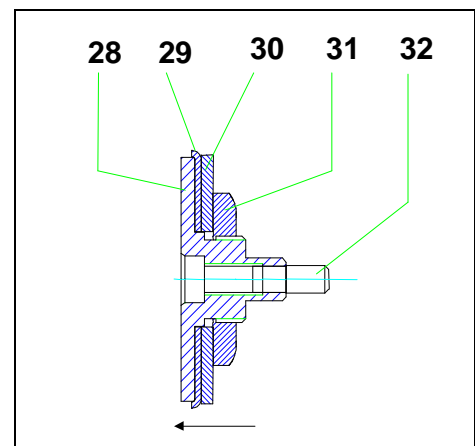

AIR PACKING (IND. 34)

Take off the back part of the gun and remove the piston as explained before.

Remove the air packing (34).

Replace the packing seal (36) or the air packing assembly.

Nota : when changing the ASI 40 valve from the PU 3000 fluid equipment, take off the fittings from the spare valve delivered, then install it on the fluid equipment.

■ FLUID SECTION, MODEL ALTO 50CC (BASE & CATALYST) (REFER TO DOC. 573.395.050)



WARNING!

Before any action on the pump, shut off the compressed air supply and depressurize the systems by triggering the spray gun.

Guards (air motor cover, coupling shields, housings ...) have been designed for safe use of the equipment.
The manufacturer will not be held responsible for bodily injury or failure and / or damage to property due to removal or partial removal of the guards.

Disassembly of the pump

- Unscrew the 2 nuts (22) and put aside the flange (20), the tie-rods (21) and the protective housing (23),
- Clamp the pump horizontally through the body (2) into a vice,
- Unscrew the valve body assembly (14),
- Take off the piston (8) downwards,
- Put aside the cylinder (7).

Lower valve

- Push on the ball (16) to remove the spacer (17),
 - Take off the seat (15), the seal (19) and the pin (18),
 - Put aside the seal (13),
 - Clean the parts, check them if they are not worn or damaged.
- Reinstall the parts in the reverse order of the disassembly sequence.

Cup seals

- Unscrew the cup nut (1),
 - Take off the washers (3 & 5),
 - Put aside the seals: PTFEG seals (4a) & UHMW seals (4b),
 - Clean the parts, check them if they are not worn or damaged.
- Reinstall the parts in the reverse order of the disassembly sequence

Piston head seals

- Unscrew the seat (10),
- Take off the ball (11), the washers (3 & 5) and the seals (12),
- Change the seals : PTFE G seals (12a) & UHMW seals (12b),
- Clean the parts, check them if they are not worn or damaged.

Complete assembly of the fluid section

- Lubricate the cup seals and the piston head seals,
- Slide the piston rod assembly (8) inside the body (2), push it upwards,
- Screw the cylinder (7) (to stop) into the body (2),
- Screw the valve body assembly (14) to stop, tighten slightly,
- Reinstall the protective housing (23), the connection flange (20) and the tie-rods (21). Screw the two nuts (22),
- Assemble the pump to the pneumatic motor.

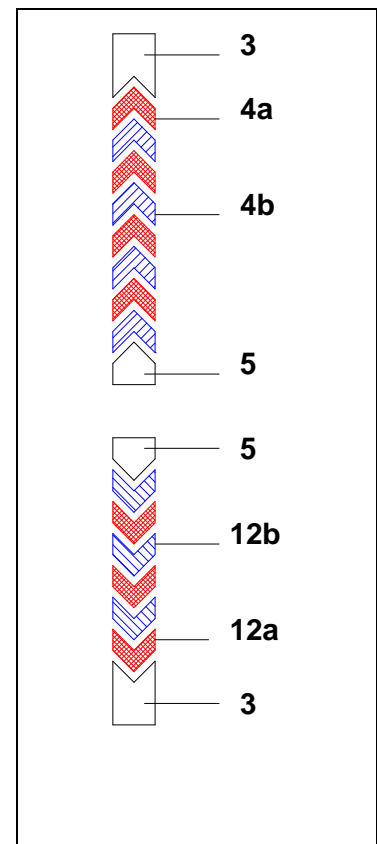

Before intervening on the equipment :

- Clean the parts with the appropriate cleaning solvent,
- Install new seals if necessary, after having lubricated them with grease.
- Lubricate the piston and the inside of the cylinder to prevent from damaging the seals,
- Install new parts if necessary.

ASSEMBLY INSTRUCTIONS (FLUID SECTION, MODEL 50cc)

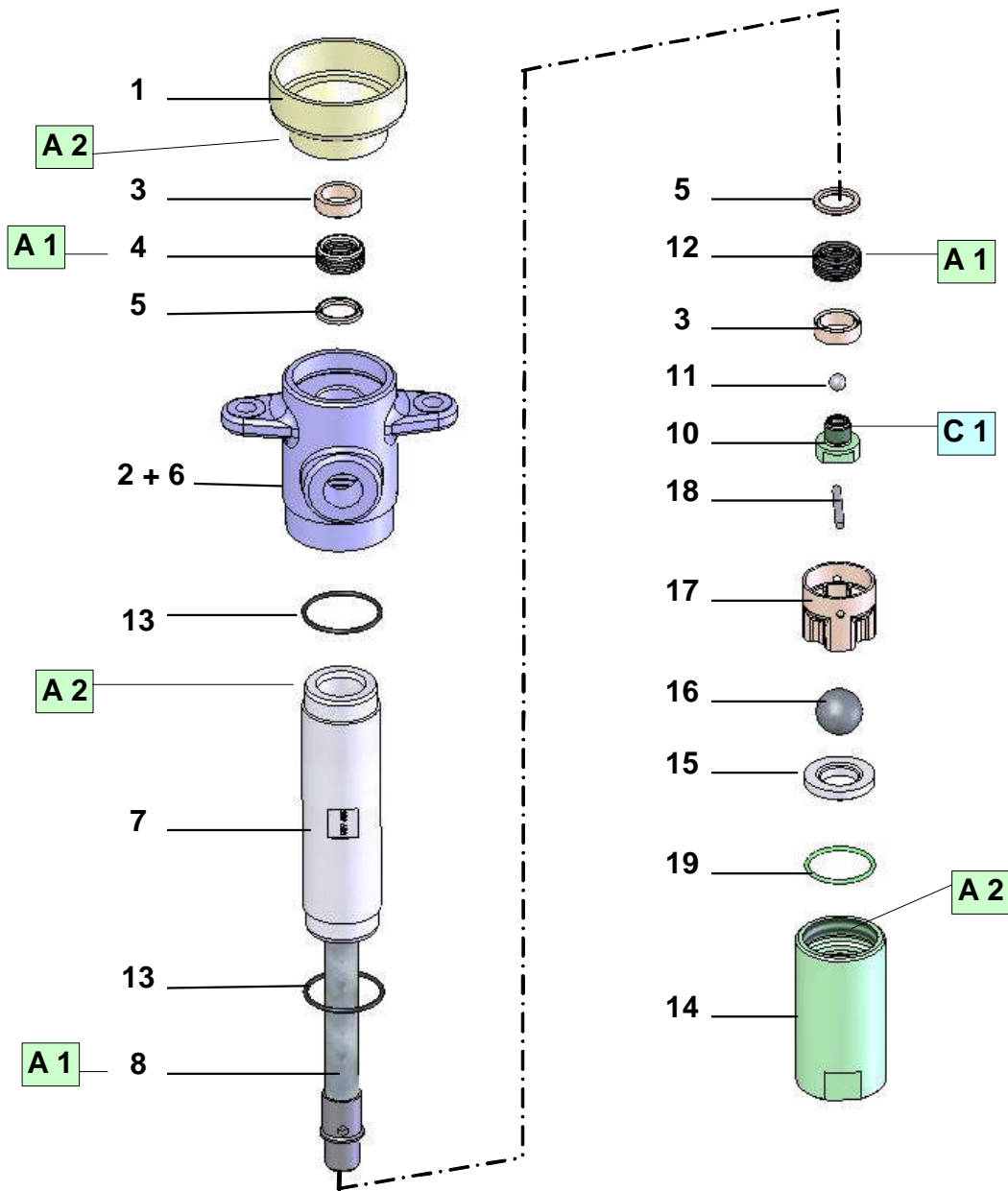

Index	Instruction	Description	Part number
A 1	PTFE grease	PTFE grease (10 ml)	560.440.101
A 2	Anti-seize grease	Grease box (450 g / 99 lb)	560.420.005
C 1	Medium strength Aneorobic Pipe sealant	Loctite 577	-

SPECIFICATIONS

PU 3000 PUMP - model 4 L 30/1

20. FEATURES - PU 3000 4 L 30/1

■ COMPOSITION

BASE pump	Motor :	5000 (only for PU 3000)
	Fluid section :	225cc (standard)
CATALYST pump	Motor :	5000 (only for PU 3000)
	Fluid section :	225cc (standard)
Flushing pump	Option :	Flushing pump, model EOS 30-C25

■ TECHNICAL FEATURES

Maximum air supply pressure	6 bar / 87 psi
Maximum fluid outlet pressure of the PU 3000	180 bar / 2610.5 psi
Proportioning ratio / Fluid flow rate	Refer to charts (§ 12 & 13)
Electrical supply of the supply unit	115V / 230V - 10W
Air inlet connection	F 3/4 BSP (air inlet valve)
Fluid outlet connection (mixer)	F 3/4 JIC



The control box of the PU 3000 mixing machine must be installed outside the spray booth.

■ SPECIFIC PARAMETERS

Parameters	Description	Factory adjustment	Your adjustments
F3- -P4	Section of the A piston Minimum value: 1 mm ² Maximum value : 99 999 mm ²	1010 (for fluid section, model 225cc)	
F3- -P5	Section of the B piston Minimum value: 1 mm ² Maximum value : 99 999 mm ²	1010 (for fluid section, model 225cc)	

21. DISASSEMBLY & REASSEMBLY - PU 3000 4 L 30/1



CAUTION : Before any work is carried on the pump, stop the machine after carrying out flushing, shut off the compressed air supply and depressurize the circuits triggering the gun.

The pump is manufactured under the ATEX agreement and can not be modified. KREMLIN REXSON will not be held responsible for any failure to comply with that instruction.

■ MIXER

Unscrew the mixer assembly and replace it with a new one.

■ ASI 40 VALVES (REFER TO DOC. 573.062.050)

FLUID PACKING (IND. 22) AND NEEDLE WITH BALL (IND. 37)

Unscrew the diaphragm (9), the seat-holder assembly (17).

Take off the 2 screws (13).

Disassemble the needle holder (23) from the needle strainer (6) to remove the front body (1) from the gun.

Take off the circlip (26) holding the fluid packing (22).

Remove the fluid packing (22) pulling the needle frontwards.

Unscrew the ball needle (37) from the needle holder (23).

Change the fluid packing and its seal (24).

Clean the front part of the gun.

When assembling, drive fluid packing (22) by pushing it from the front part to the rear part of the body (1) until the packing shoulder comes to lean against the shoulder located inside the gun.

Then, secure the fluid packing by means of the circlip (26).

Reinstall the ball needle (37), the screws (13), the seat-holder assembly (17), the diaphragm (9), the tip and the coupling nut (8).

PISTON ASSEMBLY (IND. 27)

Unscrew the 4 screws (11).

Remove the spring guide (3) and the cylinder (2).

Take off the spring (7), the spring support (33).

Unscrew the nut (31).

Remove the washer (30) and the piston packing (29).

Clean the parts and change them if necessary.

Nota : Before inserting the piston assembly (27) into the cylinder, the packing lip (29) must be shaped by hand as shown opposite (cartridge turned up on the piston).

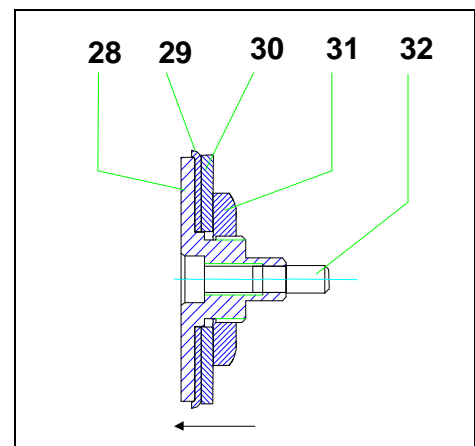

AIR PACKING (IND. 34)

Take off the back part of the gun and remove the piston as explained before.

Remove the air packing (34).

Replace the packing seal (36) or the air packing assembly.

Nota : when changing the ASI 40 valve from the PU 3000 fluid equipment, take off the fittings from the spare valve delivered, then install it on the fluid equipment.

■ FLUID SECTION, MODEL ALTO 225CC (BASE & CATALYST) (REFER TO DOC. 573.451.050)

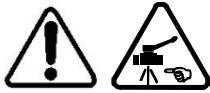

WARNING!

Before any action on the pump, shut off the compressed air supply and depressurize the systems by triggering the spray gun.

Guards (air motor cover, coupling shields, housings ...) have been designed for safe use of the equipment.
The manufacturer will not be held responsible for bodily injury or failure and / or damage to property due to removal or partial removal of the guards.

Disassembly of the pump

- Unscrew the 2 nuts (16) and put aside the flange (1), the tie-rods (10) and the protective housing (4),
- Clamp the pump horizontally through the body (7) into a vice,
- Unscrew the valve body assembly (23),
- Take off the piston (11) downwards,
- Put aside the cylinder (21).

Lower valve

- Push on the ball (19) to remove the spacer (18),
 - Take off the seat (20), the seal (22) and the pin (24),
 - Put aside the seal (9),
 - Clean the parts, check them if they are not worn or damaged.
- Reinstall the parts in the reverse order of the disassembly sequence.

Cup seals

- Unscrew the cup nut (5),
 - Take off the washers (6 & 13),
 - Put aside the seals: PE seals (12a) & PTFE G seals (12b)
 - Clean the parts, check them if they are not worn or damaged.
- Reinstall the parts in the reverse order of the disassembly sequence

Piston head seals

- Unscrew the seat (17),
- Take off the ball (15), the washers (6 & 13) and the seals (12),
- Change the seals: PE seals (12a) & PTFE G seals (12b),
- Clean the parts, check them if they are not worn or damaged.

Complete assembly of the fluid section

- Lubricate the cup seals and the piston head seals,
- Slide the piston rod assembly (11) inside the body (7), push it upwards,
- Screw the cylinder (21) (to stop) into the body (7),

- Screw the valve body assembly (23) to stop, tighten slightly,
- Reinstall the protective housing (4), the connection flange (1) and the tie-rods (10). Screw the two nuts (16),
- Assemble the pump to the pneumatic motor.

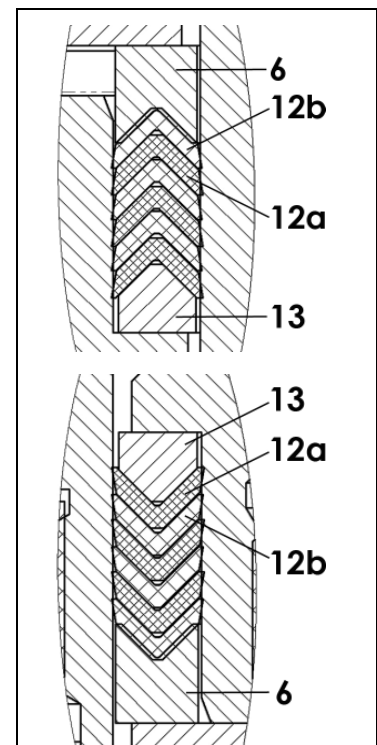

Before intervening on the equipment :

- Clean the parts with the appropriate cleaning solvent,
- Install new seals if necessary, after having lubricated them with grease.
- Lubricate the piston and the inside of the cylinder to prevent from damaging the seals,
- Install new parts if necessary.

ASSEMBLY INSTRUCTIONS (FLUID SECTION, MODEL 225CC)

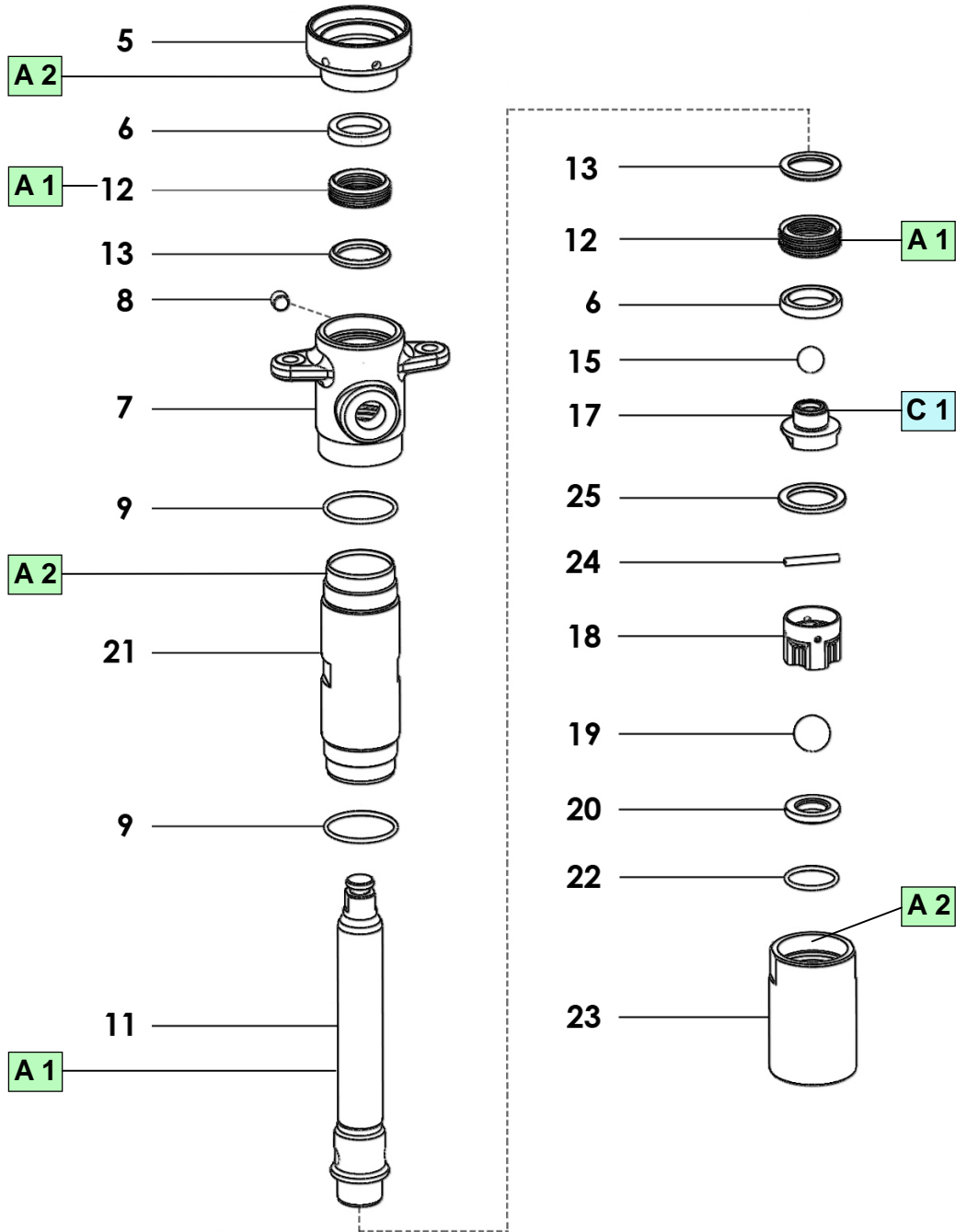

Index	Instruction	Description	Part number
A 1	PTFE grease	PTFE grease (10 ml)	560.440.101
A 2	Anti-seize grease	Grease box (450 g / 99 lb)	560.420.005
C 1	Medium strength Aneorobic Pipe sealant	Loctite 577	-

SPECIFICATIONS

PU 3000 PUMP - model 4 L 53/1

22. FEATURES - PU 3000 4 L 53/1

■ COMPOSITION

BASE pump	Motor :	7000 (only for PU 3000)
	Fluid section :	227cc (standard)
CATALYST pump	Motor :	7000 (only for PU 3000)
	Fluid section :	227cc (standard)
Flushing pump	Option :	Flushing pump, model EOS 30-C25

■ TECHNICAL FEATURES

Maximum air supply pressure	6 bar / 87 psi
Maximum fluid outlet pressure of the PU 3000	360 bar / 5222 psi
Proportioning ratio / Fluid flow rate	Refer to charts (§ 12 & 13)
Electrical supply of the supply unit	115V / 230V - 10W
Air inlet connection	F 3/4 BSP (air inlet valve)
Fluid outlet connection (mixer)	F 3/4 JIC



The control box of the PU 3000 mixing machine must be installed outside the spray booth.

■ SPECIFIC PARAMETERS

Parameters	Description	Factory adjustment	Your adjustments
F3- -P4	Section of the A piston Minimum value : 1 mm ² Maximum value : 99 999 mm ²	1025 (for fluid section, model 227cc)	
F3- -P5	Section of the B piston Minimum value : 1 mm ² Maximum value : 99 999 mm ²	1025 (for fluid section, model 227cc)	

23. DISASSEMBLY & REASSEMBLY - PU 3000 4 L 53/1



CAUTION : Before any work is carried on the pump, stop the machine after carrying out flushing, shut off the compressed air supply and depressurize the circuits triggering the gun.

The pump is manufactured under the ATEX agreement and can not be modified. KREMLIN REXSON will not be held responsible for any failure to comply with that instruction.

■ MIXER

Unscrew the mixer assembly and replace it with a new one.

■ ASI 40 VALVES (REFER TO DOC. 573.062.050)

FLUID PACKING (IND. 22) AND NEEDLE WITH BALL (IND. 37)

Unscrew the diaphragm (9), the seat-holder assembly (17).

Take off the 2 screws (13).

Disassemble the needle holder (23) from the needle strainer (6) to remove the front body (1) from the gun.

Take off the circlip (26) holding the fluid packing (22).

Remove the fluid packing (22) pulling the needle frontwards.

Unscrew the ball needle (37) from the needle holder (23).

Change the fluid packing and its seal (24).

Clean the front part of the gun.

When assembling, drive fluid packing (22) by pushing it from the front part to the rear part of the body (1) until the packing shoulder comes to lean against the shoulder located inside the gun.

Then, secure the fluid packing by means of the circlip (26).

Reinstall the ball needle (37), the screws (13), the seat-holder assembly (17), the diaphragm (9), the tip and the coupling nut (8).

PISTON ASSEMBLY (IND. 27)

Unscrew the 4 screws (11).

Remove the spring guide (3) and the cylinder (2).

Take off the spring (7), the spring support (33).

Unscrew the nut (31).

Remove the washer (30) and the piston packing (29).

Clean the parts and change them if necessary.

Nota : Before inserting the piston assembly (27) into the cylinder, the packing lip (29) must be shaped by hand as shown opposite (cartridge turned up on the piston).

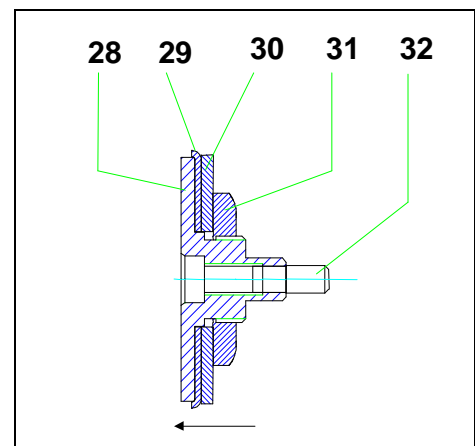

AIR PACKING (IND. 34)

Take off the back part of the gun and remove the piston as explained before.

Remove the air packing (34).

Replace the packing seal (36) or the air packing assembly.

Nota : when changing the ASI 40 valve from the PU 3000 fluid equipment, take off the fittings from the spare valve delivered, then install it on the fluid equipment.

■ FLUID SECTION, MODEL MAJOR 227CC # 105 174 01 07 (BASE & CATALYST)
(REFER TO DOC. 573.447.050)

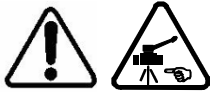

WARNING!

Before any action on the pump, shut off the compressed air supply and depressurize the systems by triggering the spray gun.

**Guards (air motor cover, coupling shields, housings ...) have been designed for safe use of the equipment.
The manufacturer will not be held responsible for bodily injury or failure and / or damage to property due to removal or partial removal of the guards.**

Disassembly of the pump

- Unscrew the 4 nuts (16) and put aside the flange (1), the tie-rods (14) and the protective housing (4),
- Clamp the pump horizontally through the body (7) with a vice,
- Unscrew the foot valve body assembly (26),
- Take off the piston rod (15) downwards,
- Put aside the cylinder (10).

Lower valve

- Unscrew the body of the foot valve body (26),
- Take off the ball cage (19) and the ball (22),
- Take off the seat (23) and the seals (24 & 25).
- Clean all the parts, check them; if there are damaged or worn, change them.

Reinstall the parts in the reverse order of the disassembly sequence.

Cup seals

Nota : the pump body (7) consists of a cartridge (7b) to make easier the changing of the seals.

- Unscrew the cup nut (5),
- Take off the 10 screws (7d) that tighten the cartridge (7b) in the body (7a),
- Take off the cartridge (7b) screwing the extractors in the 2 M8 holes in the cartridge,
- Take off the washers (6 & 12), and the seals (11),
- Change the seals: PE seals (11b) & PTFE G seals (11d),
- Change the seal (7c).

Clean all the parts, check them; if there are damaged or worn, change them.

Reinstall the parts in the reverse order of the disassembly sequence.

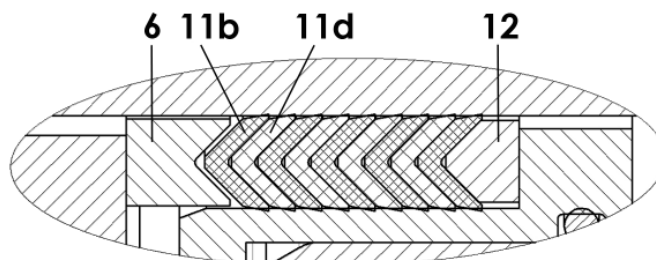
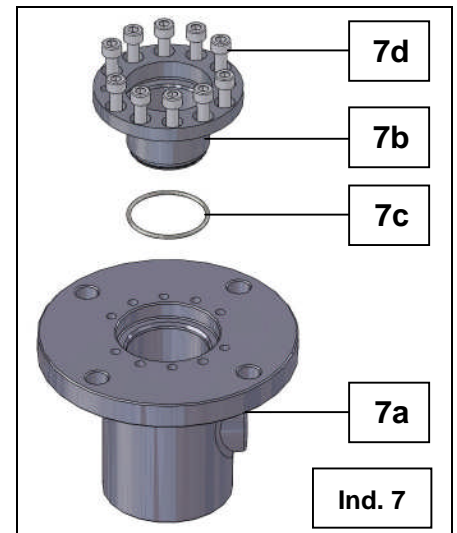

Piston rod seals

- Unscrew the seat (18),
 - Take off the ball (17), the washers (12 & 16), the seals: PE seals (11b) & PTFE G seals (11d) and the adjustment blocks (27),
 - Clean all the parts, check them; if there are damaged or worn, change them.
- Reinstall the parts in the reverse order of the disassembly sequence.

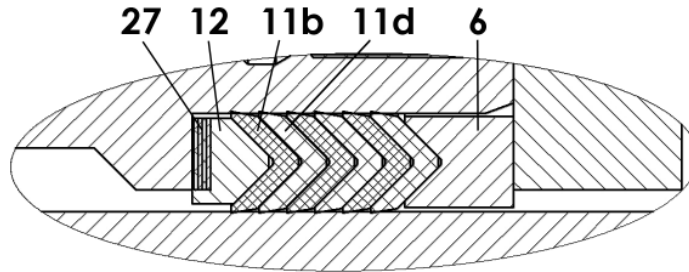

Complete assembly of the fluid section

- Lubricate the cup seals and piston rod seals,
- Slide the piston rod assembly (15) inside the body (7), push it upwards,
- Screw the cylinder (10) into the body (7),
- Screw the foot valve body assembly (26). Tighten slightly,
- Reinstall the protective housing (4), the connecting flange (1) and the tie-rods (14). Screw the 4 nuts (16).
- Couple the fluid section to the pneumatic motor.

Before intervening on the equipment :

- **Clean the parts with the appropriate cleaning solvent,**
- **Install new seals if necessary after having lubricated them,**
- **Lubricate the piston and the inside of the cylinder to prevent from damaging the seals,**
- **Install new parts if necessary.**

Adjustment of the suction valve ball cage screw :

Depending upon the fluid viscosity to be pumped, adjust the height of the screw (19c) to increase the ball up motion.

Lock the screw on the lock nut (19b).

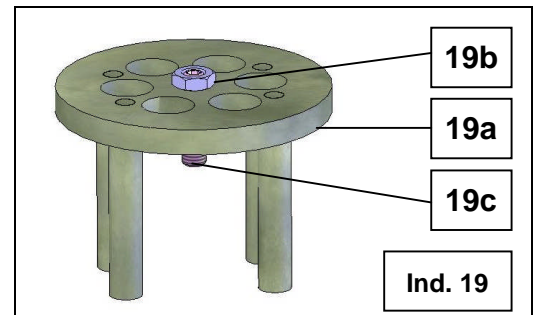

ASSEMBLY INSTRUCTIONS (FLUID SECTION, MODEL 227CC)

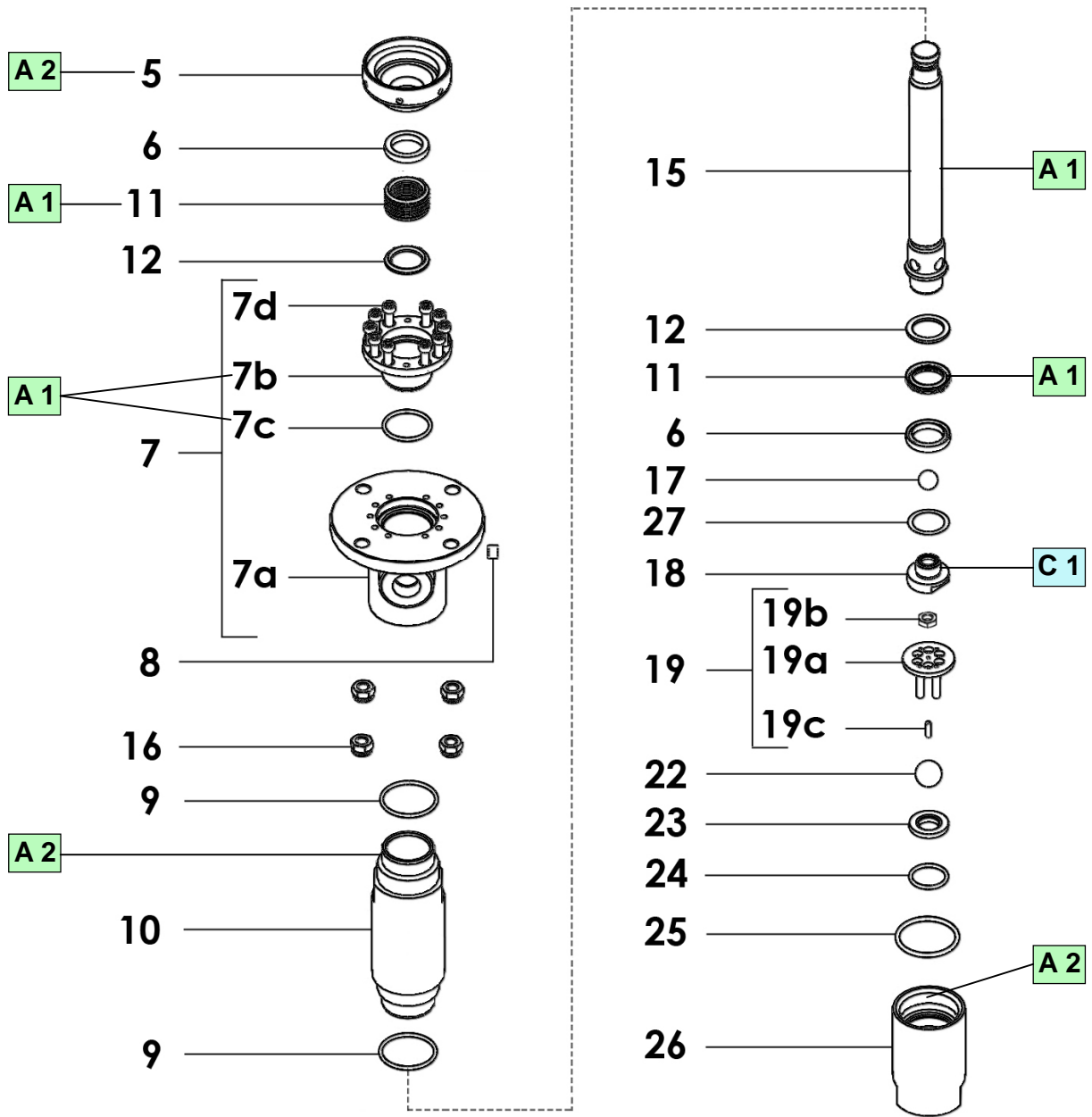

Index	Instruction	Description	Part number
A 1	PTFE grease	PTFE grease (10 ml)	560.440.101
A 2	Anti-seize grease	Grease box (450 g / 99 lb)	560.420.005
C 1	Medium strength Aneorobic Pipe sealant	Loctite 577	-

Doc. 573.453.050 Date/Datum/Fecha : 14/02/14 Annule/Cancelés/ Ersetzt/Anula :	Modif. / Änderung :	Pièces de rechange Spare parts list Ersatzteilliste Piezas de repuesto
---	----------------------------	---

MACHINE DE DOSAGE ELECTRONIQUE - ELECTRONIC DOSING MACHINE
ELEKTRONISCHE 2K-ANLAGE - MÁQUINA DE DOSIFICACIÓN ELECTRÓNICA
PU 3000 4 L 53/1 # 155.680.150

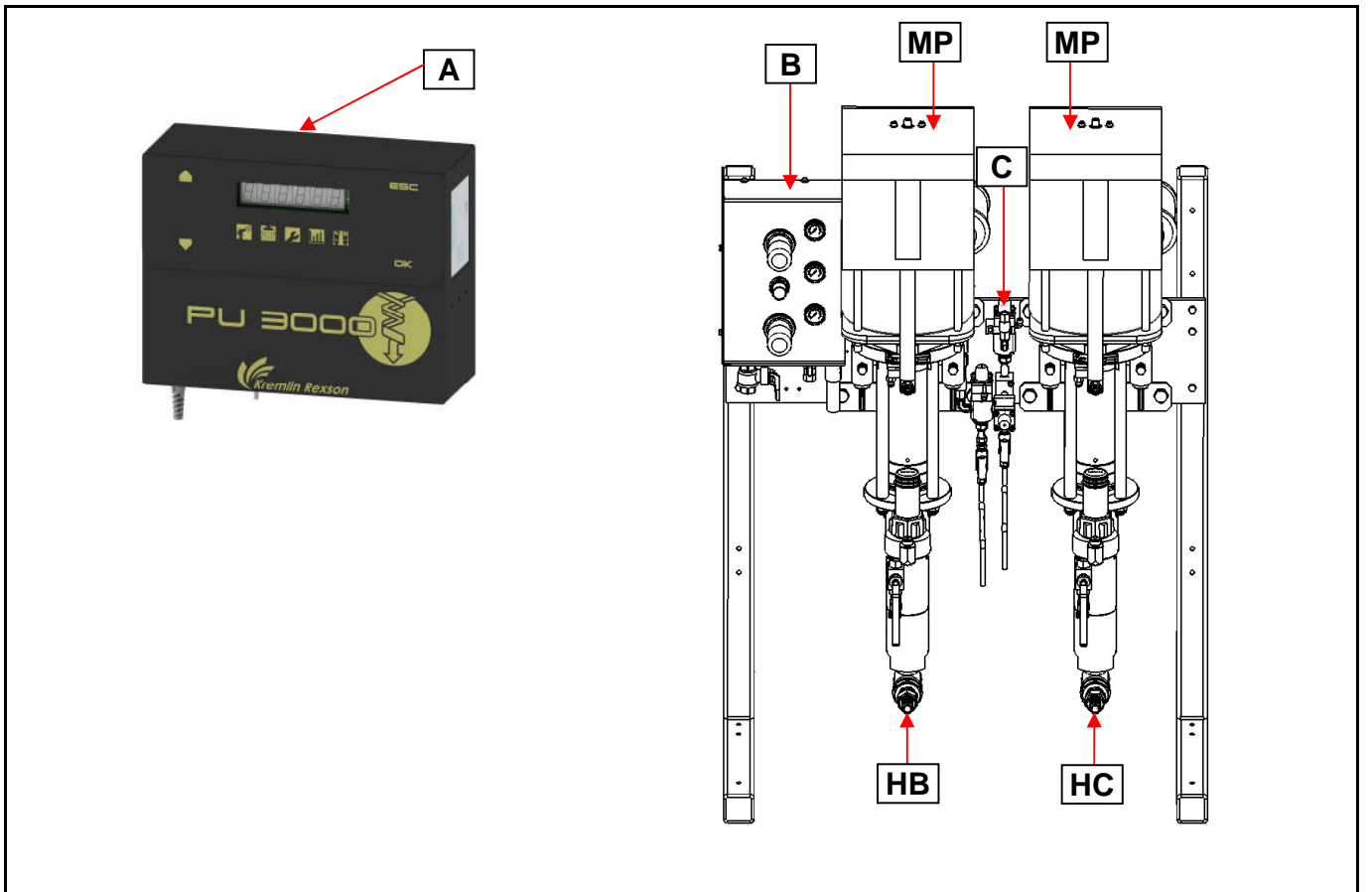

MP Moteur pneumatique / Air motor / Luftmotor / Motor neumático 7000 PU	HB Hydraulique Base / Base fluid section / Basis-Hydraulikteil / Hidráulica Base 227 cc	HC Hydraulique Catalyseur / Catalyst fluid section / Härter-Hydraulikteil / Hidráulica Catalizador
# 155.680.129 (📄 Doc. 573.450.050)	# 105.174.01.07 (📄 Doc. 573.447.050)	

Option / On request / Optionen / Opción :

PS : Pompe de rinçage / Flushing pump / Spülpumpe / Bomba de limpieza

A	COFFRET DE COMMANDE / CONTROL CABINET / STEUERUNGSGEHÄUSE / ARMARIO DE MANDO # 155.680.040
----------	---

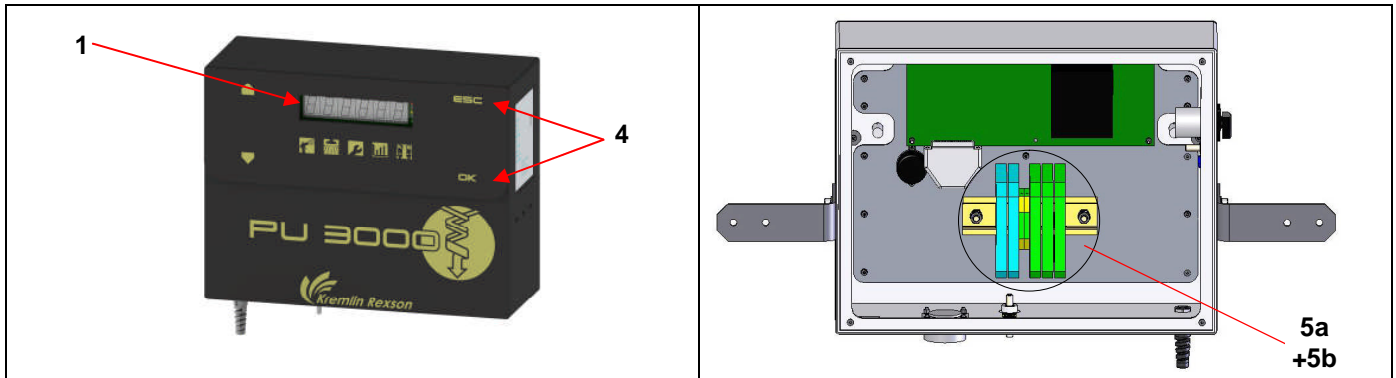

Ind	#	Désignation	Description	Bezeichnung	Denominación	Qté
*1	155 680 048	Carte μ avec afficheur	μ card with display unit	Elektronische Karte mit integriertem Display	Carta μ con visualizador	1
-	901 280 192	Interrupteur	Switch	Schalter	Interruptor	1
*4	155 660 925	Ensemble capteur et aimant	Sensor and magnet assembly	Sensor und Magnet Einheit	Conjunto captador y imán	4
5a	903 050 530	Barrière Zener Z 728	Z 728 Zener barrier	Zener Barriere Z 728	Barrera Zener, tipo Z 728	3
5b	903 050 531	Barrière Zener Z 764	Z 764 Zener barrier	Zener Barriere Z 764	Barrera Zener, tipo Z 764	2
-	901 280 193	Buzzer 24V - 100 db	Buzzer 24V - 100 db	Summer 24V - 100 dB	Sirena 24V - 100 db	1

B	EQUIPEMENT D'AIR / AIR SUPPLY / LUFTAUSRÜSTUNG / EQUIPO DE AIRE
----------	--

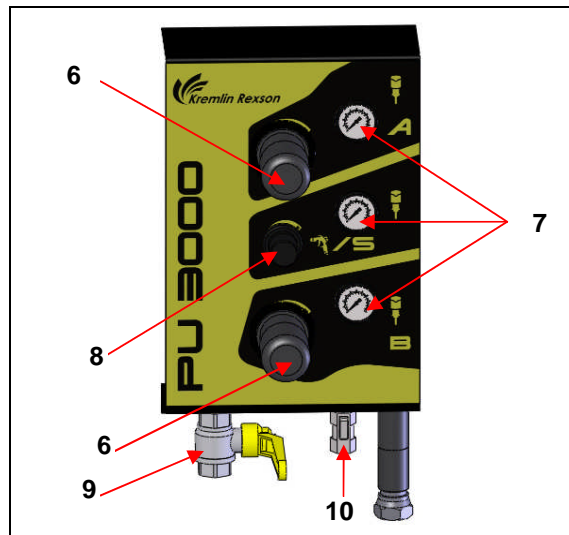

Ind	#	Désignation	Description	Bezeichnung	Denominación	Qté
*6	91 530	Régulateur d'air	Air regulator	Druckminderer	Manorreductor de aire	2
*7	910 011 205	Manomètre 0-10 bar	Gauge, 0-10 bar/145 psi	Manometer, 0-10 bar	Manómetro, tipo 0-10 bar	3
*8	903 130 601	Régulateur d'air	Air regulator	Druckminderer	Manorreductor de aire	1
9	91 458	Vanne FF 3/4" G à décompression	Valve, model FF 3/4" G	Absperrhahn IG 3/4" G	Válvula, tipo HH 3/4" G	1
10	903 090 806	Vanne F 1/4" G	Valve, model F 1/4" G	Absperrhahn IG 1/4" G	Válvula, tipo H 1/4" G	2

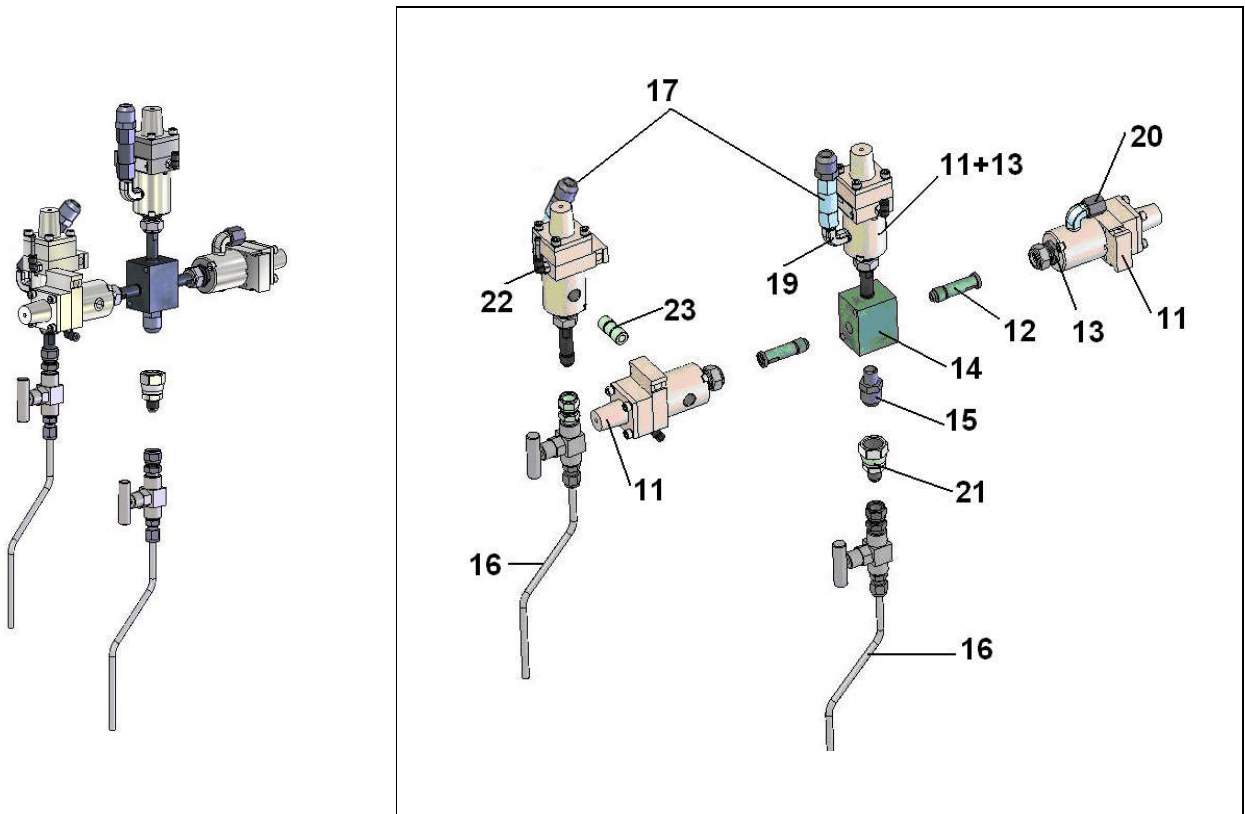

Ind	#	Désignation	Description	Bezeichnung	Denominación	Qté
*11	129 980 500	Vanne ASI 40 (Doc. 573.062.050)	ASI 40 valve (Doc. 573.062.050)	Ventil ASI40 (Dok. 573.062.050)	Válvula ASI 40 (Doc. 573.062.050)	3
12	055 680 063	Raccord pour ASI (M 1/2 JIC)	Fitting for ASI (M 1/2 JIC)	Nippel (AG 1/2 JIC)	Racor para ASI (M 1/2 JIC)	4
*13	149 949 901	Joint (pochette de 10)	Seal (pack of 10)	Dichtung (10 St.)	Junta (Bolsa de 10)	3
14	055 660 070	Bloc d'injection	Injection unit	Injektions-Block	Bloque de inyección	1
15	905 210 512	Raccord inox M 1/4 NPT - M 3/4 JIC	Fitting, stainless steel, model double male, 1/4 NPT - 3/4 JIC (# 8 JIC)	Anschluss aus Edelstahl, AG 1/4 NPT - AG 3/4 JIC	Racor de inox, tipo M 1/4 NPT - M 3/4 JIC	1
*16	155 680 025	Ensemble robinet pointeau	Needle-valve assembly	Nadelventil-Einheit	Conjunto grifo-aguja	2
*17	903 160 512	Clapet AR inox 400 bar	Non-return valve, stainless steel, 400 bar / 5801.2 psi	Rückschlagventil aus Edelstahl, 400 bar	Válvula anti-retorno de inox, 400 bar	2
19	905 200 404	Coude 400 bar M 1/4 NPT	Elbow, model M 1/4 NPT 400 bar / 5801.2 psi	Winkelnippel 400 bar AG 1/4 NPT	Codo, tipo 400 bar, M 1/4 NPT	2
20	905 210 602	Coude inox M 1/2 JIC - M1/4 NPT	Elbow, stainless steel, model double male, 1/2 JIC - 1/4 NPT	Winkelnippel aus Edelstahl AG 1/2 JIC - AG1/4 NPT	Codo de inox, tipo M 1/2 JIC - M 1/4 NPT	1
21	905 160 219	Raccord tournant inox M 1/2 JIC - F 3/4 JIC	Swivel fitting, model M 1/2 JIC - F 3/4 JIC (stainless steel)	Drehanschluss aus Edelstahl AG 1/2 JIC - IG 3/4 JIC	Racor giratorio de inox, tipo M 1/2 JIC - H 3/4 JIC	1
22	905 120 926	Coude M 1/8" G - T 2,7 x 4	Elbow, model M 1/8" G - T 2,7 x 4	Winkelnippel AG 1/8" G - T 2,7 x 4	Codo, tipo M 1/8" G - T 2,7 x 4	4

Ind	#	Désignation	Description	Bezeichnung	Denominación	Qté
23	905 200 504	Mamelon inox	Nipple, stainless steel	Nippel, Edelstahl	Pivote de centrado	1
*	155 660 080	Ensemble mélangeur souple (1m - 375 bar)	Flexible mixer assembly (1 m - 375 bar / 5440 psi)	Mischer-Schlauch mit Anschlüssen (1m - 375 bar)	Conjunto mezclador flexible (1m - 375 bar)	1
-	906 314 217	Raccord inox M 3/4 JIC - M 1/2 JIC	Fitting, stainless steel, model double male, # 8 JIC - # 5 JIC	Anschluss aus Edelstahl, AG 3/4 JIC - AG 1/2 JIC	Racor de inox, tipo M 3/4 JIC - M 1/2 JIC	1
*	050 450 905	Tuyau produit (Ø 9,5 mm, long. 1 m, 375 bar)	Fluid hose (3/8" dia, length : 1 m / 39.37", 375 bar / 5439 psi)	Materialschlauch (Ø 9,5 mm, Länge : 1 m, 375 bar)	Tubería producto (Ø 9,5 mm, 1 m de largo, 375 bar)	2
-	049 596 110	Canne d'aspiration inox Ø 25 avec crépine	Suction rod (stainless steel) Ø 25 with strainer	Saugschlauch, Edelstahl Ø 25 mit Siebkorb	Caña de aspiración de inox Ø 25 con piña	2
*	149 591 400	▪ Crépine avec manchon	▪ Strainer with sleeve	▪ Siebkorb	▪ Piña con manguito	1
-	155 581 400	Filtre AIRLESS® inox 3/4 (Doc. 573.327.050)	AIRLESS filter, model 3/4, stainless steel (Doc. 573.327.050)	AIRLESS® Filter 3/4, Edelstahl (Dok. 573.327.050)	Filtro AIRLESS® de inox, tipo 3/4 (Doc. 573.327.050)	2
-	049 596 000	Canne de purge inox	Drain rod, stainless steel	Entleerungsschlauch, Edelstahl	Caña de purga de inox	2
-	910 090 101	Eprouvette (2 litres)	Beaker (2 liters / 0.26 US gal)	Messzylinder (2 Liter)	Probeta (2 litros)	2
-	903 050 541	Electrovannes ATEX 24V	ATEX electrovalves, model 24V	Elektroventile, ATEX 24V	Electroválvulas ATEX 24V	2
-	903 050 529	Electrovannes ATEX	ATEX electrovalves	ATEX Elektroventile	Electroválvulas ATEX	3
-	901 180 024	Câble de mise à la terre (Lg. 5m) avec rondelle et vis	Cable ground (5 m / 197" length) with washer and screw	Erdungskabel (5 m) mit Scheibe und Schraube	Cable de puesta a tierra (5m de largo) con arandela y tornillo	1

ACCESSOIRES - ACCESSORIES - ZUBEHÖR - ACCESORIOS

Ind	#	Désignation	Description	Bezeichnung	Denominación	Qté
-	149 990 020	Flacon de lubrifiant T (125 ml)	T lubricant (125 ml / 4.4 oz)	Spülmittel « T » (125 ml)	Recipiente de lubricante T (125 ml)	1
-	149 990 021	Flacon de lubrifiant P (2 L)	P lubricant (2 l / 0.26 US gal)	Spülmittel « P » (2 Liter)	Recipiente de lubricante P (2 litros)	1
-	209 942	Clé pour cuve presse-garniture	Wrench for wetting-cup	Schlüssel für Spülmitteltasse	Llave para prensa-estopa	1

OPTION - ON REQUEST - OPTIONEN - OPCIÓN

PS
Ind. / Pos. 24



Ind. / Pos. 25

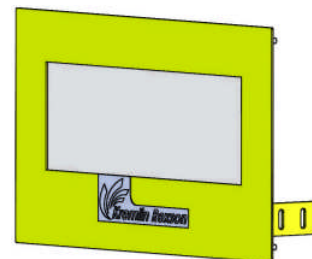

Ind	#	Désignation	Description	Bezeichnung	Denominación	Qté
24	151 145 090	Pompe de rinçage pour pompe PU 3000, modèle EOS 30-C25 (Doc. 573.438.050)	Flushing pump for PU 3000 pump, model EOS 30-C25 (Doc. 573.438.050)	Spülpumpe für 2-K-Anlage PU 3000, Modell EOS 30-C25 (Dok. 573.438.050)	Bomba de limpieza para bomba PU 3000, tipo EOS 30-C25 (Doc. 573.438.050)	1
25	155 660 340	Kit commande en cabine	Booth control kit	Set für Kabinensteuerung	Kit mando en cabina	1
-	149 990 020	Flacon de lubrifiant T (125 ml)	T lubricant (125 ml / 4.4 oz)	Spülmittel « T » (125 ml)	Recipiente de lubricante T (125 ml)	1
-	149 990 021	Flacon de lubrifiant P (2 L)	P lubricant (2 l / 0.26 US gal)	Spülmittel « P » (2 Liter)	Recipiente de lubricante P (2 litros)	1

* Pièces de maintenance préconisées.

* Preceding the index number denotes a suggested spare part.

* Bezeichnete Teile sind empfohlene Ersatzteile.

* Piezas de mantenimiento preventivas.

N C : Non commercialisé.

N S : Denotes parts are not serviceable.

N S : Bezeichnete Teile gibt es nicht einzeln, sondern nur komplett.

N S : no suministrado.

<p>Doc. 573.450.050 Date/Datum/Fecha : 10/02/14 Annule/Cancela/ Ersetzt/Anula :</p>	<p>Modif. / Änderung :</p>	<p>Pièces de rechange Spare parts list Ersatzteilliste Piezas de repuesto</p>
---	-----------------------------------	--

PU 3000 : MOTEUR A AIR / AIR MOTOR / LUFTMOTOR / MOTOR DE AIRE
Mod. 7000 # 155.680.129

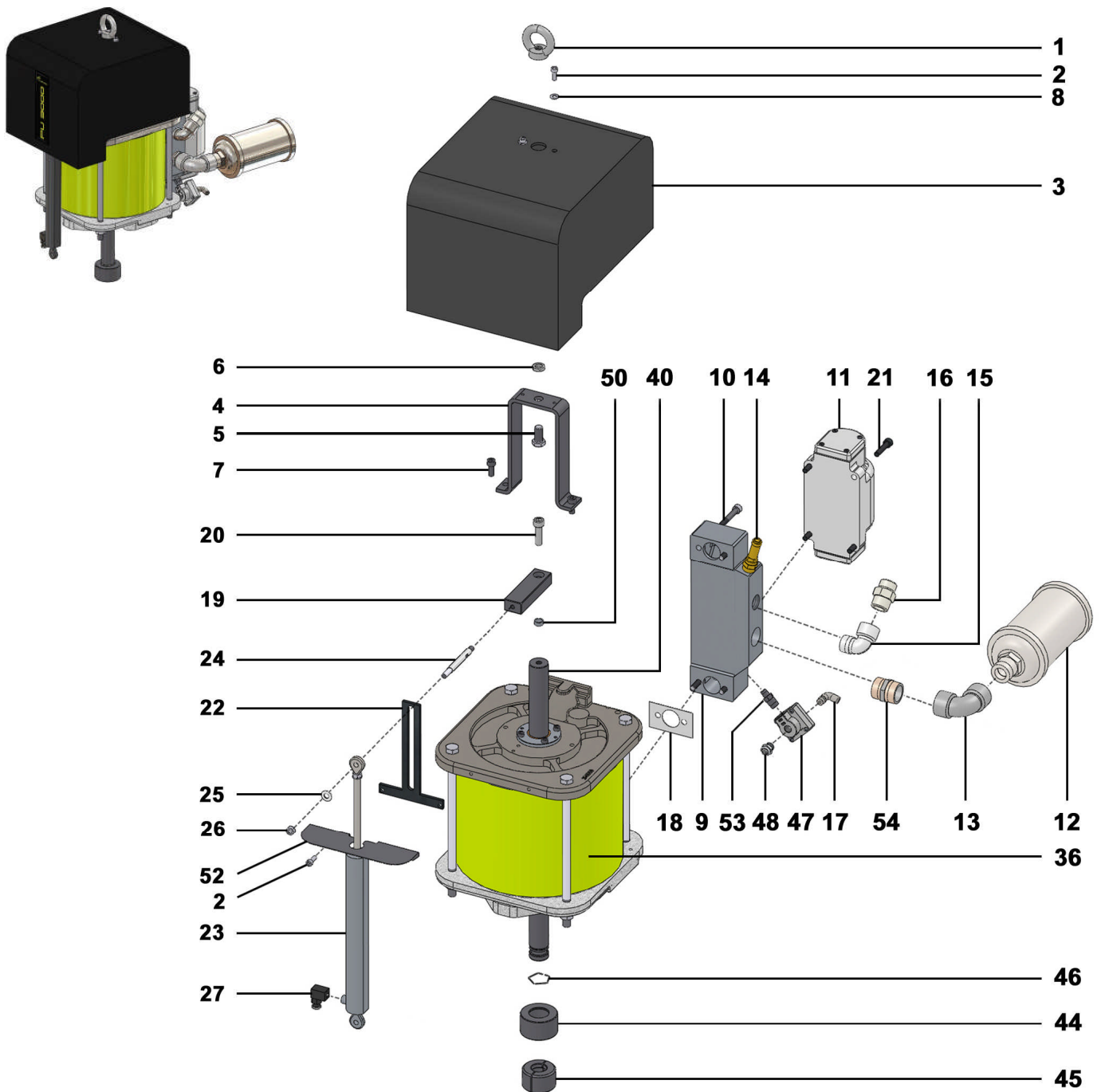

Détails - Details - Einzelheiten - Detalles

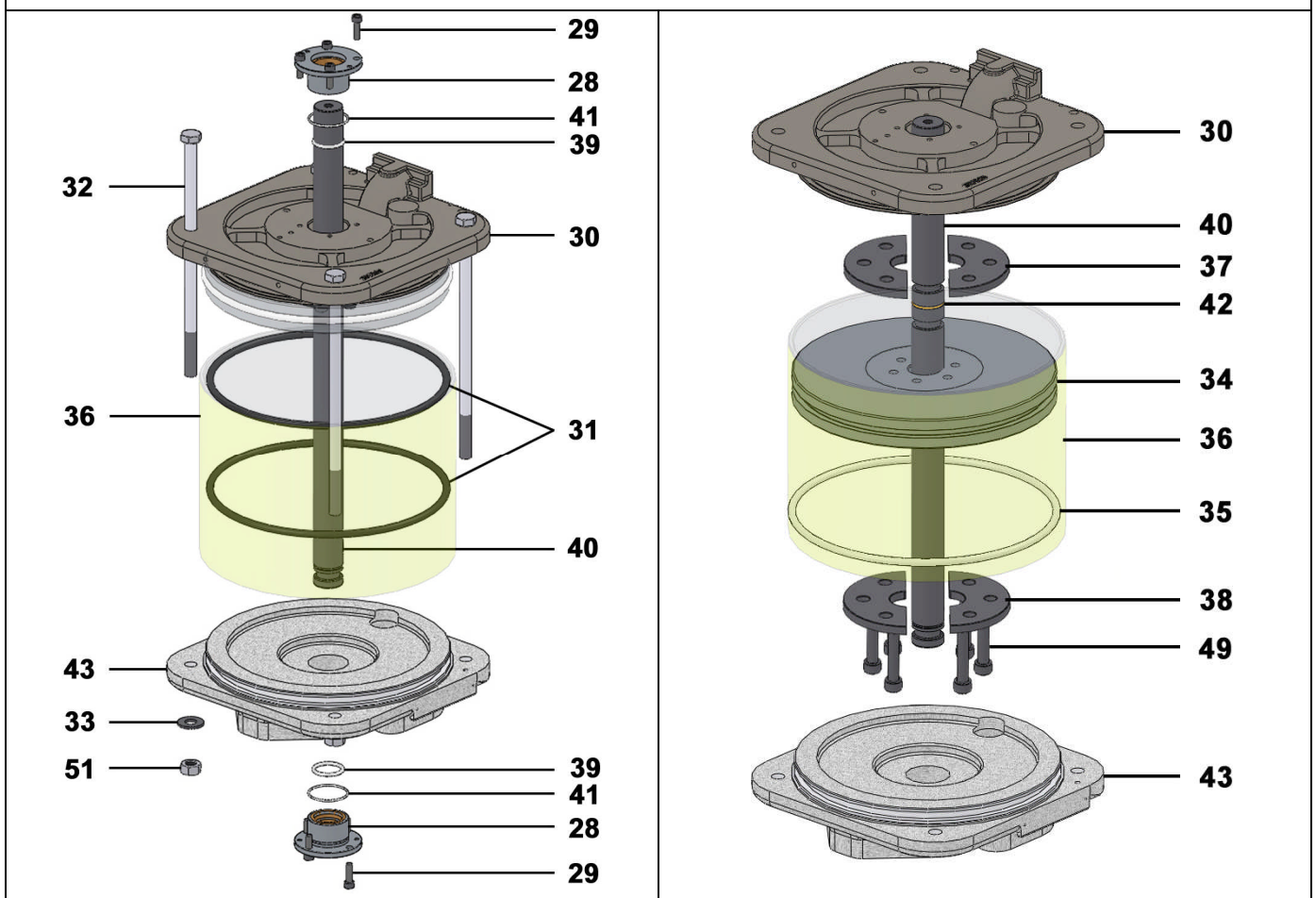

Ind	#	Désignation	Description	Bezeichnung	Denominación	Qté
1	91 422	Anneau de levage	Hoisting ring	Ringsschraube	Anillo de sujeción	1
2	933 151 196	Vis CHc M 6 x 16	Screw, model CHc M 6 x 16	Schraube, CHc M 6 x 16	Tornillo, tipo CHc M 6 x 16	4
3	NC / NS	Capot	Cover	Haube	Capó	1
4	209 359	Etrier	U-Bolt	Halterung	Tirante	1
5	88 069	Vis HM 12 x 25	Screw, model HM 12 x 25	Schraube, HM 12 x 25	Tornillo, tipo HM 12 x 25	1
6	88 321	Ecrou HM 12	Nut, model HM 12	Mutter, HM 12	Tuerca, tipo HM 12	1
7	88 151	Vis CHc M 8 x 20	Screw, model CHc M 8 x 20	Schraube, CHc M 8 x 20	Tornillo, tipo CHc M 8 x 20	2
8	963 040 016	Rondelle MU 6	Washer, model MU 6	Scheibe, MU 6	Arandela, tipo MU 6	2
9	209 357	Embase distributeur	Distributor base	Grundplatte Pneum.Ventil	Base distribuidor	1
10	933 151 601	Vis CHc M 8 x 60	Screw, model CHc M 8 x 60	Schraube, CHc M 8 x 60	Tornillo, tipo CHc M 8 x 60	4
*11	146 320 092	Distributeur 4/2	Distributor, model 4/2	4/2 Wege Pneum. Ventil	Distribuidor, tipo 4/2	1
*12	146 320 091	Silencieux 1"	Muffler, model 1"	Schalldämpfer, 1"	Silenciador, tipo 1"	1
*13	552 598	Coude FF 1" BSP	Elbow, model FF 1" BSP	Winkelnippel, IG/IG1" BSP	Codo, tipo HH 1" BSP	1
14	903 080 401	Soupape de sécurité	Safety valve	Sicherheitsventil	Válvula de seguridad	1
15	552 434	Coude MF 3/4"	Elbow, model MF 3/4"	Winkelnippel, AG/IG 3/4"	Codo, tipo MH 3/4"	1

Ind	#	Désignation	Description	Bezeichnung	Denominación	Qté
16	050 102 634	Raccord M 3/4" NPS - M 3/4" G	Racor, model double male, 3/4" NPS - 3/4" G	Anschluss, AG 3/4" NPS - AG 3/4" G	Racor, tipo M 3/4" NPS - M 3/4" G	1
17	905 120 927	Raccord coudé M 1/4" G - T 2,7 x 4	Elbow fitting, double male, 1/4" G - T 2,7 x 4	Winkelnippel AG 1/4" G - 2,7 x 4	Racor acodado, tipo M 1/4" G - T 2,7 x 4	1
18	NC / NS	Joint d'embase	Base seal	Grundplattendichtung	Junta de base	2
19	NC / NS	Entraînement capteur	Sensor driving	Potentiometer Mitnehmer	Arrastre captador	1
20	930 151 448	Vis CHc M 10 x 35	Screw, model CHc M 10 x 35	Schraube, CHc M 10 x 35	Tornillo, tipo CHc M 10 x 35	1
21	NC / NS	Vis CHc M 8 x 35	Screw, model CHc M 8 x 35	Schraube, CHc M 8 x 35	Tornillo, tipo CHc M 8 x 35	4
22	055 680 064	Guide pour capteur	Guide for sensor	Potentiometer Führung	Guía para captador	1
23	91 519	Capteur de déplacement	Movement sensor	Linearpotentiometer	Captador de movimiento	1
24	055 680 004	Témoin de course	Stroke detector	Hubanzeiger	Téstigo de recorrido	1
25	963 040 019	Rondelle MU 8	Washer, model MU 8	Scheibe, MU 8	Arandela, tipo MU 8	1
26	953 010 019	Ecrou HM 8	Nut, model HM 8	Mutter, HM 8	Tuerca, tipo HM 8	1
27	91 517	Connecteur	Connector	Stecker	Conectador	1
28	146 320 095	Palier	Bearing	Lagerbuchse	Palier	2
29	88 134	Vis CHc M 6 x 20	Screw, model CHc M 6 x 20	Schraube, CHc M 6 x 20	Tornillo, tipo CHc M 6 x 20	8
30	209 360	Flasque supérieur	Upper flange	Oberer Flansch	Brida superior	1
31	NC / NS	Joint	Seal	Dichtung	Junta	2
32	NC / NS	Vis HM 12 x 260	Screw, model HM 12 x 260	Schraube, HM 12 x 260	Tornillo, tipo HM 12 x 260	4
33	963 040 023	Rondelle	Washer	Scheibe	Arandela	4
*34	209 363	Piston	Piston	Kolben	Pistón	1
35	NC / NS	Joint torique (piston)	O-Ring (piston)	O-Ring Dichtung (Kolben)	Junta tórica (pistón)	1
36	205 209	Cylindre	Cylinder	Zylinder	Cilindro	1
37	205 593	Contre bride	Adapter	Kupplungsschalen	Contra brida	1
38	205 592	Bride d'arrêt	Stop flange	Stoppscheibe	Brida de parada	1
39	NC / NS	Joint	Seal	Dichtung	Junta	2
40	205 591	Tige de piston	Piston rod	Kolbenstange	Eje de pistón	1
41	NC / NS	Joint	Seal	Dichtung	Junta	2
42	NC / NS	Joint	Seal	Dichtung	Junta	1
43	209 361	Flasque inférieur	Lower flange	Bodenflansch	Brida inferior	1
44	205 212	Bague de fermeture	Closing ring	Hülse	Anillo de cierre	1
45	205 211	Coquille	Bush	Kupplung	Coquilla	1
46	90 165	Frein d'axe	Axis-lock	Sicherungsring	Freno de eje	1
47	903 050 538	Vanne d'échappement	Escape valve	Entlüftungsventil	Válvula de escape	1
48	90 018	Silencieux 1/4"	Muffler, model 1/4"	Schalldämpfer 1/4"	Silenciador, tipo 1/4"	1
49	88 735	Vis CHc M 8 x 45	Screw, model CHc M 8 x 45	Schraube, CHc M 8 x 45	Tornillo, tipo CHc M 8 x 45	6
50	NC / NS	Entretoise	Spacer	Distanzstück	Tirante	1
51	953 010 023	Ecrou HM 12	Nut, model HM 12	Mutter, HM 12	Tuerca, tipo HM 12	4

Ind	#	Désignation	Description	Bezeichnung	Denominación	Qté
52	NC / NS	Plaque complément de capot	Cover plate complement	Führungsplatte für Haube	Placa complemento de capó	1
53	904 523 001	Raccord M 1/4" G - M 1/8" G	Racor, model double male, 1/4" G - 1/8" G	Anschluss, AG 1/4" G - AG 1/8" G	Racor, tipo M 1/4" G - M 1/8" G	1
54	552 466	Adaptateur MM 1" G	Adaptor, model double male 1" G	Anschluss AG 1" G	Adaptador, tipo MM 1" G	1

Ind	#	Désignation	Description	Bezeichnung	Denominación	Qté
*	146 330 090	Pochette de joints moteur (Ind. 18x2, 31x2, 35, 39x2, 41x2, 42)	Seal kit air motor (Ind. 18x2, 31x2, 35, 39x2, 41x2, 42)	Dichtungssatz für Luftmotor (Pos. 18x2, 31x2, 35, 39x2, 41x2, 42)	Bolsa de juntas motor (Índ. 18x2, 31x2, 35, 39x2, 41x2, 42)	1

* Pièces de maintenance préconisées.

* Preceding the index number denotes a suggested spare part.

* Bezeichnete Teile sind empfohlene Ersatzteile.

* Piezas de mantenimiento preventivas.

N C : Non commercialisé.

N S : Denotes parts are not serviceable.

N S : Bezeichnete Teile gibt es nicht einzeln, sondern nur komplett.

N S : no suministrado.



Doc. 573.447.050 Date/Datum/Fecha : 18/09/15 Annule/Cancel/ Ersetzt/Anula : 20/06/14	Modif. / Änderung : # 106 284 (+ Ind. / Pos. 9, 11c) + # 106 285 supprimé / canceled / annulliert / suprimido	Pièces de rechange Spare parts list Ersatzteilliste Piezas de repuesto
--	---	---

HYDRAULIQUE A BILLE, modèle MAJOR 227CC	BALL FLUID SECTION, model MAJOR 227CC
KUGEL HYDRAULIKTEIL, Modell MAJOR 227CC	HIDRÁULICA CON BOLA, tipo MAJOR 227CC



HYDRAULIQUE A BILLE, modèle MAJOR 227CC	BALL FLUID SECTION, model MAJOR 227CC	#
KUGEL HYDRAULIKTEIL, Modell MAJOR 227CC	HIDRÁULICA CON BOLA, tipo MAJOR 227CC	105.174.01.xx

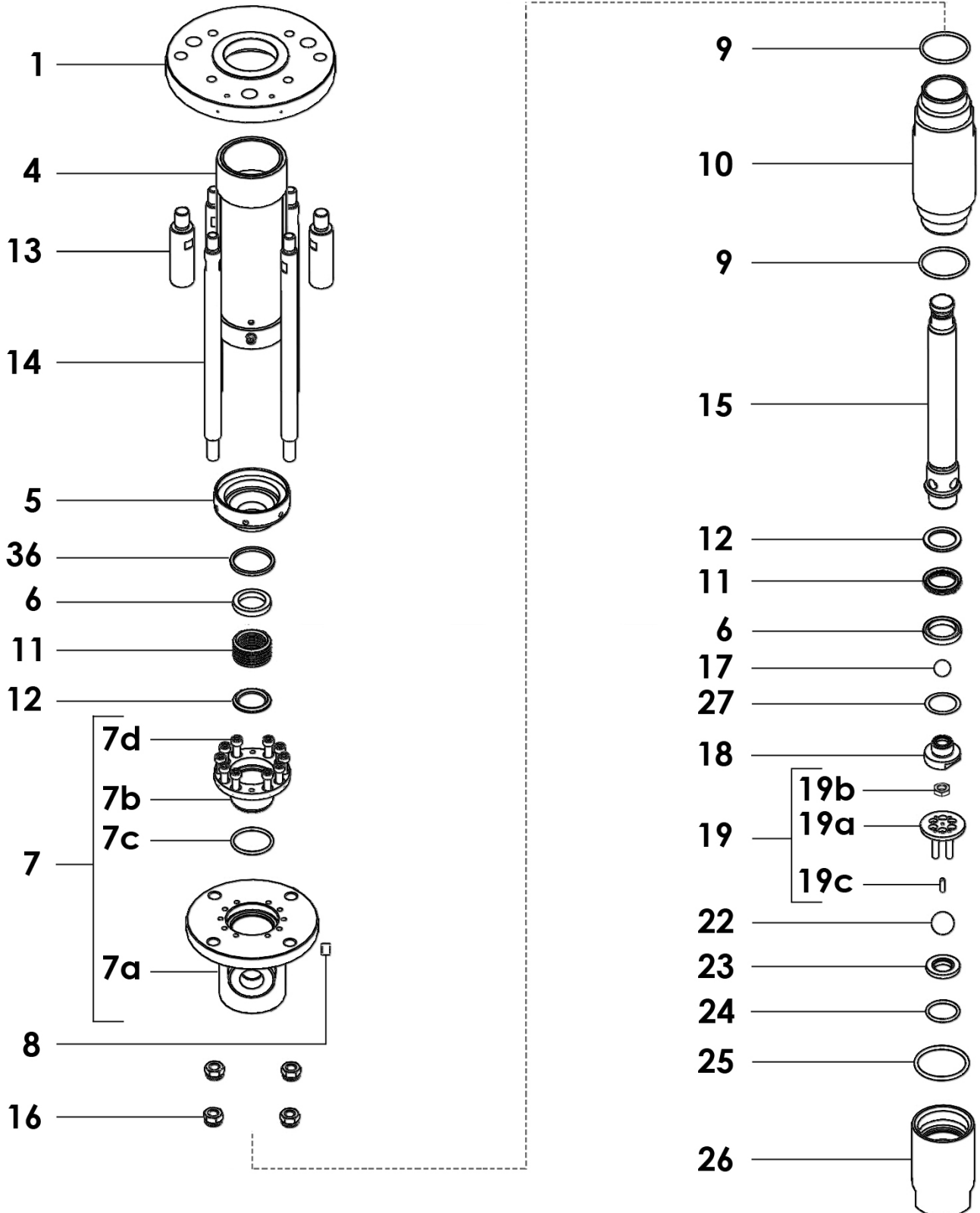

Ind	#	Désignation	Description	Bezeichnung	Denominación	Qté
1	210 620	Bride de liaison	Connecting flange	Verbindungsflansch	Brida de unión	1
4	044 230 010	Carter de protection	Protection housing	Schützgehäuse	Cárter de protección	1
5	044 240 140	Ecrou de presse-étoupe	Cup nut	Packungsmutter	Tuerca de prensa-estopa	1
6	209 651	Presse-joint "F" (inox)	'F' washer (stainless steel)	Stützring konkav (aus Edelstahl)	Prensa junta "H" (inox)	2
7	210 624	Corps de pompe	Pump body	Pumpenkörper	Cuerpo de bomba	1
7a	NC / NS	▪ Corps	▪ body	▪Körper	▪Cuerpo	1
7b	NC / NS	▪ Cartouche	▪ Cartridge	▪Packung	▪Cartucho	1
7c	NC / NS	▪ Joint	▪ Seal	▪Dichtung	▪Junta	1
7d	930 151 279	▪ Vis CHc M 8x20	▪ Screw, model CHc M 8x20	▪ Schraube, Modell CHc M 8x20	▪ Tornillo, tipo CHc M 8x20	10
8	906 333 102	Bouchon	Plug	Blindstopfen	Tapón	1
10	210 627	Cylindre	Cylinder	Zylinder	Cilindro	1
12	209 652	Presse-joint "M" (inox)	'M' washer (stainless steel)	Stützring konvex (aus Edelstahl)	Prensa-junta "M" (inox)	2
13	209 582	Pivot	Pin	Bolzen	Pivote	2
14	210 621	Tirant	Tie-rod	Verbindungsstange	Tirante	4
*15	210 626	Tige de piston	Piston rod	Kolbenstange	Eje de piston	1
16	88 339	Ecrou frein	Lock nut	Blockiermutter	Tuerca freno	4
*17	87 320	Bille Ø 20 (inox)	Ball, model Ø 20 (stainless steel)	Kugel, Modell Ø 20 (aus Edelstahl)	Bola, tipo Ø 20 (inox)	1
*18	209 649	Siège de piston supérieur	Upper piston seat	Oberer Kolbensitz	Asiento de pistón superior	1
19	107 307	Cage de bille équipée	Ball cage fitted	Kugelkäfig kplt.	Jaula de bola equipada	1
19a	NC / NS	▪ Cage de bille	▪ Ball cage	▪ Kugelkäfig	▪ Jaula de bola	1
19b	NC / NS	▪ Contre-écrou	▪ Lock nut	▪ Gegenmutter	▪ Contra-tuerca	1
19c	NC / NS	▪ Vis	▪ Screw	▪ Schraube	▪ Tornillo	1
*22	87 328	Bille Ø 28 (inox)	Ball, model Ø 28 (stainless steel)	Kugel, Modell Ø 28 (aus Edelstahl)	Bola, tipo Ø 28 (inox)	1
*23	209 612	Siège inférieur (inox)	Lower seat (stainless steel)	Unterer Sitz (aus Edelstahl)	Asiento inferior (inox)	1
26	210 619	Corps de clapet de pied	Foot valve body	Basisventilkörper	Cuerpo de válvula de pie	1
31	044 950 008	Clé de presse-étoupe	Cup wrench	Packungsmutter - schlüssel	Llave de prensa-estopa	1
-	149 990 020	Flacon de lubrifiant T (125 ml)	T Lubricant (125 ml / 4.4 oz)	Lösemittel "T" (125 ml)	Recipiente de lubricante T (125 ml)	1

Ind. 31



* Pièces de maintenance préconisées.

* Preceding the index number denotes a suggested spare part.

* Bezeichnete Teile sind empfohlene Ersatzteile.

* Piezas de mantenimiento preventivas.

NC : Non commercialisé.

NS : Denotes parts are not serviceable.

NS : Bezeichnete Teile gibt es nicht einzeln, sondern nur komplett .

NS : no suministrado.

■ **PRECONISATION DES POCHETTES DE JOINTS**

Code	Composition	Utilisation
01	PTFE (+ FPM)	Solvant - Ether - Cétone - Alcool aromatique - certains vernis et peintures
02	PTFE (+ FPM / FEP)	Solvant - Ether - Cétone - Alcool aromatique - certains vernis et peintures, peintures PU - Pharmacie - Cosmétique - Certains produits alimentaires
03	PTFE + PE (+ FPM)	Colle époxy - Butyl - Silicone - Certains vernis - Peinture
04	PE + CUIR (+ FPM)	Peinture - Vernis - Graisse - Huile - Encre - Peinture hydrosoluble
05	PTFE GRAPHITÉ (+ FPM)	Peinture - Vernis - Encres - Mastics PVC - Butyl
06	PU + PTFE GRAPHITE (+ FPM)	Mastics - PVC - Butyl
07	PE + PTFE GRAPHITE (+ FPM)	Peinture - Vernis - Graisse - Huile - Encres - Peinture hydrosoluble - Mastics - PVC - Butyl

■ **SEAL KIT RECOMMENDED**

Code	Composition	Use
01	PTFE (+ FPM)	Solvent - Ether - Ketone - Aromatic alcohol - some varnishes and paints
02	PTFE (+ FPM / FEP)	Solvent - Ether - Ketone - Aromatic alcohol - some varnishes and paints, PU paints - Pharmacy - Cosmetics - Some foodstuffs
03	PTFE + PE (+ FPM)	Epoxy glue - Butyl - PVC compound - Silicone - Some varnishes - Paint
04	PE + LEATHER (+ FPM)	Paint - Varnishes - Grease - Oil - Ink - Hydro soluble paint
05	GRAPHITED PTFE (+ FPM)	Paints - Varnishes - Inks - PVC compounds - Butyl
06	PU + GRAPHITED PTFE (+ FPM)	Mastics - PVC - Butyl
07	PE + GRAPHITED PTFE (+ FPM)	Paint - Varnishes - Grease - Oil - Inks - Hydro soluble paint - Mastics - PVC - Butyl

■ **EMPFOHLENE DICHTUNGSWERKSTOFFE**

Variante	Zusammensetzung	Benutzung
01	PTFE (+ FPM)	Lösemittel - Äther - Ketone - aromatisierter Alkohol - einige Ölfarben - Lacke
02	PTFE (+ FPM / FEP)	Lösemittel - Äther - Keton - aromatisierter Alkohol - einige Ölfarben - Lacke - PU Lacke - Pharmazeutische Produkte - kosmetische Produkte - Einige Nahrungsmittel
03	PTFE + PE (+ FPM)	Epoxy Kleber - Butyl - Silikon - Einige Ölfarben -Lacke
04	PE + LEDER (+ FPM)	Lacke - Ölfarben - Fett - Öl - Tinte - Druckereifarben - Wasserbasis Farben
05	PTFE GRAPHIT (+ FPM)	Lacke - Ölfarben - Tinte - Dichtstoffe - PVC - Butyl - Druckereifarben
06	PU + PTFE GRAPHIT (+ FPM)	Dichtstoffe - PVC - Butyl
07	PE + PTFE GRAPHIT (+ FPM)	Lacke - Ölfarben - Fett - Öl - Tinte - Druckereifarben - Wasserbasis Farben - Dichtstoffe - PVC - Butyl

■ **PRECONIZACIÓN DE LAS BOLSAS DE JUNTAS**

Código	Composición	Utilización
01	PTFE (+ FPM)	Disolvente - Éter - Cetona - Alcohol aromático - ciertos barnices y pinturas
02	PTFE (+ FPM / FEP)	Disolvente - Éter - Cetona - Alcohol aromático - ciertos barnices y pinturas, pinturas PU- Farmacia - Cosmético - Ciertos productos alimentarios
03	PTFE + PE (+ FPM)	Cola epoxi - Butil - Silicona - Ciertos barnices - Pintura
04	PE + CUERO (+ FPM)	Pintura - Barnices - Grasa - Aceite - Tinta - Pintura hidrosoluble
05	PTFE GRAFITADO (+ FPM)	Pinturas - Barnices - Tintas - Masillas PVC - Butil
06	PU + PTFE GRAFITADO (+ FPM)	Masillas - PVC - Butil
07	PE + PTFE GRAFITADO (+ FPM)	Pintura - Barnices - Grasa - Aceite - Tintas - Pintura hidrosoluble - Masillas - PVC - Butil

POCHETTE DE JOINTS / PACKAGE OF SEALS / DICHTUNGSSATZ / BOLSA DE JUNTAS (ind.11)

■ **HYDRAULIQUE / FLUID SECTION / HIDRAULIKTEIL / HIDRÁULICA # 105 174 01 01**

Ind	#	Désignation	Description	Bezeichnung	Denominación	Qté
*	106 281	Pochette de joints	Seal kit	Dichtungssatz	Bolsa de juntas	1
7c	909 420 271	▪ Joint de cartouche FPM	▪ FPM cartridge seal	▪ FPM-Packungsring	▪ Junta de cartucho FPM	1
9	84 468	▪ Joint torique FPM	▪ FPM O-Ring	▪ FPM-O-Ring Dichtung	▪ Junta tórica FPM	3
11a	209 655	▪ Joint de chevron PTFE	▪ PTFE chevron seal	▪ PTFE-Packungsring	▪ Junta de chevrón PTFE	15
24	84 390	▪ Joint torique PTFE	▪ PTFE O-Ring	▪ PTFE-O-Ring Dichtung	▪ Junta tórica PTFE	1
25	84 188	▪ Joint torique FPM	▪ FPM O-Ring	▪ FPM-O-Ring Dichtung	▪ Junta tórica FPM	1
-	84 391	▪ Joint torique PTFE	▪ PTFE O-Ring	▪ PTFE-O-Ring Dichtung	▪ Junta tórica PTFE	1
-	909 130 540	▪ Joint torique FPM	▪ FPM O-Ring	▪ FPM-O-Ring Dichtung	▪ Junta tórica FPM	1

Montage des joints / Assembly seals / Montage der Dichtungen / Montaje de las juntas :

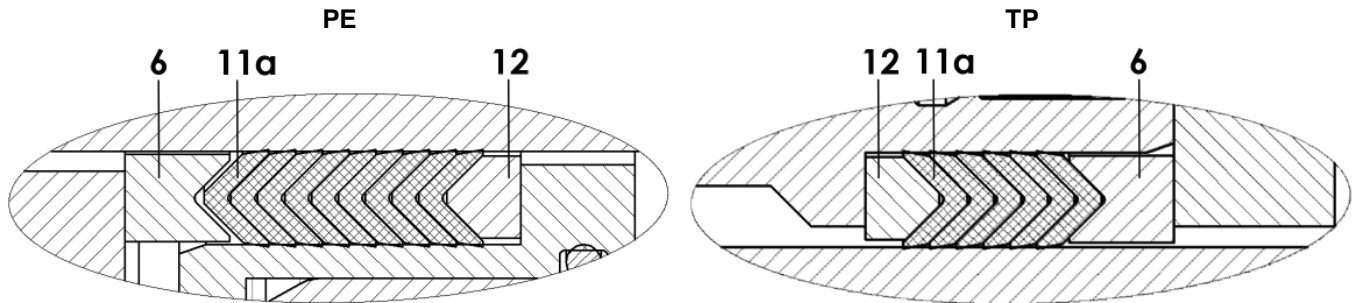

■ **HYDRAULIQUE / FLUID SECTION / HIDRAULIKTEIL / HIDRÁULICA # 105 174 01 02**

Ind	#	Désignation	Description	Bezeichnung	Denominación	Qté
*	106 282	Pochette de joints	Seal kit	Dichtungssatz	Bolsa de juntas	1
7c	909 420 271	▪ Joint de cartouche FPM	▪ FPM cartridge seal	▪ FPM-Packungsring	▪ Junta de cartucho FPM	1
9	84 471	▪ Joint torique FPM / FEP	▪ FPM / FEP O-Ring	▪ FPM / FEP-O-Ring Dichtung	▪ Junta tórica FPM / FEP	3
11a	209 655	▪ Joint de chevron PTFE	▪ PTFE chevron seal	▪ PTFE-Packungsring	▪ Junta de chevrón PTFE	15
24	84 390	▪ Joint torique PTFE	▪ PTFE O-Ring	▪ PTFE-O-Ring Dichtung	▪ Junta tórica PTFE	1
25	84 188	▪ Joint torique FPM	▪ FPM O-Ring	▪ FPM-O-Ring Dichtung	▪ Junta tórica FPM	1
-	84 391	▪ Joint torique PTFE	▪ PTFE O-Ring	▪ PTFE-O-Ring Dichtung	▪ Junta tórica PTFE	1
-	909 130 540	▪ Joint torique FPM	▪ FPM O-Ring	▪ FPM-O-Ring Dichtung	▪ Junta tórica FPM	1

Montage des joints / Assembly seals / Montage der Dichtungen / Montaje de las juntas :

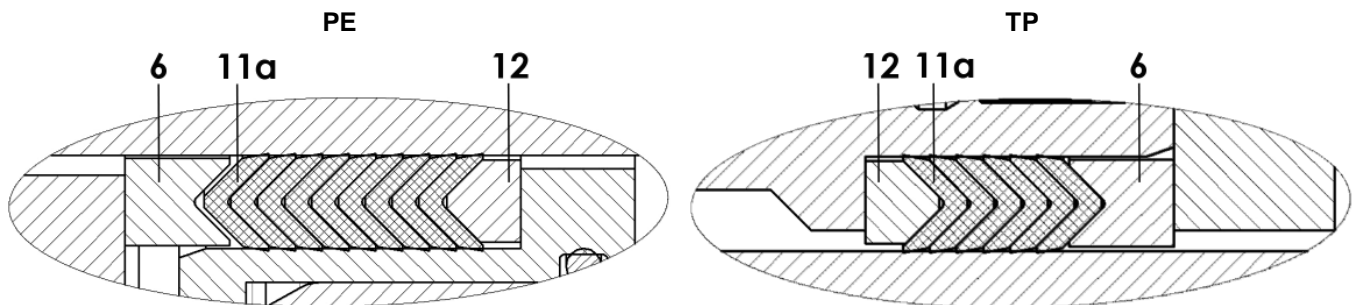

■ HYDRAULIQUE / FLUID SECTION / HIDRAULIKTEIL / HIDRÁULICA # 105 174 01 03

Ind	#	Désignation	Description	Bezeichnung	Denominación	Qté
*	106 283	Pochette de joints	Seal kit	Dichtungssatz	Bolsa de juntas	1
7c	909 420 271	▪ Joint de cartouche FPM	▪ FPM cartridge seal	▪ FPM-Packungsring	▪ Junta de cartucho FPM	1
9	84 468	▪ Joint torique FPM	▪ FPM O-Ring	▪ FPM-O-Ring Dichtung	▪ Junta tórica FPM	3
11a	209 655	▪ Joint de chevron PTFE	▪ PTFE chevron seal	▪ PTFE-Packungsring	▪ Junta de chevrón PTFE	7
11b	209 656	▪ Joint de chevron PE	▪ PE chevron seal	▪ PE-Packungsring	▪ Junta de chevrón PE	8
24	84 390	▪ Joint torique PTFE	▪ PTFE O-Ring	▪ PTFE-O-Ring Dichtung	▪ Junta tórica PTFE	1
25	84 188	▪ Joint torique FPM	▪ FPM O-Ring	▪ FPM-O-Ring Dichtung	▪ Junta tórica FPM	1
-	84 391	▪ Joint torique PTFE	▪ PTFE O-Ring	▪ PTFE-O-Ring Dichtung	▪ Junta tórica PTFE	1
-	909 130 540	▪ Joint torique FPM	▪ FPM O-Ring	▪ FPM-O-Ring Dichtung	▪ Junta tórica FPM	1

Montage des joints / Assembly seals / Montage der Dichtungen / Montaje de las juntas :

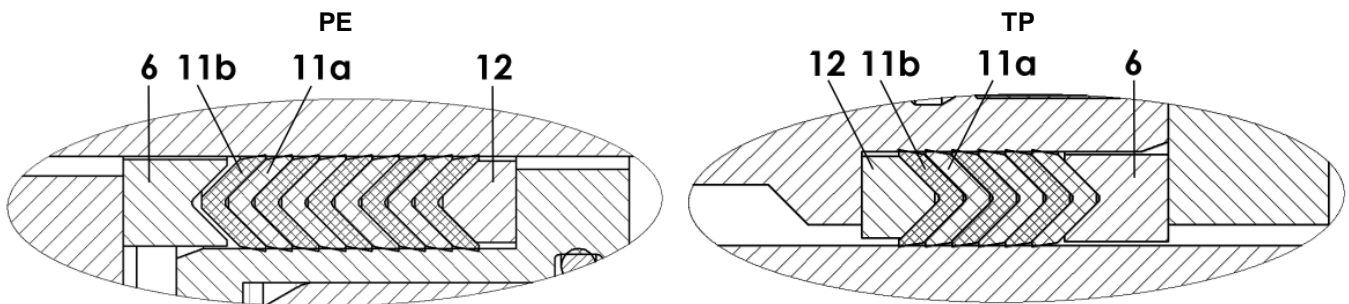

■ HYDRAULIQUE / FLUID SECTION / HIDRAULIKTEIL / HIDRÁULICA # 105 174 01 04

Ind	#	Désignation	Description	Bezeichnung	Denominación	Qté
*	106 284	Pochette de joints	Seal kit	Dichtungssatz	Bolsa de juntas	1
7c	909 420 271	▪ Joint de cartouche FPM	▪ FPM cartridge seal	▪ FPM-Packungsring	▪ Junta de cartucho FPM	1
9	84 468	▪ Joint torique FPM	▪ FPM O-Ring	▪ FPM-O-Ring Dichtung	▪ Junta tórica FPM	2
11b	209 656	▪ Joint de chevron PE	▪ PE chevron seal	▪ PE-Packungsring	▪ Junta de chevrón PE	7
11c	209 657	▪ Joint de chevron Cuir	▪ Leather chevron seal	▪ Leder-Packungsring	▪ Junta de chevrón cuero	7*
24	84 390	▪ Joint torique PTFE	▪ PTFE O-Ring	▪ PTFE-O-Ring Dichtung	▪ Junta tórica PTFE	1
25	84 188	▪ Joint torique FPM	▪ FPM O-Ring	▪ FPM-O-Ring Dichtung	▪ Junta tórica FPM	1
27	210 341	▪ Cale de réglage inox	▪ Stainless steel adjustment block	▪ Edelstahl Scheiben für Höhenpassung	▪ Cuña de ajuste inox	4*
-	84 391	▪ Joint torique PTFE	▪ PTFE O-Ring	▪ PTFE-O-Ring Dichtung	▪ Junta tórica PTFE	1
-	909 130 540	▪ Joint torique FPM	▪ FPM O-Ring	▪ FPM-O-Ring Dichtung	▪ Junta tórica FPM	1

* Quantité à monter suivant besoin / Quantity mounted according to need / Stückzahl je nach Bedarf / Cantidad montada según necesidad

Montage des joints / Assembly seals / Montage der Dichtungen / Montaje de las juntas :

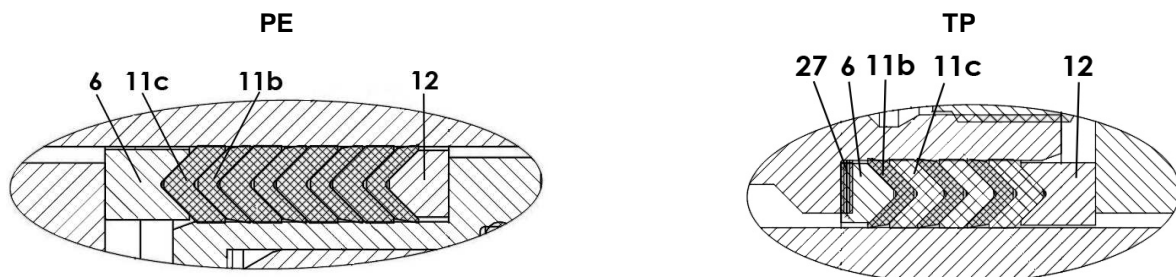

■ HYDRAULIQUE / FLUID SECTION / HIDRAULIKTEIL / HIDRÁULICA # 105 174 01 06

Ind	#	Désignation	Description	Bezeichnung	Denominación	Qté
*	106 286	Pochette de joints	Seal kit	Dichtungssatz	Bolsa de juntas	1
7c	909 420 271	▪ Joint de cartouche FPM	▪ FPM cartridge seal	▪ FPM-Packungsring	▪ Junta de cartucho FPM	1
9	84 468	▪ Joint torique FPM	▪ FPM O-Ring	▪ FPM-O-Ring Dichtung	▪ Junta tórica FPM	3
11b	209 656	▪ Joint de chevron PE	▪ PE chevron seal	▪ PE-Packungsring	▪ Junta de chevrón PE	1
11d	209 658	▪ Joint de chevron PTFE G	▪ PTFE G chevron seal	▪ PTFE G-Packungsring	▪ Junta de chevrón PTFE G	6
11e	84 411	▪ Joint de chevron PU	▪ PU chevron seal	▪ PU-Packungsring	▪ Junta de chevrón PU	4
24	84 390	▪ Joint torique PTFE	▪ PTFE O-Ring	▪ PTFE-O-Ring Dichtung	▪ Junta tórica PTFE	1
25	84 188	▪ Joint torique FPM	▪ FPM O-Ring	▪ FPM-O-Ring Dichtung	▪ Junta tórica FPM	1
-	84 391	▪ Joint torique PTFE	▪ PTFE O-Ring	▪ PTFE-O-Ring Dichtung	▪ Junta tórica PTFE	1
-	909 130 540	▪ Joint torique FPM	▪ FPM O-Ring	▪ FPM-O-Ring Dichtung	▪ Junta tórica FPM	1
36	209 659	▪ Bague inox	▪ Stainless steel ring	▪ Edelstahl Ring	▪ Anillo inox	1

Montage des joints / Assembly seals / Montage der Dichtungen / Montaje de las juntas :

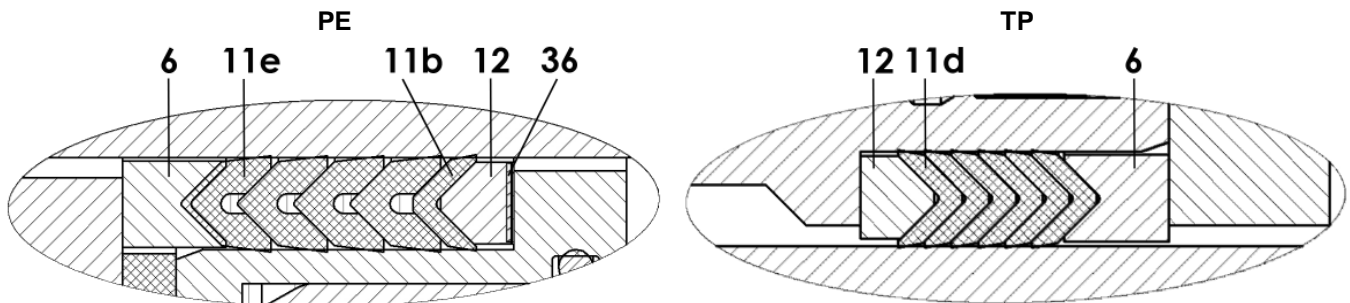

■ HYDRAULIQUE / FLUID SECTION / HIDRAULIKTEIL / HIDRÁULICA # 105 174 01 07

Ind	#	Désignation	Description	Bezeichnung	Denominación	Qté
*	107 367	Pochette de joints	Seal kit	Dichtungssatz	Bolsa de juntas	1
7c	909 420 271	▪ Joint de cartouche FPM	▪ FPM cartridge seal	▪ FPM-Packungsring	▪ Junta de cartucho FPM	1
9	84 468	▪ Joint torique FPM	▪ FPM O-Ring	▪ FPM-O-Ring Dichtung	▪ Junta tórica FPM	3
11b	209 656	▪ Joint de chevron PE	▪ PE chevron seal	▪ PE-Packungsring	▪ Junta de chevrón PE	8
11d	209 658	▪ Joint de chevron PTFE G	▪ PTFE G chevron seal	▪ PTFE G-Packungsring	▪ Junta de chevrón PTFE G	7
24	84 390	▪ Joint torique PTFE	▪ PTFE O-Ring	▪ PTFE-O-Ring Dichtung	▪ Junta tórica PTFE	1
25	84 188	▪ Joint torique FPM	▪ FPM O-Ring	▪ FPM-O-Ring Dichtung	▪ Junta tórica FPM	1
27	210 341	▪ Cale de réglage inox	▪ Stainless steel adjustment block	▪ Edelstahl Scheiben für Höhenpassung	▪ Cuña de ajuste inox	4
-	84 391	▪ Joint torique PTFE	▪ PTFE O-Ring	▪ PTFE-O-Ring Dichtung	▪ Junta tórica PTFE	1
-	909 130 540	▪ Joint torique FPM	▪ FPM O-Ring	▪ FPM-O-Ring Dichtung	▪ Junta tórica FPM	1

Montage des joints / Assembly seals / Montage der Dichtungen / Montaje de las juntas :

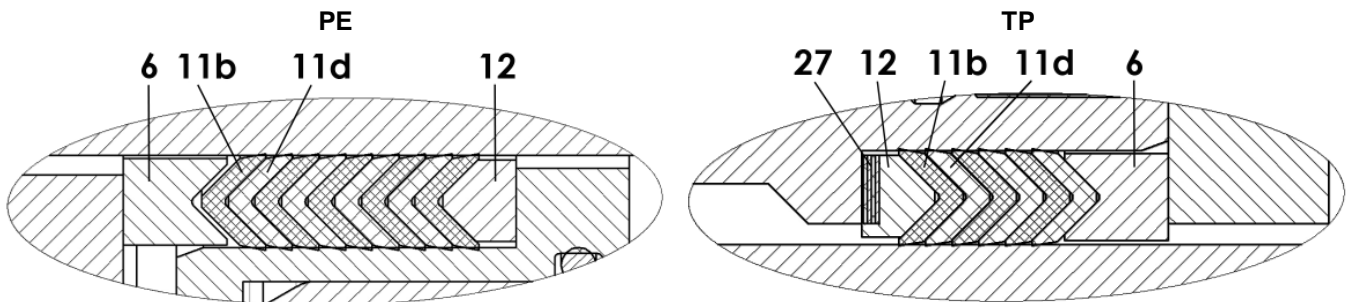



PTFE G = PTFE graphité / Graphited PTFE / PTFE Graphit / PTFE grafitado.

Doc. 573.062.050 Date/Datum/Fecha : 20/08/12 Annule/Cancel/Ersetzt/Anula : 18/10/11	Modif. / Änderung : Mise à jour / Update / Aktualisierung / Actualización	Pièces de rechange Spare parts list Ersatzteilliste Piezas de repuesto
---	--	---

ASI 24 - ASI 40 - ASI 40 GT - ASI 40 GT V

PISTOLET AUTOMATIQUE AIRLESS® INOX (SANS BUSE)
AIRLESS AUTOMATIC SPRAY GUN (WITHOUT TIP) - STAINLESS STEEL
AIRLESS® AUTOMATIK-PISTOLE IN EDELSTAHL (OHNE DÜSE)
PISTOLA AUTOMÁTICA AIRLESS® INOX (SIN BOQUILLA)

ASI 24 # 129.980.000	ASI 40	# 129.980.500	 2 & 3
ASI 40 GT # 129.980.600	ASI 40 GT V	# 129.980.650	 4 - 6
Tableau des buses / Tip chart / Düsentabelle / Cuadro de las boquillas			 6 & 7

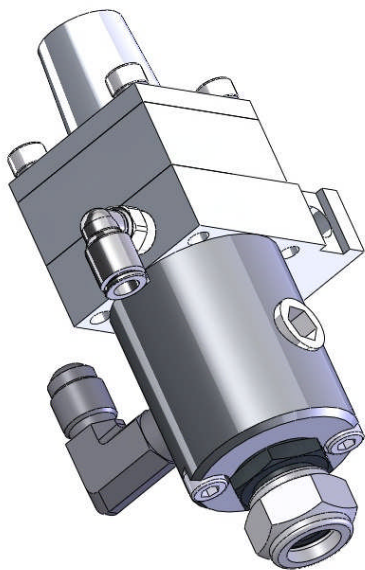

ASI 24 - ASI 40 - ASI 40 GT

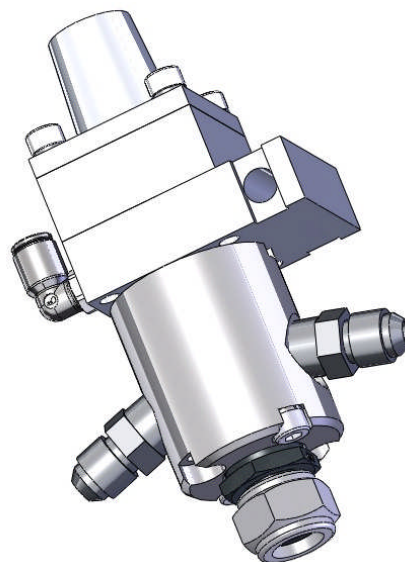

ASI 40 GT V

ASI 24 # 129.980.000

ASI 40 # 129.980.500

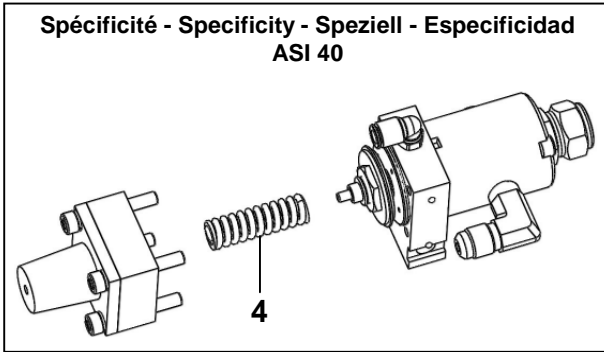
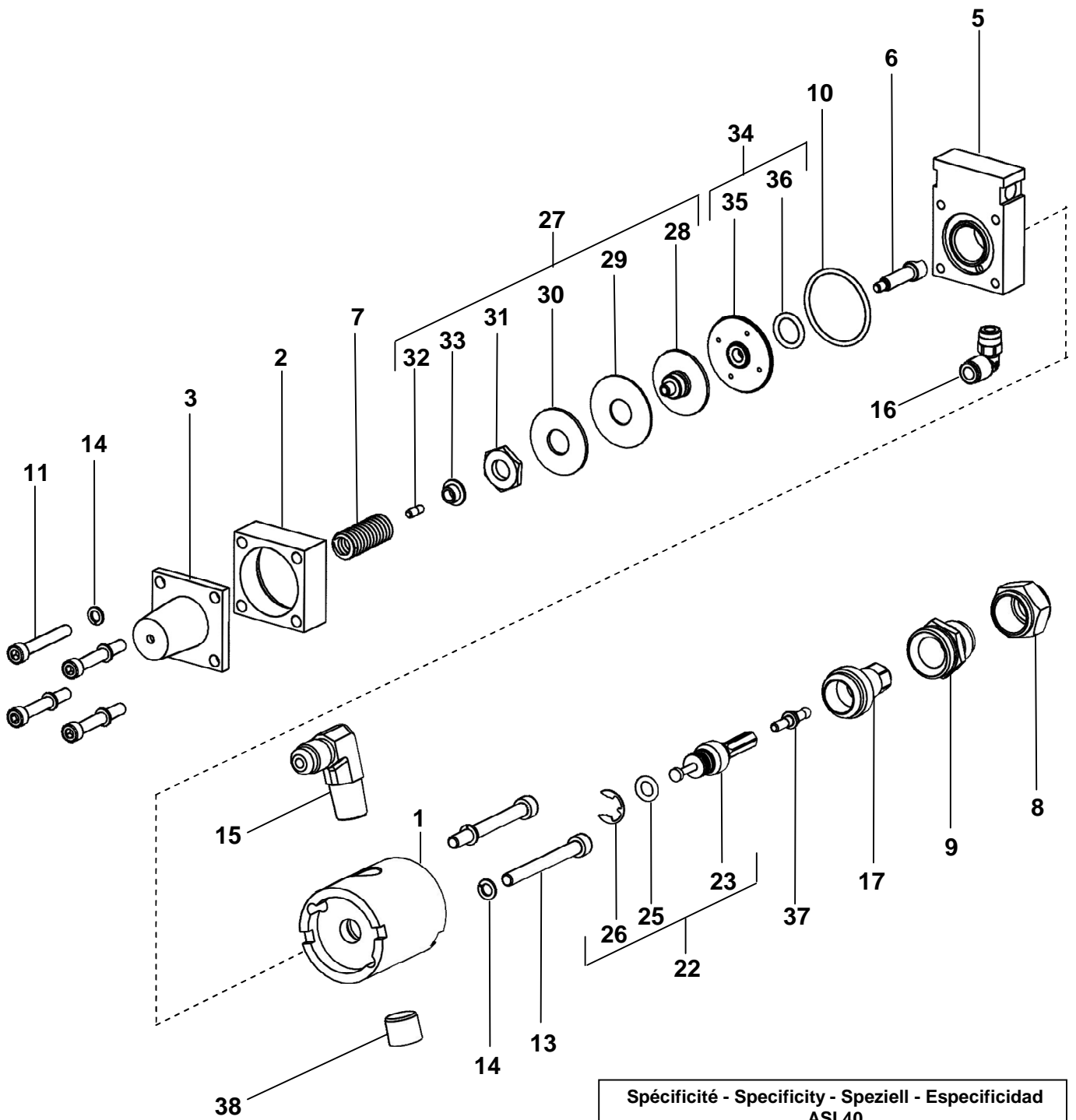

Ind	#	Désignation	Description	Bezeichnung	Denominación	Qté
1	029 980 001	Corps inox	Body, stainless steel	Körper, Edelstahl	Cuerpo inox	1
2	029 980 002	Cylindre	Cylinder	Zylinder	Cilindro	1
3	029 980 003	Guide du ressort	Guide, spring	Federführung	Guía del muelle	1
5	029 970 002	Support	Support	Halterung	Soporte	1
6	029 970 004	Entraîneur de pointeau	Rod strainer	Farbnadelmitnehmer	Varilla de la aguja	1
8	000 152 290	Ecrou de fixation	Nut, coupling	Befestigungsschraube	Tuerca de fijación	1
9	000 029 160	Diaphragme 060	Diaphragm 060	Vorzerstäuber 060	Restrictor 060	1
*10	129 479 913	Joint de cylindre (x 10)	Seal, cylinder (x 10)	Zylinderdichtung (10 St.)	Junta del cilindro (x 10)	1
11	933 151 441	Vis CHc M 5 x 35	Screw, CHc M 5 x 35	Schraube CHc M 5 x 35	Tornillo CHc M 5 x 35	4
13	933 151 546	Vis CHc M 5 x 50	Screw, CHc M 5 x 50	Schraube CHc M 5 x 50	Tornillo CHc M 5 x 50	2
14	963 210 014	Rondelle WZ 5	Washer, WZ 5	Scheibe WZ 5	Arandela WZ 5	6
15	905 210 602	Raccord coudé (inox) M 1/4 NPT - M 1/2 JIC	Elbow fitting, stainless steel, double male, 1/4 NPT - 1/2 JIC	Winkelniessel (Edelstahl) AG 1/4 NPT - AG 1/2 JIC	Racor acodado (inox) M 1/4 NPT - M 1/2 JIC	1
16	905 120 902	Raccord équerre M 1/8 G - Tuyau 4 x 6	Elbow fitting, M 1/8 G - Hose 4 x 6	Winkel Steckniessel AG 1/8 G - Schlauch 4 x 6	Racor codo a 90° M 1/8 G - Tubería 4 x 6	1
17	129 461 300	Porte siège assemblé	Seat holder assembly	Düsennadelsitz	Porta-asiento equipado	1
*22	129 971 100	Cartouche assemblée	Fluid packing assembly	Packungspatrone, kpl.	Cartucho equipado	1
23	NC / NS	▪ Cartouche	▪ Fluid packing	▪ Packung	▪ Cartucho	1
*25	129 971 002	▪ Joint (x 10)	▪ Seal (x 10)	▪ O-Ring (10 St.)	▪ Junta (x 10)	1
*26	102 201 914	▪ Circlips (x 10)	▪ Circlips (x 10)	▪ Sicherungsring (10 St.)	▪ Circlips (x 10)	1
*27	129 970 100	Piston assemblé	Piston assembly	Kolben, komplett	Pistón equipado	1
28	029 970 101	▪ Piston seul	▪ Piston only	▪ Kolben, allein	▪ Pistón solo	1
*29	029 970 102	▪ Garniture de piston	▪ Packing, piston	▪ Kolbenmanschette	▪ Guarnición de pistón	1
30	029 970 103	▪ Rondelle d'appui	▪ Support washer	▪ Stützscheibe	▪ Arandela de apoyo	1
31	029 970 104	▪ Ecrou	▪ Nut	▪ Mutter	▪ Tuerca	1
32	029 970 105	▪ Pion témoin	▪ Opening / closing indicator	▪ Öffnungsanzeiger	▪ Peón testigo	1
33	029 980 004	▪ Appui ressort	▪ Support, spring	▪ Federhalter	▪ Apoyo muelle	1
*34	129 970 200	Garniture air assemblée	Air packing assembly	Luftpackung, komplett	Guarnición de aire equipada	1
35	NC / NS	▪ Garniture air	▪ Air packing	▪ Luftpackung	▪ Guarnición de aire	1
*36	129 979 902	▪ Joint de garniture (x 10)	▪ O-Ring (x 10)	▪ O Ring (10 St.)	▪ Junta (x 10)	1
37	129 529 915	Pointeau bille (Ø 3,97)	Needle with ball (Ø 3.97)	Farbnadel mit Kugel (Ø 3,97)	Aguja bola (Ø 3,97)	1
38	905 210 303	Bouchon 1/4" inox (entrée produit)	Plug, 1/4", stainless steel (material inlet)	Stopfen, 1/4", Edelstahl (Materialeingang)	Tapón 1/4", inox (entrada producto)	1

ASI 24 : Pièces spécifiques - Specific parts - Spezifische Teile - Partes específicas

7	050 317 202	Ressort (P < 240 bar)	Spring (P < 240 bar / 3480 psi)	Feder (P < 240 bar)	Muelle (P < 240 bar)	1
---	-------------	--------------------------	------------------------------------	------------------------	-------------------------	---

ASI 40 : Pièces spécifiques - Specific parts - Spezifische Teile - Partes específicas

4	050 319 206	Ressort (P < 400 bar)	Spring (P < 400 bar / 5800 psi)	Feder (P < 400 bar)	Muelle (P < 400 bar)	1
---	-------------	--------------------------	------------------------------------	------------------------	-------------------------	---

↶ pour peintures hydrodiluable et peintures UV / for water-based paints and UV paints /
für Wasser- und UV-Lacke / para pinturas hidrosolubles y pinturas UV

ASI 40 GT # 129.980.600

ASI 40 GT V # 129.980.650

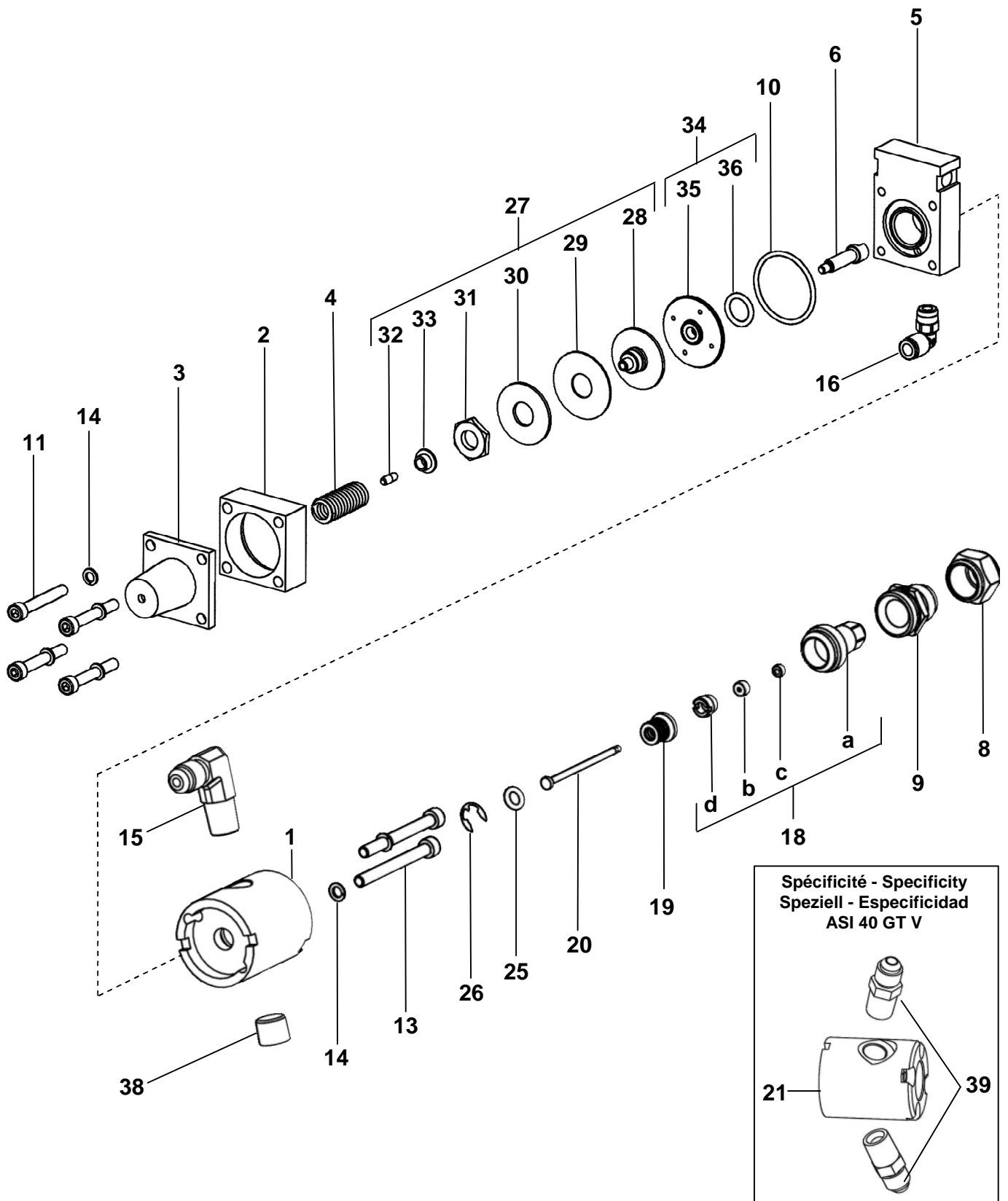

Ind	#	Désignation	Description	Bezeichnung	Denominación	Qté
2	029 980 002	Cylindre	Cylinder	Zylinder	Cilindro	1
3	029 980 003	Guide du ressort	Guide, spring	Federführung	Guía del muelle	1
4	050 319 206	Ressort (P < 400 bar)	Spring (P < 400 bar / 5800 psi)	Feder (P < 400 bar)	Muelle (P < 400 bar)	1
5	029 970 002	Support	Support	Halterung	Soporte	1
6	029 970 004	Entraîneur de pointeau	Rod strainer	Farbnadelmitnehmer	Varilla de la aguja	1
8	000 152 290	Ecrou de fixation	Nut, coupling	Befestigungsschraube	Tuerca de fijación	1
9	000 029 160	Diaphragme 060	Diaphragm 060	Vorzerstäuber 060	Restrictor 060	1
*10	129 479 913	Joint de cylindre (x 10)	Seal, cylinder (x 10)	Zylinderdichtung (10 St.)	Junta del cilindro (x 10)	1
11	933 151 441	Vis CHc M 5 x 35	Screw, CHc M 5 x 35	Schraube CHc M 5 x 35	Tornillo CHc M 5 x 35	4
13	933 151 546	Vis CHc M 5 x 50	Screw, CHc M 5 x 50	Schraube CHc M 5 x 50	Tornillo CHc M 5 x 50	2
14	963 210 014	Rondelle WZ 5	Washer, WZ 5	Scheibe WZ 5	Arandela WZ 5	6
16	905 120 902	Raccord équerre M 1/8 G - Tuyau 4 x 6	Elbow fitting, M 1/8 G - Hose 4 x 6	Winkel Stecknippel AG 1/8 G - Schlauch 4 x 6	Racor codo a 90° M 1/8 G - Tubería 4 x 6	1
18	129 980 100	Porte siège assemblé (siège inox)	Seat holder assembly (stainless steel seat)	Düsennadelsitz, kpl. (Sitz in Edelstahl)	Porta-asiento equipado (Asiento inox)	1
a	NC / NS	▪ Porte-siège (sans siège)	▪ Seat holder (without seat)	▪ Düsennadelsitz (ohne Einsatz)	▪ Porta-asiento (sin asiento)	1
*b	129 679 905	▪ Siège en inox (x 2)	▪ Seat, stainless steel (x 2)	▪ Edelstahl-Einsatz (2 st.)	▪ Asiento en inox (x 2)	1
*c	129 629 922	▪ Joint (x 10)	▪ Seal (x 10)	▪ Dichtung (10 St.)	▪ Junta (x10)	1
d	029 600 106	▪ Vis	▪ Screw	▪ Schraube	▪ Tornillo	1
*19	129 980 310	Cartouche GT	GT packing	GT-Packung	Cartucho GT	1
*20	033 980 100	Pointeau bille (Ø 2,5)	Needle with ball (Ø 2.5)	Farbnadel mit Kugel (Ø 2,5)	Aguja bola (Ø 2,5)	1
*25	129 971 002	Joint (x 10)	Seal (x 10)	O-Ring (10 St.)	Junta (x 10)	1
*26	102 201 914	Circlips (x 10)	Circlips (x 10)	Sicherungsring (10 St.)	Circlips (x 10)	1
*27	129 970 100	Piston assemblé	Piston assembly	Kolben, komplett	Pistón equipado	1
28	029 970 101	▪ Piston seul	▪ Piston only	▪ Kolben, einzeln	▪ Pistón solo	1
*29	029 970 102	▪ Garniture de piston	▪ Packing, piston	▪ Kolbenmanschette	▪ Guarnición de pistón	1
30	029 970 103	▪ Rondelle d'appui	▪ Support washer	▪ Stützscheibe	▪ Arandela de apoyo	1
31	029 970 104	▪ Ecrou	▪ Nut	▪ Mutter	▪ Tuerca	1
32	029 970 105	▪ Pion témoin	▪ Opening / closing indicator	▪ Öffnungsanzeiger	▪ Peón testigo	1
33	029 980 004	▪ Appui ressort	▪ Support, spring	▪ Federhalter	▪ Apoyo muelle	1
*34	129 970 200	Garniture air assemblée	Air packing assembly	Luftpackung, komplett	Guarnición de aire equipada	1
35	NC / NS	▪ Garniture air	▪ Air packing	▪ Luftpackung	▪ Guarnición de aire	1
*36	129 979 902	▪ Joint de garniture (x 10)	▪ O-Ring (x 10)	▪ O Ring (10 St.)	▪ Junta (x 10)	1

ASI 40 GT : Pièces spécifiques - Specific parts - Spezifische Teile - Partes específicas

1	029 980 001	Corps inox	Body, stainless steel	Körper, Edelstahl	Cuerpo inox	1
15	905 210 602	Raccord coudé (inox) M 1/4 NPT - M 1/2 JIC	Elbow fitting, stainless steel, double male, 1/4 NPT - 1/2 JIC	Winkelnippel (Edelstahl) AG 1/4 NPT - AG 1/2 JIC	Racor acodado (inox) M 1/4 NPT - M 1/2 JIC	1
38	905 210 303	Bouchon 1/4" inox (entrée produit)	Plug, 1/4", stainless steel (material inlet)	Stopfen, 1/4", Edelstahl (Materialeingang)	Tapón 1/4", inox (entrada producto)	1

ASI 40 GT V : Pièces spécifiques - Specific parts - Spezifische Teile - Partes específicas

Ind	#	Désignation	Description	Bezeichnung	Denominación	Qté
21	029 980 005	Corps inox	Body, stainless steel	Körper, Edelstahl	Cuerpo inox	1
39	905 210 502	Raccord droit inox M 1/4 NPT - M 1/2 JIC	Straight fitting, stainless steel, double male, 1/4 NPT - 1/2 JIC	Gerader Nippel Edelstahl AG 1/4 NPT - AG 1/2 JIC	Racor recto inox M 1/4 NPT - 1/2 JIC	2

Ind	#	Désignation	Description	Bezeichnung	Denominación	Qté
*	129 980 901	Pochette de joints (rep. 10, 25, 26, 29, 36)	Repair kit (ind. 10, 25, 26, 29, 36)	Reparatursatz (Pos. 10, 25, 26, 29, 36)	Kit de juntas (índ. 10, 25, 26, 29, 36)	1
-	049 351 000	Support de fixation (Ø 16 - longueur 100 mm)	Mounting rod (Ø 16 - length 100 mm)	Pistolenhalterung (Ø 16 - Länge 100 mm)	Soporte de fijación (Ø 16 - longitud 100 mm)	1

ACCESSOIRES - ACCESSORIES - ZUBEHÖR - ACCESORIOS

BUSES PLATES - FLAT TIPS - FLACHSTRAHL DÜSEN - BOQUILLAS PLANAS

: 000 00 XX XX remplacer les X par leur nombre gravé sur la buse / replace X by the number engraved on the tip / die X durch die auf der Düse eingravierte Nummer ersetzen / sustituir las X por las cifras gravadas en la boquilla

Calibre Size Größe	Ø. mm	Débit d'eau Water output Wasserdurchsatz Caudal agua (l / mn) Pression / Pressure / Druck / Presión 140 bar / 2030 psi	Diaphragme buse / Tip diaphragm / Vorzerstäuber / Restrictor boquilla	Largeur de jet à 25 cm / Spray fan width at 25 cm (10") Strahlbreite bei 25 cm Abstand / Ancho abanico à 25 cm											
				8	13	18	23	28	33	38	43	48	53		
03	0,18	0,23	09	03.03	03.05	03.07									
04	0,23	0,31	09	04.03	04.05	04.07	04.09	04.11	04.13						
06	0,28	0,46	12	06.03	06.05	06.07	06.09	06.11	06.13	06.15					
09	0,33	0,63	15	09.03	09.05	09.07	09.09	09.11	09.13	09.15	09.17				
12	0,38	0,86	15			12.07	12.09	12.11	12.13	12.15	12.17	12.19			
14	0,41	1,01	18	14.03	14.05	14.07	14.09	14.11	14.13	14.15	14.17				
18	0,46	1,34	18									18.17	18.19		
20	0,51	1,50	20		20.05	20.07	20.09	20.11	20.13	20.15	20.17	20.19			
25	0,56	1,88	20						25.13						
30	0,61	2,25	25			30.07	30.09	30.11	30.13	30.15	30.17	30.19			
45	0,74	3,34	25			45.07		45.11	45.13	45.15	45.17	45.19	45.21		

Le diaphragme augmente la finesse de pulvérisation - # : 000 029 1XX (remplacer les X par le nombre du diaphragme).

The diaphragm increases the quality finish - # : 000 029 1XX (replace X by the diaphragm number).

Der Vorzerstäuber verfeinert die Zerstäubung - # : 000 029 1XX (X durch die Nummer des Vorzerstäubers ersetzen).

El restrictor aumenta la calidad (finura) del pulverizado - # : 000 029 1XX (sustituir las X por las cifras gravadas en el restrictor).

**BUSES A JET REGLABLE - ADJUSTABLE FAN TIPS
DÜSE MIT EINSTELLBAREM SPRITZSTRAHL - BOQUILLAS DE ABANICO REGULABLE**

Calibre Tip size Größe	Buse équivalente à une buse plate / Equivalent with flat tip / entspricht folgenden Flachstrahl Düsen / Boquilla equivalente a una boquilla plana		# Buse / Tip / Düse / Boquilla	# Aiguille débouchage / Unclogging needle / Reinigungsnadeln / Aguja desobturadora
	minimum / mínimo	maximum / máximo		
28	06	20	100 000 620	000 000 621
41	14	68	100 001 468	000 001 469

* Pièces de maintenance préconisées.

* Preceding the index number denotes a suggested spare part.

* Bezeichnete Teile sind empfohlene Ersatzteile.

* Piezas de mantenimiento preventivas.

N C : Non commercialisé.

N S : Denotes parts are not serviceable.

N S : Bezeichnete Teile gibt es nicht einzeln, sondern nur komplett.

N S : No suministrado.

Doc. 573.327.050 Date/Datum/Fecha : 10/10/11 Annule/Cancel/ Ersetzt/Anula : 08/12/09	Modif. /Änderung : Mise à jour / Update / Aktualisierung / Actualización	Pièces de rechange Spare parts list Ersatzteilliste Piezas de repuesto
--	---	---

FILTRE PRODUIT HP, modèle 3/4 inox	HP FLUID FILTER, model 3/4 stainless steel
HP MATERIALFILTER, Modell 3/4 Edelstahl	FILTRO PRODUCTO HP, tipo 3/4 inox

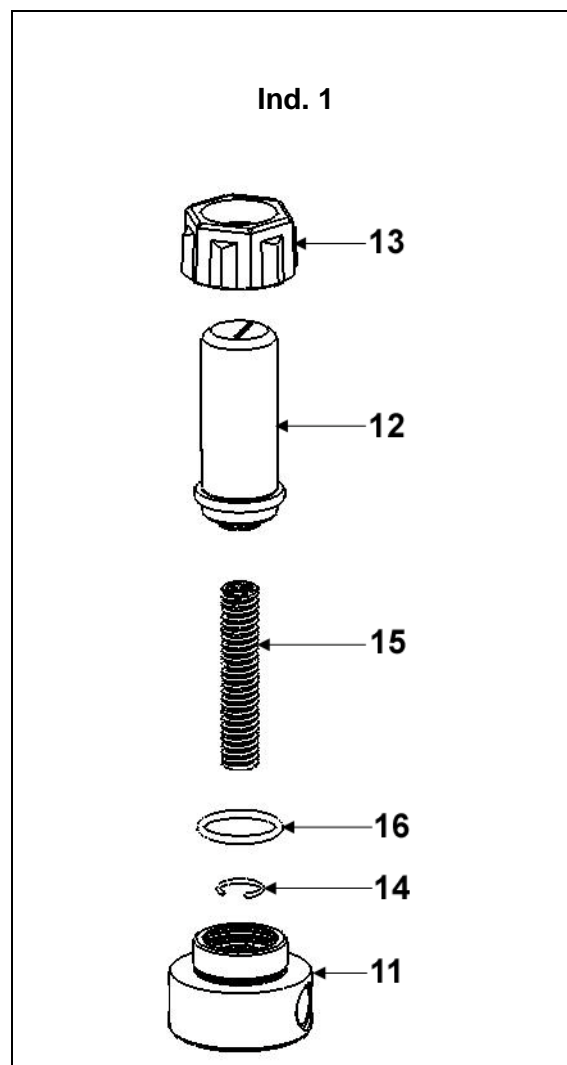
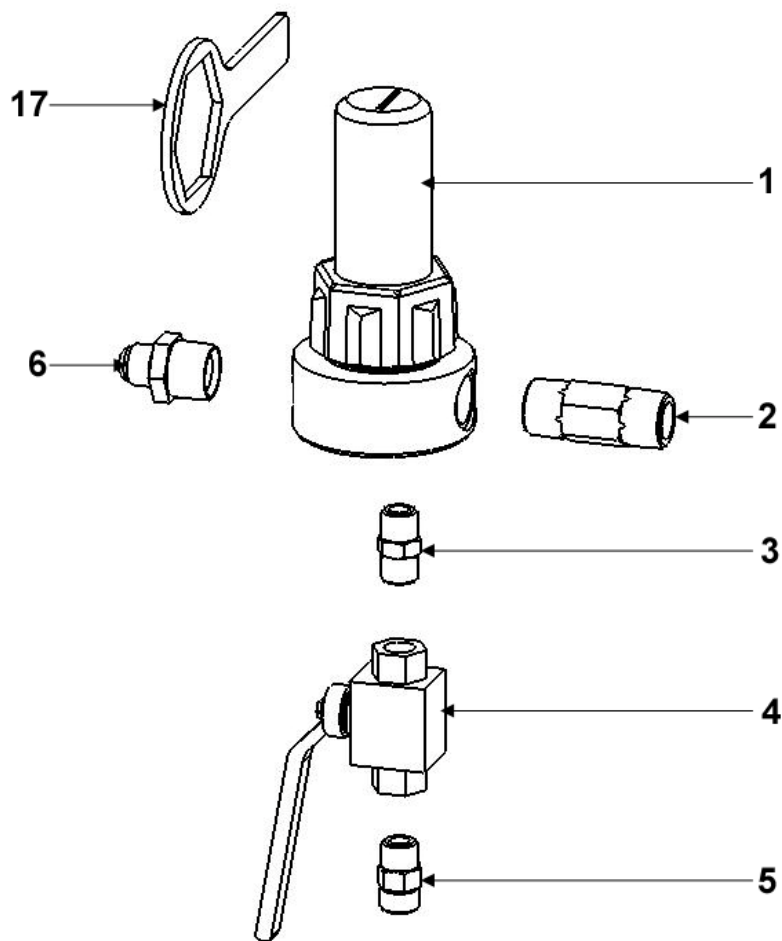

FILTRE EQUIPÉ pour pompes AIRLESS®	EQUIPPED FILTER for AIRLESS pumps	# 155.581.400
AUSGERÜSTETER FILTER für AIRLESS®-Pumpen	FILTRO EQUIPADO para bombas AIRLESS®	

Ind	#	Désignation	Description	Bezeichnung	Denominación	Qté
* 1	155.581.450	Filtre nu inox (voir détail)	Bare filter, stainless steel (See detail)	Nackter Filter – Edelstahl (Siehe Detail)	Filtro solo, inox (ver detalle)	1
2	055.581.401	Mamelon inox 3/4 NPS	Nippel 3/4 NPS, stainless steel	Rohnippel ¾ NPS, Edelstahl	Pivote de centrado inox 3/4 NPS	1
3	905.240.002	Raccord inox MM 3/8 NPT	Fitting, double male, 3/8 NPT	Doppelnippel AG 3/8 NPT	Racor inox, MM 3/8 NPT	1
* 4	903.090.220	Vanne HP FF 3/8 BSP	HP valve FF 3/8 BSP	Kugelhahn, IG 3/8 BSP	Válvula, HH 3/8 BSP	1
5	050.102.436	Raccord inox M 18 x 125 - M 3/8 BSP	Adaptor, stainless steel, double male 18x125 - 3/8BSP	Doppelnippel - Edelstahl AG 3/8 BSP - M 18x1,25	Racor inox, M 18 x 125 - M 3/8 BSP	1
6	905.210.515	Raccord inox M 3/4 NPT - M 3/4 JIC	Adaptor, stainless steel, double male, 3/4 NPT - # 8 JIC (3/4 JIC)	Doppelnippel Edelstahl 3/4 NPT – 3/4 JIC	Racor, inox M 3/4 NPT - M 3/4 JIC	1
* 7	000.161.112	Tamis n° 12 (280 µ)	Screen n° 12 (280 µ - 55 Mesh)	Filterelement Sieb Nr. 12 (280 µ)	Tamiz n° 12 (280 µ)	1

FILTRE NU (sans tamis)	BARE FILTER (without screen)	# 155.581.450
NACKTER FILTER (ohne Sieb)	FILTRO SOLO (sin tamiz)	

Ind	#	Désignation	Description	Bezeichnung	Denominación	Qté
11	055.581.451	Embase 3/4	Base, model 3/4	Grundblock, Modell 3/4	Base, tipo 3/4	1
12	055.580.202	Cuve	Bowl	Filterglocke	Cubeta	1
13	055.280.002	Ecrou	Nut	Überwurfmutter	Tuerca	1
14	055.190.007	Jonc	Stop ring	Sicherungsring	Clips	1
15	055.190.005	Ressort	Spring	Feder	Muelle	1
* 16	150.040.327	Joint (les 5)	Seal (pack of 5)	Dichtung (5 St.)	Junta (bolsa de 5)	1
17	049.030.018	Clé de démontage	Wrench	Schlüssel	Llave de desmontaje	1

- * Pièces de maintenance préconisées tenues en stock
- * Preceding the index number denotes a suggested spare part.
- * Bezeichnete Teile sind empfohlene Ersatzteile.
- * Piezas de mantenimiento preventivas a tener en stock.

Ind. 7



Ind	#	Désignation	Description	Bezeichnung	Denominación	Qté
-	000.161.101	Tamis n° 1 (37 µ)	Screen n° 1 (37 µ)	Sieb Nr. 1 (37 µ)	Tamiz n° 1 (37µ)	1
-	000.161.102	Tamis n° 2 (77 µ)	Screen n° 2 (77 µ)	Sieb Nr. 2 (77 µ)	Tamiz n° 2 (77 µ)	1
-	000.161.104	Tamis n° 4 (99 µ)	Screen n° 4 (99 µ)	Sieb Nr. 4 (99 µ)	Tamiz n° 4 (99 µ)	1
-	000.161.106	Tamis n° 6 (168 µ)	Screen n° 6 (168 µ)	Sieb Nr. 6 (168 µ)	Tamiz n° 6 (168 µ)	1
-	000.161.108	Tamis n° 8 (210 µ)	Screen n° 8 (210 µ)	Sieb Nr. 8 (210 µ)	Tamiz n° 8 (210 µ)	1
7	000.161.112	Tamis n° 12 (280 µ)	Screen n° 12 (280 µ)	Sieb Nr. 12 (280 µ)	Tamiz n° 12 (280 µ)	1
-	000.161.115	Tamis n° 15 (360 µ)	Screen n° 15 (360 µ)	Sieb Nr. 15 (360 µ)	Tamiz n° 15 (360 µ)	1
-	000.161.020	Tamis n° 20 (510 µ)	Screen n° 20 (510 µ)	Sieb Nr. 20 (510 µ)	Tamiz n° 20 (510 µ)	1
-	000.161.030	Tamis n° 30 (750 µ)	Screen n° 30 (750 µ)	Sieb Nr. 30 (750 µ)	Tamiz n° 30 (750 µ)	1

OPTIONS - ON REQUEST - OPTIONEN - OPCIONES

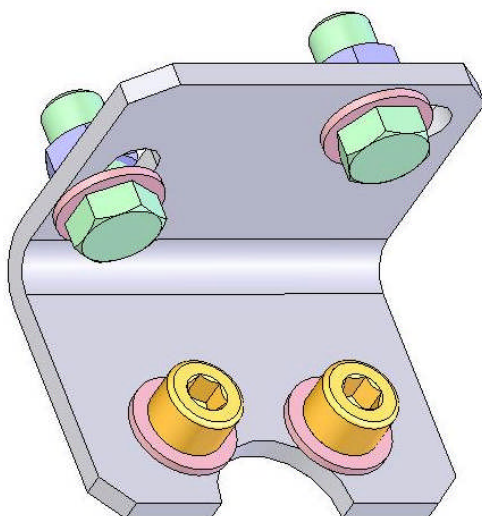

Ind	#	Désignation	Description	Bezeichnung	Denominación	Qté
-	155.190.105	Support filtre avec vis, rondelles et écrous	Mounting bracket with screws, washers and nuts	Filterhalterung mit Schrauben, Scheiben und Muttern	Soporte filtro con tornillos, arandelas y tuercas	1

Doc. 573.438.050 Date/Datum/Fecha : 13/12/13 Annule/Cancel/ Ersetzt/Anula :	Modif. / Änderung :	Pièces de rechange Spare parts list Ersatzteilliste Piezas de repuesto
---	----------------------------	---

POMPE DE RINCAGE POUR POMPE PU 3000, modèle EOS 30-C25	FLUSHING PUMP FOR PU 3000 PUMP, model EOS 30-C25
SPÜLPUMPE FÜR PU 3000 PUMPE, Modell EOS 30-C25	BOMBA DE LIMPIEZA PARA BOMBA PU 3000 , tipo EOS 30-C25

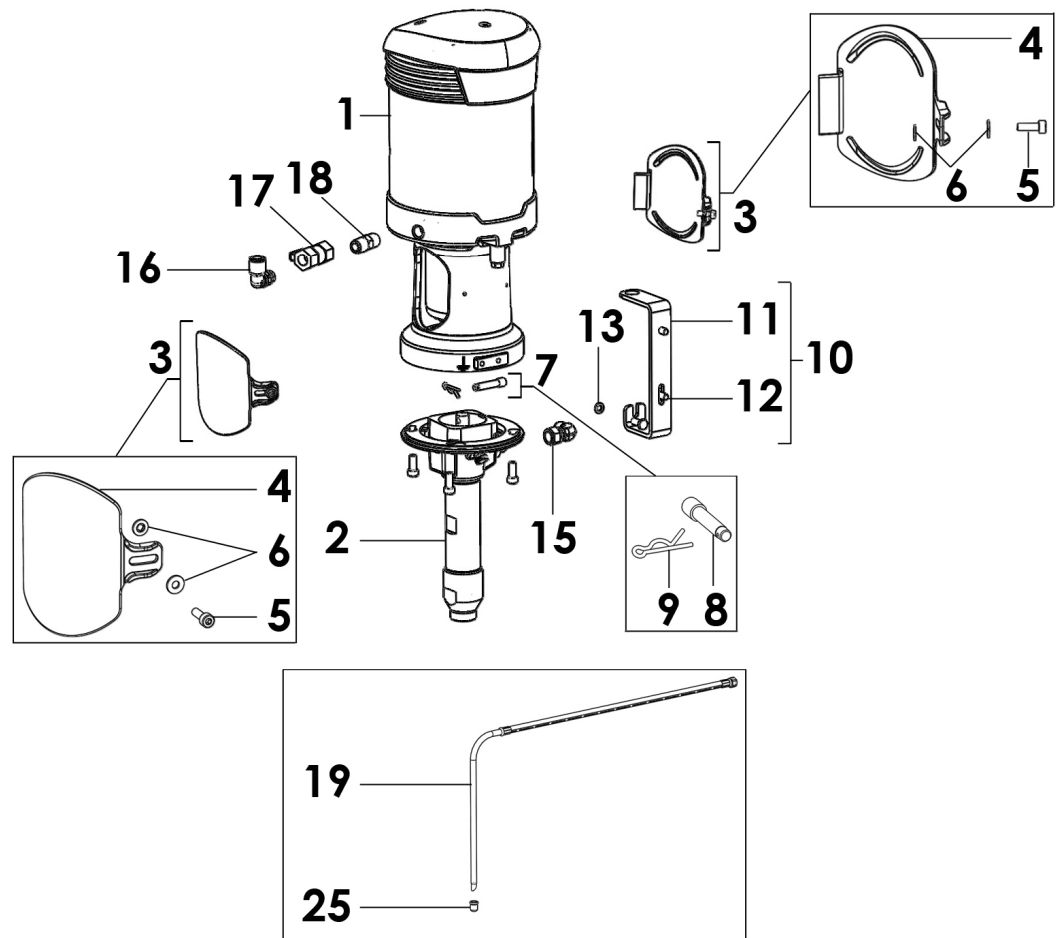

POMPE DE RINCAGE POUR POMPE PU 3000, modèle EOS 30-C25	FLUSHING PUMP FOR PU 3000 PUMP, model EOS 30-C25	# 151.145.090
SPULPUMPE FÜR PUMPE PU 3000, Modell EOS 30-C25	BOMBA DE LIMPIEZA PARA BOMBA PU 3000 tipo EOS 30-C25	

Ind	#	Désignation	Description	Bezeichnung	Denominación	Qté
-	-	Pompe nue inox	Bare pump, stainless steel	Pumpe nackt, Edelstahl	Bomba sola de inox	1
1	NC / NS	▪ Moteur 420-4 (voir Doc. 573.435.050)	▪ Air motor, model 420-4 (refer to Doc. 573.435.050)	▪ Luftmotor, Modell 420-4 (Siehe Dok. 573.435.050)	▪ Motor, tipo 420-4 (Consultar Doc. 573.435.050)	1
*2	144 130 200	▪ Hydraulique EOS C-25 (Entrée produit M 16x125) (voir Doc. 573.434.050)	▪ Fluid section, model EOS C-25 (Material inlet M 16x125) (refer to Doc. 573.434.050)	▪ Hydraulikteil, Modell EOS C-25 (Materialeingang AG M16x1,25) (Siehe Dok. 573.434.050)	▪ Hidráulica, tipo EOS C-25 (Entrada producto M 16x125) (Consultar Doc. 573.434.050)	1
*3	144 130 013	▪ Kit cache accouplement	▪ Coupling housing kit	▪ Schutzdeckelkit	▪ Kit cárter de acoplamiento	1
4	NC / NS	• Cache accouplement	• Coupling housing	• Schutzdeckel	• Cárter de acoplamiento	2
5	NC / NS	• Vis	• Screw	• Schraube	• Tornillo	2
6	NC / NS	• Rondelle	• Washer	• Mutter	• Arandela	4
*7	144 130 019	▪ Kit accouplement	▪ Coupling kit	▪ Kupplungskit	▪ Kit de acoplamiento	1
8	NC / NS	• Axe	• Axe	• Achse	• Eje	1
9	NC / NS	• Goupille	• Pin	• Splint	• Pasador	2
*10	144 130 022	▪ Support mural	▪ Pump bracket	▪ Wandhalterung, kpl.	▪ Soporte de bomba	1
11	NC / NS	• Support mural	• Pump bracket	• Wandhalter	• Soporte de bomba	1
12	NC / NS	• Vis H 6x16	• Screw, model H 6x16	• Schraube, H 6x16	• Tornillo, tipo H 6x16	3
13	NC / NS	• Rondelle AZ6	• Washer, model AZ6	• Mutter, AZ6	• Arandela, tipo AZ6	1
-	144 130 195	Kit écrous, vis et tirants	Nuts, screws and tie-rods kit	Stehbolzen, Schraube und Mutter	Kit tuercas, tornillos y tirantes	1
-	NC / NS	▪ Ecrou	▪ Nut	▪ Mutter	▪ Tuerca	4
-	NC / NS	▪ Vis	▪ Screw	▪ Schraube	▪ Tornillo	8
-	NC / NS	▪ Tirant	▪ Tie-rod, connecting	▪ Stehbolzen	▪ Tirante	4
15	905 160 101	Raccord coudé F 1/2 JIC - M 1/2 JIC	Elbow connector, F 1/2 JIC - M 1/2 JIC	Winkelnippel IG 1/2 JIC - AG 1/2 JIC	Racor acodado, H 1/2 JIC - M 1/2 JIC	1
16	905 120 913	Raccord coudé 1/4G - T 8x10	Elbow connector 1/4G - T 8x10	Winkel Stecknippel 1/4G - T 8x10	Racor acodado 1/4G - T 8x10	1
17	903 090 806	Robinet FF 1/4	Valve, model FF 1/4	Absperrhahn IG/IG 1/4	Válvula, tipo HH 1/4	1
18	906 314 203	Raccord (inox 316L) MM 1/4 BSP	Fitting, double male, 1/4" (316L stainless steel)	Doppelnippel AG 1/4" - AG 1/4" (Edelstahl, 316L)	Racor (inox 316L) MM 1/4 BSP	1
19	149 596 050	Canne d'aspiration Ø 16	Suction rod Ø 16	Saugschlauch Ø 16	Caña de aspiración Ø 16	1
25	149 596 052	Crépine Ø 16	Strainer Ø 16	Siebkorb Ø 16	Piña Ø 16	1
-	050 450 651	Tuyau produit (Ø 4,8 mm, long. 0,6 m, raccords inox, 240 bar)	Fluid hose (3/16" dia, 0.6 m long, stainless steel hoses, 240 bar / 3481 psi)	Materialschlauch (Ø 4,8 mm, Länge: 0,6 m, Anschlüsse Edelstahl, 240 bar)	Tubería producto (Ø 4.8 mm, 0,6 m de largo, racores de inox, 240 bar)	1

ACCESSOIRES - ACCESSORIES - ZUBEHÖR - ACCESORIOS

Ind	#	Désignation	Description	Bezeichnung	Denominación	Qté
-	149 990 020	Flacon de lubrifiant T (125 ml)	T lubricant (125 ml / 4.4 oz)	Spülmittel T (125 ml)	Botella de lubricante T (125 ml)	1

* Pièces de maintenance préconisées.

* Preceding the index number denotes a suggested spare part.

* Bezeichnete Teile sind empfohlene Ersatzteile.

* Piezas de mantenimiento preventivas.

N C : Non commercialisé.

N S : Denotes parts are not serviceable.

N S : Bezeichnete Teile gibt es nicht einzeln, sondern nur komplett .

N S : no suministrado.

PU 3000

PU 3000

PU 3000

PU 3000

220 V
1 ph
1A

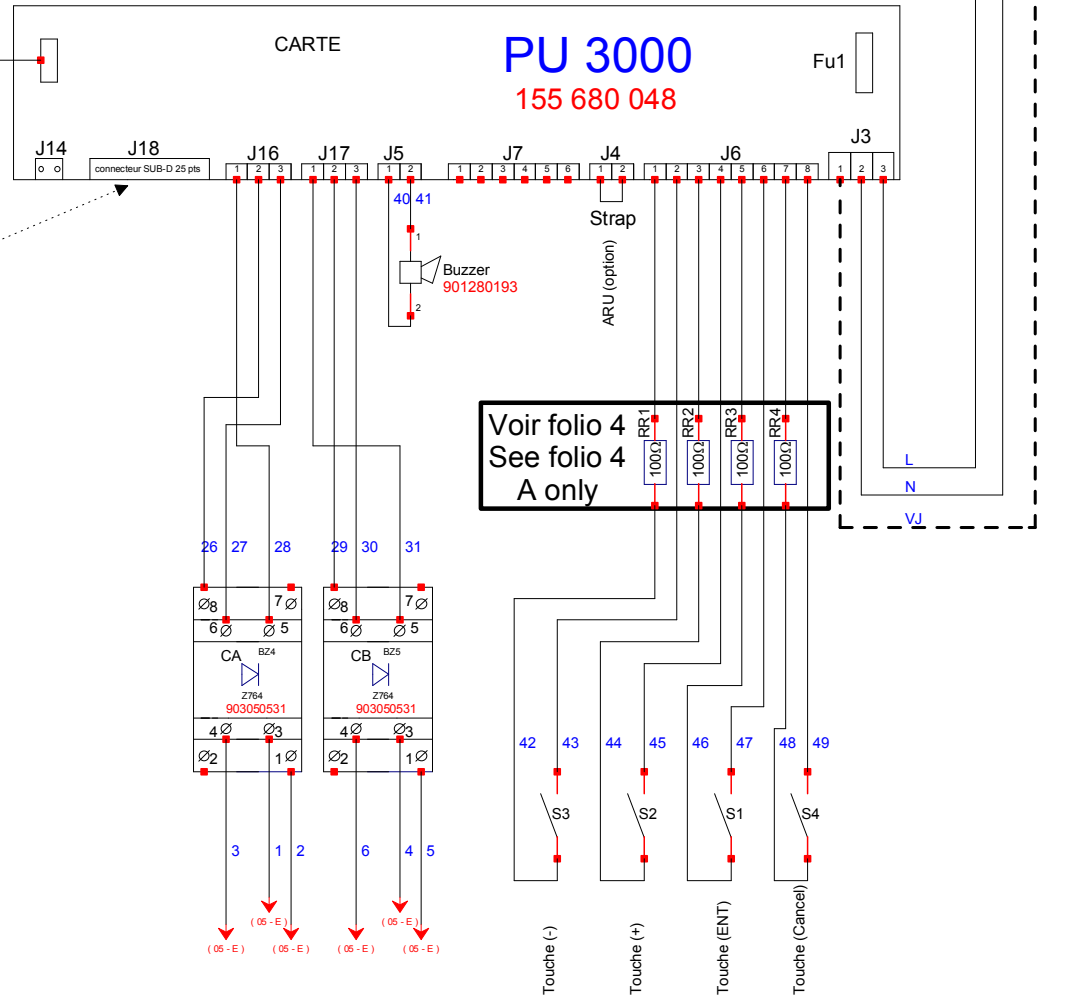
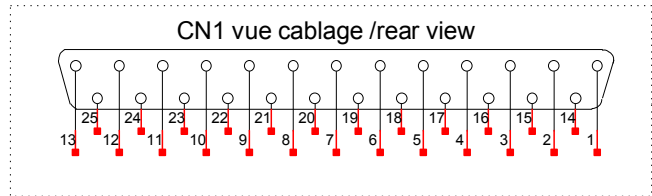
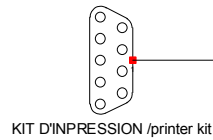
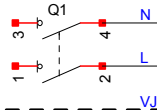

SUB D 25	
1	+24V
2	0V
14	IN
15	+24V
16	0V
3	IN
6	0V
18	+24V(OUT)
9	0V
21	+24V(OUT)
10	0V
22	+24V(OUT)
7	0V
19	+24V(OUT)
8	0V
20	+24V(OUT)
11	IN
23	+24V
12	0V
24	+24V(OUT)
13	0V
25	+24V(OUT)

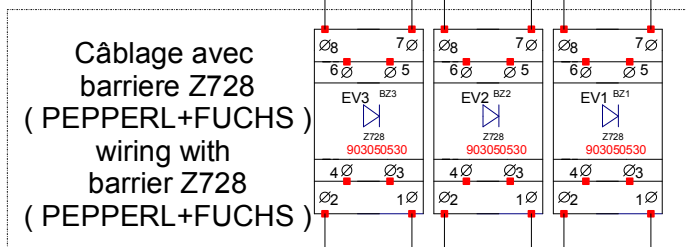
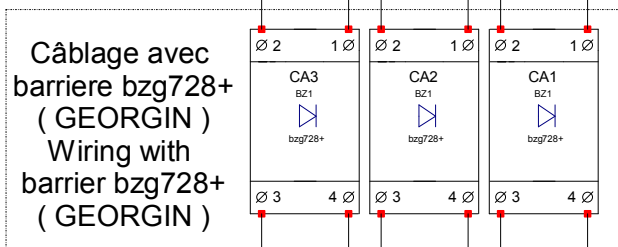
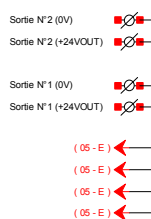
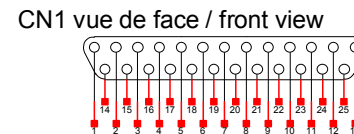
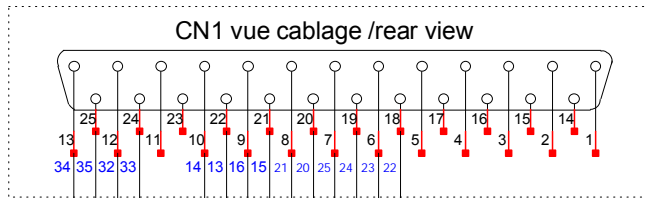

**Le câblage avec barriere bzg728+ (GEORGIN)
et le câblage avec barriere Z728 (PEPPERL+FUCHS)
l'un annule l'autre
For IS barrier you need to select the wiring diagram
depending of IS barrier used**

(05 - E) (05 - E) (05 - E) (05 - E)

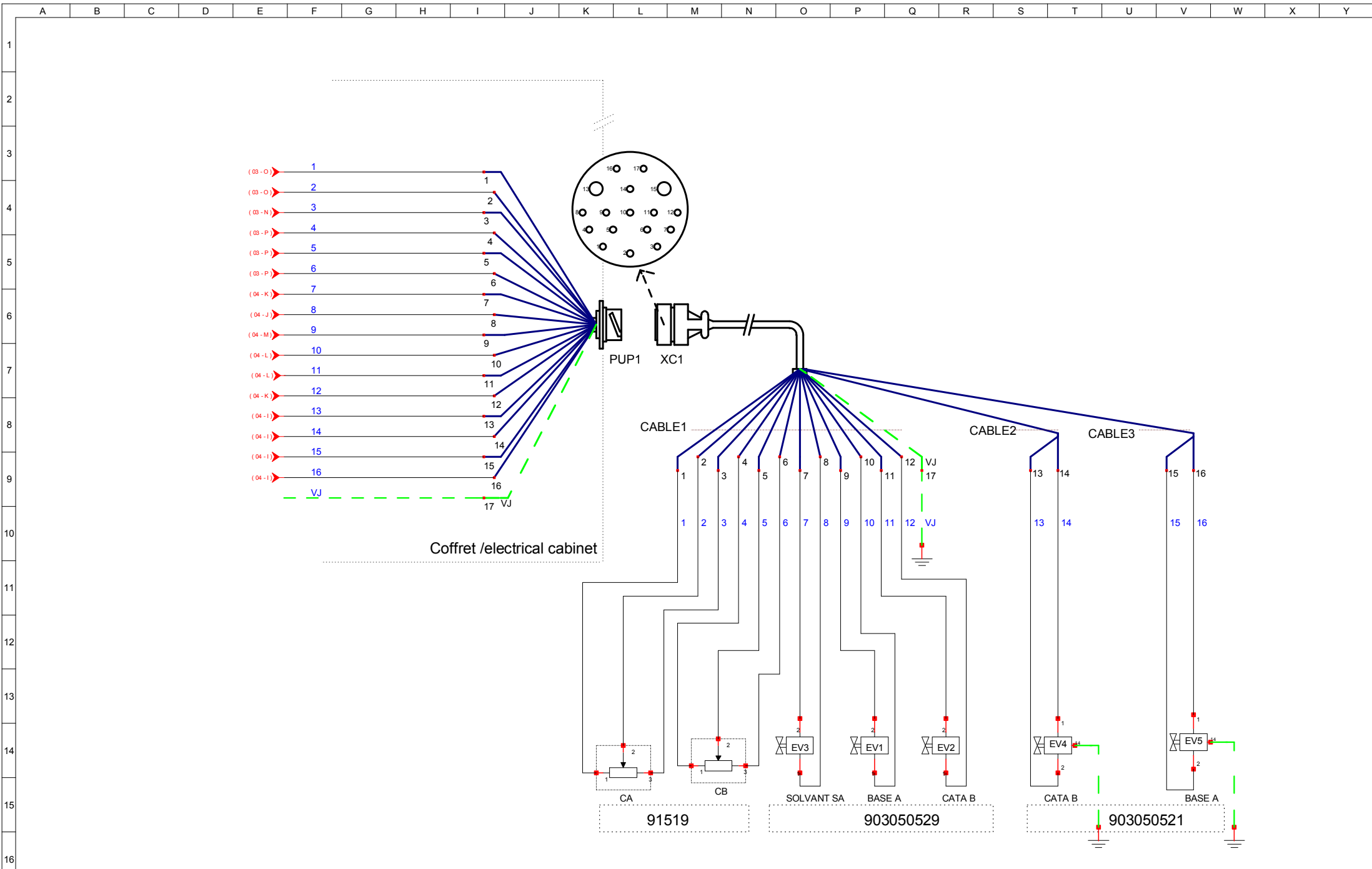

Ref EV1, EV2 et EV3 : 903050529

A

Ancienne carte Electronique
Sans led et résistance
Electronic board
Without DEL resistor

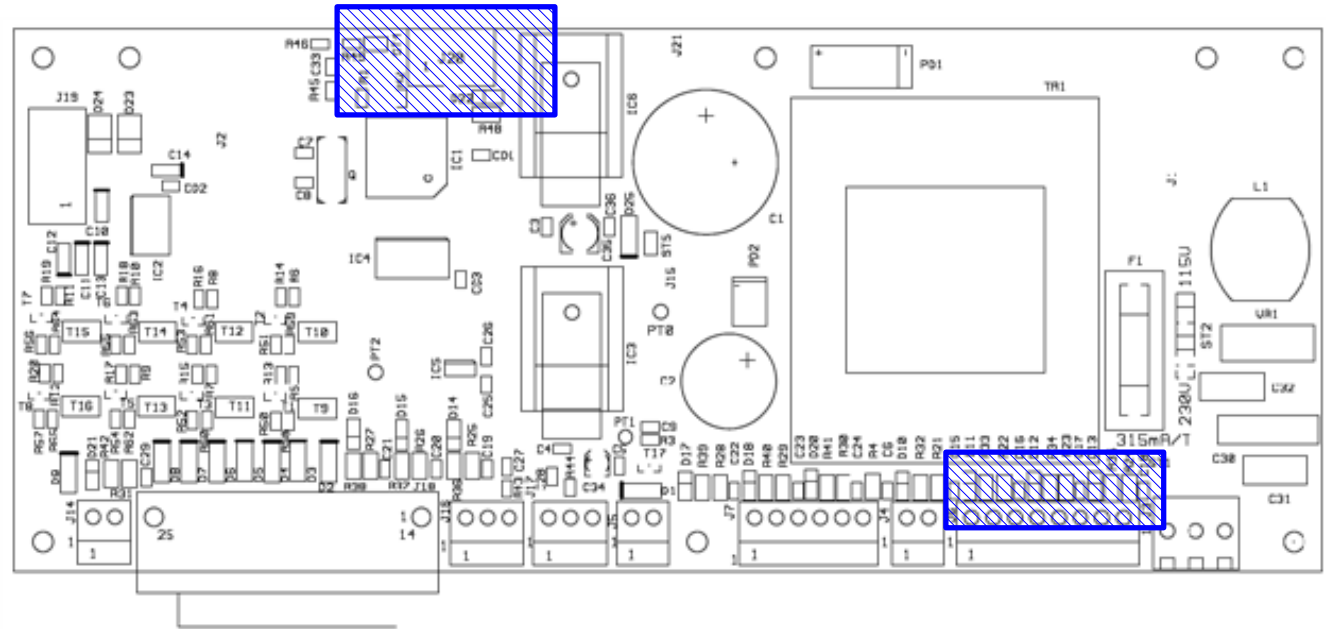

Nouvelle carte Electronique
Avec led et résistance
New electronic board
With DEL resistor

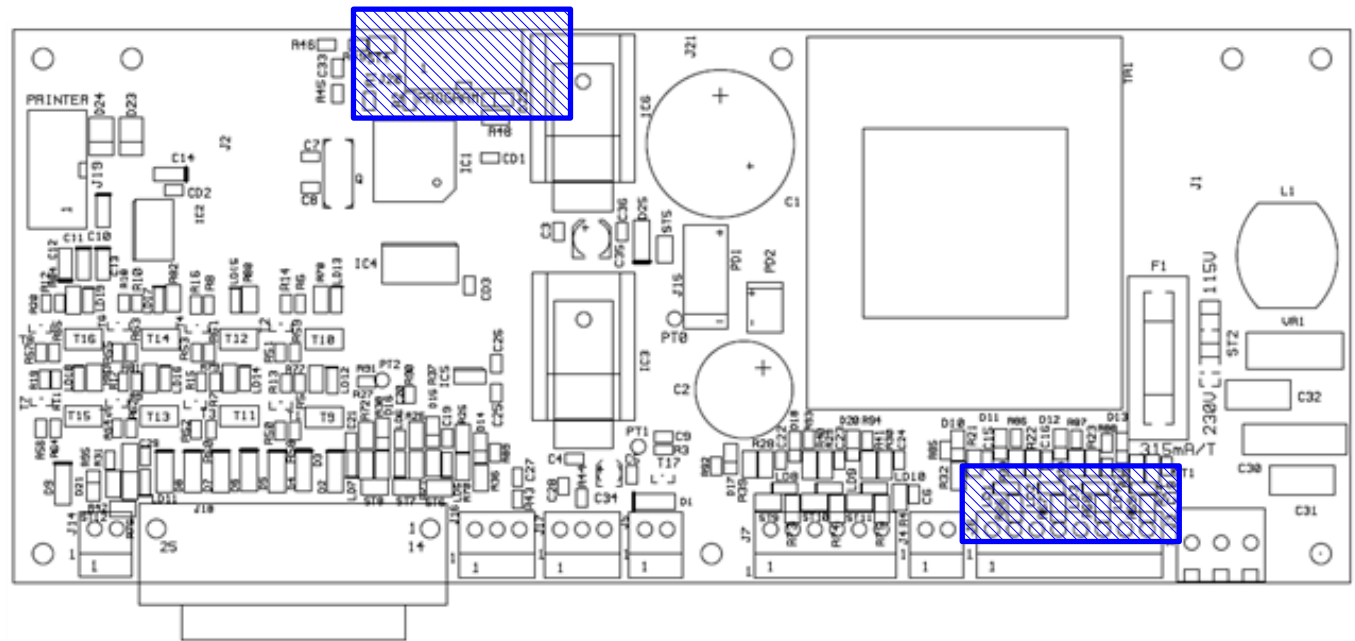

PU 3000

PU 3000

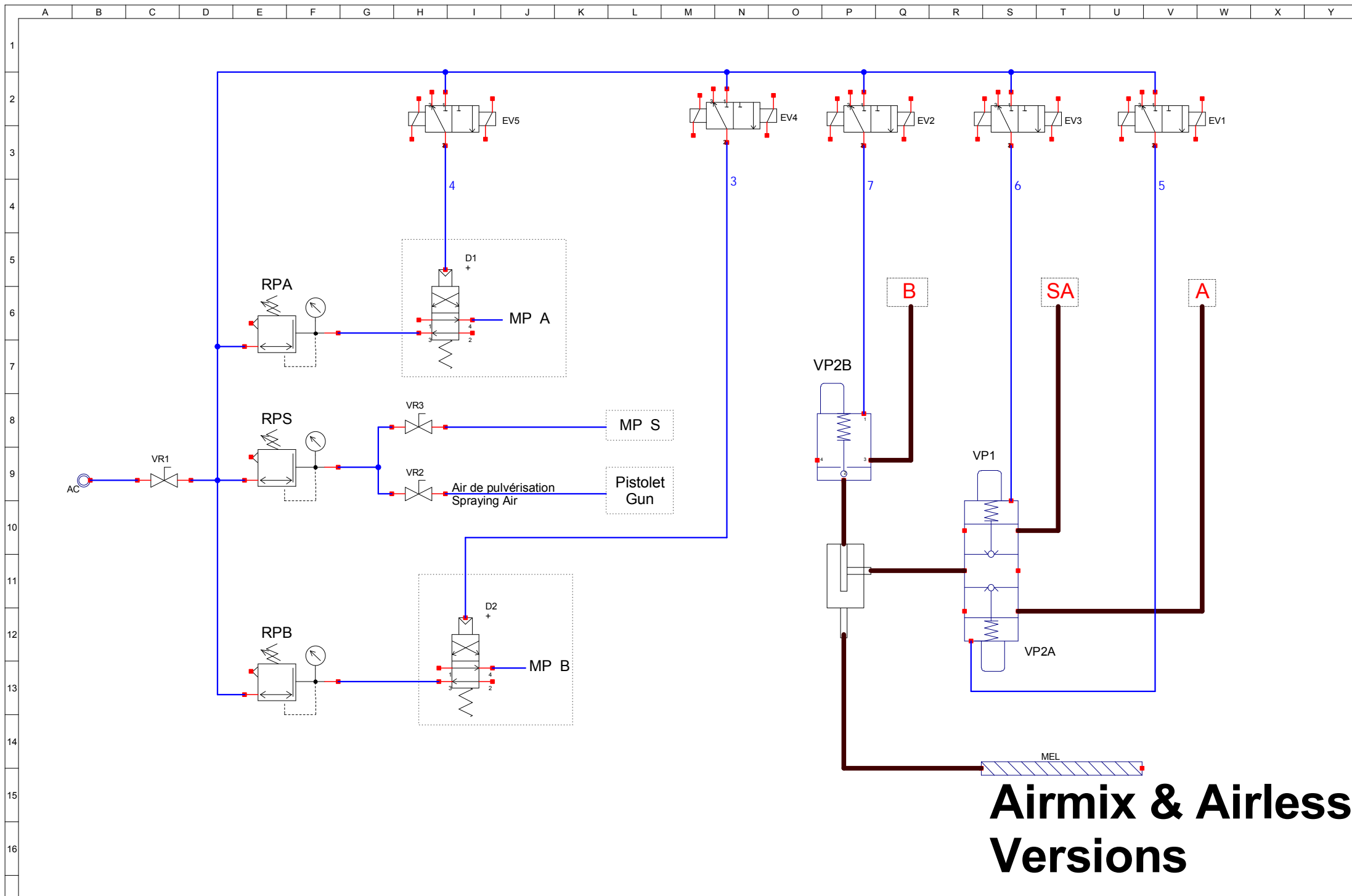

Airmix & Airless Versions

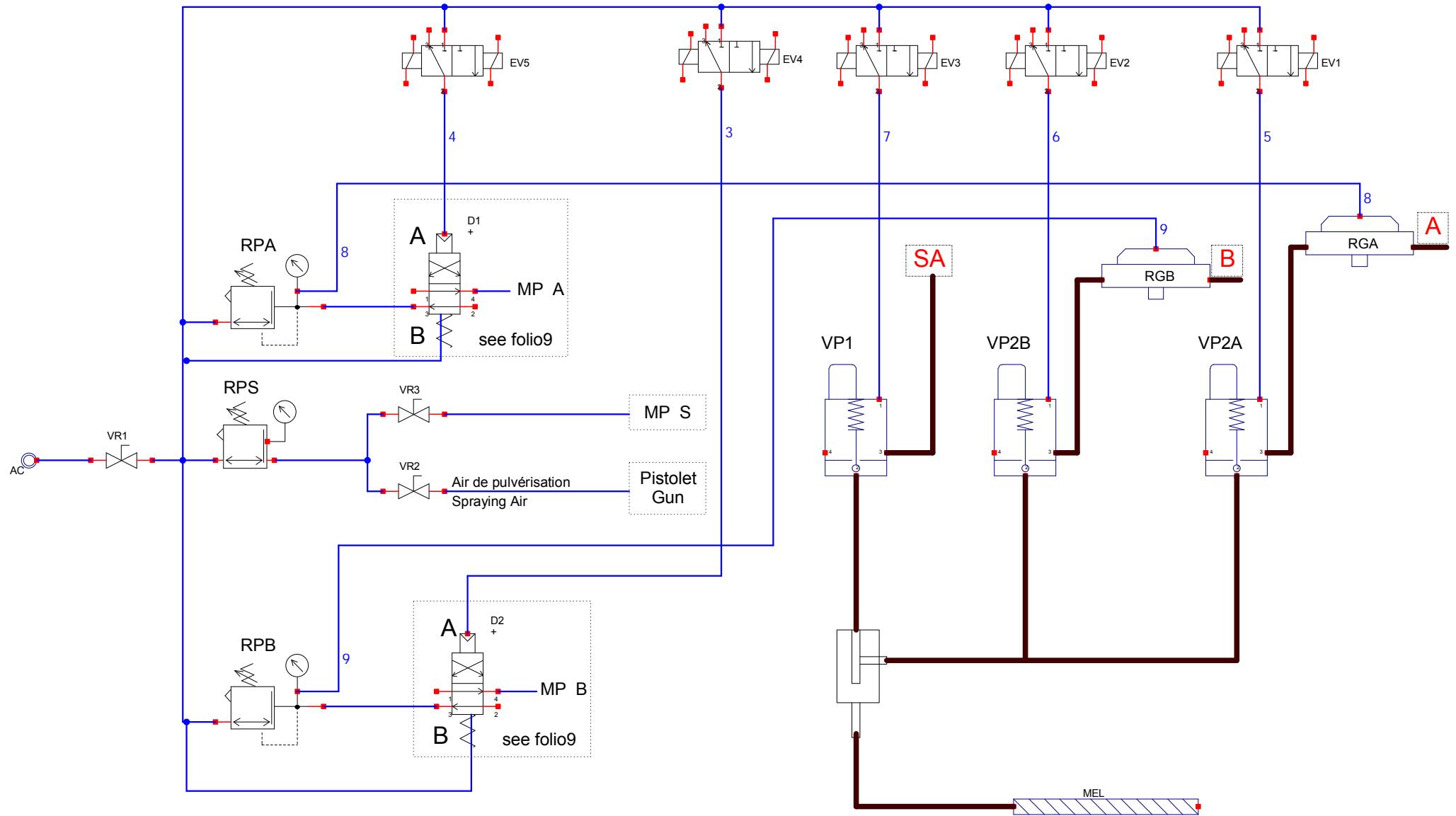

Pneumatique Airspray

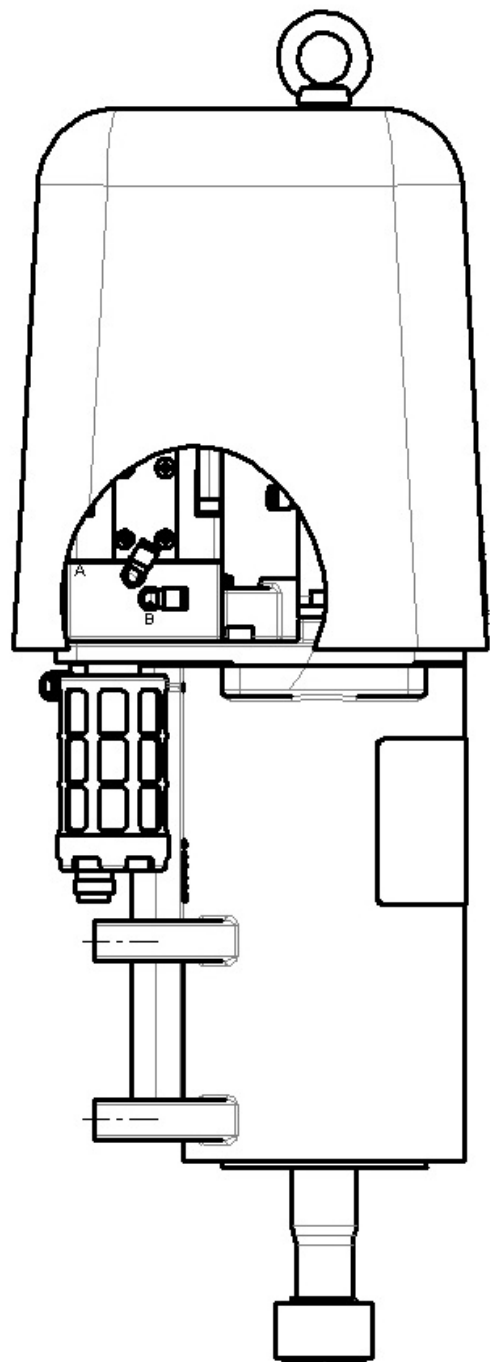

Pneumatique Airspray