



From February 1st, 2017 SAMES Technologies SAS becomes SAMES KREMLIN SAS
A partir du 1/02/17, SAMES Technologies SAS devient SAMES KREMLIN SAS

SAMES  **KREMLIN**



User manual

2K Metering Gear Pumps 0.3 - 0.6 - 1.2 - 2.4 - 6 and 10 cc

FRANCE

SAS SAMES Technologies. 13 Chemin de Malacher 38243 Meylan Cedex
Tel. 33 (0)4 76 41 60 60 - Fax. 33 (0)4 76 41 60 90 - www.sames.com

USA

Exel North America . 45001 5 Mile Road, Plymouth, Michigan, 48 170
Tel. (734) 979-0100 - Fax. (734) 927-0064 - www.sames.com

All communication or reproduction of this document, in any form whatsoever and all use or communication of its contents are forbidden without express written authorisation from SAMES Technologies.

The descriptions and characteristics mentioned in this document are subject to change without prior notice.

© SAMES Technologies 2010



WARNING : SAS Sames Technologies is registered with the Ministry of Labour as a training institution.

Throughout the year, our company offers training courses in the operation and maintenance of your equipment.

A catalogue is available on request. Choose from a wide range of courses to acquire the skills or knowledge that is required to match your production requirements and objectives.

Our training courses can be delivered at your site or in the training centre at our Meylan head office.

Training department:

Tel. 33 (0)4 76 41 60 04

E-mail: formation-client@sames.com

SAS Sames Technologies operating manuals are written in French and translated into English, German, Spanish, Italian and Portuguese.

The French version is deemed the official text and Sames will not be liable for the translations into other languages.

2K Metering Gear Pumps 0.3 - 0.6 - 1.2 - 2.4 - 6 and 10 cc

1. Health and Safety Instructions - - - - -	4
1.1. <i>Marking</i>	4
1.2. <i>Simplified analysis of the potential sources of ignition according to Standard EN 13463-1</i>	4
1.3. <i>Precautions for Use</i>	5
1.4. <i>Warnings</i>	5
1.5. <i>Insulation or Grounding</i>	6
2. Description - - - - -	7
3. Characteristics - - - - -	7
3.1. <i>General Characteristics</i>	7
3.2. <i>Dimensions</i>	8
3.2.1. <i>Pumps 0.3 and 0.6cc</i>	8
3.2.2. <i>Pumps from 1.2 to 10 cc</i>	9
4. Installation - - - - -	10
4.1. <i>General Information</i>	10
4.2. <i>Installation</i>	10
5. Start-up - - - - -	10
6. Maintenance- - - - -	11
6.1. <i>Tools</i>	11
6.2. <i>Preliminary Procedures</i>	11
6.3. <i>Pump Disassembly Procedure</i>	12
6.4. <i>Pump Reassembly Procedure</i>	16
6.5. <i>Breaking in the new pump</i>	22
7. Cleaning- - - - -	22
8. Troubleshooting - - - - -	23
9. Spare parts- - - - -	24
9.1. <i>2K Pumps</i>	24
9.2. <i>Maintenance kits for 2K pumps 0.3 cc and 0.6 cc</i>	25
9.3. <i>Maintenance kits for 2K pumps from 1.2cc to 10 cc</i>	26
9.4. <i>Connecting Flanges</i>	27

1. Health and Safety Instructions

1.1. Marking

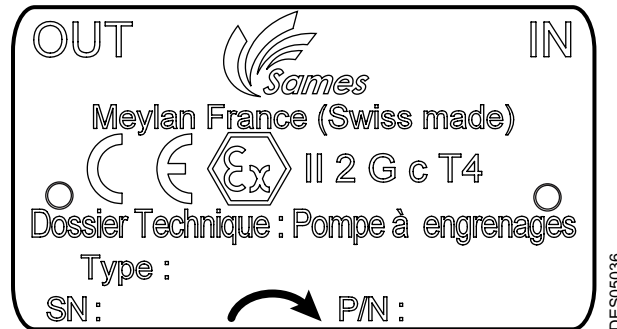

Type of the pump: 0,3 2K ADLC, 0,6 2K ADLC, 1,2 2K ADLC, 2,4 2K ADLC, 6 2K ADLC, 10 2K ADLC.

Example:

- Pump 6 cc: 6 2K ADLC P/N: 270000070

Remark: The arrow shows the direction of the pump.

1.2. Simplified analysis of the potential sources of ignition according to Standard EN 13463-1

Risk of ignition		Action applied to prevent anu ignition source to become effective
Potential source of ignition	Description / Main cause (What are the conditions engendering the ignition risk?)	Description of the applied action
Hot surface	Warm-up of the exterior surface of the pump due to a temperature of the metered fluid or to mechanical frictions or to an excessive speed.	Test to define the maximum temperature of surface
Spark of a mechanical origin	Friction of the gears and axes	Rotation speed is lower than 1m/s, (see § 3.1 page 7).
Electrostatic discharge	Incorrect grounding	Electrostaic discharge is impossible because all the parts of the pump are metallic and are connected between them, (see § 1.5 page 6)
Electrostatic discharge	Insulated pump	For an electrostatic installation, respect the rules: see § 1.5 page 6 .

1.3. Precautions for Use

This document contains information that all operators should be aware of and understand before using this material. This information highlights situations that could result in serious damage and indicates the precautions that should be taken to avoid them. The equipment must only be used by personnel trained by SAMES Technologies.

1.4. Warnings



WARNING : Safety may be jeopardized if this equipment is not operated, disassembled and reassembled in compliance with the instructions given in this manual and in any European Standard or national safety regulations in force.



WARNING : Equipment performance is only guaranteed if original spare parts distributed by SAMES Technologies are used.

Pump assemblies must be kept clean so that it is possible to detect any leaks and their severity.

Electrostatic spraying equipment must be serviced regularly in accordance with the information and instructions given by SAMES Technologies. The pump specifications must be observed carefully.

Cleaning operations must be carried out either in authorised areas equipped with a mechanical ventilation system, or using cleaning liquids with a flash point at least 5 °C higher than room temperature.

The operator must use the protections adapted for the eyes and the skin when the proportioned product presents dangers.

After having carried out repairs, adjustments or cleaning with polluting products, a particular care will be taken to the ecological elimination of waste.

It is strictly forbidden to any operator to interfere on equipment under operation.



WARNING : Please rinse thoroughly with the proper rinsing solution before each time the pump is taken apart and make sure that no pressure positive or negative remains.

Any modification of the pump being able to decrease the operating safety is prohibited.

The pump must be used in a surrounding area clear and clean.

Only metal containers can be used for cleaning liquids and they must have a reliable ground connection

The storage of the pumps or its components must be done in a dry room and safe from dust.

Before the installation of the pump, it is important to store it, as a preliminary, at the temperature to which the pump will be used in order to avoid any risk of seizing.

1.5. Insulation or Grounding

Use of these pumps with conductive products must comply with the rules concerning electrical insulation and enclosure-access reserved for this material. The possibility of the access to the enclosure must be checked to the switch-off of the high voltage in order to avoid any risk of electric shocks to the people. In all cases, the connection equipment must comply with the characteristics relative to the transport of pressurised liquid products up to 50 bar.

Pumping of conductive products and presence of **HV**:

- The configuration of the installation will be established by SAMES specialists.
- Any modification without consultation will result in the invalidity of the certificate of conformity.

Pumping of insulating products with or without the presence of **HV**:

- It is necessary to connect the pump to the ground with the connection screw located on the pump.

2. Description

This pump is designed especially for the metering of paints and products non-charged (Viscosity of 20 to 200 mPas).

All parts in contact with the paint are coated with ADLC.

The normal life under optimal parameters is about 2 years at a rate of 5 days per week and 8 hours per day. This value is given as an indication because it can change according to the metered product. Products with high viscosity will not be metered in the same way as products with low viscosity.

Product input and output are located on the pump body. The product to be metered is guided from the opening to the gears. The set of teeth fills up and drives the product to the exit. The set of teeth empties when the gear turns and pushes the product through the output opening by decompression.

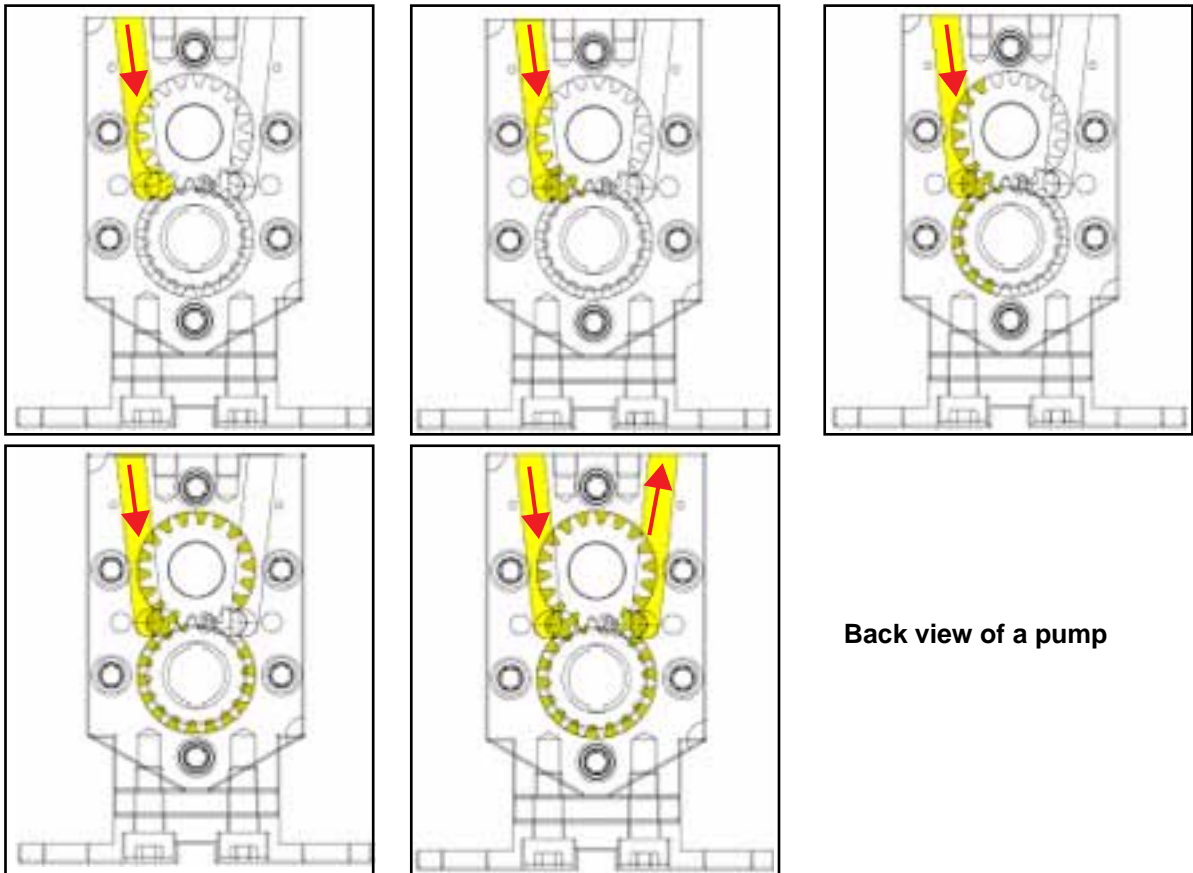

Back view of a pump

3. Characteristics

3.1. General Characteristics

- Pressures
 - optimal: 3 to 7 bars short 15 bars.
 - ΔP limit : 2 bars
 ΔP : output pressure - input pressure.
Higher ΔP increases the wear of the pump and decreases the accuracy of the metering.
- Rotation speed. : from 10 rpm to 120 rpm depending on the product (best results obtained between 30 and 80 rpm).

- Rinsing: Maximum 40 rpm, by pass open.
- Temperature of the metered fluid : 100°C max. for an ambient temperature between -20°C and 40°C.
- Dosage accuracy.
The accuracy of the dosage of a new pump is between $\pm 2\%$ within the following operation conditions:
 - Rotation speed between 30 and 80 rpm.
 - Rinsing oil viscosity of 25s DIN 4
 - Delta P ± 2 bar between input and output.

3.2. Dimensions

3.2.1. Pumps 0.3 and 0.6cc

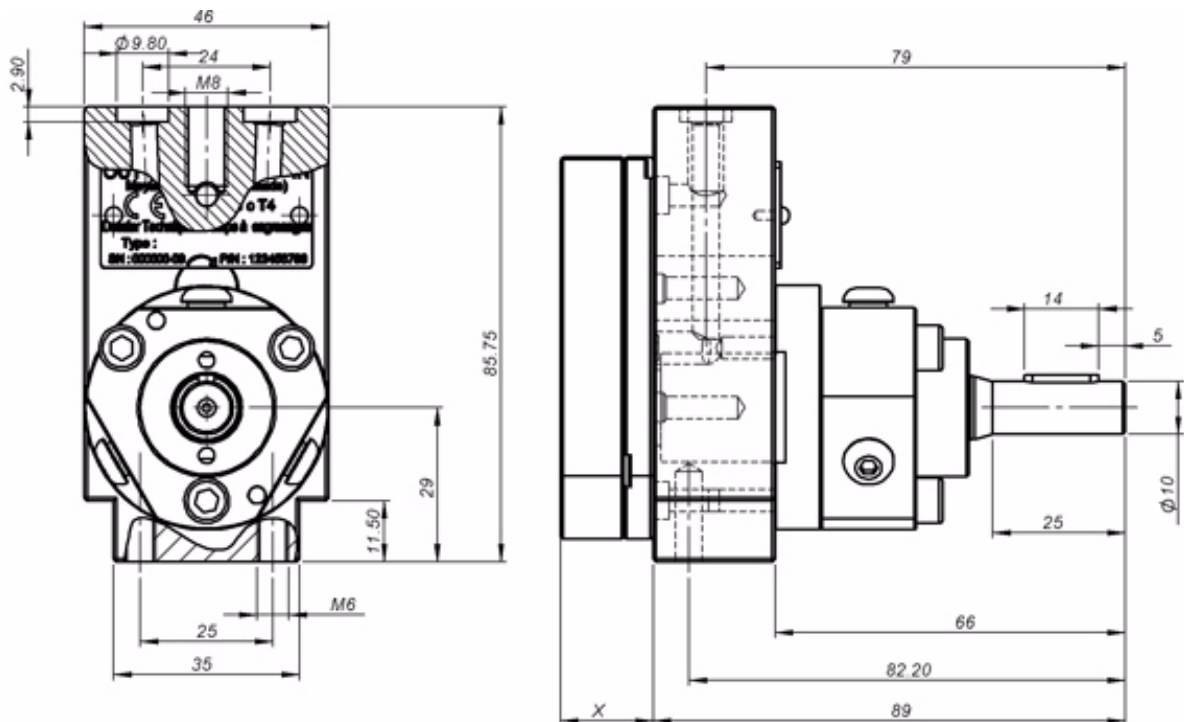

Dimensions are in mm.

Size	0.3 cc	0.6 cc
X (mm)	41.2	45.4
Weight	1.33 Kg	1.39 Kg

3.2.2. Pumps from 1.2 to 10 cc

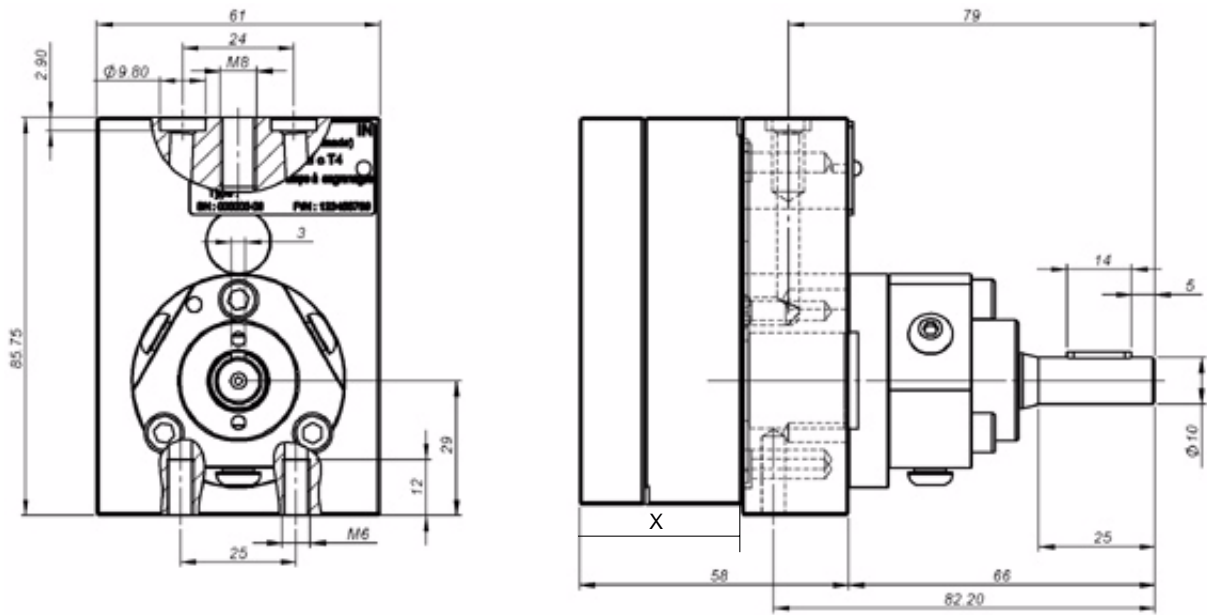

Dimensions are in mm.

Size	1.2 cc	2.4 cc	6 cc	10 cc
X (mm)	41.2	45.4	58	10
Weight	1.91 Kg	2.1 Kg	2.52 Kg	3.03 Kg

4. Installation

4.1. General Information

It is advised to clean the pump before its assembly. The inlets / outlets must be free from any impurities which could block the openings. Observe the direction of the rotation as well as the inlets/ outlets indicated on the pump. Turn manually the axis of the pump of some turns in order to check the rotation.



WARNING : Turning the axle of the pump in the bad direction can cause damage and destroy the pump. The direction of rotation of the pump is defined by positioning the drive-shaft in the direction of the observer.

It is also advised **NOT** to run the pump dry.

4.2. Installation

Elements linked to pump operation:

- The pump must be correctly installed on its stand. A perfect alignment between the pump shaft and the drive shaft must be respected. A minimum distance of 2 mm between the tip of drive shaft and the pump should be kept and the two should never touch. A radial pressure on the drive shaft can damage the pump.
- For leak proof connections, use rigid seals in PTFE.
- Check the hoses before and after the pump. In case of impurities at the entrance of the pump or if the product to be metered is not perfectly clean, a filter must be installed.
- The pump must not be in contact with any other element of the installation and adequate ventilation must be maintained around the pump.

5. Start-up

When starting the pump, the good sealing of the friction plates will be automatically verified. If the product leaks between the plates, the tension of the screws must be checked. ([see § 6.4 page 16](#)). If the leak persists, take the pump apart. After a good cleaning of the different parts and a careful check of the surfaces of the friction plates and of the mechanical seal, reassemble the pump ([see § 6.4 page 16](#)). A perfect seal is possible only if the surfaces are dry and perfectly clean.

The pump is shipped with a liquid barrier which does not require any maintenance.

Make sure that the rotation direction of the pump is correct and inputs/outputs are connected according to the rotation direction.

6. Maintenance



WARNING : The metering pump is designed to run in a continuous manner, but can also be used intermittently. During relatively short off periods, no particular maintenance or repair is necessary. The bearings are lubricated by the product metered and therefore it is advised **NOT** to run the pump dry.

6.1. Tools

- 3/4/5mm hex socket wrench (Dynamometric 8 to 10 Nm).
- 4 mm hex socket wrench.
- Plastic mallet.
- Screwdrivers (Nr 2 and 4).
- Indelebile marker.
- Cleaning paper.
- 1 sheet of paper of glass 1600.
- 1 fine abrasive stone (800 -1000).
- Solvent or hardener compatible with the product in the pump.
- 1 brush (hard) for the \varnothing 5mm grooves.
- Protective gear (according to the recommendations given by the manufacturer of the product to be metered).
- Special tool set for sealing device (P/N 270000089)



6.2. Preliminary Procedures

Before dismantling the pump, the following operations must be carried out:

- 1 Carry out a rinsing cycle with the suitable solvent, ensure that there are no input and output pressures and complete the cycle by prolonged blowing (**4 to 5 seconds**),
- 2 Lock the air and fluid valves, then disconnect the product hoses from the pump after having marked their respective positions,

6.3. Pump Disassembly Procedure



WARNING : A preventive maintenance is advised after 1600 operating hours. All the elements of the pump must be handled with an extreme delicacy, any shock between the different components could harm the future correct operation of the pump.

Step 1

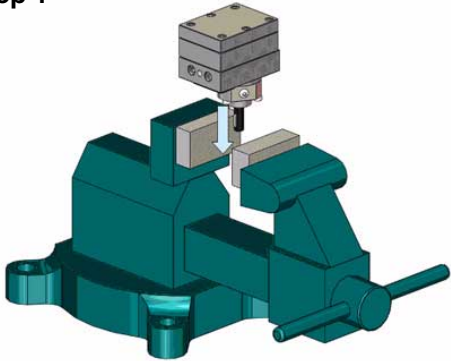

Place the pump in a vice.

Step 2

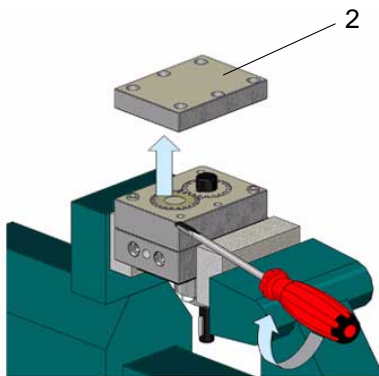

Unscrew the six securing screws of the rear plate (2) and separate it by carrying out a small rotation using a screwdriver.

Step 3

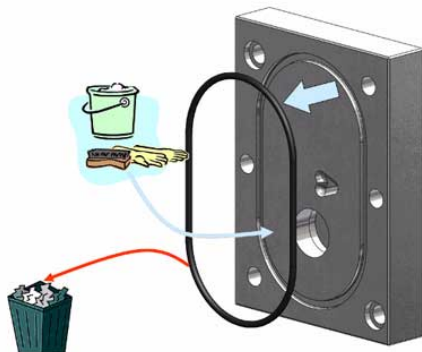

Remove the o-ring. Clean the rear plate using an appropriate solvent, pay a particular attention to the o-ring groove. The o-ring must be replaced at each reassembly.

Step 4

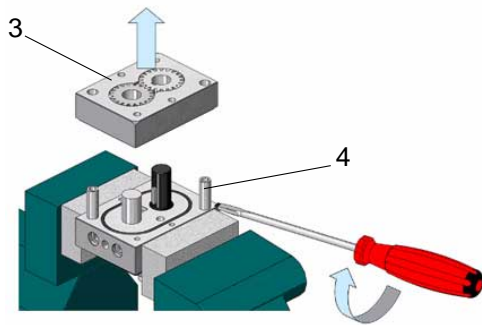

Remove the upper part (3) of the pump body.
Remove the two centering round key (4).

Step 5

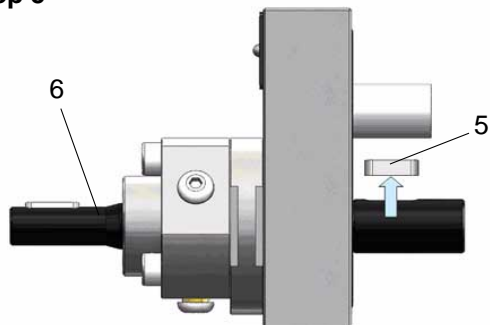

Withdraw the key or the pin (5) (according to the size of the pump) from the drive shaft (6).

Step 6

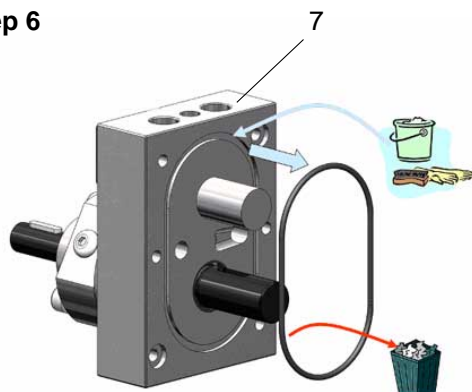

Remove the o-ring. Clean the body (7) using an appropriate solvent, pay a particular attention to the o-ring groove. The o-ring must be replaced at each reassembly.

Step 7

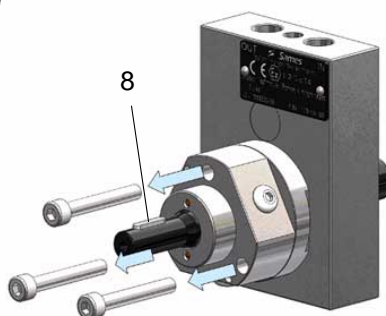

Unscrew the three screws of the sealing device and extract the key (8) from the drive-shaft.

Step 8

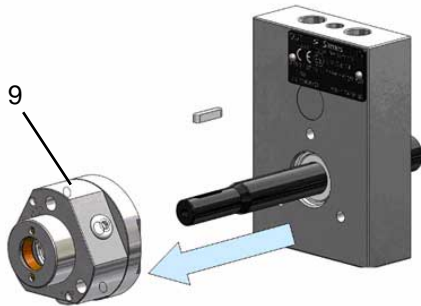

Remove the sealing system (9).

Step 9

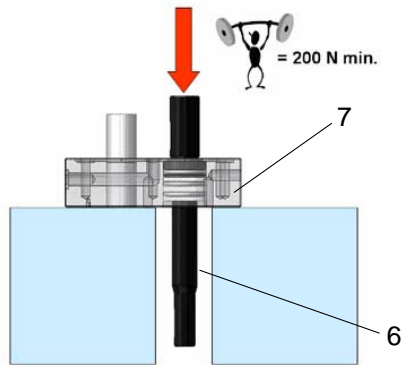

Extract the drive-shaft (6) from the body (7) using a mallet.

Step 10

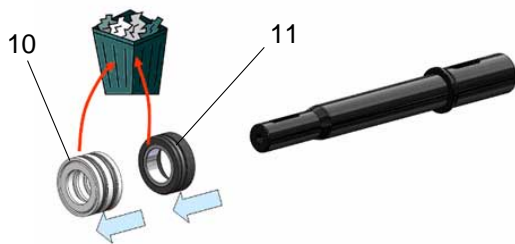

Remove the double lips seal assembly (10) then the bearing (11).

Step 11

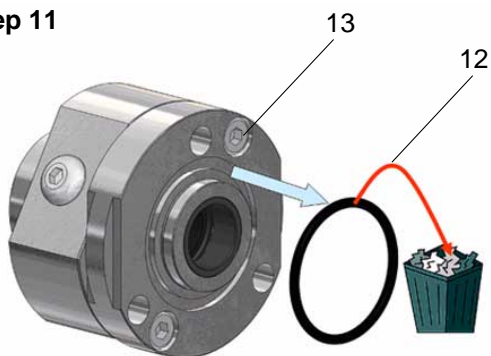

Remove the o-ring (12) and unscrew the two M 4x 20 screws (13).

Step 12

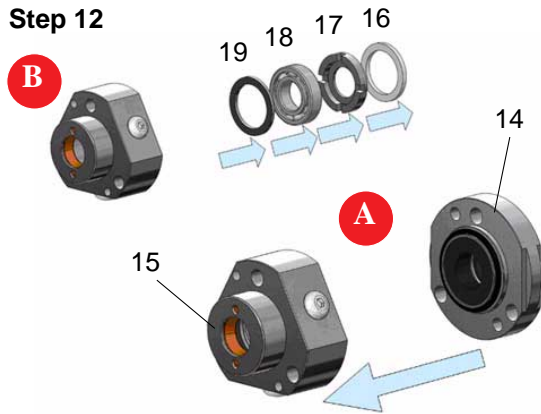

Step A: Separate the sealing unit body (14) from the bracket (15).

Step B: Remove the seal PTFE (16), the pressure ring (17), the ball bearing (18) and the intermediate ring (19).

Step 13

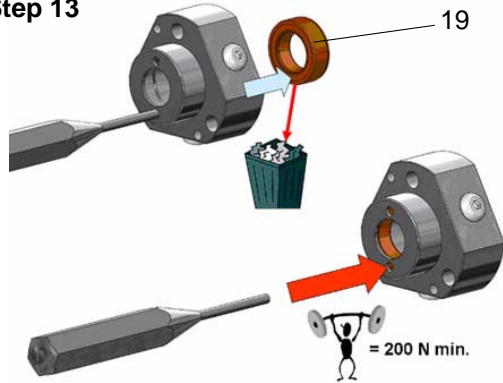

Using a pin-drift, extract the lip seal (19).

Step 14

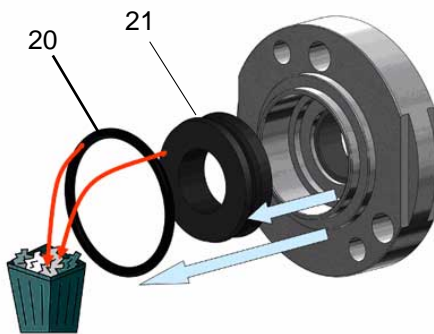

Remove the o-ring (20) and the lip seal PTFE du from the sealing unit body.

Step 15

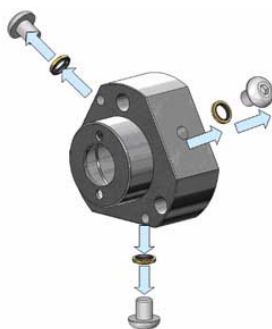

Unscrew the M5 x 6 screws.



WARNING : Disassembling may be assisted by tapping with a plastic mallet or by the introduction of blades made from synthetic material (nylon).

Use of materials that are harder than the pump material may result in permanent damage to the components.

6.4. Pump Reassembly Procedure

Step 1

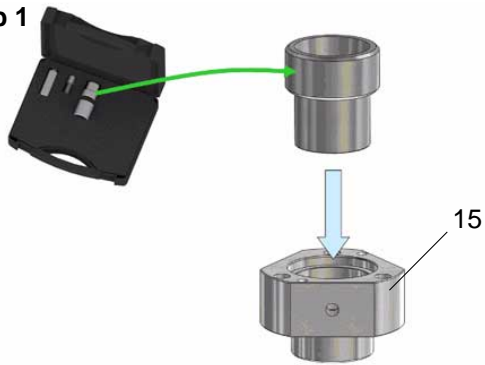

Put in place the tool on the bracket (15).

Step 2

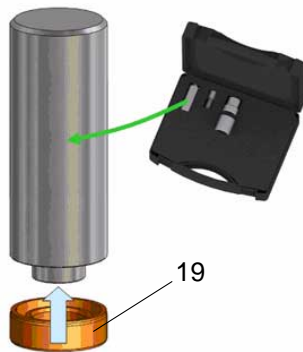

Install the lip seal (19) on the tool.

Step 3

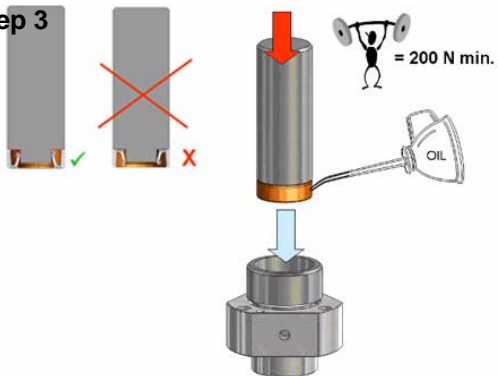

Place the lip seal on the bracket.

Step 4

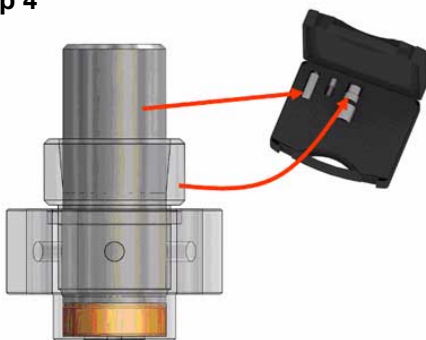

Remove the tools.

Step 5

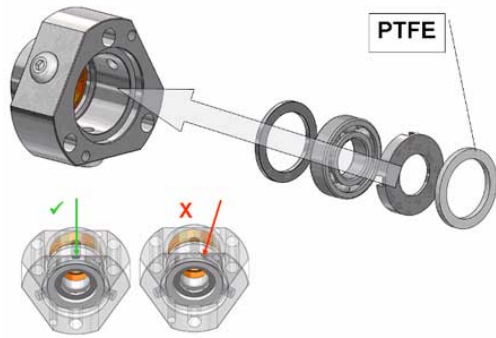

Check the conditions of the several components, replace if necessary then put back in place in the bracket.

Step 6

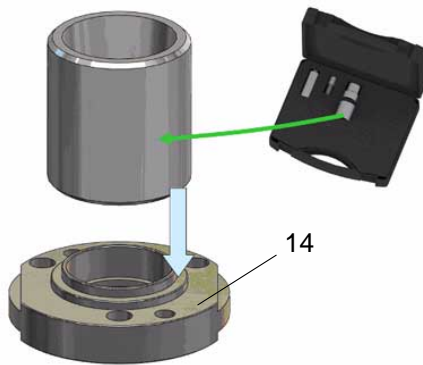

Place the tool on the sealing unit body (14).

Step 7



Place the lip seal on the tool.

Step 8

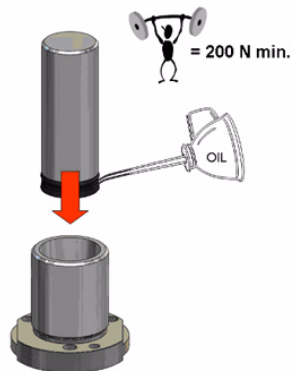

Place the lip seal in the sealing unit body.

Step 9

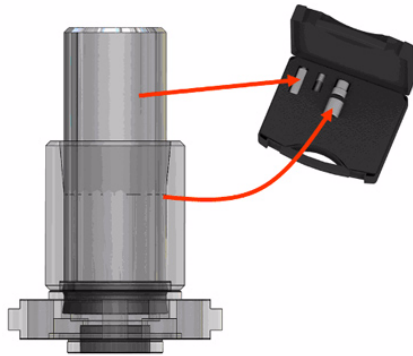

Remove the two tools.

Step 10

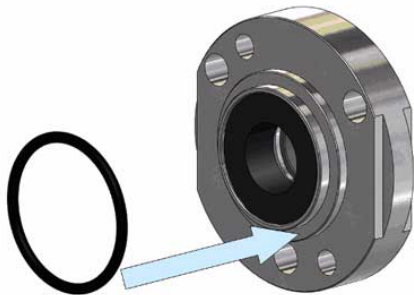

Install a new ring on the sealing unit body.

Step 11

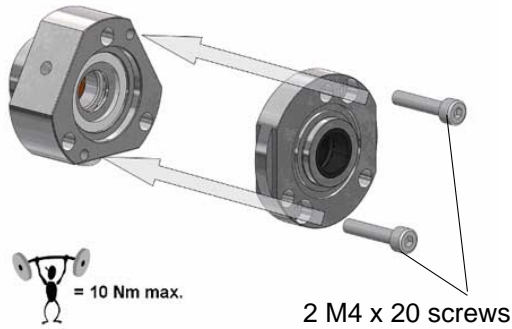

Screw the sealing unit body to the bracket.

Step 12

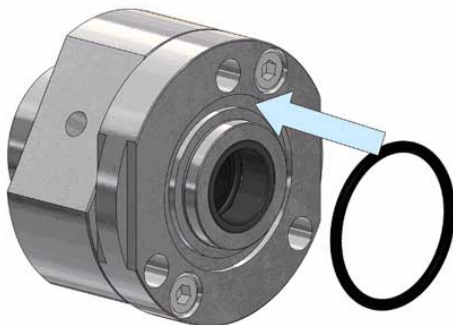

Place a new o-ring on the sealing system.

Step 13

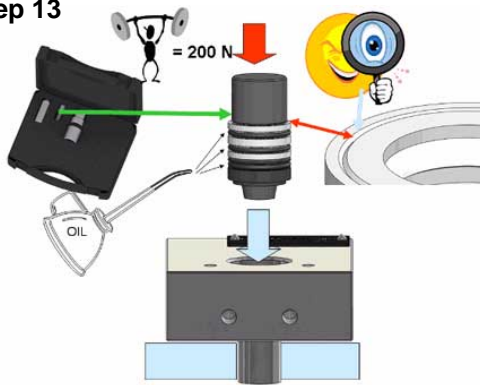

Install the bearing and the double lips seal in the body using the tool.

Step 14

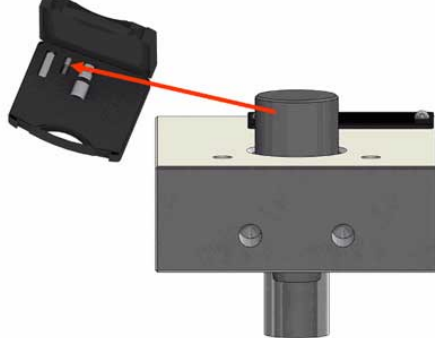

Remove the tool.

Step 15

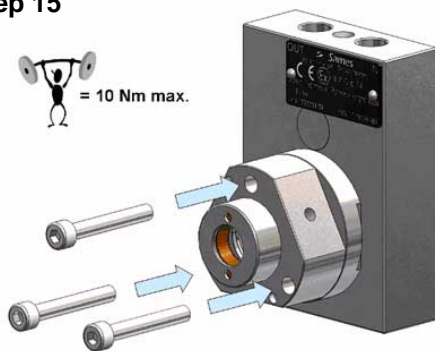

Screw the sealing system on the body (tightening torque: 10N.m).

Step 16

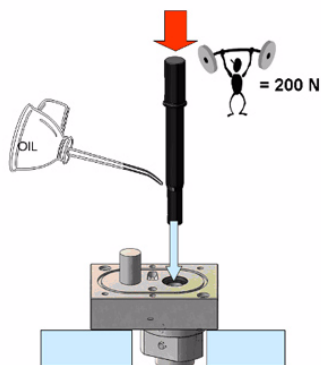

Insert the drive shaft in the body.

Step 17

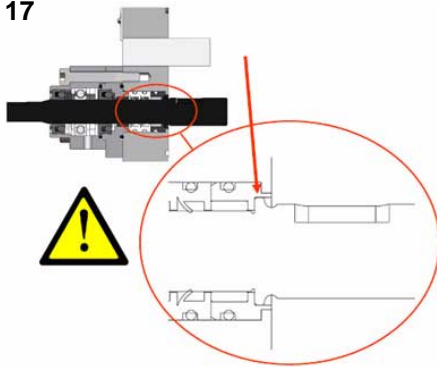

Respect the positioning of the drive shaft..

Step 18

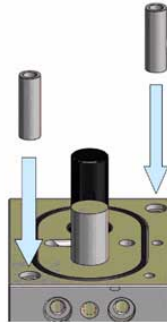

Install the centering pins on the body.

Step 19

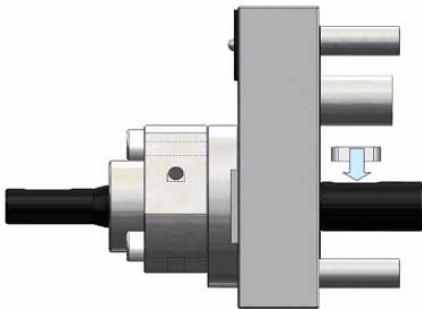

Place the key or the pin la clavette (according to the size of the pump) into the drive shaft.

Step 20

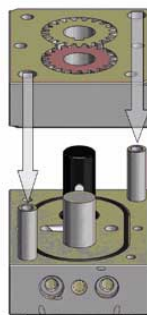

Place the upper part on the body.

Step 21



Place a new o-ring on the rear plate.

Step 22

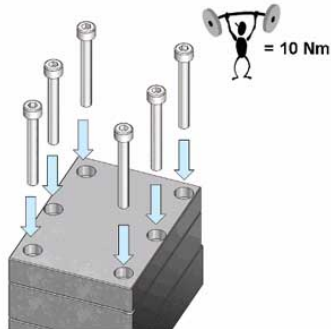

Secure the rear plate with the six screws (tightening torque: 10N.m).

Step 23

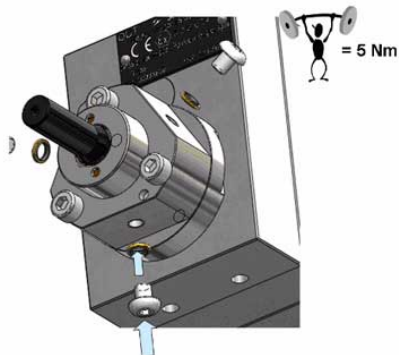

Put in place screws and washers, screw with a tightening torque 5N.m.

Step 24

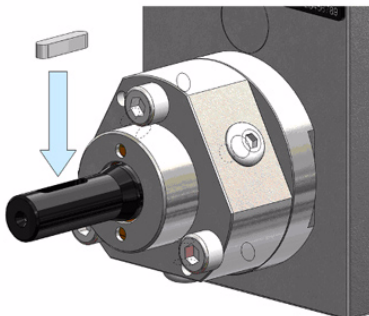

Insert the key into the drive shaft.

6.5. Breaking in the new pump

It is advised to break it in with the product to be metered.



WARNING : Rinsing a pump is a destructive operation for the pump when the recommendations are not followed to the point.

Before starting the pump for the first time, a rinsing is necessary. It must be done with the rinsing product recommended by the paint manufacturer.



WARNING : The rinsing must respect the following conditions:

- The rinsing time must be as short as possible because certain products of rinsing do not contain lubricant,
- the rotation speed must not exceed 40 rpm.

- Let the pump turn at a rotation speed of 20 to 30 rpm, with product in it, with an input pressure no to exceeding 3 bars and an outpressure of 0 bar, for one hour (if possible in close circuit).
- Following the same idea, increase the output pressure to 5 bars and so for 30 minutes.
- Then gradually, increase until the maximum pressure allowed is reached (15 bars), doing so 30 minutes at a time. During this time, it is possible to calibrate the pump in order to observe the output curb with the product running, and to compensate for any internal leakage of the pump by setting the rotation speed.

7. Cleaning



WARNING : The elements will be dipped in the solvent appropriate for the product metered. Using a nylon brush or flexible scraper, remove the traces of paint and seals remaining on the components. Dry with compressed air.

The element must never hit anything or be hit anything during this procedure. The parts will be put in the container with care.

For the cleaning operation, do not use metallic tools as screwdrivers, knives or chisels.

In order not to mix the parts from different pumps, only one pump will be cleaned in one container at a time.

The cleaning of a pump is often tedious.

This procedure is however, of prime importance in order to correctly analyse signs of wear and tear and to ensure perfect assembly, which in turn, ensures successful functioning of the pump.

8. Troubleshooting

Symptoms	Probable Causes	Remedies
Product leaking in the drive Shaft seal	Driving shaft worn Sealing unit worn out Incompatible products or pressures	Remove and check. Replace if necessary Contact Sames Technologies
Leakage in the plates area	Impurities between the plates Allowed pressures exceeded. Very thin liquid (leak by capillarity)	Take apart and clean the pump. Check the screw and tighten if necessary. Lower the pressures. Contact Sames Technologies
No precision in the metering.	Pump elements are worn out. Impurities in the Input/Output hoses. Feeding pressure too weak. Play not adapted to the product. Error during assembly	Take apart and check the pump elements as well as the I/O hoses. Check the I/O pressures. Check the viscosity of the product.
No output (the pump does not run)	The motor does not run. The coupling is broken or missing.	Check the motor and its electrical connection. Check the coupling and the keys.
No output (the pump runs)	The I/O are poorly connected or plugged. The pin driving the gears is broken. No product enters the pump.	Check the I/O connections. Check the feeding of the pump. Take apart the pump and check the pin and the gears.

9. Spare parts

9.1. 2K Pumps



Item	Part number	Description	Qty	Unit of sale	Maintenance level for spare parts (*)
	270000071	2K Pump - 0.3 cc	1	1	3
	270000072	2K Pump - 0.6 cc	1	1	3
	270000068	2K Pump - 1.2 cc	1	1	3
	270000069	2K Pump - 2.4 cc	1	1	3
	270000070	2K Pump - 6 cc	1	1	3
	270000067	2K Pump - 10 cc	1	1	3

(*)

Level 1: Standard preventive maintenance

Level 2: Corrective maintenance

Level 3: Exceptional maintenance

9.2. Maintenance kits for 2K pumps 0.3 cc and 0.6 cc

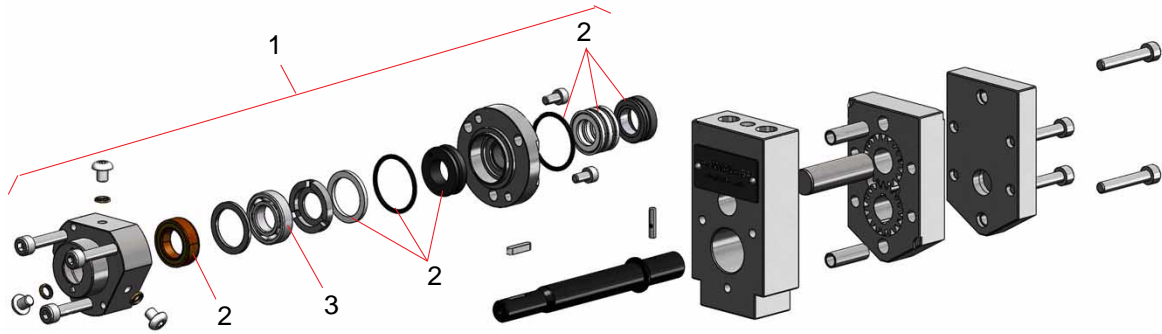

Item	Part number	Description	Qty	Unit of sale	Maintenance level for spare parts (*)
1	270000091	Complete sealing unit	1	1	2
2	270000093	Seal kit for sealing system included	1	1	1
		Bearing + axial thrust	1	-	-
		Double lips seal assembly	1	-	-
		O-ring 23.52 x 1.78	2	-	-
		Lip seal PTFE	1	-	-
		Seal PTFE	1	-	-
		Lip seal viton	1	-	-
3	270000092	Ball bearing	1	1	2

(*)

Level 1: Standard preventive maintenance

Level 2: Corrective maintenance

Level 3: Exceptional maintenance

9.3. Maintenance kits for 2K pumps from 1.2cc to 10 cc

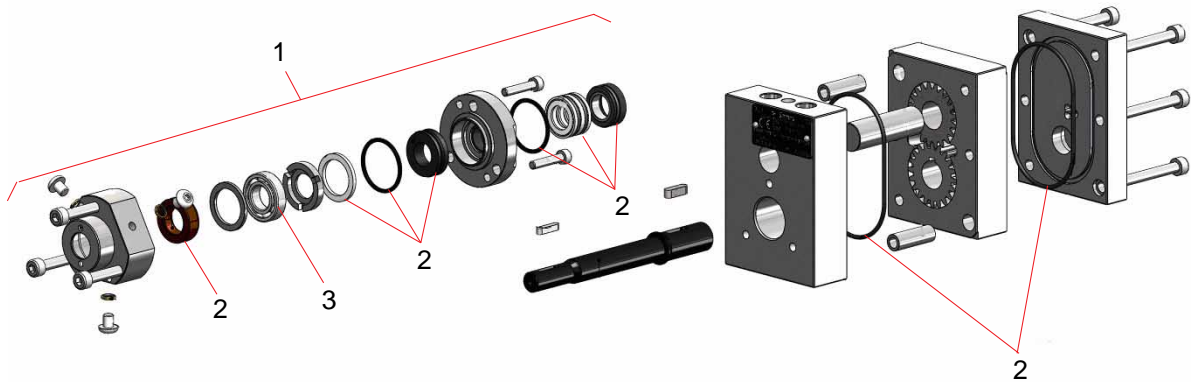

Item	Part number	Description	Qty	Unit of sale	Maintenance level for spare parts (*)
1	270000091	Complete sealing unit	1	1	2
2	270000090	Seal kit for sealing system included	1	1	1
		O-ring - viton 56.87 x 1.78	2	-	-
		Bearing + axial thrust	1	-	-
		Double lips seal assembly	1	-	-
		O-ring 23.52 x 1.78	2	-	-
		Lip seal PTFE	1	-	-
		Seal PTFE	1	-	-
		Lip seal viton	1	-	-
3	270000092	Ball bearing	1	1	2

(*)

Level 1: Standard preventive maintenance

Level 2: Corrective maintenance

Level 3: Exceptional maintenance

9.4. Connecting Flanges

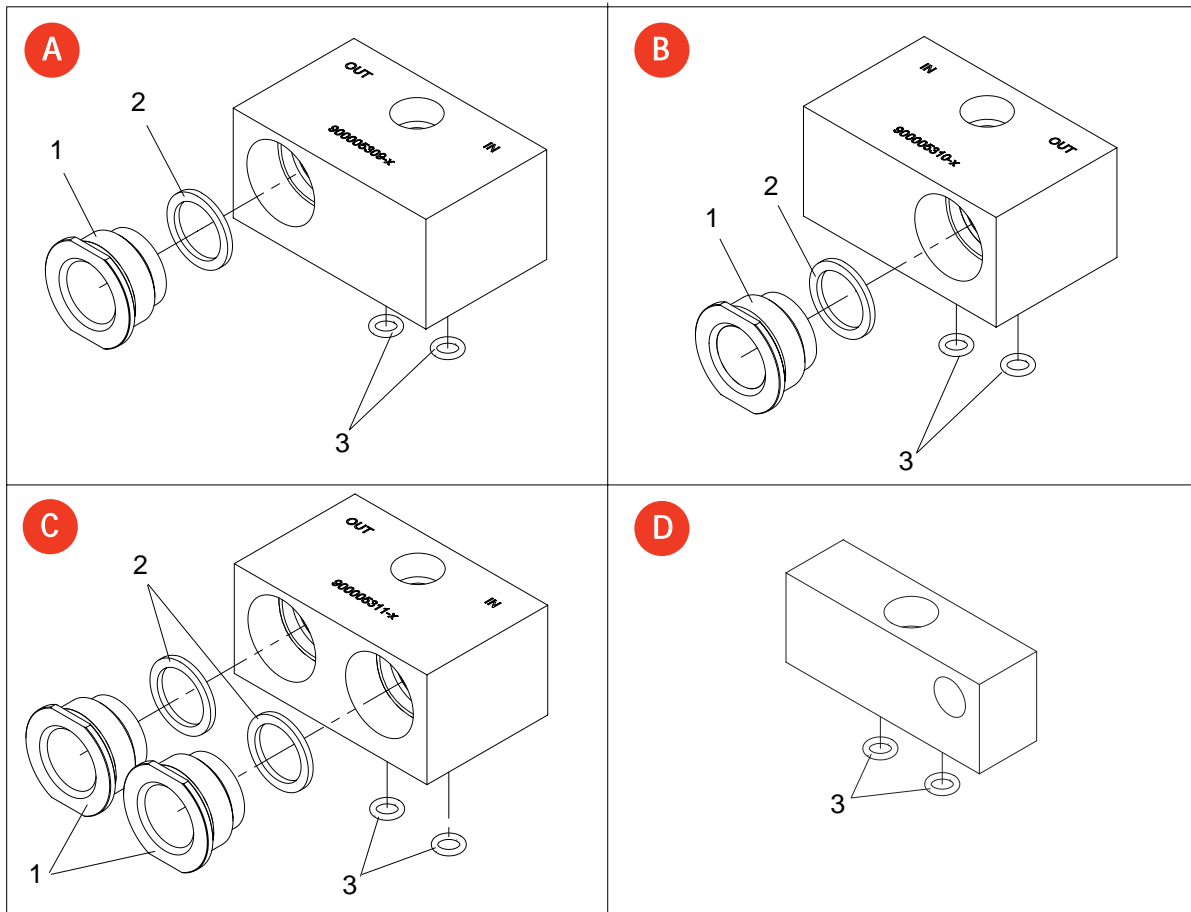

DES03623

Item	Part number	Description	Qty	Unit of sale	Maintenance level for spare parts (*)
A	910007407	1 Pressure switch flange	Option	1	-
1	270000023	Tightening adapter	1	1	-
2	270000024	O-ring - PTFE	1	1	1
3	J3TTCN118	O-ring - white PTFE	2	1	1
B	910007408	1 Pressure switch reverse flange	Option	1	-
1	270000023	Tightening adapter	1	1	-
2	270000024	O-ring - PTFE	1	1	1
3	J3TTCN118	O-ring - white PTFE	2	1	1
C	910007409	2 Pressure switch flange	Option	1	-
1	270000023	Tightening adapter	2	1	-
2	270000024	O-ring - PTFE	2	1	1
3	J3TTCN118	O-ring - white PTFE	2	1	1
D	910008031	Fitting fixing flange	Option	1	-
3	J3TTCN118	O-ring - white PTFE	2	1	1

Remarks: Flanges are used to connect, according to the type, one or two pressure switches.

Item	Part number	Description	Qty	Unit of sale	Maintenance level for spare parts (*)
	22000068AT	Pressure switch (0 to 50 bar) (pump outlet)	-	1	3
	22000069AT	Pressure switch (0 to 16 bar) (pump inlet)	-	1	3
	900005312	Pressure switch plug	-	1	3

(*)

Level 1: Standard preventive maintenance

Level 2: Corrective maintenance

Level 3: Exceptional maintenance

Remarks: Connecting flanges are fitted to the pumps by a Chc M8x 40 screw (P/N X3AVSY287).

Remarks:

- 1 When a pressure switch is used, it is imperative beforehand to install a tightening adapter (P/N: 270000023) on the connecting flange.
- 2 Put in place the o-ring (P/N: 270000024) then the plug (P/N: 900005312), when a pressure switch exit is not used.