

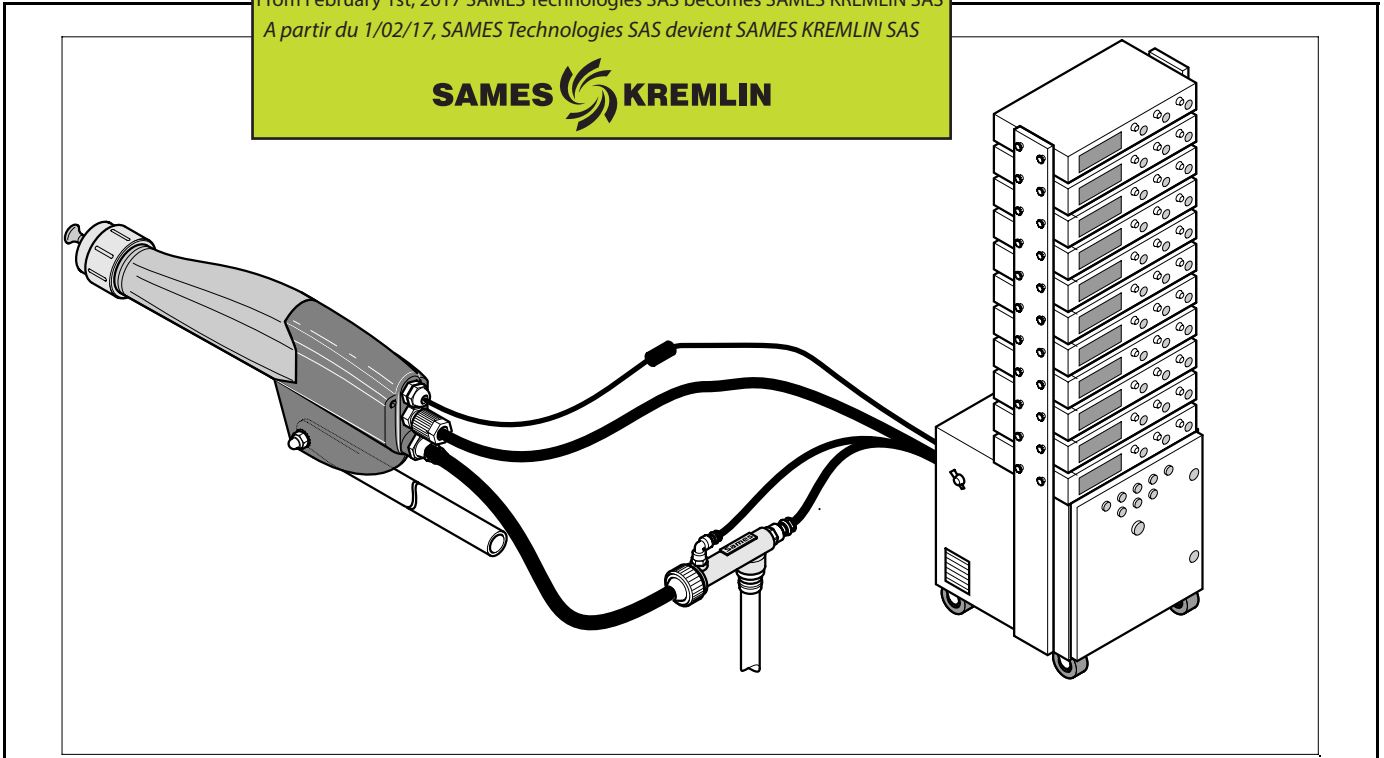

INSTRUCTIONS MANUAL

From February 1st, 2017 SAMES Technologies SAS becomes SAMES KREMLIN SAS
 A partir du 1/02/17, SAMES Technologies SAS devient SAMES KREMLIN SAS



SRV 416-US AUTOMATIC SPRAY APPLICATOR WITH CRN 456 CONTROL MODULE WITH GNM 100 (GB)

FM Approved

Nature of the modification: Added page 9 number of drawing indicated on the handle.

Established by: S LEFEBVRE	Checked by:	Checked by: DI GIOIA M.	Approved by: S LEFEBVRE
--------------------------------------	-------------	-----------------------------------	-----------------------------------

The information and characteristics given in this Manual are not contractual, and SAMES reserves the right to modify this equipment without notice.

CONTENTS	Page
1. DESCRIPTION	4
1.1. <i>GENERAL DESCRIPTION (REFER TO FIG. 1)</i>	4
1.2. <i>TECHNICAL CHARACTERISTICS</i>	4
1.3. <i>POWDER UNIT OPERATING PRINCIPLE</i>	7
2. INSTALLATION	9
2.1. <i>STANDARDS AND APPROVAL</i>	9
2.2. <i>SAFETY RULES</i>	9
2.3. <i>INSTALLING THE EQUIPMENT</i>	9
3. COMMISSIONING	11
3.1. <i>PREPARING THE POWDER UNIT</i>	11
3.2. <i>OPERATING AND ADJUSTING</i>	13
4. MAINTENANCE	17
4.1. <i>PERIODIC MAINTENANCE AND VERIFICATIONS</i>	17
4.2. <i>DISASSEMBLY AND RE-ASSEMBLY (GENERAL)</i>	17
5. TROUBLESHOOTING	18
6. SPARE PARTS:	
AD01-01-B - CS 126 SUCTION PLUNGER - 759692	19
AD02-B - DISMANTLING AND REASSEMBLY OF THE CS 126 SUCTION PLUNGER	20
BJ04-03-B - SHORT NOZZLES (FLAT AND ROUND SPRAY)	21
BJ04-04-B - NOZZLES LENGTH 150 MM (FLAT AND ROUND SPRAY)	22
BJ04-05-B - NOZZLES LENGTH 250 MM (FLAT AND ROUND SPRAY)	23
BJ04-12-A — FLAT SPRAY NOZZLE BSR 205-P	24
BK01-03-B - SRV 416 AUTOMATIC SPRAY APPLICATOR - 1509013	25
BK01-04-C - SRV 416 AUTOMATIC SPRAY APPLICATOR - 1509013	26
BK02-01-A - REPLACING THE POWDER DUCT	27
BK05-A - REPLACING THE LOW VOLTAGE CABLE (CABLE KIT)	28
CN01-03-A - GNM 100 (110 V) - 1504741 LOW VOLTAGE GENERATOR	29
CN03-A - CONNECTING THE SRV 416 ON THE GNM 100 LOW VOLTAGE GENERATOR	30
CP01-01-A - CRN 456 CONTROL MODULE	31
CP01-04-B - CRN 456 - 110 V CONTROL MODULE - 1503099	32

1. DESCRIPTION

1.1.GENERAL DESCRIPTION (REFER TO FIG. 1)

The automatic powder unit contains the following items (for an **SRV 416** automatic spray applicator):

- * An **SRV 416** powder automatic spray applicator [A] able to be equipped with a round or flat spray nozzle [B] mounted on its support [C].
- * **CRN 456** electro-pneumatic control module [D], equipped with the **GNM 100** controller [E], mounted on a **SAMES** modular panel [F] (not included in document).
- * **CS 126** suction plunger [G] or another feeding device.
- * An air supply hose [H], a powder hose [I] and an electric cable [J] with a connector "MINEX" [K].

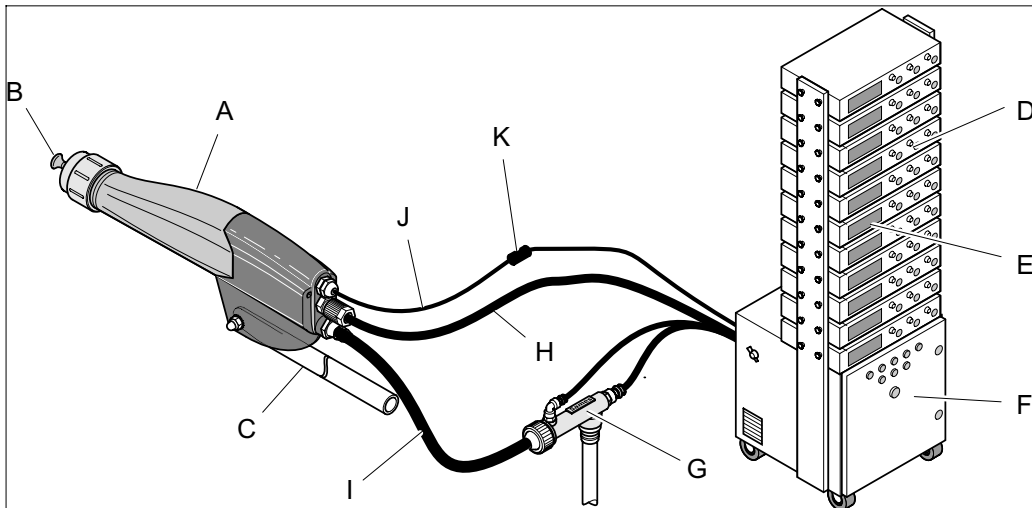

Figure n° 1

1.2. TECHNICAL CHARACTERISTICS

1.2.1. CRN 456 ELECTROPNEUMATIC CONTROL MODULE

Description:

The **CRN 456** control module, which includes a **GNM 100** Low voltage generator, takes the form of a 19 inch long rack with a height of 2 U and a depth of 270 mm.

This rack is designed to be mounted horizontally on a **SAMES** modular panel (not included in this document). The pneumatic adjustments can be reached only from the front panel of the control module. The control module can be controlled either remotely or directly from the front panel of the control module. A contact indicating an "electrical fault" is available and warns the user that the **GNM 100** low voltage generator has tripped (refer to section 3.2.7.6).

Electrical characteristics of GNM 100 :

Connection of the electro-pneumatic control module to the electrical network:

- * Input voltage..... 110 V 20 V.
- * Frequency..... 50 / 60 Hz.
- * Consumed power..... 50 VA.

Current output by the GNM 100:

- * Maximum output voltage.....60 VAC.
- * Maximum output current..... 1.1 A rms.
- * Frequency.....from 16 to 30 kHz.

Current output by SRV 416 automatic spray applicator :

- * Polarity negative.
- * Voltage..... from 0 to 85 kV.
- * Current..... from 0 to 80 A.

The electrical characteristic of **SRV 416** automatic spray applicator is of the "rectangular" type, which maintains a constant voltage regardless of the value of the current consumed, provided that it remains below the maximum output current.

Pneumatic characteristics:

- * Max. working temperature for the equipment..... 104 jF (40 jC)
- * Max. inlet pressure 150 psi g (10 bars).

- * Min. inlet pressure for a flow of 10.54 SCFM (17 m³/h) 60 psi g (4 bars).
 - * Max. consumption of compressed air 10.54 SCFM (17 m³/h).
 - * Characteristics of supply compressed air according to NF standard **ISO 8573-1**:
 - maximum dew point at 90 psi g (6 bars)..... class 4 or + 37 °F (3 °C),
 - maximum size grading of solid pollutants..... class 3 or 5 microns,
 - maximum oil concentration class 1 or 0.01 mg/ m³ (*),
 - maximum concentration of solid pollutants class 3 or 5 mg/m³ (*).
- (*): values given for a temperature of 68 °F (20 °C) at atmospheric pressure.

1.2.2.GENERAL CHARACTERISTICS OF THE SRV 416 AUTOMATIC POWDER FLOW

- * Length approx. 380 mm.
- * Weight approx. 600 g.
- * Air connector : - on rear body 3/8" BSP Male,
- air fitting 6 mm inner dia., 8 mm outer diam.
- * Powder supply fitting..... maximum inner dia. - 11 mm (**642396**),
maximum inner dia. - 13 mm (**1400552**).

1.2.3.SRV 416 AUTOMATIC SPRAY APPLICATOR POWDER FLOWS

The following chart gives (**as a guideline**) powder flows (*) with a **SRV 416** spray applicator fed with a **CS 126** plunger (versus inner diameter feeding powder hose and versus the length of the feeding powder hose. For a plunger air feeding pressure (or "injection" pressure) of 45 psi g, measured close to the plunger.

In. dia. of the feeding powder hose (mm)	0.433 in. (11 mm)				1/2 in. (12.8 mm)				
	13	20	26	33	13	20	26	33	40
Length of the feeding powder hose (ft)									
Powder flow (lb/h)	66	57	51	39	78	72	64	58	54

- * : these powder flows are obtained under the following conditions :
- with an EPOXY/POLYESTER powder of 35 μm median diameter,
 - with new plunger parts,
 - with no "dilution" air.

1.2.4.POWDER FLOW CHARACTERISTICS (see figure n ;5)

The powder flow delivered by the spray applicator depends on the following main parameters:

- the "injection" air pressure (set using the pressure reducing valve [**D1**]),
- the "dilution" air pressure (set using the pressure reducing valve [**D2**]),
- the length and internal diameter of the powder hose,
- the wear of the "venturi" ejector,
- the wear of the air injector,
- the level of the powder in the hopper,
- the configuration of the powder hose (avoid loops and bends, and ensure that the robot motions only cause limited position changes of the powder hose).

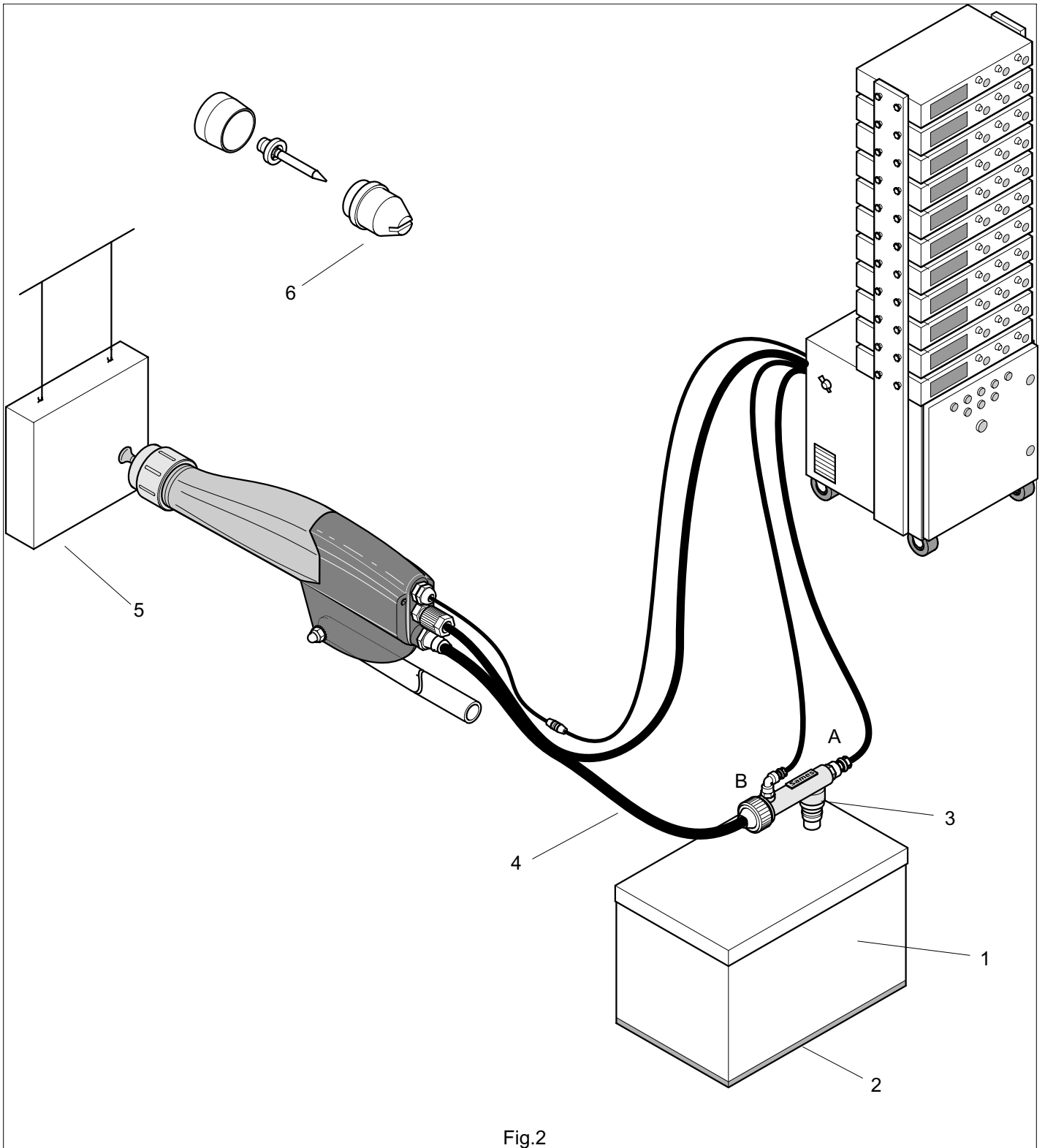

Fig.2

1.3. POWDER UNIT OPERATING PRINCIPLE

(refer to **fig. 2**)

Powder units fitted with an **SRV 416** automatic spray applicator are designed for automatic powder installations.

The powder paint is normally contained in a powder distribution hopper [1], where it is fluidized by means of an ascending air flow coming from the porous bottom [2] of the hopper.

It is then conveyed via an air jet in the suction plunger [3] through to the spray applicator.

The suction plunger is a drive effect pump; a high speed air jet (supplied in [A]) - known as "injection" air - is used to drive pre-fluidized powder to the powder spray applicator via a hose [4] - known as the powder hose.

The static pressure of the powder spray leaving the suction plunger, which is around 20 to 250 mbar greater than atmospheric pressure, conveys the powder over a hose length which can reasonably reach 10 meters (for a hose with an internal diameter of 11 mm).

The sucked up (or rather "driven") powder flow depends on the difference in pressure between the inlet and the outlet of the suction plunger and increases as this difference decreases.

As a result, a short powder hose with a large cross-section will be able to convey a higher powder flow than a long hose with a small cross-section .

Likewise, a hopper filled with powder will yield a higher powder flow than a hopper which is practically empty (all else being equal).

In order to ensure regularity of small powder flows, additional air - known as "dilution" air - can be added to the suction plunger (in [B]).

The **SRV 416** automatic spray applicator is a device with a conventional "Corona" charge; an electrode [6] brought to a high negative potential is placed at the far end of the spray applicator.

The intense electric field surrounding the electrode enables the latter to ionize the air.

The ions emitted follow the electric field lines and thus move towards the part to be painted [5]; the powder is charged as it flows through the ionized electric field.

If the charged powder paint is to adhere to the part to be painted, the part must be conductive (or semi-conductive) and properly earthed (the electric resistance of the part with respect to earth must be less than 1 MΩ).

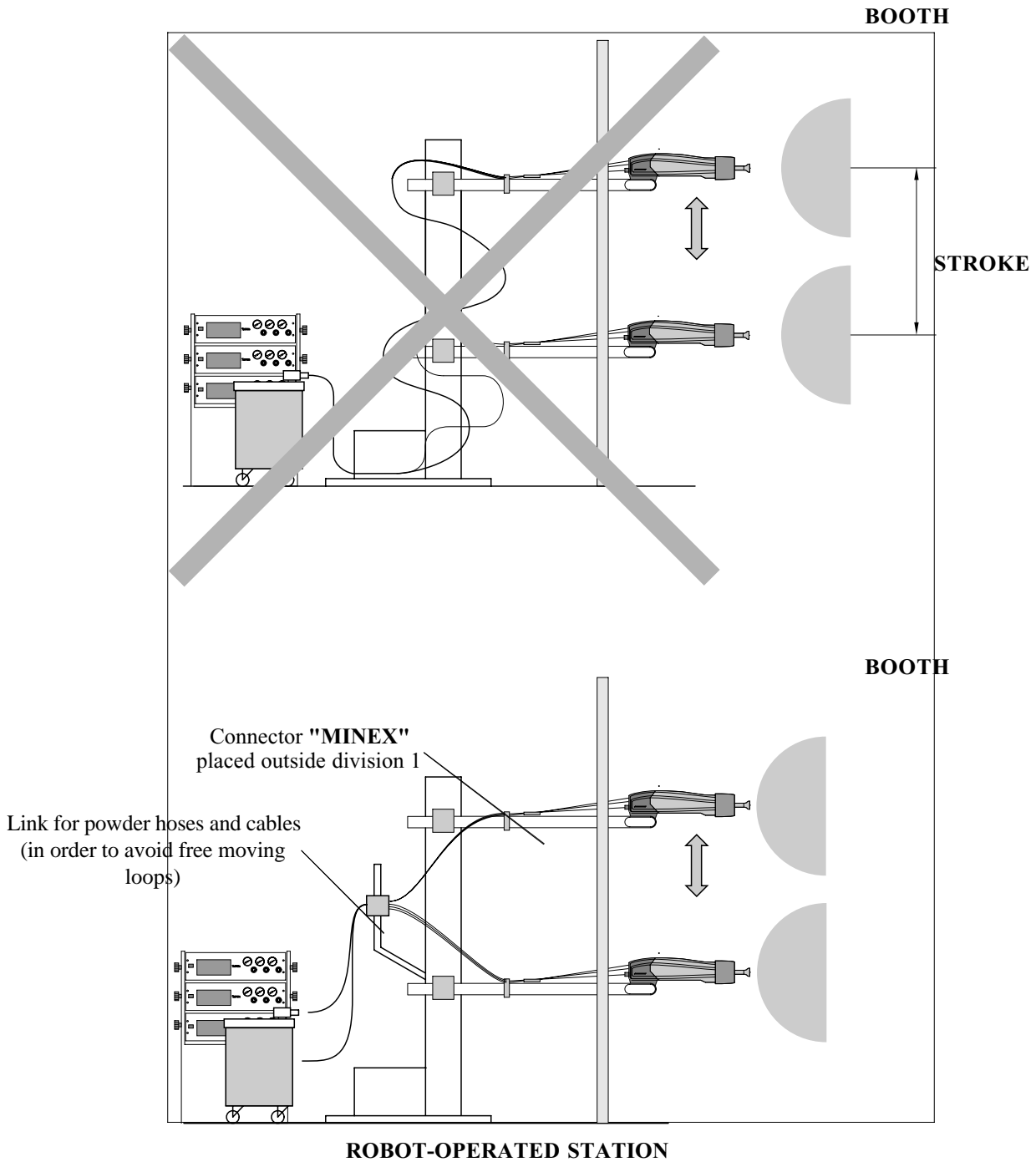

Fig. 3

2. INSTALLATION

2.1. STANDARDS AND APPROVAL

The Equipment **SRV 416** is approved by Factory Mutual (FM) only if it FM marked for the following configurations according to # 1303261. The engraving is located on the gun handle.

Low Voltage generator		Electropneumatic control module		Gun		Option	
Model/N	P/N	Model/N	P/N	Model/N	P/N	Model/N	P/N
GNM 100	1504741	CRN 456	1503099	SRV 416	1509013	Counter Electrode	1507442

2.2. SAFETY RULES

IMPORTANT NOTE: This automatic spray equipment is only for use with powder coating material

This equipment could be dangerous if not used according to the safety rules set out in this manual.

1. The electrical connector "MINEX" must always be placed outside the hazardous area (that means outside the division 1). A label on which is written the following sentence :

WARNING: DO NOT DISCONNECT THE CONNECTOR "MINEX" WHILE CIRCUIT IS LIVE.

must be put close to the connector.

2. The electro-pneumatic control module, including low voltage generator **GNM 100**, must always be installed in a "non-hazardous area".
3. The electrostatic spraying equipment must only be used by trained personnel fully aware of the following rules No. 4 to No. 8 :
4. Powder shall be sprayed in front of a ventilated station provided for this purpose. The ventilation extraction system and the powder application equipment shall be servo-controlled to each other so that spraying is only possible if the extraction ventilation is in operation.
5. All conducting structures such as floors, powder spraying station walls, ceilings, barriers, parts to be painted, powder distribution reservoirs, etc. placed inside or close to the working position, and the electro-pneumatic control module earthing terminal, shall be electrically connected to the electrical power supply protective earthing system.
6. Each part to be painted shall have a resistance to earth less than or equal to 1 MΩ.
7. The powder spraying equipment shall be maintained regularly in accordance with the manufacturer's instructions. All repairs shall be carried out respecting these instructions.
8. The high voltage power supply must be switched off before starting to clean the spray applicator or to do any other work within the spraying area, so that it is impossible to switch on again by pressing the spray applicator "trigger".

2.3. INSTALLING THE EQUIPMENT

The equipment must be installed in accordance with the safety rules laid down in paragraph 2.1.

The equipment must be installed so that the length of the powder hose does not exceed 8 to 10 meters.

The powder hose must be mounted so that its curvature is minimum and displacement of the spray applicator (if a robot is used) changes the position of the hose as little as possible (refer to **fig. 3**).

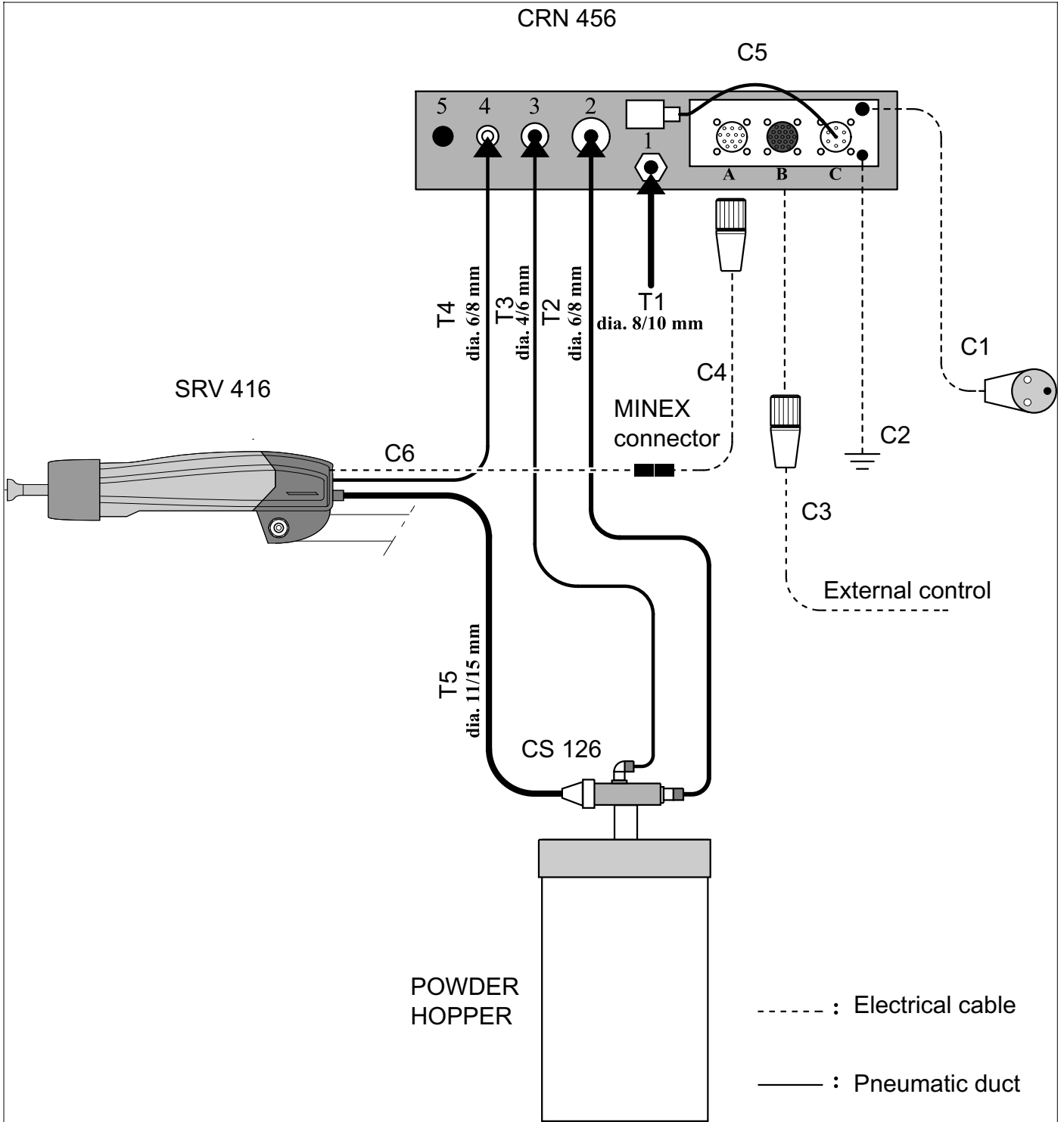

Fig. 4

3. COMMISSIONING

3.1. PREPARING THE POWDER UNIT

3.1.1. ASSEMBLING THE VARIOUS COMPONENTS

- * Mount the spray applicator on a support using a metal nut.
- * Mount the **CRN 456** control module on a **SAMES** modular panel.

3.1.2. CONNECTING THE COMPONENTS (REFER TO FIGURE N_i4)

- * Make sure that the seal is present on the output [5] of the **CRN 456** control module.

Connect the following items:

- * An air supply hose [T1] (\varnothing 8/10 mm) from the compressed air system to the input [1] of the control module.
- * The "injection" air hose [T2] (\varnothing 6/8 mm) from the **SRV 416** powder spray applicator to the **CRN 456** electro-pneumatic control module, output [2], to the **CS 126** suction plunger.
- * The "dilution" air hose [T3] (\varnothing 4/6 mm) from the **CRN 456** electro-pneumatic control module, output [3], to the **CS 126** suction plunger.
- * The "vortex" air hose [T4] (\varnothing 6/8 mm) from the output [4] of the control module to the **SRV 416** spray applicator.
- * The powder hose [T5] (\varnothing 11/15 mm) from the **SRV 416** powder spray applicator to the **CS 126** suction plunger (follow the recommendations of paragraph 2.2).
- * The socket [C1] of the **CRN 456** electro-pneumatic control module on the mains.
- * The earthing cable [C2] from the **CRN 456** electro-pneumatic control module to the earthing system protecting the electrical supply.
- * The socket of the external control cable [C3] onto the **CRN 456** electro-pneumatic control module, on plug **B**.
- * The extension cord [C4] onto the **CRN 456** electro-pneumatic control module, on plug **A**.
- * The "MINEX" plug of the **SRV 416** [C6] onto the "MINEX" plug of the extension cord [C4].
- * Check that the electro-valve is properly connected to the **CRN 456** electro-pneumatic control module via the cable [C5] on plug **C**.

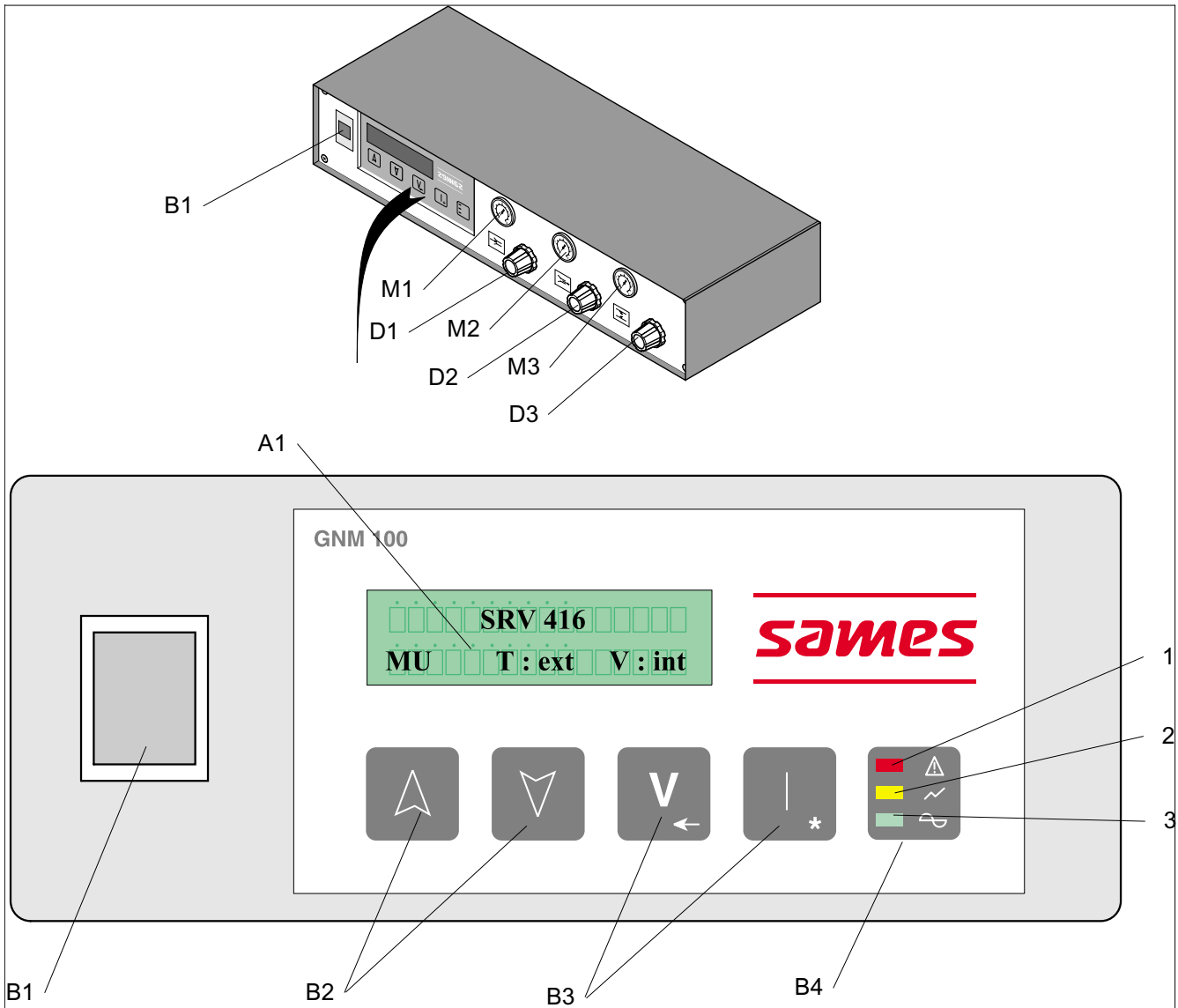

Ref.	Function
A1	Numerical display of current or voltage
B1	"On" switch
B2	Button for current or voltage adjustments
B3	Button for scrolling along the menus and for validating
B4 (1, 2 and 3)	Various luminous signals
D1	"Injection" air pressure plunger adjustment valve
D2	"Dilution" air pressure plunger adjustment valve
D3	"Vortex" air pressure adjustment valve for round spray nozzles
M1	Plunger "injection" air pressure control manometer
M2	Plunger "dilution" air pressure control manometer
M3	"Vortex" air pressure control manometer for round spray nozzles

Fig. 5

3.2. OPERATING AND ADJUSTING

(refer to **figure n 5**, and thoroughly read the recommendations in paragraph 2.1. before using the powder unit).

3.2.1. ADJUSTING THE ORIENTATION AND POSITION OF THE POWDER SPRAY APPLICATOR

Paragraph 3.1.1. explains how to adjust project position. The powder spray applicator must be positioned at a distance of between 150 mm and 300 mm from the part to be coated with powder.

3.2.2. FLUIDISING THE POWDER IN THE HOPPER

The "fluidizing" air pressure must be adjusted to the value that is just sufficient to ensure that the powder "boils" in the hopper.

3.2.3. AUTHORISATION OF COMPRESSED AIR SUPPLY AND OF HIGH VOLTAGE ELECTRICAL SUPPLY (FOR REMOTE CONTROL ONLY)

Several possibilities to activate the **GNM 100** are available; refer to the **GNM 100** user manual to use them. An example is given on plate **CN03** of chapter 6.

3.2.4. ADJUSTING THE POWDER FLOW

The powder flow is adjusted using the **CRN 456** electro-pneumatic module:

- * The pressure reducing valve [**D1**] adjusts the "injection" air pressure on which powder flow is directly dependent.
- * The pressure reducing valve [**D2**] adjusts the "dilution" air pressure. The "dilution" air must only be used for small powder flows in order to avoid bursts of powder. The powder flow supplied by the suction plunger varies according to several parameters (refer to paragraph 1.2.3).

3.2.5. ADJUSTING "VORTEX" AIR (WITH A ROUND SPRAY NOZZLE)

The pressure reducing valve [**D3**] adjusts the "vortex" air flow on the **SRV 416** automatic spray applicator equipped with a round spray nozzle.

It is vital to adjust the air flow in order to obtain the right jet width (too high a "vortex" air flow will wear out the nozzle before its time).

3.2.6. VOLTAGE AND CURRENT ADJUSTEMENTS

- * Approximate voltage and current settings as a function of the type of part to be coated with powder (**as a guideline**):

	Output voltage limitation (in kV)	Current limitation (in A)
- Heavy coating thickness (>°100° m).	60 to 85	10 to 50
- Coating on uncoated parts without recess and coating thickness less than 100 m.	70 to 85	60 to 80
- Parts with recesses.	50 to 85	10 to 50
- Powder coating on pre-coated parts.	50	5 to 20

- * The value of the voltage (or output current) may be displayed on the digital display unit [**A1**].
- * The voltage must be adjusted to a value of between 40 to 85 kV, depending on the powder flow, the part type and the powder thickness to be deposited on the part.

3.2.7. USING THE GNM°100 LOW VOLTAGE GENERATOR (refer to fig. 8)



3.2.7.1. Power supply voltage and connections

The low voltage generator **GNM 100** has already been adjusted when delivered according to the value of voltage indicated on the box.

Check that the low voltage generator earth terminal (located on the back of the generator) is properly connected to the electrical earth; plug the mains cable in.

Connect the **SRV 416** plug on the **GNM°100**.

3.2.7.2. Screen and keyboard presentation

The  and  arrows modify a set value or change a table.

Use the  key for scrolling down the menus.

Use the  key for scrolling up the menus or for erasing memory.

The green indicator (3) indicates presence of mains voltage, the orange indicator (2) shows the state of the trigger (pressed or released), and the red indicator (1), lights up to show that a fault is present.

3.2.7.3. Switching on

To switch the **GNM 100** on, press push button (B1). The green indicator (3) lights up.

- 1 - If the **SRV 416** is connected for the first time (or if another high voltage generator was connected at it last power on), the display is:

SRV 416?
OK = <--

Validate by pressing button .

- 2 - The display becomes:

Push button  for scrolling down the menu.

SRV 416
MU T : ext V : int

Meaning of the abbreviations:

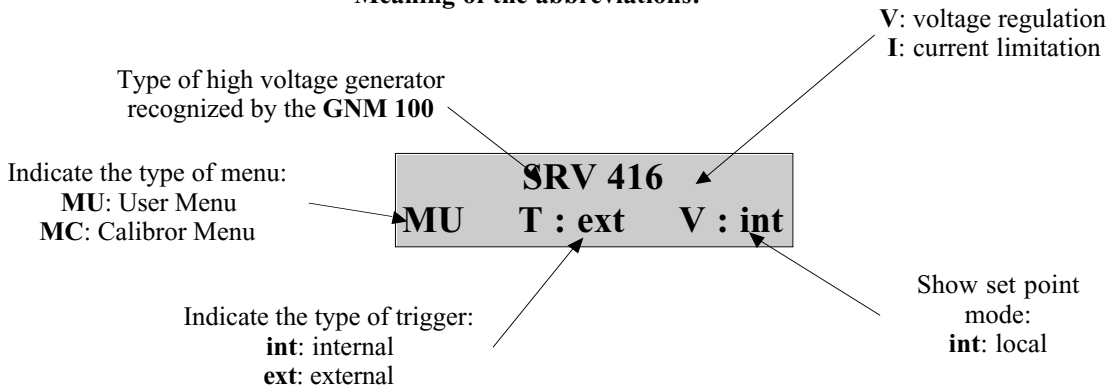

3.2.7.4. Adjustment procedure for the GNM°100 low voltage generator (see figure 5)

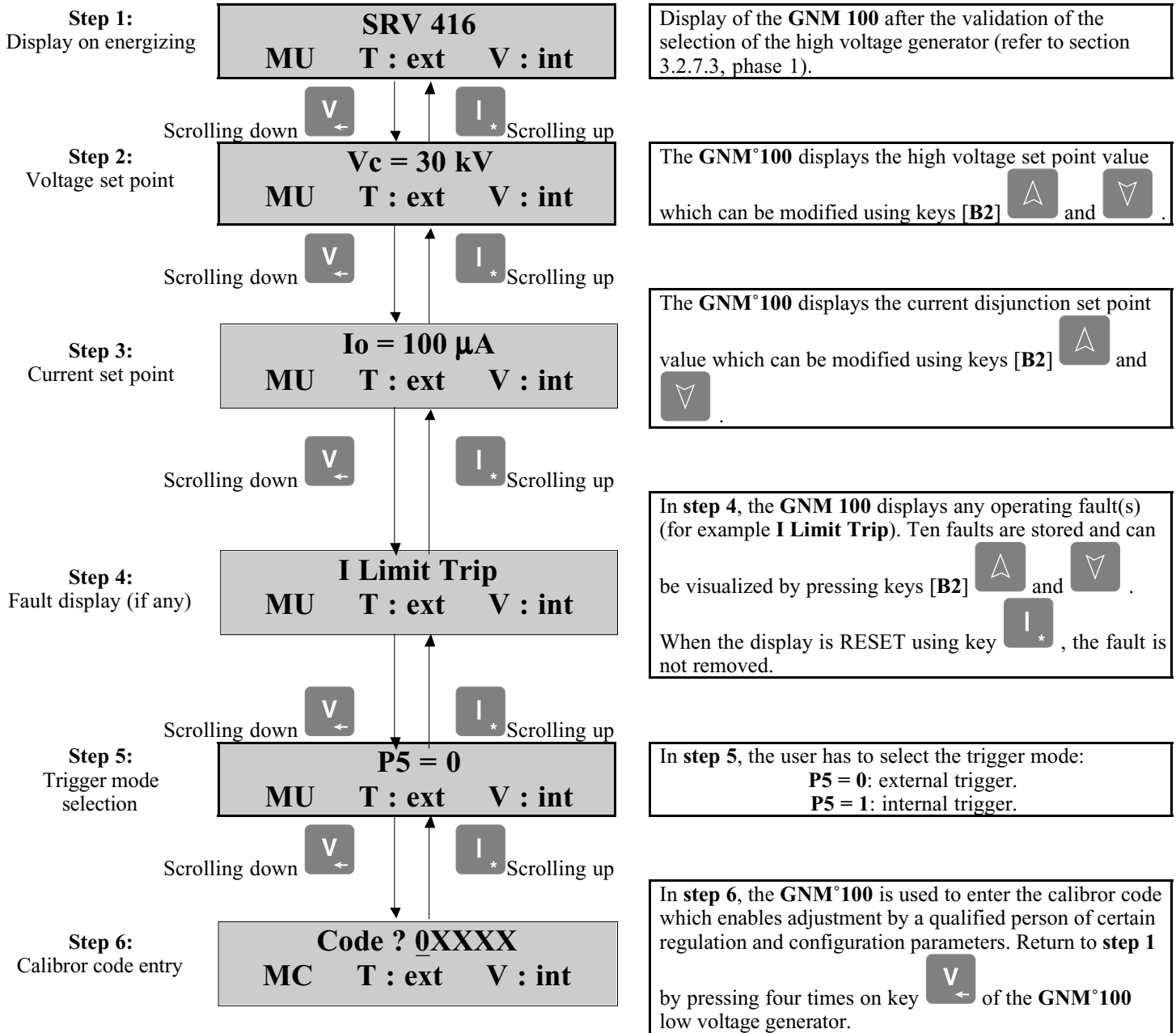

For further details on the GNM°100 low voltage generator, consult its user manual - RT 6128.

When the trigger is activated, the display becomes, for instance:

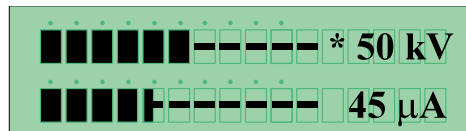

3.2.7.5. Set point change

Refer to /3.2.7.4.

With **SRV 416**, the layout of the **GNM°100** enables the following adjustments:

- the voltage set point "Vc", adjustable from 0 to 85 kV,
- the switch off current "Io", adjustable from 0 to 100 µA.

The following safety devices are available (refer to section 3.2.7.6):

- An overcurrent disjunction which appears when the measured current at the output of the **SRV°416** becomes higher than "Io". When it works, the current safety" switches off high voltage and displays the message "**I°Overflow Trip**".

Thus, it is necessary to adjust the voltage set point "Vc" in order to ensure that the output current of the **SRV°416** will never reach the "Io" value during the normal operation of the spray applicator.

3.2.7.6. Faults

The last fault is immediately displayed:

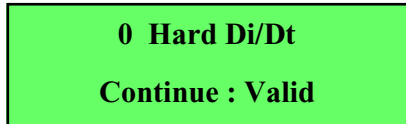

There are 2 different types of fault.

- The faults which turn the HV will need the resetting of the HV by triggering the HV OFF/ON.
- A major fault is flagged the same way. Resetting can only be done by switching the main power OFF/ON.

A. Fault screens

- Config. Trip fault configuration.
- V limit Trip fault voltage distinction (V>Vmax of given cascade).
- I limit Trip fault current distinction (I>Imax of given cascade).
-Set up mod Trip trigger and controller in calibration menu.
-Trigger Trip trigger on when controller powered.

B - Trip out/reset screens

- Fault tempeture temperature fault.
-Fault UP cascade not recognized.
-Fault CC short circuit LV output.
-Fault Reg. Freq. bad frequency regulation.
-Fault P bad PC board.
-Fault supply V internal DC power supply regulation fault.

The following message is displayed, for example:

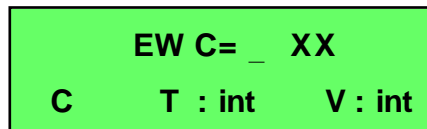

4. MAINTENANCE

4.1. PERIODIC MAINTENANCE AND VERIFICATIONS

IMPORTANT: All cleaning operations must be carried out only with compressed air, rag or eventually a brush.
Never use water or solvent to clean the equipment.
The use of a cleaning solvent even light (Viadyl type) leads to the destruction of the barrel.

Dirt and wear of the **SRV 416** equipment caused by the use of powder paint depends on the nature of the powder paint.

Thus, maintenance intervals shown below are for guidance only.

The user must build up his own maintenance program, as he gains experience in using the **SAMES** equipment.

We recommend that you start by using the following maintenance program:

MAINTENANCE FREQUENCY	ACTION
<ul style="list-style-type: none"> • Before starting the work. 	<ul style="list-style-type: none"> • Check that items 4, 5, 7 and 8 in section 2.2 are respected.
<ul style="list-style-type: none"> • Daily. 	<ul style="list-style-type: none"> • Remove the suction plunger from the hopper, then clean it using compressed air. • Check that there is no powder accumulated at the end of the intake. • Check the venturi outlet for hardened powder deposits. • Clean the powder feed pipe.
<ul style="list-style-type: none"> • Between 40 and 60 hours of work. 	<ul style="list-style-type: none"> • Clean the gun nozzle, leaving it to soak for several hours in methyl-isobutyl-cetone (MIBK). • For metallic powder use: disassembly the gun and blow compressed air in the handle and the gun. Refer to section BK02-01-A - REPLACING THE POWDER DUCT. <div style="border: 1px solid black; padding: 2px; margin: 5px 0;"> <p>WARNING: This solvent is toxic and inflammable.</p> </div> <ul style="list-style-type: none"> • Remove the suction plunger from the hopper, then clean it using compressed air. • Dismantle the venturi outlet and check for wear; if oval-shaped and/or grooved marks are apparent on the outlet, the injector and outlet should both be replaced. • If the inside diameter of the outlet is greater than 5.3 mm, replace the outlet.

4.2. DISASSEMBLY AND RE-ASSEMBLY (GENERAL)

The pneumatic fittings that need to be frequently disassembled and re-assembled are of the "fast connection/disconnection" type :

- * To fix a hose in position, simply push it as far down as possible into the fitting orifice.
- * To separate the hose from the pneumatic fitting, use the fingers to pull the ring encircling the hose towards the fitting and then take it out.

Disassembly and re-assembly of the complex assemblies is set out in detail in chapter.

5. TROUBLESHOOTING

SYMPTOM	PROBABLE CAUSE	REMEDY
* The powder does not come out of the spray gun.	* Spray gun badly installed.	* Check the installation and connections comply with the those described in chapters 2 and 3.
	* SRV 416 badly adjusted.	* Follow the instructions in section 3.2.
	* Insufficient air flow supplied by the compressed air network.	* Refer to section 1.2.2.
	* Powder feeding hose is blocked.	* Clean the powder feeding hose using compressed air.
	* Solenoid valve no longer works (characteristic noise when the "trigger" is pressed, is no longer heard). – Solenoid valve control is defective. – Solenoid valve is defective.	* Check the continuity. – Have the low voltage controller repaired by a SAMES Agent. – Replace the solenoid valve.
* Plunger was not correctly replaced after disassembly.	* Reinstall the plunger correctly (refer to plate AD01).	
* Powder does not stick to the part.	* Part is not properly earthed.	* Make sure that the electrical resistivity of the earthed parts is less than 1M Ω .
	* Ionizing electrode is covered in hardened powder.	* Switch off the HV power supply and then clean the electrode, checking that the output current is less than 30° A for nozzles with a flat spray.
	* Voltage is not high enough.	* Increase the voltage, taking care that he output current does not exceed 30° A for nozzles with a flat spray.
Current consumption is too high	* A conductor part is too near the spray gun electrode.	* Move the conductor part away from the spray gun electrode.
	* The power pipe is become conductor	* Clean or change the powder pipe.
	* The power gun is become conductor	* Disassembly the gun and clean using compressed air.
* No display on the GNM 100 or appearance of a fault on the GNM°100 display	* Fault detected by the GNM 100 or GNM 100 failure.	* Refer to section 3.3.6.

6. SPARE PARTS

AD01-01-B - CS 126 SUCTION PLUNGER - 759692

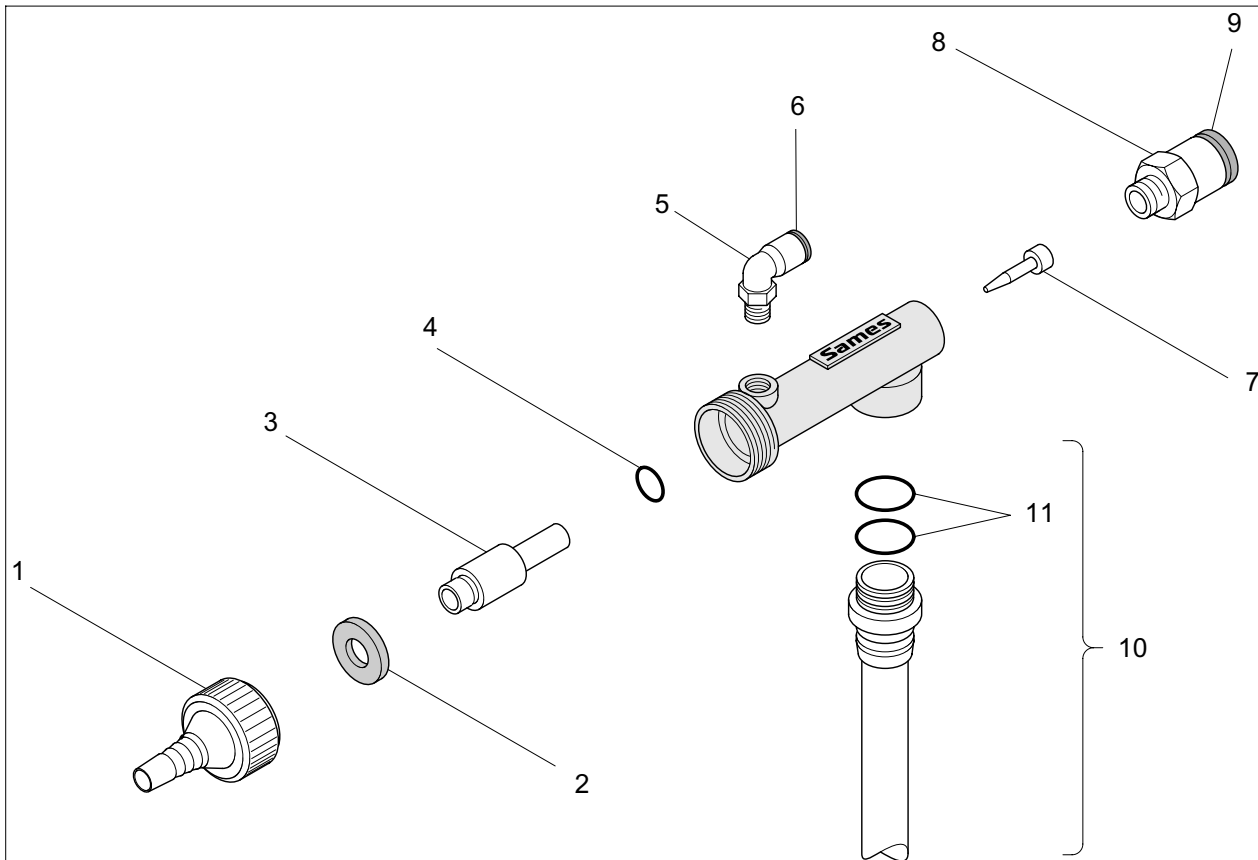

Item	Article code	Description	Qty	Sales unit
	759692	CS 126 SUCTION PLUNGER		1

	852196	CS 126 SUCTION PLUNGER WITHOUT TUBE		1
1	545192	Powder outlet end piece	1	1
2	444490	Porous ring	1	2
3	547880	"venturi" pump	1	10
4	J2CTPC139	11 x 1.5 O-ring	1	10
5	F6RLCS211	Dia. 6 mm - 1/4 " elbow fitting	1	1
6	F6RLZB402	Dia. 6 mm red ring	1	10
7	544808	Air injector	1	5
8	F6RLUS236	Dia. 8 mm - 1/4 " plug connector	1	1
9	F6RLZB406	Dia. 8 mm red ring	1	10

10	852197	CS 126 PLUNGER TUBE with O-rings (11)		1
11	J2CTPB253	20 x 2.5 O-ring	2	10

AD02-B - DISMANTLING AND REASSEMBLY OF THE CS 126 SUCTION PLUNGER

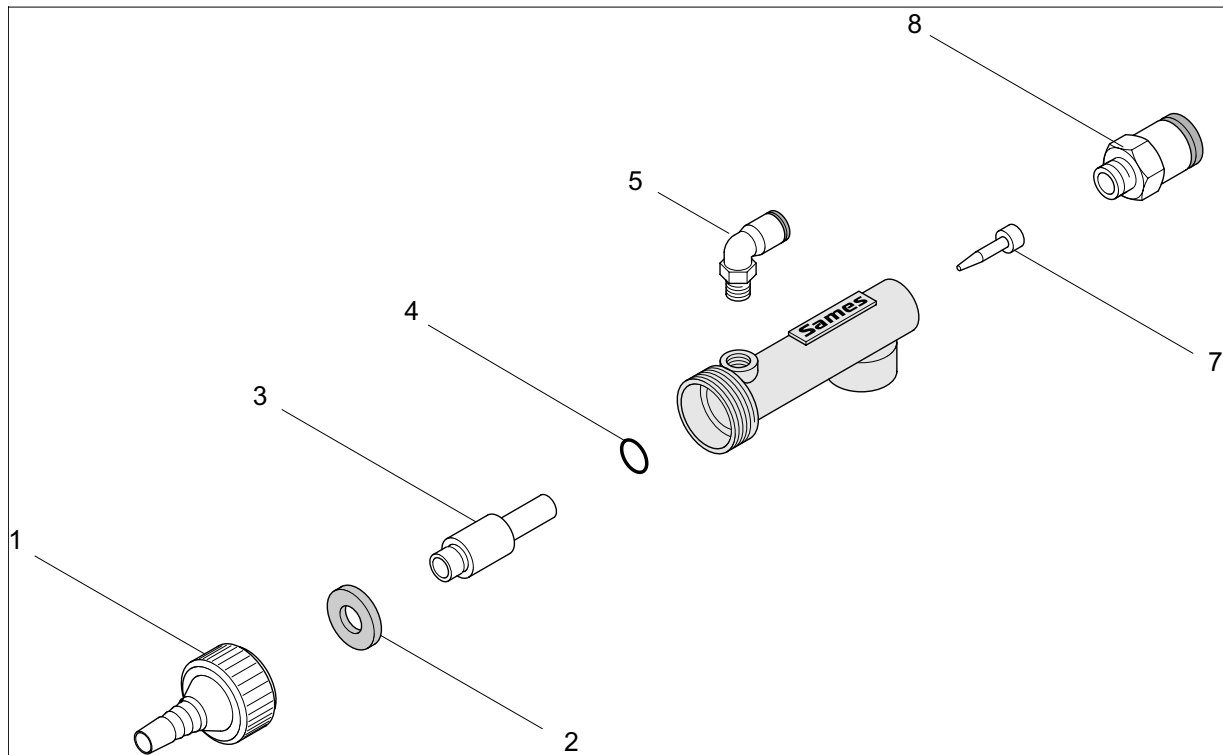

1. DISMANTLING

1.1. DISMANTLING THE "VENTURI" EJECTOR (3)

- Unscrew the nut on the powder output nozzle (1), and remove the porous ring (2).
- Remove the "venturi" ejector (3).

1.2. DISMANTLING THE AIR INJECTOR (7)

- Unscrew the straight fitting (8), then remove the air injector (7).

2. REASSEMBLY

2.1. REASSEMBLY OF THE AIR INJECTOR (7)

- Put the air injector (7) in position in the barrel of the plunger, then screw the straight fitting (8) back in place.

2.2. REASSEMBLY OF THE "VENTURI" EJECTOR (3)

IMPORTANT : It is essential to check that the O-ring (4) is in place.

- Check the state of the O-ring (4), and replace it if necessary.
- Put the "venturi" ejector (3) in the barrel of the plunger.
- Screw the powder output nozzle (1) back into place.

BJ04-03-B - SHORT NOZZLES (FLAT AND ROUND SPRAY)

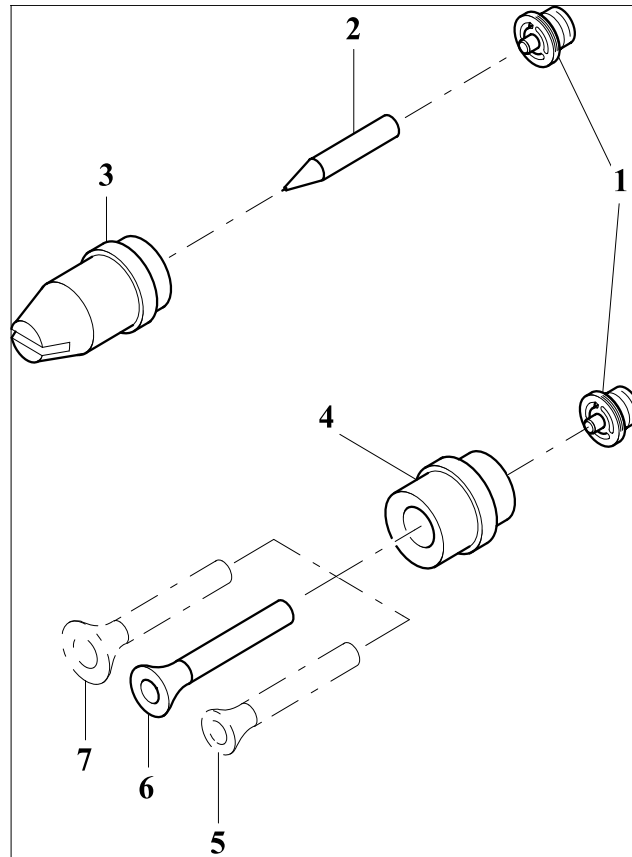

Item	Article code	Description	Qty	Sales unit
------	--------------	-------------	-----	------------

	931575	FLAT SPRAY NOZZLE BSR 201-P		1
1	733817	Rear body	1	1
2	544795	Installed flat spray electrode	1	1
3	930347	Front body of flat spray electrode	1	1

	931590	ROUND SPRAY NOZZLE BSR 096		1
1	733817	Rear body	1	1
4	739793	Nozzle front body	1	1
5	544827	Diam. 16 mm Deflector (L = 45 mm)	Optional	1
6	544791	Diam. 20 mm Deflector (L = 45 mm)	1	1
7	544828	Diam. 27 mm Deflector (L = 45 mm)	Optional	1

BJ04-04-B - NOZZLES LENGTH 150 MM (FLAT AND ROUND SPRAY)

OPTIONAL

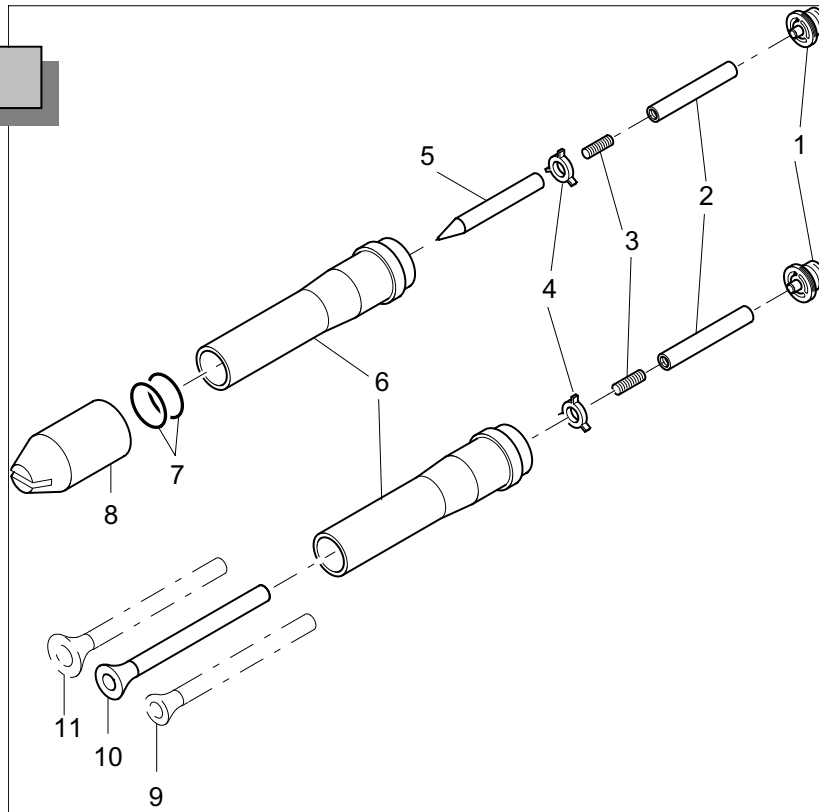

Item	Article code	Description	Qty	Sales unit
	1502642	FLAT & ROUND SPRAY LG. 150 MM NOZZLES		1
	1502347	FLAT SPRAY NOZZLE BSR 202-P		1
1	733817	Rear body	1	1
2	549187	Installed extension piece	1	1
3	X3ASSC186	Headless screw	1	1
4	544035	Centering device	1	1
5	643184	Installed long electrode	1	1
6	931254	Front body extension piece	1	1
7	J2FENV288	O-ring	2	1
8	931256	Front body	1	1
	931571	ROUND SPRAY NOZZLE BSR 097		1
1	733817	Rear body	1	1
2	549187	Installed extension piece	1	1
3	X3ASSC186	Headless screw	1	1
4	544035	Centering device	1	1
6	931254	Front body extension piece	1	1
9	544829	fl 16 mm deflector	Optional	1
10	544793	fl 20 mm deflector	1	1
11	544830	fl 27 mm deflector	Optional	1

BJ04-05-B - NOZZLES LENGTH 250 MM (FLAT AND ROUND SPRAY)

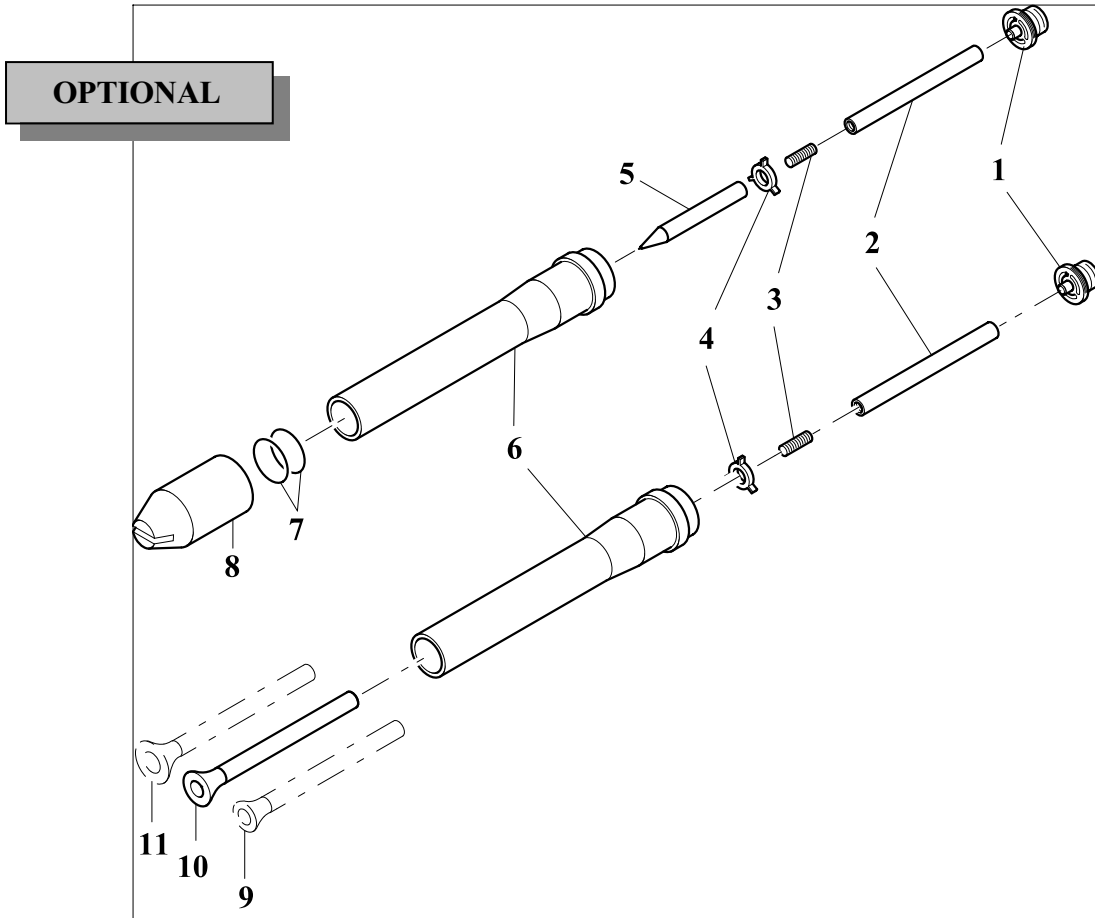

Item	Article code	Description	Qty	Sales unit
	1502643	FLAT & ROUND SPRAY LG. 250 MM NOZZLES		1

	1502348	FLAT SPRAY NOZZLE BSR 203-P		1
1	733817	Rear body	1	1
2	549188	Installed extension piece	1	1
3	X3ASSC186	Headless screw	1	1
4	544035	Centering device	1	1
5	643184	Installed long electrode	1	1
6	931255	Front body extension piece	1	1
7	J2FENV288	O-ring	2	1
8	931256	Front body	1	1

	931572	ROUND SPRAY NOZZLE BSR 098		1
1	733817	Rear body	1	1
2	549188	Installed extension piece	1	1
3	X3ASSC186	Headless screw	1	1
4	544035	Centering device	1	1
6	931255	Front body extension piece	1	1
9	544829	fl 16 mm deflector	Optional	1
10	544793	fl 20 mm deflector	1	1
11	544830	fl 27 mm deflector	Optional	1

BJ04-12-A – FLAT SPRAY NOZZLE BSR 205-P

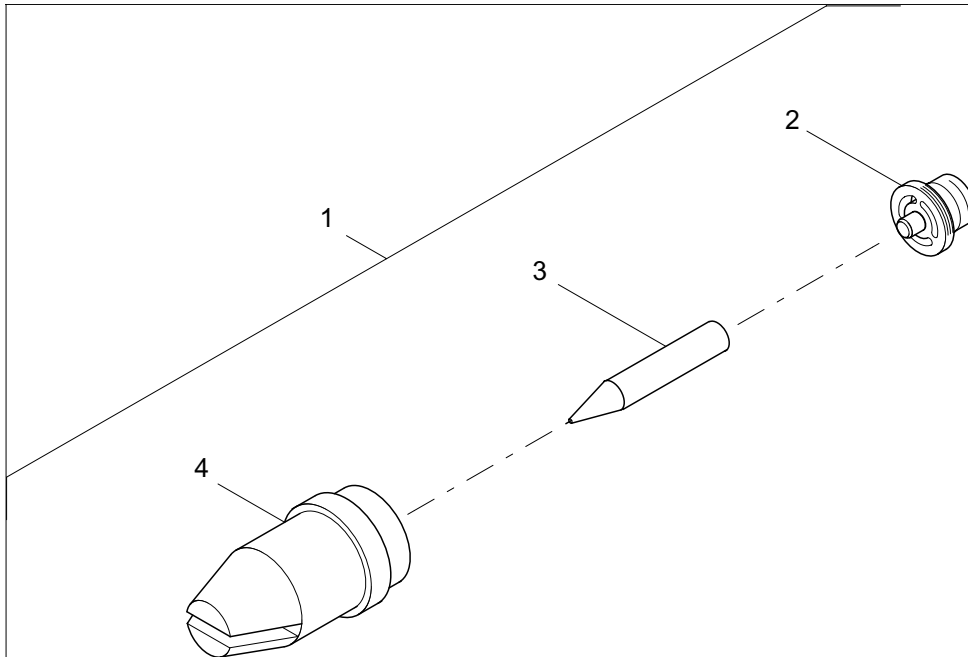

Item	Article code	Description	Qty	Sales unit
1	1515467	FLAT SPRAY NOZZLE BSR 205-P		1
2	733817	Rear body	1	1
3	544795	Installed flat spray electrode	1	1
4	1309277	Front body of BSR 205-P flat spray electrode	1	1

BK01-03-C - SRV 416 AUTOMATIC SPRAY APPLICATOR - 1509013

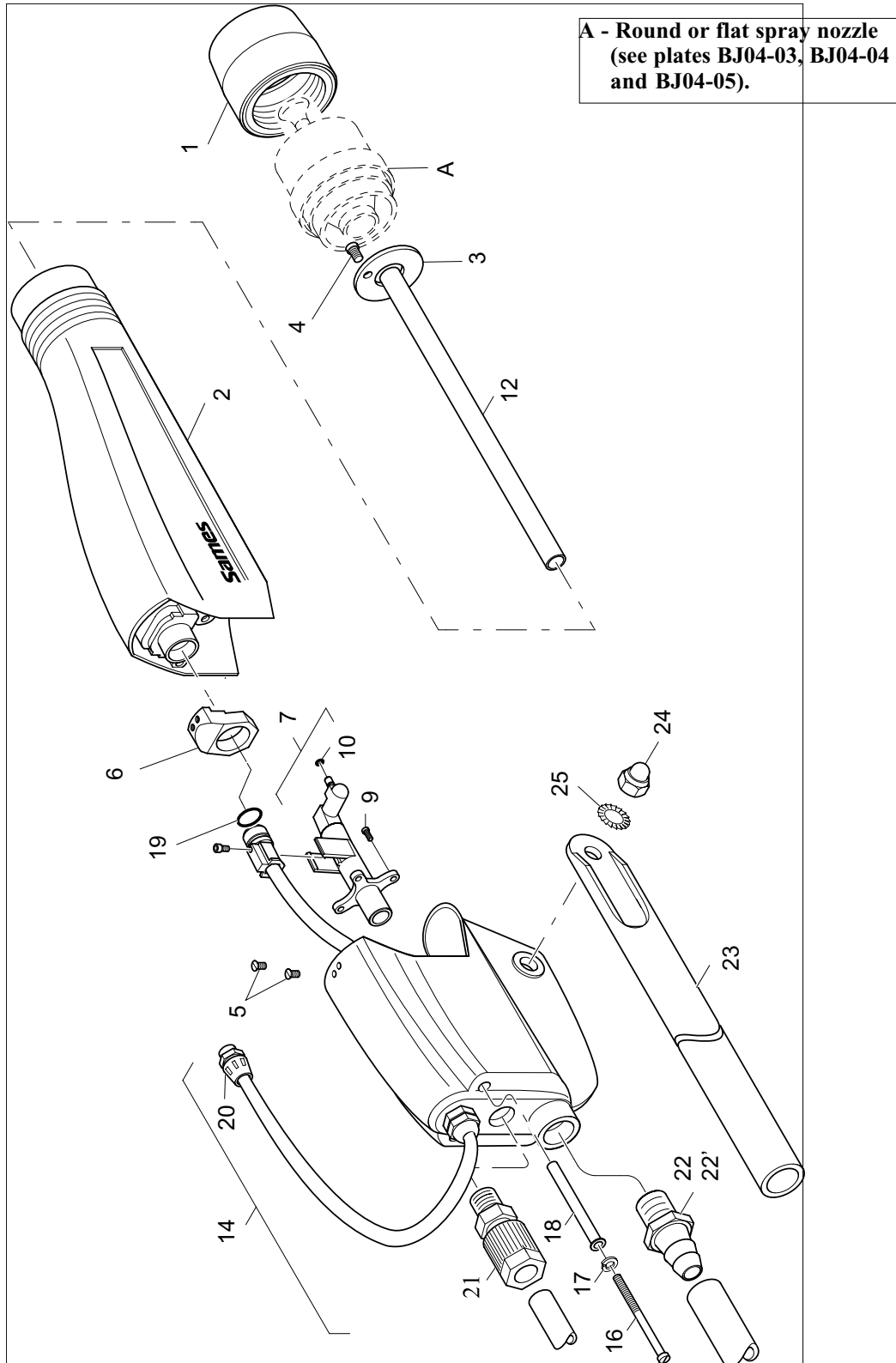

BK01-04-C - SRV 416 AUTOMATIC SPRAY APPLICATOR - 1509013

Item	Article code	Description	Qty	Sales unit
	1509013	SRV 416 automatic spray applicator		1
1	739794	Nozzle nut (not supplied with nozzle)	1	1
2	1514967	Barrel (with cascade)	1	1
3	1402829	Nozzle washer	1	1
4	X3AVSY066	Screw	1	1
5	X9PVFB117	Screw	2	1
6	1406339	Strengthening piece	1	1
7	1502068	SRV 416 mounted air distributor (comprising 9 and 10)	1	1
9	X3AVSY066	Screw	4	1
10	J2CTCN359	O-ring seal	1	1
12	1406589	Powder duct	1	1
14	1513765	Rear body with cable	1	1
16	1402723	M 3 x 70 screw	2	1
17	X3EDWR003	M 3 GROWER washer - zinc-plated	2	1
18	1402731	Spacer	2	1
19	J2FTCF439	O-ring 8.1 / 1.6 - viton	1	1
20	E4PTSF430	7 contacts male plug "MINEX"	1	1
21	F6RPUK319	Air fitting Dia. 6/8 mm	1	1
22	1406632	Powder supply fitting inner Dia. 11 mm	1	1
22	1406634	Powder supply fitting inner Dia. 13 mm (1/2)	1	1
23	449923	Spray applicator support tube	1	1
24	X2KEHB008	M 8 cap nut	1	1
25	X2BDVX008	Fan type lock washer	1	1

	1200550	Low voltage extension cord length 15 m	1	1
	1502148	Complete tools (comprising tools NB 1 - 2 and 3)	1	1
	W6CVTC064	Tool NB 1 (BTR 2.5)	1	1
	W6CVTC052	Tool NB 2 (BTR 3)	1	1
	W6TRND063	Tool NB 3 (screw driver)	1	1

BK02-01-A - REPLACING THE POWDER DUCT

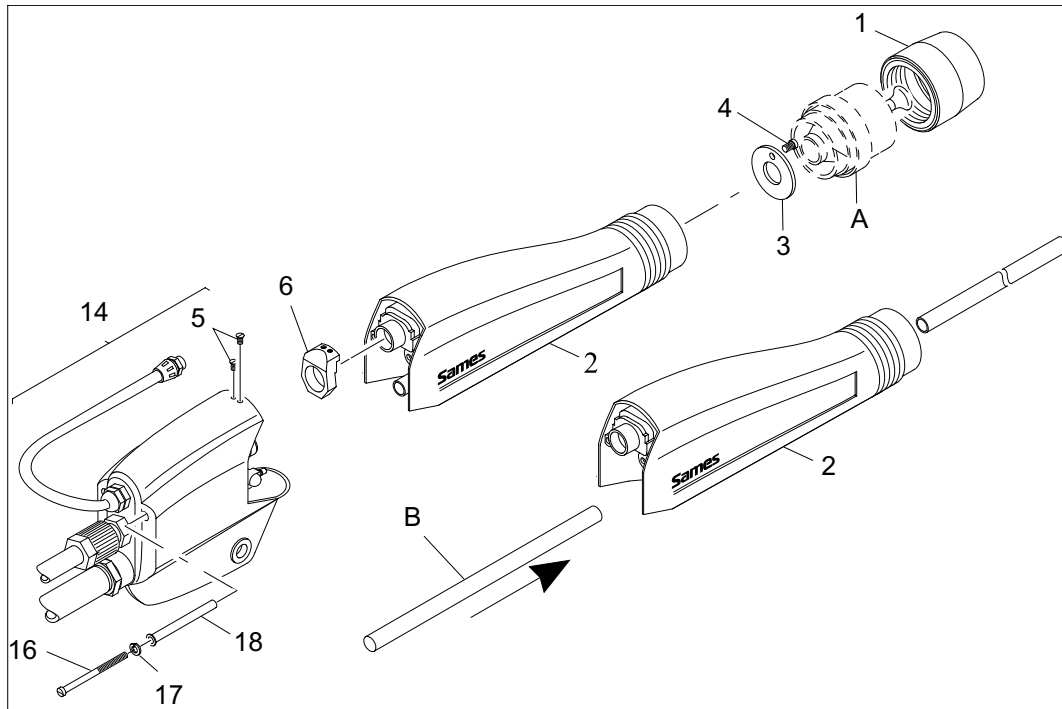

1 - REPLACING THE POWDER DUCT

1.1 - DISASSEMBLING THE POWDER DUCT

- Unscrew nozzle nut (1).
- Remove nozzle (A).
- Remove the screws (5).
- Separate the rear body (14) from the barrel (2) after removing the screws (16) with the tool Nb 2 (W6CVTC052). Take care not to lose washers (17) and spacers (18).
- Push the powder duct (12) from the barrel with a rod \varnothing 12 mm (B).

1.2 - REASSEMBLING THE POWDER DUCT

- Carry out the same operations as for disassembling, in the reverse order.

2 - REMOVING/REPLACING THE MOUNTED BARREL

Note: It is not possible to remove the cascade from the barrel. Thus, you have to replace the whole barrel in order to change the cascade.

2.1 - DISASSEMBLING THE MOUNTED BARREL

- Remove the screws (5).
- Separate the rear body (14) from the barrel (2) after removing the screws (16) with the tool Nb 2 (W6CVTC052). Take care not to lose washers (17) and spacers (18).
- Extract the powder duct (12).
- Remove the nozzle nut (1).
- Remove the screw (4) and the nozzle washer (3).
- Remove the strengthening piece (6).
- Replace the barrel (2).

2.1 - DISASSEMBLING THE MOUNTED BARREL

- Carry out the same operations as for disassembling, in the reverse order.

BK05-A - REPLACING THE LOW VOLTAGE CABLE (CABLE KIT)

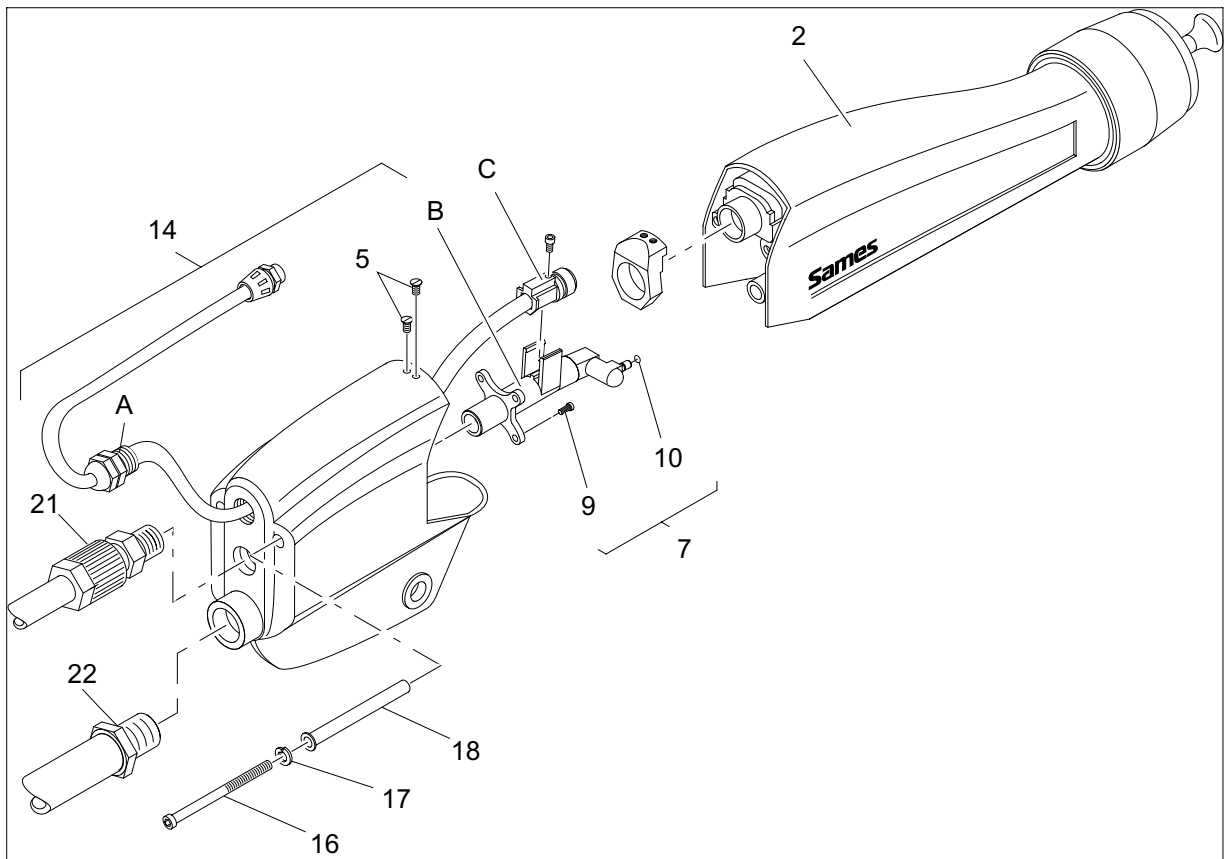

IMPORTANT NOTE : THIS OPERATION MUST BE DONE BY A SAMES AGENT.

1 - REPLACING THE LOW VOLTAGE CABLE

- Unscrew the two screws (5).
 - Separate the rear body (14) from the barrel (2) after removing the two screws (16) with the tool NB 2 (W6CVTC052). Ensure you do not lose the washer (17) and spacer (18).
 - Unscrew the stuffing box (A) of the low voltage cable.
 - Remove the four screws (9) which hold the air distributor (B) inside the rear body (14) with the tool NB 1 (W6CVTC064).
 - Unscrew the air fitting (21).
 - Pull the air distributor (B) outside the rear body.
 - Disassembly the connector (C) from the air distributor (B), by pulling it.
 - Check the condition of O-ring (10); replace it if necessary. Screw the air distributor (B) inside the **new** rear body (14) (don't forget to put the ground terminal on one of the screw (9)).
 - Screw the air fitting (21) on the **new** rear body.
 - Screw the stuffing box on the rear body (14).
 - Dismantle the "MINEX" plug (follow the instructions given with the cable kit).
- Re-assemble the **new** rear body with the barrel, then fix it with the screws (16).

CN01-03-A - GNM 100 (110 V) - 1504741 LOW VOLTAGE GENERATOR

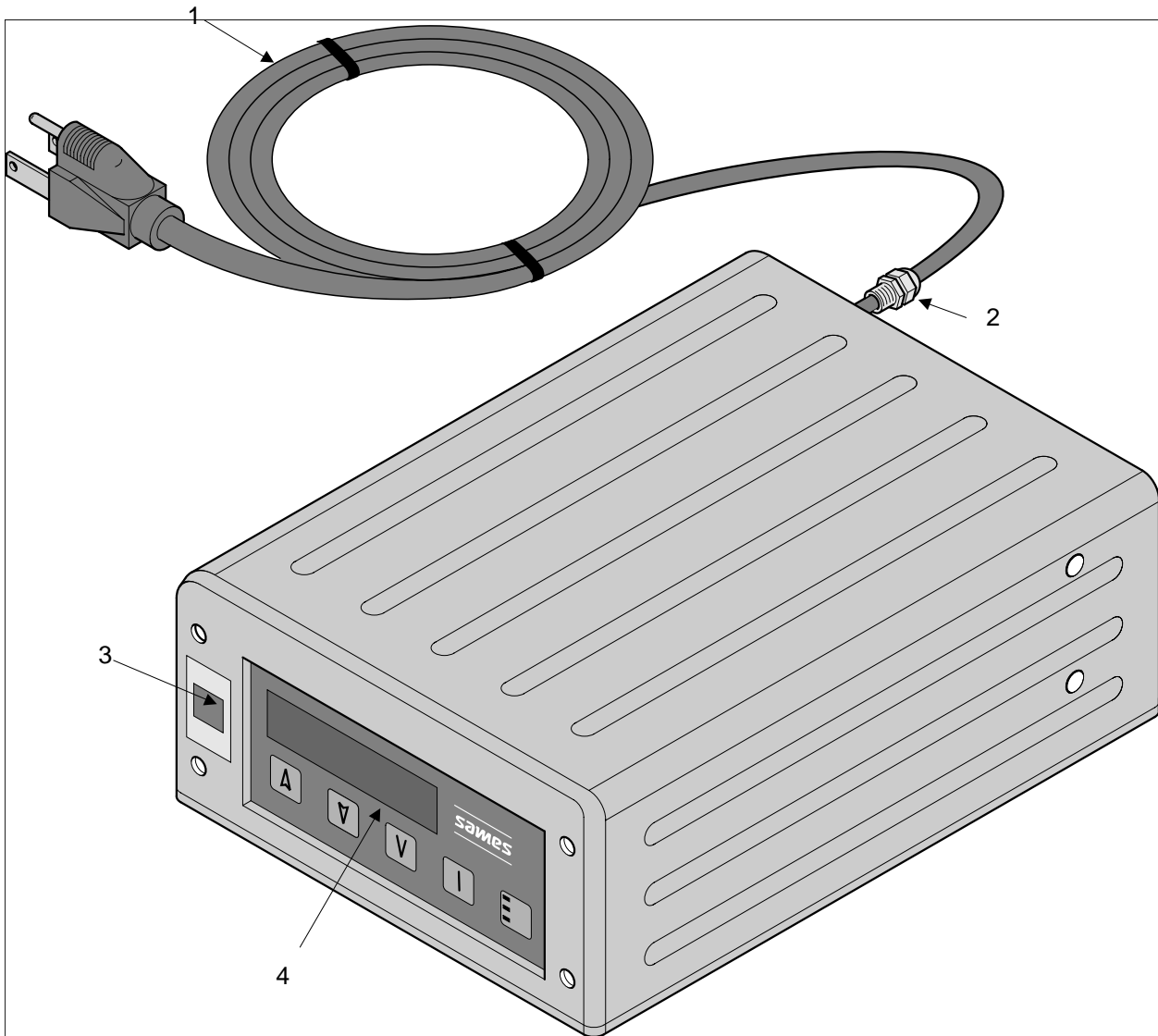

Item	Article code	Description	Qty	Sales unit
	1504741	110 V - GNM 100 LOW VOLTAGE GENERATOR		1
1	1401904	110 V mains cable with tags	1	1
2	E3RPLS016	Mains lead inlet stuffing box	1	1
3	1501024	Complete ON/OFF switch	1	1
4	1504743	Control keyboard with wires	1	1

CN03-A - CONNECTING THE SRV 416 ON THE GNM 100 LOW VOLTAGE GENERATOR

Rear view of the GNM 100

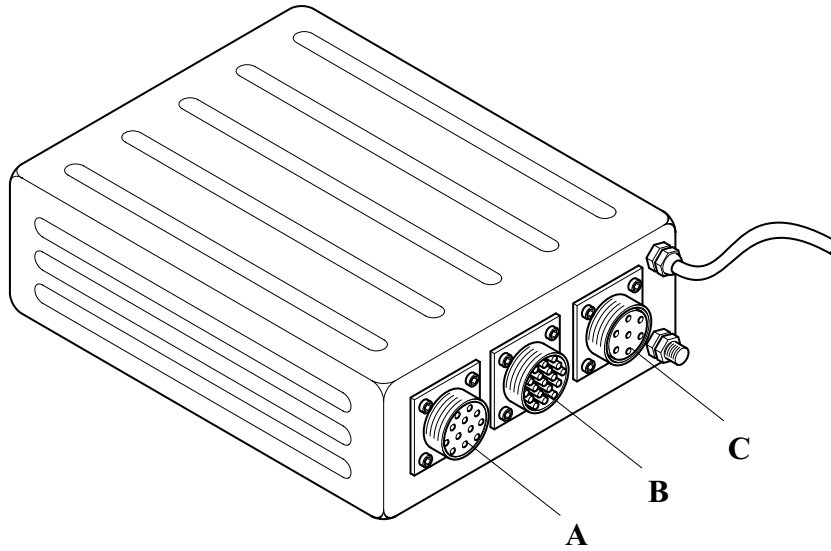

Plug connected on A: SRV 416 connection

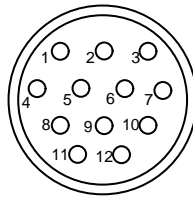
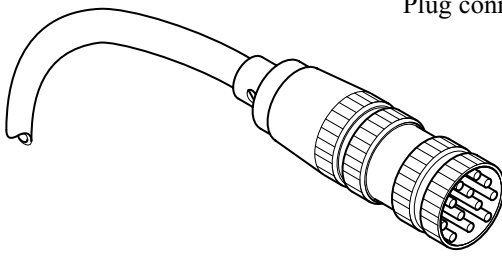

Color of the wires used:

Pin nbr	Color
1	Yellow
8	Shielding
8	Green
8	Brown
8	Black
9	Red
10	Blue
11	White

Plug connected on B: external control

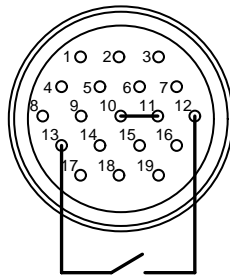
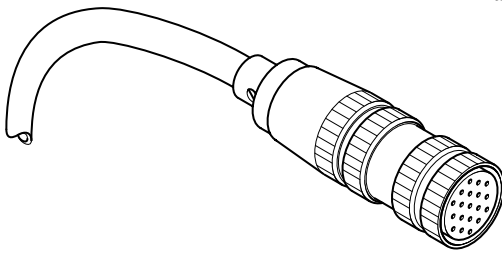

FOR INSTANCE, BY USING AN EXTERNAL SWITCH:

Make a shunt between pins 10 and 11 of the 19 pins plug, and connect the switch between pins 12 and 13.

Other possibilities to control externally the GNM 100 are described on the GNM 100 user manual.

Plug connected on C: electrovalve

For further details on the GNM 100 low voltage generator connections, consult its user manual - RT 6128.

CP01-01-A - CRN 456 CONTROL MODULE

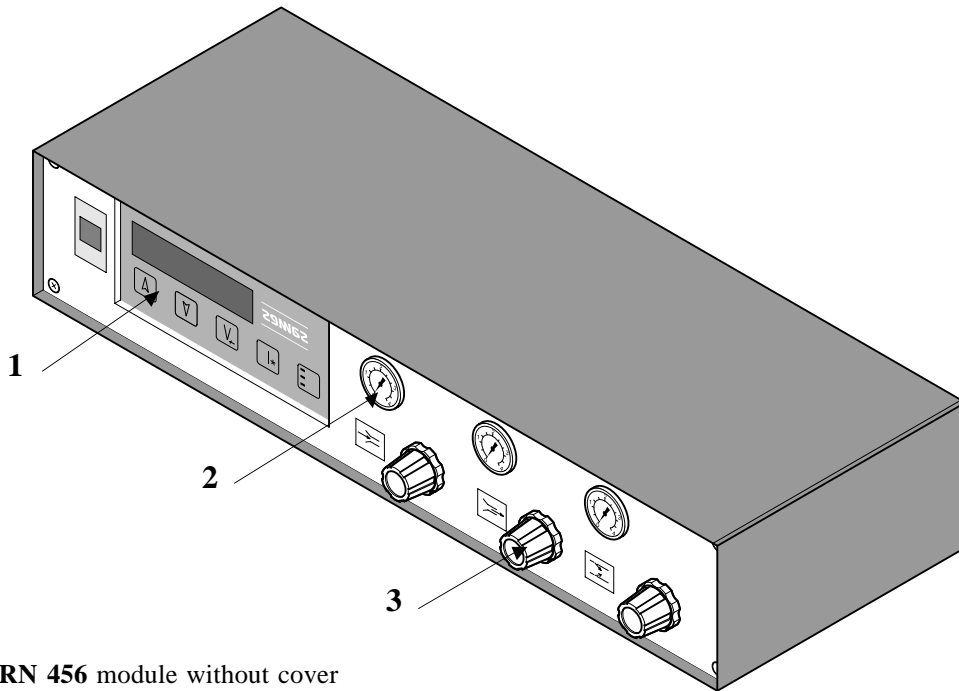

View of CRN 456 module without cover

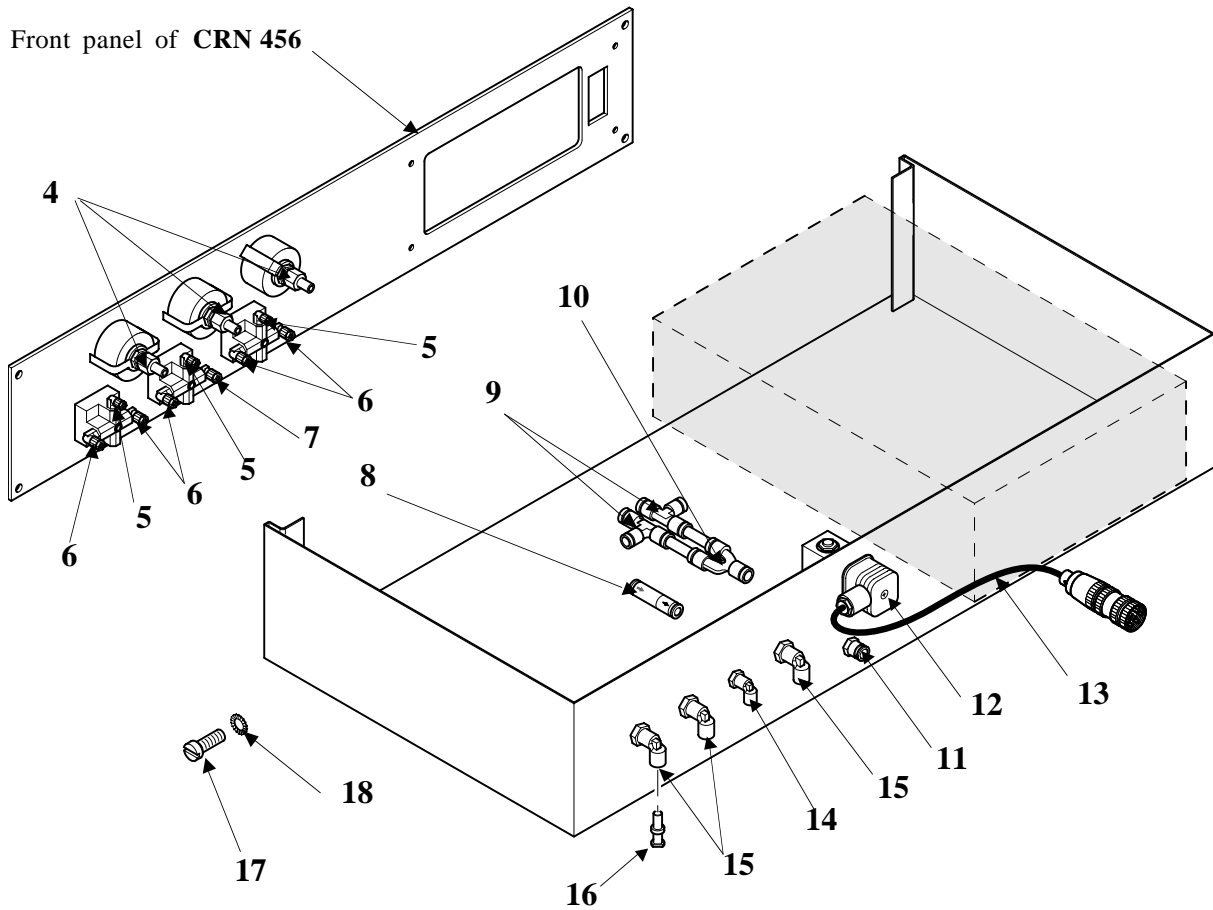

CP01-04-B - CRN 456 - 110 V CONTROL MODULE - 1503099

(refer to plate **CP01-01**)

Item	Article code	Description	Qty	Sales unit
	1503099	CONTROL MODULE CRN 456 - 110 V		1
1	1504741	110 V - GNM 100 LV generator (see plate CN01-03)	1	1
2	R7MCAD061	0 - 4 bar manometer	3	1
3	R4DREG029	0 - 4 bar regulator	3	1
4	F6RLUS457	Diam.6 mm-1/8" straight plug connector	3	1
5	F6RPDK300	Diam.8 mm-1/8" nylon elbow plug connector	3	1
6	F6RPDK303	Diam.8 mm-1/4" nylon elbow plug connector	5	1
7	F6RPDK301	Diam.6 mm-1/4" nylon elbow plug connector	1	1
8	F6RRAF043	No return valve	1	1
9	F6RLTS416	Tee Diam. 8 mm	2	1
10	F6RLYS450	Diam. 8 mm - 1/4"Y union	1	1
11	F6RLUS208	Male union	1	1
12	R3VELM244	110 V - 50 Hz electrovalve	1	1
	F6RLZX417	Washer	2	1
13	1502641	Linking cable GNM 100 -> 110 V electrovalve	1	1
14	F6RLGS198	Wall bracket Diam. 6 mm	1	1
15	F6RLGS199	Wall bracket Diam. 8 mm	3	1
16	F6RLZX397	Dim. 8 mm plug	1	1
17	X2BVKB221	Fixation screw	2	1
18	X2BDZU006	Washer	2	1

	U1GLBT142	Diam. 8 mm hose		m
	U1GLBT152	Diam. 6 mm hose		m
	X2BVKB119	Screw FB 90 M 4 x 12	4	1
	X2BVKY184	Screw CB M 5 x 16	4	1
	X9PDSP032	Washer	4	1
	E2AAJF004	Earth cable		m
	E4CSPF073	Terminal	2	10
	E4CSPR084	Terminal	2	10