



From February 1st, 2017 SAMES Technologies SAS becomes SAMES KREMLIN SAS
A partir du 1/02/17, SAMES Technologies SAS devient SAMES KREMLIN SAS

SAMES  **KREMLIN**



User manual

Spraymium Spray Guns Versions SV/SSV/SP/SX

SAS SAMES Technologies. 13 Chemin de Malacher 38243 Meylan Cedex
Tel. 33 (0)4 76 41 60 60 - Fax. 33 (0)4 76 41 60 90 - www.sames.com

This document may not be passed on or reproduced in any form whatsoever nor may its contents be used or disclosed without express written permission from SAMES Technologies.

The descriptions and characteristics contained in this document are subject to change without notice.

© SAMES Technologies 2008



WARNING : SAS Sames Technologies is registered with the Ministry of Labour as a training institution.
Throughout the year, our company offers training courses in the operation and maintenance of your equipment.
A catalogue is available on request. Choose from a wide range of courses to acquire the skills or knowledge that is required to match your production requirements and objectives.
Our training courses can be delivered at your site or in the training centre at our Meylan head office.

Training Department:
Tel.: 33 (0)4 76 41 60 04
E-mail : formation-client@sames.com

SAS Sames Technologies user manuals are written in French and translated into English, German, Spanish, Italian and Portuguese.

The French version is deemed the official text and Sames will not be liable for the translations into other languages.

Spraymium Spray Guns

Versions SV/SSV/SP/SX

1. Product identification - - - - -	6
1.1. Identifying the version	6
1.1.1. By the barrel.	6
1.1.2. On the air cap ring	6
1.1.3. By the air distributor knurled nut	7
1.1.4. By the air distributor.	7
1.1.5. By the handle.	7
1.1.6. By the base support.	8
1.2. Spraybox control module	8
2. Health and Safety Instructions - - - - -	9
2.1. Regulations	9
2.2. Installation rules	9
2.3. Operating rules	10
2.4. Maintenance rules	10
2.4.1. Products used	11
3. Description of spray gun and Spraybox control module- - - - -	12
3.1. Functions available on spray gun	12
3.2. Functions available from Spraybox control module	13
3.2.1. Welcome Screen	13
3.2.2. Main Screen: Screen A	14
3.2.3. Voltage level preset screen: Screen B.	18
3.2.4. Fault Screen: Screen C	19
3.2.5. Display set-up screen: Screen D	22
3.2.6. Configuration Screen: Screen E	23
3.2.7. Counting Screen: Screen F	24
4. Technical characteristics - - - - -	25
4.1. General spray gun characteristics	25
4.2. Spraybox Characteristics	26
4.3. Compressed air characteristics	26
5. Operation - - - - -	27
6. Special tools - - - - -	28
6.1. Using the multipurpose spanner	30
7. Installation - - - - -	31
7.1. With piston pump for all HP and LP models	31
7.2. With diaphragm pump for the LP models: SV/SSV/SP	32
7.3. With a pressure tank for LP models: SV/SSV/SP	33
8. Operation - - - - -	34
8.1. Paint Recommendations	34
8.1.1. Viscosity.	34
8.1.2. Resistivity.	34
8.1.3. Flash point	34

9. Misuse of the Apparatus - - - - -	34
10. Maintenance - - - - -	35
10.1. Preventive maintenance table	35
10.2. Electropneumatic coupling	36
10.3. Paint Hoses	37
10.3.1. Paint hose - HR version	37
10.3.2. Paint hose - LR version	38
10.4. Air distributor	39
10.5. Spray head assembly	42
10.5.1. Fan Spray Tip, HP version (SX)	42
10.5.2. Round Spray Nozzle, LP version (SV)	44
10.5.3. Fan Spray Nozzle, LP version (SP)	44
10.6. Front of barrel	45
10.7. Trigger	46
10.8. Rear body	47
10.9. High voltage cascade	49
10.10. Barrel / Handle	49
10.11. Handle	50
10.12. Electric diagrams	51
10.12.1. Connection cable Spraymium / Spraybox	51
10.12.2. Spraybox trigger cable	51
10.12.3. Trigger connection	51
11. Cleaning - - - - -	52
11.1. Cleaning the product circuit	52
11.2. Cleaning the spray gun	52
11.2.1. Cleaning the tip, SX (120 and 200 bar) versions	53
11.3. Waste disposal	53
12. Troubleshooting Guide - - - - -	54
13. Spare Parts - - - - -	56
13.1. Spraymium spray guns for high resistivity (HR) solvent paint $\rho > 5M\Omega.cm$	56
13.1.1. Low Pressure Spray Gun Models (LP)	56
13.1.2. High Pressure Models	60
13.2. Spraymium Low Pressure spray guns for solvent paint $0.5 M\Omega.cm < \rho < 500 M\Omega.cm$	62
13.3. Spraymium High Pressure spray guns for solvent paint $0.5 M\Omega.cm < \rho < 500M\Omega.cm$	63
13.4. Common core	64
13.4.1. Seal kits associated with Common core	66
13.5. Air cap adapter assemblies	67
13.5.1. For low pressure models	67
13.5.2. For high pressure models	67
13.6. Nozzle assemblies - LP Models	68
13.6.1. SSV Nozzle assemblies	68
13.7. Needle assemblies	69
13.7.1. For low pressure models	69

13.7.2. For high pressure models	69
13.8. Air Distributor Assemblies	70
13.8.1. For low pressure models	70
13.8.2. For high pressure models	71
13.9. Electropneumatic coupling sets	72
13.10. Paint hoses	73
13.10.1. For Spraymium Low Pressure and High Pressure High Resistivity spray guns	73
13.10.2. For Spraymium Low Pressure and High Pressure Low Resistivity spray guns.	73
13.11. Spraybox Control module	74
13.12. Options for Spraymium Low Pressure spray guns	75
13.12.1. Fan Spray Air Cap	75
13.12.2. 4-finger trigger kit.	75
13.12.3. In-line product filters.	76
13.13. Options for Spraymium High Pressure spray guns	77
13.13.1. X14 Tips for SX version	77
13.13.2. 4-finger trigger kit.	78
13.13.3. Swivel fitting for paint hose	78
13.13.4. In-line product filters.	79
13.14. Appendices	80
13.14.1. Protective hose covering	80
13.14.2. Protective case for spray gun	80
13.14.3. Warning notice and maintenance instructions notice.	80
13.14.4. Safety valve	80

1. Product identification

The various markings on Spraymium spray guns can be used to identify whether low pressure (LP) or high pressure (HP 120 bar or 200bar) configuration is being used.

1.1. Identifying the version

1.1.1. By the barrel

All Spraymium range products carry the same markings on the barrel

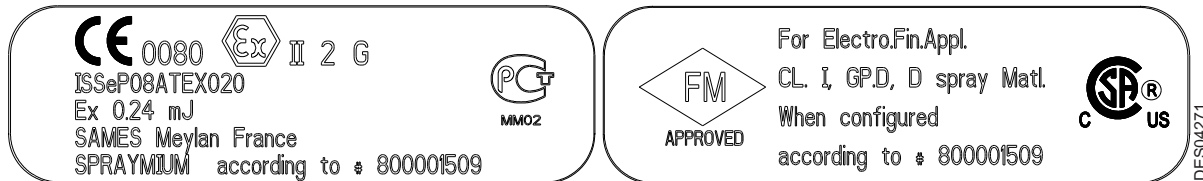

1.1.2. On the air cap ring

There are **three types** of air cap ring:

- One air cap ring common to all **SP/SV08/SV12** low pressure models.
This air cap ring will be marked **SP/SPHVLP/SV**.



SP/SPHVLP/SV

- On air cap ring common to all **SSV08/SSV12** low pressure models.
This air cap ring will be marked: **SSV**.

- One specific air cap ring for the **SX** high pressure models.
This air cap ring will be marked: **SX**.



SX
Tighten with tool



WARNING : The “Tighten with tool” instruction is given because these air cap rings cannot be manually removed if tightened with the tool (P/N: 90000379).

1.1.3. By the air distributor knurled nut

The air distributor knurled nuts are differently coloured, enabling you to tell the low pressure models (SV/SP/SSV) apart from the high pressure models (SX).



1.1.4. By the air distributor

The spray gun will only operate correctly (airflow distribution for shaping and spraying) if the correct air distributor is used.

There are three types of air distributor, engraved with **SV-SSV / SP / SX** (this engraving only appears when the needle assembly is removed).

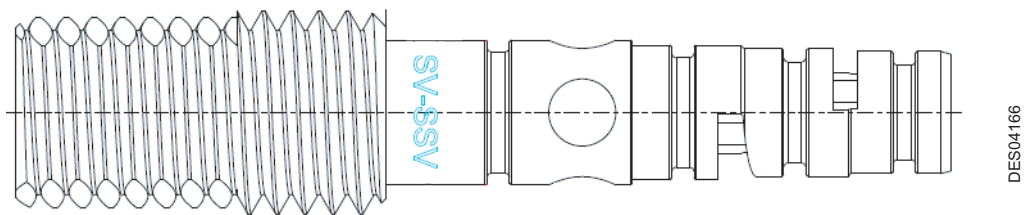

1.1.5. By the handle

The maximum allowable air pressure is marked on the handle.

Max. air pressure
7 bar / 100 psi



1.1.6. By the base support



P max
8 bar / 115 psi

or

P max
200 bar / 2900 psi

or

P max
120 bar / 1740 psi

This marking groups together all spray gun configurations operating at the same product pressure under the same number.

Configuration drawing no.°800001509 (engraved on gun barrel) is used to identify the spray gun models on the basis of their working pressure.

Marking no.	Product pressure	Spraymium models
8000001452	8 bar	SV08-LR; SV08-HR SV12-LR; SV12-HR SSV08-LR; SSV08-HR SSV12-LR; SSV12-HR SP-LR; SP-HR
8000001451	200 bar	SX200-LR; SX200-HR
8000001766	120 bar	SX120-LR; SX120-HR

1.2. Spraybox control module

The **Spraybox** control module should not be installed in an ATEX zone (potentially explosive atmosphere). It is defined as “associated material” for the purposes of the ATEX directive.

Markings

CE Marking

FM/CSA Marking

2. Health and Safety Instructions



WARNING : This equipment may become a safety hazard if it is not operated, disassembled and reassembled in accordance with the instructions given in this manual and in any European Standard or national safety regulations in force.

The warning notice summarizing the safety rules (procedures and precautions) laid out in this instruction manual must be clearly displayed in the area of the spraying workstation.



WARNING : Equipment performance is only guaranteed if original spare parts distributed by SAMES Technologies or Kremlin Rexson are used.

2.1. Regulations

The **Spraymium** spray gun must always be used according to the requirements stipulated in the standards and regulations in force concerning painting and clear coat methods (see European Standard EN 50.053 part 1 in particular).

The Pollution Degree Rating of the Spraymium is "Pollution Degree 2" following IEC-664-1 standard **Pollution Degree 2:** Normally only non-conductive pollution occurs. Temporary conductivity caused by condensation is to be expected.



WARNING : Before any use of the **Spraymium** spray gun, check that all operators

- have previously been trained by the companies Sames Technologies or Kremlin Rexson, or by their distributors registered by them for this purpose.
- have read and understood the user manual and all rules for installation and operation, as listed below.

It is the responsibility of the operator's workshop manager to ensure these two points and it is also his responsibility to make sure that all operators have read and understood the user manuals for any peripheral electrical equipment present in the spraying area.

2.2. Installation rules

- The control module must not be installed **where there is a potential explosion risk.**
- It must be impossible to start up the control module before the spray booth air extraction system is in operation.
- The control module must be properly connected to the ground terminal on the device.
- The paint (or solvent) pump and tank must be connected to a ground terminal on the device.
- The paint supply pump used for models SX 200 must have a maximum ratio of 40:1 and 20:1 for models SX 120, must be fitted with a safety system limiting the pressure to 260 bar (SX 200) and to 130 bar (SX120) at the pump output, and the pump air supply must be fitted with a safety valve limiting the pressure to 6.5 bar maximum.
- All metal parts of the apparatus (paint pumps, containers, stools, turntables, etc.) less than three metres from the spray gun must be grounded.
- The floor on which the operator works must be anti-static (bare concrete or metal duckboard). Never use an insulating floor covering.

- Naked flames, glowing objects or a devices likely to produce sparks (other than the atomizer) must not be used inside the booth.
The storage of inflammable products, or vessels that have contained them, close to the booth or in front of the doors is prohibited.
- Pots and tubs containing paint or solvent must always be closed after use.
- The spraying area must be kept clean and clear of any unnecessary items.
- **In the explosive area**, it is forbidden to use any non-certified electrical or non-electrical equipment such as electronic extension leads, multiple socket adapters, switches, etc.

2.3. Operating rules

- The ventilation system must be checked on a daily basis to ensure it is working properly.
- Performance checks must be carried out on the extraction control system once a week.
- Before starting to spray, check that the nozzle/tip and air cap are fitted to the gun and that the air cap ring is fully tightened. **The SX models are inflammable if the air cap ring is removed.**
- All metal parts of the booth and parts to be painted must be correctly grounded. Ground resistance must be less than or equal to 1M Ω (measurement voltage 500 V). This resistance value must be regularly checked.
- The operator must wear antistatic shoes and hold the **Spraymium** spray gun bare-handed or with gloves that are either antistatic or specially adapted to allow direct contact between the handle and the operator's hand.
- Ensure that anyone who enters the spraying area is wearing antistatic shoes or is otherwise grounded.
- The operator must also wear ear defenders when using Spraymium spray guns ([see § 4 page 25](#)).
- Never throw or drop the electrostatic spray gun. Dropping the gun could damage the high voltage generator and cause incendiary sparking.
- Never point the spray gun towards a person.
- Never use the apparatus in the following situations:
 - 1 If you notice an air leak from the spray gun when the trigger is released.
 - 2 If the spray gun keypad has become detached.
 - 3 If the spray gun electrical connector catch is not held securely in place with two safety screws.
 - 4 If the spray gun barrel, handle or rear body show signs of an impact that may have deteriorated the air-tightness of internal components.
- Use paints whose flash point is at least 5°C higher than the ambient temperature.
- Follow the precautions specified for the paints and solvents used (e.g. wear a mask etc.).
- After use of the spray gun, ensure the "trigger safety" is in the safe position.
- Close and bleed the air and paint feed before leaving the device shut down for an extended period.
- Check the paint hose is in good condition before starting to operate the device.
- The electropneumatic coupling, held in place by two safety screws **MUST NEVER BE DISCONNECTED IN A POTENTIALLY EXPLOSIVE ATMOSPHERE.**
- If any of the following elements are damaged, all operations with the device must be stopped: barrel, handle, rear body, electropneumatic coupling, air cap or air cap ring.

2.4. Maintenance rules

- Service regularly and repair the electrostatic spraying equipment in accordance with the instructions in this user manual.
- Metal containers only should be used to hold cleaning liquids and they must have a reliable ground connection.
- Before any maintenance or servicing operation:
 - 1 Disconnect the control module from the power supply.
 - 2 Check that the air and paint circuits are not pressurized.
 - 3 Bleed the paint Circuit
- Cleaning operations must be carried out either in authorised areas equipped with a mechanical ventilation system, or using cleaning liquids with a flash point at least 5 °C higher than the ambient temperature.
- Do not reconnect the electrical power supply until the air cap and nozzle/tip have been correctly reassembled on the spray gun.

- Never soak or immerse the atomizer in solvent. If required, the spray gun may be cleaned by wiping with a cloth soaked in solvent and then immediately dried to prevent the solvent entering the spray gun.
- Never spray solvent whilst the control module is live.
- Operators must be trained by Sames Technologies or Kremlin Rexson, or by their distributors registered by them for this purpose, to perform **Spraymium** spray gun maintenance operations.



WARNING : It is forbidden to use oil-based solvent and products containing such solvents if aluminium or zinc are present. Users who do not follow these instructions are exposed to explosion risks.

2.4.1. Products used

Given the wide range of products used, and that fact that it is impossible to produce an inventory of these products, Sames Technologie cannot be held liable for:

- incompatibility of product material used when in contact with materials listed below:
 - Stainless steel
 - Fluoroethylenepropylene (FEP)
 - Polyamide-imide (PAI)
 - Polyoxymethylene (POM)
 - Tungsten carbide
 - PTFE elastomer
 - Polypropylene
 - IXEF
 - Glass fibre
 - Ceramics
- Risks related to the use of these products for personnel and the environment include
- wear, incorrect adjustments or malfunction of equipment or machines, together with the non-quality of the application caused by the use of these products.

3. Description of spray gun and Spraybox control module

Spraymium SV, SSV, SP and SX spray guns are designed to spray paint or clear coat whose resistivity is greater than 0.5 MΩ.cm only.

Spraymium spray guns are to be connected to the **Spraybox** control module.

The **SV, SSV, SP and SX** models in the **Spraymium** range can be differentiated by their air cap, air cap ring, air distributor (including needle), and the base support on which the maximum paint pressure is stated.

If paint resistivity is less than 5MΩ.cm up to 0.5 MΩ.cm, an “insulated paint hose” must be fitted to the spray gun in place of the “Short product hose Dia: 2.5 mm” issued as standard.

	Characteristics
Spraymium SV08	Vortex Spray - Low Pressure - Dia: 8 mm
Spraymium SV12	Vortex Spray - Low Pressure - Dia:12 mm
Spraymium SSV08	Super Vortex Spray - Low Pressure - Dia: 8 mm
Spraymium SSV12	Super Vortex Spray - Low Pressure - Dia: 12 mm
Spraymium SP	Fan Spray - Low Pressure - Seat Dia: 1.5 mm
Spraymium SX	Airmix - High Pressure

3.1. Functions available on spray gun

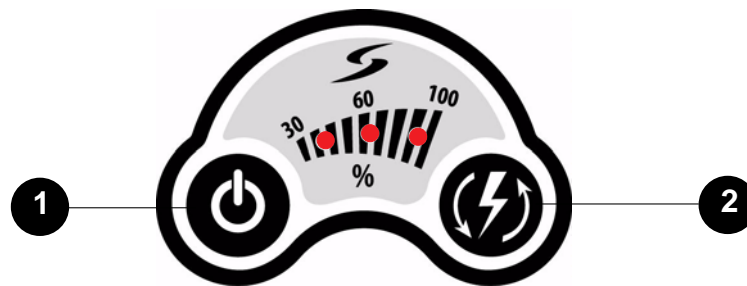

- **Button 1:** Switches high voltage power on or off. If high voltage power is off, none of the LEDs are on.
- **Button 2:** Selects from the Spraybox control module operating voltage presets U30%, U60% or U100%.
 - U100% selected: 3 red LEDs on.
 - U60% selected: 2 red LEDs on.
 - U30% selected: 1 red LED on.

3.2. Functions available from Spraybox control module

3.2.1. Welcome Screen

The **Spraybox** control module displays operating parameters and their settings.

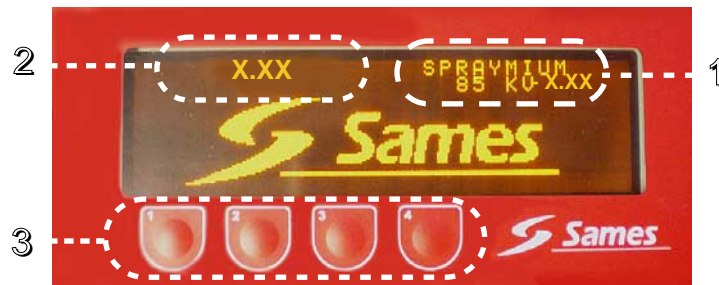

Spraybox control module front panel

This Welcome Screen is the first screen displayed on start-up of the **Spraybox** control module.

- **Area 1:** Shows the type of device connected and maximum allowable voltage as well as the software version of the Spraymium electronic board.
- **Area 2:** Shows the firmware version of the Spraybox.
- **Area 3:** There are four keys which are used to set up the different operating parameters and browse through the various screens.

The control module comes with factory presets. Factory settings are restored in the following cases:

- At start-up when Spraybox is first used.
- When the operator “forces” the factory settings, by holding down keys 1 and 2 at start up, and keeping them held down until the  icon is displayed.

If the factory settings are being used, Screen E is displayed: Configuration Screen ([see § 3.2.6 page 23](#)).

3.2.2. Main Screen: Screen A

At start, the Spraybox displays -0,4 bar (648 psi) during 5 seconds, it is the time necessary for the initialization of the pressure sensor.

Spraybox CE version (P/N # 110000352) without external trigger cable

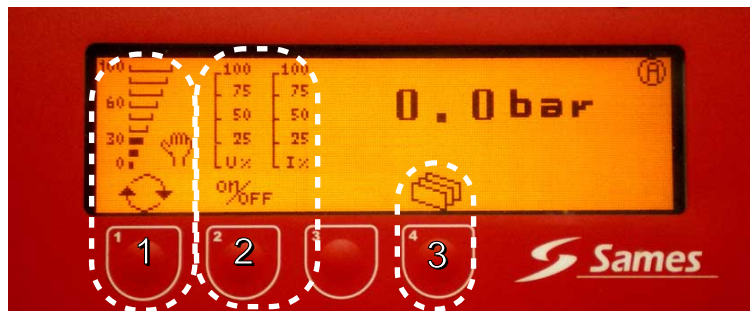

[1]: This area is where presets U30%, U60% or U100% can be selected.



The hand logo is displayed to show that the factory settings have been changed.

[3]: Use this key to switch to the next menu.

Pressing the key brings up the next menu, **Screen B**, whilst keeping the same settings.



[2]: Use this key to authorise or prevent high voltage power.

If high voltage power is authorised:

the first scale shows the voltage supplied to the cascade, expressed as a percentage of the maximum supply voltage.

the second scale shows the current supplied to the cascade, expressed as a percentage of the maximum supply current.

If high voltage power has been disconnected, the screen below is displayed:

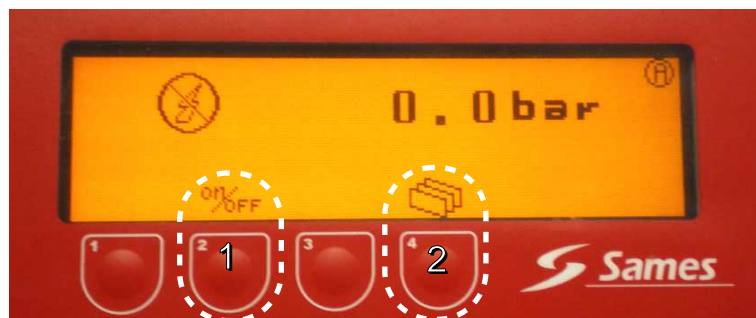

[1]: Use this command to switch high voltage power back on.

Note: it is possible to paint without high voltage power.

[2]: Use this key to switch to the next menu.

Pressing the key brings up the next menu, **Screen B**.



When high voltage power has been reconnected, the next screen is displayed:

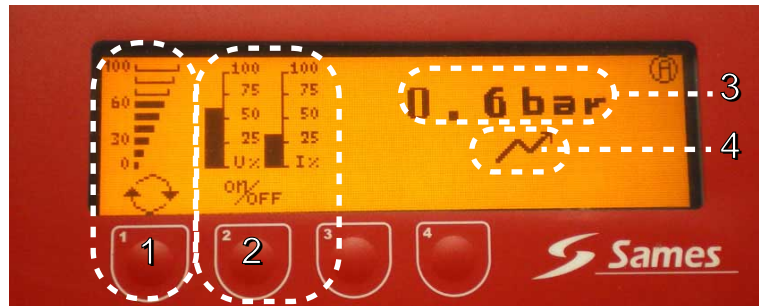

[1]: This area is where presets U30%, U60% or U100% can be selected.



The hand logo is displayed to show that the factory settings have been changed.

[2]: Use this key to authorise or prevent high voltage power.

If high voltage power is authorised:
the first scale shows the voltage supplied to the cascade, expressed as a percentage of the maximum supply voltage.

the second scale shows the current supplied to the cascade, expressed as a percentage of the maximum supply current.

[2]: The air pressure measured in the spray gun is shown in this area:

- Spraying air pressure for models SV/SP and SSV.
- Spray shaping air pressure for models SX.

[4]: When the trigger is pressed, this logo flashes, indicating that high voltage power is on.

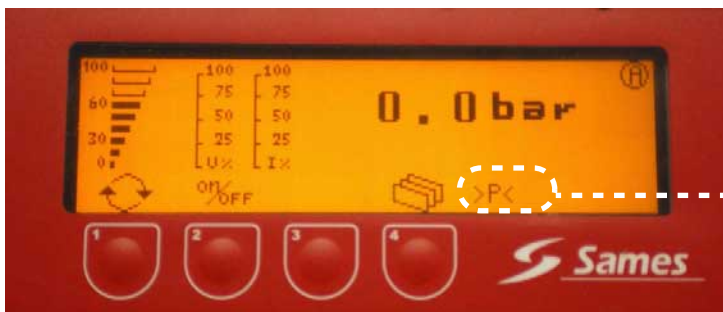

Air pressure insufficient to start high voltage power

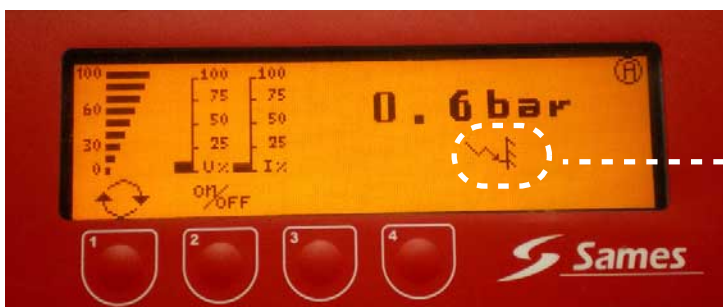

Indicates a generator short circuit: charge efficiency drops.

- The paint is too conductive (if HR hose, replace with LR hose).

- The spray gun is too close to the part.

Spraybox FM/CSA version (P/N # 110000873)

Main screen: Screen A

At start, this screen appears:



After pressing the "On/Off" key (2), the following screen appears:



Press the "ON /OFF" button of the Spraymium, the following screen appears, the operator can work.



Remarks: If the operator presses the "ON /OFF" button of the Spraymium before pressing the "ON/OFF" key (2) on the Spraybox, he cannot get High Voltage.

Spraybox CE and FM/CSA versions with external trigger cable



WARNING : Connect the external trigger cable (P/N # 910008791) before switching on the Spraybox.

Main screen: Screen A

At start, this screen appears:



If circuit between H and S is closed ([see § 10.12.2 page 51](#)), then the following screen appears.



Press the "ON /OFF" button of the Spraymium, the following screen appears, the operator can work.



Remarks: If the operator presses the "ON /OFF" button of the Spraymium before closing the circuit between H and S , he cannot get High Voltage.

3.2.3. Voltage level preset screen: Screen B

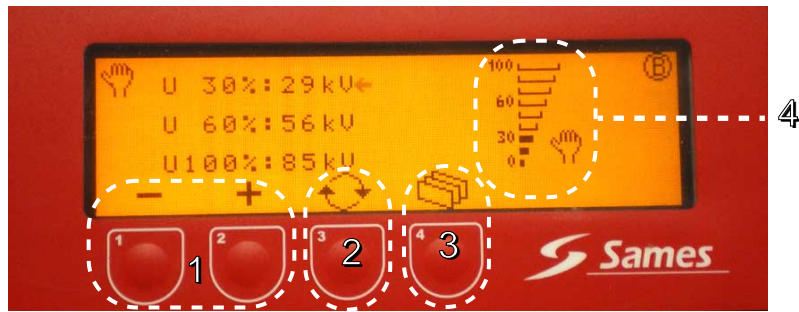

[1]: Use this area to adjust the voltage settings:



The voltage value decreases when the flashing cursor is opposite the parameter to be modified.



The voltage value increases when the flashing cursor is opposite the parameter to be modified.

When these values have been modified, the hand logo appears next to adjusted value. The U30%, U60% and U100% settings can be set to any value between **0 and 85kV** provided that the following logic is complied with:

$U_{100\%} \geq U_{60\%} \geq U_{30\%}$.

The factory presets are as follows:

U 30%: 28 kV

U 60%: 56 kV

U 100%: 85 kV

[3]: Use this key to switch to the next menu.



Pressing the key validates the settings and brings up the next menu: **Screen C.**

[2]: Use this key to place the cursor next to the voltage level to be adjusted.

A flashing cursor is displayed next to the preset voltage value to be changed. The voltage level can then be adjusted as required.

[4]: This area shows the preset voltage level currently being used.

3.2.4. Fault Screen: Screen C

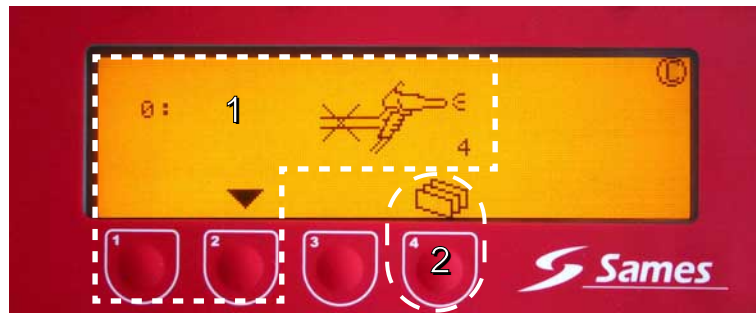

[1]: The fault log is displayed in this area.
The most recent fault is shown with a value of 0 on the left-hand side of the screen.



Faults displayed from oldest to most recent.







Faults displayed from most recent to oldest.







[2]: Use this key to switch to the next menu.

Pressing the key validates the settings and brings up the next menu: **Screen D**.

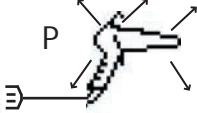

3.2.4.1. Fault list

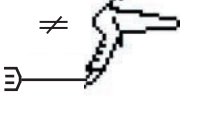
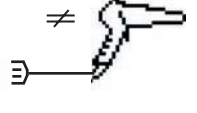
Fault Nr/ Alarm	Icon	Type of default	Possible origin	Corrective Action
1		General fault of the "SPRAYBOX"	Spraybox mothercard failure	Change the Spraybox
2		Computing communication fault with the spray gun	Broken electrical cable	Change the cable
			Failure of the SPRAY-MIUM electronic card Note: After this type of failure, check the tightness of the trigger and of the seal cartridge	Change equipped rear body and check spray gun tightness
			Disconnection of the power supply of the SPRAYMIUM card	Reconnect the connector and secure it thanks to a clamp
			Failure of the Spraybox: supply fuse of Spraymium card is broken.	Change / Repair the Spraybox Change equipped rear body and check spray gun tightness
3		Excessive temperature of the SPRAYBOX	Ambiant temperature superior to 40°C	Lower the temperature of the SPRAYBOX
4		Action of the trigger when switching on the SPRAY-BOX	Presence of air flow when switching on the SPRAYBOX	Do not press trigger when switching on the SPRAYBOX
			Failure of the SPRAY-MIUM electronic card	Change equipped rear body and check spray gun tightness

none	Display -0,4 bar or 648 psi and >P< 	Too high initial pressure measure	Measured pressure superior to 0,14 bar when switching on the SPRAYBOX	Do not press trigger when switching on the SPRAYBOX
	Display of 3rd LED on SPRAYMIUM 		Failure of the electronic card of the SPRAY-MIUM	Change equipped rear body and check spray gun tightness
			Use temperature inferior to 0°C	Use the spray gun at a temperature superior to 0°C
6		Failure of the electronic card of the SPRAYMIUM	Failure of the electronic card of the SPRAY-MIUM	Change equipped rear body and check spray gun tightness
			Use temperature superior to 40°C	Use the sprayer at a temperature inferior to 40°C
7		Cascade power supply cut-off	Broken electrical cable	Change cable
8		General fault of the SPRAYBOX	Failure of the motherboard of the SPRAY-MIUM	Change the SPRAY-BOX
10		Electrical fault	Faulty electrical connections	Test the electrical connections between SPRAYMIUM and SPRAYBOX
			"Trigger external cable" unplugged while SPRAYBOX running	Stop and then restart the SPRAYBOX
11			Faulty electrical connections	Test the electrical connections between SPRAYMIUM and SPRAYBOX
Alarm			The counter of triggers exceeds 500 000 operations	Change both trigger bearing o-rings and seal cartridge (P/N 910005953) - Press Reset key to reset the counter
None	None	Important laps of time between trigger action and high voltage switch-on	Blocked sensor filter	Change filter P/N 900006025

Remark: The Spraybox control module high voltage has to be switched off to acknowledge the faults n°1, n°6 and n°8.

3.2.5. Display set-up screen: Screen D

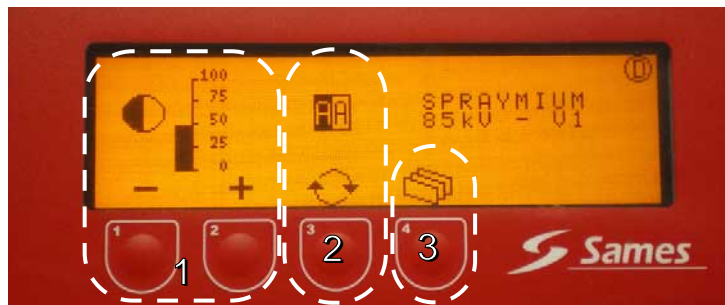

[1]: Use this area to adjust screen contrast. Pressing the buttons operates the following commands:



Reduce contrast, making the screen increasingly lighter.



Increase contrast, making the screen increasingly darker.

The icon and scale indicate the back-lighting level.

[3]: Use this key to switch to the next menu.

Pressing the key validates the settings and brings up the next menu: Screen E.



[2]: Use this key to reverse the screen colours.

Pressing this button toggles between display settings:

- Either the graphics are orange on a black background.
- Or the graphics are black on an orange background.



3.2.6. Configuration Screen: Screen E

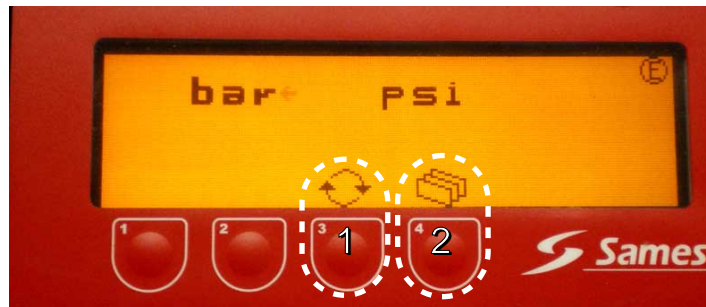

[1]: Use this key to select the unit of pressure measurement.

Pressing this key moves a little arrow that shows the selected unit. The pressure value, expressed in this unit, is displayed on the main menu (Screen A) when the spray gun trigger is held down.

[2]: Use this key to switch to the next menu.

The next menu is displayed:
Screen A.



Note: firmware initialisation only continues if the operator makes a selection and confirms it. The default unit of pressure is the bar.

3.2.7. Counting Screen: Screen F



[1]: Hour counter of operating activated trigger.
 [2]: Counter of trigger actions.
 [3]: Counter of trigger actions with "Reset".

[4]: This key allows to reset the counter ([3]) of trigger actions .

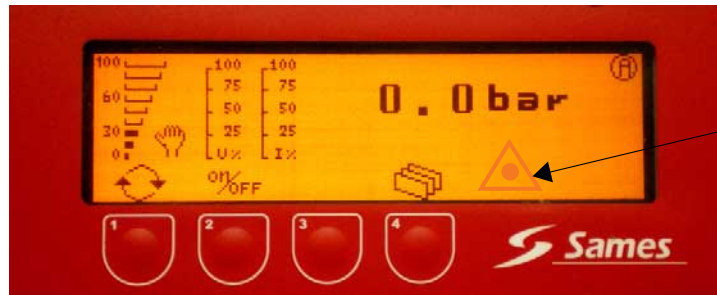

[1]: This blinking signal appears as soon as the counter of trigger actions with "Reset" reaches 500 000. This counter prevents the operator of the necessity of changing both trigger bearing o-rings (P/N # J3STKL082) and seal cartridge (P/N # 910005953 see § 13.4 page 64).

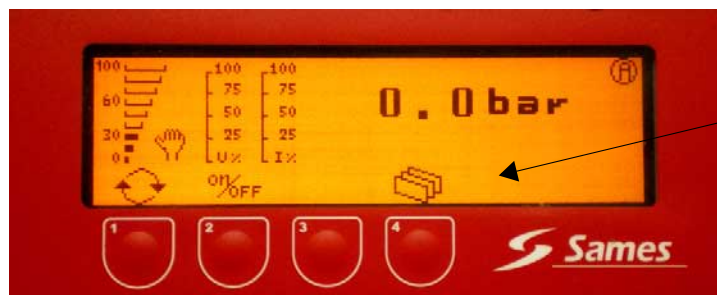

[1]: After pressing the "Reset" key of the screen F, the blinking signal disappears

4. Technical characteristics

4.1. General spray gun characteristics

	SV08	SV12	SSV08	SSV12	SP	SX120	SX200
Spray type	Vortex	Vortex	Super Vortex	Super Vortex	Fan spray	Fan spray Airmix	Fan spray Airmix
Air cap fitted as standard	V08	V12	SSV08	SSV12	P15	X14	X14
Max. paint intake pressure	8 bar	8 bar	8 bar	8 bar	8 bar	120 bar	200 bar
Compressed-air intake pressure	6 bar ± 1 bar						
Mini/ maxi Ambient temperature	0°C - 40°C						
Max. paint flow rate (paint viscosity 25s when measured with AFNOR Cup 4) in cm ³ /min	650	750	650	750	750	550	700
Spray width, 25 cm away	35 cm	40 cm	35 cm	40 cm	18-47 cm	29 cm	29 cm
Air flow rate Nm ³ /h	7.5-17	9-23	7.5-17	9-23	12-25	8	8
Sound pressure (*)	89.4 dB(A)	89.4 dB(A)	89.4 dB(A)	89.4 dB(A)	86.5 dB(A)	85.7 dB(A)	85.7 dB(A)
Recommended paint viscosity (measured with AFNOR Cup 4)	14 to 40 s					≤ 40 s	
Dimensions	320 x 260 x 60						
Weight without hoses or cables	880 g						
Output voltage	Max. 85 kV [+0 kV; -15 kV] (adjustable on Spraymium or Spraybox)						
Output current	100 µA max.						
Short-circuit output current	< 20 µA						
HV cascade input voltage	12 V DC max.						
HV cascade input current	650 mA max.						
Air coupling	1/4 NPS - F						
Paint fitting	1/2 JIC - M						
Paint resistivity ρ	5 MΩ.cm < ρ < 500 MΩ.cm HR Version (high resistivity) 0.5 MΩ.cm < ρ < 500 MΩ.cm LR Version (low resistivity)						
Electrical functions available on the gun	High voltage ON / OFF switch 3 high voltage settings levels						
Electrical / pneumatic connector	The electropneumatic coupling, held in place by two safety screws MUST NEVER BE DISCONNECTED IN A POTENTIALLY EXPLOSIVE ATMOSPHERE.						
Altitude	2000 m maxi.						
Ambiant humidity	0-95% non-condensing						

(*) The weighted equivalent continuous sound pressure level is between 83.7 and 89.4dB(A), depending on spray gun version.

Measurement conditions:

The apparatus was operated to maximum capacity and the measurements taken in the manual paint test booth (sealed booth with glass panels) located in the Sames site in Meylan, France.

Measurement method:

The weighted equivalent sound pressure level (83.7 to 89.4 dBA) is an LEQ value measured during observation periods over at least 30 seconds.

4.2. Spraybox Characteristics

Spraybox Input	
Voltage	90 - 270V AC
Frequency	50 - 60 Hz
Max. current	1 A
Max. power	32 V.A
High Voltage power supply to cascade	
Voltage	3 - 12 V
Max. current	0.65 A
Control circuit power supply	
Voltage	6.5 - 8 V
Max. current	50 mA

4.3. Compressed air characteristics

Required characteristics for compressed-air supply according to standard NF ISO 8573-1

Characteristics	Value
Maximum dew point at 6 bar (87 psi)	Class 4, i.e. + 3 °C (37° F)
Maximum particle size of solid contaminants	Class 3, i.e. 5 µm
Maximum oil concentration	Class 1, i.e. + 0.01mg/m ₀ ³ *
Maximum concentration of solid contaminants	5 mg/m ₀ ³ *

(*): Values are given for a temperature of 20 ° C (68 °F) at 1013 mbar atmospheric pressure.

5. Operation

Pressing the trigger controls non-simultaneous opening of the air valve and then the paint needle. This control can be disabled by using the “trigger safety” lever.

Spraymium spray guns are fitted with a pressure sensor to measure:

- Spraying air pressure on the “low pressure” SV, SSV or SP spray guns.
- Air pressure at the vents on SX spray guns.

This pressure measurement is displayed on the control module. The sensor is used to activate high voltage power supply as soon as the pressure value measured is greater than 0.2 bar.

With the “low pressure” models SV, SSV or SP:

- The selector at the rear of the spray gun can be used to adjust the spray width and automatically control paint flow.
 - Selector fully turned to the left: max. spray width.
 - Selector fully turned to the right: narrow spray (reduced paint flow).
- The knurled nut can be used to adjust paint flow.
 - Tighten screw to reduce paint flow.
 - Loosen screw to increase paint flow.

With the “high pressure” SX model:

- The selector at the rear of the spray gun can be used to adjust the spray width.
- The knurled nut should be fully screwed in. Paint flow is controlled by the pump.
- Selector fully turned to the left: max. spray width.
- Selector fully turned to the right: narrow spray (reduced paint flow).

6. Special tools

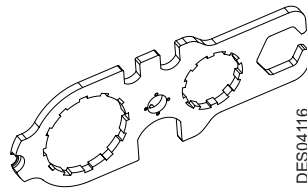

Part number	Description	Qty	Unit of sale
900000379	Multipurpose spanner	1	1

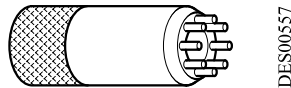

Part number	Description	Qty	Unit of sale
643156	Disassembly/Reassembly tool for SV08 / SV12 nozzle	option	1



Part number	Description	Qty	Unit of sale
W6CVTC001	Key for removing electropneumatic coupling	1	1

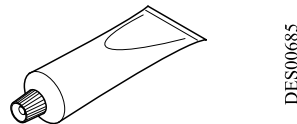

Part number	Description	Qty	Unit of sale
H1GMIN017	White vaseline (100ml)	1	1
H1GSYN037	Red dielectric lubricant for high voltage cascade (50 g)	1	1

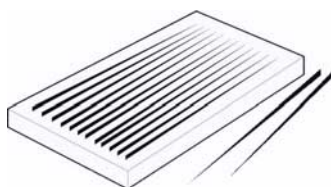

Part number	Description	Qty	Unit of sale
000094000	Unblocking needles for tips 06 - 09	1	1 Pack (12)
000094002	Unblocking needles for tips of over 09	1	1 Pack (12)

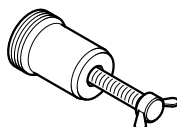

DES00538

Part number	Description	Qty	Unit of sale
1402015	SV/SP diffuser removal tool	1	1
443678	SSV08/SSV12 diffuser removal tool	option	1

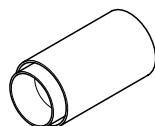

DES00559

Part number	Description	Qty	Unit of sale
003008	SV08/SSV08 diffuser reassembly and alignment tool	1	1
003009	SV12/SSV12 diffuser reassembly and alignment tool	1	1



DES04742

Part number	Description	Qty	Unit of sale
900006126	Adjustment tool of the needle length	1	1



Part number	Description	Qty	Unit of sale
129400923	Air cap cleaning brush	1	10

Additional tools and accessories required:

The tools listed below should be available for product installation and maintenance operations.

- Flathead screwdriver (2 mm)
- Phillip's screwdriver (2 mm)
- Allen keys (3 - 6 mm)
- Torque wrench 1 to 5 Nm (R.304DA Facom) (Sames P/N: 240000095)
- Open-ended spanners (5.5, 14, 16, 17, 24 and 27mm)
- Socket wrench (socket diameters 4, 11 and 13mm)
- Flat nose pliers
- Pin punch (1 - 3 mm)
- Cutting pliers

6.1. Using the multipurpose spanner

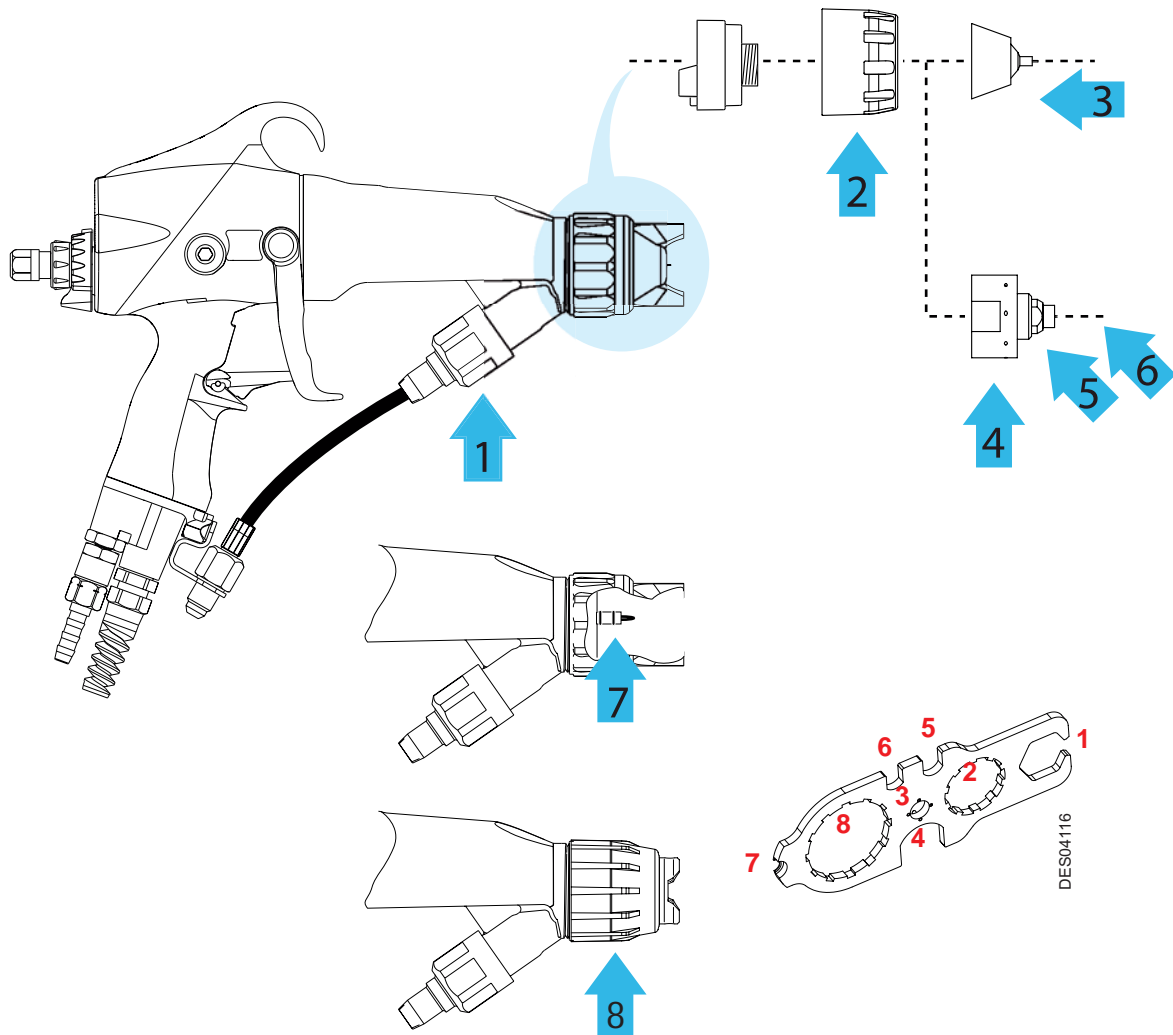

- 1 : Barrel-side paint hose nut
- 2 : Air cap adapter nut
- 3 : Tighten the fitted low pressure nozzle assembly (SV and SP)
- 4 : Tighten the fitted low pressure nozzle assembly (SSV)
- 5 : Tighten the injector (Dia 12 mm) onto the air cap (SSV)
- 6 : Tighten the injector (Dia 8 mm) onto the air cap (SSV)
- 7 : Remove the seal cartridge from the barrel
- 8 : Tighten the air cap ring on the high pressure models (SX)

7. Installation



WARNING : Before any work, please refer to the installation rules ([see § 2.2 page 9](#)).

7.1. With piston pump for all HP and LP models

1	General air supply
2	Air filter
3	Main air valve
4	Pump air shut-off valve
5	Air pressure regulator
6	Spraying air filter/regulator
7	Spraying air valve
8	Spraybox control module
9	Spray gun air supply hose
10	Spraymium Spray Gun
11	Low voltage power supply cable
12	Pump (complies with ATEX Directive)
13	Drain valve
14	Product filter
15	Product feed hose
16	Mains power cable (220V + ground) or (115V + ground)
17	Warning sign
18	Potentially explosive atmosphere
19	Area with no risk of explosion

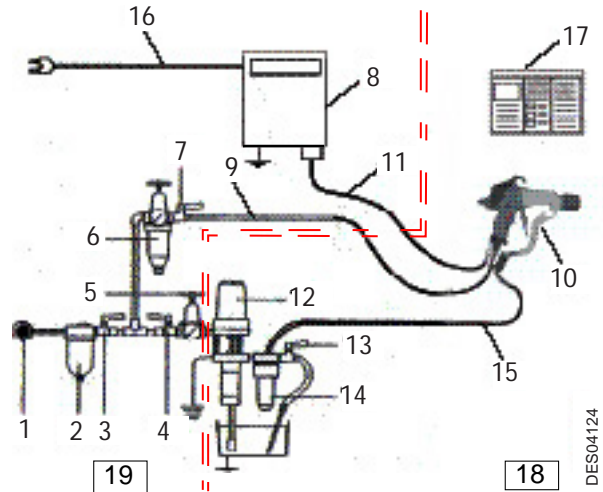

You are advised to fit a filter equipped with a 168µm screen (for the HP models) or 280 µm screen (for the LP models) ([see § 13.14 page 80](#)).

The paint supply must be installed in a well-ventilated area.

The paint container and pump must always be electrically grounded.

The dump hose must be submerged in the paint.



WARNING : The paint supply pump used with the SX models:

- must have a maximum ratio of 40:1 for the SX200 version and 20:1 for the SX120 version.
- must be fitted with a safety system limiting pump output pressure to 260 bar maxi. for the SX200 version and 130 bar for the SX120 version.
- and the pump air supply must be fitted with a safety valve limiting pressure to 6.5 bar max.

7.2. With diaphragm pump for the LP models: SV/SSV/SP

1	Part to be painted
2	Spraymium Spray Gun
3	Single-phase mains, 220 V, 50 Hz + ground
4	Air pressure regulator 0-6 bar - 50 m ₀ ³ /h (for adjusting the spraying air)
5	Compressed air network
6	Stop cocks
7	Oil-removing filter
9	Air pressure regulator 0-6 bar - 5 m ₀ ³ /h For adjusting the regulator control pressure (paint flow rate setting)
10	Air pressure regulator 0-6 bar - 20 m ₀ ³ /h (for adjusting the pump air supply)
12	Potentially explosive atmosphere
13	Area with no risk of explosion
14	Paint flow rate regulator
15	Diaphragm pump (complies with ATEX Directive)
16	Strainer
17	Paint container

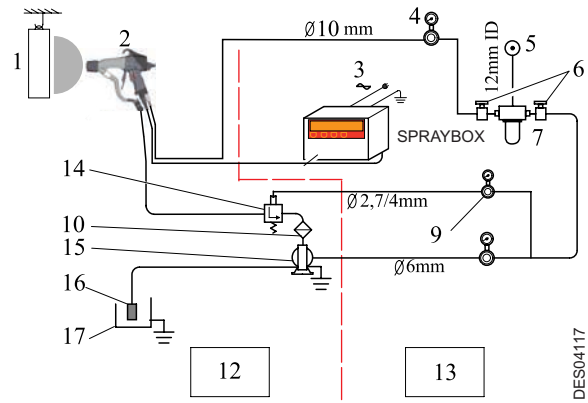

Note: m₀³/h volume at 1013 mbar atmospheric pressure and a temperature of 20°C (68°F) .

It is recommended to fit the diaphragm pump with a valve on the return line to the paint container to prime the pump and stir the paint.



WARNING : For the safety of the painter, the paint container, the diaphragm pump, and the paint filter, if it is metal, must be electrically grounded.

7.3. With a pressure tank for LP models: SV/SSV/SP

1	Part to be painted
2	Spraymium Spray Gun
3	Single-phase mains, 220 V, 50 Hz + ground
4	Air pressure regulator 0-6 bar - 50 m ₀ ³ /h (for adjusting the spraying air)
5	Compressed air network
6	Stop cocks
7	Oil-removing filter
9	Air pressure regulator 0-6 bar - 5 m ₀ ³ /h For adjusting the regulator control pressure (paint flow rate setting)
10	Filter
11	Pressure tank (complies with ATEX Directive)
12	Potentially explosive atmosphere
13	Area with no risk of explosion

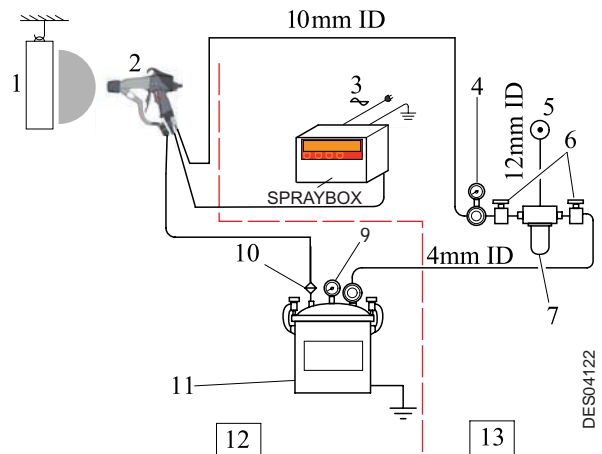

Note: m₀³/h volume at 1013 mbar atmospheric pressure and a temperature of 20°C (68°F).
 You are advised to fit a pneumatic stirrer on the pressure tank to stir the paint.
 A filter with a screen should be fitted at the spray gun paint hose inlet.



WARNING : For the safety of the painter, the pressure tank and the paint filter, if it is metal, must always be electrically grounded.

8. Operation

8.1. Paint Recommendations

In general, all paints and clear coats used with conventional pneumatic spray guns (including slightly metallic paints) can be used in the normal way with the Spraymium spray gun.

8.1.1. Viscosity

The best results are obtained with a viscosity ranging from 25 to 30 seconds, measured with AFNOR cup 4. However, paints with a lower or higher viscosity (for example 14 to 40 seconds or more) can be sprayed.

8.1.2. Resistivity

Use a paint whose resistivity is suitable for the Spraymium spray gun model that you are using. Optimum resistivity ranges from 0.5 to 500 MΩ.cm. Low resistivity promotes a good wraparound effect, but there may be back spray onto the operator if the booth is inadequately ventilated, especially when using the round spray.

Much lower resistivity (for example 0.1 MΩ.cm) will short circuit the high voltage and therefore prevent any wraparound effect. High resistivity (e.g. 1000 MΩ.cm) will significantly reduce the wraparound effect which will be greatly reduced. Paint resistivity can be easily checked using the SAMES AP 1000 resistivohmmeter.

8.1.3. Flash point

Use paints whose flash point is at least 5 °C higher than the ambient temperature.

9. Misuse of the Apparatus

The non-exhaustive list below describes some major misuses of a paint spraying device.



WARNING : Sames Technologies would like to remind users that the instructions below MUST be strictly complied with.

It is forbidden to install the control module in a potentially explosive atmosphere.
It is forbidden to subject the paint or air hose or spray gun power cable to excessive and repeated tension strain.
It is forbidden to disconnect the electrical connector in a potentially explosive atmosphere.
It is forbidden to leave air or paint hoses trailing on the floor or in areas where they are liable to be crushed or broken by industrial vehicles.
It is forbidden to use the Spraymium to spray a liquid other than a paint or clear coat.
It is forbidden to drop the spray gun or subjecting it to impacts.
It is forbidden to leave the spray gun on the ground.
It is forbidden to use the spray gun to handle or move the parts to be painted.
It is forbidden to leave the spray gun to soak in solvent or spraying it with solvent.
It is forbidden to spray solvent before switching off the control module.

It is essential to connect the control module ground terminal to the paint apparatus ground terminal.
It is essential to tighten the two safety screws on the electrical connector.
It is essential to engage the trigger safety after using the spray gun.

10. Maintenance

10.1. Preventive maintenance table

Sub-assembly	Description	Part number	Qty	Minimum replacement frequency
Air distributor	Lip seal	J3TPRF125	1	12 months
	O-ring	J3STKL102	4	6 months
	O-ring	J3STKL121	1	6 months
SX Tip	O-ring	129500260	1	3 months
Air cap adapter (SX)	O-ring	160000065	1	3 months
	O-ring	J2FENV288	1	12 months
	O-ring (seat)	129629922	1	3 months
Air cap adapter (SV/SSV/SP)	O-ring	J2FENV094	1	3 months
Barrel	Seal cartridge (*)	910005953	1	6 months or 500.000 operations (**)
	O-ring (seal cartridge)	J3STKL078	1	3 months
	O-ring (seal cartridge)	160000101	1	3 months
	O-ring	J3STKL028	1	3 months
	Anti-extrusion ring	900005980	1	3 months
Handle	O-ring (electrical connector)	160000041	1	6 months
	O-ring (handle base)	160000067	1	12 months
	O-ring (air nipple)	J2FTCF018	1	6 months
		J3STKL018	1	6 months
	O-ring (pressure sensor seal)	160000068	1	12 months
	O-ring (handle/barrel air duct seal)	J3STKL082	2	12 months
Trigger	O-ring (*)	J3STKL082	2	6 months or 500.000 operations (**)
	Trigger axle (*)	900006130	2	12 mois
	Trigger bearing (*)	900006093	2	12 months
Rear body	Filter of pressure sensor	900006025	1	6 months or less if necessary



WARNING : Remove the air distributor everyday ([see § 10.4 page 39](#)), and check there is no paint or solvent deposit. If presence of paint or solvent, verify the parts marked with a star (*) in the board.

(**): As soon as one of both terms is reached.



WARNING : Before any maintenance work on the spray gun, always refer to the health and safety instructions ([see § 2 page 9](#)).

- Disconnect the control module from the power supply.
- Check that the air and paint circuits are not pressurised.
- Dump the paint circuit.

10.2. Electropneumatic coupling

- **Step 1:** Remove paint hose. Hold base still with a 14mm open-ended spanner and loosen the paint hose nut with a 17mm spanner.



Step 1

- **Step 2:** Unclip the 7/10 polyurethane air hose from the clip-in coupling.

Step 2



- **Step 3:** Remove the low voltage cable with a 3mm Allen key, unscrew the two captive screws from the electropneumatic coupling.

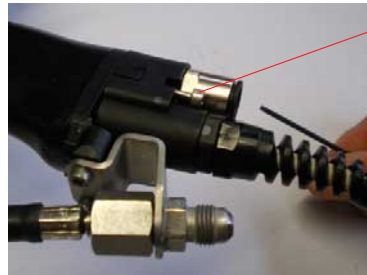

Captive screw

Step 3

- **Step 4:** Pull the electropneumatic coupling apart to disconnect.

Step 4



- **Step 5:** Loosen the coupling using a 16mm spanner and replace it.



Step 5

10.3. Paint Hoses

10.3.1. Paint hose - HR version

- **Step 1:** Hold the base in place near the handle, using a 14mm open-ended spanner and unscrew the swivel fitting with a 17mm spanner.



Step 1

- **Step 2:** Release the paint hose from base.



Step 2

- **Step 3:** Using the multipurpose spanner, unscrew the upper paint hose nut then manually loosen it, holding the lower nut in place.



Step 3

- **Step 4:** Check that the paint hose seal (P/N: J2FENV288) is in place (it can be lost in the event of leakage caused by inadequate tightening). If the seal has to be removed, it must be replaced with a new seal.

To reassemble, follow the steps in reverse order. Tighten manually the upper paint hose nut until it levels the reinforcement of the barrel.

10.3.2. Paint hose - LR version

- **Step 1:** Unscrew the paint hose stuffing box nut using a 24mm open-ended spanner.



Step 1

- **Step 2:** Unscrew the stuffing box locknut using a 27mm spanner, release the stuffing box from the bracket and release the hose.

Step 2



- **Step 3:** Loosen the upper paint hose nut using the multipurpose spanner.

Step 3



- **Step 4:** Unscrew the nut, whilst rotating the hose.

To reassemble, tighten the upper paint hose nut to a torque of 4.5 N.m ([see § 6 page 28](#)). Position the stuffing box locknut above the bracket and the stuffing box below, then insert the paint hose into the stuffing box. Tighten the stuffing box nut onto the bracket and screw the nut onto the stuffing box.

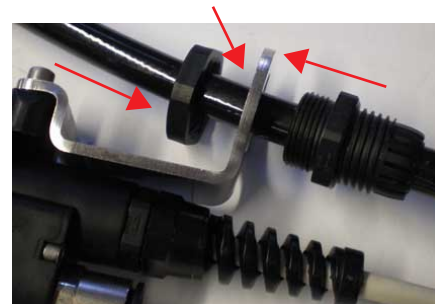

10.4. Air distributor

- **Step 1:** Unscrew the air distributor selector nut approximately 2 turns by hand and pull the selector backwards to release the foolproofing pin.

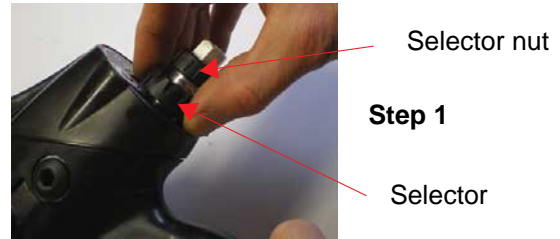

- **Step 2:** Unscrew the air distributor approximately 3 turns, holding the selector pressed against the nut, then pull the distributor and remove the rear body.

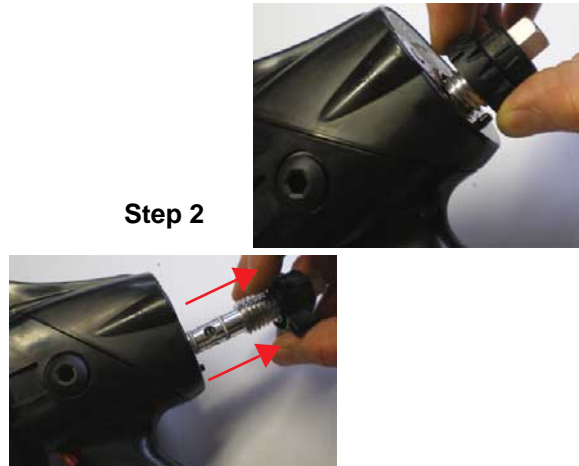

- **Step 3: Needle assembly.** Unscrew the nut and needle stem using a 5.5mm open-ended spanner.

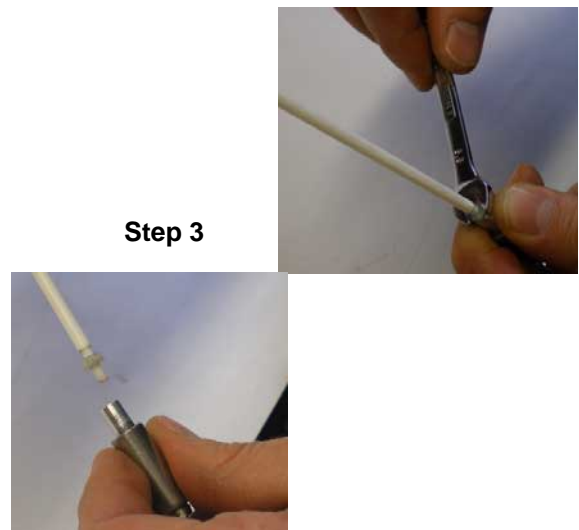

- **Step 4: Delay box.** Straighten the legs of the pin using flat nose pliers and remove pin from its housing. Dismantle the assembly.

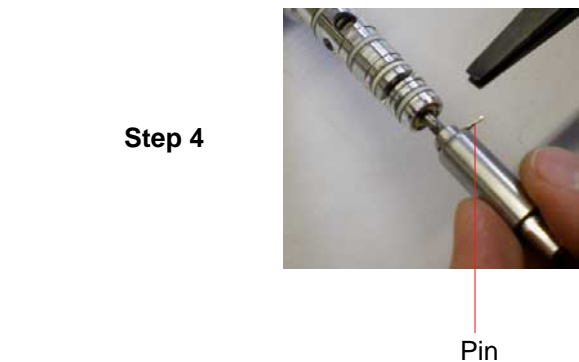

- **Step 5: Air valve.** Remove the air distributor knurled nut using a 13mm socket wrench, remove the spring, valve stem, then remove the valve, by pushing it backwards with flat nose pliers.



Step 5

- **Step 6: Air valve seal.** Unscrew the seal securing nut and remove the seal using a screwdriver.

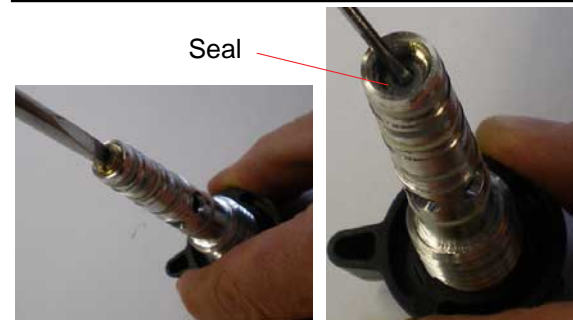

Step 6

To reassemble the air distributor assembly, follow the steps in reverse order.

- Position the lip seal in the air distributor (lip inwards) using a suitable tool (drift punch diam.: 3mm). This seal must be replaced every year.
- Reassemble the seal securing nut and screw in fully.
- Slip a new air valve onto the stem, on the opposite side to the groove, then insert the valve fully in.
- Place the valve stem in the air distributor, followed by the spring by having them beforehand coating with vaseline, then carefully turn the knurled nut and screw in fully using a 13mm socket wrench.
- Replace all air distributor seals every six months.
- Put the delay box in position, insert a new pin into the housing and bend back the legs either side of the delay box using flat nose pliers.
- Tighten the needle assembly according to the dimensions given in the illustration below.
 - 1 Unscrew the needle assembly locknut with a 5.5mm spanner.
 - 2 Adjust length by turning needle at a length about 189.5 mm or 192.5 mm according to the version.

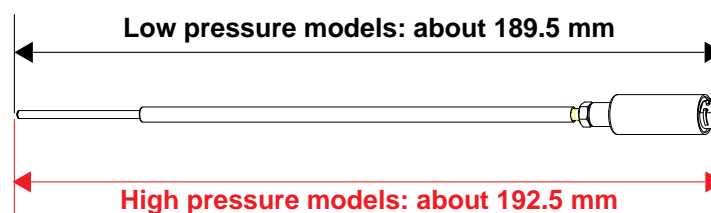

DES04112

- 3 Check the length of the needle using the tool (P/N # 900006126).
Install the needle assembly and position the index of the air distributor selector to the left (wide spray).
Put in place the air cap adapter on the barrel and make sure that the tool (P/N # 900006126) passes in the space between the air cap adapter and the barrel.
If the space is too important, shorten the needle; if the space is insufficient to place the tool, extend the needle. Proceed in this way until the space corresponds to the thickness of the tool.



Tool
(P/N # 900006126)

- 4 Block the needle assembly locknut, put a drop of varnish between the locknut and the needle.
- 5 Before re-installing the needle assembly, coat it with a fine layer of vaseline (air distributor, seal, delay box and needle).

10.5. Spray head assembly

10.5.1. Fan Spray Tip, HP version (SX)

- **Step 1:** Unscrew the air cap ring using the multipurpose spanner.



Step 1

- **Step 2:** Remove the air cap, followed by the tip.

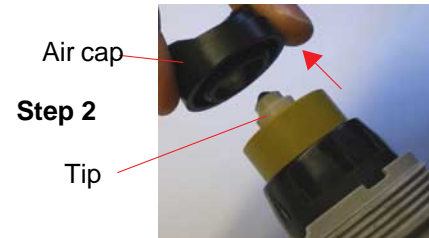

Step 2

- **Step 3:** Unscrew the air cap ring, following by the adapter using the multipurpose spanner, pulling them in a direction parallel to the barrel axis ([see § 10.5.1.1 page 43](#)).

- **Step 4:** Remove the tip seal using a 0.2mm screwdriver. This seal should be replaced every time the tip is disassembled.

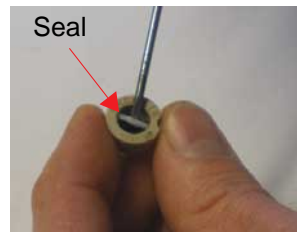

Step 4

To reassemble, follow the steps in reverse order.

- Put a new seal into the tip, and push fully in with a finger.
- Position the air cap adapter and nut, then tighten.



WARNING : At each reassembly of the tip, coat the seal (P/N # J2FENV288) of the air cap adapter with a fine layer of vaseline.

- Put the tip back in place, fully inserted, then reassemble the air cap, ensuring the air cap foolproofing pin is position on the tip.

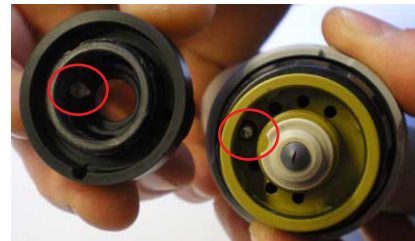

- Orientate the air cap vertically or horizontally depending on the required spraying direction.
- Tighten the air cap ring using the multipurpose spanner and lock in place.



WARNING : It is possible to orientate the fan air cap from the horizontal position to the vertical position:

- Unscrew the air cap ring using the multipurpose spanner.
- Turn the air cap to reach the required orientation.

10.5.1.1. Air cap adapter

[see § 13.5 page 67](#)

- **Step 1:** Remove the seals (P/N: 160000065 and J2FENV288) using a small screwdriver. The smaller of the two should be replaced every three months and the larger once a year. They should always be replaced whenever the device is disassembled. At each reassembly, coat the seals with vaseline.

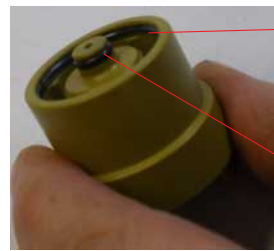

Seal
(P/N J2FENV288)

Step 1

Seal
(P/N 160000065)

- **Step 2: Replacing the seat:**
Unscrew the securing bush (P/N: 900000260) using a 2mm Phillip's screwdriver. The seat seal should always be replaced.

Step 2



To reassemble, follow the steps in reverse order:

- Coat the seat in vaseline and insert the seal.
- Place this assembly in the air cap adapter, with the seal inserted to the very bottom.
- Put the securing bush back in place then tighten to 1 N.m torque.

10.5.2. Round Spray Nozzle, LP version (SV)

- **Step 1:** Unscrew the air cap ring by hand, then remove air cap.
- **Step 2:** Unscrew the nozzle assembly and the air cap adapter nut using the multipurpose spanner.
- **Step 3:** Remove the air cap adapter, pulling it in a direction parallel to the barrel axis. Replace the seal every three months ([see § 13.5 page 67](#)).

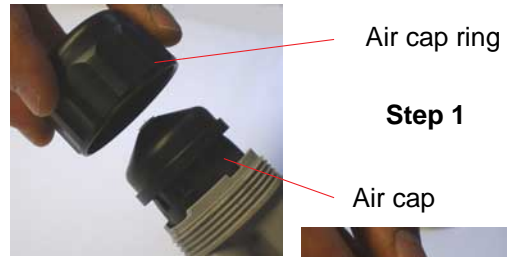

Step 1

Step 2



To reassemble, follow the steps in reverse order.

10.5.3. Fan Spray Nozzle, LP version (SP)

- **Step 1:** Unscrew the air cap ring by hand. Remove the air cap, followed by the swivel ring.
- **Step 2:** Unscrew the nozzle assembly and the air cap adapter nut using the multipurpose spanner.
- **Step 3:** Remove the air cap adapter, pulling it in a direction parallel to the barrel axis. Replace the adapter seal every three months ([see § 13.5 page 67](#)).



Step 1



Step 2

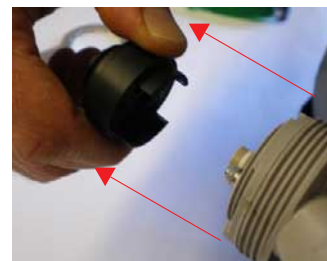

Step 3

To reassemble, follow the steps in reverse order.

10.6. Front of barrel

- **Step 1: Seal cartridge:** Extract cartridge from the barrel using the multipurpose spanner. The cartridge should be replaced every time it is disassembled.

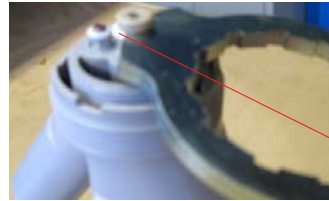

Step 1

White seal

If the O-ring at the front of the cartridge is to be replaced, removed it with a screwdriver, insert the new O-ring, ensuring it is positioned correctly, in front of the anti-extrusion ring.

When reassembling, ensure the cartridge is inserted in the correct orientation (white seal facing outwards). Push the cartridge until it clips into the barrel. Coat the white seal and the anti-extrusion ring with a fine layer of vaseline.

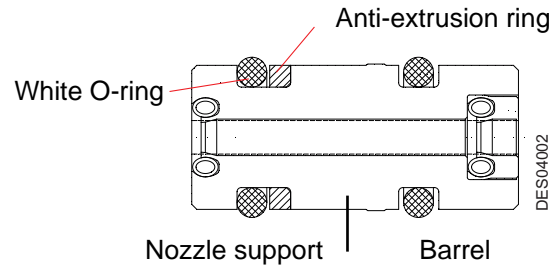

- **Step 2: Seal:** Replace the seal every three months. Remove the seal using a small screwdriver, taking care to avoid damaging the stainless steel part of the barrel.
Anti-extrusion ring: Replace the anti-extrusion ring every three months. Before reassembly, coat the seal and the anti-extrusion ring with vaseline.

Anti-extrusion ring

Seal

Step 2



Anti-extrusion ring



WARNING : When the anti-extrusion ring is re-installed, make sure that the slot is closed again in the correct directory.

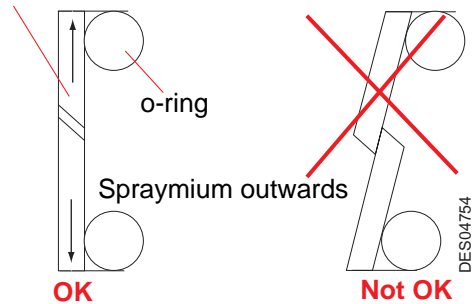

OK

Not OK

- **Step 3: HV contact:** Unscrew the HV contact using a 4mm socket wrench. The fibre washer should always be replaced whenever the device is disassembled. Replace the HV contact if necessary, then screw back into the barrel.



HV contact

10.7. Trigger

- **Step 1:** Release both sides of the trigger using a screwdriver.



Step 1

Bearing axles and o-rings:

Using nose pliers remove the bearing axles and with a small screwdriver remove the bearing o-rings. Replace the bearing o-rings (P/N # J3STKL082) every 500.000 operations of the trigger.

A counter in the Spraybox module prevents the user of the necessity of changing the bearing o-rings ([see § 3.2.7 page 24](#)).

Coat the bearing o-rings with a fine layer of vaseline before re-installing the bearing axles.



WARNING : To replace bearings, contact Sames Technologies.

Trigger reassembly or switching from a 2-finger trigger to a 4-finger trigger:

- Insert the trigger into one of the bearing axle from underneath, then slide the other side of the trigger into the other bearing axle.

When changing from a 2-finger trigger to a 4-finger trigger, the hose holder must also be changed.

- Loosen both screws with a 3mm Allen key, then replace the hose holder with support (P/N: 910006605 or 910006606).

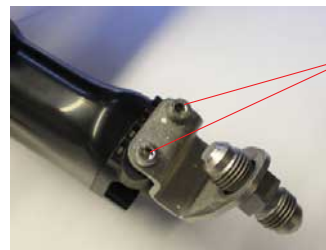

Securing screw

10.8. Rear body

- **Step 1:** Unscrew all three Phillip's screws (2 at rear and one at front).



Step 1



WARNING :

- **Step 2:** Carefully pull the rear body backwards along the same axis, otherwise the pressure sensor could get damaged.

Step 2



Seal

- **Step 3:** Cut the cable tie off the electrical connector with cutting pliers and disconnect.

Step 3

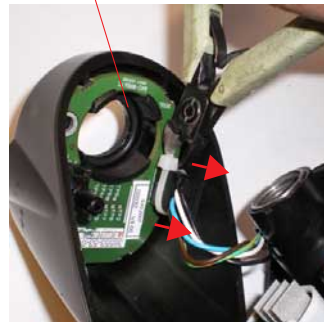

To reassemble, follow the steps in reverse order.

- Replace the rear body if necessary. Check that the O-ring is in place. Refit a new cable tie to the electrical connector.
- Check the handle/rear body sealing O-ring is in place. Position the rear body on the handle, replace the fibre washers.
- Tighten the front screw connecting the rear body and handle

Rear body tightening instructions.

(All versions with a serial number former than 090801)

If the rear body has never been dismantled: tighten half a turn with a screw driver (Phillips nb 2 tip), the three rear body fixing screws (A-B-C) which is equivalent to a tightening torque of 0,9 N.m.

If the rear body has been already dismantled: tighten to the same torque (0,9 N.m) and make sure that the o-ring between the handle and the rear body must be hardly visible (see illustration below).

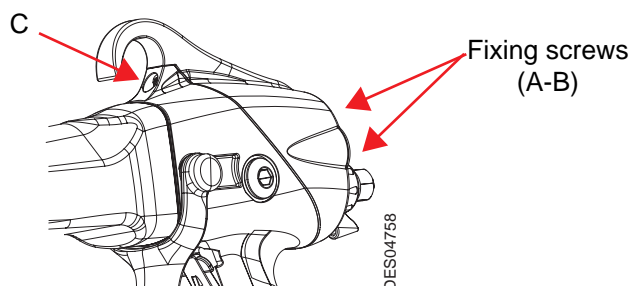

Replacement of the pressure sensor filter:

- Using nose pliers, remove the filter of the pressure sensor.
- Replace filter if it blocked. To install a new filter, place the filter in the opening of the sensor and apply it a light pressure with the thumb .



WARNING : During the reassembly, check the fibre washers (P/N # J4BRND039) are in place (on the screws).

10.9. High voltage cascade

- **Step 1:** Loosen both connecting screws on the cascade. Take care not to lose the serrated lock washers.



WARNING : The red wire connects to the + terminal of the cascade.

- **Step 2:** Swivel the cascade a quarter-turn to the left and remove it from the barrel.

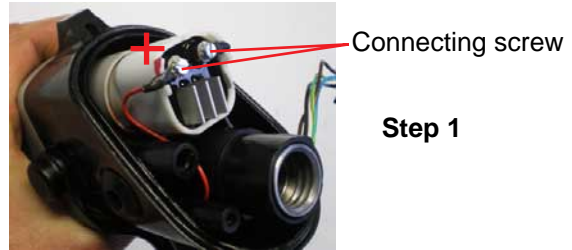

Step 2

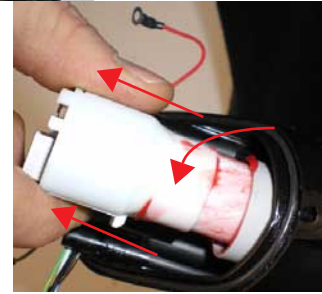

To reassemble, follow the steps in reverse order.

Replace the high-voltage cascade. **Coat the cascade with red dielectric lubricant** (P/N # H1GSYN037) then insert it into its housing (make sure the small pin is positioned on the right-hand side).

Push the cascade fully into the barrel, then rotate a quarter-turn to the right, in order to lock the pin behind the stop catch.

Connect both wires, position both serrated lock washers and tighten both screws.

10.10. Barrel / Handle

- **Step 1:** Undo both screws from the top of the high voltage cascade housing and both screws from the lower part of the handle using a 2mm Phillip's screwdriver.



Step 1

- **Step 2:** Remove the barrel / handle seal, using a small screwdriver. This seal should be replaced every year.



Step 2

To reassemble, follow the steps in reverse order.

- **Step 3:** Insert the 4 screws, without fibre washers, into their housing.
- **Step 4:** Position the barrel facing the four screws and tighten them to 1.5 N.m torque, whilst holding the assembly in place.

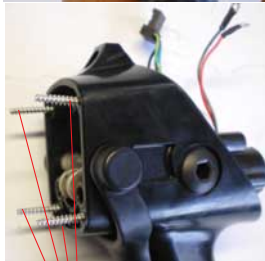

4 screws

Step 4



10.11. Handle

- **Step 1: Handle/barrel air duct seals.**
Remove both seals using a small screwdriver. They should always be replaced when the device is disassembled, or at least every year.
- **Step 2: Pressure sensor seal.**
Remove the seal using a small screwdriver. It should always be replaced when the device is disassembled, or at least every year.
- **Step 3: Handle base.**
Unscrew the air nipple using a 6mm Allen key. Replace the seals every 6 months.
- **Step 4:** Undo both K35 x 14 screws with a 2mm Phillip's screwdriver. Change the fibre washers each time the screws are removed.
- **Step 5:** Lift the base to access the handle base seal. This seal should be replaced every year.
- **Step 6:** Push the electrical connector to release it and remove from the base. Replace all air distributor seals every six months.



2 white
chemically-inert
seals

Step 1

Seal
Step 2

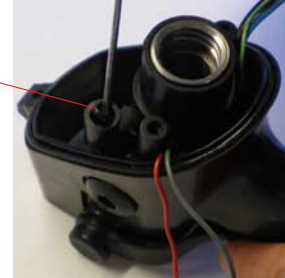

Air nipple

Step 3

Step 4



Step 5



Step 6

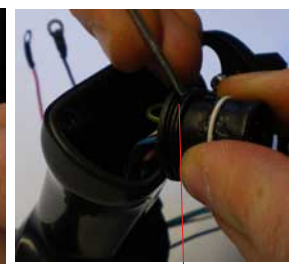

Seal

To reassemble, follow the steps in reverse order. Insert the connector pin back into the base foolproofing slot.

Coat the air nipple seals with dielectric lubricant.

Tighten the air nipple to 1.5 N.m torque.

Tighten the two K35 x 14 screws to 1.3 N.m torque.

10.12. Electric diagrams

10.12.1. Connection cable Spraymium / Spraybox

Plug side Spraymium

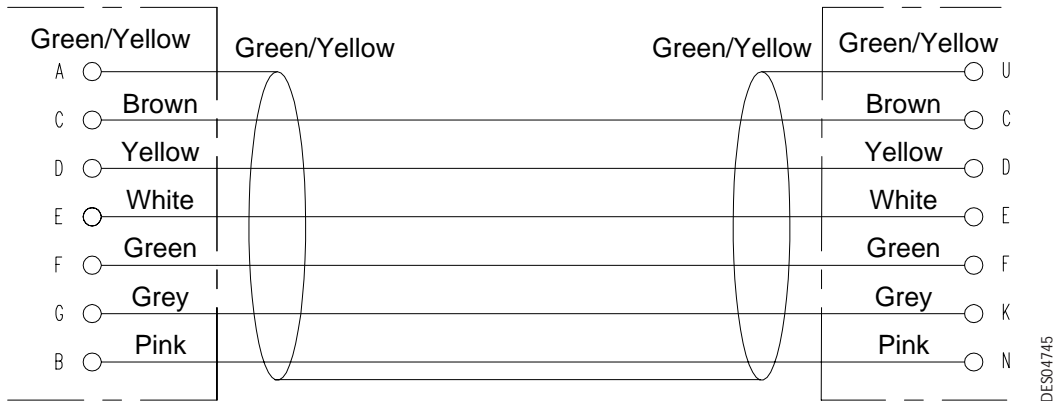

10.12.2. Spraybox trigger cable

R	Pink	Shunt between R and V
V		
H	Brown	Trigger authorization if H and S are connected
S	White	
G	Yellow	Trigger information (*)
F	Green	
U	Shield	Shield

Plug side Spraybox

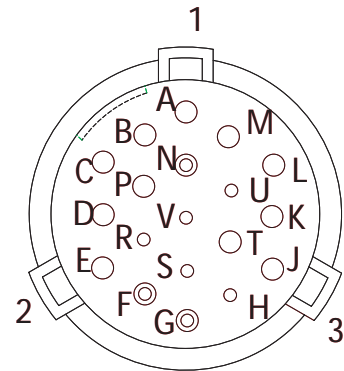

(*)

Switch "open": Spraymium trigger releases.

Switch "closed": Spraymium trigger activated.

Characteristics of the switch: 0.5 A maxi / 24 VAC/DC maxi.

10.12.3. Trigger connection

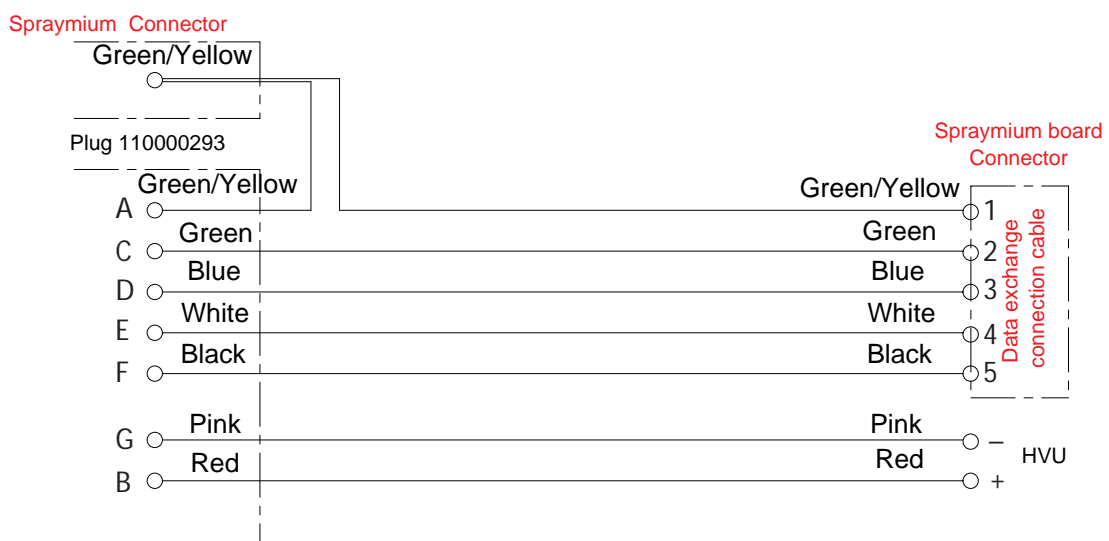

11. Cleaning

Always refer to the health and safety instructions before carrying out any work on the spray gun ([see § 2 page 9](#)).

11.1. Cleaning the product circuit

- Disconnect **Spraybox** control module.
- Install a bucket of solvent in place of the paint container.
- Open the recirculation valve to clean the pump.
- Close the recirculation valve and hold down the trigger until clean solvent comes out of the spray gun nozzle/tip.

11.2. Cleaning the spray gun

The spray gun must be cleaned immediately after use and at the end of the day, as with all paint guns. The cleaning procedure described below should be followed carefully:



WARNING : It is formally forbidden to plunge the Spraymium into solvent.



WARNING : Use an appropriate solvent: non-greasy, non-chlorinated and with a high resistivity.

- **Step 1**: Disconnect the **Spraybox** control module.
- **Step 2**: Depressurise the spray gun air circuit.
- **Step 3**: Drain the spray gun paint circuit and rinse with an appropriate solvent ([see § 2.4 page 10](#)).
- **Step 4**: Depressurise the spray gun paint circuit.
- **Step 5**: Engage the trigger safety catch then dry the spray gun air cap with a soft, dry, lint-free cloth.
- **Step 6**: Unscrew the spray gun air cap ring and remove the air cap ([see § 10.5 page 42](#)).
- **Step 7**: Clean the air cap with a solvent-dampened brush and then wipe dry.
- **Step 8**: Reassemble the air cap and ring.
- **Step 9**: Dry the compressed air spray gun (facing downwards) before restarting the **Spraybox** control module.



WARNING : Never disassemble the needle assembly when the paint hose contains paint or solvent.



WARNING : Never soak or immerse the spray gun in solvent.
When cleaning the nozzle/tip, always point the spray nozzle/tip towards the ground to prevent solvent or paint from flowing into the barrel ducts.



WARNING : After cleaning, the ducts and supply hose must be dried with compressed air to remove all traces of solvent.

11.2.1. Cleaning the tip, SX (120 and 200 bar) versions

- Unscrew the air cap ring using the multipurpose spanner.



WARNING : Remove the air cap, followed by the tip.

- Clean the tip using solvent and unblocking needles (Ref.: 000094000).
- Clean the paint circuit ([see § 11.1 page 52](#)).
- Put in place the tip on the air cap adapter, orientate the air cap and tighten the air cap ring using the multipurpose spanner.

Tip

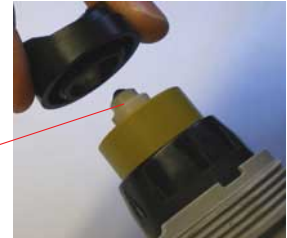

11.3. Waste disposal

Waste generated by use of the apparatus (spent solvent, unused paint, residue, dirty cloths, paint booth slurry, water-wash spray booth run-off, used dry filters, ventilation air etc.) must be removed, transported and disposed of in strict compliance with the applicable local regulations.

12. Troubleshooting Guide

Faults	Possible causes	Remedies
Irregular paint spray	Air in paint circuit	Dump the paint circuit
	Paint flow too low	Increase pressure in pump or pressure tank
	Impurities in circuit	Check filter, then drain circuit
	Paint tank empty (or nearly)	Refill paint tank
Paint not fluid enough when leaving spray gun	Blocked nozzle/tip	Clean nozzle/tip
	Needle does not retract	Check needle assembly
	Clogged filter	Clean filter
	Insufficient pump pressure	Check pump
	Paint viscosity too high	Check paint viscosity
	Dia 2.5mm paint hose clogged	Unblock or replace paint hose
	Needle assembly set to wrong length	
Paint flows out continuously	Needle is obstructed and cannot close	Remove nozzle/tip holder and clean holder and seat. Clean needle tip
	Worn needle	Replace needle and, if necessary, the nozzle/tip holder
	Nozzle/tip holder damaged	Replace nozzle/tip holder
Paint comes out of air cap air holes	Nozzle/tip insufficiently tightened against seat	Tighten nozzle/tip
	Damaged cartridge	Replace cartridge
	Damaged paint seal	Replace seal
Poor spraying quality	Nozzle/tip partially blocked	Clean nozzle/tip
	Paint flow too weak	Increase paint flow
	Viscosity too high	Dilute paint
	Insufficient air for spraying	Increase air pressure
	Paint flow too high	Reduce paint flow
Orange peel effect	Solvents evaporating too quickly	Use heavier solvents
	Paint droplets too large	Increase spraying distance
		Dilute paint
		Increase spraying air pressure
		Decrease nozzle/tip size

Faults	Possible causes	Remedies
Paint running	Solvents evaporating too slowly	Use lighter solvents
	Spraying applied too slowly	Reduce paint flow
		Increase spraying air pressure
		Reduce the electrostatic effect
Paint spray overloaded in middle	Paint flow too high	Reduce paint flow
		Increase air pressure
	Nozzle/tip too large	Use a smaller nozzle/tip
	Paint viscosity too great	Dilute paint
	Air holes partially blocked	Clean spray head
Insufficient electrostatic effect	High voltage power not on (see display on control module)	Increase spraying air pressure to set off the trigger (> 0.14 bar)
	High voltage power insufficient	Increase high voltage power
	Distance between spray head and part too great	Check Spraymium output voltage
		Spray from between 200 and 300 mm away
	Part not grounded	Clean hooks. Check grounding connection of parts conveyor
	Excessive ventilation	Reduce paint booth air extraction rate, ensuring the applicable regulations are still complied with
	Spraying air pressure too high	Reduce spraying air pressure
	Paint flow too high	Reduce paint flow
	Product resistivity too high	Reduce product resistivity to obtain $\rho < 500\text{M}\Omega.\text{cm}$
	Generator short circuit: - external	Clean outside of the spray gun with a non-conductive solvent ($\rho > 15 \text{M}\Omega.\text{cm}$)
		Use a new, clean and dry case
	Generator short circuit: - via needle assembly	Replace cartridge and needle
Generator short circuit: - via air channels	Clean the air channels of the barrel	
Generator short circuit: - via product hose	Increase the resistivity of paint so that $\rho > 5 \text{M}\Omega.\text{cm}$	
Operator gets electric shocks when touching the part	Part not grounded or poorly grounded	
Excess internal pressure warning displayed	Internal air leak inside spray gun: - damaged air distributor seal - Damaged air supply nipple seals	Replace air distributor seals.
		Replace air nipple seals.

13. Spare Parts

13.1. Spraymium spray guns for high resistivity (HR) solvent paint $\rho > 5M\Omega.cm$

13.1.1. Low Pressure Spray Gun Models (LP)

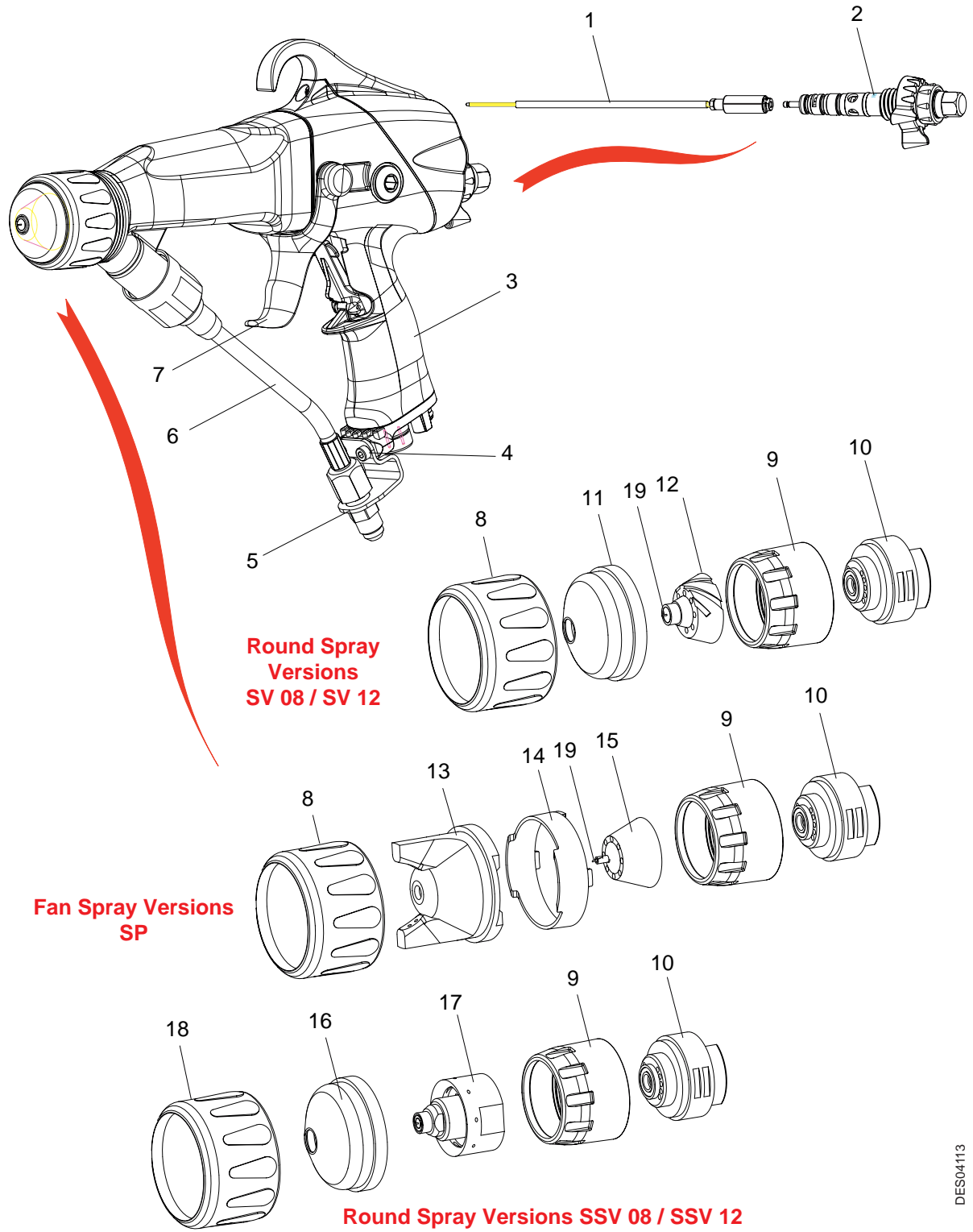

DES04113

Item	Part number	Description	Qty	Unit of sale	Spare Part Level
	910004881	Spraymium SV08 LP HR Round Spray	1	1	-
1	910000405	Low Pressure Needle Assembly (see § 13.7 page 69)	1	1	3
2	910000524	SV-SSV Air distributor (see § 13.8 page 70)	1	1	3
3	-	HR- LR common core (see § 13.4 page 64)	1	-	-
4	X4FVSY118	Stainless steel Allen screws M4 X 10	2	1	1
5	910003846	LP HR - 2D Product hose holder	1	1	3
6	910003931	Short product hose D: 2.5 mm	1	1	1
	J2FENV288	O-ring (FEP-Viton)	1	1	1
7	900000176	2-finger trigger	1	1	3
8	900003774	SV/SP air cap ring	1	1	3
9	900000320	LP/HP air cap nut	1	1	3
10	910003617	SV/SP/SSV air cap adapter (see § 13.5.1 page 67)	1	1	1
11	1406310	V08 Air cap	1	1	1
12	1406309	SV08 Nozzle assembly	1	1	1
19	446028	Electrode	1	5	1
Not shown					
	050123306	M1/2 JIC adapter - F3/8NPS paint hose	1	1	3

Item	Part number	Description	Qty	Unit of sale	Spare Part Level (*)
	910004887	Spraymium SV12 LP HR Round Spray	1	1	-
1	910000405	Low Pressure Needle Assembly (see § 13.7 page 69)	1	1	3
2	910000524	SV-SSV Air distributor (see § 13.8 page 70))	1	1	3
3	-	HR- LR common core(see § 13.4 page 64)	1	-	-
4	X4FVSY118	Stainless steel Allen screws M4 X 10	2	1	1
5	910003846	LP HR - 2D Product hose holder	1	1	3
6	910003931	Short product hose D: 2.5 mm	1	1	1
	J2FENV288	O-ring (FEP-Viton)	1	1	1
7	900000176	2-finger trigger	1	1	3
8	900003774	SV/SP air cap ring	1	1	3
9	900000320	LP/HP air cap nut	1	1	3
10	910003617	SV/SP/SSV air cap adapter (see § 13.5.1 page 67)	1	1	1
11	1406507	V12 Air cap	1	1	1
12	1406506	SV12 Nozzle assembly	1	1	1
19	446028	Electrode	1	5	1
Not shown					
	050123306	M1/2 JIC adapter - F3/8NPS paint hose	1	1	3

Spare Part Level:

Level 1: Standard preventive maintenance.

Level 2: Corrective maintenance.

Level 3: Exceptional maintenance.

For the various options: [see § 13.12 page 75.](#)

Item	Part number	Description	Qty	Unit of sale	Spare Part Level
	910004885	Spraymium SSV08 LP HR Round Spray	1	1	-
1	910000405	Low Pressure Needle Assembly (see § 13.7 page 69)	1	1	3
2	910000524	SV-SSV Air distributor (see § 13.8 page 70)	1	1	3
3	-	HR- LR common core (see § 13.4 page 64)	1	-	-
4	X4FVSY118	Stainless steel Allen screws M4 X 10	2	1	1
5	910003846	LP HR - 2D Product hose holder	1	1	3
6	910003931	Short product hose D: 2.5 mm	1	1	1
	J2FENV288	O-ring (FEP-Viton)	1	1	1
7	900000176	2-finger trigger	1	1	3
9	900000320	LP/HP air cap nut	1	1	3
10	910003617	SV/SP/SSV air cap adapter (see § 13.5.1 page 67)	1	1	1
16	430540	SSV08 Air cap	1	1	1
17	910003847	SSV08 Nozzle assembly (see § 13.6.1 page 68)	1	1	1
18	1404770	SSV Air cap ring	1	1	3
Not shown					
	050123306	M1/2 JIC adapter - F3/8NPS paint hose	1	1	3

Item	Part number	Description	Qty	Unit of sale	Spare Part Level
	910004883	Spraymium SSV12 LP HR Round Spray	1	1	-
1	910000405	Low Pressure Needle Assembly (see § 13.7 page 69)	1	1	3
2	910000524	SV-SSV Air distributor (see § 13.8 page 70)	1	1	3
3	-	HR- LR common core (see § 13.4 page 64)	1	-	-
4	X4FVSY118	Stainless steel Allen screws M4 X 10	2	1	1
5	910003846	LP HR - 2D Product hose holder	1	1	3
6	910003931	Short product hose D: 2.5 mm	1	1	1
	J2FENV288	O-ring (FEP-Viton)	1	1	1
7	900000176	2-finger trigger	1	1	3
9	900000320	LP/HP air cap nut	1	1	3
10	910003617	SV/SP/SSV air cap adapter (see § 13.5.1 page 67)	1	1	1
16	430179	SSV12 Air cap	1	1	1
17	910003920	SSV12 Nozzle assembly (see § 13.6.1 page 68)	1	1	1
18	1404770	SSV Air cap ring	1	1	3
Not shown					
	050123306	M1/2 JIC adapter - F3/8NPS paint hose	1	1	3

Spare Part Level:

Level 1: Standard preventive maintenance.

Level 2: Corrective maintenance.

Level 3: Exceptional maintenance.

For the various options: [see § 13.12 page 75.](#)

Item	Part number	Description	Qty	Unit of sale	Spare Part Level
	910004884	Spraymium SP LP HR Fan Spray	1	1	-
1	910000405	Low Pressure Needle Assembly (see § 13.7 page 69)	1	1	3
2	910000404	SP Air distributor (see § 13.8 page 70))	1	1	3
3	-	HR- LR common core (see § 13.4 page 64)	1	-	-
4	X4FVSY118	Stainless steel Allen screws M4 X 10	2	1	1
5	910003846	LP HR - 2D Product hose holder	1	1	3
6	910003931	Short product hose D: 2.5 mm	1	1	1
	J2FENV288	O-ring (FEP-Viton)	1	1	1
7	900000176	2-finger trigger	1	1	3
8	900003774	SV/SP air cap ring	1	1	3
9	900000320	LP/HP air cap nut	1	1	3
10	910003617	SV/SP/SSV air cap adapter (see § 13.5.1 page 67)	1	1	1
13	737549	SP Air cap	1	1	1
14	900000183	SP Swivel ring	1	1	2
15	1406402	SP Nozzle assembly	1	1	1
19	446028	Electrode	1	5	1
Not shown					
	050123306	M1/2 JIC adapter - F3/8NPS paint hose	1	1	3

Level 1: Standard preventive maintenance.

Level 2: Corrective maintenance.

Level 3: Exceptional maintenance.

For the various options: [see § 13.12 page 75.](#)

13.1.2. High Pressure Models

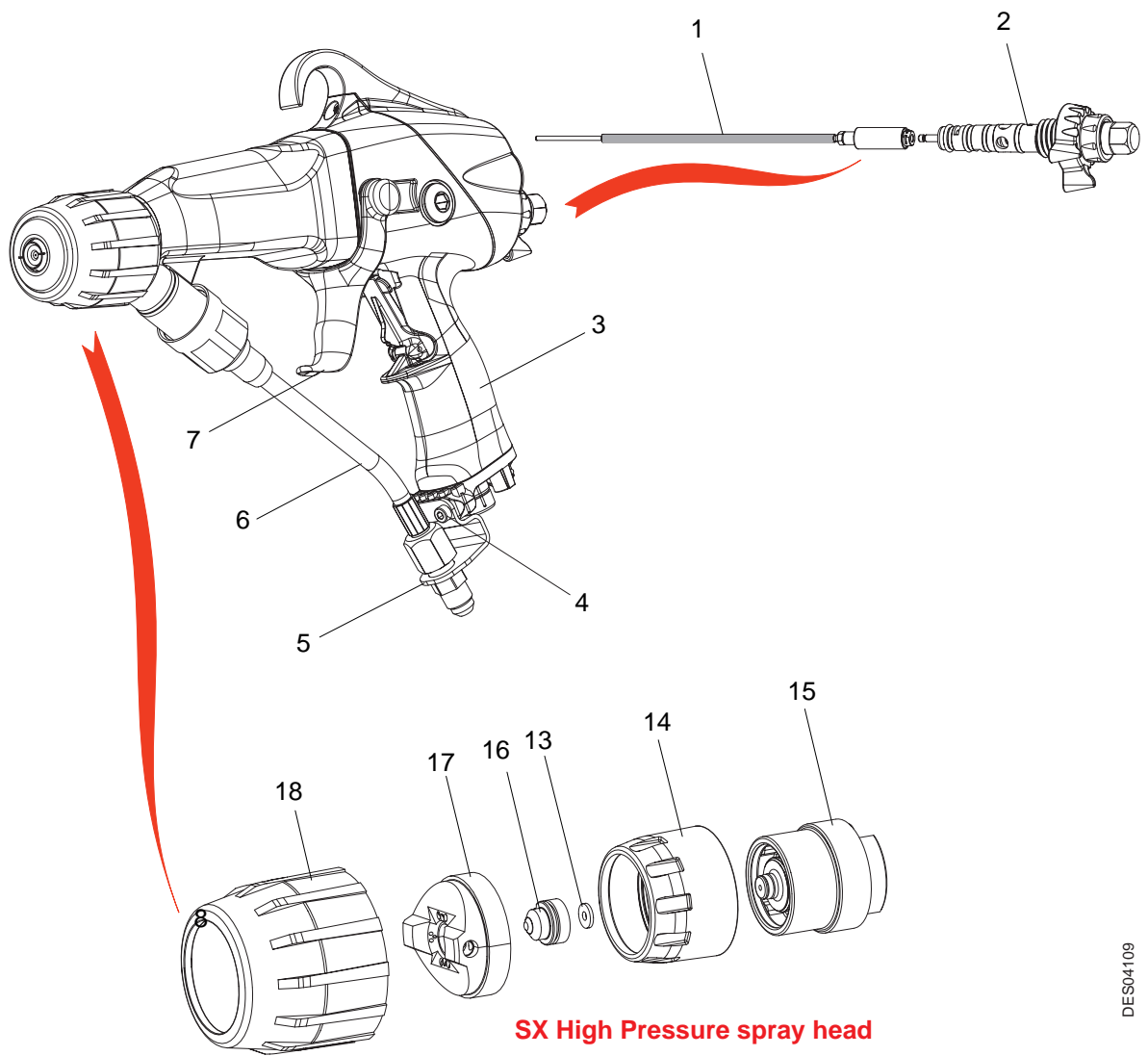

Item	Part number	Description	Qty	Unit of sale	Spare Part Level
	910004888	Spraymium SX200 HP HR Fan Spray	1	1	-
1	910002031	High Pressure Needle Assembly (see § 13.7 page 69)	1	1	3
2	910004753	SX Air distributor (see § 13.8 page 70)	1	1	3
3	-	HR- LR common core (see § 13.4 page 64)	1	-	-
4	X4FVSY118	Stainless steel Allen screws M4 X 10	2	1	1
5	910005988	HP HR - 2D Product hose holder	1	1	3
6	910003931	Short product hose D: 2.5 mm	1	1	1
	J2FENV288	O-ring (FEP-Viton)	1	1	1
7	900000176	2-finger trigger	1	1	3
13	129500260	Flat seal	1	10	1
14	900000320	LP/HP air cap nut	1	1	3
15	910003441	SC/SX air cap adapter (see § 13.5.2 page 67)	1	1	1
16	134509139	SX 09139 Tip	1	1	1
17	132500410	X14 air cap assembly	1	1	1
18	900004323	SX Air cap ring	1	1	3

Item	Part number	Description	Qty	Unit of sale	Spare Part Level
	910007016	Spraymium SX120 HP HR Fan Spray	1	1	-
1	910007035	SX 120 High Pressure Needle Assembly (see § 13.7 page 69)	1	1	3
2	910007034	SX 120 Air distributor (see § 13.8 page 70)	1	1	3
3	-	HR- LR common core (see § 13.4 page 64)	1	-	-
4	X4FVSY118	Stainless steel Allen screws M4 X 10	2	1	1
5	910007084	HP HR - 2D Product hose holder	1	1	3
6	910003931	Short product hose D: 2.5 mm	1	1	1
	J2FENV288	O-ring (FEP-Viton)	1	1	1
7	900000176	2-finger trigger	1	1	3
13	129500260	Flat seal	1	10	1
14	900000320	LP/HP air cap nut	1	1	3
15	910003441	SC/SX air cap adapter (see § 13.5.2 page 67)	1	1	1
16	134509139	SX 09139 Tip	1	1	1
17	132500410	X14 air cap assembly	1	1	1
18	900004323	SX Air cap ring	1	1	3

Spare Part Level

Level 1: Standard preventive maintenance.

Level 2: Corrective maintenance.

Level 3: Exceptional maintenance.

For the various options: [see § 13.13 page 77.](#)

13.2. Spraymium Low Pressure spray guns for solvent paint $0.5 \text{ M}\Omega\cdot\text{cm} < \rho < 500 \text{ M}\Omega\cdot\text{cm}$



WARNING : Spraymium Low Pressure low resistivity spray guns comprise the same components, with the exception of the hose holders. The short product hose is replaced by the 10m-long LR - HP LP product hose.

Item	Part number	Description	Qty	Unit of sale	Spare Part Level
	910005774	Spraymium SV08 LP LR Round Spray	1	1	-
	910006605	LR-W product hose holder	1	1	3

Item	Part number	Description	Qty	Unit of sale	Spare Part Level
	910005780	Spraymium SV12 LP LR Round Spray	1	1	-
	910006605	LR-W product hose holder	1	1	3

Item	Part number	Description	Qty	Unit of sale	Spare Part Level
	910005778	Spraymium SSV08 LP LR Round Spray	1	1	-
	910006605	LR-W product hose holder	1	1	3

Item	Part number	Description	Qty	Unit of sale	Spare Part Level
	910005776	Spraymium SSV12 LP LR Round Spray	1	1	-
	910006605	LR-W product hose holder	1	1	3

Item	Part number	Description	Qty	Unit of sale	Spare Part Level
	910005777	Spraymium SP LP LR Fan Spray	1	1	-
	910006605	LR-W product hose holder	1	1	3

13.3. Spraymium High Pressure spray guns for solvent paint $0.5 \text{ M}\Omega.\text{cm} < \rho < 500\text{M}\Omega.\text{cm}$



WARNING : Spraymium High Pressure low resistivity spray guns comprise the same components, with the exception of the hose holders. The short product hose is replaced by the 10m-long LR - HP LP product hose.

Item	Part number	Description	Qty	Unit of sale	Spare Part Level
	910005781	Spraymium SX200 HP LR Fan Spray	1	1	-
	910006606	LR-W product hose holder	1	1	3

Item	Part number	Description	Qty	Unit of sale	Spare Part Level
	910007017	Spraymium SX120 HP LR Fan Spray	1	1	-
	910007090	LR-HP 120 product hose holder	1	1	3

13.4. Common core

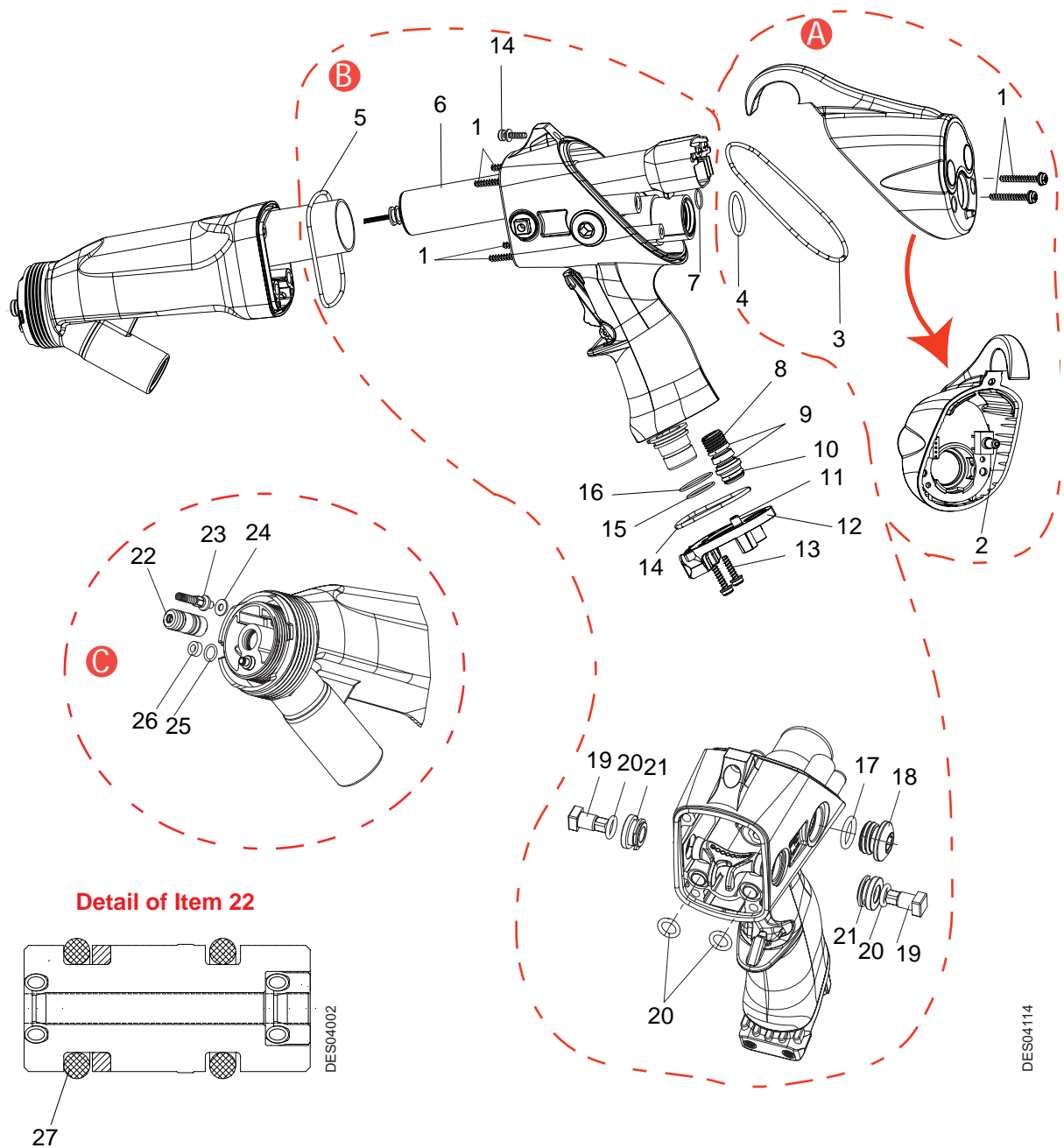

DES04114

Item	Part number	Description	Qty	Unit of sale	Spare Part Level (*)
	-	Common core	1	-	-
A	910003614	Rear body assembly with circuit board and clamp	1	1	3
1	250000036	K35 x 25 stainless steel screws	6	1	1
	J4BRND039	Fibre washer	3	1	1
2	900006025	Pressure sensor filter	1	10	1
3	160000081	O-ring	1	1	1
4	160000082	O-ring	1	1	1
	129500200	High voltage cascade (not included in item B)	1	1	3
6	X2BVKY043	Galvanized steel screws C M 2.5 / 6	2	1	3
	X2BDVX425	Serrated lock washer AZ 2.5	2	1	3
	129400915	Cascade seal	2	10	3
B	910008660	Handle assembly	1	1	3
5	160000066	O-ring - viton	1	1	2
7	160000068	O-ring	1	1	1
8	910006118	Air nipple assembly	1	1	3
9	J2FTCF018	O-ring - viton (included in item 8)	2	2	1
10	J3STKL018	Chemically inert O-ring (included in item 8)	1	1	1
11	X3GJCP004	K25 x 6 stainless steel screws for grounding connection	1	1	3
12	900000195	Handle base	1	1	3
13	250000037	K35 x 14 stainless steel screws	3	1	1
	J4BRND039	Fibre washer	5	1	1
14	160000067	O-ring - viton	1	1	1
15	160000040	O-ring - viton	1	1	1
16	160000041	Chemically-inert O-ring	1	1	1
17	J2FTDF133	O-ring - viton	1	1	3
18	900000180	Side plug	1	1	3
19	900006130	Trigger axle	2	1	3
20	J3STKL082	Chemically-inert O-ring	4	1	3
21	900006093	Trigger bearing	2	1	3
	J3STKL102	Chemically-inert O-ring	2	1	3
C	910003623	Barrel assembly	1	1	3
22	910005953	Seal cartridge	1	1	1
23	910004269	High voltage contact	1	1	2
24	J4BRND039	Fibre washer	1	1	1
25	900005980	Anti-extrusion ring	1	1	1
26	J3STKL028	Chemically-inert O-ring	1	1	1
27	J3STKL078	White chemically-inert O-ring (included in item 22)	1	1	1

(*)

Level 1: Standard preventive maintenance.

Level 2: Corrective maintenance.

Level 3: Exceptional maintenance.

13.4.1. Seal kits associated with Common core

Part number	Description	Qty	Unit of sale	Spare Part Level
910006459	Spraymium handle seal kit	1	1	1
see § 13.4 page 64 item 5	O-ring - Viton	1	-	-
see § 13.4 page 64 item 3	O-ring	1	-	-
see § 13.4 page 64 item 7	O-ring	1	-	-
see § 13.4 page 64 item 4	O-ring	1	-	-
see § 13.4 page 64 item 9	O-ring - Viton	2	-	-
see § 13.4 page 64 item 10	Chemically-inert O-ring	1	-	-
see § 13.4 page 64 item 14	O-ring - Viton	1	-	-
see § 13.4 page 64 item 15	O-ring - Viton	1	-	-
see § 13.4 page 64 item 16	Chemically-inert O-ring	1	-	-
see § 13.4 page 64 item 21	Chemically-inert O-ring	2	-	-
see § 13.4 page 64 item 20	Chemically-inert O-ring	4	-	-
see § 13.4 page 64 item 17	O-ring - Viton	1	-	-

Part number	Description	Qty	Unit of sale	Spare Part Level
910006460	LP spray head seal kit	1	1	1
see § 13.5.1 page 67 item 1	O-ring (FEP Viton)	1	-	-
see § 13.4 page 64 item 25	Anti-extrusion ring	1	-	-
see § 13.4 page 64 item 26	Chemically-inert O-ring	1	-	-
see § 13.4 page 64 item 27	Chemically-inert O-ring	1	-	-

Part number	Description	Qty	Unit of sale	Spare Part Level
910006476	HP spray head seal kit	1	1	1
see § 13.5.2 page 67 item 1	HP tip seat seal	1	-	-
see § 13.5.2 page 67 item 4	O-ring (FEP Viton)	1	-	-
see § 13.5.2 page 67 item 5	Chemically-inert O-ring	1	-	-
see § 13.1.2 page 60 item 13	Flat seal	1	-	-
see § 13.4 page 64 item 25	Anti-extrusion ring	1	-	-
see § 13.4 page 64 item 26	Chemically-inert O-ring	1	-	-
see § 13.4 page 64 item 27	Chemically-inert O-ring	1	-	-

Part number	Description	Qty	Unit of sale	Spare Part Level
910006477	Cascade seal kit	1	1	1
see § 13.4 page 64 item 6	O-ring	1	-	-
see § 13.4 page 64 item 6	O-ring	2	-	-

13.5. Air cap adapter assemblies

13.5.1. For low pressure models

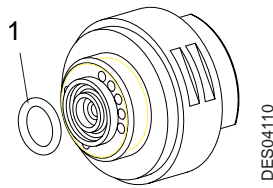

Item	Part number	Description	Qty	Unit of sale	Spare Part Level
	910003617	Air cap adapter - LP Models	1	1	1
1	J2FENV094	O-ring (FEP Viton)	1	1	1

13.5.2. For high pressure models

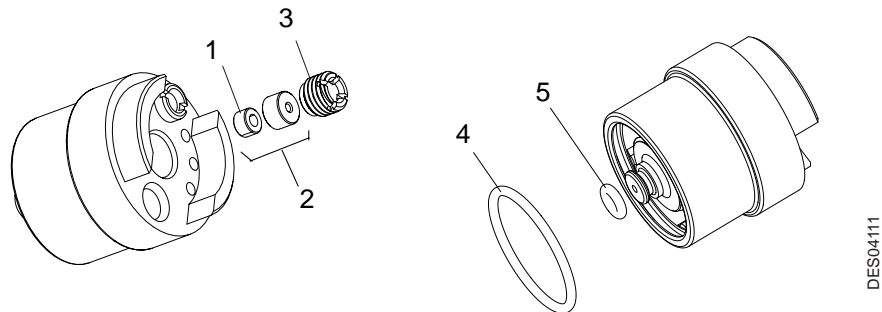

Item	Part number	Description	Qty	Unit of sale	Spare Part Level
	910003441	Air cap adapter - HP Models	1	1	1
1	129629922	HP tip seat seal (10-seal pack)	1	1	1
2	129670049	HP tip seat (2 equipped seat pack)	1	1	1
	129629922	HP tip seat seal	1	1	1
3	900002060	Seat securing bush	1	1	3
4	J2FENV288	O-ring (FEP Viton)	1	1	1
5	160000065	Chemically-inert O-ring	1	1	1

13.6. Nozzle assemblies - LP Models

13.6.1. SSV Nozzle assemblies

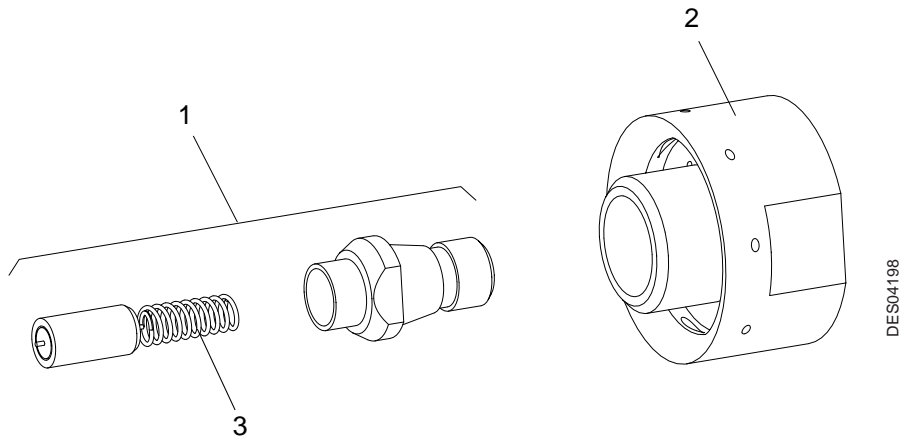

Item	Part number	Description	Qty	Unit of sale	Spare Part Level
	910003847	SSV 08 Nozzle assemblies	1	1	1
1	455235	Injector - Calibre 8	1	5	1
2	1305211	Vortex Nozzle	1	1	1
3	448110	Electrode (included in item1)	1	10	1

Item	Part number	Description	Qty	Unit of sale	Spare Part Level
	910003920	SSV 12 Nozzle assemblies	1	1	1
1	455236	Injector - Calibre 12	1	5	1
2	1305211	Vortex Nozzle	1	1	1
3	448110	Electrode (included in item1)	1	10	1

13.7. Needle assemblies

13.7.1. For low pressure models

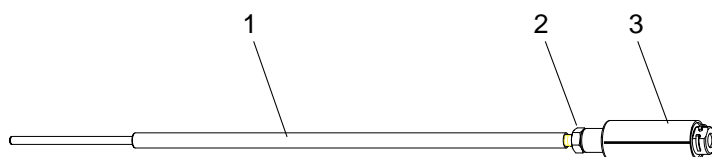

DES04112



WARNING : The needle assembly length (1 + 2 + 3) is about 189.5 mm.

Item	Part number	Description	Qty	Unit of sale	Spare Part Level
	910000405	Needle assembly for LP models	1	1	3
1	910000403	LP Needle	1	1	1
2	X9NEHU003	H M3 U Fibre-glass nylon nut	1	1	1
3	910003255	Delay box for SV/SSV/SP versions	1	1	3
	X4CGFN001	Stainless steel Cotter pin	1	1	3

13.7.2. For high pressure models

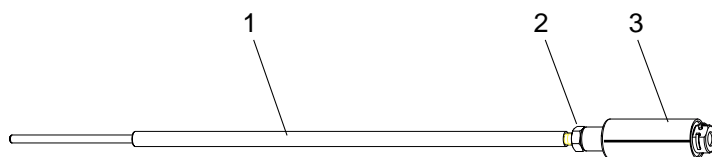

ES04112



WARNING : The needle assembly length (1 + 2 + 3) is about 192.5 mm.

Item	Part number	Description	Qty	Unit of sale	Spare Part Level
	910002031	Needle assembly for SX 200 models	1	1	3
1	910002030	HP Needle	1	1	1
2	X9NEHU003	H M3 U Fibre-glass nylon nut	1	1	1
3	910000402	Delay box for SX 200 versions	1	1	3
	X4CGFN001	Stainless steel Cotter pin	1	1	3

Item	Part number	Description	Qty	Unit of sale	Spare Part Level
	910007035	Needle assembly for SX 120 models	1	1	3
1	910002030	HP Needle	1	1	1
2	X9NEHU003	H M3 U Fibre-glass nylon nut	1	1	1
3	910006943	Delay box for SX 120 versions	1	1	3
	X4CGFN001	Stainless steel Cotter pin	1	1	3

13.8. Air Distributor Assemblies

13.8.1. For low pressure models

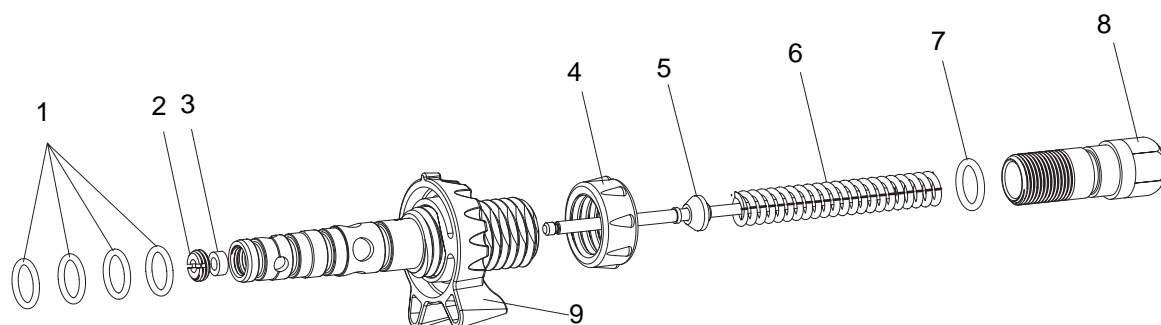

DES04107

Item	Part number	Description	Qty	Unit of sale	Spare Part Level (*)
	910000404	Air Distributor Assembly for SP	1	1	3
	910000524	Air Distributor Assembly for SV/SSV versions	1	1	3
1	J3STKL102	Chemically-inert O-ring	4	1	1
2	900000231	Air distributor stuffing box	1	1	3
3	J3TPRF125	Lip seal	1	1	1
4	548024	Air distributor nut	1	1	3
5	900003919	Air valve	1	1	2
6	900002499	Compression spring for SP, SV/SSV LP versions	1	1	3
7	J3STKL121	Chemically-inert O-ring	1	1	1
8	900000310	Knurled nut for SP, SV/SSV LP versions	1	1	3
9	900000179	Selector	1	1	3

(*)

Level 1: Standard preventive maintenance.

Level 2: Corrective maintenance.

Level 3: Exceptional maintenance.

Part number	Description	Qty	Unit of sale	Spare Part Level (*)
910006119	Air distributor seals kit - All versions	1	1	1
J3TPRF125	Lip seal	1	1	1
J3STKL102	Chemically-inert O-ring	4	1	1
J3STKL121	Chemically-inert O-ring	1	1	1

13.8.2. For high pressure models

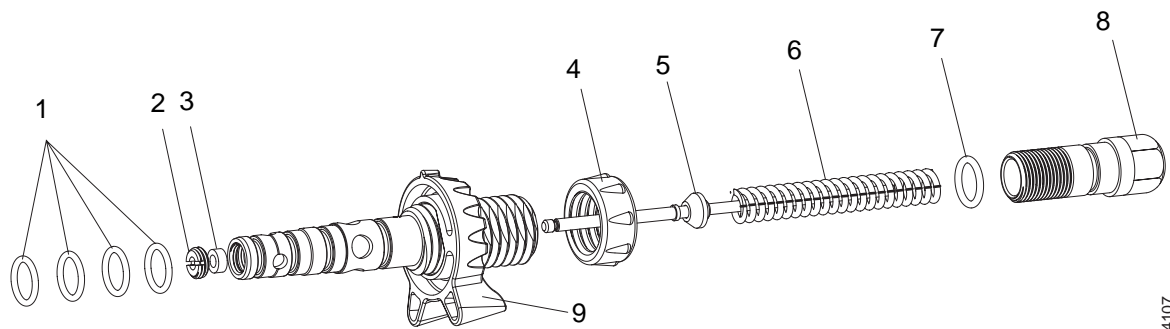

DES04107

Item	Part number	Description	Qty	Unit of sale	Spare Part Level (*)
	910004753	Air Distributor Assembly for SX 200 version	1	1	3
	910007034	Air Distributor Assembly for SX 120 version	1	1	3
1	J3STKL102	Chemically-inert O-ring	4	1	1
2	900000231	Air distributor stuffing box	1	1	3
3	J3TPRF125	Lip seal	1	1	1
4	548024	Air distributor nut	1	1	3
5	900003919	Air valve	1	1	2
6	900000193	Compression spring for SX 200 version	1	1	3
	900005199	Compression spring for SX 120 version	1	1	3
7	J3STKL121	Chemically-inert O-ring	1	1	1
8	900000228	Knurled nut for SX 200 version	1	1	3
	900005200	Knurled nut for SX 120 version	1	1	3
9	900000179	Selector	1	1	3

(*)

Level 1: Standard preventive maintenance.

Level 2: Corrective maintenance.

Level 3: Exceptional maintenance.

Part number	Description	Qty	Unit of sale	Spare Part Level (*)
910006119	Air distributor seals kit - All versions	1	1	1
J3TPRF125	Lip seal	1	1	1
J3STKL102	Chemically-inert O-ring	4	1	1
J3STKL121	Chemically-inert O-ring	1	1	1

13.9. Electropneumatic coupling sets

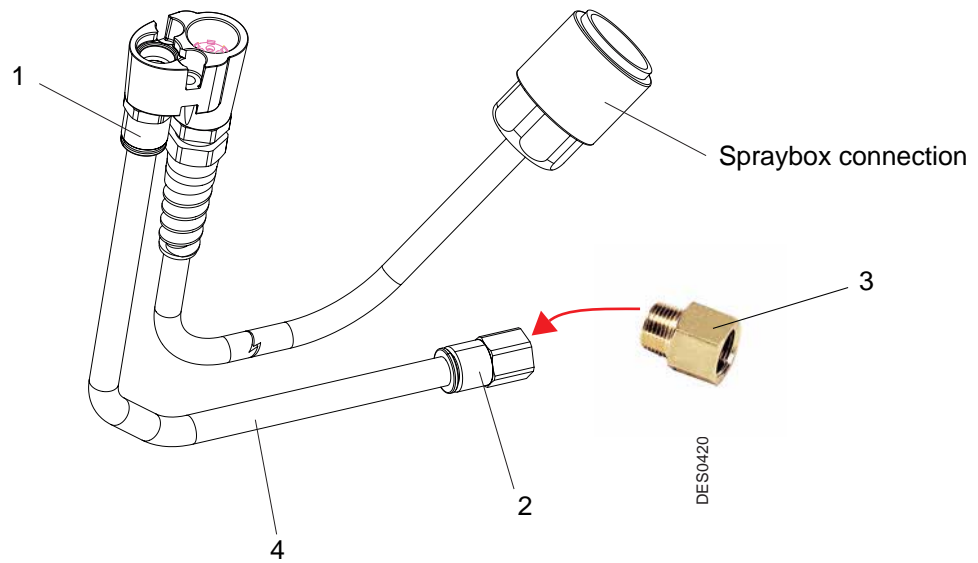

Item	Part number	Description	Qty	Unit of sale	Spare Part Level
	910003619-10	HR-LR 10m Electropneumatic coupling	1	1	
	910003619-15	HR-LR 15m Electropneumatic coupling	1	1	
	910003619-20	HR-LR 20m Electropneumatic coupling	1	1	
	910003619-30	HR-LR 30m Electropneumatic coupling (only for the HP versions)	1	1	
1	F6RLUS225	Straight union - male	1	1	3
2	130000527	Straight union - female	1	1	3
3	F6RLHG362	Female NPT / Male BSP adapter	1	1	3
4	U1GLBT133	Polyurethane hose - Ext. D: 10 blue	10 m 15 m 20 m 30 m	m	1



WARNING : The 30 m-electropneumatic coupling is only to be used for HP versions.

13.10. Paint hoses

13.10.1. For Spraymium Low Pressure and High Pressure High Resistivity spray guns

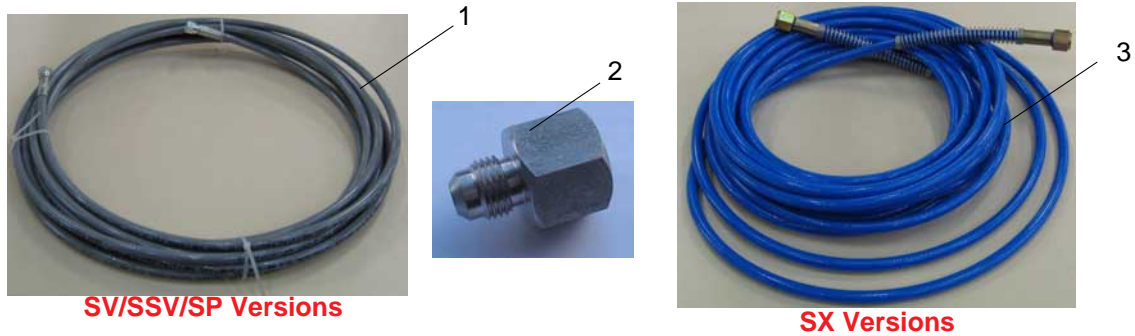

Item	Part number	Description	Qty	Unit of sale	Spare Part Level
For Spraymium SV/SSV/SP spray guns					
1	050450707	HR/LP product hose - 10m grey Dia 6.3	1	1	1
	050450709	HR/LP product hose - 15m grey Dia 6.3	1	1	1
	050450708	HR/LP product hose - 20m grey Dia 6.3	1	1	1
2	050123306	M1/2 JIC adapter - F3/8NPS	1	1	2
For Spraymium SX spray guns					
3	050450606	HR/HP product hose - 10m blue Dia 4.8	1	1	1
	050450607	HR/HP product hose - 15m blue Dia 4.8	1	1	1
	050450608	HR/HP product hose - 20m blue Dia 4.8	1	1	1
	050450609	HR/HP product hose - 30m blue Dia 4.8	1	1	1

13.10.2. For Spraymium Low Pressure and High Pressure Low Resistivity spray guns



Item	Part number	Description	Qty	Unit of sale	Spare Part Level
For Spraymium SV/SSV/SP/SX spray guns					
1	910002417	LR - HP/LP product hose - 10m black Dia 4.8	1	1	1
	910008120	LR - HP/LP product hose - 5m black Dia 4.8	1	1	1
	910006398	LR - HP/LP product hose - 15m blue Dia 4.8	1	1	1
	910006463	LR - HP/LP product hose - 20m blue Dia 4.8	1	1	1
For Spraymium SX spray guns					
	910006464	LR - HP/LP product hose - 30m blue Dia 4.8	1	1	1

13.11. Spraybox Control module



Item	Part number	Description	Qty	Unit of sale	Spare Part Level
	110000352	CE Spraybox control module	1	1	3
	110000873	FM / CSA Spraybox control module	1	1	3
	910005759	Spraybox attachment kit	1	1	3
	842635	5-m ground cable, lug dia.: 6	1	1	3
	910008791	Spraybox external trigger cable	1	1	3

13.12. Options for Spraymium Low Pressure spray guns

13.12.1. Fan Spray Air Cap

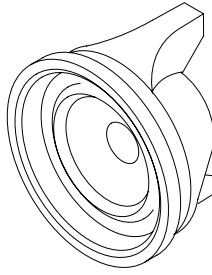

DES04202

Part number	Description	Qty	Unit of sale	Spare Part Level
737550	SPE Air Cap (narrow fan spray)	Option	1	1
737552	SPL Air Cap (broad fan spray)	Option	1	1

13.12.2. 4-finger trigger kit

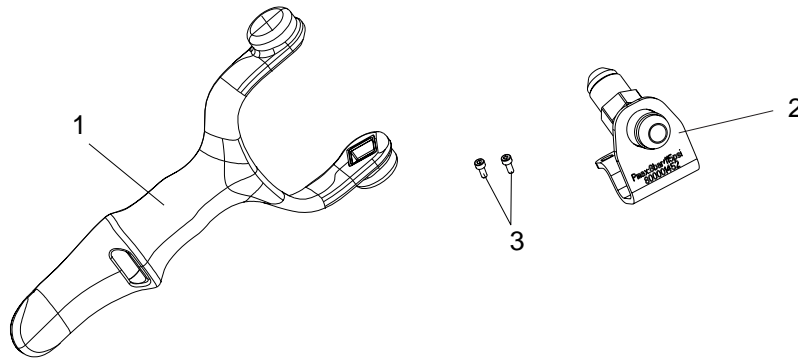

DES04205

Item	Part number	Description	Qty	Unit of sale	Spare Part Level
	910006140	4-finger trigger kit - LP - HR	Option	1	3
1	900000177	4-finger trigger	1	1	3
2	910004279	Hose holder	1	1	3
3	X4FVSY118	Stainless steel 316 Allen screws, M 4 x 10	2	1	3

13.12.3. In-line product filters

These small filters are fitted in the spray gun handle (with HR models).

Description	Part number	Versions
Filter (Male-Female 1/2 JIC)	155010100	LP HR
Screen nr 12	129609909	



WARNING : The filter is delivered with a 6mm screen as standard. Before installation of LP models, you are advised to replace the screen nr 6 from the initial design with a screen nr 12.

With LR models, it is necessary to remove the fitting F 3/8 NPT- M1/2 JIC located at the pump outlet and to replace it by the filter.

Description	Part number	Versions
Filter (pump outlet) F 3/8 NPT- M1/2 JIC	155580300	HP LR
Screen nr 6	000161106	

13.13. Options for Spraymium High Pressure spray guns

13.13.1. X14 Tips for SX version

Part number	Description	Qty	Unit of sale	Spare Part Level
134506079	X14 06-079 Tip	Option	1	1
134506099	X14 06-099 Tip	Option	1	1
134506119	X14 06-119 Tip	Option	1	1
134506139	X14 06-139 Tip	Option	1	1
134509079	X14 09-079 Tip	Option	1	1
134509099	X14 09-099 Tip	Option	1	1
134509119	X14 09-119 Tip	Option	1	1
134512099	X14 12-099 Tip	Option	1	1
134512119	X14 12-119 Tip	Option	1	1
134512139	X14 12-139 Tip	Option	1	1
134514099	X14 14-099 Tip	Option	1	1
134514179	X14 14-179 Tip	Option	1	1

13.13.2. 4-finger trigger kit

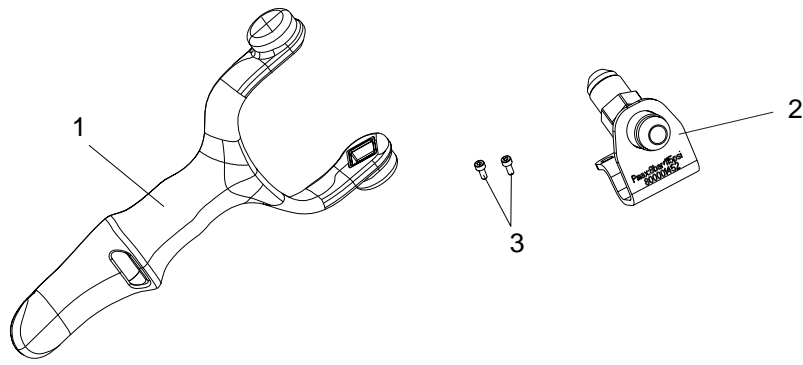

DES04205

Item	Part number	Description	Qty	Unit of sale	Spare Part Level
	910005973	4-finger trigger kit - HP - HR	Option	1	3
1	900000177	4-finger trigger	1	1	3
2	910005987	Hose holder	1	1	3
3	X4FVSY118	Stainless steel 316 Allen screws, M 4 x 10	2	1	3
	910007093	4-finger trigger kit - HP (SX 120) - HR	Option	1	3
1	900000177	4-finger trigger	1	1	3
2	910007091	Hose holder	1	1	3
3	X4FVSY118	Stainless steel 316 Allen screws, M 4 x 10	2	1	3

13.13.3. Swivel fitting for paint hose

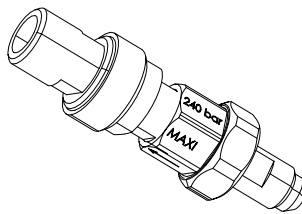

DES04203

Part number	Description	Qty	Unit of sale	Spare Part Level
129670405	Swivel fitting	Option	1	2

13.13.4. In-line product filters

These small filters are fitted in the spray gun handle (with HR models).

Description	Part number	Versions
Filter (Male-Female 1/2 JIC)	155010100	HP HR
Screen nr 6	129609908	

With LR models, it is necessary to remove the fitting F 3/8 NPT- M1/2 JIC located at the pump outlet and to replace it by the filter.

Description	Part number	Versions
Filter (pump outlet) F 3/8 NPT- M1/2 JIC	155580300	HP LR
Screen nr 6	000161106	

13.14. Appendices

13.14.1. Protective hose covering

This covering can be used to protect hoses and cables to ensure long life and flexibility.

Description	Part number	Unit of sale
 Protective hose covering (10 m)	100000066	10 m roll

13.14.2. Protective case for spray gun

Description	Part number	Unit of sale
 Protective case DES01269	100000081	10

13.14.3. Warning notice and maintenance instructions notice

Description	Part number	Unit of sale
 Warning notice DES00790	1407684	1
Maintenance instructions notice	900004605	1

13.14.4. Safety valve

Description	Part number	Unit of sale
 Safety valve 6.5 bar 1/4 G	903080401	1