



From February 1st, 2017 SAMES Technologies SAS becomes SAMES KREMLIN SAS
A partir du 1/02/17, SAMES Technologies SAS devient SAMES KREMLIN SAS

SAMES  **KREMLIN**



User manual

Robot Control Module REV 800 Installation Manual

SAS SAMES Technologies. 13 Chemin de Malacher -
Inovallée - CS 70086 - 38243 Meylan Cedex France
Tel. 33 (0)4 76 41 60 60 - Fax. 33 (0)4 76 41 60 90 - www.sames.com

All communication or reproduction of this document, in any form whatsoever and all use or communication of its contents are forbidden without express written authorisation from SAMES Technologies.

The descriptions and characteristics mentioned in this document are subject to change without prior notice.

© **SAMES Technologies 2015**



WARNING : SAS Sames Technologies is registered with the Ministry of Labour as a training institution.

Throughout the year, our company offers training courses in the operation and maintenance of your equipment.

A catalogue is available on request. Choose from a wide range of courses to acquire the skills or knowledge that is required to match your production requirements and objectives.

Our training courses can be delivered at your site or in the training centre at our Meylan head office.

Training department:

Tel. 33 (0)4 76 41 60 04

E-mail: formation-client@sames.com

SAS Sames Technologies operating manuals are written in French and translated into English, German, Spanish, Italian and Portuguese.

The French version is deemed the official text and Sames will not be liable for the translations into other languages.

Robot Control Module
REV 800
Installation Manual

1. Health and Safety Instructions - - - - -	4
2. Description - - - - -	5
3. Installation - - - - -	7
3.1. <i>Description</i>	7
3.2. <i>Operating Conditions</i>	10
3.3. <i>Cleaning and Maintenance of the Touch Panel</i>	10
3.4. <i>Mechanical Characteristics</i>	11
3.4.1. <i>General Characteristics of the Module.</i>	11
3.4.2. <i>Dimensions of the Module</i>	11
3.5. <i>Electrical Characteristics</i>	12
3.5.1. <i>Characteristics of the Module</i>	12
3.5.2. <i>Connectors.</i>	12
3.5.3. <i>Inputs</i>	13
3.5.4. <i>Outputs</i>	14
3.5.5. <i>24VDC Power Supply</i>	16
3.6. <i>General Installation Diagram</i>	17
3.6.1. <i>Robot</i>	17
3.6.2. <i>Interface installation.</i>	18
4. Connections - - - - -	19
4.1. <i>Ground Connection</i>	19
4.2. <i>Connecting the Mains Supply to the Module</i>	19
4.2.1. <i>Electrical Wiring Diagrams.</i>	19
4.2.2. <i>Control Module.</i>	19
4.3. <i>Connections to the RFV 2000 Robots</i>	20
4.3.1. <i>Electrical Wiring Diagrams.</i>	20
4.3.2. <i>Control Module.</i>	21
4.4. <i>Connections to the Spray Triggers</i>	24
4.4.1. <i>Electrical Wiring Diagrams.</i>	24
4.4.2. <i>Control Module.</i>	26
4.5. <i>Interface to the Plant Control System</i>	27
4.5.1. <i>Electrical Wiring Diagrams.</i>	27
4.5.2. <i>Control Module.</i>	28
5. Spare parts- - - - -	33

1. Health and Safety Instructions

This user manual contains a link un lien to the following user manual:

- [see RT Nr 6364](#) for the electrical systems.



WARNING : This equipment may be hazardous when not used following the safety rules described in this manual:

- The REV 800 module is intended to be installed in a control cabinet made by Sames Technologies which provides the basic level of sealing of the product from its environment (water splashes, pollution from powder and from dust...). Any utilisation other than prescribed by Sames remains the sole responsibility of the end user (like when used outside of a control cabinet, or installed in an electrical cabinet not made by Sames Technologies).
- The REV 800 module must be installed outside of ATEX zones.
- The REV 800 module must be installed away from the powder polluted area.
- The REV 800 module cannot be installed out of doors.
- Ambient temperature in the vicinity of the REV 800 modules must be lower or equal to 40 C degrees.
- The REV 800 module must be connected to the shop's earth via a green/yellow wire of an at least 6mm² section.
- The REV 800 module must not be used without its cover.
- The REV 800 module must not be modified from its original design.
- Only Sames Technologies spare parts, or a repair carried out by the repair department of Sames will ensure and ascertain the safe operation of the REV 800 module.
- Switch off the electrical power to the REV 800 module prior to pulling off its connectors.
- **The "booth ventilation ON" information must be connected to the REV 800 module in order to allow spraying only while the booth ventilation is turned on. Should this connection not be established, the operation of the system falls entirely under the responsibility of the end user.**
- The touch-screen of the REV 800 module is designed for use with clean or protected hands. There is a protective film to be installed on the screen area. The warranty does not cover pollution of the touch-screen of the REV 800 module by powder paint.
- **The REV 800 module is exclusively designed to operate with one or two Sames Technologies RFV reciprocators, which must be installed in an ATEX zone. Any other utilisation of the reciprocator falls under the sole responsibility of the end user.**
- **The REV 800 module is designed to be used only in conjunction with the potentiometers installed by Sames on the RFV series reciprocators. This whole electrical system is certified by Sames, and guarantees that the potentiometer can be used in an ATEX zones. The zener barrier of this system must be installed at the rear of the control module REV 800 on a rail provided for this purpose and connected.**
- **The thermal probe of the RFV's motor must be connected to the REV 800 module in order to guarantee the utilisation of the RFV in an ATEX zone.**
- Any intervention on the REV 800 module under voltage has to be made only by personal authorized and formed to the electrical interventions .

2. Description

The **REV 800** control module is capable of controlling up to two Sames **RFV 2000** robots. It is used to control the up and down vertical oscillation that has been programmed for each of the robots to suit the characteristics of the part being processed.

The motion of each robot may be different.

In the case of using the module without part detection or with a simple detection, this motion is divided into three distinct zones. Each of these zones may be programmed to a different oscillation speed with the spray enabled or disabled.

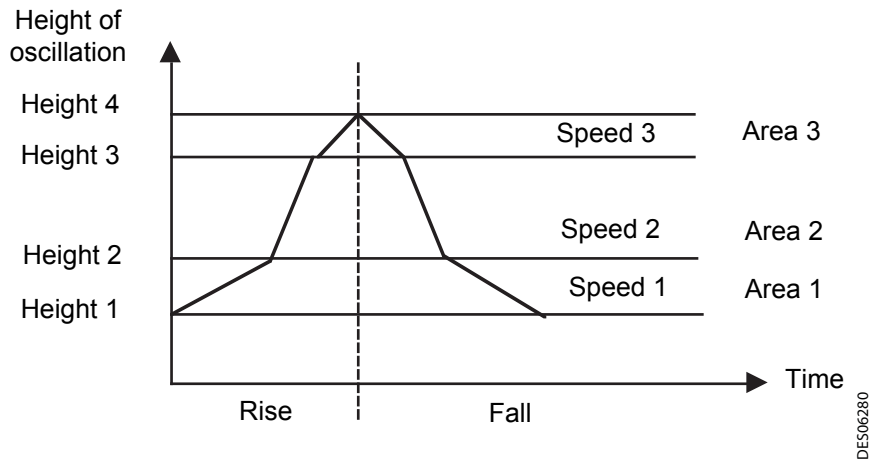

In the case of using the module with a part detection by cells barrier, a scanning area can be divided into 6 spray areas. A spray authorization is associated with each area.

The module also controls the triggering of up to twelve Sames spray guns or sprayers via a Sames spray module. These may be used with either liquid paint or powder.

The module is easy to interface to a plant control system using the following functions:

- Automatic spraying when parts are detected by a sensor or photocell or a cells barrier.
- Input provided for an emergency stop switch if required.
- External fault input.
- Ventilation running input
- Conveyor running input.
- Conveyor encoder pulse input.
- Conveyor control output.
- OK module output.

The REV 800 is a 19 inch rack-mountable unit intended to be housed in a Sames FCR or SLR modular cabinet together with various Sames 19 inch spray modules.

It may also be used as a stand-alone unit, housed in a Sames installation cabinet.



WARNING : The REV 800 module must be imperatively installed outside of ATEX zones and in an atmosphere not polluted by residues of powder or liquid paints.

Block diagram of the system

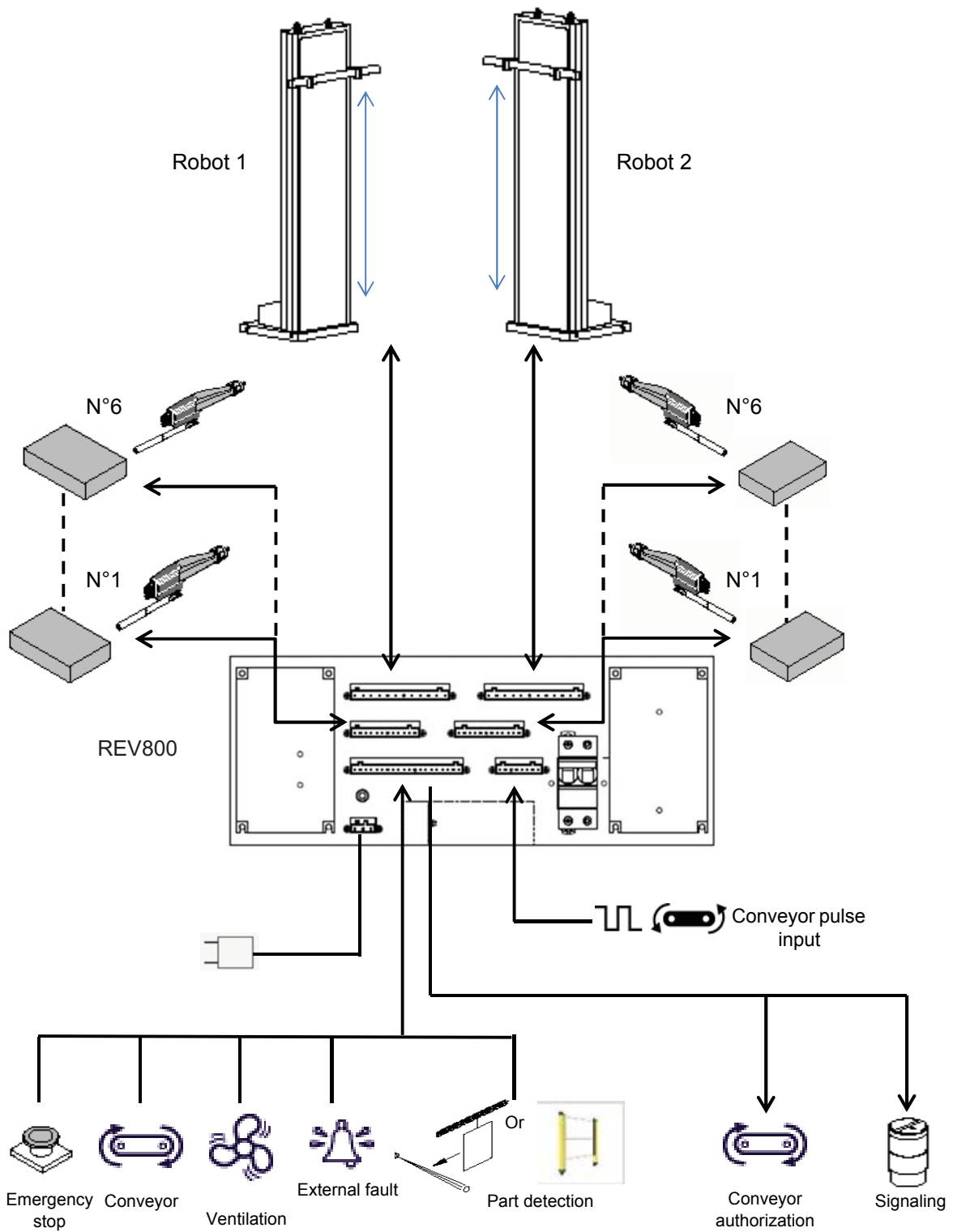

Note: [see § 4 page 19](#) for the details of the connections.

3. Installation

3.1. Description

The architecture of the REV 800 module is based on a programmable logic controller, a touch-sensitive operator control panel and two speed converters.

Layout (from above)

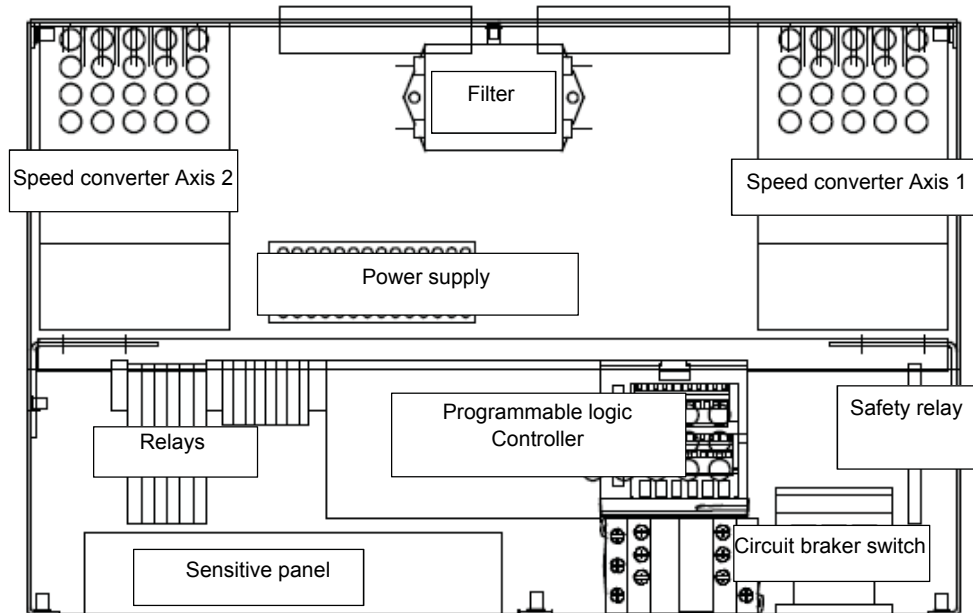

DE506282

The Programmable Logic Controller (PLC) consists of the following 2 modules:

- CPU module with integrated digital logic and analogic signal inputs and outputs.
- Additional relays output module

The digital logic signal inputs and outputs are used primarily for:

- Interfacing with the plant control system.
- Controlling the triggering of the spray guns or sprayers.
- Transmitting data specific to the module.

The analog inputs are used to acquire positional data from the rotational potentiometers on each axis. The analog outputs are used to transmit a speed demand signal to the speed converters.

The speed converters are used to:

- Supply a reference voltage to the rotational potentiometers.
- Drive the induction motor actuators on the RFV 2000 robots.

The graphical Touch Panel operates together with the Programmable Logic Controller to provide the Man-Machine Interface for the module.

A **24 VDC power supply unit** supplies power to the various PLC modules.

The relay block is used to:

- Interface the triggering signals to the spray guns or sprayers.
- Exchange data specific to the module.

The circuit breaker switch is used to isolate the robots during maintenance operations by cutting the power supply to the RFV 2000 robots.

A protective **circuit breaker** (accessible in the rear face) is included in the power supply in order to protect the module.

Front panel

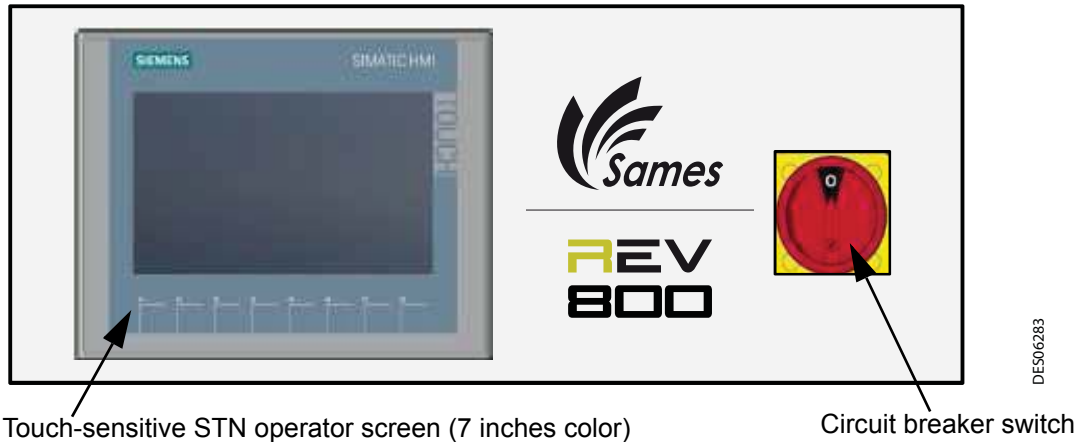

All interfacing between the operator and the module is provided by the graphical Touch Panel connected to the Programmable Logic Controller:

- 7 inches LCD TNT widescreen, backlit by CCFL. The screen is easy to read even under difficult lighting conditions.
- Resistive analog touch-sensitive screen, controlled by a finger, non-pointed object or glove.
- Strong plastic case, protected to IP65 (front panel) and IP20 (rear panel).

The lockable circuit breaker switch is used to isolate the robots during maintenance operations by cutting the power supply to the speed converters. The switch may be locked using a padlock.

A reset by a validation button at the operator screen is required to restore power to the converters.



WARNING : Even when the switch is in position 0, power continues to be supplied to the operator control panel. However, it is not possible to drive the movement of the robots or trigger the sprayers electrically (stop mode).

When the switch is activated to 1 and the power is reset on the HMI device, installation passes in manual or automatic mode.

Before putting the switch on position 1 and validating the power on the HMI, the operator must ensure that nobody is in the working area of the installation.

The non respect of this instruction is under the responsibility of the user.



WARNING : If not used for five minutes, the screen enters screen-saver or stand-by mode and appears to be switched off. Touching the screen will bring it out of stand-by mode immediately.

Rear view

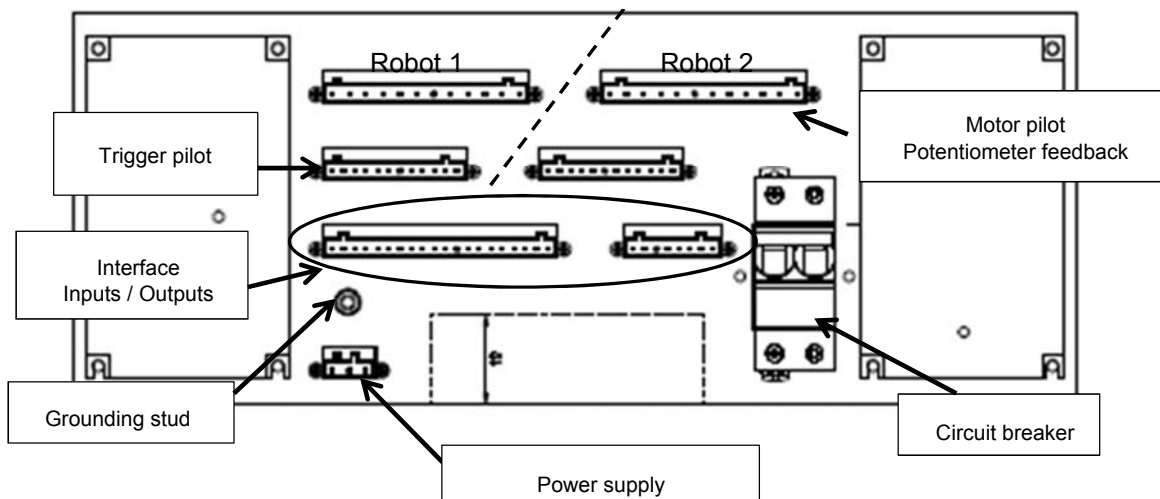

DES06284

Connections are made to the system via connectors with spring-loaded terminals. Ferrules should not be used on the connecting wires as this method provides a tight vibration-resistant connection.

The connectors are locked in position by means of catches. These are easy to use and no tools are required. Each individual connector can only be inserted in one orientation.

Each female connector is fitted with a handle and cable clamp preventing any tension on the individual wires as the connector is withdrawn.

The power and speed converter connectors have a pitch of 7.5 mm. The control signal connectors have a pitch of 5.08 mm.

Signalitic plate of the equipment

CE	
SAMES	
TYPE:	REV 800
SAMES REF.: 910019970	
Input voltage: 230V (Mono) +/- 10%	
Input frequency: 47-63 Hz	
Input current: 16 A	
Serial N°	<input style="width: 100%;" type="text"/>
Date	<input style="width: 100%;" type="text"/>
Software	<input style="width: 100%;" type="text"/>

3.2. Operating Conditions

Ambient temperature	< 40°C
Relative humidity	< 85% non-condensing
Altitude	< 1000m (Speed converters must be derated above this level)
Environment	Non-explosive

3.3. Cleaning and Maintenance of the Touch Panel

The control panel screen is designed to operate with the minimum of maintenance. Regular maintenance is limited to cleaning the screen.

Cleaning the screen

Preparation

The control panel screen should be cleaned periodically. Clean the screen using a damp cloth and clean from the screen edge inwards. Switch off the equipment before cleaning the screen. This will eliminate any chance of selecting unwanted operations.

Clean display

If the equipment includes a 'Clean display' function, you may clean the screen while the timer bar is active without the risk of selecting any other functions. All input from the screen is disabled during this period.

Protective film

An optional protective film is available for the screen (P/N # 110002029). This film prevents scratching or damage to the screen.

Cleaning products

Dampen the cloth with water and a mild detergent (washing-up liquid) or a foam product specially designed for cleaning screens. Spray the cleaner onto the cloth, never directly onto the screen. Do not use aggressive solvents or abrasive cleaners.



WARNING : Touch Panel should not be put in contact with liquid products or powders otherwise there is a risk of damaging it.

3.4. Mechanical Characteristics

3.4.1. General Characteristics of the Module

Rack mounted	19 inch
Height	4 U
Protection index	IP20 (case), IP 54 (front panel)
Weight	13.8 kg

3.4.2. Dimensions of the Module

Front panel

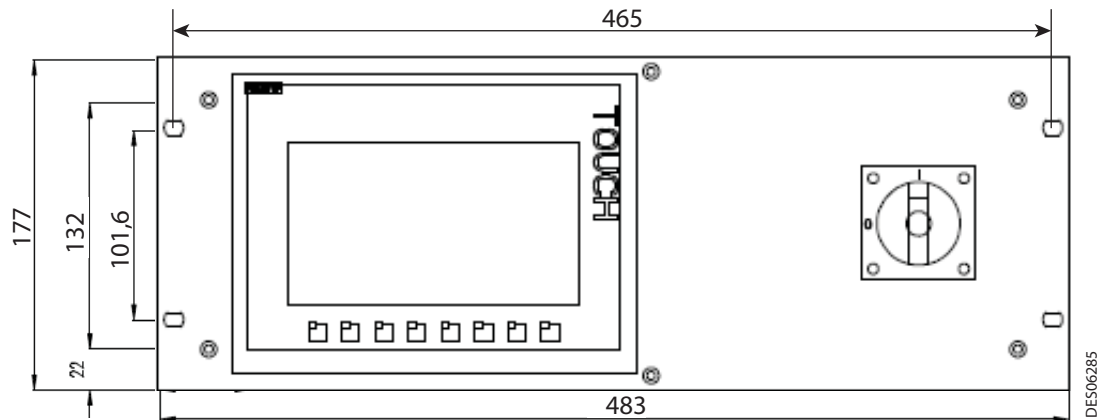

Rear panel

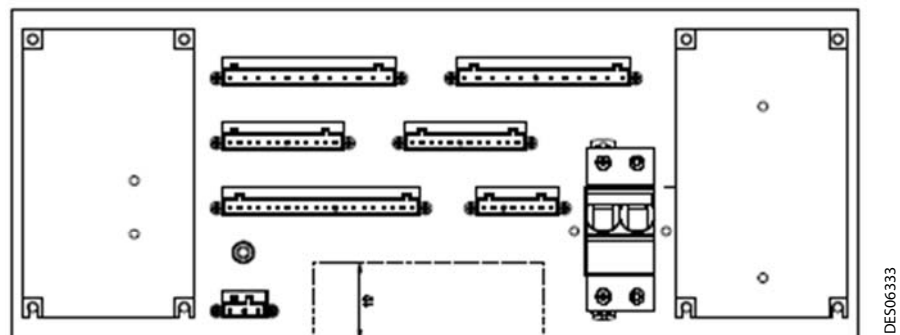

View from above

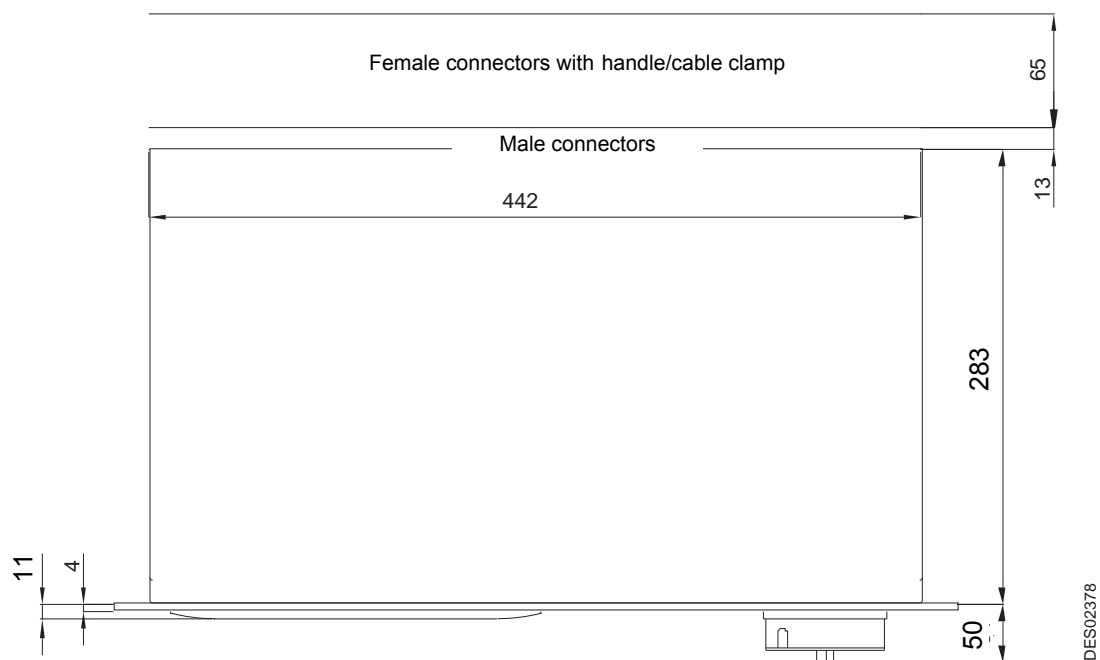

3.5. Electrical Characteristics

3.5.1. Characteristics of the Module

Input voltage	230 single phase ($\pm 10\%$)
Frequency range	47-63 Hz
Input current (max.)	16 A

3.5.2. Connectors

Connectors with a pitch of 7.5 mm	
Maximum voltage	300 V
Maximum current	15 A
Nominal conductor size	0.08 to 2.5 mm ²

Connectors with a pitch of 5.08 mm	
Maximum voltage	300 V
Maximum current	10 A
Nominal conductor size	0.08 to 2.5 mm ²

3.5.3. Inputs

3.5.3.1. Integrated Digital Logic Signal Inputs

General	24 V Inputs
Type	P/N (CEI type 1 in P mode)
Nominal voltage	24 VDC at 4 mA (typ.)
Maximum permissible continuous voltage	30 VDC
Transient voltage	35 VDC for 0.5 seconds
Logical '1' (min.)	15 V at 2.5 mA
Logical '0' (max.)	5 VDC at 1 mA
Input delay	Selectable (0.2 to 20 ms)
Current consumption	4 mA / used input
Isolation(side field to logic)	500 VAC for 1 minute
Isolation group	1
HSC input frequency (max.) Logic 1 = 15-26 V for conveyor encoder input	20Khz
Maximum number of inputs simultaneously at '1'	All at 55°C in horizontal, at 45°C in vertical
Cable length (max.) Shielded Unshielded	500 m (normal inputs), 50 m (HSC inputs) 300 m (normal inputs)

3.5.3.2. Integrated Analog Inputs

General	
Type	Voltage (single-ended)
Full scale range	0 to 10 V
Data word format (full scale)	0 to 27648
Overshoot range	10.001 to 11.759 V
Data word overshoot range	27649 to 32511
Overflow range	11.760 to 11.852 V
Data word overflow range	32512 to 32767
Resolution	10 bits
Maximum withstand voltage	35 V
Smoothing	None, Weak, Medium, or Strong
Noise rejection	10, 50 or 60 Hz
Impedance	≥ 100 kΩ
Isolation (side field to logic)	None
Accuracy (25 °C / 0 to 55 °C)	3.0% / 3.5% of full scale
Cable lenght (meters)	100 m, shielded twisted pair

3.5.4. Outputs

3.5.4.1. Relay Outputs

8 additional relays module (piloting of triggers 3 to 6 for each robot)

General	
Type	8 Relays, change over contact relay
Voltage range	5 to 30 VDC or 5 to 250 VAC
Current (max)	2A
Surge current (max.)	7 A with contacts closed
Lamp load (max.)	30 W DC / 200 W AC
On state contact resistance	0,2 Ω max. when new
Overload protection	no
Isolation (field side to logic)	1500 VAC for 1 minute (coil to contact)
Isolation resistance	100 M Ω min. when new
Isolation between open contacts	750 VAC for 1 minute
Isolation group	8
Switching delay (max)	10 ms
Switching frequency (max)	1 Hz
Lifetime mechanical (without load)	10 000 000 open/close cycles
Lifetime contact at rated load	100 000 open/close cycles
Maximum number of outputs simultaneously at '1'	All at 55°C in horizontal, at 45°C in vertical
Cable length (max.)	
Shielded	500 m
Unshielded	150 m

Block relay (piloting of triggers 1 to 2 of each robot and of exchange data specific to the module)

Floating contact

Maximum switched voltage	250/250 VAC
Maximum current	6 A
Maximum switched power	1500 VA AC
Nominal load (230 VAC)	400 VA
Minimum switched load	10 VDC / 10 mA, 24 VDC / 1 mA
Contact material	AgNi

Mechanical life	5 000 000 cycles
Response time (pull-in / release)	8 / 4 ms
Dielectric strength (contacts open)	1000 VAC

3.5.4.2. Integrated transistor Logic Signal Outputs

General	24V Outputs
Type	Solid state - MOSFET (sourcing)
Voltage range	20.4 to 28.8 V
Surge current (max.)	8 A for 100 ms
Logic 1 signal (min.)	20 VDC at maximum current
Logic 0 signal (min.)	0.1 V with a 10 kΩ load
Current (max.)	0.5 A
Leakage current per point (max.)	10 μA
Lamp load (max.)	5 W
On state resistance (contact)	0.6 Ω max
Overload protection	no
Isolation (field side to logic)	500 VAC for 1 minute
Isolation group	1
Switching delay (max) Off to on / On to off	1/3 μs (Qa.0 to Qa.3) 50/200 μs (for the other)
Maximum number of outputs simultaneously at '1'	All to 55°C in horizontal, at 45°C in vertical
Cable length (max.) Screened Unscreened	500 m 150 m

3.5.4.3. Integrated analog Outputs

General	
Type	Current
Full scale range	0 to 20 mA
Full scale range (data word)	0 to 27648
Overshoot range	20.01 to 23.52 mA
Data word overshoot range	27649 to 32511
Overflow range	
Data word overflow range	32512 to 32767
Resolution	10 bits
Output drive impedance	≤ 500 Ω max.
Isolation (field side to logic)	None
Accuracy (25 °C / 0 to 55 °C)	3.0% / 3.5% of full scale
Settling time	2 ms
Cable length (meters)	100 m, shielded twisted pair

3.5.5. 24VDC Power Supply

Switched mode power supply, protected against short circuit, overload and overvoltage.

Output voltage	24 VDC
Tolerance	± 1 %
Maximum current	3.2 A
Power	76.8 W
Efficiency	88.5 %

3.6. General Installation Diagram

3.6.1. Robot

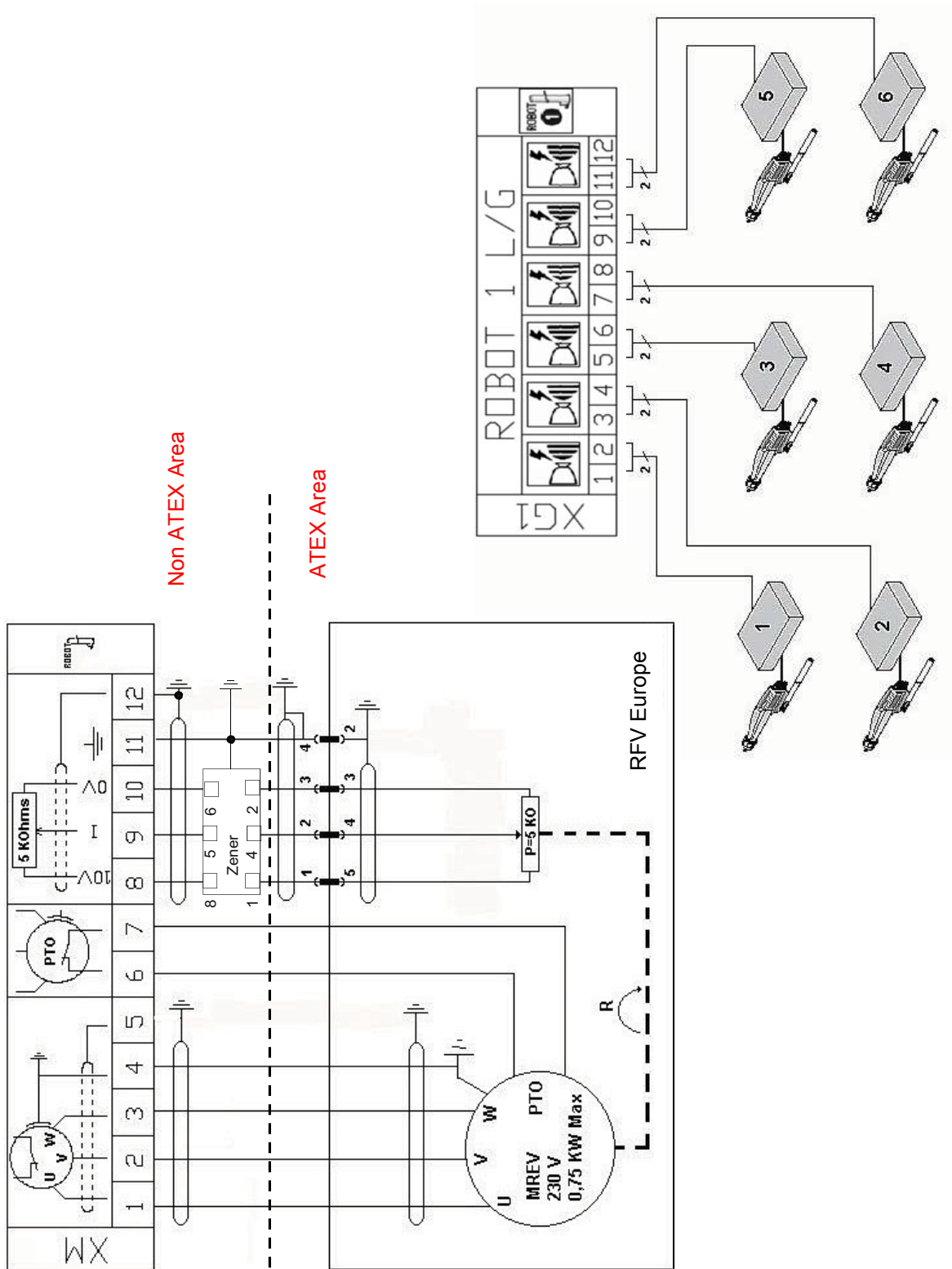

3.6.2. Interface installation

Example of installation with a detection of part by cell and an input coder for the conveyor

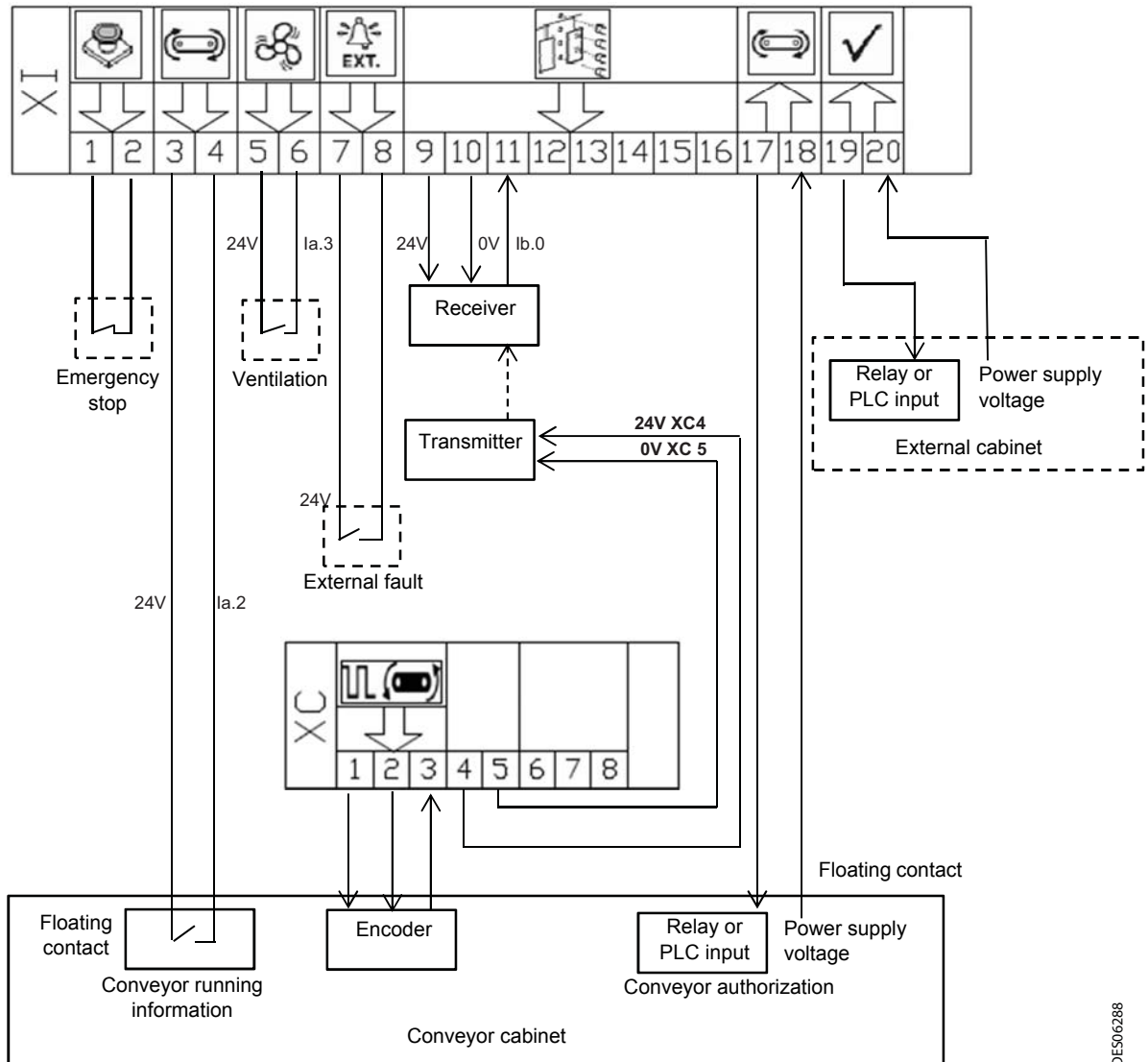

DES06288

4. Connections

4.1. Ground Connection



**WARNING : This equipment must be connected to a suitable earth!
Failure to earth this equipment correctly may give rise to dangerous conditions.**

A green/yellow earth wire of sufficient size must be connected to the grounding stud fitted and labeled as such on the rear panel of the module. The minimum recommended cable size is 2.5 mm².

4.2. Connecting the Mains Supply to the Module

4.2.1. Electrical Wiring Diagrams

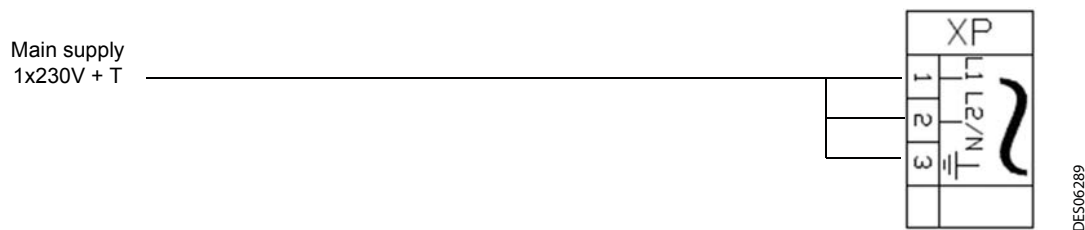

The mains voltage must be 230 Volts single-phase $\pm 10\%$.
The supply frequency must be between 47 and 63 Hertz.
The supply must be rated at a minimum of 16 Amps.

The supply cable recommended by Sames (P/N # E4PCAL580),(length 2,5 m) is equipped with a french standard plug.

4.2.2. Control Module

XP terminal strip	Power
Pin 1	L1
Pin 2	L2/N
Pin 3	Earth (green/yellow)



4.3. Connections to the RFV 2000 Robots

4.3.1. Electrical Wiring Diagrams

Motor with Integrated Thermal Sensor

The data signal from the sensor is connected in series with an integrated safety relay to cut the power on the speed convertors.

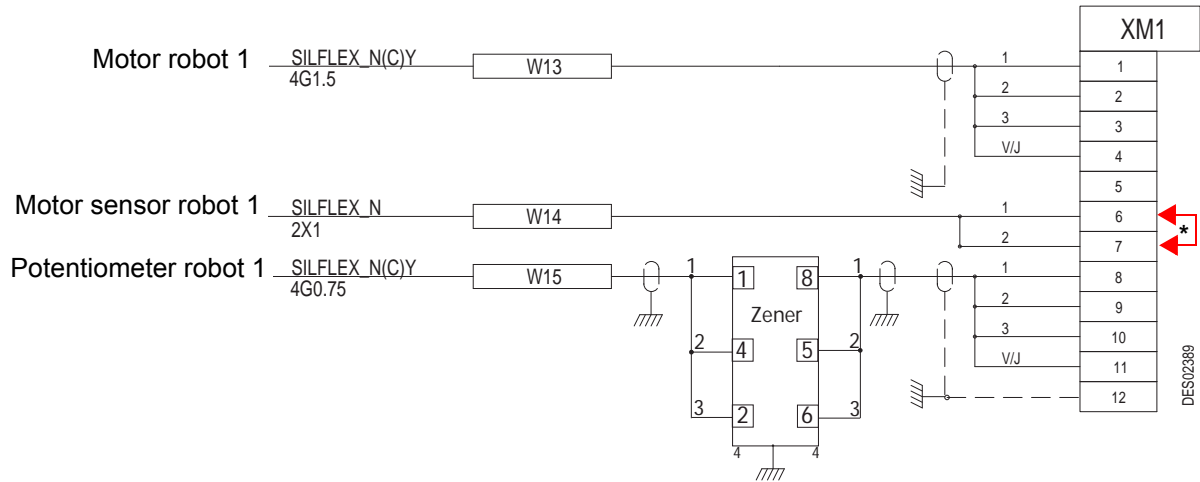

WARNING : (*) A bridge between terminals 6 and 7 is always installed on the thermal probe of the second robot. It is necessary to remove it when a second motor is connected.

The following cables are recommended:

Motor	4 G 1.5 mm ² screened	Ref: 1411222
Thermal probe	2 x 1 mm ²	Ref: 1411223
Potentiometer	4 G 0.75 mm ² screened	Ref: 1409971

Location of cables in the shielding resumption collars on the back of the REV 800:

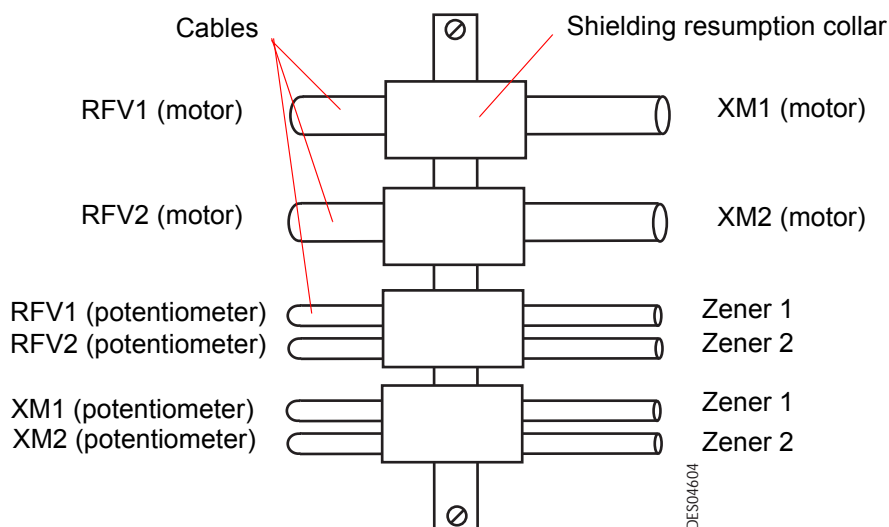

4.3.2. Control Module

4.3.2.1. Robot RFV 2000 Europe

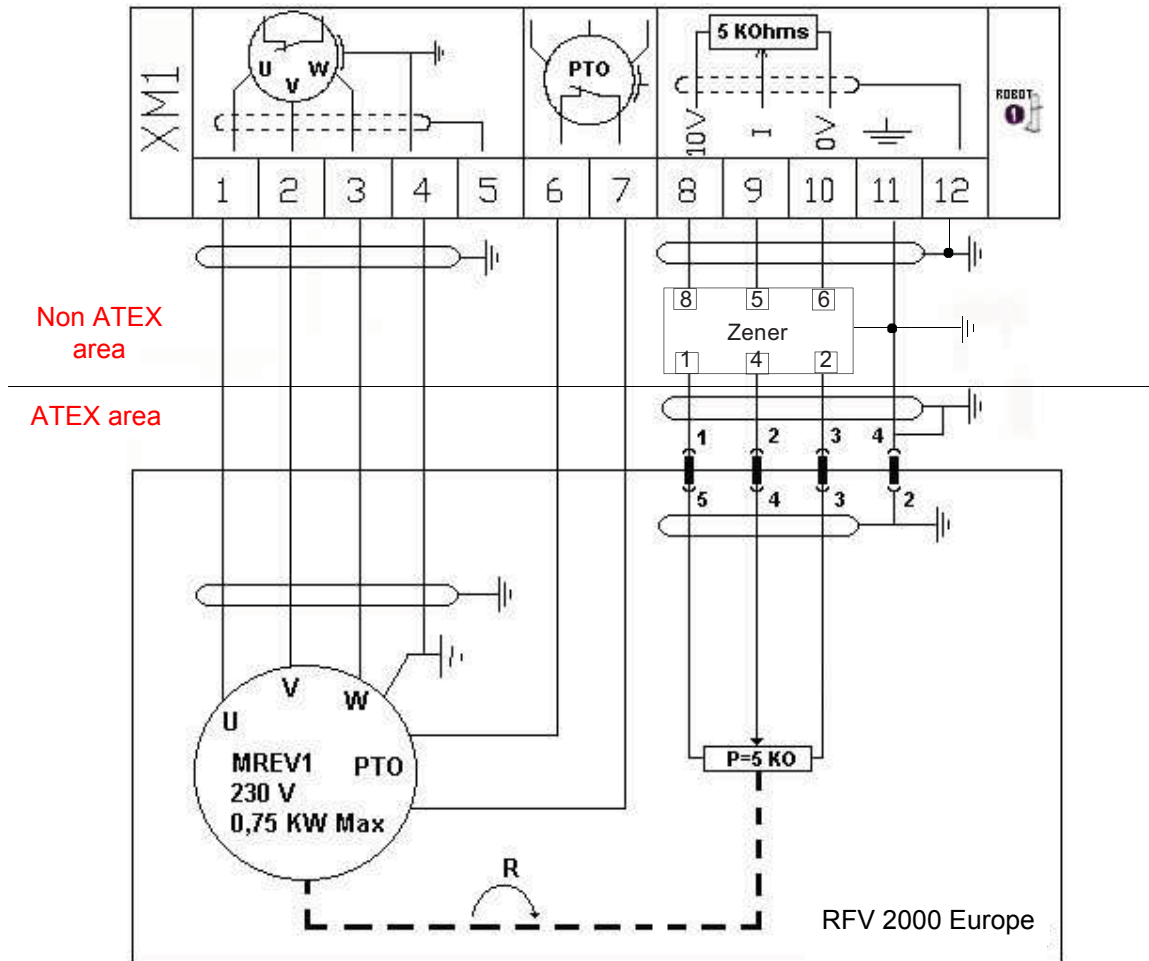

DES06291

XM terminal strip	Axis of movement
Pin 1	Motor phase U
Pin 2	Motor phase V
Pin 3	Motor phase W
Pin 4	Ground
Pin 5	Motor cable screen
Pin 6	Thermal probe
Pin 7	Thermal probe
Pin 8	10 Volt power supply to potentiometer
Pin 9	Potentiometer signal 0-10 Volts
Pin 10	Potentiometer return 0 Volts
Pin 11	Ground
Pin 12	Potentiometer cable screen

The speed converters are factory configured for a 0.75 kW / 230 Volt motor.
The motor must therefore be 'delta' connected as follows:

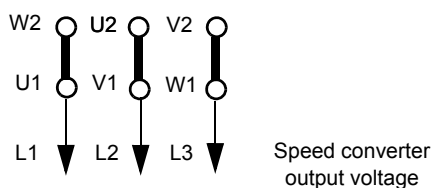

The following motor characteristics are programmed into the speed converter:

Rated motor voltage	230 V
Nominal motor current	3.60 A
Rated motor power	0.75 kW
Rated motor Cos Phi	0.72
Rated motor frequency	50 Hz
Nominal motor speed	1400 rpm
Rise time	0.3 sec
Fall time	0.3 sec
Switching frequency	4 kHz



WARNING : the potentiometer must be connected via a Zener barrier protection device which is a certified (POT31) electric system.

The Zener barrier is installed at the rear of the control module REV 800 on a rail provided for this purpose.

Part number of the cable connecting the Zener barrier to the REV 800: 1411224.

Part number of the cable of the potentiometer: 1409971.

Part number of the Zener barrier : E6GPSR077AT.

4.3.2.2. Robot RFV 2000 US

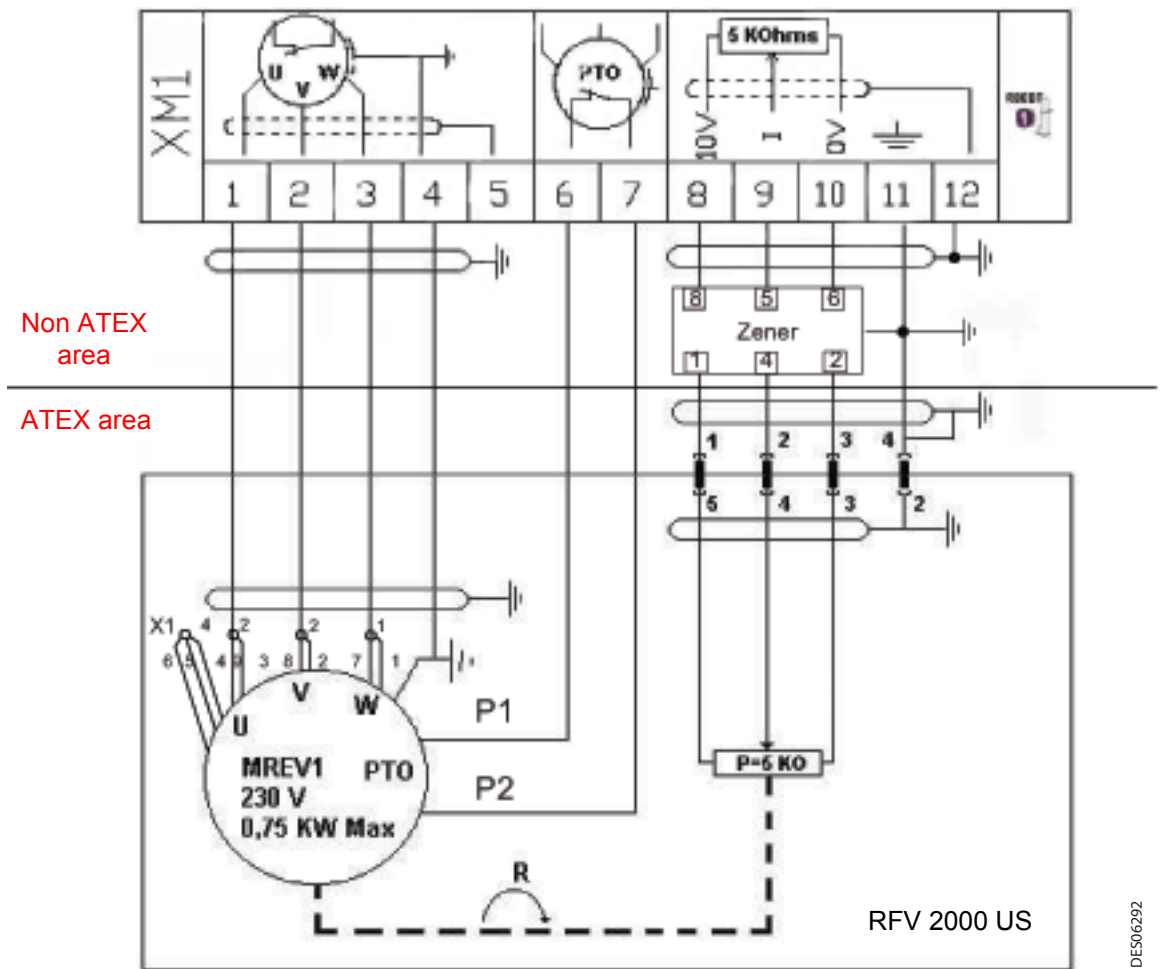

DES06292

4.4. Connections to the Spray Triggers

4.4.1. Electrical Wiring Diagrams

Each robot is capable of controlling up to six **independent** spray triggers. The term 'spray trigger' refers to a signal used to control a spray module.

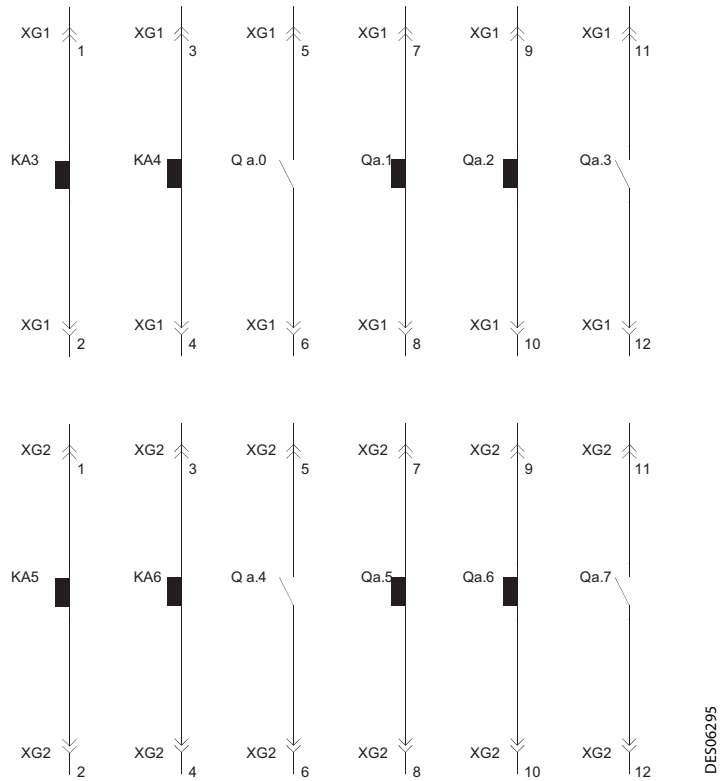

Example of connection of the CRN 457 control module.

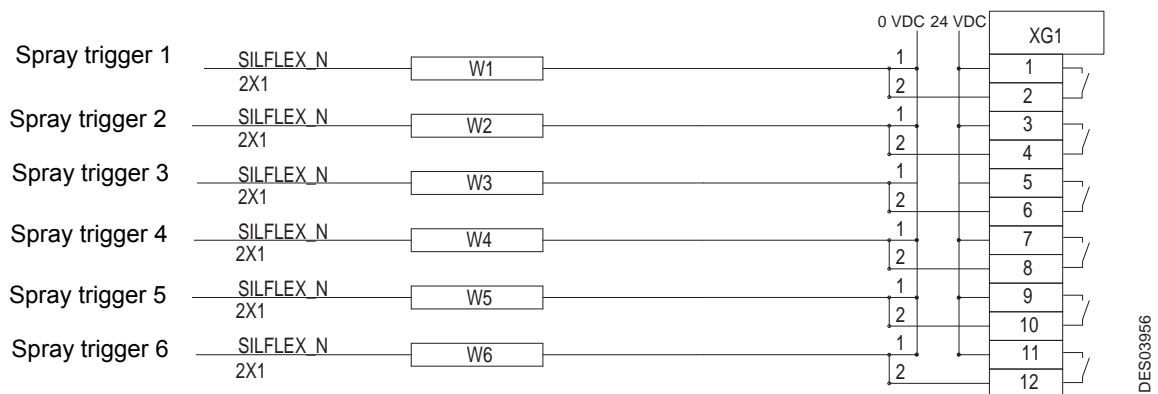

Example of connection of the TCR control module:

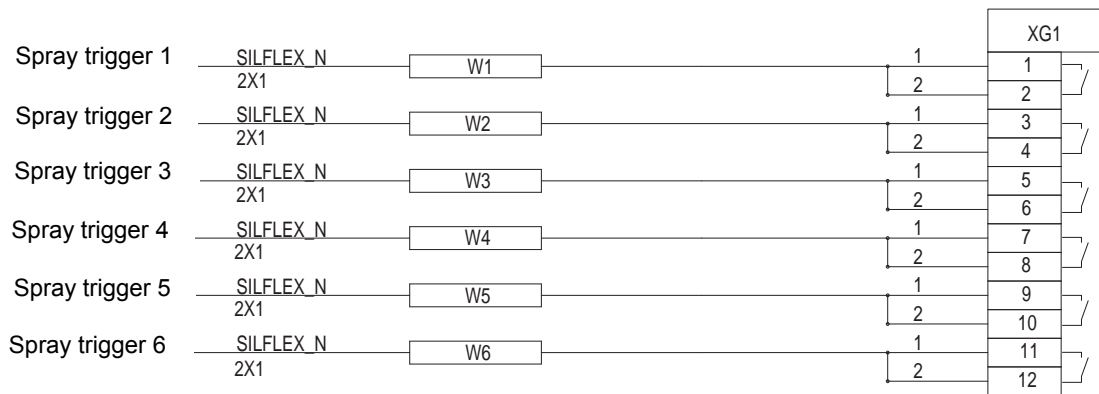

DES02393

Sames recommends a cable size of 2 x 1 mm² (P/N # E2LAAB100).

The module uses a normally open floating contact to control the spray module.

The triggers are controlled **individually**, according to the plans specified on the operator interface.

4.4.2. Control Module

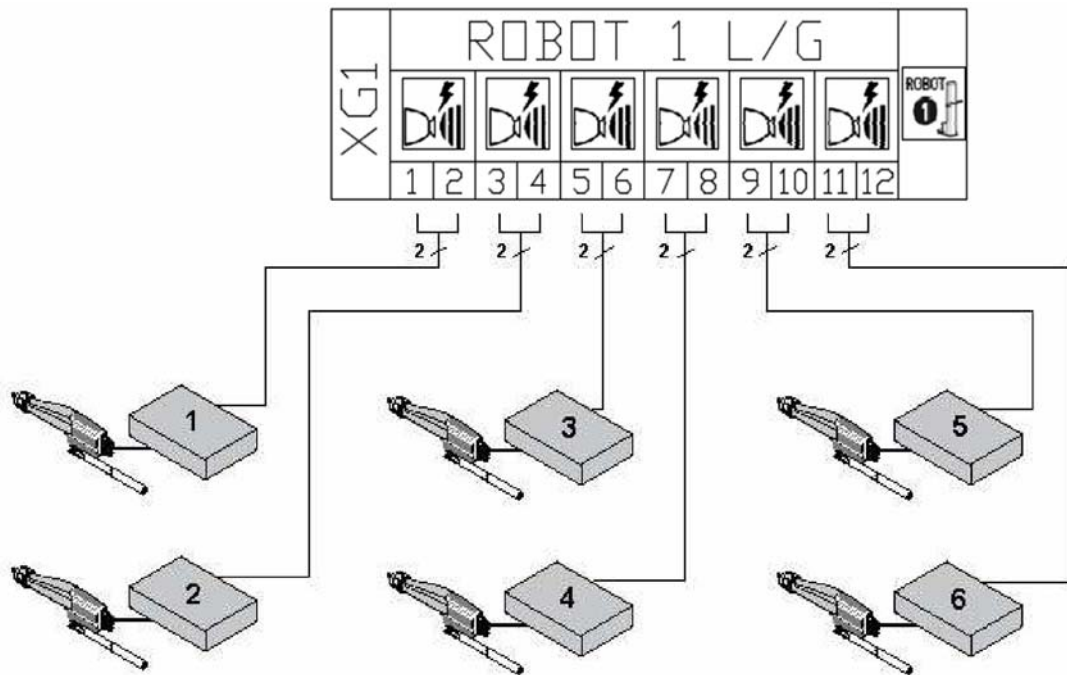

The 6 triggers are controlled individually, according to the plans specified on the operator interface.

XG terminal strip	Spray control
Pin 1	Trigger 1
Pin 2	Trigger 1
Pin 3	Trigger 2
Pin 4	Trigger 2
Pin 5	Trigger 3
Pin 6	Trigger 3
Pin 7	Trigger 4
Pin 8	Trigger 4
Pin 9	Trigger 5
Pin 10	Trigger 5
Pin 11	Trigger 6
Pin 12	Trigger 6

4.5. Interface to the Plant Control System

4.5.1. Electrical Wiring Diagrams

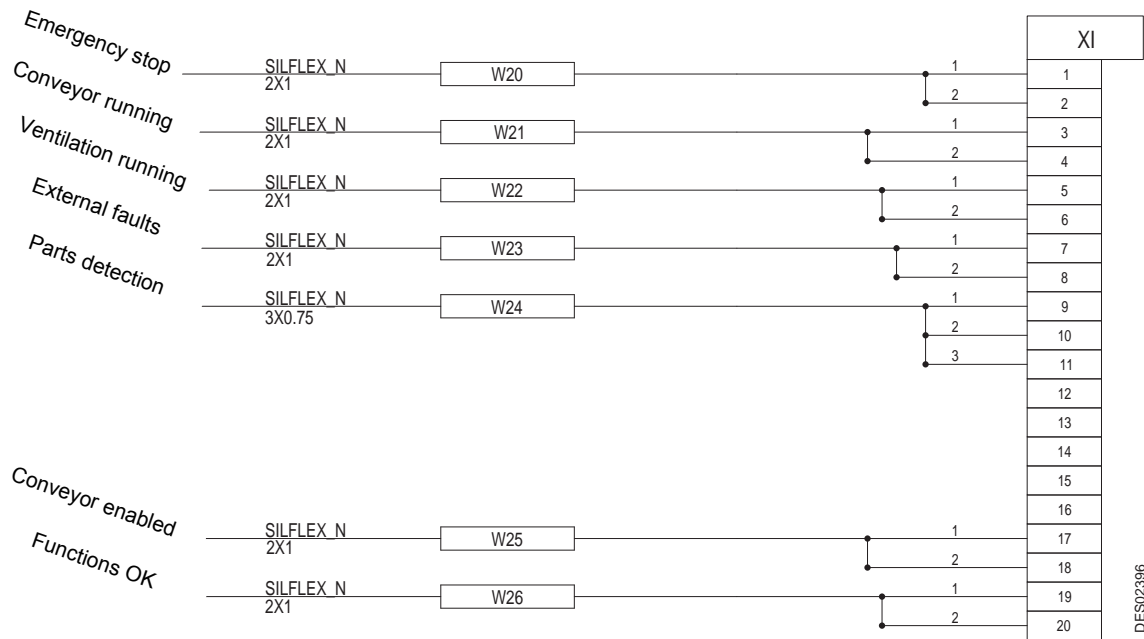

Sames recommends the following cables:

- 2 x 1 mm² (P/N # E2LAAB100)
- 3 x 0.75 mm² (P/N # E2LDAC075)

Each output is a normally open floating contact.

XI Terminal	Interface inputs and outputs
Pin 1	Emergency stop
Pin 2	Emergency stop
Pin 3	Conveyor running (24 Volts)
Pin 4	Conveyor running input Ia.2
Pin 5	Ventilation running (24 Volts)
Pin 6	Ventilation running input Ia.3
Pin 7	External fault (24 Volts)
Pin 8	External fault input Ia.4
Pin 9	Parts detection (24 Volts)
Pin 10	Parts detection (0 Volts)
Pin 11	Parts detection 1 input Ib.0
Pin 12	Parts detection 2 input Ib.1
Pin 13	Parts detection 3 input Ib.2
Pin 14	Parts detection 4 input Ib.3
Pin 15	Parts detection 5 input Ib.4
Pin 16	Parts detection 6 input Ib.5
Pin 17	Conveyor enabled output Qa.5
Pin 18	Conveyor enabled output
Pin 19	Module OK output Qa.4
Pin 20	Module OK output

Terminal XC	Interface inputs and outputs
Pin 1	24 Volts
Pin 2	0 Volt
Pin 3	Conveyor encoder pulse input Ia.5
Pin 4	24 Volts
Pin 5	0 Volt
Pin 6	
Pin 7	
Pin 8	

4.5.2. Control Module

4.5.2.1. Connection of an Additional Emergency Stop Switch



WARNING : If an additional emergency stop switch is not used, pins 1 and 2 on the XI terminal strip must be connected together.

The emergency stop is inserted in series in the control of the power supply relay. It allows to cut the power to the control module and the robots managed by it.

Without emergency stop switch

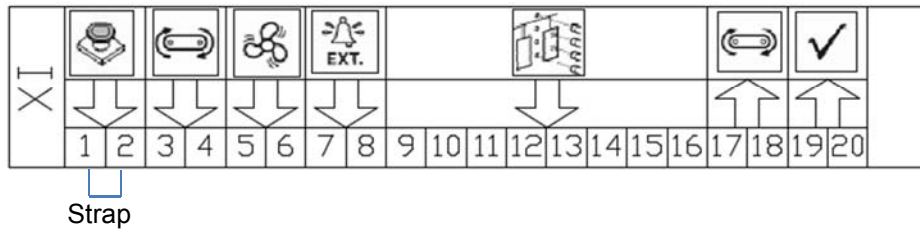

DES06297

With emergency stop switch

The emergency stop system should provide a normally closed floating contact (i.e. the contact opens when operated).

If an emergency stop signal is received, the REV 800 enters 'STOP' mode.

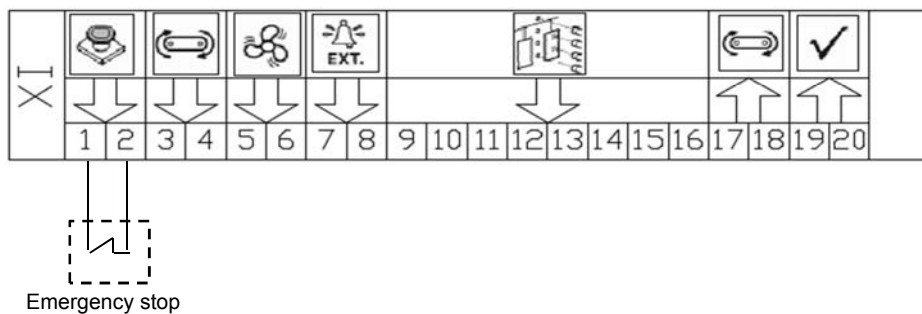

DES06298

Message = Stop on the display.

4.5.2.2. Conveyor Enabled and Conveyor Running Signals - Input pulse encoder

The module may be interfaced with the plant conveyor control system.

Interactive system

In the event of a fault in the REV 800 module, the conveyor is stopped by the module until the fault is acknowledged and cleared.

If the conveyor is stopped, the REV 800 module goes into 'standby' mode with the display showing the 'no conveyor' fault message until the conveyor restarts automatically.

Protocol

When the REV 800 is ready, it sends a 'conveyor enable' signal (floating contact between pins 17 and 18) to the conveyor control system.

The conveyor then starts and the conveyor control system returns a 'conveyor running' signal (floating contact between pins 3 and 4) to the REV 800.

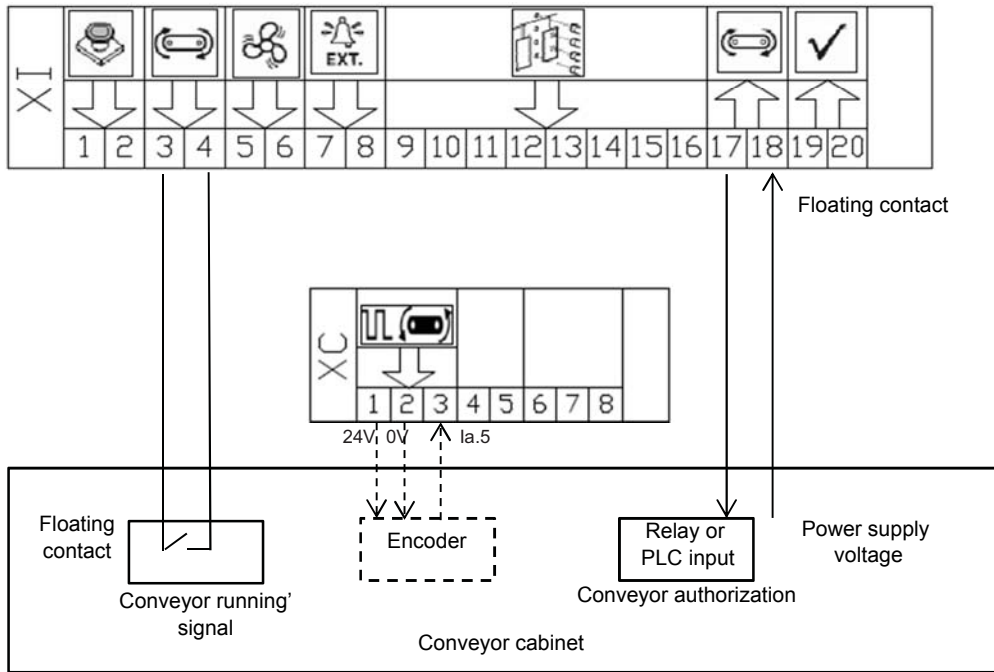

DE506299

It is possible to take into account the actual speed of the conveyor by connecting a conveyor encoder pulse on pins 1-2 and 3 on the XC terminal strip.
 Pins 1 and 2 are used for supplying an encoder or an inductive detector.
 The pin 3 (input REV) receives the conveyor pulse signal.

Note:

If the REV 800 does not receive a 'conveyor running' running signal in automatic mode, it will display a 'no conveyor' error message. The spraying is the cut and the robot sweeping is stopped.

4.5.2.3. Ventilation Running Signal

The module may be interfaced with the plant ventilation control system.

Spraying is only enabled if a 'booth ventilation' signal has been received (floating contact between pins 5 and 6).

If this signal is not present, a 'ventilation fault' message is displayed on the fault view. The sprayers are shut off and the 'conveyor enabled' signal changes state in order to stop the conveyor in automatic mode, the robot sweeping is also stopped.

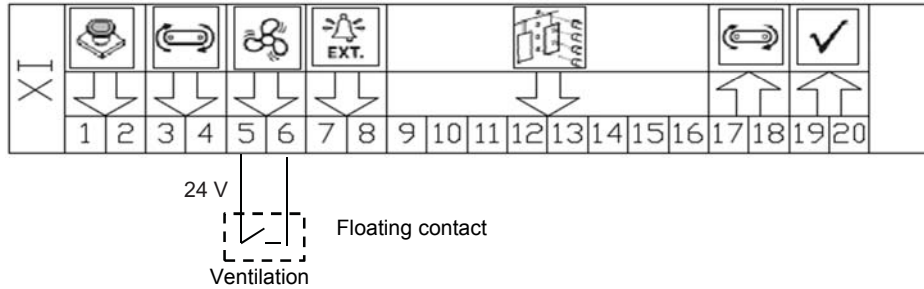

DES06300

Note:

By default, the input is inverted in order to prevent a ventilation fault condition.

4.5.2.4. External Fault Signal

The control module may recognize an external fault signal from another module or cabinet in the plant.

The 'external fault' signal is applied to pins 7 and 8 in the form of a floating contact.

If an external fault is recognized, an 'external fault' message is displayed on the operator interface.

The oscillation of robots is also stopped and in automatic mode, the input " authorization conveyor " change state in order to stop the conveyor and the sprayers are shut off

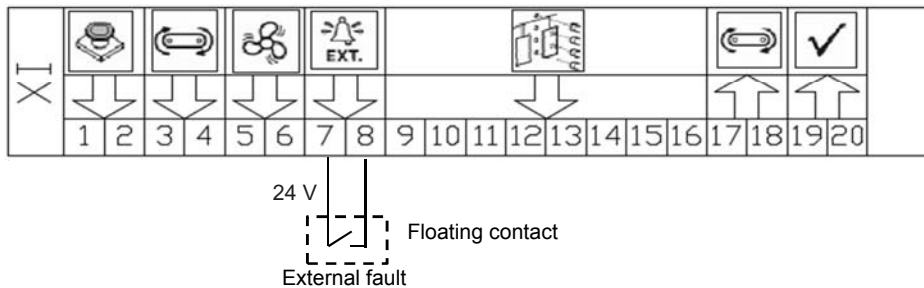

DES06301

Remarks:

Several external fault signals (floating contact) from a number of modules or cabinets in the plant may be connected in series.

By default, the input is configured in order to prevent an external fault condition.

4.5.2.5. Parts Detection

Position detector

The part is detected mechanically by the action of the part to be painted or the suspension arm supporting the part.

The position detector sends a 'part detected' signal via a normally open or normally closed floating contact between pins 9 and 11.

The input may be configured to suit the type of contact (normally open or normally closed).

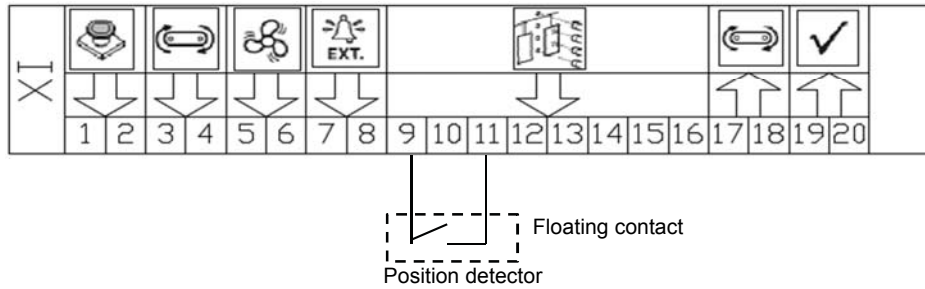

DES06302

Photoelectric detector

The part is detected photoelectrically when the beam is cut by either the part of the suspension arm supporting the part.

The photoelectric cell sends a 'part detected' signal to pin 11.

The input may be configured to suit the type of output from the detector (normally high or normally low).

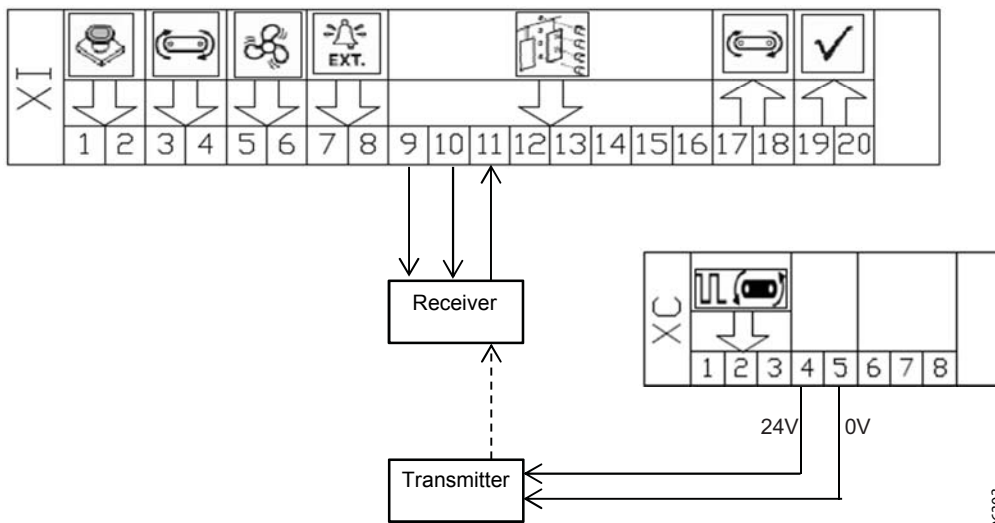

DES06303

By photoelectric barrier or barrier sensing cells

The detection is done photoelectrically by cleavage of the beam with the work piece or the swing supporting the workpiece. The REV 800 module can handle up to 6 informations of altitude"sensing parts" on pins 11 to 16 of the terminal strip XI.

The inputs can be configured to suit the nature of the information (high or low).

The use of a barrier detection allows improved detection of parts compared to the photocells, the detection resolution is smaller on the sensing barrier (50 mm in general).



WARNING : the areas occultation configuration is not managed by the REV module. This setting is done by the programming software of the sensing barrier.

But the user must make a copy of this configuration in the REV800 module.

The photocell barrier is configurable in 6 detection areas and it sends 6 informations of "detection parts" on pins 11 to 16 of the terminal strip XI.

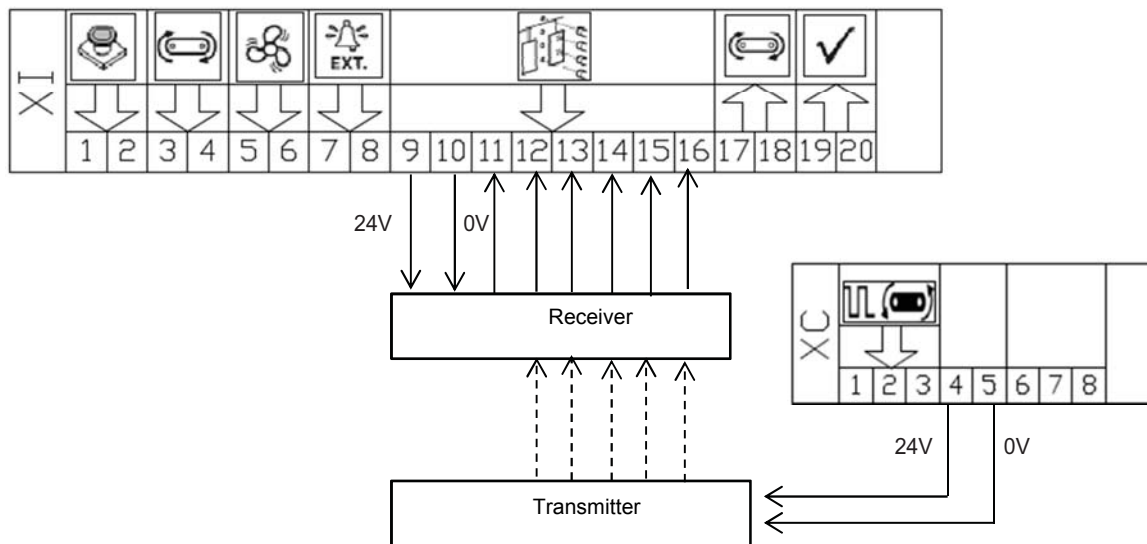

DES06304

4.5.2.6. Control module OK signal

The control module provides a 'control module OK' signal in the form of a floating contact between pins 19 and 20.

This signal may be fed to another module cabinet in the plant via a relay or PLC input.

When the REV 800 is running, this floating contact is normally closed.

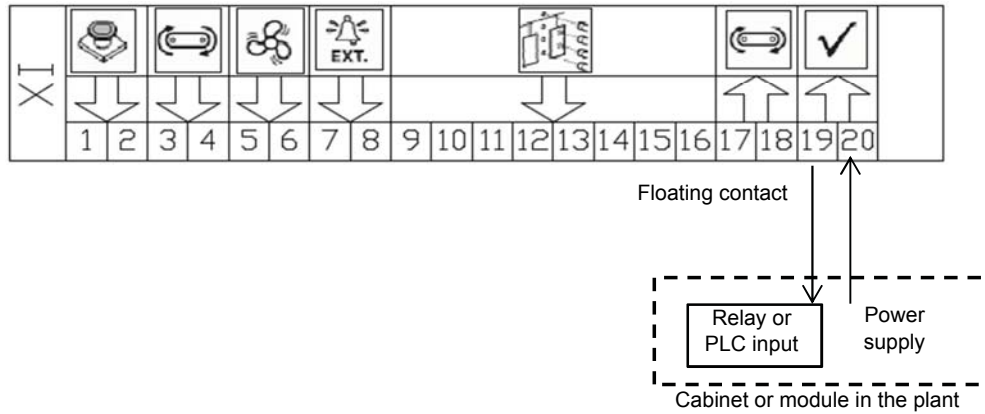

DES06305

5. Spare parts

Part Number	Description	Qty	Sale unit	Maintenance Level for spare parts (*)
910019970	REV 800 Control module	-	1	3
E6GPSR077AT	Barrier Zener	-	1	1
110000966	Connector XP	-	1	3
E4PTRF590	Connector XI	-	1	3
110000967	Connector XC	-	1	3
E4PTRF587	Connector XM1/XM2	-	1	3
E4PTRF588	Connector XG1/XG2	-	1	3

(*)

Level 1: Standard preventive maintenance

Level 2: Corrective maintenance

Level 3: Exceptional maintenance