



From February 1st, 2017 SAMES Technologies SAS becomes SAMES KREMLIN SAS
A partir du 1/02/17, SAMES Technologies SAS devient SAMES KREMLIN SAS

SAMES  **KREMLIN**



User manual

UHT 108 EEx e High Voltage Unit

SAS SAMES Technologies. 13 Chemin de Malacher 38243 Meylan Cedex
Tel. 33 (0)4 76 41 60 60 - Fax. 33 (0)4 76 41 60 90 - www.sames.com

All communication or reproduction of this document, in any form whatsoever and all use or communication of its contents are forbidden without express written authorisation from SAMES Technologies.

The descriptions and characteristics mentioned in this document are subject to change without prior notice.

© SAMES Technologies 2007



WARNING : SAS Sames Technologies is registered with the Ministry of Labour as a training institution.

Throughout the year, our company offers training courses in the operation and maintenance of your equipment.

A catalogue is available on request. Choose from a wide range of courses to acquire the skills or knowledge that is required to match your production requirements and objectives.

Our training courses can be delivered at your site or in the training centre at our Meylan head office.

Training department:

Tel. 33 (0)4 76 41 60 04

E-mail: formation-client@sames.com

SAS Sames Technologies operating manuals are written in French and translated into English, German, Spanish, Italian and Portuguese.

The French version is deemed the official text and Sames will not be liable for the translations into other languages.

UHT 108 EEx e
High Voltage Unit

1. Warnings - - - - -	4
1.1. <i>Marking</i>	4
2. Introduction - - - - -	4
3. Description - - - - -	4
4. Characteristics - - - - -	4
4.1. <i>Electric characteristics</i>	4
4.2. <i>Mechanical Characteristics</i>	5
5. Precautions for Use- - - - -	5
5.1. <i>Installation rules</i>	5
6. Assembly / Disassembly - - - - -	6
6.1. <i>Electric connection</i>	6
6.2. <i>Replacing the low voltage cable</i>	7
6.3. <i>Replacing the high voltage cable</i>	7
6.4. <i>Replacement of a "UHT 108" HVU by a "UHT 108 EEx e" high voltage unit</i>	8
7. Spare parts- - - - -	9
7.1. <i>High voltage unit "UHT 108 EEx e"</i>	9
7.2. <i>Cables</i>	10
7.3. <i>Preparing of the high voltage cable</i>	11

1. Warnings



WARNING : This equipment may become a safety hazard if it is not operated, disassembled and reassembled in accordance with the instructions given in this user manual.

See the equipment manual.

1.1. Marking

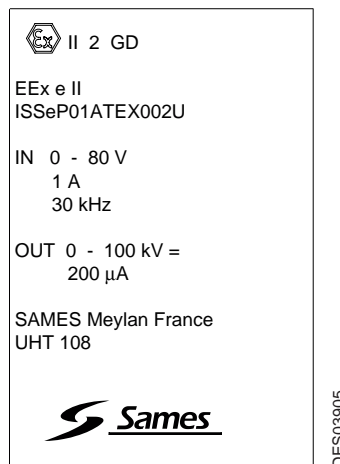

2. Introduction

The high voltage unit **UHT 108 EEx e** is a high voltage unit of general using and can be equipped with one or two high voltage cables.

3. Description

The high voltage **UHT 108 EEx e** comprises :

- Overmolded units containing:
 - The high voltage items (transformer, cascade, measuring resistor and damping resistor),
 - The low voltage items (recognition resistor and protection devices),
 - Two high-voltage connectors, one of which is equipped to receive the high-voltage cables.
 - A low voltage connector.

4. Characteristics

4.1. Electric characteristics

	UHT 108 EEx e
Maximum input voltage	80 V max. 30 Khz
Output voltage	100 kV
Output current	200 μA
Polarity	Negative

4.2. Mechanical Characteristics

The UHT 108 EEx e is delivered without low- and high-voltage cables.

	UHT 108 EEx e
Overall dimensions	260 x 125 x 55
Weight	3 Kg
Packing	1 box 300 x 270 x 75

5. Precautions for Use

- Clean and grease the high voltage well with dielectric grease before fitting.
- Never fit or remove with the power switched on.
- Do not bring the low-voltage cable into contact with solvents.
- The length of the cable between the high-voltage unit and the GNM 200 generator is 30 m.
- HV connection of the atomizer to the well of the high voltage unit is authorized only by the use of a HV cable, only one length, no adapter is not authorized. The overall length of the HV cables (electric capacities) interfere over the time of discharge of the equipment (HVU, atomizer, HV cable) which must respect the lawful requirement E (energy) < 350 mJ in less than two seconds.
- When flammable products are used, spacing between the objects to be painted and the parts under high voltage of the system must be sufficiently large so that a spark of rupture is avoided under the operating conditions, lawful requirement.



WARNING : The control module GNM must be placed in a anti-fire area at least 1,5 m (4.9 feet) from the nearest opening of the booth.

5.1. Installation rules

The overall length of the HV cables (electric capacities) interfere over the time of discharge of the equipment (HVU, atomizer, HV cable) which must respect the lawful requirement E (energy) < 350 mJ in less than two seconds.

A resistance of discharge (Ref.: 910001234) is available in option. It uses one of the high voltage wells and must be connected to the ground. This resistance of discharge is effective until a length of high voltage cable of maxi. 9 m.



WARNING : It is strictly forbidden to install an unspecified system not complying with the rules described above.

6. Assembly / Disassembly

6.1. Electric connection

Cable diameter: = CEE 0,5 mm² or 0,34 mm²

Cable diameter: US = Gauge AWG 20 or AWG 22

Item	Color	Section
A	Yellow	0,34 mm ²
B	Green	0,34 mm ²
C	White	0,5 mm ²
D	Brown	0,5 mm ²
E	Pink	0,34 mm ²
F	Grey	0,34 mm ²

The cable used for the connections must respect:

- wire diameter comprised between 0,3 mm² and 0,8 mm².
- diameter mini. 4 mm and maxi. 8 mm.
- a complete shielding and a second shielding protecting each pair of wires.

Note : Should some wires are not used, they should be connected to the ground.

UHT 108

GNM 200

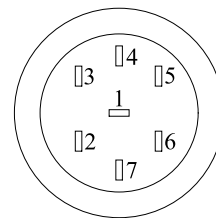
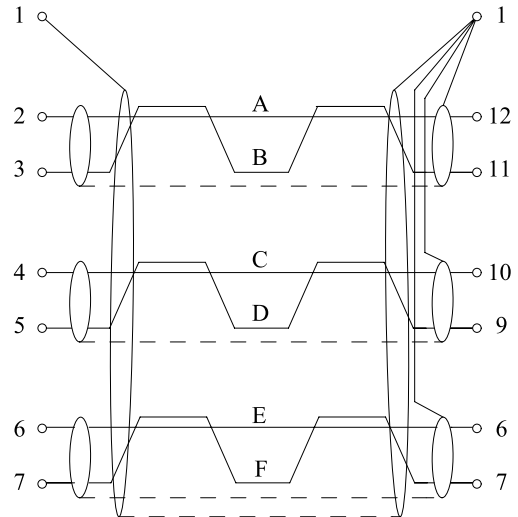

DES03405

6.2. Replacing the low voltage cable

- 1 Maintaining the body of the stuffing box (item 2) loosen the stuffing box nut (item 1) to unlock the cable.
- 2 Unscrew the union of the stuffing box (item 3) in order to access to the connection.
- 3 Unplug each wire.
- 4 Replace the cable.
- 5 Replace the seal washer if necessary ([see § 7.1 page 9](#) Item 1).
- 6 For the reassembly, proceed in reverse order.

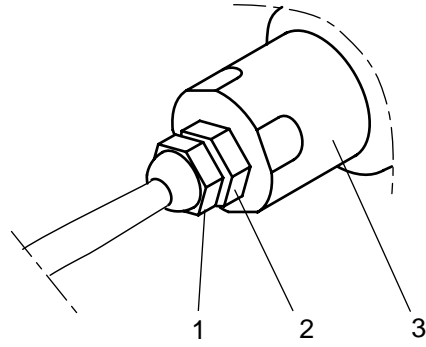

DES01555

6.3. Replacing the high voltage cable

- 1 Maintaining the body of the stuffing box (item 2) loosen the stuffing box nut (item 1) to unlock the cable.
- 2 Remove the cable.
- 3 Replace the cable. For the preparing of the high voltage cable ([see § 7.3 page 11](#)).
- 4 For the reassembly, proceed in reverse order.

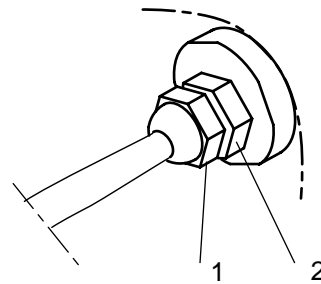

DES03407

6.4. Replacement of a "UHT 108" HVU by a "UHT 108 EEx e" high voltage unit

For the replacement of a high voltage unit "UHT 108", it will imperatively be necessary to respect the adaptation of the low voltage connection described below.

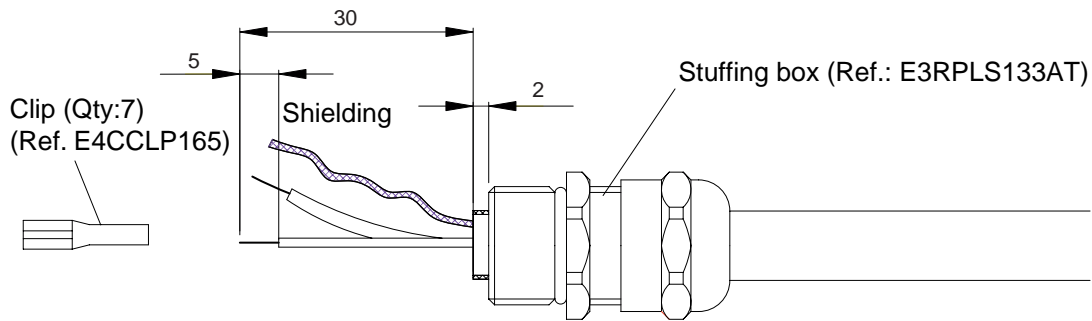

DES03419

Preparing the cable

- Decad the cable on approximately 30 mm.
- Strip the wires on approximately 5 mm.
- Insulate the shielding with the sheath.
- Crimp the clips on the six wire and the shielding using a grip having the same reference mark color than the selected thimble.

Connection to the high voltage unit: Correspondance between the two high voltage units

UHT 108 connection	UHT 108 EExe connection
1	7
2	2
3	3
4	4
5	5
6	6
	1 = general shielding

The parts necessary to the adaptation of the low voltage connection are provided with the "UHT 108 EEx e" high voltage unit.

7. Spare parts

7.1. High voltage unit "UHT 108 EEx e"

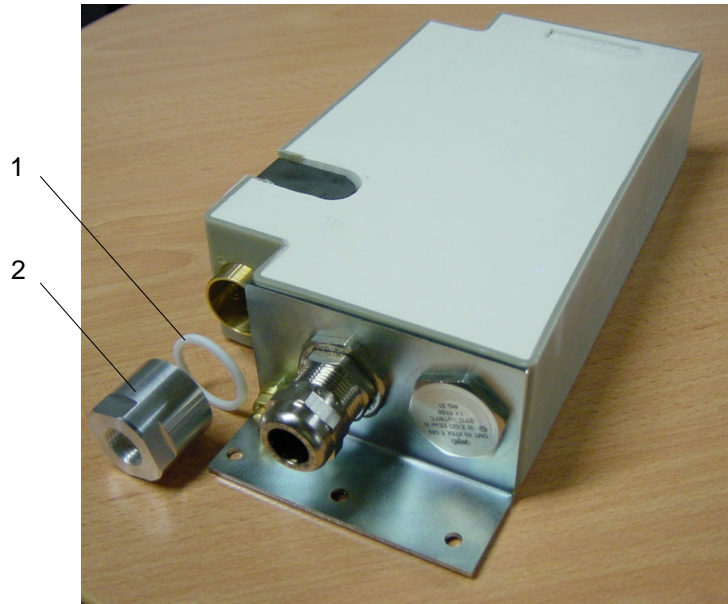

Item	Part number	Description	Qty	Sale unit	First Emergency	Consumable
	910001285	"UHT 108 EEx e" high voltage unit	1	1	X	
1	1408523	Seal washer	1	1		X
2	1310068	Stuffing box union	1	1		X

7.2. Cables

Note: Each cable has a defined length, for other lengths, please, contact Sames Technologies.

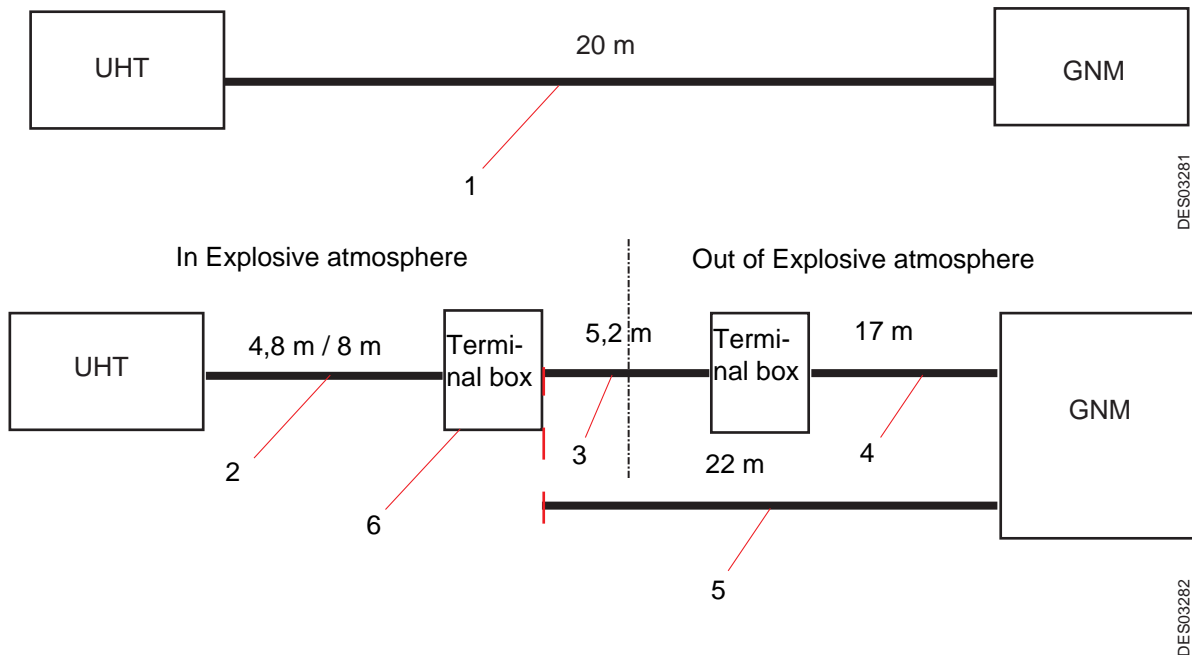

Item	Part number	Description	Qty	Sale Unit	First Emergency	Consumable
1	1514591	Equipped low voltage cable, Length: 20 m	1	1	-	-
2	1527252	Low voltage cable, Length: 4.8 m (HVU to terminal box)	1	1	-	-
	910001236	Low voltage cable, Length: 8 m (HVU to terminal box)	option	1	-	-
3	910000086	Low voltage cable, Length: 5.2 m	1	1	-	-
4	910000070	Low voltage cable, Length: 17 m (Connection terminal box to GNM)	1	1	-	-
5	1520516	Low voltage cable, Length: 22 m (Connection terminal box to GNM)	1	1	-	-
6	1303899AT	Terminal box	1	1	-	-



WARNING : Cable length between the high voltage unit and the control module GNM should not exceed 30m.

7.3. Preparing of the high voltage cable



WARNING : Ensure not to damage the insulating jacket. The smallest nick or mark in the insulating jacket will cause the cable to breakdown.

Preparing:

- Strip the external sheath side HVU with a tool of the type strip-cable (rice grain). It is imperative not to use a standard tool slicing "cutter".
- Strip the semiconductor sheath by peeling it and cut it using cutting pliers.



WARNING : At the time of the installation of the HV cable in the high voltage unit, coat with dielectric grease the screwed end piece and take care not to tear the semiconductor sheath with the stuffing box and to maintain the cable with a sufficient radius of curvature to avoid tearing the sheath.

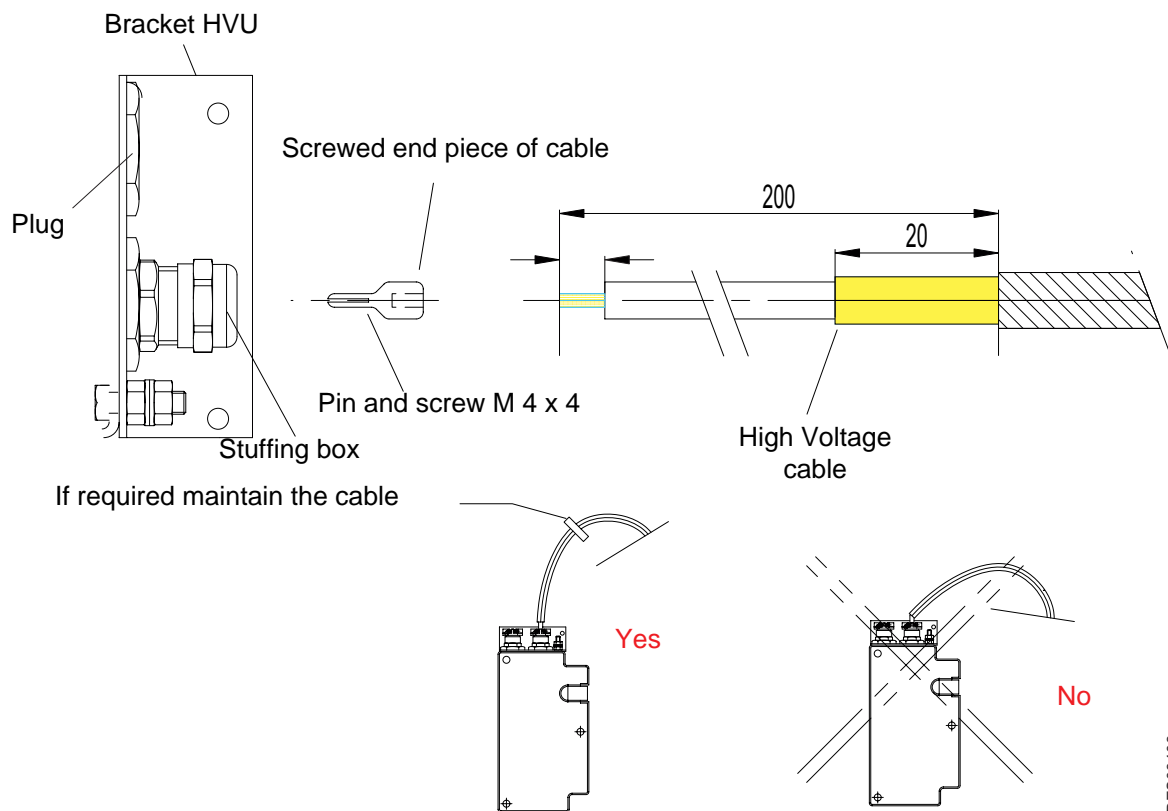

Part Number	Description	Qty	Sale Unit
910001977	Kit for second output	1	1



WARNING : If only one well of the high voltage unit is used, the well not used must be sealed by a plug (ref.: 110000129AT) provided with the HVU.