



From February 1st, 2017 SAMES Technologies SAS becomes SAMES KREMLIN SAS  
A partir du 1/02/17, SAMES Technologies SAS devient SAMES KREMLIN SAS



# User manual

## Robot Control Module REV 600 Installation Manual

**SAMES Technologies.** 13 Chemin de Malacher 38243 Meylan Cedex  
Tel. 33 (0)4 76 41 60 60 - Fax. 33 (0)4 76 41 60 90 - [www.sames.com](http://www.sames.com)

All communication or reproduction of this document, in any form whatsoever and all use or communication of its contents are forbidden without express written authorisation from SAMES Technologies.

The descriptions and characteristics mentioned in this document are subject to change without prior notice.

© **SAMES Technologies 2003**



**WARNING :** SAS Sames Technologies is registered with the Ministry of Labour as a training institution.

Throughout the year, our company offers training courses in the operation and maintenance of your equipment.

A catalogue is available on request. Choose from a wide range of courses to acquire the skills or knowledge that is required to match your production requirements and objectives.

Our training courses can be delivered at your site or in the training centre at our Meylan head office.

**Training department:**

**Tel. 33 (0)4 76 41 60 04**

**E-mail: [formation-client@sames.com](mailto:formation-client@sames.com)**

**SAS Sames Technologies** operating manuals are written in French and translated into English, German, Spanish, Italian and Portuguese.

The French version is deemed the official text and Sames will not be liable for the translations into other languages.

Robot Control Module  
REV 600  
Installation Manual

1. Health and Safety Instructions - - - - -	4
2. Description - - - - -	5
3. Installation - - - - -	7
3.1. <i>Description</i> . . . . .	7
3.2. <i>Operating Conditions</i> . . . . .	11
3.3. <i>Cleaning and Maintenance of the Touch Panel</i> . . . . .	11
3.4. <i>Mechanical Characteristics</i> . . . . .	12
3.4.1. <i>General Characteristics of the Module.</i> . . . . .	12
3.4.2. <i>Dimensions of the Module (uncased)</i> . . . . .	12
3.4.3. <i>Dimensions of the Module (cased)</i> . . . . .	13
3.4.4. <i>Installation of the module in the case.</i> . . . . .	13
3.5. <i>Electrical Characteristics</i> . . . . .	13
3.5.1. <i>Characteristics of the Module</i> . . . . .	13
3.5.2. <i>Connectors.</i> . . . . .	14
3.5.3. <i>Inputs</i> . . . . .	14
3.5.4. <i>Outputs</i> . . . . .	15
3.5.5. <i>24V DC Power Supply</i> . . . . .	17
3.6. <i>General Installation Diagram</i> . . . . .	18
3.6.1. <i>Robot</i> . . . . .	18
4. Connections - - - - -	20
4.1. <i>Ground Connection</i> . . . . .	20
4.2. <i>Connecting the Mains Supply to the Module</i> . . . . .	20
4.2.1. <i>Electrical Wiring Diagrams.</i> . . . . .	20
4.2.2. <i>Control Module.</i> . . . . .	20
4.3. <i>Connections to the RFV 2000 Robots</i> . . . . .	21
4.3.1. <i>Electrical Wiring Diagrams.</i> . . . . .	21
4.3.2. <i>Control Module.</i> . . . . .	22
4.4. <i>Connections to the Spray Triggers</i> . . . . .	25
4.4.1. <i>Electrical Wiring Diagrams.</i> . . . . .	25
4.4.2. <i>Control Module.</i> . . . . .	26
4.5. <i>Interface to the Plant Control System</i> . . . . .	27
4.5.1. <i>Electrical Wiring Diagrams.</i> . . . . .	27
4.5.2. <i>Control Module.</i> . . . . .	28
5. Spare parts- - - - -	32

## 1. Health and Safety Instructions



**WARNING :** This equipment may be hazardous when not used following the safety rules described in this manual:

- The REV 600 module is intended to be installed in a control cabinet made by Sames Technologies which provides the basic level of sealing of the product from its environment (water splashes, pollution from powder and from dust...). Any utilisation other than prescribed by Sames remains the sole responsibility of the end user (like when used outside of a control cabinet, or installed in an electrical cabinet not made by Sames Technologies).
- The REV 600 module must be installed outside of ATEX zones.
- The REV 600 module must be installed away from the powder polluted area.
- The REV 600 module cannot be installed out of doors.
- Ambient temperature in the vicinity of the REV 600 modules must be lower or equal to 40 C degrees.
- The REV 600 module must be connected to the shop's earth via a green/yellow wire of an at least 6mm<sup>2</sup> section.
- The REV 600 module must not be used without its cover.
- The REV 600 module must not be modified from its original design.
- Only Sames Technologies spare parts, or a repair carried out by the repair department of Sames will ensure and ascertain the safe operation of the REV 600 module.
- Switch off the electrical power to the REV 600 module prior to pulling off its connectors.
- The "booth ventilation ON" information must be connected to the REV 600 module in order to allow spraying only while the booth ventilation is turned on. Should this connection not be established, the operation of the system falls entirely under the responsibility of the end user.
- The touch-screen of the REV 600 module is designed for use with clean or protected hands. There is a protective film to be installed on the screen area. The warranty does not cover pollution of the touch-screen of the REV 600 module by powder paint.
- The REV 600 module is exclusively designed to operate a Sames Technologies RFV series reciprocator, which must be installed in an ATEX zone.  
Any other utilisation of the reciprocator falls under the sole responsibility of the end user.
- The REV 600 module is designed to be used only in conjunction with the potentiometers installed by Sames on the RFV series reciprocators. This whole electrical system is certified by Sames, and guarantees that the potentiometer can be used in an ATEX zones.
- The thermal probe of the RFV's motor must be connected to the REV 600 module in order to guarantee the utilisation of the RFV in an ATEX zone.
- Any intervention on the REV 600 module under voltage has to be made only by personal authorized and formed to the electrical interventions .

## 2. Description

The **REV 600** control module is capable of controlling up to two Sames **RFV 2000** robots. It is used to control the up and down vertical oscillation that has been programmed for each of the robots to suit the characteristics of the part being processed.

The motion of each robot may be different. This motion is divided into three distinct zones.

Each of these zones may be programmed to a different oscillation speed with the spray enabled or disabled.

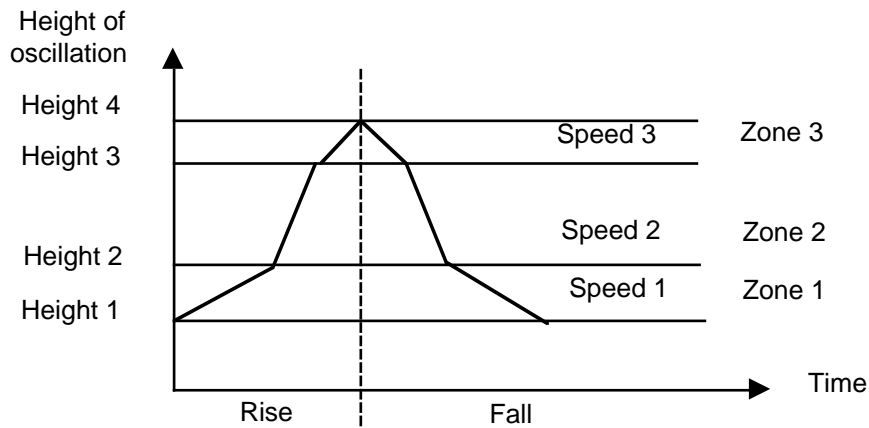

The module also controls the triggering of up to twelve Sames spray guns or sprayers via a Sames spray module. These may be used with either liquid paint or powder.

The module is easy to interface to a plant control system using the following functions:

- Automatic spraying when parts are detected by a sensor or photocell.
- Input provided for an emergency stop switch if required.
- External fault input.
- External fault output.
- Ventilation running input
- Conveyor running input.
- Conveyor control output.

The REV 600 is a 19 inch rack-mountable unit intended to be housed in a Sames FCR modular cabinet together with various Sames 19 inch spray modules.

It may also be used as a stand-alone unit, housed in a Sames installation cabinet.



**WARNING :** The REV 600 module must be imperatively installed outside of ATEX zones and in an atmosphere not polluted by residues of powder or liquid paints.

**Block diagram of the system**

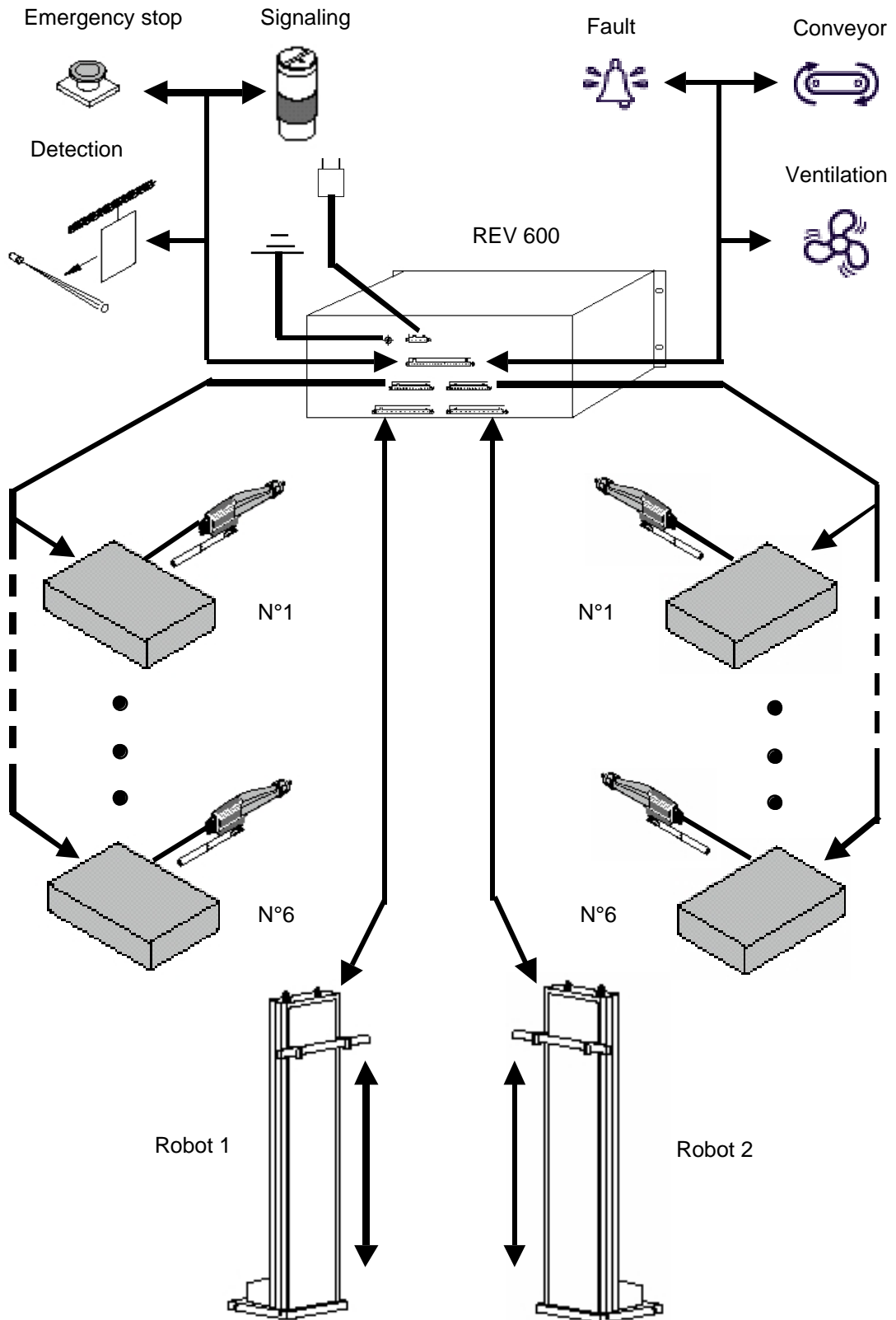

**Note:** [see § 4 page 20](#) for the details of the connections.

### 3. Installation

#### 3.1. Description

The architecture of the REV 600 module is based on a programmable logic controller, a touch-sensitive operator control panel and two speed converters.

#### Layout (from above)

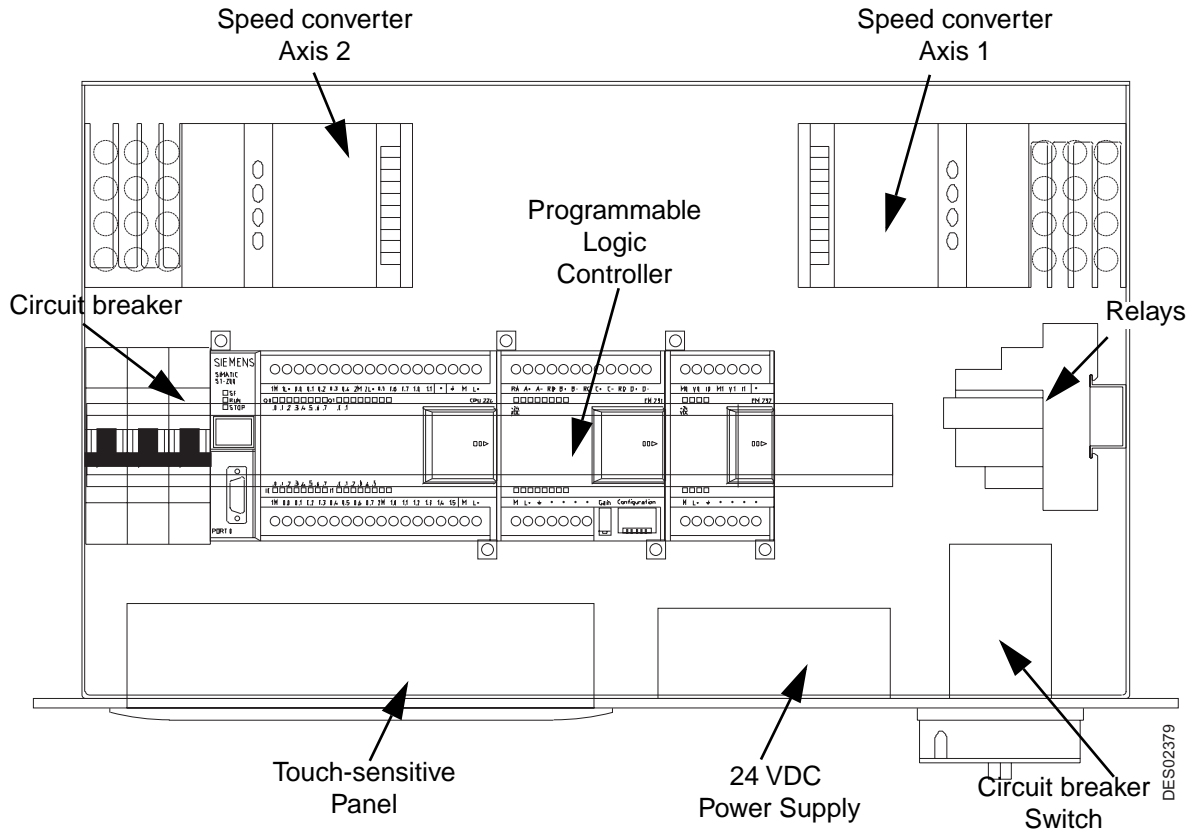

**The Programmable Logic Controller (PLC)** consists of the following three modules:

- CPU module with integrated digital logic signal inputs and outputs.
- Analog input module
- Analog output module

The digital logic signal inputs and outputs are used primarily for:

- Interfacing with the plant control system.
- Controlling the triggering of the spray guns or sprayers.
- Transmitting data specific to the module.

The analog inputs are used to acquire positional data from the rotational potentiometers on each axis.

The analog outputs are used to transmit a speed demand signal to the speed converters.

**The speed converters** are used to:

- Supply a reference voltage to the rotational potentiometers.
- Drive the induction motor actuators on the RFV 2000 robots.

**The graphical Touch Panel** operates together with the Programmable Logic Controller to provide the Man-Machine Interface for the module.

A **24 VDC power supply unit** supplies power to the various PLC modules.

**The circuit breaker switch** is used to isolate the robots during maintenance operations by cutting the power supply to the speed converters.

**The relay block** is used to:

- Interface the triggering signals to the spray guns or sprayers.
- Exchange data specific to the module.

A protective **circuit breaker** is included in the power supply in order to protect the module.

#### Front panel



Touch-sensitive STN operator screen (5.6 inches with four levels of blue)    Circuit breaker switch

All interfacing between the operator and the module is provided by the graphical Touch Panel connected to the Programmable Logic Controller:

- 5.6 inch STN screen, backlit by CCFL. The screen is easy to read even under difficult lighting conditions.
- Cold Cathode Fluorescence Lamps
- Resistive analog touch-sensitive screen, controlled by a finger, non-pointed object or glove.
- Strong plastic case, protected to IP54 (front panel) and IP20 (rear panel).

The circuit breaker switch is used to cut off the power supply to the RFV2000 robots during maintenance operations.

The switch may be locked using a padlock.



**WARNING :** Even when the switch is in position 0, power continues to be supplied to the operator control panel. However, it is not possible to drive the movement of the robots or trigger the sprayers electrically (stop mode).

**When the switch is activated to 1, installation passes in manual or automatic mode.**

**Before putting the switch on position 1, the operator must ensure that nobody is in the working area of the installation.**

**Non the respect of this instruction is under the responsibility of the user.**





**WARNING :** If not used for five minutes, the screen enters screen-saver or stand-by mode and appears to be switched off. Touching the screen will bring it out of stand-by mode immediately.

An optional protective film (P/N # E1AAUZ090) is available for the screen.  
This film prevents scratching or damage to the screen.

#### Rear view

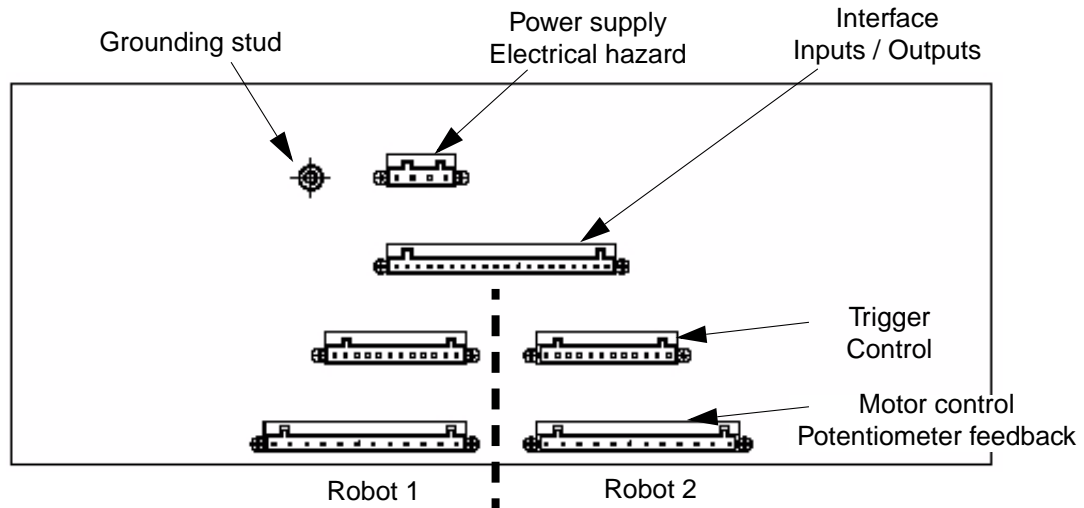

Connections are made to the system via connectors with spring-loaded terminals. Ferrules should not be used on the connecting wires as this method provides a tight vibration-resistant connection.

The connectors are locked in position by means of catches. These are easy to use and no tools are required.

Each individual connector can only be inserted in one orientation.

Each female connector is fitted with a handle and cable clamp preventing any tension on the individual wires as the connector is withdrawn.

The power and speed converter connectors have a pitch of 7.5 mm. The control signal connectors have a pitch of 5.08 mm.

**Signalitic plate of the equipment**

	
SAMES	
TYPE:	REV 600
SAMES REF.: 1523227	
Input voltage: 230V (Mono/Tri) +/- 10%	
Input frequency: 47-63 Hz	
Input current: 16 A	
Serial N°	<input type="text"/>
Date	<input type="text"/>
Software	<input type="text"/>

### 3.2. Operating Conditions

Ambient temperature	< 45°C
Relative humidity	< 85% non-condensing
Altitude	< 1000m (Speed converters must be derated above this level)
Environment	Non-explosive

### 3.3. Cleaning and Maintenance of the Touch Panel Scope

The control panel screen is designed to operate with the minimum of maintenance. Regular maintenance is limited to cleaning the screen.

#### Cleaning the screen

##### Preparation

The control panel screen should be cleaned periodically.  
Clean the screen using a damp cloth. Switch off the equipment before cleaning the screen. This will eliminate any chance of selecting unwanted operations.

##### Clean display

If the equipment includes a 'Clean display' function, you may clean the screen while the timer bar is active without the risk of selecting any other functions. All input from the screen is disabled during this period.

##### Protective film

An optional protective film is available for the screen.  
This film prevents scratching or damage to the screen.

##### Cleaning products

Dampen the cloth with water and a mild detergent (washing-up liquid) or a foam product specially designed for cleaning screens. Spray the cleaner onto the cloth, never directly onto the screen. Do not use aggressive solvents or abrasive cleaners.



**WARNING :** Touch Panel should not be put in contact with liquid products or powders otherwise there is a risk of damaging it.

### 3.4. Mechanical Characteristics

#### 3.4.1. General Characteristics of the Module

Uncased:

Rack mounted	19 inch
Height	4 U
Protection index	IP20 (case), IP 54 (front panel)
Weight	11.2 kg

Cased:

Protection index	IP54
Weight	21.7 kg

#### 3.4.2. Dimensions of the Module (uncased)

##### Front panel

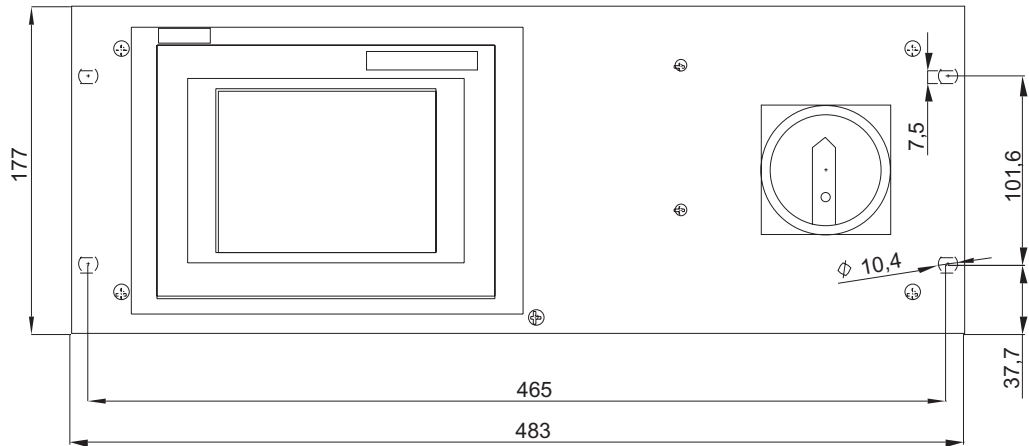

DES02376

##### Rear panel

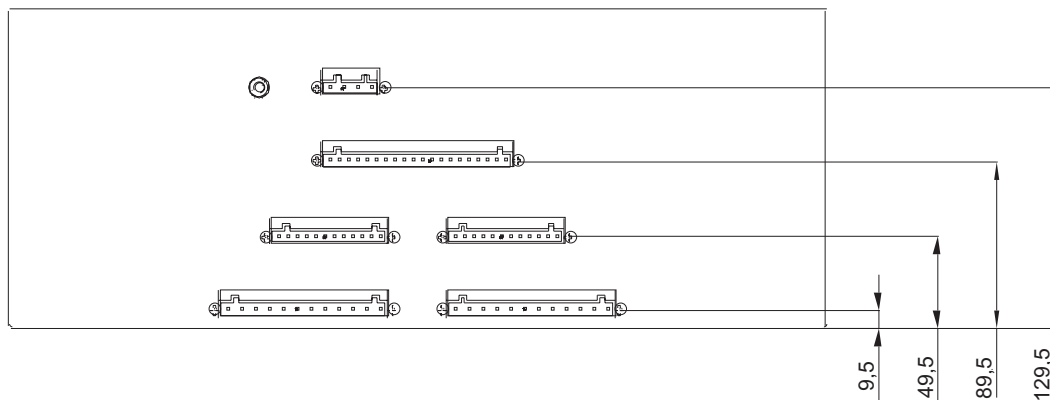

DES02377

## View from above

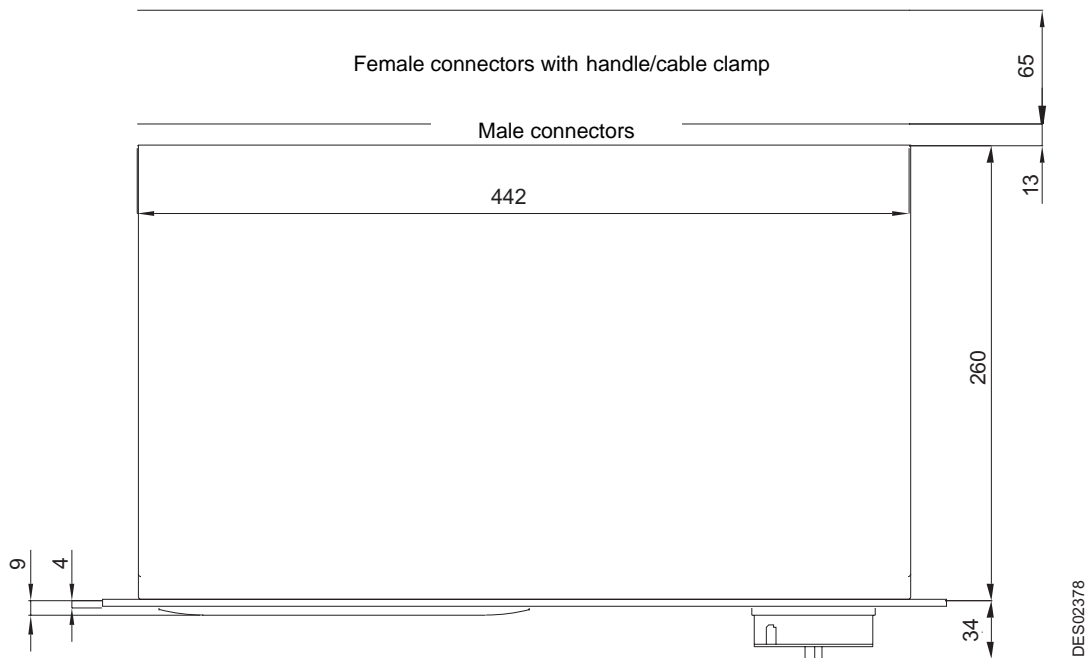

### 3.4.3. Dimensions of the Module (cased)

	Dimensions	Overall
Width	525 mm	
Height	227 mm	240 mm
Depth	408 + 8 mm	+25 mm

### 3.4.4. Installation of the module in the case

- **Step 1:** Fix the REV 600 on the front face of the case.
- **Step 2:** Connect the ground wire (yellow/green) between the case and the REV 600.
- **Step 3:** Connect the REV 600 to the installation. Pass the cables through the stuffing boxes and connect them to the connectors of the REV 600. Tighten correctly the stuffing boxes.
- **Step 4:** Screw the front face on the case by taking care to have a sufficient sealing.

## 3.5. Electrical Characteristics

### 3.5.1. Characteristics of the Module

Input voltage	230 single / three phase ( $\pm 10\%$ )
Frequency range	47-63 Hz
Input current (max.)	16 A

### 3.5.2. Connectors

<b>Connectors with a pitch of 7.5 mm</b>	
Maximum voltage	300 V
Maximum current	15 A
Nominal conductor size	0.08 to 205 mm <sup>2</sup>

<b>Connectors with a pitch of 5.08 mm</b>	
Maximum voltage	300 V
Maximum current	10 A
Nominal conductor size	0.08 to 2.5 mm <sup>2</sup>

### 3.5.3. Inputs

#### 3.5.3.1. Digital Logic Signal Inputs

<b>General</b>	<b>24 V Inputs</b>	
Type	P/N (CEI type 1 in P mode)	
Nominal voltage	24 V at 4 mA (typ.)	
Maximum permissible continuous voltage	30 V	
Transient voltage	35 V for 0.5 seconds	
Logical '1' (min.)	15 V at 2.5 mA	
Logical '0' (max.)	5 V at 1 mA	
Input delay	Selectable (0.2 to 12.8 ms)	
Two-wire proximity detector (Bero) Permissible leakage current (max.)	1 mA	

<b>General</b>	<b>24 V Inputs</b>	
Galvanic isolation (site to logic inputs)	Yes 500 V for 1 minute	
Input signal frequency (max.) Logical '1' = 15 to 30 V Logical '1' = 15 to 26 V	Single-ended 20 kHz 30 kHz	Bipolar 10 kHz 20 kHz
Maximum number of inputs simultaneously at '1'	All at 55°C	
Cable length (max.) Screened Unscreened	500 m (normal inputs), 50 m (HSC inputs) 300 m (normal inputs)	

### 3.5.3.2. Analog Inputs

<b>General</b>	
Data word format	
Bipolar full scale	- 32000 to + 32000
Unipolar full scale	0 to 32000
Short circuit input impedance	Voltage input $\geq 10 \text{ M}\Omega$ Current input $250 \Omega$
Input filter attenuation	-3 db at 3.1 kHz
Maximum input voltage	30 V
Maximum input current	32 mA
Resolution	12-bit A/D converter
Isolation (site / system)	None
Type	Differential input
Ranges	
Voltage (unipolar)	0 to 10 V
Input resolution	
Voltage (unipolar)	2.5 mV
Analog-digital conversion time	< 250 $\mu\text{s}$
Analog impulse response	1.5 ms at 95 %
Common mode rejection	40 dB at 60 Hz (input shorted)
Common mode voltage	Signal voltage + common mode voltage must be $\leq \pm 12 \text{ V}$
24 V power supply range	20.4 to 28.8 V

### 3.5.4. Outputs

#### 3.5.4.1. Relay Outputs

##### **Floating contact**

Nominal / maximum switched voltage	250/250 V AC
Nominal / maximum current	8 A / 15 A
Nominal load	2000 VA
Nominal load (230 VAC)	400 VA
DC1 switching current	30 / 110 / 220V: 8 / 0.3 / 0.12 A
Minimum switched load	300 mW (5 V / 5 mA)
Contact material	AgNi

Mechanical life (AC / DC)	10 000 000 / 20 000 000 cycles
Electrical life (full load AC1)	100 000 cycles
Response time (pull-in / release)	10 / 10 ms
Dielectric strength (contacts open)	1000 V AC

### 3.5.4.2. Transistor Logic Signal Outputs

General	24V Outputs
Type	MOS transistor <sup>1</sup>
Nominal voltage	24V
Voltage range	20.4 to 28.8 V
Surge current (max.)	8 A for 100 ms
Logical '1' (min.)	20 V at maximum current
Logical '0' (max.)	0.1 V with a load of 10 k $\Omega$
Nominal current per output (max.)	0.75 A
Nominal neutral current (max.)	6 A
Leakage current (max.)	10 $\mu$ A
Lamp load (max.)	5 W
Inductive cut-off voltage	L+ less 48 V, dissipation 1 W
Contact resistance (closed)	0.3 $\Omega$ max.
Galvanic isolation (site / system) System / contact Contact / contact Resistance (system / contact) Isolation groups	500 V for 1 minute    See wiring diagram
Delay Pull-in / release (max.) Switching (max.)	2/10 $\mu$ s (Q 0,0 and Q 0,1) 15/100 $\mu$ s (all others)
Switching frequency (max.) Q 0,0 and Q 0,1	20 kHz
Mechanical lifetime	
Contact lifetime	
Maximum number of outputs simultaneously at '1'	All at 55 °C
Connection of two outputs in parallel	Yes
Cable length (max.) Screened Unscreened	500 m 150 m



### 3.5.4.3. Analog Outputs

<b>General</b>	
Isolation (site / system)	None
Signal range Voltage output Current output	$\pm 10$ V 0 to 20 mA
Resolution (full scale) Voltage Current	12 bits 11 bits
Data word format Voltage Current	- 32000 to + 32000 0 to + 32000
Accuracy Worst case, 0°C to 55°C Voltage output Current output Typical, 25°C Voltage output Current output	$\pm 2$ % of full scale $\pm 2$ % of full scale $\pm 0.5$ % of full scale $\pm 0.5$ % of full scale
Settling time Voltage output Current output	100 $\mu$ s 2 ms
Maximum excitation Voltage output Current output	5000 $\Omega$ minimum 500 $\Omega$ maximum

### 3.5.5. 24V DC Power Supply

Switched mode power supply, protected against short circuit, overload and overvoltage.

Output voltage	24 VDC
Tolerance	$\pm 1$ %
Maximum current	2.5 A
Power	60 W
Efficiency	79 %

### 3.6. General Installation Diagram

#### 3.6.1. Robot

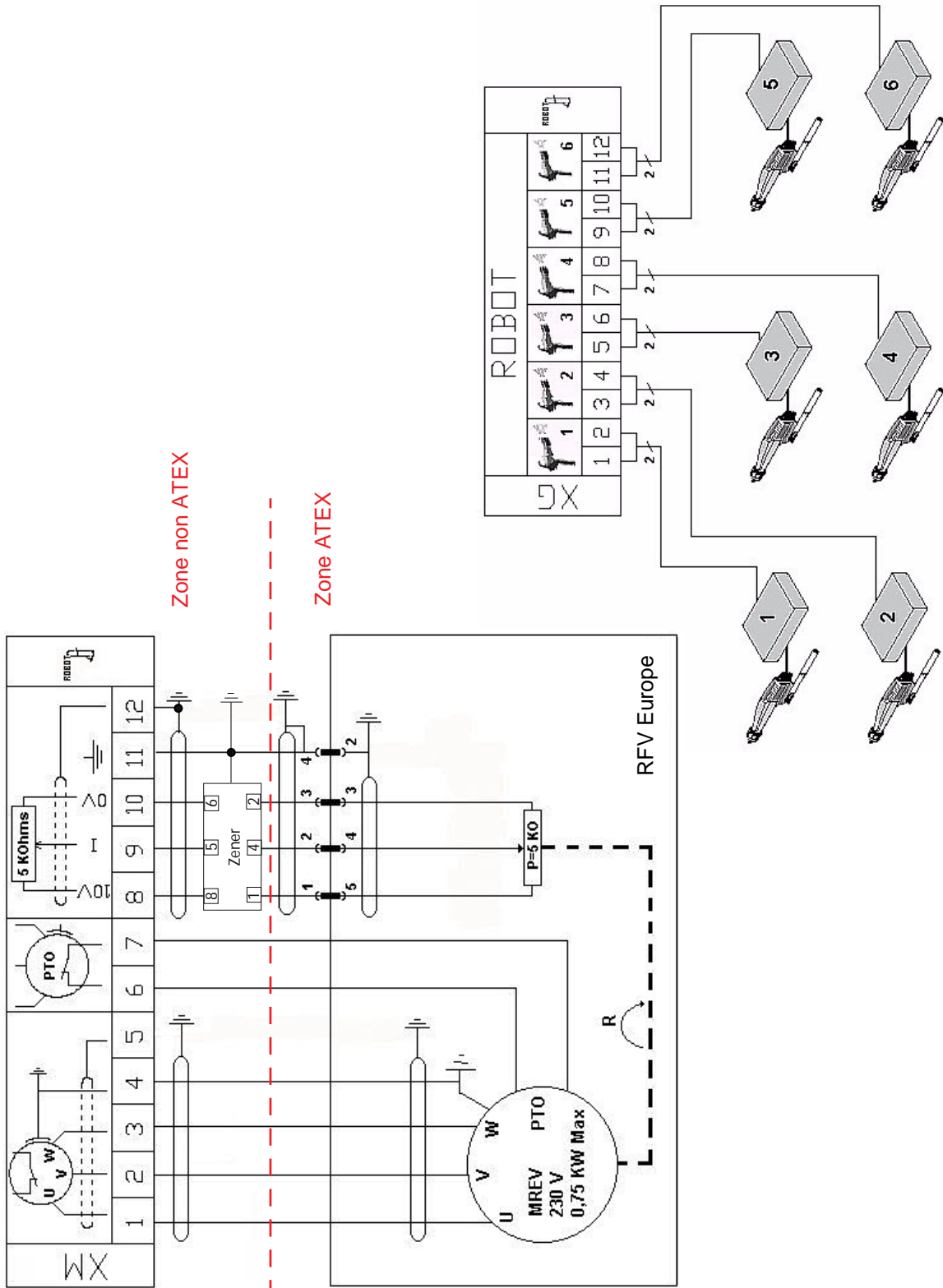

### 3.6.1.1. Installation

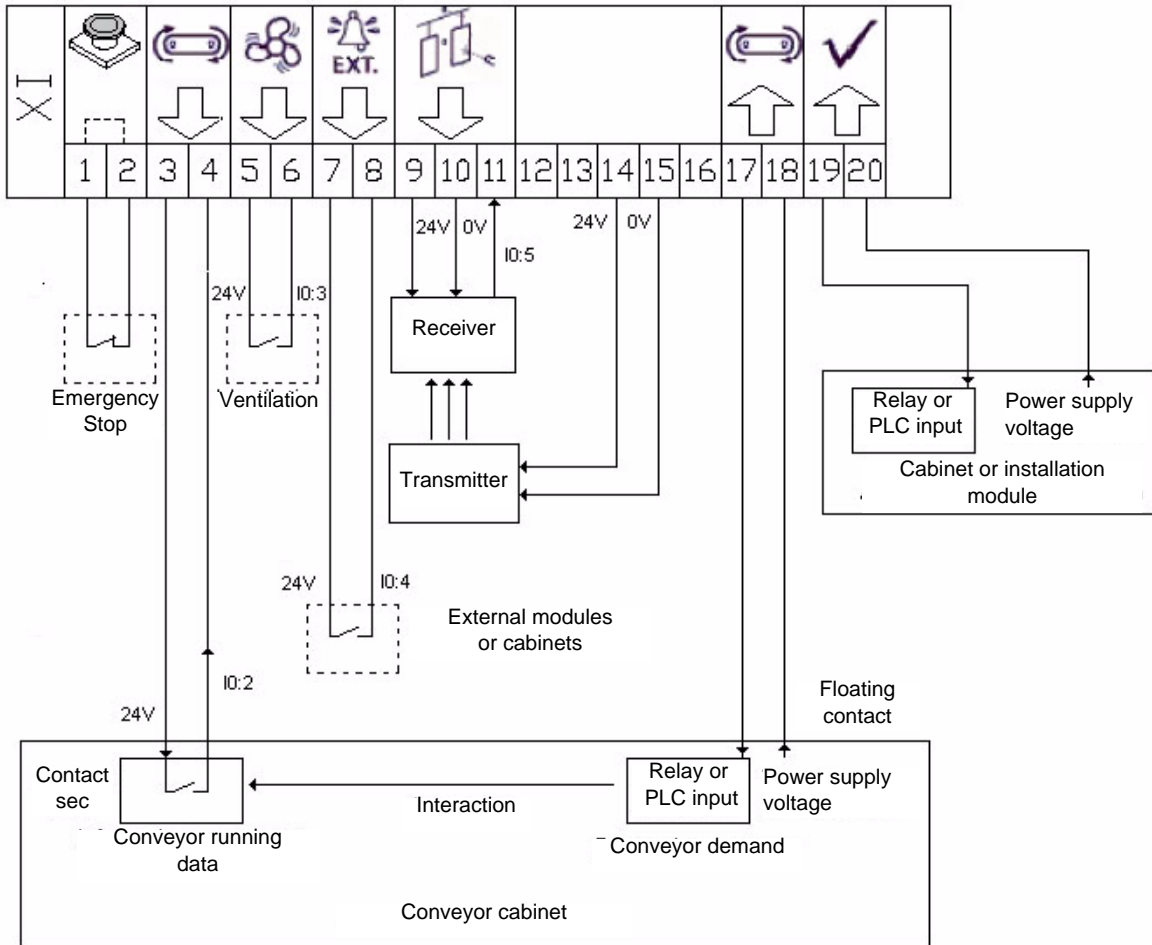

## 4. Connections

### 4.1. Ground Connection



**WARNING : This equipment must be connected to a suitable earth!  
Failure to earth this equipment correctly may give rise to dangerous conditions.**

A green/yellow earth wire of sufficient size must be connected to the grounding stud fitted and labeled as such on the rear panel of the module. The minimum recommended cable size is 2.5 mm<sup>2</sup>.

### 4.2. Connecting the Mains Supply to the Module

#### 4.2.1. Electrical Wiring Diagrams

If a single-phase 230 Volts supply is to be used, connect terminals 2 and 3 together.

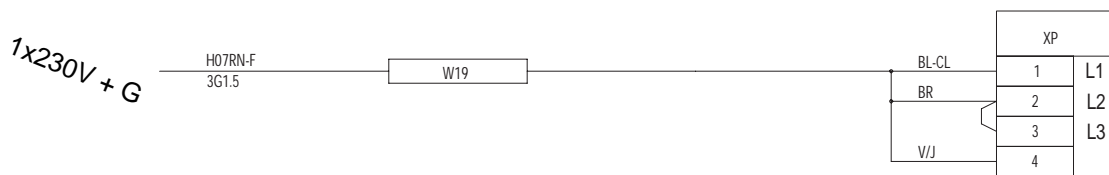

DES02386

If a three-phase 230 Volts supply is to be used, each axis is supplied from a separate phase.

Phase L2 supplies power to robot 1 while phase L3 supplies power to robot 2.

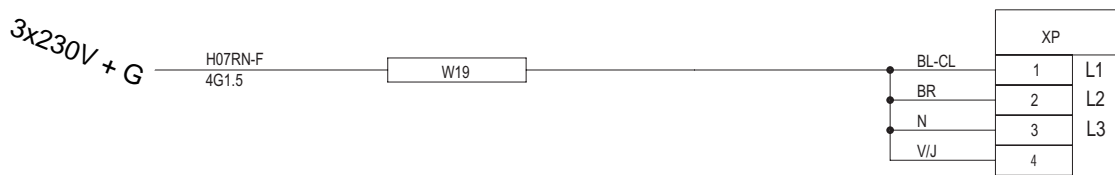

DES02385

The mains voltage must be 230 Volts single-phase or three-phase  $\pm 10\%$ .

The supply frequency must be between 47 and 63 Hertz.

The supply must be rated at a minimum of 16 Amps.

#### For three-phase current 220V:

Sames recommend the use of 4 G 1.5 mm<sup>2</sup> cable (P/N # E2CDKR004).

#### For one-phase current 220V:

The supply cable recommended by Sames (P/N # E4PCAL580),( length 2,5 m) is equipped with a french standard plug.

#### 4.2.2. Control Module

XP terminal strip	Power
Pin 1	L1/N
Pin 2	L2 (Robot 1)
Pin 3	L3 (Robot 2)
Pin 4	Earth (green/yellow)

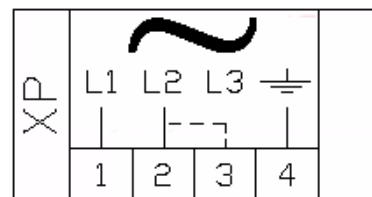

### 4.3. Connections to the RFV 2000 Robots

#### 4.3.1. Electrical Wiring Diagrams

##### Motor with Integrated Thermal Sensor

The data signal from the sensor is connected in series with the speed converter fault signal.

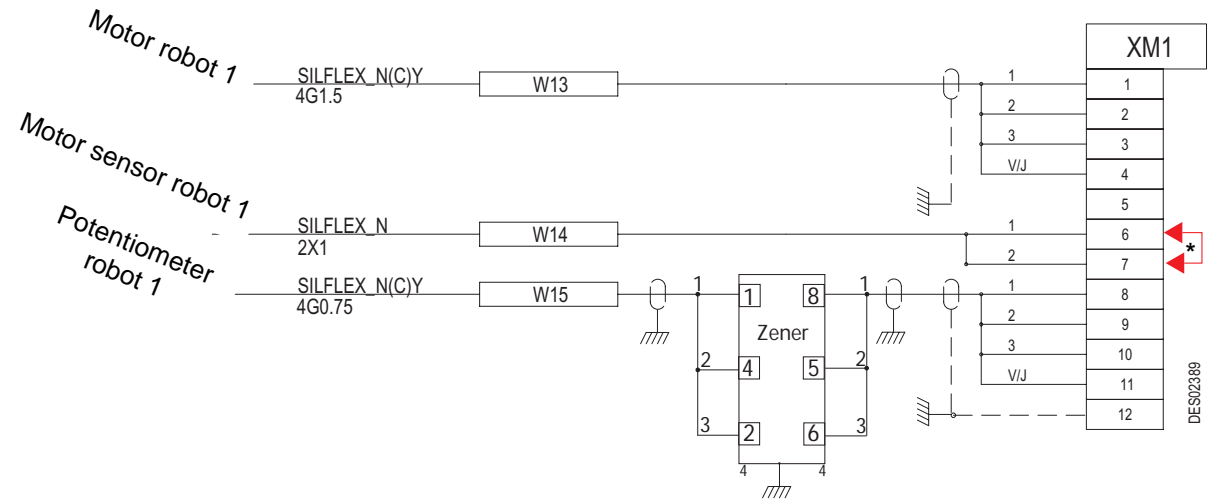

(\*) A bridge between terminals 6 and 7 is always installed. It is necessary to remove it when the information of the thermal sensor is connected.

The following cables are recommended:

Motor	4 G 1.5 mm <sup>2</sup> screened	Ref: 1411222
Thermal sensor	2 x 1 mm <sup>2</sup>	Ref: 1411223
Potentiometer	4 G 0.75 mm <sup>2</sup> screened	Ref: 1409971

#### Location of cables in the shielding resumption collars:

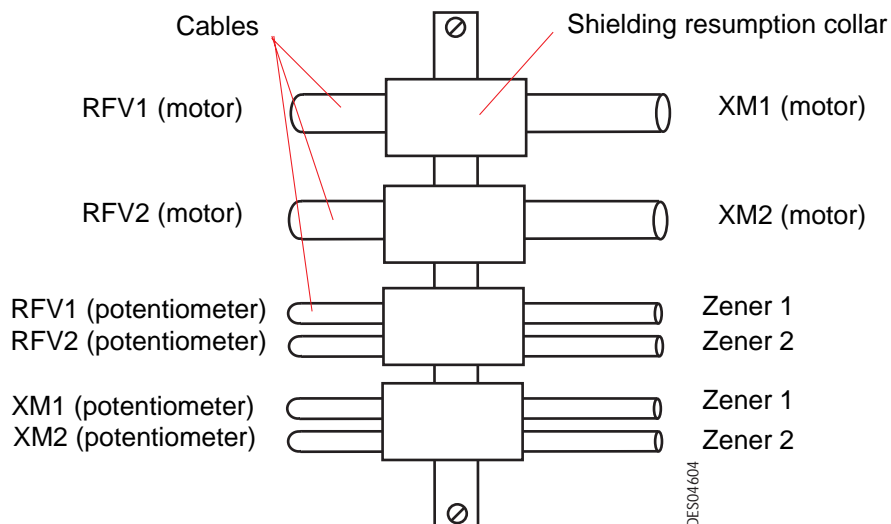

### 4.3.2. Control Module

#### 4.3.2.1. Robot RFV 2000 Europe

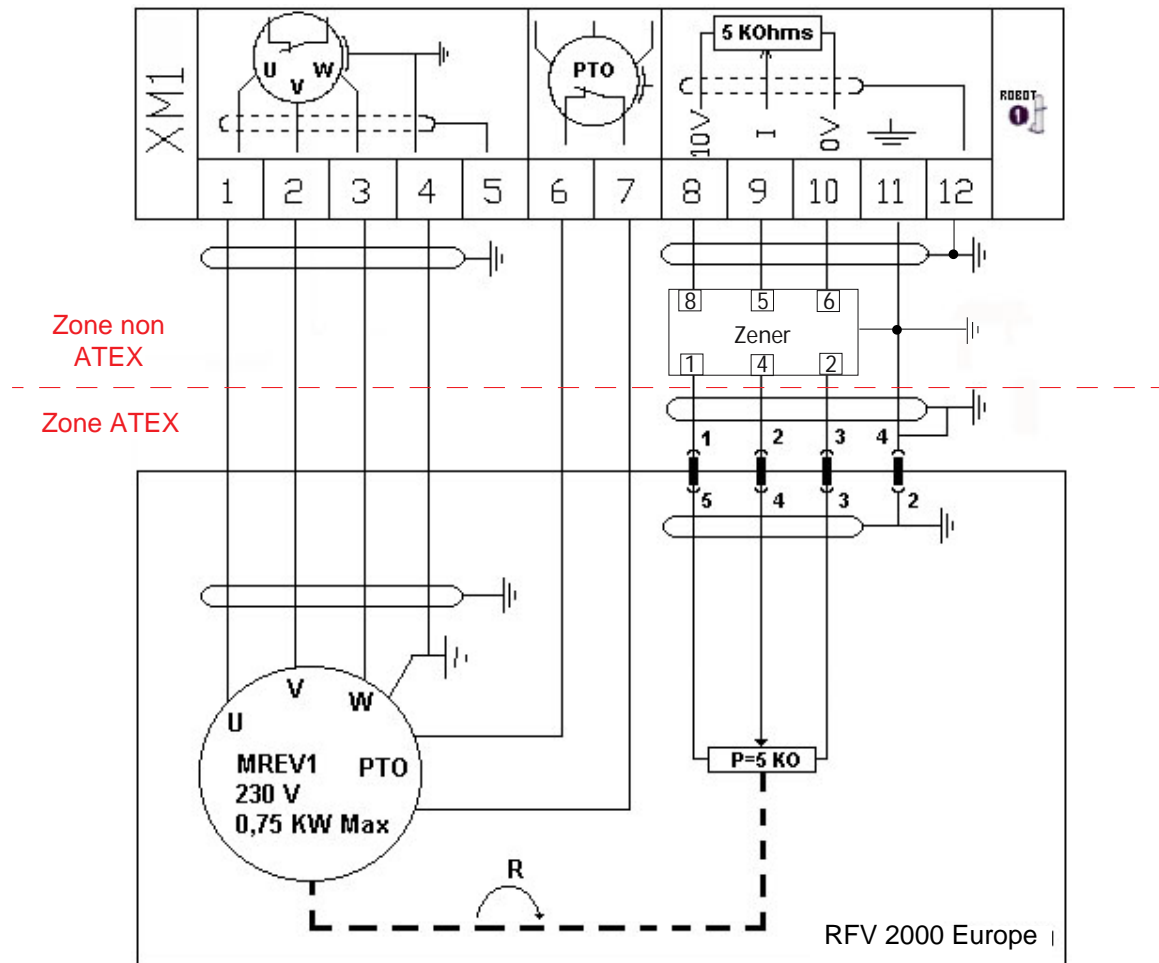

XM terminal strip	Axis of movement
Pin 1	Motor phase U
Pin 2	Motor phase V
Pin 3	Motor phase W
Pin 4	Ground
Pin 5	Motor cable screen
Pin 6	Thermal sensor
Pin 7	Thermal sensor
Pin 8	10 Volt power supply to potentiometer
Pin 9	Potentiometer signal 0-10 Volts
Pin 10	Potentiometer return 0 Volts
Pin 11	Ground
Pin 12	Potentiometer cable screen

The speed converters are factory configured for a 0.75 kW / 230 Volt motor.  
The motor must therefore be 'delta' connected as follows:

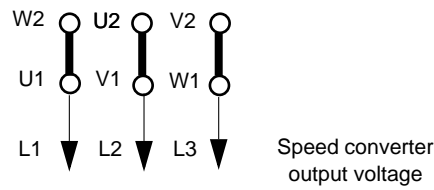

The following motor characteristics are programmed into the speed converter:

Rated motor voltage	230 V
Nominal motor current	3.55 A
Rated motor power	0.75 kW
Rated motor Cos Phi	0.75
Rated motor frequency	50 Hz
Nominal motor speed	1355 rpm
Rise time	0.3 sec
Fall time	0.3 sec
Switching frequency	4 kHz



**WARNING :** the potentiometer must be connected via a zener barrier protection device which is a certified (POT31) electric system.

The zener barrier is installed at the rear of the control module REV600 on a rail provided for this purpose.

Part number of the cable connecting the Zener barrier to the REV 600: 1411224.

Part number of the cable of the potentiometer: 1409971.

4.3.2.2. Robot RFV 2000 US

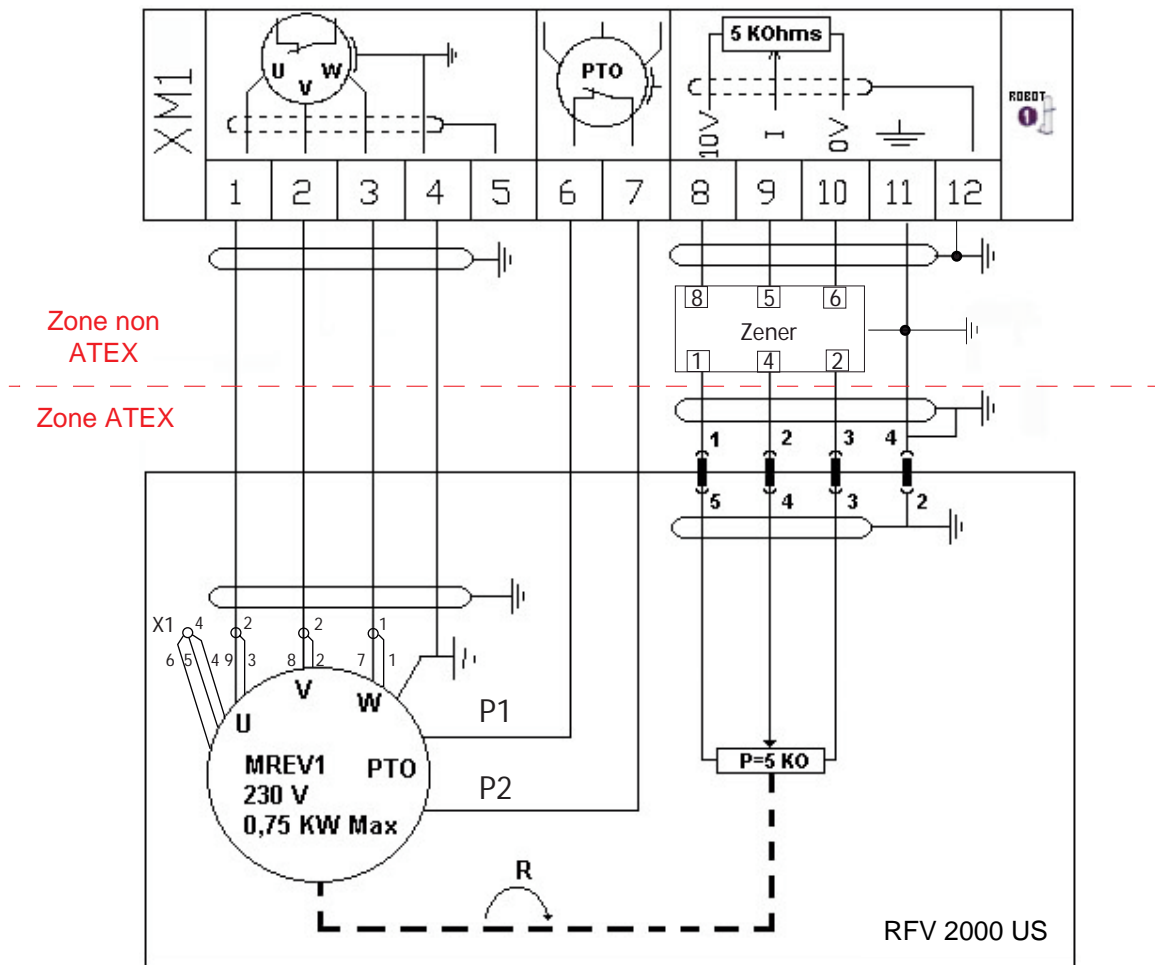



#### 4.4. Connections to the Spray Triggers

##### 4.4.1. Electrical Wiring Diagrams

Each robot is capable of controlling up to six spray triggers.

The term 'spray trigger' refers to a signal used to control a spray module.

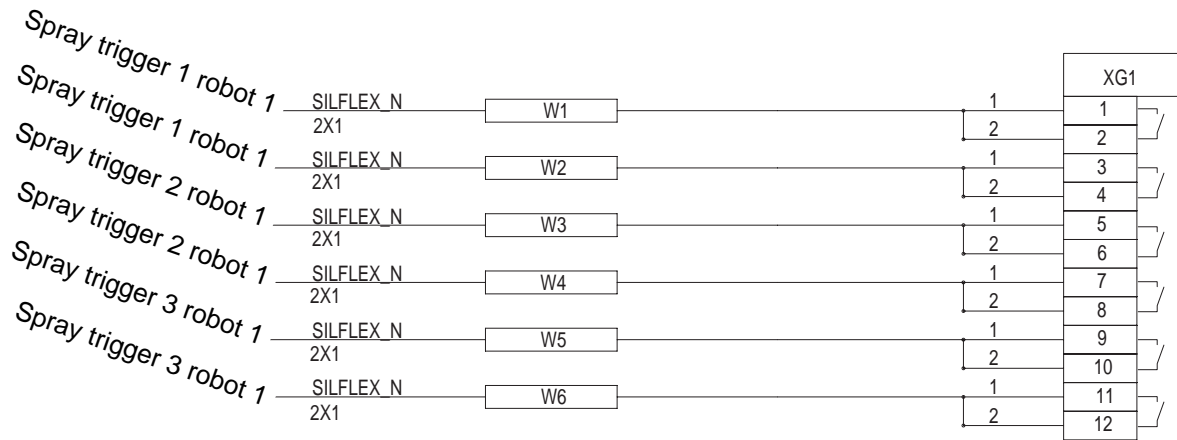

Sames recommends a cable size of 2 x 1 mm<sup>2</sup> Ref: E2LAAB100.

The module uses a normally open floating contact to control the spray module.

The triggers are driven in pairs, corresponding to the planes specified on the operator interface.

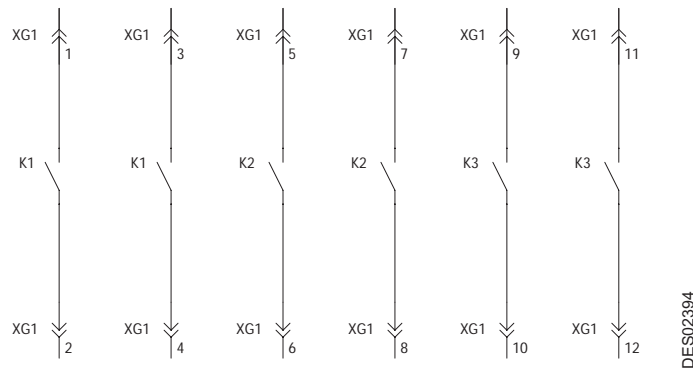

Example of connection of the CRN 457 control module.

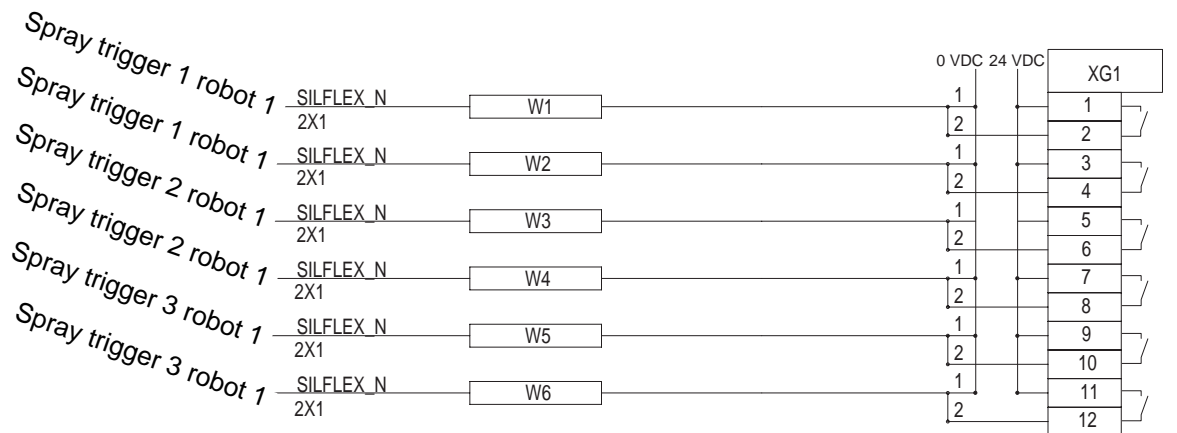

#### 4.4.2. Control Module

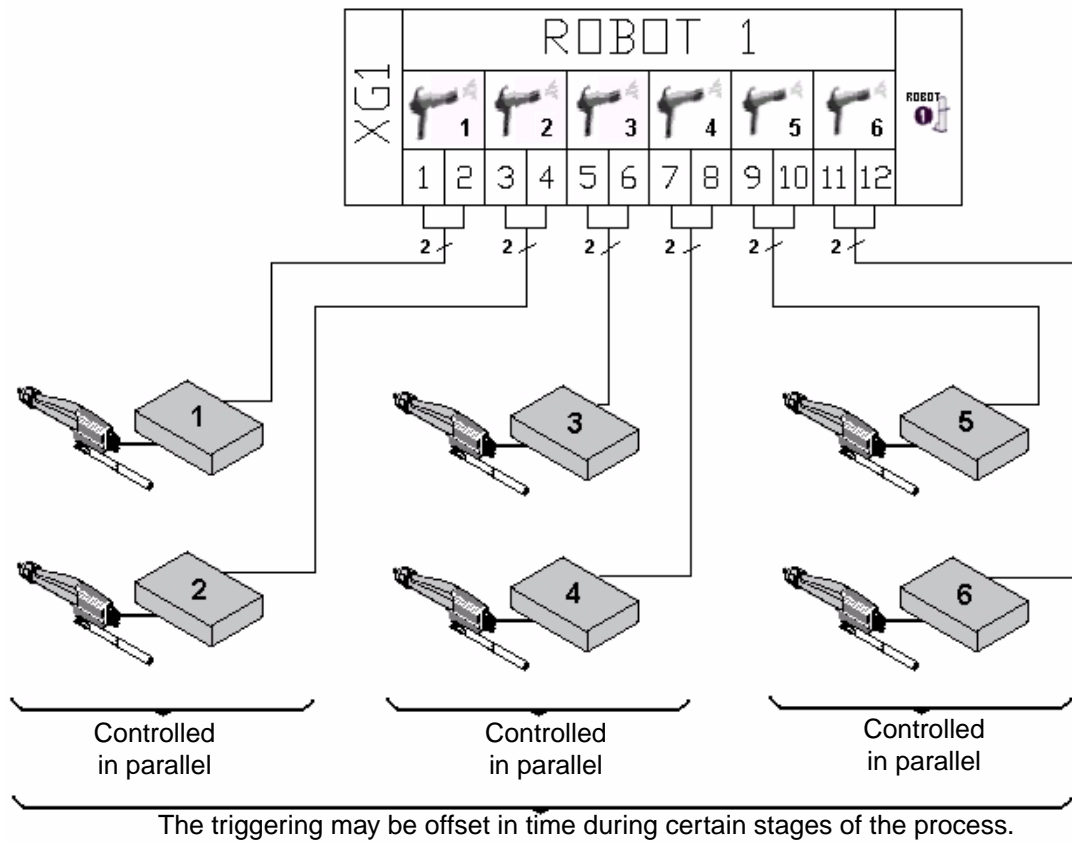

XG terminal strip	Spray control
Pin 1	Trigger 1
Pin 2	Trigger 1
Pin 3	Trigger 2
Pin 4	Trigger 2
Pin 5	Trigger 3
Pin 6	Trigger 3
Pin 7	Trigger 4
Pin 8	Trigger 4
Pin 9	Trigger 5
Pin 10	Trigger 5
Pin 11	Trigger 6
Pin 12	Trigger 6

## 4.5. Interface to the Plant Control System

### 4.5.1. Electrical Wiring Diagrams

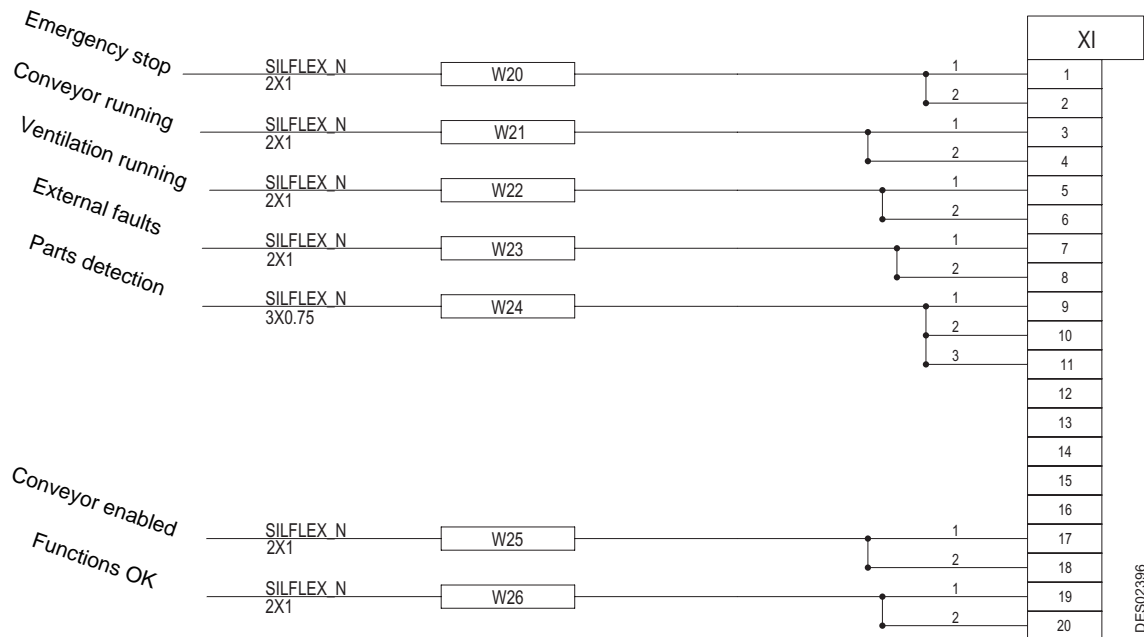

Sames recommends the following cables:

- 2 x 1 mm<sup>2</sup> Ref: E2LAAB100
- 3 x 0.75 mm<sup>2</sup> Ref: E2LDAC075

Each output is a normally open floating contact.

XI terminal strip	Interface inputs and outputs
Pin 1	Emergency stop
Pin 2	Emergency stop
Pin 3	Conveyor running (24 Volts)
Pin 4	Conveyor running input
Pin 5	Ventilation running (24 Volts)
Pin 6	Ventilation running input
Pin 7	External fault (24 Volts)
Pin 8	External fault input
Pin 9	Parts detection (24 Volts)
Pin 10	Parts detection (0 Volts)
Pin 11	Parts detection input
Pin 12	Reserved for future use
Pin 13	Reserved for future use
Pin 14	24 Volts
Pin 15	0 Volt
Pin 16	Reserved for future use
Pin 17	Conveyor enabled
Pin 18	Conveyor enabled output
Pin 19	Module OK output
Pin 20	Module OK output

## 4.5.2. Control Module

### 4.5.2.1. Connection of an Additional Emergency Stop Switch



**WARNING :** If an additional emergency stop switch is not used, pins 1 and 2 on the XI terminal strip must be connected together.

Operating the emergency stop switch breaks the supply to the holding coil in the circuit breaker switch mounted on the front panel of the module.

This then cuts the power to the control module the associated robots.

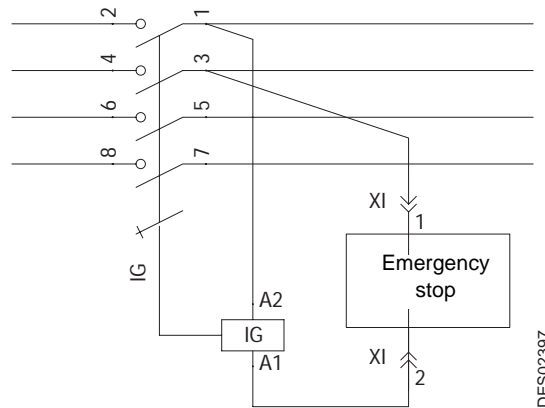

Without emergency stop switch

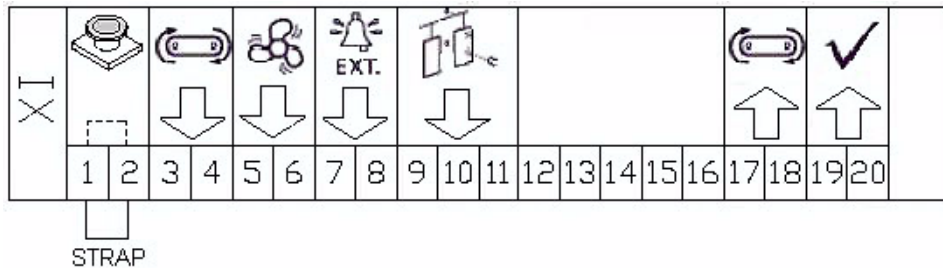

With emergency stop switch

The emergency stop system should provide a normally closed floating contact (i.e. the contact opens when operated).

If an emergency stop signal is received, the REV600 enters 'STOP' mode.

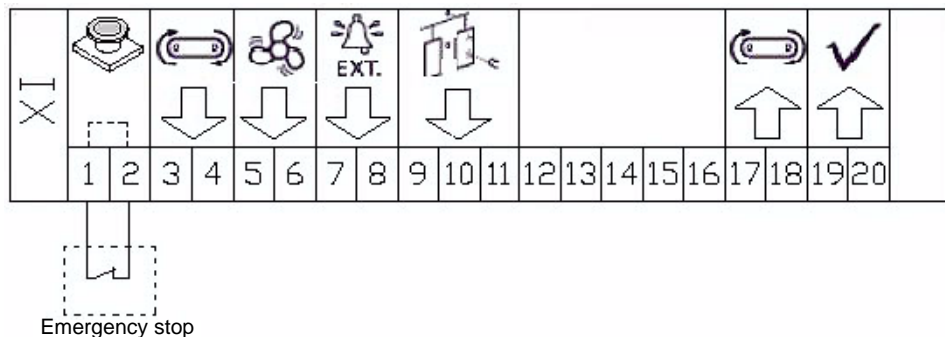

Message = Stop on the display.

#### 4.5.2.2. Conveyor Enabled and Conveyor Running Signals

The module may be interfaced with the plant conveyor control system.

##### Interactive system

In the event of a fault in the REV600 module, the conveyor is stopped by the module until the fault is acknowledged and cleared.

If the conveyor is stopped, the REV600 module goes into 'standby' mode with the display showing the 'no conveyor' fault message until the conveyor restarts automatically.

##### Protocol

When the REV600 is ready, it sends a 'conveyor enable' signal (floating contact between pins 17 and 18) to the conveyor control system.

The conveyor then starts and the conveyor control system returns a 'conveyor running' signal (floating contact between pins 3 and 4) to the REV600.

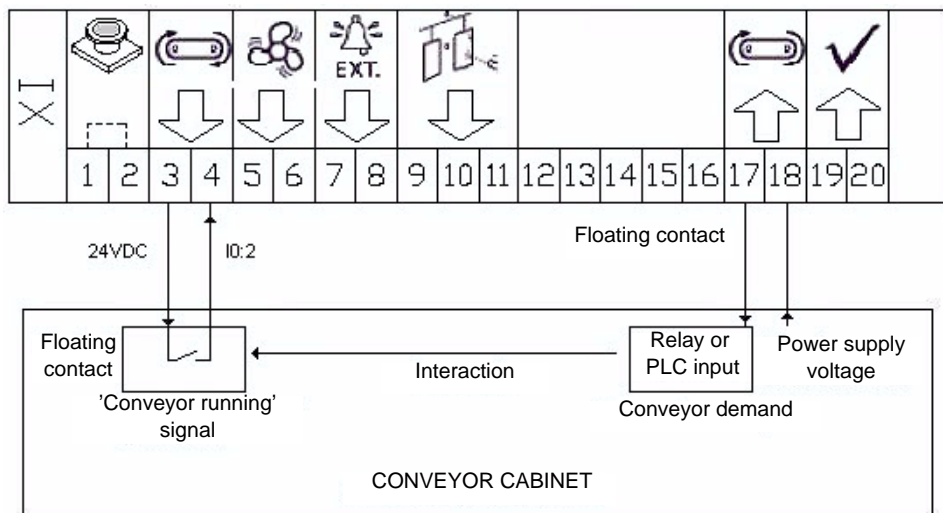

##### Note:

If the REV600 does not receive a 'conveyor running' running signal in automatic mode, it will display a 'no conveyor' error message.

#### 4.5.2.3. Ventilation Running Signal

The module may be interfaced with the plant ventilation control system.

Spraying is only enabled if a 'booth ventilation' signal has been received (floating contact between pins 5 and 6).

If this signal is not present, a 'ventilation fault' message is displayed on the fault view.

The sprayers are shut off and the 'conveyor enabled' signal changes state in order to stop the conveyor.

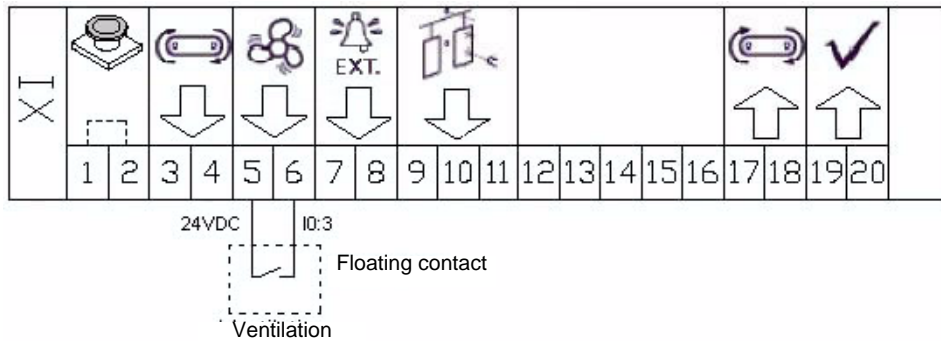

#### Note:

By default, the input is inverted in order to prevent a ventilation fault condition.

#### 4.5.2.4. External Fault Signal

The control module may recognize an external fault signal from another module or cabinet in the plant.

The 'external fault' signal is applied to pins 7 and 8 in the form of a floating contact.

If an external fault is recognized, an 'external fault' message is displayed on the operator interface.

The sprayers are shut off and the 'conveyor enabled' signal changes state in order to stop the conveyor.

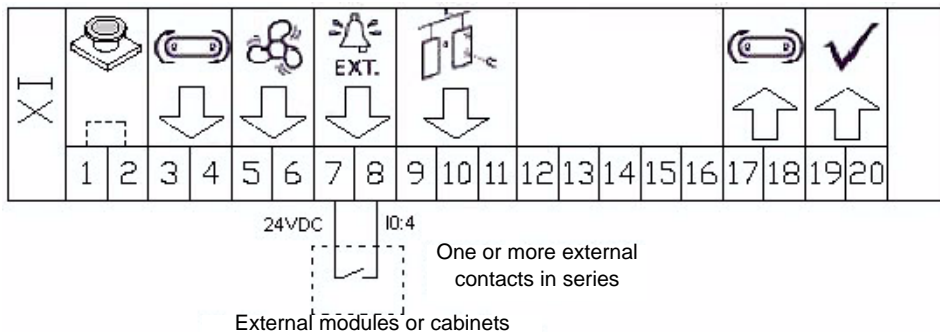

#### Remarks:

Several external fault signals (floating contact) from a number of modules or cabinets in the plant may be connected in series.

By default, the input is configured in order to prevent an external fault condition.

#### 4.5.2.5. Parts Detection

##### Position detector

The part is detected mechanically by the action of the part to be painted or the suspension arm supporting the part.

The position detector sends a 'part detected' signal via a normally open or normally closed floating contact between pins 9 and 11.

The input may be configured to suit the type of contact (normally open or normally closed).

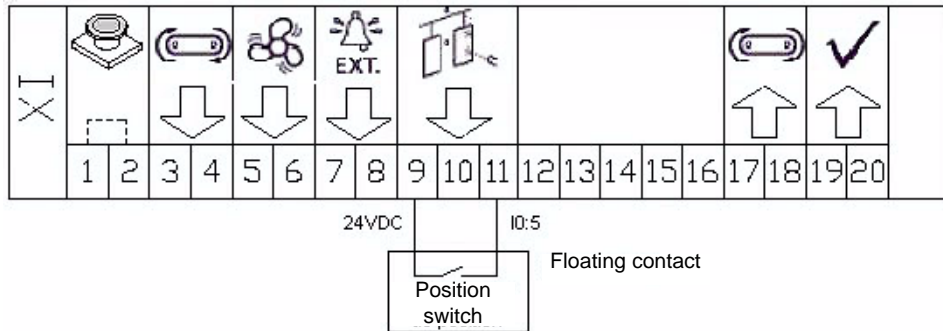

##### Photoelectric detector

The part is detected photoelectrically when the beam is cut by either the part of the suspension arm supporting the part.

The photoelectric cell sends a 'part detected' signal to pin 11.

The input may be configured to suit the type of output from the detector (normally high or normally low).

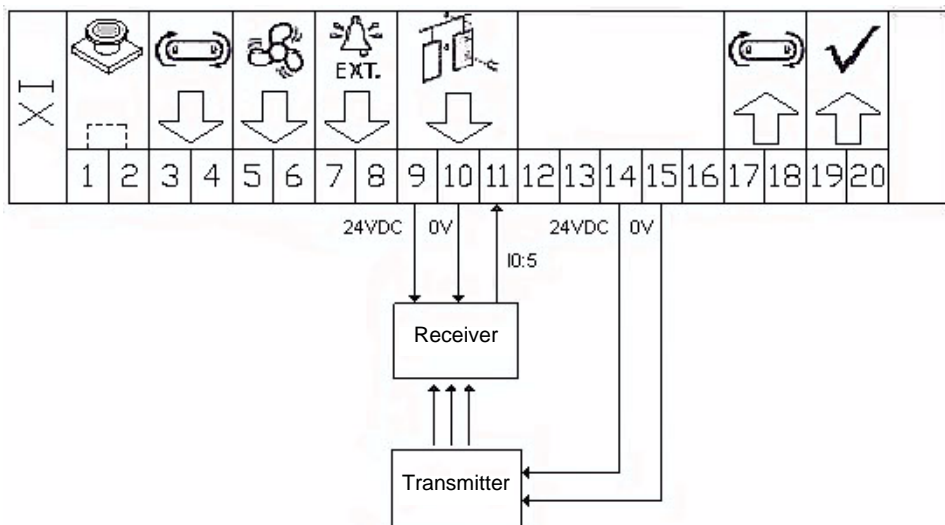

### Control module OK signal

The control module provides a 'control module OK' signal in the form of a floating contact between pins 19 and 20.

This signal may be fed to another module cabinet in the plant via a relay or PLC input.

When the REV 600 is running, this floating contact is normally closed. fermé.

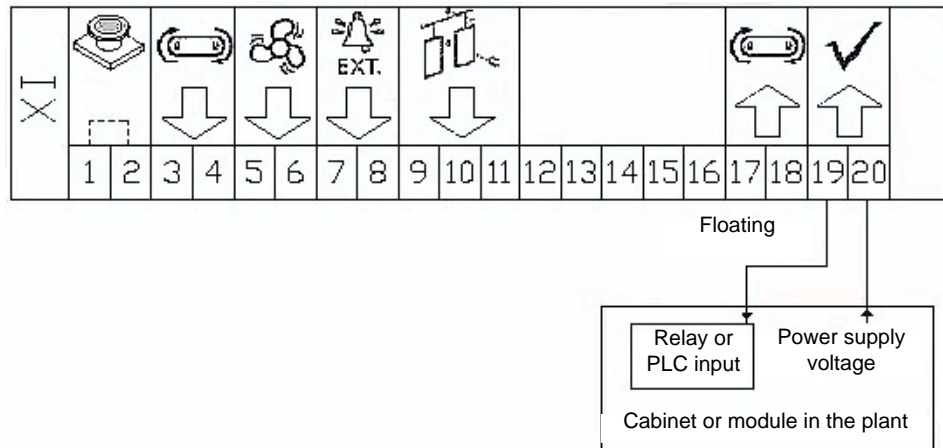

### 5. Spare parts

Part Number	Description	Qty	Sale unit	First Priority	Wear
1523227	REV 600 Control module	-	1	-	-
E6GPSR077AT	Barrier Zener	-	1	X	
E1AAUZ577	Safety battery	-	1		X
E4PTRF589	Connector XP	-	1	-	-
E4PTRF590	Connector XI	-	1	-	-
E4PTRF587	Connector XM1/XM2	-	1	-	-
E4PTRF588	Connector XG1/XG2	-	1	-	-