



From February 1st, 2017 SAMES Technologies SAS becomes SAMES KREMLIN SAS
A partir du 1/02/17, SAMES Technologies SAS devient SAMES KREMLIN SAS



User manual

Nanobell
for
water borne paints



SAS SAMES Technologies. 13 Chemin de Malacher 38243 Meylan Cedex
Tel. 33 (0)4 76 41 60 60 - Fax. 33 (0)4 76 41 60 90 - www.sames.com

All communication or reproduction of this document, in any form whatsoever and all use or communication of its contents are forbidden without express written authorisation from SAMES Technologies.

The descriptions and characteristics mentioned in this document are subject to change without prior notice.

© **SAMES Technologies 2010**



WARNING : SAS Sames Technologies is registered with the Ministry of Labour as a training institution.

Throughout the year, our company offers training courses in the operation and maintenance of your equipment.

A catalogue is available on request. Choose from a wide range of courses to acquire the skills or knowledge that is required to match your production requirements and objectives.

Our training courses can be delivered at your site or in the training centre at our Meylan head office.

Training department:

Tel. 33 (0)4 76 41 60 04

E-mail: formation-client@sames.com

SAS Sames Technologies operating manuals are written in French and translated into English, German, Spanish, Italian and Portuguese.

The French version is deemed the official text and Sames will not be liable for the translations into other languages.

Nanobell
for
water borne paints

1. Health and Safety Instructions - - - - -	5
1.1. Configuration of the certified equipment	5
1.2. Marking on the atomizer	5
1.3. Precautions for Use	6
1.4. Warnings	6
1.4.1. Installation rules	10
1.5. Important Recommendations	11
1.5.1. Compressed Air Quality	11
1.5.2. Product Quality	11
1.5.3. Bearing Safety	11
1.5.4. Locking	12
1.5.5. Shaping Air	12
1.5.6. High Voltage	12
1.5.7. Maximum Speed	12
1.5.8. Vibrations	12
1.5.9. Bell Cup / Turbine Fitting	12
1.5.10. O-ring Seals	13
1.5.11. Ventilation	13
1.5.12. Residual pressure	13
1.5.13. Safety devices	13
1.5.14. Mechanical Collision	13
1.5.15. Ambient Temperature	13
1.5.16. Sound level	13
1.5.17. Specific maintenance provisions	13
1.6. Guarantee	14
2. Description - - - - -	15
2.1. General	15
2.2. Function of the parts	16
3. Technical Characteristics - - - - -	17
3.1. Dimensions, gravity center and tool center point (mm)	17
3.2. Working characteristics	19
3.3. Operating Principle	20
3.3.1. Turbine	20
3.3.2. Turbine Rotation Speed	21
3.3.3. Microphone	21
4. Diagrams - - - - -	22
5. Startup - - - - -	24
5.1. Tools	24
5.2. Installation	26
5.3. Shutdown and Startup Procedures	27
5.3.1. Shutdown Procedure	27
5.3.2. Startup Procedure	27

6. Maintenance	28
6.1. Summary table of maintenance operations	28
6.2. Preventive maintenance	29
6.2.1. Procedure A: Atomizer exterior	29
6.2.2. Procedure B1: Magnetic bell cup	31
6.2.3. Procedure B2: Shaping air assembly	32
6.2.4. Procedure B3: Injector / Injector holder assembly	33
6.3. Corrective maintenance	34
6.3.1. Procedure C1: Body installation / removal	34
6.3.2. Procedure C2: Replacement of turbine	34
6.3.3. Procedure C3: Replacement of solvent pipette	35
6.3.4. Procedure C4: Replacement of microvalves	35
6.3.5. Procedure C5: Replacement of body o-rings	36
6.3.6. Procedure C6: Replacement of fittings and hoses	36
6.3.7. Procedure C7: Replacement of the equipped support	37
6.3.8. Procedure C8: Replacement of the placebo	37
7. Spare parts list	40
7.1. Equipped body	42
7.2. Equipped Support	44
7.3. Injector / injector holder	45
7.4. Placebo UHT 158 without resistor	46
7.4.1. High voltage connection	47
7.5. Robot adapters	48
7.5.1. Adapter for Motoman PX 1450 robot	48
7.5.2. Adapter for ABB IRB 540 robot	48
7.5.3. Adapter for Kawasaki KF 121 robot	48
7.5.4. Adapter for Staubli TX 60 robot	49

1. Health and Safety Instructions

This manual contains links to the following user manuals:

- [see RT Nr 7071](#) for the user manual of bell cups and shaping air assemblies, Hi-Te Technology
- [see RT Nr 6350](#) for the user manual of the turbine type "BTM".
- [see RT Nr 6021](#) for the user manual of the microvalve.
- [see RT Nr 7073](#) for the user manual of the high voltage unit UHT 287 EEx e.
- [see RT Nr 6190](#) for the microphone.
- [see RT Nr 6364](#) for the user manual of the electric systems,
- [see RT Nr 6213](#) for the user manual of the control module GNM 200.

1.1. Configuration of the certified equipment

The whole of these user manuals defines the configuration of the certified equipment.

1.2. Marking on the atomizer

SAMES Meylan France

CE 0080

Nanobell

P/N : *

ISSeP06ATEX032X**



II 2 G

EEx > 350mJ

(Serial number)

Atomizer Nanobell - P/N 910008556 Support - P/N 910007374 Equipped body - P/N 910007461 S12 Turbine - P/N 1525802	P/N Nanobell (*)	UHT 287 EEx e - P/N 910008371	GNM 200A P/N 1517071
X	910008556	X	X

** The sign "X" signifies that respecting the safety distance (between the parts of the sprayer that are under high voltage and the grounded parts) mentioned in this user's manual, ensures a safe use of the equipment.

1.3. Precautions for Use

This document contains information that all operators should be aware of and understand before using the Nanobell. This information highlights situations that could result in serious damage and indicates the precautions that should be taken to avoid them.



WARNING : Before any use of the Nanobell equipment, check that all operators:

- have previously be trained by the compagny Sames Technologies, or by their distributors registered by them for this purpose.
- have read and understood the user manual and all rules for installation and operation, as laid out below.

It is the responsibility of the operators' workshop manager to ensure these two points and it is also his responsibility to make sure that all operators have read and understood the user manuals for any peripheral electrical equipment present in the spraying area.

1.4. Warnings



WARNING : Safety may be jeopardized if this equipment is not operated, disassembled and reassembled in compliance with the instructions given in this manual and in any European Standard or national safety regulations in force.



WARNING : Equipment performance is only guaranteed if original spare parts distributed by SAMES Technologies are used.



WARNING :

This equipment has to be used only within areas designed for spraying with respect to EN 50176, EN 50177, EN 50223, or with similar ventilation conditions. The equipment has to be used only within ventilated in order to reduce risks for the health of the operators, fire or explosion. The efficiency of the extraction ventilation system has to be daily checked.

Within explosive atmospheres produced by the spraying process, only appropriate explosion-proof electrical equipment has to be used.

Before carrying out any cleaning or general work on atomizers in the spraying area, the high voltage generator must be switched off and the atomizer HV circuit discharged to the ground.

The pressurised coating product or the pressurised air must not be directed towards people or animals.

Appropriate measures have to be taken to avoid, during periods when the equipment is not used and/or when the equipment is broken, the presence of potential energy (liquid or air pressure or electric) inside the equipment.

Using individual protection equipment will limit the risks of contact and/or inhalation of toxic product, gas, vapours, fog or dusts that can be produced while using the equipment. The user has to follow the coating product manufacturer's recommendations.

Electrostatic spraying equipment must be serviced regularly in accordance with the information and instructions given by SAMES Technologies.

It is strictly prohibited to stick adhesive tape on the atomizer body.

Cleaning operations must be carried out either in authorised areas equipped with a mechanical ventilation system, or using cleaning liquids with a flash point at least 5 °C higher than room temperature.

Only metal containers can be used for cleaning liquids and they must have a reliable ground connection

The insulated supply of waterborne paint must be placed in a closed enclosure (by respecting an insulating distance sufficient). Access must be controlled to the high voltage supply and equipped with a short-circuiter, which must be placed outside the dangerous areas. This device must be able to discharge to the ground all the parts at high voltage before being accessible.

Inside the booth it is forbidden to use a naked flame, glowing object or a device likely to produce sparks. It is also forbidden to store inflammable products, or vessels that have contained them, close to the booth.

The surrounding area must be kept clear and clean.



WARNING : The use of very high voltage increases the risk of sparks. SAMES Technologies atomizers and high-voltage electrostatic generators are designed to minimize this risk. Although the HV electrode is the only accessible part, a safety distance of X mm (refer to: Board) has to be maintained between the parts of the sprayer that are under high voltage and all the parts that are grounded.

Nanobell with UHT 287 EEx e high voltage unit:

Authorised spraying distance	
Tension (kV)	Distance (mm)
0	100
50	
60	
70	150

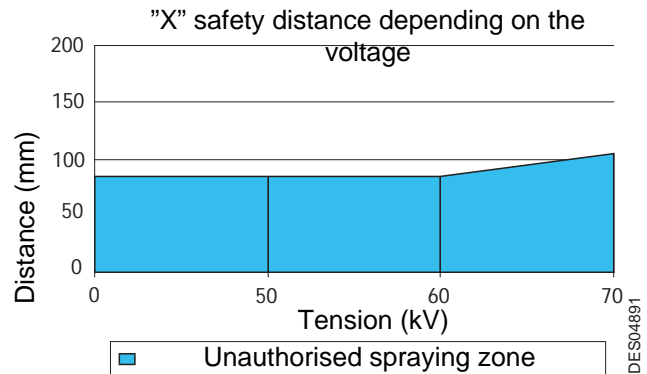

Any installation by isolated system (waterborne) must be equipped with a short-circuiter which acts in less than two seconds ($E < 350 \text{ Mj}$ in less than two seconds).

The use of a UHT 287 imposes a connection to a control module GNM 200 whose version of program must be higher or equal to V5.63.

In addition, a careful check must be made to ensure that any conducting or semi-conducting part closer than 2.5 m to the atomizer is correctly grounded.

If it is not, electrical charges capable of causing sparks could build up on it. Operating personnel must wear anti-static shoes and gloves to avoid this risk.

All metal parts of the booth and parts to be painted must be correctly grounded. Ground resistance must be less than or equal to $1 \text{ M}\Omega$ (minimum measurement voltage 500 V). This must be checked regularly.

Grounding is mandatory for all the conductive envelops of the electrical equipments and for all the conductive components within explosive atmospheres by conductive connection with the ground terminal.

Finally, for the same reasons, the spraying area must have an anti-static floor, such as concrete, metal duckboard, etc.

It is essential to provide sufficient ventilation in the spraying booths to avoid the build up of inflammable vapors.

The effectiveness of the overcurrent protection (di/dt) must be checked every day. This check must be carried out in an area with **no explosive atmosphere** by placing a ground device near the electrode of the atomizer when the atomizer is switched on (the operator must be connected to ground): the control module must switch to the fault state.

Additional equipment has to be placed outside the dangerous area and its starting device has to be servo-controlled to the running mode of the booth aspiration fan. The correct working of the servo-control has to be checked once a week.

A warning board has to be placed in full view close to the spraying area.

An excessive turbine speed can engender major damages on the turbine as well as a loss of connection bell/turbine; this represents a risk for persons and equipment. The maximum speed indicated in this user manual must not be exceeded ([see § 3.2 page 19](#)).

1.4.1. Installation rules

Nanobell using water borne paints.

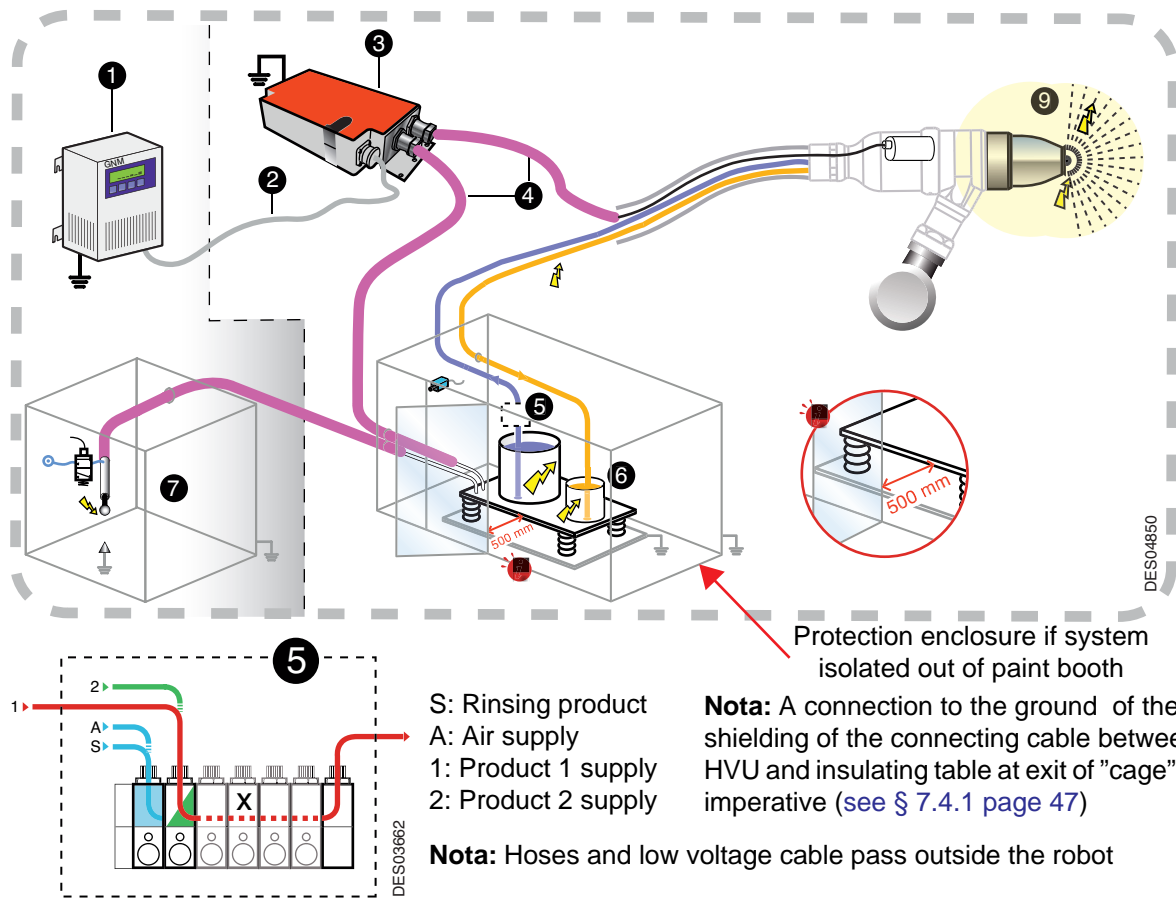

WARNING : All the conductive components must be connected to the high voltage potential (metallic fittings of Moduclean, gear pump, etc...).

Wareborne paints non flammable and not easily flammable	
1	Control module GNM 200 (out of the ATEX area)
2	Low voltage connection
3	High voltage unit UHT 287 EEx e
4	High voltage cable connecting UHT 287 / Insulating table and UHT 287 / Nanobell
5	Supplies of paints and rinsing products insulated to the ground potential
6	Dump return line insulated to the ground potential
7	Short circuiter (out of the ATEX area)
8	-
9	Safety distance (area around the the atomizer head from the parts with high voltage outer cover, bellcup etc...)



WARNING : It is strictly prohibited to install an unspecified system not complying with the rules described above.

1.5. Important Recommendations

1.5.1. Compressed Air Quality

The air must be filtered to a level that will guarantee a long life time and prevent any pollution during painting.

The filter must be installed as close as possible to the facility. The filter cartridges must be changed regularly to ensure that the air is clean.

PTFE tape or glue should not be used between the filter and the bearing as glue residue or pieces of PTFE may block the small holes of the air bearing and cause turbine failure.

The inside of hoses supplying air to the atomizer and the ports of the quick-disconnect plate must be clean and free of any traces of paint, solvent or other foreign matter.

The guarantee does not cover faults caused by unclean, unfiltered bearing air resulting from disregard of the previous recommendations.



WARNING : If the air is not correctly filtered, the bearing may become fouled resulting in a turbine operating fault. The filtering system used must prevent particles greater than 5 µm in diameter from reaching the bearing.



WARNING : The guarantee does not cover damage caused by foreign matter such as paint, solvent or other substances entering the air circuits of the Nanobell.

1.5.2. Product Quality

The paint must be filtered to prevent any damage to the atomizer.

The maximum permissible particle size in the atomizer is 200 µm.

1.5.3. Bearing Safety

The compressed air connection to the air bearing must be made directly to the supply circuit without the use of an isolating valve.

During operation, the air bearing must be continuously under pressure, otherwise considerable damage may be caused. A sudden cut in the air supply could destroy the air bearing of the turbine. Wait until the turbine has stopped completely before cutting off the bearing air.

Procedure for cutting off air to the air bearing:

- Switch off the turbine rotation air supply
- Wait until the turbine has stopped completely (at least 150 s).
- Switch off the bearing air supply.

Running the turbine with bearing air pressure of less than 6 bar at the atomizer inlet can damage the bearing. The standard bearing air pressure is 6 bar at the air control cabinet.

All these pressure values are measured at the atomizer inlet. If the bearing pressure drops below 6 bar at the turbine or atomizer inlet, cut off the air supply to the turbine.

In addition, a 25-liter air reserve should be available so that the turbine brakes gradually if the main air supply is cut off suddenly.



WARNING : The guarantee does not cover faults that occur if the turbine is operated with insufficient bearing air pressure.

1.5.4. Locking

Do not atomize the product if the bellcup is not turning at a speed of at least 15000 rpm. At lower speeds, paint or solvent may enter the turbine, bearing and control circuits. Opening the head valve, injector rinsing valve and bellcup exterior rinsing valve must be prohibited when the bellcup is not turning. Only qualified personnel are authorized to by-pass this locking system for flow rate checks.



WARNING : If the turbine is not already operating, wait, after starting it up, until the bellcup reaches at least 15000 rpm before opening the head valve. The recommended minimum waiting time is 2 seconds.

1.5.5. Shaping Air

Do not atomize the product until the shaping air rate is at least 80 NI/mn (i.e. 0.3 bar at the atomizer inlet). If it is less, there may be a feedback of atomized product which fouls the outer cover and the inside surface of the air shroud resulting in application faults.

1.5.6. High Voltage

Disable the high voltage if the Nanobell is not operated for a prolonged period (conveyor shutdown, no objects to be painted, slack periods, etc.) to prevent ionization of the air.



WARNING : Rinsing cycles (bellcup exterior and injector) must be carried, beforehand switching off the high voltage power supply.

1.5.7. Maximum Speed

Excessive turbine speed can result in serious damage to the turbine and loss of connection between the bell cup and turbine, presenting a risk to persons and equipment. The speed must not exceed 45,000 rpm.



WARNING : The guarantee does not cover damage resulting from a rotation speed greater than 45,000 tr/min.

1.5.8. Vibrations

If the atomizer vibrates more than usual, the cause is generally unbalanced rotating parts. There may be dry paint deposits on the bell cup or rotor. If any of these situations arise, it is essential to correct them. Excessive unbalance may damage the turbine resulting in failure to operate or even loss of the bell cup / turbine connection, presenting a risk for persons and equipment.



WARNING : The guarantee does not cover damage caused by unbalance of the rotating parts.

1.5.9. Bell Cup / Turbine Fitting

The bell cup must be correctly fitted on the turbine, a snap must be heard; the two cylinders must fit on top of each other without any foreign matter between them. If fitting is incorrect, the connection may be lost and the bell cup thrown out still spinning, presenting a risk for persons and equipment.

1.5.10. O-ring Seals

Use the seals recommended in this manual. For solvent-based products, seals in contact with the product must be chemically inert seals resistant to swelling or chemical attack. The Nanobell is only guaranteed to operate correctly if it is used with seals whose size and material conform to this manual.

1.5.11. Ventilation

Do not begin applying paint with the Nanobell before starting up the ventilation system in the spraying booth. If the ventilation is cut, toxic substances such as organic solvents or ozone may remain in the spraying booth, resulting in a risk of fire, poisoning or irritation.

1.5.12. Residual pressure

Before all maintenance or repair operations, remove paint and solvent from the atomizer, switch off the high voltage power supply and cut the paint, solvent and air supplies, then release residual pressure in each supply system. Residual pressure may lead to component damage and expose personnel to serious injuries. Paint or solvent dispersion may also lead to poisoning or irritation.

1.5.13. Safety devices

During installation of the Nanobell, it is important to set up safety devices enabling high voltage power, paint, solvent and air supplies to be cut immediately if there is a problem.

- Detection of control system faults
- Detection of high voltage surges linked with the SAMES high voltage module.
- Detection of air pressure drops.
- Detection of ventilation failure.
- Detection of fire
- Detection of human presence.
- Detection of turbine rotation speed faults.

Failure to install safety devices could result in a risk of fire, expose the personnel to serious injury and damage the equipment.

1.5.14. Mechanical Collision

The guarantee does not cover damage resulting from the operating environment (for example collision with the robot).

1.5.15. Ambient Temperature

The sprayer is designed to work normally under room temperature between 0°C and + 40°C.

In order to optimise application quality, it is advised to work under room temperature between + 15°C and + 28°C.

The storage temperature will never exceed +60°C.

1.5.16. Sound level

The acoustic pressure level, continuous, equivalent, weighted, equals to 59.7 dBA.

Conditions of measurement:

The equipment has been run at its maximum values, the measures have been made from the operator desk of the paint test booth "API" (closed booth with glass walls) of the Research & Development laboratory at Sames Meylan France.

Method of measurement:

The acoustic pressure level, continuous, equivalent, weighted (59.7 dBA) is given in LEQ value, measured for observation periods of at least 30 seconds.

1.5.17. Specific maintenance provisions

The access of the booth, near the atomizer in operation, will have to be proscribed and controlled by safety devices ([see § 1.5.13 page 13](#)) which will have to stop the equipment in case of intrusion of people in the area.

Nevertheless, for maintenance operation, these safety devices will have to be arranged in order to allow certain operations and checks (only for persons trained and entitled by Sames Technologies).

The turbine rotation with a bellcup, in all the cases, will be prohibited with personnel in the area.

1.6. Guarantee

Under the guarantee, which applies only to the buyer, **SAMES Technologies** agrees to repair operating faults resulting from a design fault, materials or manufacture, under the conditions set out below.

The guarantee claim must define, in writing, the exact nature of the fault concerned.

The **SAMES Technologies** guarantee only covers equipment that has been serviced and cleaned according to standard procedures and our own instructions, that has been fitted with parts approved by **SAMES** or that has not been modified by the customer.

More precisely, the guarantee does not cover damage resulting from:

- the customer's negligence or inattentiveness,
- incorrect use,
- failure to follow the procedure
- use of a control system not designed by **SAMES Technologies** or a **SAMES Technologies** control system modified by a third party without written permission from an authorized **SAMES Technologies** technical agent,
- accidents such as: collision with external objects, or similar events,
- flooding, earthquake, fire or similar events,
- inadequately filtered bearing air (solid particles more than 5 µm in diameter),
- inadequately filtered paint and solvent,
- use of seals not complying with **SAMES Technologies** recommendations,
- starting up turbine rotation without minimum bearing air pressure (6 bar),
- exceeding the maximum speed of 45000 rpm under load,
- starting up rotating parts that are unbalanced (dry paint on bellcup, rotor or damaged bellcups),
- pollution of air circuits by fluids or substances other than air.

SAMES Technologies atomizer **Nanobell** is covered by a one-year guarantee for use in two 8-hour shifts under normal operating conditions.

By concession, the guarantee is extended to 10000 hours on the air turbine of the **Nanobell**. The guarantee does not apply to wearing parts such as atomizing bellcups, diaphragms, clips, seals, etc.

The guarantee will take effect from the date of the first startup or of the provisional acceptance report.

Under no circumstances, either in the context of this guarantee or in other contexts, will **SAMES Technologies** be held responsible for physical injury or intangible damage, damage to brand image and loss of production resulting directly from its products.

2. Description

2.1. General

Atomizer **Nanobell** is a robotic rotary atomizer, dedicated according to versions, to the application of solvented or waterborne paints, mono paintings or multi-components. It is used in environments of automatic electrostatic atomization, its design makes of this atomizer equipment simple, easy to maintain. Light and compact, it can equip with the small size robots.

Equipped with a magnetic air bearing turbine, the atomizer **Nanobell** can atomize with a maximum rotation speed of 45 000 rpm.

Atomizer Nanobell allows to improve the quality of production while making significant savings of paint.

Main components:

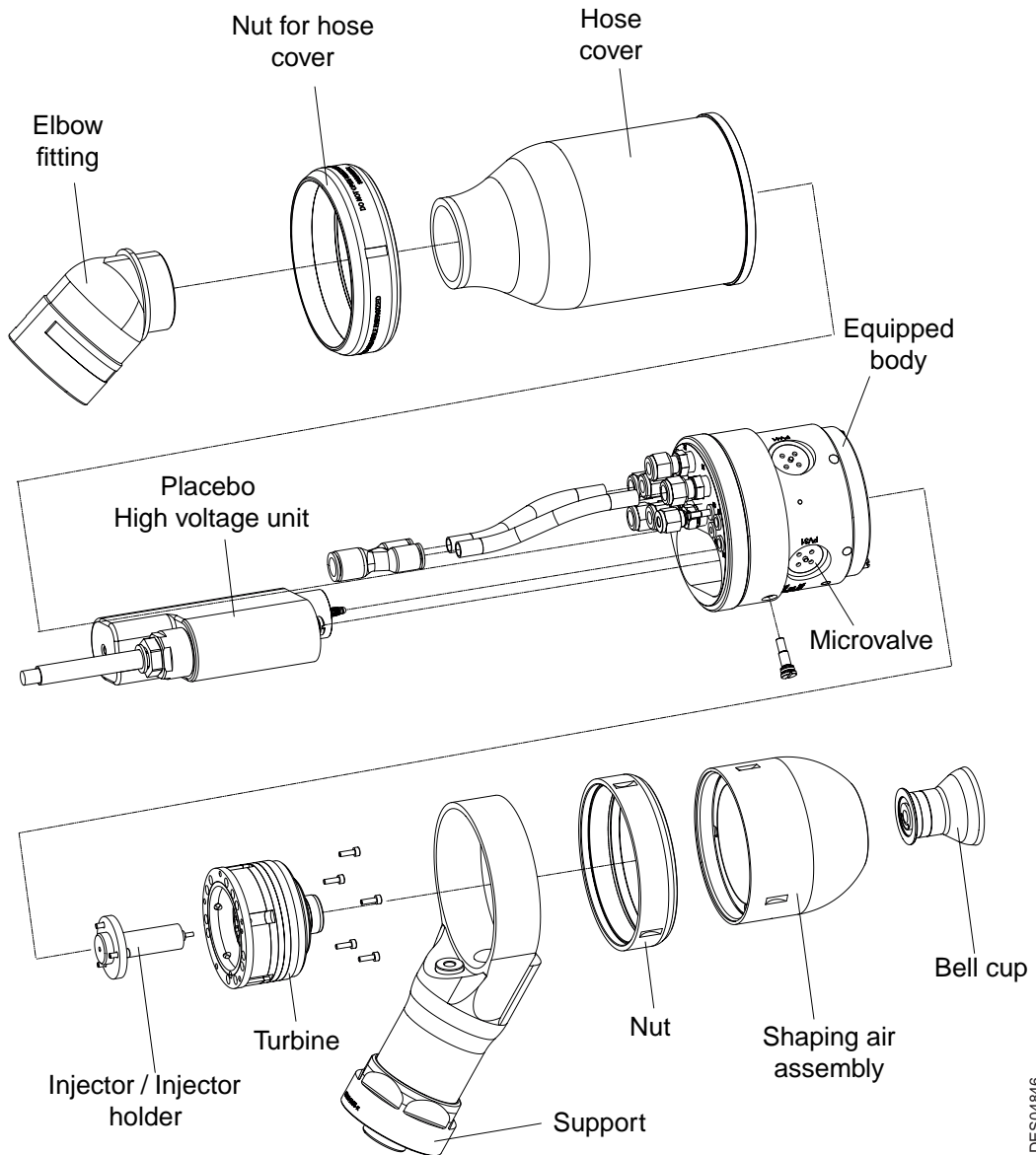

DES04846

2.2. Function of the parts

Parts	Function
Bell cup	The bell cup atomizes all types of paint. It is selected according to the type of product used.
Turbine	The rotation of the bell cup is produced by a pneumatic motor. Atomization results from the centrifugal forces generated by rotation of the bell cup. The size of sprayed paint particles decreases as the speed of the turbine motor increases.
Body	The body houses all the fluid circuits, product, air and solvent microvalves and the injector / injector holder assembly.
Shaping air assembly (outer cover / shaping air shroud)	These parts control the size and pattern diameter and transfer the particles to the parts to be painted. They protect internal components and allow easy cleaning.
Injector holder Injector	Keeps the injector in the center of the bell cup. It also has an opening to supply the microphone air. The injector is used to regulate the paint flow rate into the bell cup. The inner diameter of the restrictor is selected according to the viscosity of the paint and the required paint thickness
Micro-valve	Air-controlled, 2-way, normally closed valves used for various operations: paint supply, paint rinse, bell cup exterior rinse, injector rinse
High voltage unit placebo	Allows to supply the atomizer with high voltage from the high voltage unit.

3. Technical Characteristics

3.1. Dimensions, gravity center and tool center point (mm)

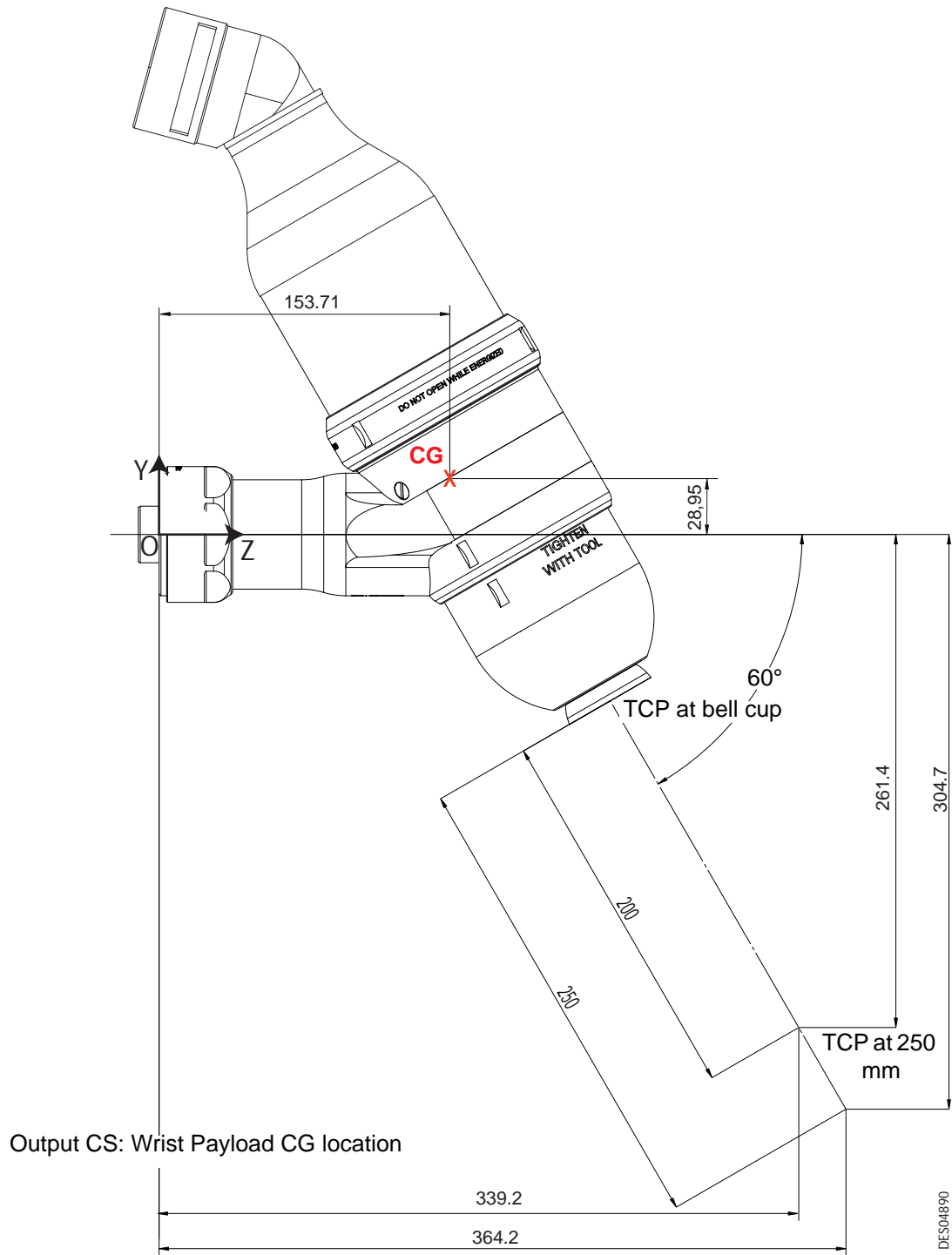

Note:

TCP : Tool Center Point

Weight: 3.4 kg

Gravity center (CG) in millimeters

X = -0.45

Y = 28.95

Z = 153.71

Main inertia axis and moments (kg x mm²), measured to the gravity center:

Ix = (-0.01 , 0.82 , -0.58)	Px = 72264.25
Iy = (-0.01 , 0.58 , 0.82)	Py = 271047.21
Iz = (1.00 , 0.01 , 0,00)	Pz = 300149.02

Inertia moments (kg x mm²), measured to the output C.S:

Ixx = 111370.16	Ixy = -153,03	Ixz = -189.55
Iyx = -153.03	Iyy = 94844.56	Iyz = 5882.48
Izx = -189.55	Izy = 5882.48	Izz = 23348.49

3.2. Working characteristics

Weight		
	Nanobell	3.4 kg
Current		
	Maximum operating voltage	70 kV
	Maximum operating current	500 μ A
Speed		
	Rotation speed	15 to 45 Krpm.
Paint		
	Paint flow rate	30 to 750 cc/ min. maxi (depending on paint used)
	Supply pressure	6 to 8 bar
	Maximum pressure	10 bar
	Viscosity	20 to 50 seconds - cup FORD # 4
	Viscosity	20 to 45 seconds - cup AFNOR # 4
Air pressure		
	Microvalve pilot	6 bar mini. - 10 bar maxi
	Bearing air	6 bar mini. - 10 bar maxi at 85NI/min.
	Shaping air	6 bar constant
	Microphone air	1,9 to 3 bar constant
Air quality		
	Filtered air (bearing air) must be dry and free of oil and dust as per DIN ISO 8573-1	
	Maximum dew point at 6 bar (87psi)	Class 4, i.e + 3° C (37° F)
	Maximum oil concentration	Class 4, i.e 2 mg / m ₀ ^{3**}
	Maximum particle size of solid contaminants	Class 3, i.e \varnothing 5 μ m
	Maximum concentration of solid contaminants	5 mg /m ₀ ^{3**}
Air consumption		
	Pilot	10NI/min.
	Bearing air	125NI/min.
	Shaping air	0 to 600 NI/min.according to the shaping air assembly used
	Turbine	see RT Nr 6350

** m₀³ values given for a temperature of 20°C (68°F) and an atmospheric pressure of 1,013 mbar.

3.3. Operating Principle

3.3.1. Turbine

[see RT Nr 6350](#)

This turbine has no mechanical shaft; it is centered by the polarity difference between the bearing magnets making it totally frictionless.

The bearing air evenly spread over the stator surface produces an air cushion that pushes the rotor away from the stator. The rotor can rotate freely, supported by the balance of pressure and magnetic forces. The air directed onto the turbine blades controls the rotation or braking of the rotor.

The product is atomized by the centrifugal forces created by the rotation of the bell cup. To some extent, the size of the atomized particles decreases as the rotation speed increases.

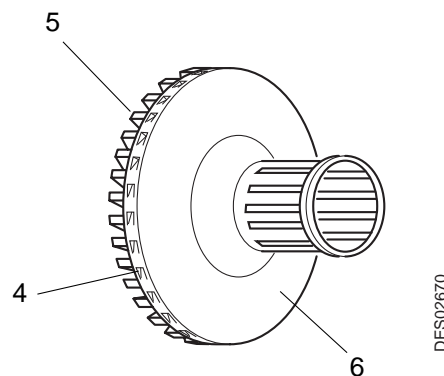
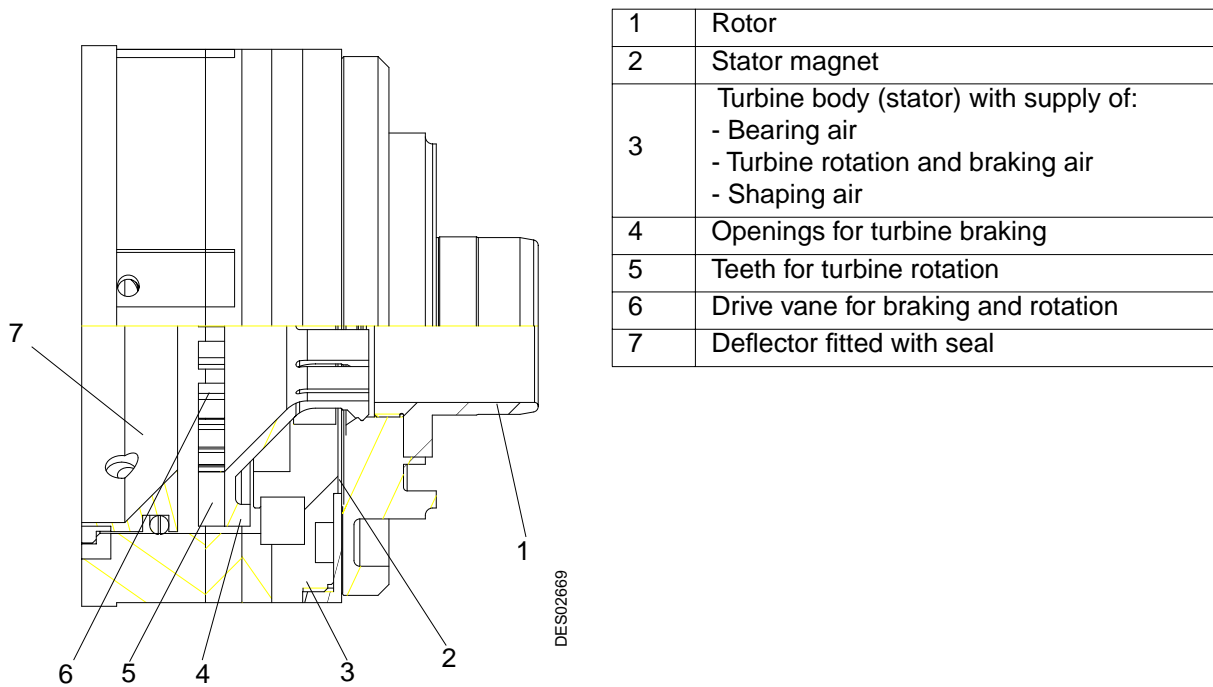

3.3.2. Turbine Rotation Speed

An acoustic method is used to measure rotation speed.

The air arrives at the injector holder. The channel machined in the 'microphone reader' located on the bellcup allows air to pass each time the bell cup rotates

This pressure variation induces a noise, or "frequency signal" which passes across the injector holder to reach a microphone.

This microphone converts the acoustic frequency signal into an electrical frequency signal for processing by the turbine speed regulation module.

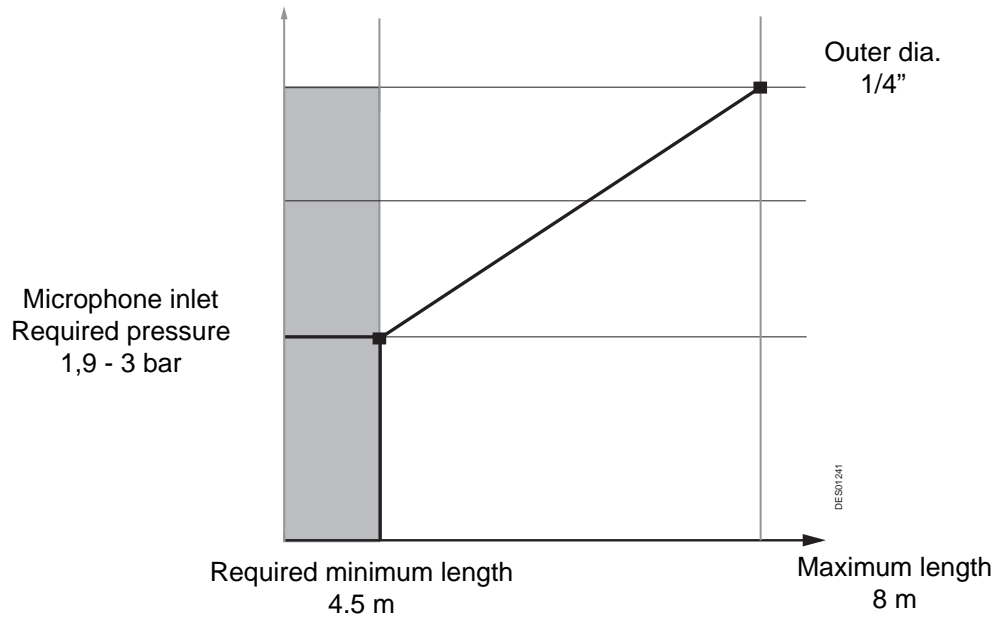

3.3.3. Microphone

[see RT Nr 6190](#)

The microphone will be associated a SAMES Frequency/Voltage converter which transforms the signal of analogical frequency into analogical signal of level (0 - 10 V) or numerical (pulsates).

Contact SAMES Technologies to obtain the adequate reference to the application.

4. Diagrams

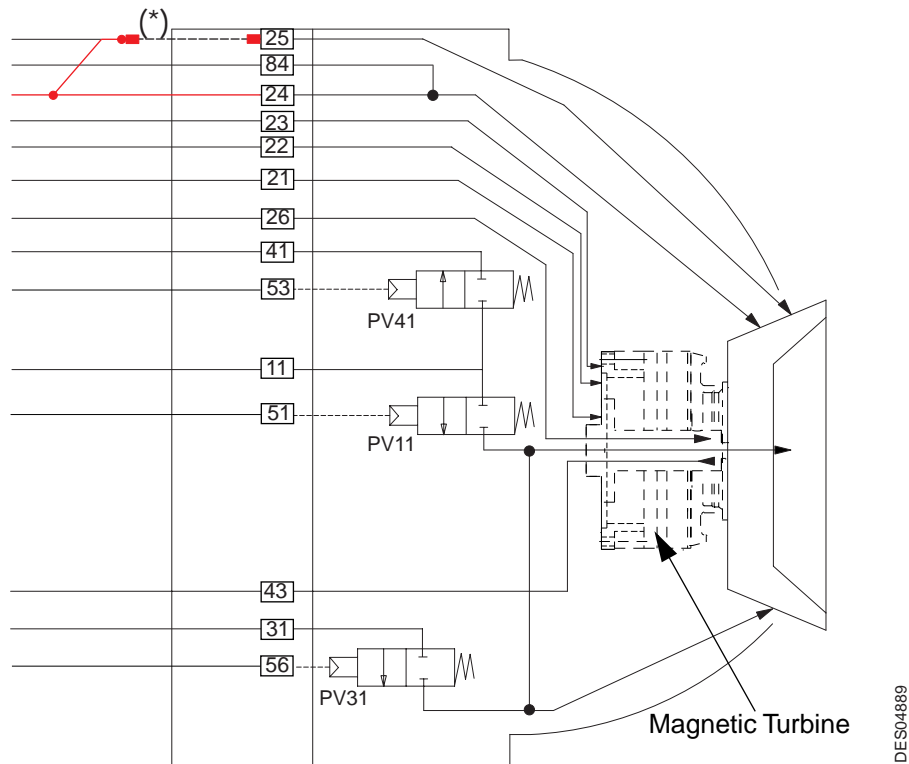

Item	Function	Hose Characteristics
11	Paint supply	D: 5/ 8 PTFE
21	Turbine rotation	D: 7/ 10 polyurethane
22	Turbine braking	D: 6/ 8 polyamide
23	Bearing air	D: 4/ 6 polyamide
24	Shaping air 1	D: 7/ 10 polyurethane
25	Shaping air 2	D: 7/ 10 polyurethane
26	Microphone air IN	D: 4/ 6 polyamide
31	Injector and Bell cup exterior rinsing air/solvent	D: 4/6 PTFE
41	Dump	D: 5/ 8 PTFE
43	Microphone return (OUT)	D: 4/ 6 polyamide
51	Pilot of paint supply	D: 2.7/ 4 polyamide
53	Dump pilot	D: 2.7/ 4 polyamide
56	Injector and Bell cup exterior rinsing air/solvent pilot	D: 2.7/ 4 polyamide
84	Remote 24-shaping air	D: 2.7/ 4 polyamide

PTFE hoses should be replaced neither by polyamide hoses nor by polyurethane hoses. Blue hoses are used for the different air supplies. The colourless hoses are used for the product.



WARNING : After a sequence of the exterior bell cup and injector, it is imperative to finish the rinsing sequence by a blowing of the "31" hose during 1 to 2 seconds.

The 41-hose (dump) must, for its part, be cleaned and blown during 1 to 2 seconds before switching on high voltage.



WARNING : (*)

On the Nanobell atomizer, a Y-union is installed on the shaping air input (hose, outer dia.: 12). The hoses (7/10 polyurethane, length 103mm) at exit of Y-union supply 24 and 25 inputs.

5. Startup

5.1. Tools

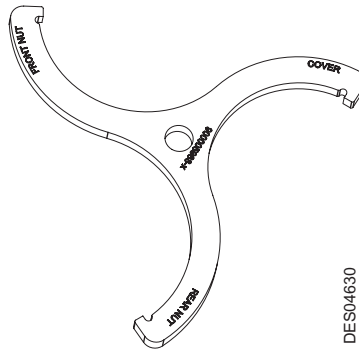

Part Number	Description	Qty	Sale unit
900005988	Installation / Removal tool for outer cover, rear and front nuts	1	1

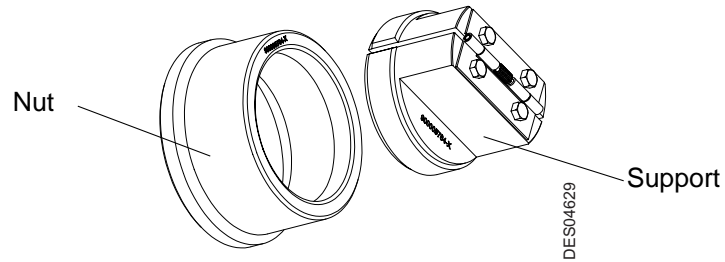

Part Number	Description	Qty	Sale unit
900005784	Removal tool for EC 35 magnetic bell cup	1	1

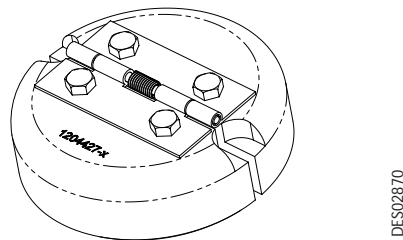

Part Number	Description	Qty	Sale unit
900000803	Removal tool for EC 50 magnetic bell cup	1	1

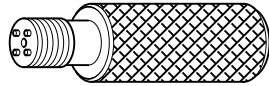

DES00039

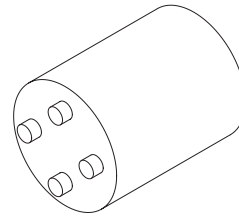

DES01673

Part Number	Description	Qty	Sale unit
1303689	Removal tool for microvalve	1	1
1403478	Automatic tightening tool for microvalve	1	1

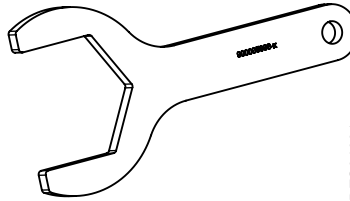

DES04631

Part Number	Description	Qty	Sale unit
900005996	Tool of tightening / loosening 64 on dishes	1	1

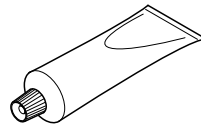

DES00685

Part Number	Description	Qty	Sale unit
H1GMIN017	White vaseline (100 ml)	1	1
H1GSYN037	Red dielectric grease for high voltage unit (50 g)	1	1

Additional tools and accessories required:

The tool listed below should be available for product installation and maintenance operations.

- Hose cutter (P/N.: W3SCTU002).
- Screwdriver (small and medium).
- Allen wrench (2.5 mm).
- Flat wrenches (4, 6, 14 and 18 mm)
- Open-socket wrench (6 mm)
- Fine brush.

5.2. Installation

For installation rules: [see § 1.4.1 page 10](#)

- **Step 1:** Install the robotic adapter specific to the robot to be equipped.
- **Step 2:** Remove the assembling flange of Nanobell, screw the atomizer via its equipped support and lock it with the tool (P/N 900005996) on the robot wrist.
- **Step 3:** Unscrew the nut of hose cover and slide hose cover on the high voltage cable. Pass high voltage cable into the black protective tube (direction: atomizer towards robot).



WARNING : 11-hose (5/8 PTFE) will have to be sheathed with a 9/12 PTFE hose. The overall length of the sheath must be approximately 5 cm lower than the length of the hose. Sheath will be fastening on the hose with two fittings Dia: 12/8 (P/N: 910006552):

On 11 hose, place the first fixing union which side body, place the sheath (PTFE hose) on the hose, screw the union. Place the second union at the other end and screw.

- **Step 4:** Pass all hoses through the black protective tube, the nut and the hose cover (direction: robot towards atomizer).
- **Step 5:** Connect hoses on the suitable unions.
- **Step 6:** Put in place the hose cover on the body, screw the elbow fitting and slide the nut of the hose cover then screw it using the tool 900005988, clip the black protective tube in the elbow fitting.



WARNING : The black protection tube is delivered in length of 3m.



WARNING : The plastic support (P/N 110000539AT) securing the black protective tube at its end will have to be fixed at 1m of the end of the hoses.

5.3. Shutdown and Startup Procedures

Important recommendations

Follow the air settings given in Section 3.2.

The rotor and stator will become unusable if the bearing air is cut.

The bearing air must be at least 6 bar at the inlet of the body.

(*For hose lengths greater than 4.5 m, measure the air pressure at the quick-disconnect plate to determine the correct setting).

Check that the speed regulating module transmits a signal.

5.3.1. Shutdown Procedure

Important steps to be observed:

		Step 1	Step 2	Step 3	Step 4	Step 5	Step 6
Stop atomizing	Sequence chart						
Switch off the high voltage power supply							
Run a rinsing cycle							
Run a blowing cycle of paint and solvent hoses							
Cut off the shaping air							
Cut off the turbine rotation air *							
Cut off the bearing air							



WARNING : * Wait until the turbine has completely stopped 0 rpm.

5.3.2. Startup Procedure

Important steps to be observed:

		Step 1	Step 2	Step 3	Step 4
Switch on the bearing air supply	Sequence chart				
Start up turbine rotation					
Switch on the shaping air supply					
Switch on the high voltage supply					
Start up atomization					

6. Maintenance

6.1. Summary table of maintenance operations

Procedure	Description	Preventive	Corrective	Duration	Frequency	
A	Cleaning of atomizer exterior, outer cover and bell cup	X		5 min.	8H	
B	B1	Cleaning of bell cup	X	2 min.	40H	
	B2	Cleaning of outer cover	X	8 min.	40H	
	B3	Cleaning of injector / injector holder	X	4 min.	40H	
	Body maintenance					
C	C1	Body installation / removal		X	5 min.	
	C2	Replacement of turbine		X	5 min.	> 10000 H
	C3	Replacement of solvent pipette		X	5 min.	> 10000 H
	C4	Replacement of microvalves		X	5 min.	2.5 millions cycles
	C5	Replacement of o-rings		X	15 min.	> 10000 H
	C6	Replacement of fittings		X	5 min.	> 10000 H
		Replacement of hoses		X	10 min.	12 to 24 months
	C7	Replacement of the equipped support		X	10 mn	-
	C8	Replacement of the placebo		X	5 min.	> 10000 H
C9	Replacement of high voltage cable		X	5 min.	> 10000 H	

6.2. Preventive maintenance

These maintenance operations can be performed online. Always refer to the health and safety instructions before carrying out any work ([see § 1.4 page 6](#)).

6.2.1. Procedure A: Atomizer exterior

At regular intervals during frequent use, and at the end of each cycle:

- Stop atomization, switch off the high voltage supply, (ensure that the GNM 200 control module does not deliver high voltage) and run a rinsing cycle.



WARNING : Always wear safety goggles.

Whenever solvent is handled, gloves made of an appropriate resistant material must be worn. Work in a well-ventilated area whenever solvent is used.



WARNING : Prior to cleaning, it is essential to eliminate all electrostatic charges on the atomizer using a cloth soaked with water then clean using a rag and an approved cleaning product. Do not use a manual solvent gun.



WARNING : Stop the turbine.

Under no circumstances must the atomizer or any of its components be sprayed with solvent or water at high or low pressure.



WARNING : Soak the body of the atomizer in a liquid of cleaning without integral disassembling of all its components is strictly prohibited. It is essential to remove bell cup, shaping air assembly, turbine, la turbine, microvalves, o-rings and fittings by using suitable tools ([see § 5.1 page 24](#)) then dry all the parts perfectly.

If this information is not respected, there is a risk of total deterioration of the atomizer imposing its replacement which is not covered by the Sames guarantee. It is in the same way strictly prohibited to soak the turbine in solvent.



WARNING : SAMES Technologies disadvises the use of protective plastic sheets.

If, despite this warning, plastic sheets are used to protect the atomizer, do not choose "anti-static" sheets as these conduct electricity and will short-circuit the high voltage if they are used to protect insulating parts such as the atomizer body.

Sames Technologies advises the use of textile cover or dielectric grease.



WARNING : In all the cases, the protections installed must be insulating to avoid any risk of over-consumption in current. This is why, these protections must be regularly replaced in order to keep an acceptable leakage current by the high voltage generator (of HV defaults will be able to appear if clogging in painting is too important).

1	Bell cup
2	Outer cover
3	Grooves in outer cover

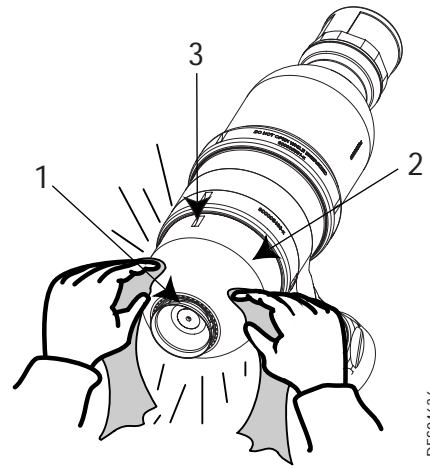

DES04636

- Clean the atomizer, the outer cover and the bellcup exterior using a clean rag.
- Check that the outer cover grooves are clean.
- Dry carefully with compressed air.

6.2.2. Procedure B1: Magnetic bell cup



WARNING : All bell cup maintenance or handling operations must be performed with extreme care, since the bell cup is balanced.



WARNING : Stop the turbine and cut off the shaping air supply, the bearing air remains pressurized.

- Remove the magnetic bell cup using the suitable tool, [see RT Nr 7071](#).
- Carry out a visual inspection.
- Let the bell cup soak for one hour in an appropriate solvent, then clean with a clean cloth and soft brush.



WARNING : Make sure that all surfaces are clean and free from impurities. Take care particularly of the internal and external surfaces of the cylinder of the bellcup fixing.

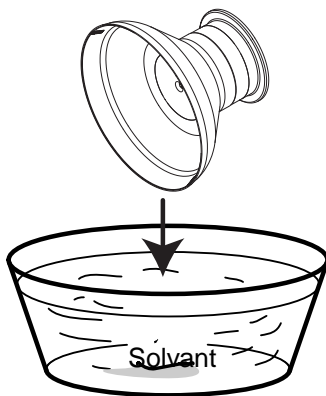

DES02662

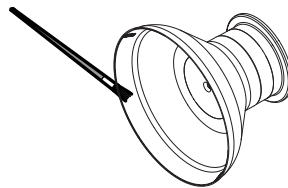

DES02663

- Dry carefully with compressed air.

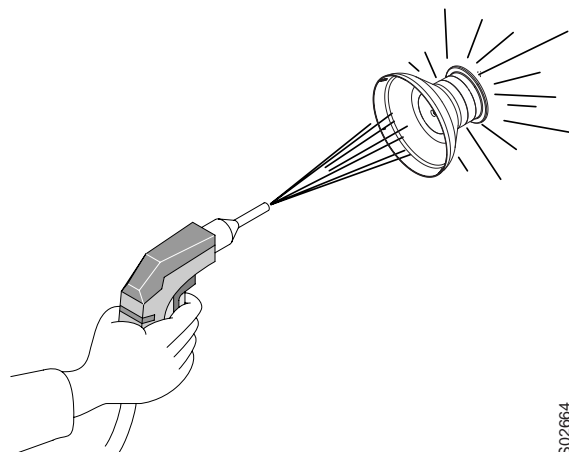

DES02664

- Reinstall the bell cup on the atomizer.

6.2.3. Procedure B2: Shaping air assembly

- The bell cup has been previously removed,
- Begin to loosen the outer cover with tool (P/N: 900005988), then continue manually.
- Remove the outer cover, then the shaping air shroud.
- Carry out a visual inspection of the three components (jouter cover, shaping air shroud and o-ring) replace if necessary, then clean the outer cover:

- **Step 1:** Let the outer cover soak for one hour in an appropriate solvent then clean the outer and inner surfaces with a clean cloth soaked in solvent.

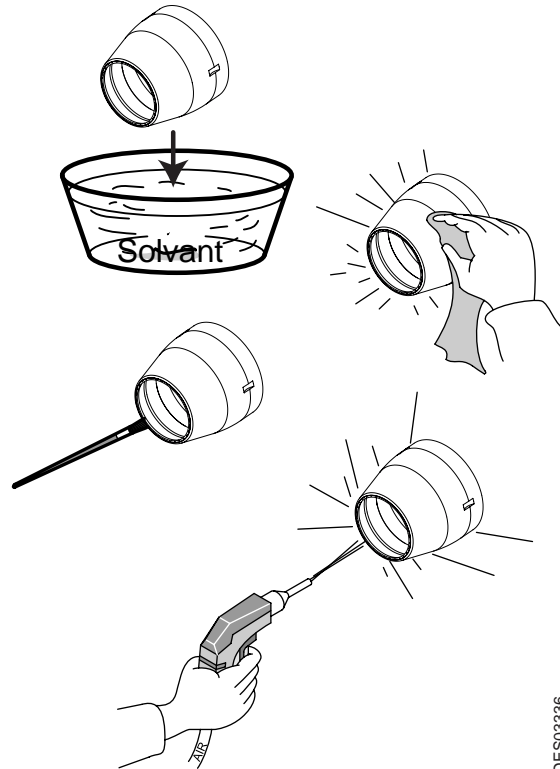

- **Step 2:** Use a nylon brush to clean the holes on the front face of the outer cover.

- **Step 3:** Dry carefully with compressed air (concentrating on the holes to eliminate paint residues) then wipe with a clean, dry cloth.

- Check the condition of the inner shaping air shroud and, if necessary, clean it with a cloth soaked in solvent.

- Reinstall the shaping air assembly, [see RT Nr 7071](#).



WARNING : Keep the threading between the outer cover and the body clean. It is imperative to coat the threading with vaseline to facilitate the reinstallation of the outer cover.

6.2.4. Procedure B3: Injector / Injector holder assembly

- Bell cup, shaping air assembly, and turbine has been previously removed,

- **Step 1:** Using a 4mm-flat wrench, unscrew the injector (in the clockwise direction) and remove it, taking care not to damage the injector and its o-rings.



- **Step 2:** Leave to soak for one hour in a suitable solvent, then dry carefully with compressed air. Check the o-rings, replace if necessary.

- **Step 3:** Place the injector onto the injector holder and tighten by turning clockwise to a maximum torque of 3.5 Nm.

- **Step 4:** If necessary, remove the injector holder, Untighten the 3 screws securing the injector holder using the 2.5 mm allen key. For re-assembling, tighten the screws to a maximum torque of 1,7 N.m.



3 - C M 3x10
screws

6.3. Corrective maintenance

The following operations are preferably performed in a workshop.

6.3.1. Procedure C1: Body installation / removal

- Loosen the elbow fitting using tool (P/N 900005996), loosen the nut of hose cover using tool (P/N 900005988) and slide the hose cover onto hoses to be able to have access to the fittings.
- Disconnect the hoses one by one.
- Remove bell cup, shaping air assembly and turbine, and if necessary the injector / injector holder assembly.

- Unscrew the front nut using tool (P/N 900005988), slide the body.
- Loosen the fastening screw. Withdraw the high voltage unit.

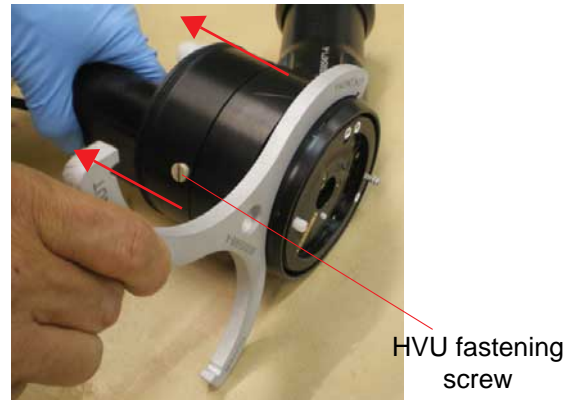

- **Reinstall the body:** Proceed in reverse order.

6.3.2. Procedure C2: Replacement of turbine

- **Remove the turbine:**
Loosen the five screws fixing the turbine on the body using a 2.5mm- allen wrench. Pull the turbine along the axis.



- **Install the turbine:**
Install and secure the turbine on the body with the five screws (tightening torque: 1,5Nm).

6.3.3. Procedure C3: Replacement of solvent pipette

- **Remove the solvent pipette:**

Unscrew the solvent pipette using a 4mm-flat wrench.

Change systematically the o-ring (P/N J3STKL027) situated in bottom of the pipette-housing. Remove it using a small hook then push a new o-ring in the pipette housing using an allen wrench.



Replace and screw the new pipette in the body. The pipette shoulder must slightly be placed into the body.



Nota: Check the condition of the o-rings on the solvent pipette each time the outer cover is removed.

6.3.4. Procedure C4: Replacement of microvalves

- Unscrew the front nut using tool (P/N: 900005988).



- Slide the body support to be able to have access to the microvalves.

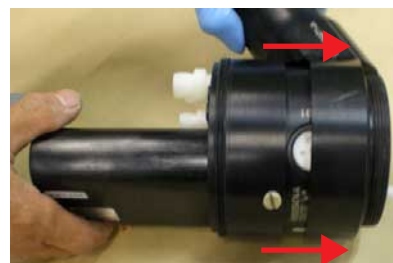

- **Remove the microvalves:**

[see RT Nr 6021](#) for the operations listed below. Remove the microvalves using tool (P/N 1303689).

Check the condition of the microvalves, clean them and replace if necessary.

Before re-assembling, coat the threading of the microvalves with vaseline grease.



6.3.5. Procedure C5: Replacement of body o-rings

- Check the conditions of the o-rings and replace if necessary.

O-ring kit (turbine side): 1527518.

Prior to reinstalling the body, make sure all the o-rings are present.



6.3.6. Procedure C6: Replacement of fittings and hoses

- Loosen the elbow fitting using tool (P/N 900005996), loosen the nut of hose cover using tool (P/N 900005988) and slide the hose cover onto hoses to be able to have access to the fittings.
- Loosen the fitting nut(s) to be replaced using a suitable flat wrench, disconnect the hose(s).
- Loosen the fitting(s) and withdraw from the body.

- To merely replace the fitting, cut the hose approximately 20 mm from its end using the tube cutter (P/N W3SCTU002). Caution: the cutting plane must be perfectly perpendicular to the hose.



Reinstallation of fittings:

- Place PTFE tape on fitting threading, then screw each fitting into the body using a 14 or 18mm- flat wrench according to the diameter.



PTFE tape

- Push the hose into the fitting and tighten the nut on the hose.
- **To replace the hose**, use the old hose to pull the assembly until the new hose protrudes from the body to connect it on the fitting.



WARNING : Replace all hoses every 12 to 24 months, depending on the amount of use.

6.3.7. Procedure C7: Replacement of the equipped support

- Loosen the front nut using the tool (P/N 900005988).
- Separate the atomizer with tool and shaping air assembly from the support du support.
- Loosen the nut (P/N 900004885) using the tool (P/N 900005996).
- Replace the equipped support.

For re-assembling: proceed in reverse order

6.3.8. Procedure C8: Replacement of the placebo

- Loosen the elbow fitting using tool (P/N 900005996), loosen the nut of hose cover using tool (P/N 900005988) and slide the hose cover onto hoses to be able to have access to the placebo.

- To withdraw the placebo, loosen the fastening screw until see the o-ring and pull the placebo along the axis .

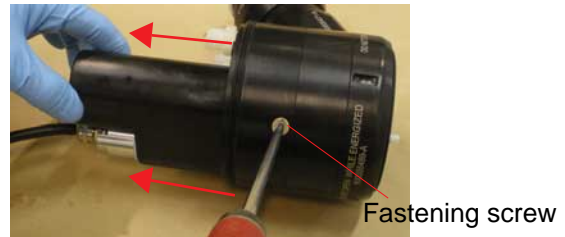

- **Install the placebo:** Coat the high voltage well (body side and placebo side) with red dielectric grease. Screw the securing device. Install the insulator , then tighten with a 6mm-open-socket wrench by positioning it on the dishes of the banana plug. Push the placebo in all the way and fasten the fastening screw. Connect the high voltage cable. Connect the ground wire to the securing device.

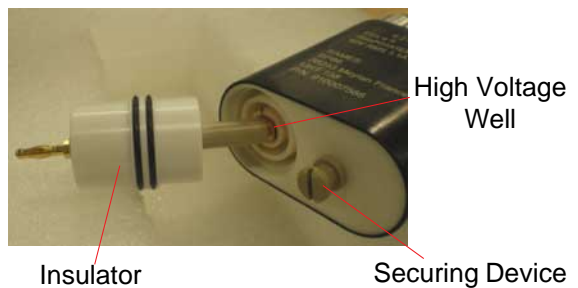

6.3.8.1. Procedure C9: Preparation of the high voltage connection

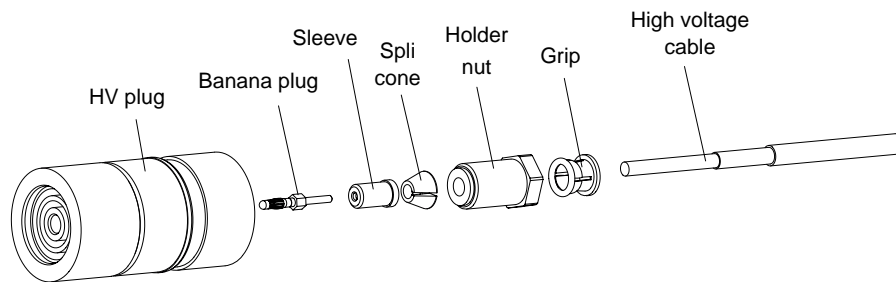

DES04190



WARNING : Ensure not to damage the insulating jacket. The smallest nick or mark in the insulating jacket will cause the cable to breakdown.

- **Step 1:** Strip using a tool type strip-cable (rice-grain) the high voltage cable over 22.5 length for the violet sheath. It is imperative not to use a standard tool slicing "cutter" Then strip the semiconductor sheath (black sheath) over 19 cm length by peeling it and cut it using pliers.
- **Step 2:** Insert the seal then the grip in the nut.
- **Step 3:** Thread the nut equipped, split cone and sleeve must be kept against the cable.



Step 1

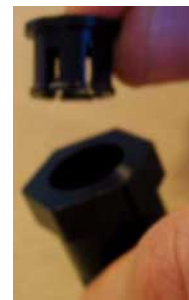

Step 2



Step 3

- **Step 4:** Insert the banana plug in the high-voltage cable, screw it manually then using a 6 mm open end wrench, tighten it until it stops.



Step 4





- **Step 5: Greasing**
 - Coat the high voltage connection assembly (banana plug, sleeve, split cone, grip holder) with a fine layer of dielectric grease.
- **Step 6:** Pass the high voltage cable as above through the high voltage plug. Install the HV plug on the equipped cable, tighten the grip holder nut on the plug with an open end wrench. Connect the 10/12 protective tube in the grip. Coat sufficiently with dielectric grease the baffle plates of the plug and the outside of the plug with a brush.



WARNING : The high voltage must be imperatively sheathed with a 10/12 polyamide tube.

7. Spare parts list

Bell cup and shaping air assemblies are not included.

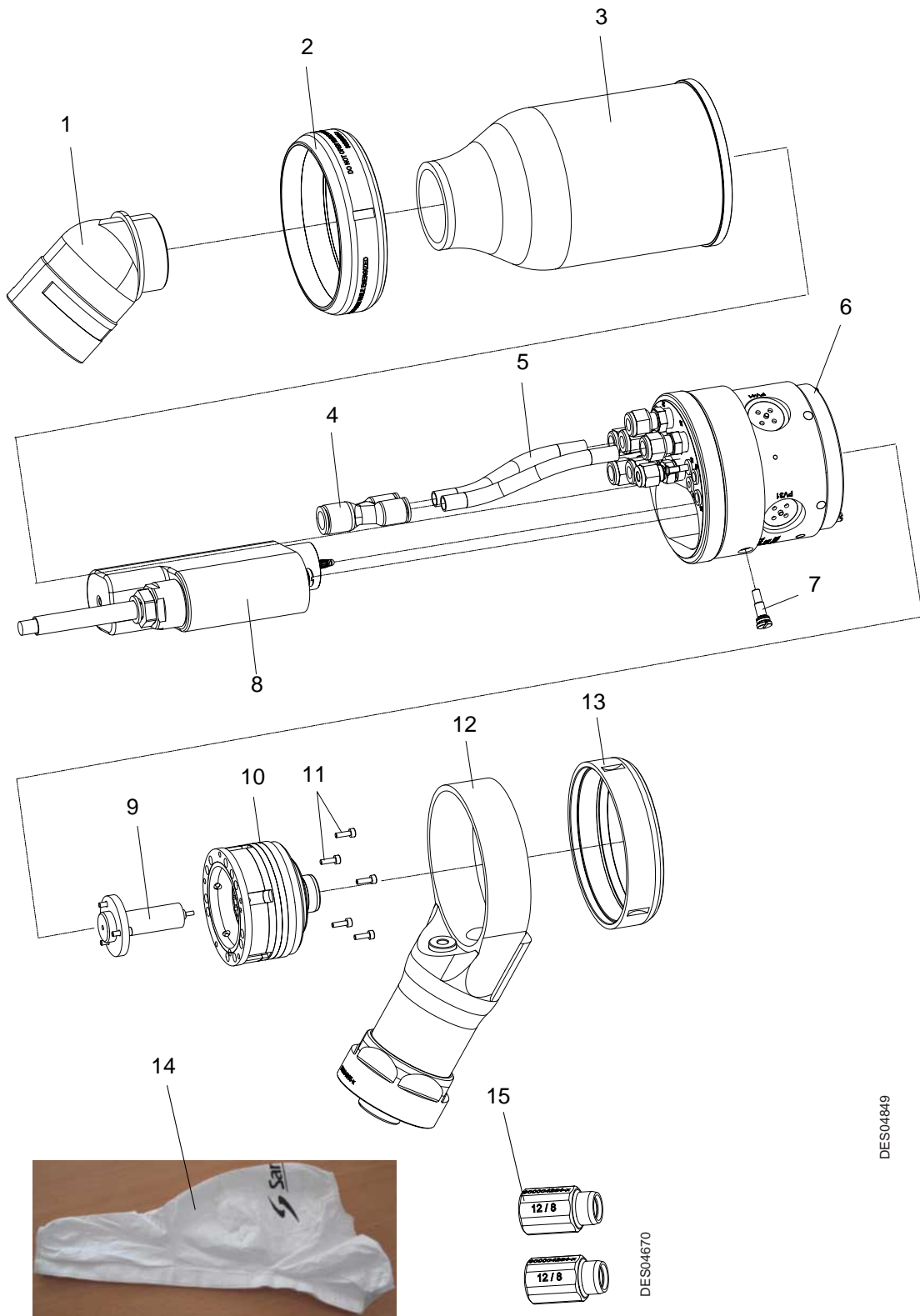

Item	Part number	Description	Qty	Unit of sale	Maintenance level for spare part (*)
	910008556	Nanobell Hi-Te WB	1	1	3
1	110001074AT	Elbow fitting	1	1	3
2	900005561	Nut of hose cover	1	1	3
3	910008357	Hose cover	1	1	3
4	130000793	Y union	1	1	2
5	U1GLBT133	Polyurethane blue hose Dia: 10 x 3,5 (on 24 and 25 fittings)	2 x 0,103	m	2
6	910007461	Equipped body (see § 7.1 page 42)	1	1	3
7	910008218	Fastening screw of high voltage unit	1	1	1
8	910008496	Placebo UHT 158 EEx e (see § 7.4 page 46)	1	1	3
9	910001130	Injector / Injector holder assembly (see § 7.3 page 45)	1	1	3
10	1525802	S12 magnetic air bearing turbine type BTM (see RT Nr 6350)	1	1	3
11	X4FVSY067	Screw Chc M 3 x 10 ss 316	5	1	3
12	910007374	Equipped support (see § 7.2 page 44)	1	1	3
13	900005489	Nut	1	1	3
14	900006143	Protection sleeve	1	1	-
15	910006552	Sheath fixing union	2	1	3
Not shown					
-	110000540AT	Black protective tube	3	m	3
-	110000539AT	Plastic support	1	1	3

(*)

Level 1: Standard preventive maintenance

Level 2: Corrective maintenance

Level 3: Exceptional maintenance

7.1. Equipped body

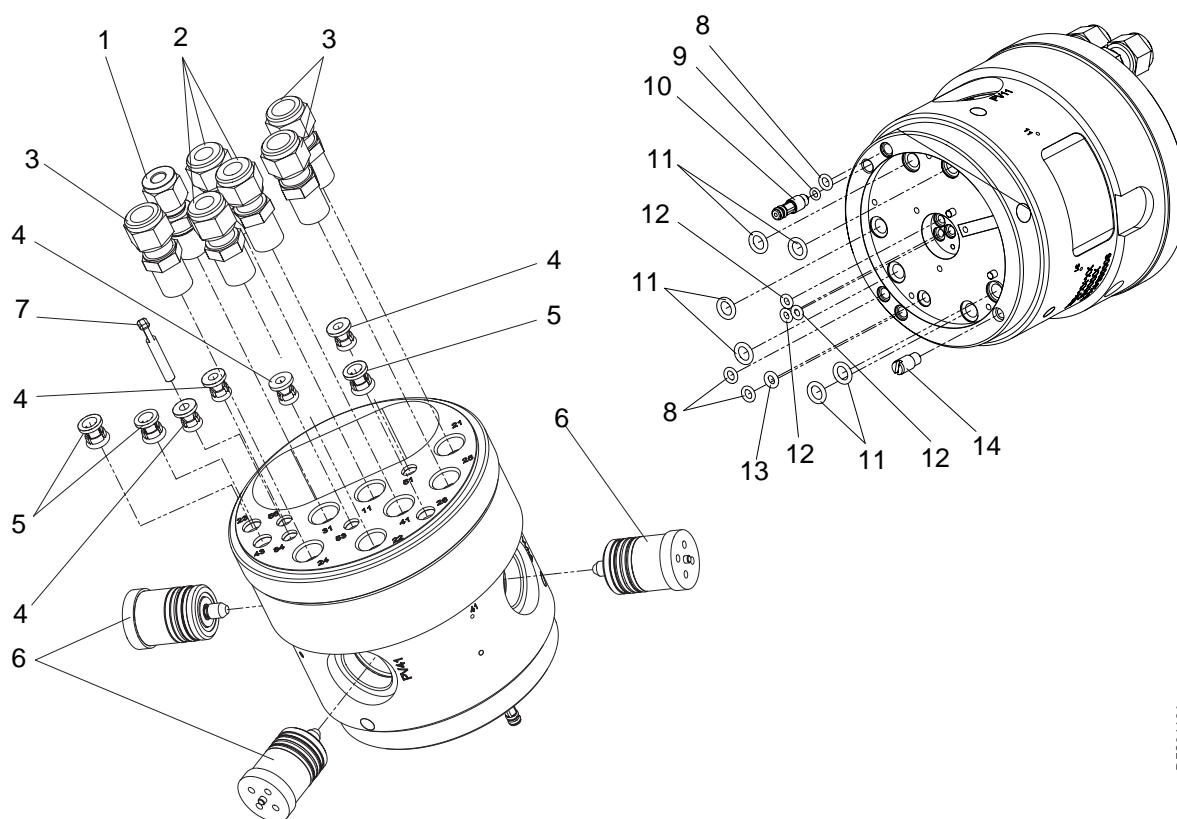

DES04621

Item	Part number	Description	Qty	Unit of sale	Maintenance level for spare part (*)
	910007461	Equipped body	1	1	3
1	F6RPUQ092	Male fitting D: 6 1/4G	1	1	1
2	F6RPUQ093	Male fitting D: 8 1/4G	3	1	1
3	F6RPUQ094	Male fitting D: 10 1/4G	3	1	1
4	F6RXZG081	Stainless steel grip and seal	4	1	2
5	F6RXZG082	Stainless steel grip and seal	3	1	2
6	1507375	Microvalve, 2 ways, orange indicator with chemically inert o-rings (see § page 4)	3	1	1
7	F6RLZX398	Quick release plug	1	1	3
8	J3STKL039	O-ring - chemically inert	3	1	1
9	J3STKL027	O-ring - chemically inert (included in item 10)	1	1	1
10	910008194	Solvent pipette	1	1	1
11	J2FTDF075	O-ring - viton	6	1	1
12	J3STKL002	O-ring - chemically inert	3	1	1
13	J2FTDF035	O-ring - viton	1	1	1
14	1402691	Shaping air alignment pin	1	1	3

(*)

Level 1: Standard preventive maintenance

Level 2: Corrective maintenance

Level 3: Exceptional maintenance

O-ring set

Item	Part number	Description	Qty	Unit of sale	Maintenance level for spare part (*)
	1527518	O-ring set (turbine side)	1	1	1
8	J3STKL039	O-ring - chemically inert	3	1	1
11	J2FTDF075	O-ring - viton	6	1	1
12	J3STKL002	O-ring - chemically inert	3	1	1
13	J2FTDF035	O-ring - viton	1	1	1

Fitting set

Item	Part number	Description	Qty	Unit of sale	Maintenance level for spare part (*)
	910004632	Fitting set	1	1	1
1	F6RPUQ092	Male fitting D: 6 1/4G	1	1	1
2	F6RPUQ093	Male fitting D: 8 1/4G	3	1	1
3	F6RPUQ094	Male fitting D: 10 1/4G	3	1	1
4	F6RXZG081	Stainless steel grip and seal	4	1	2
5	F6RXZG082	Stainless steel grip and seal	3	1	2
7	F6RLZX398	Quick release plug	1	1	3

Location of fittings

Item	Location
1	on 31
2	on 11, 22 and 41
3	on 21, 24 and 25
4	on 51, 53, 56 and 84
5	on 23, 26 and 43
7	on 84

84: plug-in the shaping air pressure,

A plug is placed by default otherwise install a 2.7/4 hose to be able to measure the shaping air pressure: diagrams [see § 4 page 22](#)).

7.2. Equipped Support

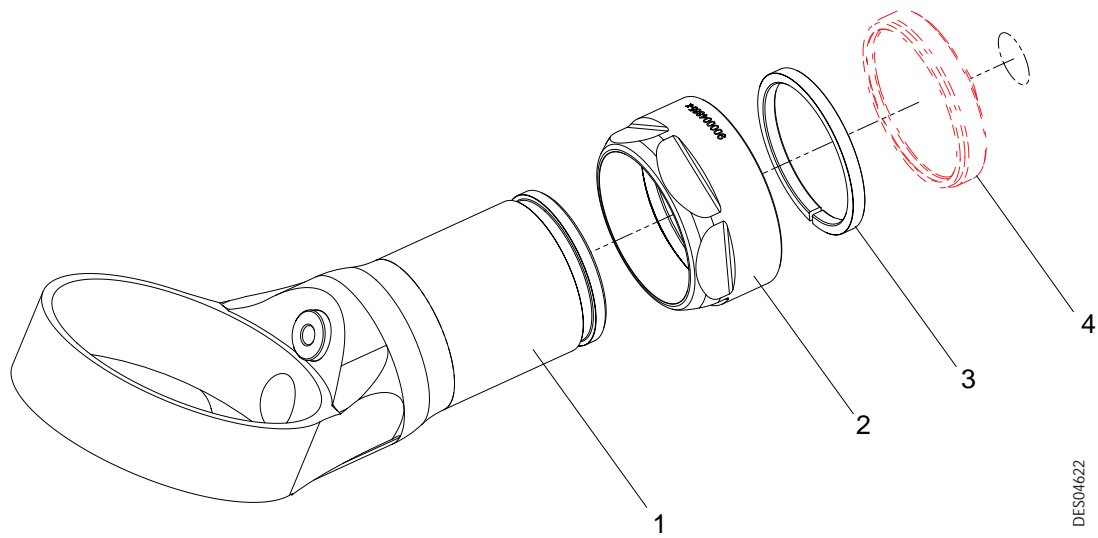

Item	Part number	Description	Qty	Unit of sale	Maintenance level for spare part (*)
	910007374	Equipped support	1	1	3
1	900005918	Body support	1	1	3
2	900004885	Nut	1	1	3
3	900004884	Split ring	1	1	1
4	-	Assembling flange	1	-	-

(*)

Level 1: Standard preventive maintenance

Level 2: Corrective maintenance

Level 3: Exceptional maintenance

7.3. Injector / injector holder

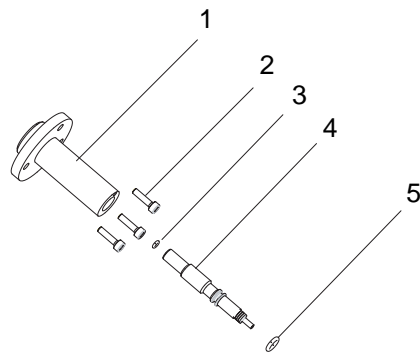

DES02117

Item	Part number	Description	Qty	Unit of sale	Maintenance level for spare part (*)
	910001130	Injector / injector holder assembly	1	1	3
1	738354	Injector holder	1	1	3
2	X4FVSY067	Screw C M 3 x 10 - stainless steel	3	1	1
3	J3STKL014	O-ring - chemically inert	1	1	1
4	738635	Injector Dia: 1.8	1	1	1
5	J3STKL005	O-ring - chemically inert	1	1	1

(*)

Level 1: Standard preventive maintenance

Level 2: Corrective maintenance

Level 3: Exceptional maintenance

7.4. Placebo UHT 158 without resistor

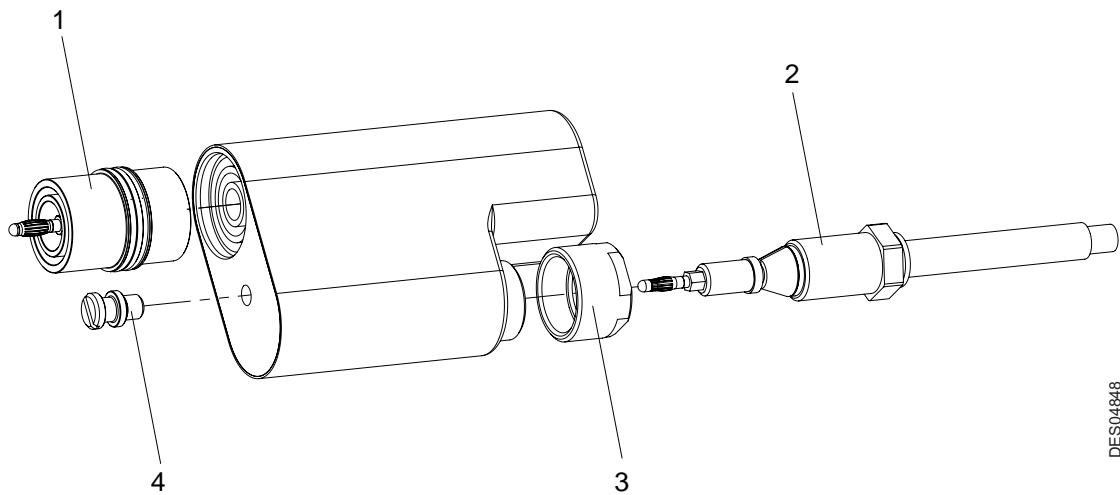

DES04848

Item	Part number	Description	Qty	Unit of sale	Maintenance level for spare part (*)
	910008496	Placebo UHT 158 without resistor	1	1	3
1	910008345	Insulator	1	1	3
2	910008349	High voltage connection (see § 7.4.1 page 47)	1	1	3
3	900006083	Placebo cover	1	1	3
4	900005491	Securing device	1	1	3

(*)

Level 1: Standard preventive maintenance

Level 2: Corrective maintenance

Level 3: Exceptional maintenance

7.4.1. High voltage connection

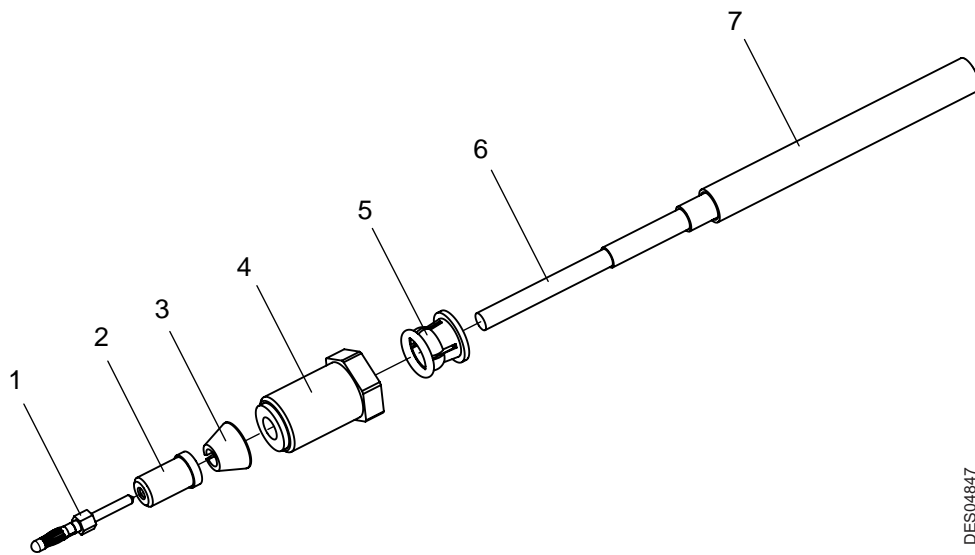

DES04847

Item	Part number	Description	Qty	Unit of sale	Maintenance level for spare part (*)
	910008349	High voltage connection	1	1	3
1	E4CSHT181	Banana plug	1	1	3
2	1411690	Sleeve, 100kV cable end	1	1	3
3	1411689	Split cone	1	1	3
4	1315058	Nut, grip holder	1	1	3
5	F6RXZG085	Stainless steel grip+ seal	1	1	3
6	E2DAVD101	High voltage cable 100kV	18 m	m	1
7	U1CBBR057	Protective tubing, HV cable, Dia:10/12 colorless polyamide	18 m	m	1
	910003570	Set of ground connection for cable shielding	-	1	-

(*)

Level 1: Standard preventive maintenance

Level 2: Corrective maintenance

Level 3: Exceptional maintenance

Nota: The cable is delivered prepared at its two ends according to the high voltage unit and to the atomizer.

For the installation described in paragraph 1.4.1, it is necessary to cut the cable to the correct plate according to the installation (adjustment of the distances between HVU / insulating table and HVU / atomizer) and prepare the two ends so obtained according to the method described ([see § 6.3.8.1 page 38](#) step 1) by adapting the stripped lengths so as to:

- ensure a mini distance of 250 mm mini between the shielding and any part with high voltage.
- ensure the ground connection of the shielding of the connecting cable HVU / Insulating table at the exit of the cage using the set (P/N 910003570).

Remarks: For any length request higher than 18m, contact Sames Technologies.

7.5. Robot adapters

7.5.1. Adapter for Motoman PX 1450 robot

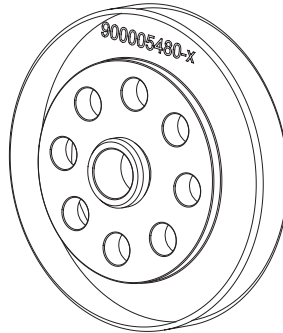

DES04632

Part number	Description	Qty	Unit of sale	Maintenance level for spare part (*)
910008322	Robot adapter	1	1	-

7.5.2. Adapter for ABB IRB 540 robot

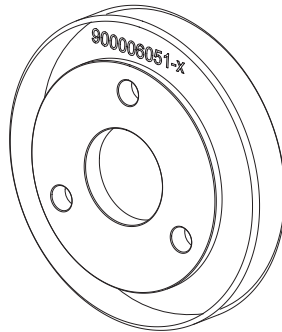

DES04633

Part number	Description	Qty	Unit of sale	Maintenance level for spare part (*)
910008325	Robot adapter	1	1	-

7.5.3. Adapter for Kawasaki KF 121 robot

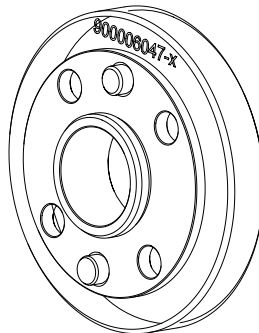

DES04634

Part number	Description	Qty	Unit of sale	Maintenance level for spare part (*)
910008324	Robot adapter	1	1	-

7.5.4. Adapter for Staubli TX 60 robot

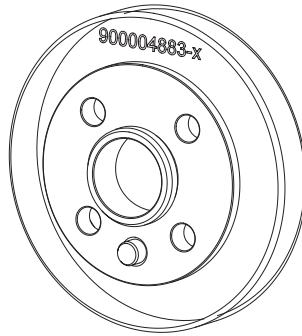

Part number	Description	Qty	Unit of sale	Maintenance level for spare part (*)
910008323	Robot adapter	1	1	-