



From February 1st, 2017 SAMES Technologies SAS becomes SAMES KREMLIN SAS
A partir du 1/02/17, SAMES Technologies SAS devient SAMES KREMLIN SAS



User manual

Powder Supply Unit EasyCompact



SAS SAMES Technologies. 13 Chemin de Malacher 38243 Meylan Cedex
Tel. 33 (0)4 76 41 60 60 - Fax. 33 (0)4 76 41 60 90 - www.sames.com

All communication or reproduction of this document, in any form whatsoever and all use or communication of its contents are forbidden without express written authorisation from SAMES Technologies.

The descriptions and characteristics mentioned in this document are subject to change without prior notice.

© SAMES Technologies 2006



WARNING: SAS Sames Technologies is registered with the Ministry of Labour as a training institution.
Throughout the year, our company offers training courses in the operation and maintenance of your equipment.
A catalogue is available on request. Choose from a wide range of courses to acquire the skills or knowledge that is required to match your production requirements and objectives.
Our training courses can be delivered at your site or in the training centre at our Meylan head office.

Training department:
Tel. 33 (0)4 76 41 60 04
E-mail: formation-client@sames.com

SAS Sames Technologies operating manuals are written in French and translated into English, German, Spanish, Italian and Portuguese.

The French version is deemed the official text and Sames will not be liable for the translations into other languages.

Powder Supply Unit EasyCompact

1. Safety	4
1.1. Associated documents	4
1.2. Safety Regulations	4
1.3. Compliance with the ATEX directive	6
1.4. Back-end risks	7
2. Description	8
2.1. General description	8
2.2. Powder supply unit equipment	8
2.3. Control devices	8
2.3.1. Cabinet	8
2.3.2. Operator terminal	8
2.4. Description of operation	8
2.5. Features	9
2.5.1. Electrical features	9
2.5.2. Pneumatic features	9
2.5.3. Weight and dimensions	9
2.5.4. Equipment dimensions	10
2.5.5. Noise emission	11
2.5.6. Powder supply unit handling method	11
3. Commissioning and settings	12
3.1. Vibrator	12
3.2. Plunger cylinder restrictor	14
3.3. End of stroke sensors	14
3.4. Powder level detector	14
3.5. Setting the ventilation	15
3.6. Locking the carton or tank in place	15
3.7. Electro-pneumatic valve supply	15
3.8. Setting the fluidisation	16
3.9. Plunger carriage downwards control	16
4. Operating procedure	16
5. Maintenance	17
5.1. Preventive maintenance	17
5.2. Corrective maintenance	18
5.2.1. Troubleshooting	18
6. Spare Parts	19
6.1. Vibrating table	19
6.2. Carriage assembly	20
6.3. Powder Supply Unit	21

1. Safety

1.1. Associated documents

NB: This document contains links to the following user manuals:

[see RT Nr 6336](#) For the "Mach-Jet Gun" spray gun

[see RT Nr 6366](#) For the "Auto Mach-Jet" automatic spray gun

See supplier's notice for the filtering box

[see RT Nr 7022](#) For the PVV EasyCompact booth

[see RT Nr 7023](#) For the EasyCompact recycling system

[see RT Nr 7015](#) For the PVV EasyCompact installation.

[see RT Nr 6368](#) For the CS 127 powder pump.

1.2. Safety Regulations



WARNING: This equipment may be dangerous if it is not used in strict compliance with the safety regulations specified in this user manual. It is essential for the operator to be aware of the back-end risks in using the equipment.

[see § 1.4 page 7.](#)

- 1 The powder supply unit, particularly the plunger carriage, should be connected electrically to the earth system protecting the electric power supply.
- 2 All conducting structures inside or near the work powder supply unit should be connected electrically to the earth system protecting the electrical power supply.
- 3 Grinding or welding of metal products carried out less than five metres from the powder supply unit is prohibited unless the following safety measures are implemented:
 - The powder supply unit should be protected by a tarpaulin in non- (or only slightly-)flammable material.
 - A person armed with a fire extinguisher should monitor the powder supply unit area during the work
- 4 The powder supply unit must not support any weight other than that of equipment originally intended to be installed on or around it. The powder supply unit is an independently stable structure. Under no circumstances is it designed to support the weight of an operator working on its roof, the weight of another part of the building or any other load.
- 5 It is essential to comply with the SAMES recommendations when modifying the powder supply unit.
- 6 The floor underneath the powder supply unit should be resistant to over 400 kN/m².
- 7 The temperature at the powder supply unit walls should not exceed 40°C. The ambient temperature or the temperature of any heat source near its walls should not exceed 40°C.
- 8 Do not bring corrosive products in contact with the powder supply unit or anything likely to damage its surface.

- 9 The recycling pipe (TR) must be connected to the powder tank (RE) via the box (BO) under normal operation.



- 10 Check the equipotential link to the powder supply unit earth periodically.
11 Connect imperatively the carriage to the ground via the ground bar of the terminal box.



1.3. Compliance with the ATEX directive

Under Directive 1999/92 EC, the user is responsible for defining the ATEX zones. In accordance with standard EN 12981, Sames Technologies has designed the EasyCompact installation taking the following zones into account:

- **Powder feed centre:**
 - Zone 20 for the internal volume of the powder fluidisation tank.
 - Zone 22 for the inside volume of the powder supply unit.

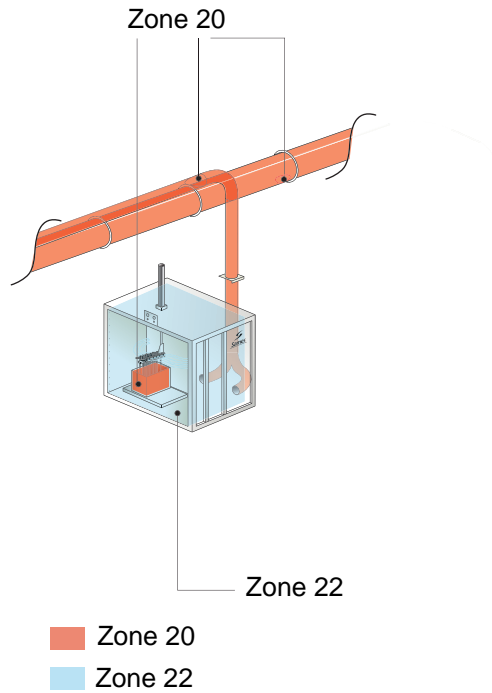

1.4. Back-end risks

Refer to installation-related risks [see RT Nr 7015](#).

Risk/Hazard	Severity	Frequency and duration of exposure	Methods applied to limit the damage
Noise hazards (see noise measuring sheet see RT Nr 7015 .)	Slight	All operators working on the installation	Use individual protection equipment (helmet, etc.)
Risks from inhaling harmful fumes and dust	Slight	Operator assigned to cleaning the powder supply unit during cleaning phases	Wear a protective mask during cleaning phases
Risks of falling when working on the upper section of the powder supply unit	Serious	Every time a single operator works on the upper section of the powder supply unit	Use secure means to work on the upper section of the powder supply unit
Part of the body crushed by the cylinder	Serious	All operators working on the installation	Cylinder control located remotely and prior operator training

2. Description

2.1. General description

The powder powder supply unit is a ventilated chamber used for:

- 1 Supplying all the various types of spray gun (maximum 24) with powder
- 2 Automatically cleaning:
 - powder pumps,
 - powder supply hoses,
 - inside all the types of spray gun,
 - powder recycling pipe and sifter (in Easy-color PVV installation).

On a PVV installation, it is controlled by the PLC located on the front panel of the electrical cabinet.

The powder powder supply unit may operated autonomously as an option.

In this case, it is controlled from the keyboard located on the front panel for the electro-pneumatic cabinet.

The PLC monitor allows the operator to plan and monitor his actions in real time.

It shows the operator the state of the powder powder supply unit (defects, cleaning stages, forthcoming operations).

2.2. Powder supply unit equipment

The powder powder supply unit is fitted with the following safety devices and equipment:

- Emergency stop push-buttons on the front panels of both the electrical cabinet and the powder supply unit
- Powder level detector in the container
- Quick-disconnect locking system for the powder recycling pipe in cleaning position
- Compressed air blower assembly to clean the powder supply unit
- 2 neon tubes to light the powder supply unit
- "Plunger carriage down" push-button

2.3. Control devices

2.3.1. Cabinet

Refer to the detailed functional analysis provided by the automatic control section.

2.3.2. Operator terminal.

Refer to the detailed functional analysis provided by the automatic control section.

2.4. Description of operation

Refer to the detailed functional analysis provided by the automatic control section.

2.5. Features

2.5.1. Electrical features

Vibrator

Protection rating	EEx e II
Classification	group II, category 2D
Power-supply voltage	230 V/400 V 3-phase + earth
Frequency	50/60 Hz
Power	94 W
Index of protection	IP 66-7
Insulation rating	F
Weight	12.8 kg

2.5.2. Pneumatic features

2.5.2.1. Powder supply unit

Max. input pressure	8 bar (120 psi)
Min. input pressure for a flow rate of 17 m ₀ ³ / h	6 bar (90 psi)
Max. compressed air consumption	17 m ₀ ³ /h

2.5.2.2. Required characteristics for compressed-air supply according to standard NF ISO 8573-1:

Compressed air characteristics	NF ISO 8573-1
Dew point	Class 4, i.e. +3°C (37°F)
Max. particle size of solid pollutants	Class 3, i.e. 5 µm
Max. concentration of solid pollutants	Class 3, i.e. 5 mg/m ₀ ³ *
Max. oil concentration	Class 1, i.e. 0.01 mg/m ₀ ³ *

* m₀³: values given for a temperature of 20 °C (68°F), at atmospheric pressure (1,013 mbar).

2.5.2.3. Ventilation required

Ventilation required	2500 m ₀ ³ /h minimum
----------------------	---

2.5.3. Weight and dimensions

2.5.3.1. Powder supply unit

Weight	roughly 400 kg
Width	1,600 mm
Depth	1,350 mm
Height	2,600 mm

2.5.4. Equipment dimensions

2.5.4.1. Plunger cylinder

Stroke	600 mm
--------	--------

2.5.4.2. Large fluidisation tank

Length	900 mm
Width	595 mm
Height	415 mm
Useful volume	160 l

2.5.4.3. Medium-sized fluidisation tank

Length	620 mm
Width	595 mm
Height	415 mm
Useful volume	120 l

2.5.4.4. Small fluidisation tank

Length	425 mm
Width	595 mm
Height	415 mm
Useful volume	90 l

2.5.4.5. Carton (powder supplier)

Min. length	380 mm
Min. width	280 mm
Max. height	400 mm
Useful volume (depending on carton)	40 to 50 l

2.5.4.6. Maximum number of powder pumps

Version (carton)	14
Version (fluidisation tank)	24

2.5.5. Noise emission

The acoustic pressure measured in front of the powder supply unit at the operator powder supply unit should not exceed 80 dB(A); refer to the noise measurement at work powder supply unit sheet in the installation instructions [see RT Nr 7015](#).

It is advisable to wear suitable hearing protection during cleaning phases.

2.5.6. Powder supply unit handling method

Use lifting equipment (transpallet or fork lift) of sufficient capacity to move the powder supply unit. Comply strictly with the powder supply unit gripping position given in the diagram below.

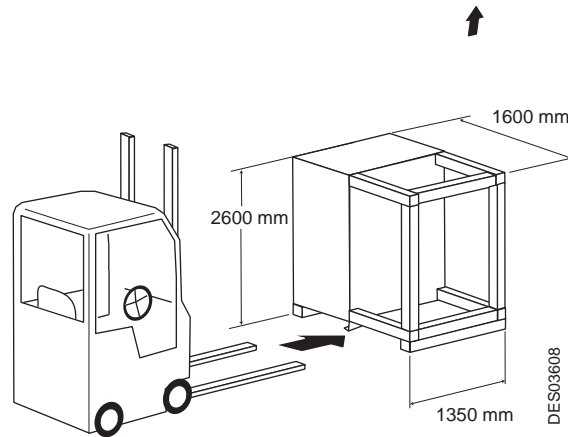

3. Commissioning and settings

3.1. Vibrator



WARNING: The setting for vibration intensity **MUST** be identical on both sides of the vibrator.

The vibrator is on the suction side of the vibrating table. The vibrator should be set to the minimum unbalance necessary to obtain a horizontal powder bed.

Preliminary setting recommended by SAMES Technologies

Setting process:

- 1 Disconnect the power supply from the vibrator.
- 2 Remove the vibrator from the vibrating table.
- 3 Remove the casings either side of the vibrator.
- 4 Unscrew the nut (B).
- 5 Adjust the unbalance on 50% value by pivoting the half-balancing weights.
- 6 Re-tighten the nut (B).
- 7 Repeat these steps to set the other side of the vibrator, making sure that it is oriented in the same way as the previous side (unbalance on same side).
- 8 Install the casings and mount the vibrator on the vibrating table.

A	Balancing weight
B	Securing nut

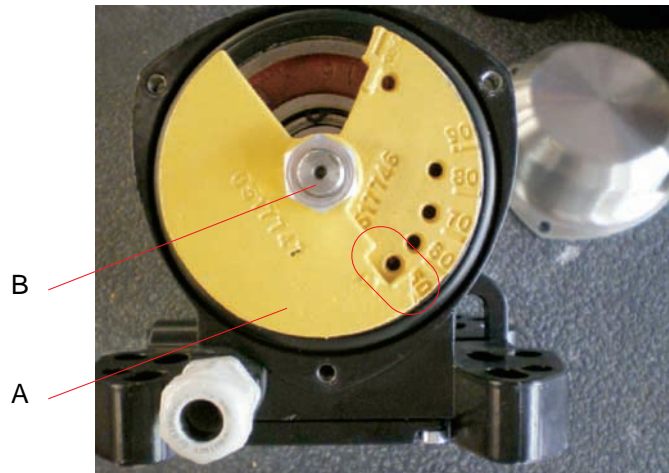

Connecting the vibrator to the ground:

The vibrator is connected to the ground by its power cable. Its metal envelope must be connected to the same ground via a green/yellow wire connected to the ground bar of the terminal box.



WARNING: The ground bar of the terminal box must be referenced at the time of the installation to the metal envelope of the powder supply unit.



3.2. Plunger cylinder restrictor

This is set by SAMES.



WARNING: Prior to starting the powder supply unit up for the first time, tighten the restrictor as far as possible so that the cylinder moves at its slowest speed.

Downwards speed: 40 mm/s (+ or - 0.5 mm/s).

Setting process:

- 1 Loosen the setting lock nut.
- 2 Tighten the restrictor screw as far as it will go.
- 3 Start up the powder supply unit.
- 4 Loosen the set screw gradually by moving the cylinder upwards and downwards until the indicated downwards speed is reached.
- 5 Re-tighten the setting lock nut.

3.3. End of stroke sensors

0	Reference position
1	High position (cylinder fully retracted) Distance (0) - (1) = 20 mm A = 467 mm
2	Unused sensor
3	Low position (if carton used) Distance (0) - (3) = 340 mm A = 52 mm
4	Low position (if tank used) Distance (0) - (4) = 340 mm A = 81 mm
5	Cleaning position Distance (0) - (5) = 420 mm Leaktight to 6 bar
6	CS 127 powder pump
7	Plunger carriage
8	Powder container

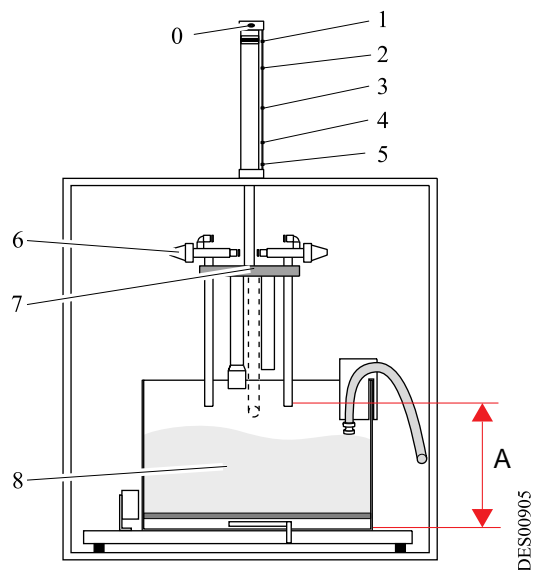

View of the powder supply unit

3.4. Powder level detector

SAMES sets this when it is first commissioned.

Setting process

- 1 Tighten the set screw located behind the detector clockwise until continuous detection is achieved away from contact with the powder. Then move a few degrees backwards anti-clockwise to halt detection.
- 2 Make sure subsequently that this setting is suitable with fluidised powder (if possible with a plugging powder).
Repeat these steps if detection is not yet continuous: away from contact with the fluidised powder, turn the set screw anti-clockwise to halt detection.
- 3 Repeat these steps until reliable detection is achieved.

3.5. Setting the ventilation

Having started up the main ventilation unit, position the "adjustment flap" (Ref. 1) to achieve an average air speed in the open section of the powder supply unit of around 0.35 m/s. The flap is then locked with a self-tapping screw.

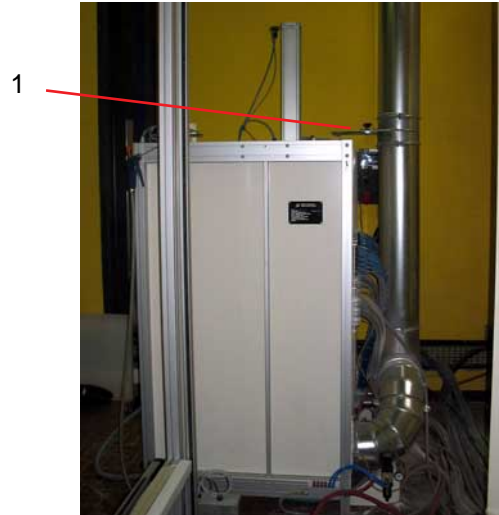

3.6. Locking the carton or tank in place

The lever (Ref. 2) is used to lock the carton or tank in place.

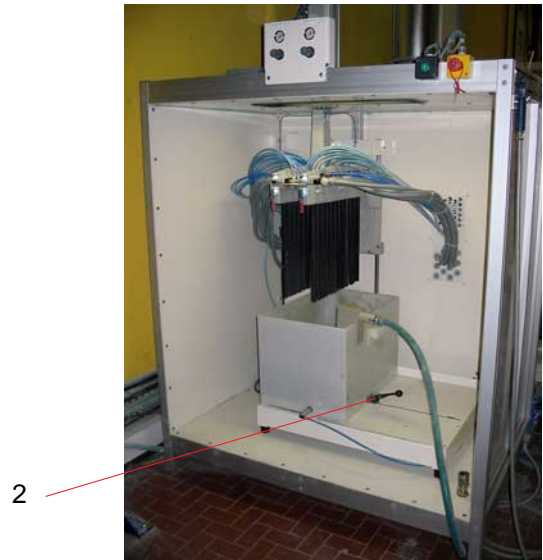

3.7. Electro-pneumatic valve supply

This is connected by SAMES.

Connect the electro-pneumatic valve supply cords to the powder supply unit's electrical cabinet (refer to the general electrical wiring diagram).

3.8. Setting the fluidisation

Two pressure release valves set and control fluidisation of the powder contained in the powder tank or carton.

Pressure release valve for carton fluidisation setting

Pressure release valve for tank fluidisation setting

Plunger carriage downwards control



3.9. Plunger carriage downwards control

A push button controls the downwards movement of the plunger carriage (see illustration above).

4. Operating procedure

Refer to the detailed functional analysis provided by the automatic control section.

5. Maintenance



WARNING: It is essential to disconnect the electrical and pneumatic supplies before any work on the powder booth.

5.1. Preventive maintenance



WARNING: Cleaning operations must be carried using only compressed air. Equipment soiling and wear caused by powder depends on the type of powder used. The servicing intervals indicated in the following table are given as an indication only.

Servicing interval	Action
Every 40 h of operation	Dismantle the CS 127 powder pumps as indicated below. Use the compressed air blower assembly to clean their various components - plunger tube, venturi ejector (removed with the extraction tool) see § 6 page 19), porous washer see RT Nr 6368
Every 40 h of operation	Check the ground connection of the carriage
Once a month	Clean the plunger carriage rails and bearings with compressed air and a rag.
Once a month	Check the rubber pins on the vibrating support when one is used. Replace them if necessary
Once a month	Check the flat seals on the distribution connectors underneath the tank bracket. Replace them if necessary

Remove and install the **CS 127** powder pumps

- Remove the container and place the plunger carriage in the midway position.
- Shut the powder supply unit down.
- Unhook the spring clips holding the **CS 127** powder pumps in place.
- Locate and disconnect the **CS 127** powder pump supply hoses.
- Remove the **CS 127** powder pumps.
- Repeat the steps in reverse order to re-install the **CS 127** powder pumps.

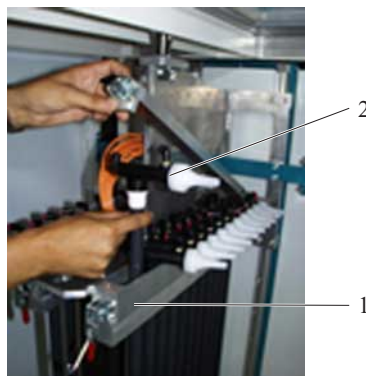

DES00908

1	Powder pump bracket
2	CS 127 powder pump

5.2. Corrective maintenance

5.2.1. Troubleshooting

Type of breakdown	Likely cause	Remedy
Insufficient air flow	Adjustment flap incorrectly positioned	Open the flap so that the average air speed in the open section of the powder supply unit is roughly equal to 0.35 m/s.
	Ventilation unit operating incorrectly	Refer to the user manual for the filtering unit
The automatic spray gun does not spray powder	Powder container empty	Replace or fill the powder container
	The powder pump is blocked	Remove the powder pump and clean it with compressed air
The plunger carriage cannot reach the high position	Too little return air pressure in the cylinder	Increase the pressure using the pressure release valve (in the cabinet)
	Guides seized	Clean and remove all traces of powder see § 5.1 page 17

Ask SAMES for the assembly/disassembly of the powder powder supply unit components before starting work on any of them: sliders, cylinder, fan.



6. Spare Parts

6.1. Vibrating table

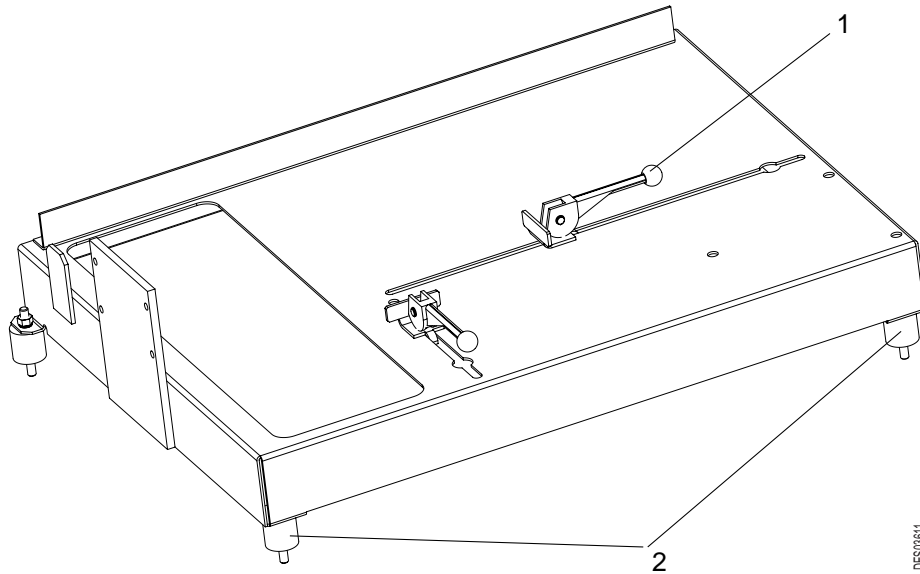

Item	Part number	Description	Qty	Unit of sale	First Emergency	Consumable
1	1313753	Carton locking lever	1	1	-	-
2	Q4BPGS054	Elastic pin	4	1	-	X

6.2. Carriage assembly

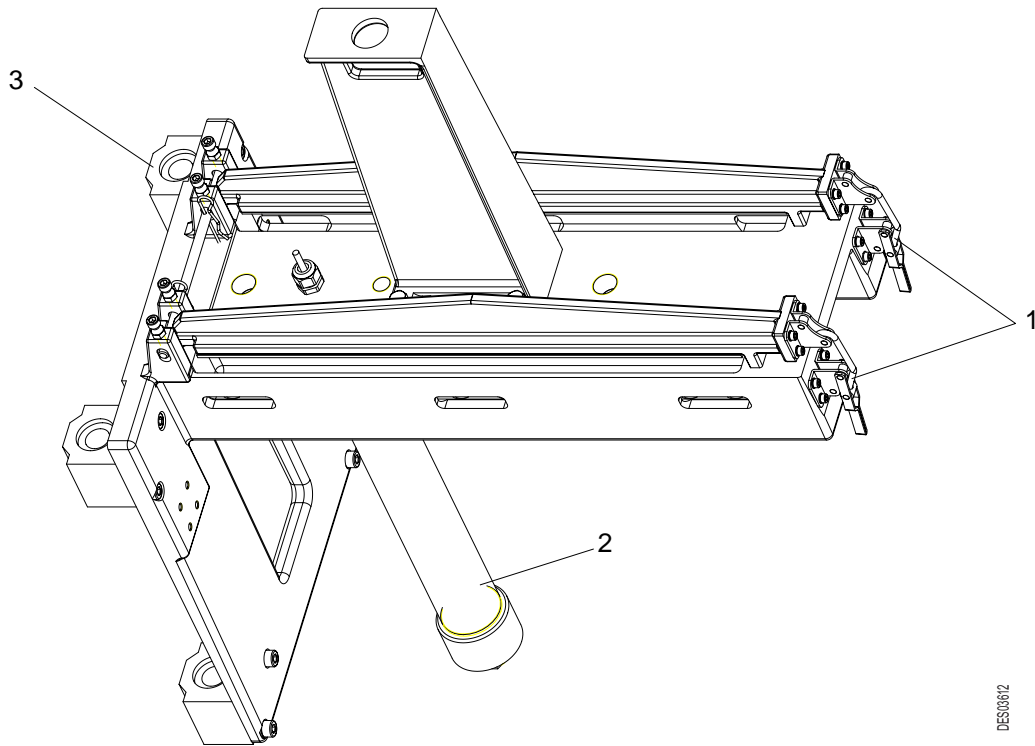

DES036/2

Item	Part number	Description	Qty	Unit of sale	First Emergency	Consumable
1	Q1FFER343	Cleat	2	1	-	-
2	110000111AT	Capacity detector	1	1	X	
3	K7ADLL059	Bearing	4	1	-	-

6.3. Powder Supply Unit

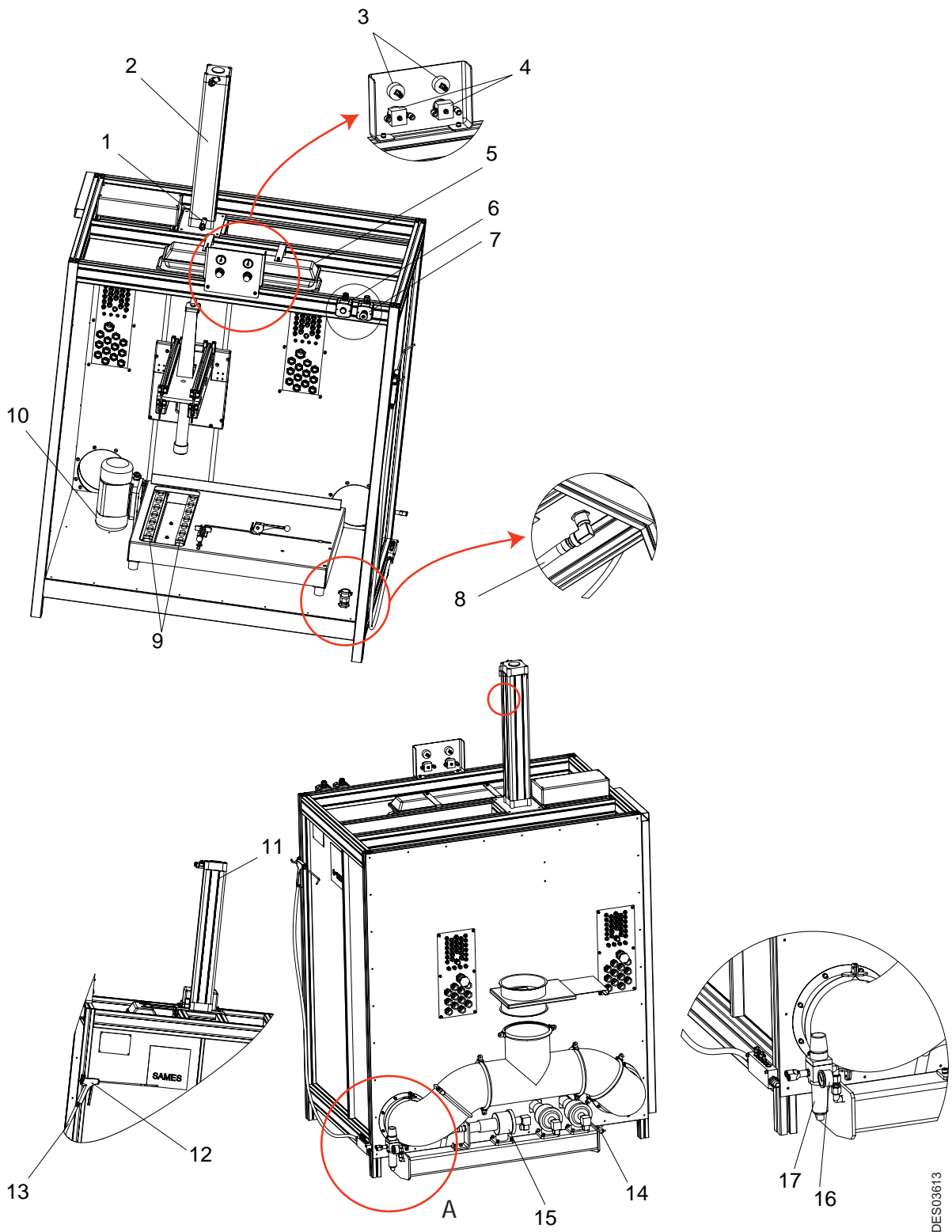

DES03613

For spare parts for the CS 127 [see RT Nr 6368](#)

Item	Part number	Description	Qty	Unit of sale	First Emergency	Consumable
1	F6RRAF095	Cylinder stop coupling	2	1	X	
2	180000027AT	Cylinder	1	1	-	X
3	R7MCAD061	Pressure gauge D: 40, 0-4 bar	2	1	-	-
4	R4DREG029	Regulator	2	1	-	-
5	E8FRST036	Light fitting	1	1	-	-
6	E3BBAB110	Push button	1	1	-	-
7	E3BBAB111	Emergency stop button	1	1	-	-
8	U1GBBA207	19/26 polyurethane hose	-	m	-	X
9	1405215	Flat seal distribution connector powder supply unit	24	1	X	X
10	180000126AT	Vibrator	2	1	-	-
11	180000016AT	Cylinder sensor	5	1	-	-
12	F3PBPU060	Blower assembly	1	1	-	-
13	F6TPVC149	14/8 clear blower assembly hose	4 m	m	-	-
14	F1SSRL020	Safety valve	1	1	-	-
15	220000003AT	Solenoid valve	3	1	X	
16	R7MCAD122	Pressure gauge D: 40, 0-10 bar	1	1	-	-
17	R4DFCM047	Filter	1	1	-	X
	1308304	Venturi removal tool	1	1	-	-