



From February 1st, 2017 SAMES Technologies SAS becomes SAMES KREMLIN SAS  
A partir du 1/02/17, SAMES Technologies SAS devient SAMES KREMLIN SAS

**SAMES**  **KREMLIN**



# User manual

## **E-SERIES** **MG 400 Manual Spray Gun** **AG 400 Automatic Spray Gun** **GCU 400 Control module**

**SAS SAMES Technologies.** 13 Chemin de Malacher -  
Inovallée - CS 70086 - 38243 Meylan Cedex France  
Tel. 33 (0)4 76 41 60 60 - Fax. 33 (0)4 76 41 60 90 - [www.sames.com](http://www.sames.com)

All communication or reproduction of this document, in any form whatsoever and all use or communication of its contents are forbidden without express written authorisation from SAMES Technologies.

The descriptions and characteristics mentioned in this document are subject to change without prior notice.

© SAMES Technologies 2010



**WARNING** : SAS Sames Technologies is registered with the Ministry of Labour as a training institution.

Throughout the year, our company offers training courses in the operation and maintenance of your equipment.

A catalogue is available on request. Choose from a wide range of courses to acquire the skills or knowledge that is required to match your production requirements and objectives.

Our training courses can be delivered at your site or in the training centre at our Meylan head office.

Training department:

Tel. 33 (0)4 76 41 60 04

E-mail: [formation-client@sames.com](mailto:formation-client@sames.com)

SAS Sames Technologies operating manuals are written in French and translated into English, German, Spanish, Italian and Portuguese.

The French version is deemed the official text and Sames will not be liable for the translations into other languages.

## E-SERIES

MG 400 Manual Spray Gun

AG 400 Automatic Spray Gun

GCU 400 Control module

1. Health and safety instructions- - - - -	4
1.1. <i>Markings on the MG 400 manual spray gun</i> . . . . .	4
1.2. <i>Markings on the AG 400 automatic spray gun</i> . . . . .	4
1.3. <i>Markings on the GCU 400 control module</i> . . . . .	4
1.4. <i>Precautions for use</i> . . . . .	5
1.5. <i>Warnings</i> . . . . .	5
2. Description - - - - -	6
2.1. <i>MG 400 and AG 400 Spray guns</i> . . . . .	6
2.2. <i>GCU 400 control module</i> . . . . .	6
3. Characteristics - - - - -	8
3.1. <i>Electric characteristics</i> . . . . .	8
4. Diagrams - - - - -	10
4.1. <i>Connecting diagram</i> . . . . .	10
4.2. <i>Pneumatic diagram</i> . . . . .	11
4.3. <i>MG 400 and AG 400 Wiring diagram, Oscillator PCB</i> . . . . .	11
5. Installation - - - - -	12
6. Operating instructions - - - - -	14
6.1. <i>DO's</i> . . . . .	16
6.2. <i>DONT's</i> . . . . .	17
6.3. <i>Changing colour</i> . . . . .	18
7. Troubleshootings - - - - -	19
8. Spare parts- - - - -	22
8.1. <i>MG 400 manual spray guns</i> . . . . .	22
8.1.1. <i>Handle assembly</i> . . . . .	23
8.1.2. <i>Option: Nozzles</i> . . . . .	24
8.2. <i>AG 400 automatic spray guns</i> . . . . .	25
8.2.1. <i>AG 400 spray gun equipped body</i> . . . . .	26
8.2.2. <i>Option: Nozzles</i> . . . . .	27
8.3. <i>Commons components to MG 400 and AG 400 spray guns</i> . . . . .	28
8.3.1. <i>Barrel assembly</i> . . . . .	28
8.3.2. <i>Nozzle extensions</i> . . . . .	29
8.4. <i>GCU 400 Control module</i> . . . . .	30
8.4.1. <i>Air Input block assembly</i> . . . . .	32
8.4.2. <i>Air output block assembly</i> . . . . .	33
8.4.3. <i>2 and 4 bar Regulators</i> . . . . .	34
8.4.4. <i>Pressure gauge assembly</i> . . . . .	35

# 1. Health and safety instructions

## 1.1. Markings on the MG 400 manual spray gun

### ATEX version

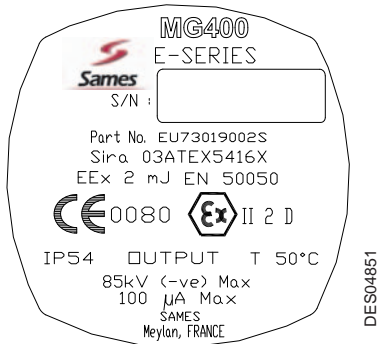

### FM Version

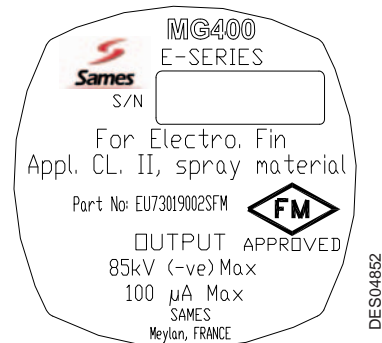

## 1.2. Markings on the AG 400 automatic spray gun

### ATEX version

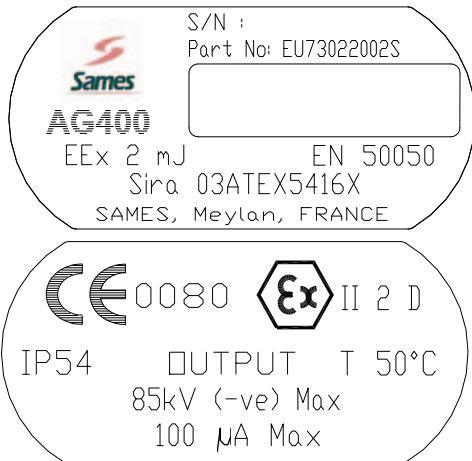

### FM Version

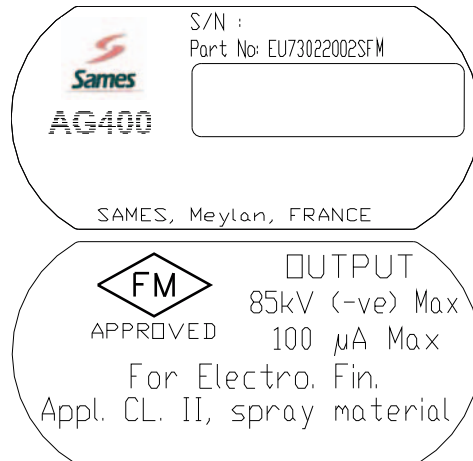

## 1.3. Markings on the GCU 400 control module

### ATEX version

 <b>WARNING</b>  <b>THIS EQUIPMENT MUST BE EARTHED</b>	<b>INPUT:-</b> 100 - 240 VAC      50/60 SINGLE PHASE 400mA AT 115V      200mA AT 230V 45 VA (FULL LOAD POWER CONSUMPTION)	<b>CE 0080</b> <b>Ex II (2) D</b> EEx 2 mJ      EN 50050 Sira 03ATEX5416X IP54      T 50°C Part No: EU72024002S S/N :
	<b>OUTPUT:-</b> 13.5VDC (MAX)      800mA (MAX) <b>GUN OUTPUT:-</b> 10 - 85kV      0 - 100µA SAMES, Meylan, France	

### FM version

 <b>WARNING</b>  <b>THIS EQUIPMENT MUST BE EARTHED</b>	<b>INPUT:-</b> 100 - 240 VAC      50/60 SINGLE PHASE 400mA AT 115V      200mA AT 230V 45 VA (FULL LOAD POWER CONSUMPTION)	GCU 400 Control Unit <b>FM</b> APPROVED *Pollution Degree 2* and *Overvoltage Category II* Part No: EU72024002SFM S/N :
	<b>OUTPUT:-</b> 13.5VDC (MAX)      800mA (MAX) <b>GUN OUTPUT:-</b> 10 - 85kV      0 - 100µA SAMES, Meylan, France	

DES04855

#### 1.4. Precautions for use

This document contains information that all operators should be aware of and understand before using these equipments. This information highlights situations that could result in serious damage and indicates the precautions that should be taken to avoid them. This equipment must only be operated by personnel trained by SAMES Technologies.

#### 1.5. Warnings



**WARNING :** This equipment may be dangerous if it is not used, disassembled and reassembled in compliance with the regulations specified in this manual and in all applicable European standards or national safety regulations.  
In countries of the EEC, refer also to EN1953:1999 and the ATEX Directive 94/9/EEC.  
For Manual Powder Spray Installations refer also to EN50053:  
Part 2:1989 and for Automatic Powder Spray Installations refer also to EN50177:1997.



**WARNING :** Equipment performance is only guaranteed if original spare parts distributed by SAMES Technologies are used.

**DO NOT permit untrained or unauthorised personnel to maintain or adjust this equipment.**

**All other manuals relevant to components and equipment of the installation must be followed.**

**NOTE: Refer to pneumatic specifications.**

- 1 Ensure that the equipment is properly earthed/grounded. Refer to assembly instructions.
- 2 The electrical supply to the gun's electrostatic generator and the control unit must be interlocked with the spray booth extraction system such that spraying cannot be carried out unless the exhaust ventilation system is in operation. The efficiency of the exhaust ventilation system should be checked regularly
- 3 All conductive structures within the vicinity of the spray area shall be bonded together with the earth terminal of the high voltage generator to the protective earth of the system electrical supply.
- 4 The equipment operates by electrostatically charging the powder by means of a high voltage corona discharge at the nozzle of the spray gun. This electrostatic discharge can seriously damage other electronic equipment if it is sited in close proximity and not suitably protected.
- 5 It is essential that all jigs and work pieces are adequately earthed. The workpiece shall have a resistance to earth of no greater than 1 Mohm. This should be checked regularly. If the earthing is not adequate, this can result in:
  - Poor coating.
  - Sparks between the product and jigs, which can constitute an ignition or explosion hazard.
  - Radio and TV interference from sparks between the product and jigs. This interference may also affect computer systems and process controllers.
- 6 Ensure the air supply is clean and dry.

## 2. Description

### 2.1. MG 400 and AG 400 Spray guns

The MG 400 and AG 400 spray guns are built to a robust and compact design using a high efficiency corona discharge to charge the powder coating material.

Both guns incorporate a high voltage unit charging system which converts the governed low voltage dc. power supply received from GCU 400 Series Gun Control Unit to a maximum output voltage of 85kV and a maximum output current of either 50uA (mode 1) or 100uA (mode 2) at the single point corona needle.

The gun nozzle may be fitted with a variety of powder deflectors and slotted caps which, combined with a forward air supply to the nozzle, enable the operator to control the spray pattern to suit the components being sprayed. A variety of nozzle adapters are available separately including extended nozzles and a cup attachment.

Both guns are manufactured with a minimum number of components and feature several mouldings offering greater reliability and ease of servicing. To this end the gun services may be disconnected within seconds.

The power connection to the gun is via a screened highly flexible cable.

The MG 400 Manual Powder Coating Spray Gun has been ergonomically designed to be well balanced, light weight and comfortable with a contoured grip.

The AG 400 Automatic Powder Coating Spray Gun may be mounted on a swivelling clamp at the end of a support arm allowing the maximum flexibility of gun position and angle with respect to the workpiece. The gun and support bar may be carried on gun manipulators such as a Reciprocator or a Swinger TM, or fitted to fixed gun mountings.

### 2.2. GCU 400 control module

The Gun Control Unit provides all the control functions necessary to spray and charge powder using the 400 Series manual and automatic powder coating spray guns.

It contains the control P.C.B. which provides a checked low voltage d.c. power supply to the spray gun. The operator may adjust the spray gun output to a maximum output voltage of 85kV and a maximum output current of either 50uA (mode 1) or 100uA (mode 2) using the control unit.

The set value of kV (mode 1) or uA (mode 2) is displayed on a numerical led display.

Separate led bar graph displays enable the operator to monitor the electrostatic charge supplied to the gun either in terms of the voltage or current. When used with manual guns the electrostatics may be turned off to enable powder emissions to be set without charging the powder.

The unit has 3 regulated pneumatic outlets, the pressure regulators and gauges being mounted on the front panel.

Two of these supply air to the venturi powder air and dilution air ports for pumping and controlling the supply of powder fed to the gun. The third is used to supply air to the nozzle of the spray gun.

Led indicators on the front panel show whether the unit is set for use with manual or automatic guns and it's also the unit is operating in mode 1 (TEC (Total Energy Control) 1) or mode 2 (TEC (Total Energy Control) 2).

The mains electrical supply to the unit is provided via. a sealed connector.

A non-switched electrical outlet is provided to enable the electrical supply to be linked through to other units, for example when situated in an automatic system console or double operator manual units.

Circuit protection is by means of miniature circuit breakers.

The unit is mounted by means of 2 x M6 screws in each side, and on the rear panel.

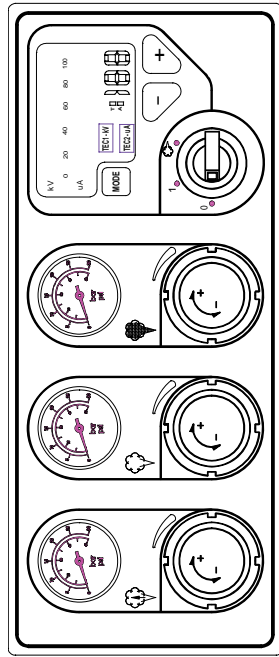

- Gun air supply
- Powder dilution air supply
- Powder delivery air supply
- UNIT OFF

- 1. UNIT ON - Powder & Electrostatics on when gun trigger switch operated
- UNIT ON - Powder without Electrostatics on when manual gun trigger switch operated and Remote control for automatic gun

Bar graph display of discharge Kilo volts

Bar graph display of discharge micro amps

Set value of electrostatic discharge - kV (TEC 1) or  $\mu$ A (TEC 2)

Illuminated when total energy control mode 1 selected operator control of kV

Illuminated when total energy control mode 2 selected operator control of  $\mu$ A

Illuminated when unit triggered by manual gun or remote PLC

Illuminated when auto gun connected

Push button selector switch for TEC 1 or TEC 2

Push button switch to reduce electrostatic output

Push button switch to increase electrostatic output

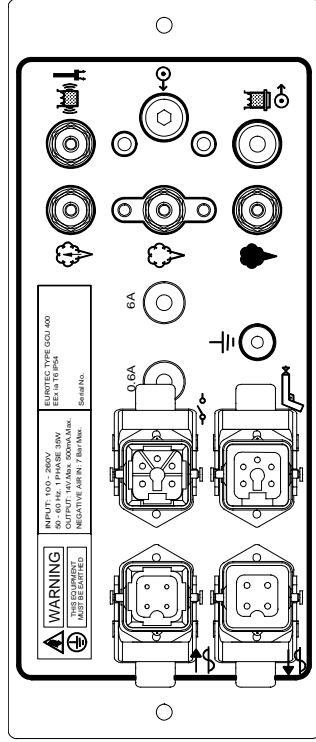

Gun air supply outlet

Powder dilution air supply outlet

Powder delivery air supply outlet

Mains electrical input (arrow points towards connector)

Mains electrical output (arrow points away connector)

Electrical output to gun

Electrical input from remote trigger

Earth connection point

Circuit breaker - generator supply

Circuit breaker - slave output

Main air supply in (arrow points towards connections)

Fluid bed / Aux air supply out

Vibrator / Fluidising pad air supply out

(arrow points away from connection)

### 3. Characteristics

#### 3.1. Electric characteristics

Electric datas	
Input Voltage	100-240 Volts 50 / 60 Hz single phase
Power Consumption (full load)	45 VA
Input Current (max.)	400 mA at 115 V 200 mA at 230 V
Electrostatic output voltage (max.)	10 - 85 kV negative
Electrostatic output current	Mode 1; 0 - 50 $\mu$ A Mode 2; 0 – 100 $\mu$ A

Electric Controls		
Mains Switch	Rotary 3 positions	OFF/ON/REMOTE (AUTO) OFF/ON/E'STATICS OFF(MANUAL)
Mode Selection	Push Button LED's display mode selected	TEC 1 (mode 1) / TEC 2 (mode 2)
Charge Control	Push Buttons +/- to increase or decrease	Sets the maximum level of kV (Mode1) Sets the maximum level of $\mu$ A (Mode2)
Set Value Display	Numerical LED Indicator	Displays set max. kV. (Mode1) TEC 1 Displays set max. uA. (Mode2) TEC 2
Electrostatic Charge Indicators	LED Bar Graphs	0 to 100 $\mu$ A / 0 to 100 kV

#### Auto-Manual Selection: GCU 400 control module automatically detects which type of gun is connected

Auto gun connected LED displays "A" Auto selected LED Indicator at "A" LED Indicator at "T" when triggered	Unit triggers automatically when main switch is turned to On position. (1) Unit triggers via remote 24V dc. supply when main switch is turned to <b>Remote position</b> 
Manual gun connected LED Indicator at "T" when triggered	Unit is triggered by micro-switch in Hand Gun or other remote triggering device when main switch is turned to On position. (1) Unit is triggered by micro-switch in Hand Gun or other remote triggering device without electrostatics when main switch is turned to <b>E'statics Off position.</b>

Mains Input	Via connector on rear panel	
Mains Output Socket	Non switched 6A max.	-may be used to connect additional control units.
Trigger Switch - Hand Gun	Microswitch in hand gun	-connected through plug and socket on rear of control unit.
Remote Trigger	24 V dc. Supply from Remote PLC	-connected through plug and socket on rear of control unit.



<b>Circuit Protection</b>		
Miniature circuit breakers	Mains input Mains output	0.6A 6A

<b>Pneumatic Data</b>	
Input air pressure	7.0 bar (102,9 p.s.i.) max
Input air conditioning	Oil free to 0.1 p.p.m. and dry to 1.3 g/cubic Nm.
Air consumption (Nominal)	400EH 10.0 cubic m/h. ( 6.0 c.f.m. ) F Bed Unit 400ED 15.0 cubic m/h. ( 9.0 c.f.m. ) Box Feed Unit 400EA 10.0 cubic m/h. ( 6.0 c.f.m. ) Auto Unit
Input connection	8mm. OD tube air fitting.

<b>Pneumatic Controls (Pressure regulators and gauge)</b>		
These control the air supply pressure to the following		
i) Powder delivery	4 bar (60 psi)	<b>venturi jet</b> controls delivery of powder from the venturi to the gun.
ii) Dilution ratio	2 bar (30 psi)	<b>venturi dilution</b> controls mixture ratio of powder to air from venturi to gun.
iii) Gun-Forward air	2 bar (30 psi)	<b>venturi dilution</b> controls mixture ratio of powder to air from venturi to gun.

<b>Weights &amp; Dimensions</b>		
Packed Unit weight/dims	40 kg	72cm x 51 cm x 106 cm
<b>Gun Control Unit GCU400</b>		
Packed Unit weight/dims	8.0 kg	280 mm x 280 mm x 120 mm
<b>Manual Gun MG 400</b>		
Packed Unit weight/dims	0,495 kg	330 mm x 200 mm x 45 mm

## 4. Diagrams

### 4.1. Connecting diagram

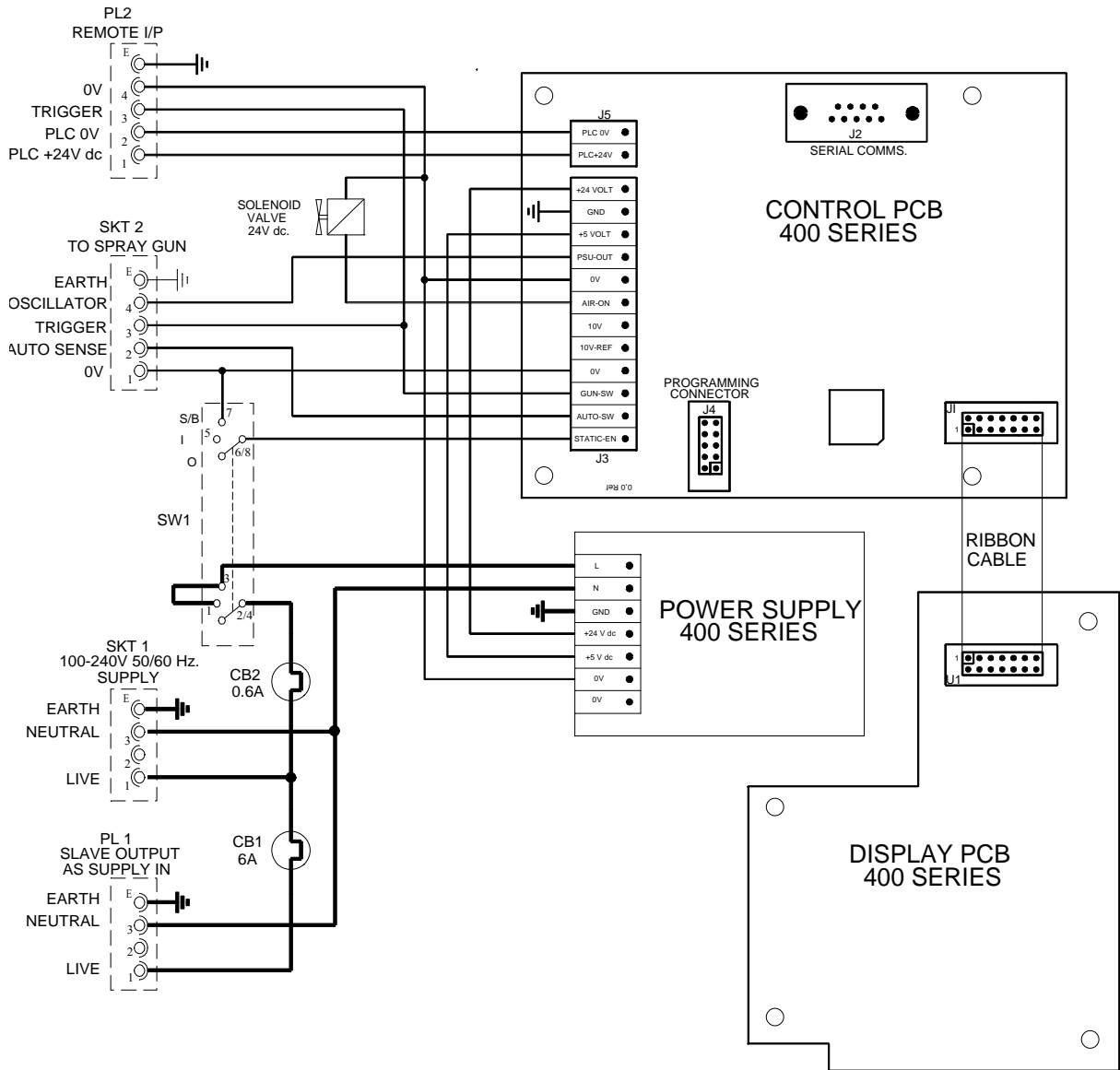

DES04944

### 4.2. Pneumatic diagram

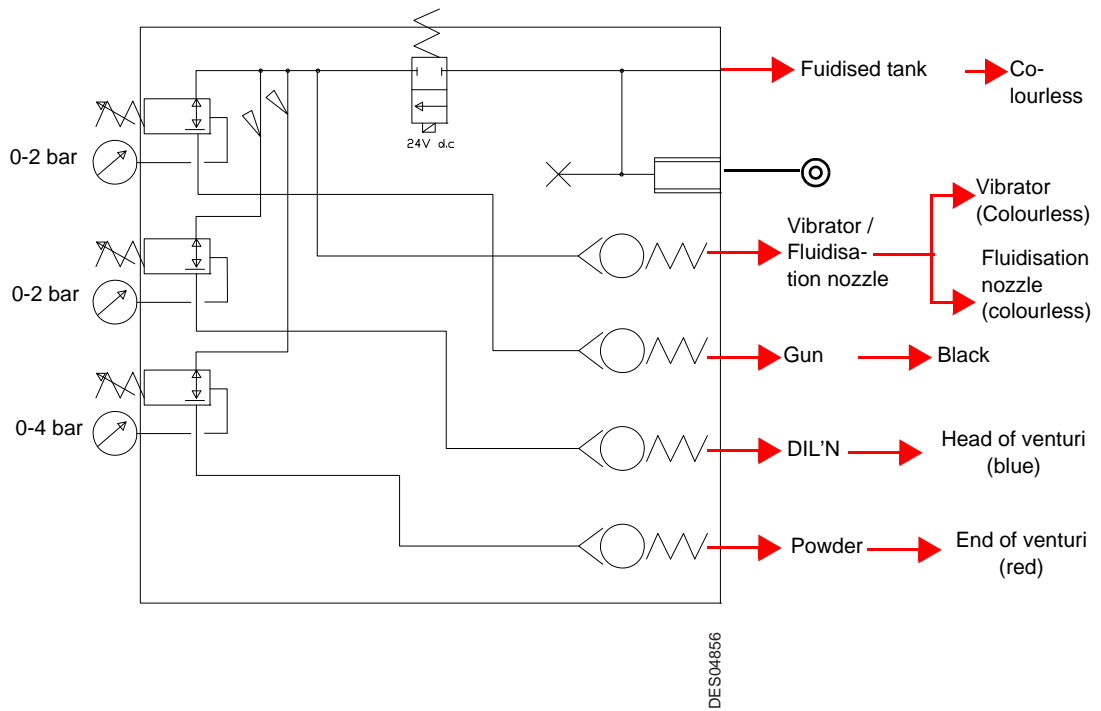

### 4.3. MG 400 and AG 400 Wiring diagram, Oscillator PCB

MG 400 manual powder gun, Oscillator PCB

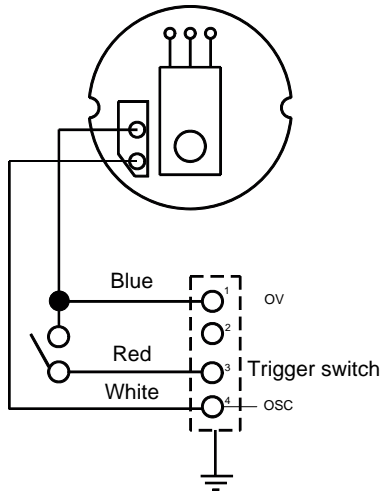

AG 400 automatic powder gun, Oscillator PCB

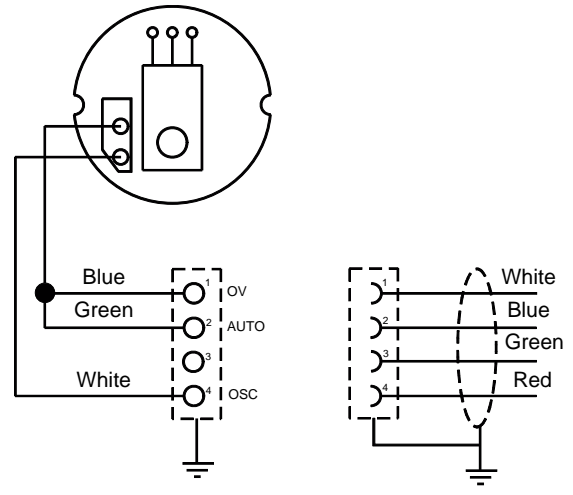

DES04843

## 5. Installation



**WARNING : This equipment must be earthed.**

- Carefully remove units and components from packaging, and check contents against packing list.
- Mount the Gun Control Unit in a secure manner. Please [see § 6.2 page 17](#) for recommended minimum installation distance of the control unit.
- Connect the airlines to the outlet ports of the rear panel of the Gun Control Unit as follows:- (Refer to the rear panel illustration and key to symbols).
  - 1 RED airline from Venturi Jet to the 'Powder Delivery Air Supply Output'.
  - 2 BLUE airline from Venturi Dilution Port to the 'Powder Dilution Air Supply Output'.
  - 3 BLACK airline from the Guns to the 'Gun Air Supply Output'.

**Fluid Bed** units, connect the CLEAR air line from the fluid bed regulator (mounted on the side of the chassis) to the 'Fluid Bed Air Supply Output' at the bottom right hand corner of the control unit.

**Box Feed** units, connect the CLEAR airlines from the vibration control regulator and the Fluidising Pad (which are joined with a "T" connector) to the 'Vibrating Box Air Supply Output' at the top right hand corner of the control unit.

NOTE: The Venturi Jet is identified by a Red washer & the Dilution Port by a Blue washer.

- Release the dust cover from the 'Gun Supply and Trigger' connector on the rear panel. Plug in and secure the gun cable using the latch provided.
- Connect a suitable airline to the main incoming air fitting, 'Mains Air Supply In'.
- Connect the mains electrical supply to the main electrical input connector.



**WARNING : When fitting a suitable plug to the mains lead, it is essential that it contains an earthing / grounding contact and that this is connected.**

**Under no circumstances should this equipment be connected to a mains supply which does not include an earthing / grounding wire and contacts. e.g.. 2 -Wire extension leads as used for some domestic equipment MUST NOT BE USED.**

The colour coding for mains wires are:

		U.K	U.S.A
Live	L	Brown	Black
Neutral	N	Blue	White
Earth/Ground	E	Green / Yellow	Green

The terminals used in the mains connectors on the rear panel of the unit are:

Live	Pin 1
Neutral	Pin 3
Earth/Ground	Pin E

### **For United Kingdom Installations**

If the colours of the mains lead of this appliance do not correspond with the coloured markings identifying the terminals in your plug, proceed as follows:

The GREEN and YELLOW wire must be connected to the terminal in the plug which is marked with the letter "E" or by the earth symbol, or coloured green or green/yellow.

The BLUE wire must be connected to the terminal which is marked with the letter "N" or coloured black.

The BROWN wire must be connected to the terminal which is marked with the letter "L" or coloured red.

**NOTE:** The method of disconnection from the mains electrical supply shall be by removal of the plug on the mains lead from its respective supply socket.

**NOTE:** If the system is intended to be permanently connected to mains wiring then the switch used to disconnect the unit from the supply voltage must disconnect all poles and have a contact separation of at least 3mm.

## 6. Operating instructions

see § 4.2 page 11 for pneumatic diagram.

- Step 1:** Ensure that all switches are in the OFF position and that all pressure regulators are closed (The knobs should be turned fully anticlockwise). The knobs of the pressure regulators are released by pulling upwards and locked by pressing inwards.
- Step 2:** If a fluidised bed is being used, this should be fully fluidised prior to spraying.
- Step 3:** With the spray gun pointing into an extracted spray booth, turn the main electrical switch to the "On" position.(1)  
 When used with automatic spray guns the mains electrical switch will also trigger the electrostatic generator and air supplies.  
 Open the left hand regulator to approx. 5 psi to supply air to the gun nozzle.  
 For a manual gun, operate the gun trigger to energise the electrostatic generator and air supplies.  
 Open the centre regulator (dilution air) to approximately 5-10 psi. and then open the right hand regulator (powder) to give the required powder output. It is good practice always to operate the "Powder" regulator last in order to avoid any powder contamination of air lines. A good starting point is approximately 20 psi.
- Step 4:** Having set the volume of powder required from the gun, there may be a tendency for the powder flow to surge unduly, this can normally be eliminated by adjusting the dilution air pressure. With the gun pointing into an extracted spray booth, trigger the unit and slowly move the nozzle of the gun progressively closer to an earth point or the product. It will be seen that as the nozzle moves closer, the current will rise progressively to a maximum of 50µA in mode 1 (TEC 1) or 100 µA in mode 2 (TEC 2). As the nozzle continues to be moved closer, the discharge current and voltage then falls progressively to very low levels as the nozzle touches the earth.

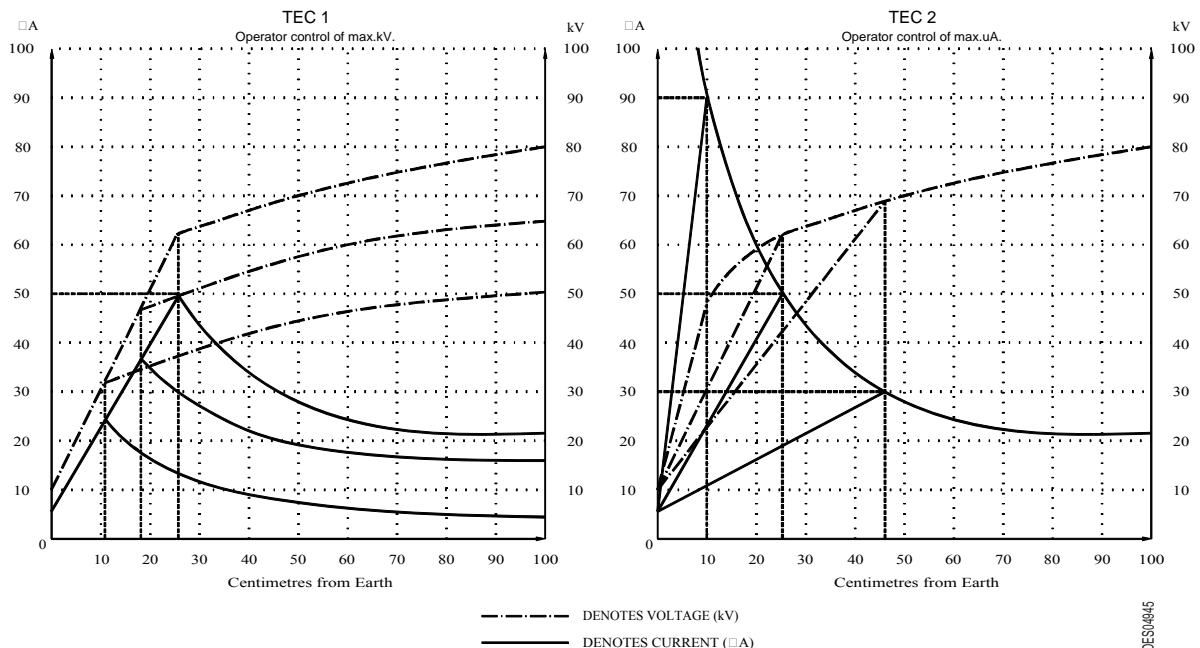

**The discharge current and voltage will be dependent on the proximity of the spray gun discharge needle to earth. When setting the maximum discharge voltage, the spray gun discharge needle should be placed at least 300 mm from earth.**

**General Observations:**

- An approved mask must always be worn when spraying.
- It is essential that all substrates and jigs are clean and that there is a good earth/ground to the workpiece to ensure maximum powder attraction.
- Powder spraying is best performed by slow motions of the spray gun as opposed to the faster gun movements often associated with liquid paint spraying.
- Higher powder emissions do not necessarily mean faster coating or better penetration into corners and recesses. In practice it can often cause the opposite effect and produce products with a poor finish.
- Similarly, high electrostatic discharge currents or voltages do not necessarily mean faster or more efficient coating. Again, in practice, they can cause the opposite effect and produce products with a poor finish.

## 6.1. DO's

- 1 Ensure that the equipment is operated by trained personnel only
- 2 Ensure that the equipment is serviced regularly by qualified personnel. All repairs and maintenance shall be carried out by qualified personnel only, in accordance with the manufacturers instructions (failure to observe may result in the invalidation of any warranty on the equipment). Repairs must be carried out at the instigation of the operator when faults or defects are detected. Repairs must not be performed in hazardous areas and must not compromise safety standards.
- 3 Ensure that the operator is correctly earthed. If overalls are worn, they should be anti-static or non-insulating. If gloves are worn, they should be anti-static or non-insulating. If this is not possible, gloves with the palms removed may be used. Footwear intended for use by operators shall be anti-static or non-insulating and shall comply with the requirements of ISO 2251 / BS 5451 or equivalent. Shoes with leather soles are usually adequate.
- 4 Ensure that the operator wears suitable respiratory equipment and or protective clothing. All personnel working in a powder-laden atmosphere should wear similar equipment.
- 5 Ensure that the operator wears suitable eye protection e.g. goggles or visor (in addition to a respiratory mask) when using a compressed air clean down gun as particles in the airstream can damage eyes.
- 6 Avoid skin contact with powders where possible as some powders may cause skin irritation.
- 7 Wash hands and face after work and prior to eating or drinking.
- 8 Keep floors and equipment within 5 metres of the spray area clean using a suitable industrial vacuum cleaner.
- 9 Keep light fittings and all other electrical equipment clean.
- 10 Regularly check the effectiveness of dust/powder extraction filters and that recycled air is clean.
- 11 Regularly check the earthing of electrical equipment and manually operated spray guns.
- 12 Regularly check the earth bonding of all conductive electrical enclosures and all conductive structures such as floors, walls, ceilings, fences, conveyors, powder containers etc. within the vicinity of the spray area. These shall be bonded together with the earth terminal of the high voltage generator to the protective earth system of the electrical supply. Electrostatic grounding should comply with EN 50053.
- 13 Ensure that all jigs and work pieces are adequately earthed. Each workpiece shall have a resistance to earth of not greater than 1 Mohm. This resistance shall be checked regularly.
- 14 Ensure that correct cleaning procedures are followed ([see § 6.3 page 18](#)).
- 15 Ensure that powders are processed in compliance with the powder manufacturers instructions. Special care should be taken with powders containing metallic pigments.



**WARNING :** The workplace must be kept tidy and well organized to reduce the risk of accidents. Good illumination, protection from any damp environment and correct storage of materials will assist the operator to maintain concentration and an awareness of potential hazards.



**WARNING :** Before starting to clean the spray gun or carrying out any other work in the spraying area, the high voltage supply shall be switched off in such a manner that it cannot be re-energized by operating the trigger of the spray gun.



## 6.2. DONT's

- 1 The operator must not wear insulating gloves, clothing or footwear.
- 2 Do not smoke in areas where powder coating is being carried out or in areas where powder is stored.
- 3 Do not eat or drink in areas where powder coating is being carried out or in dust-laden atmospheres.
- 4 Do not spray into areas which are not properly extracted. The direction of airflow should always be from behind the operator. It is recommended that airflow velocities over the face area of a booth opening should be in excess of 0.5 metre/sec.
- 5 Do not use compressed air for cleaning skin and clothing as it can penetrate the skin causing embolisms. Use a suitable industrial vacuum cleaner for clothing and wash skin with water.
- 6 Do not point compressed air clean down guns towards body orifices such as mouth, ears etc.
- 7 Do not enter spray booths when in operation.
- 8 Do not operate fluidized beds without connecting a suitable vent hose from its lid to an extracted area such as a spray booth.
- 9 Do not place the GCU control within the minimum specified distance shown below.

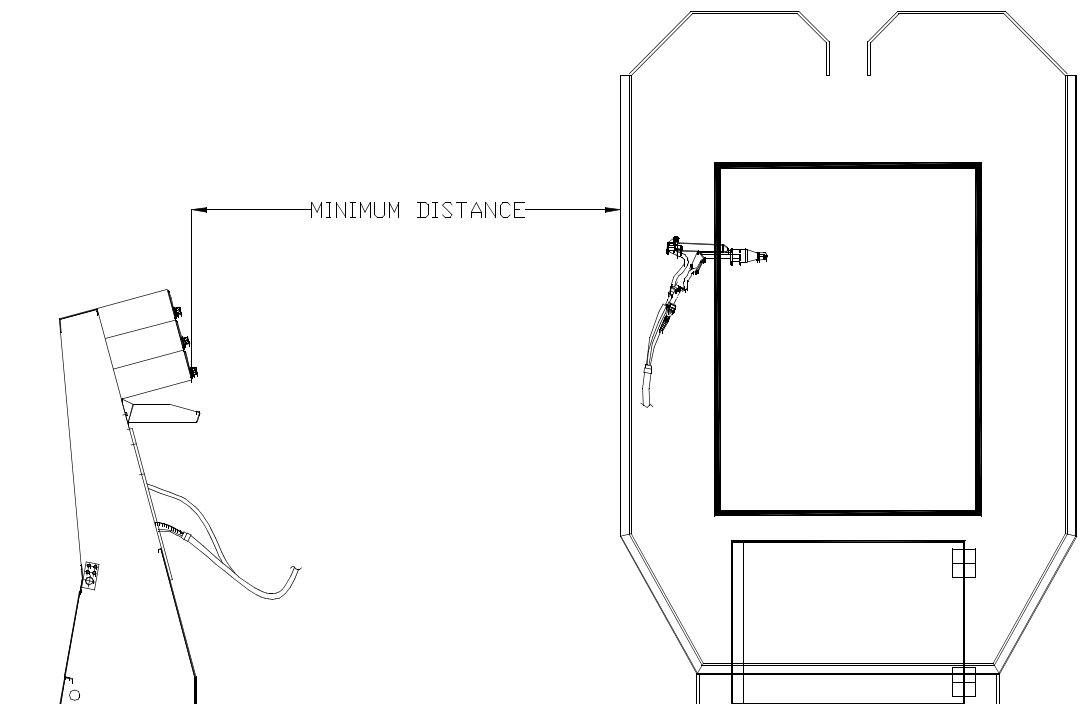

**When installing the control unit make sure the minimum distance from the control unit to any spray booth opening is 1.5 m:**

**The control unit is not permitted inside the hazardous area. Only the Manual gun unit and the Automatic gun unit are designed for Class II, Division 1 area.**

### 6.3. Changing colour

In order to prevent contamination of the product from a previous colour, it is essential to remove all traces of the previously sprayed powder from the application equipment. i.e.. Powder container, suction tubes, Venturies, Powder hoses and Spray guns. Also any other surfaces where powder may become dislodged and cause contamination of the product or new powder. If the powder is to be reclaimed, then the spray booth, ductwork and recovery equipment must also be thoroughly cleaned.



**WARNING : Whenever compressed air is used for cleaning equipment. This operation must be carried out in an extracted spraybooth.**

- 1 Turn the mains switch OFF, discharge the gun by touching the corona needle to a good earth and disconnect the mains supply.
- 2 Remove the venturi.
- 3 Remove the powder hose and airlines from the venturi.
- 4 Squeeze the oval clip at the top of the suction tube and remove the suction tube from the venturi mounting spigot. Remove any excess powder from the venturi mounting bracket (box feed) or fluid bed lid.
- 5 Using clean, dry compressed air from a blow gun, blow through the suction tube and wipe clean the outside.
- 6 Remove the powder box or clean the fluid bed.
- 7 Remove the powder tail fitting complete with the PTFE insert from the venturi body and blow them clean.
- 8 Blow through the venturi body and clean the outside then refit the hose tail and insert. ALWAYS CHECK THE CONDITION OF THE PTFE INSERT FOR SIGNS OF EXCESSIVE WEAR AND REPLACE AS NECESSARY.
- 9 Remove the powder hose from the gun and purge the inside of the hose with compressed air from both ends ensuring that the discharge end is pointing into an extracted spray booth.
- 10 Remove the nozzle from the gun and clean internally and externally with compressed air. Clean the gun in the same way.
- 11 Refit the nozzle and powder hose to the gun.
- 12 Replace the suction tube into the venturi mounting spigot such that it clips into place and is retained by the oval clip.
- 13 Re-connect the powder hose to the venturi, and the airlines i.e. red airline to fitting with red washer and blue airline to fitting with blue washer, then clip the venturi back on to the spigot.
- 14 Clean off any excess powder or contamination from chassis (manual units).

## 7. Troubleshootings

Symptoms	Remedies
<p>The check unit GCU 400 will not operate (No LED's will illuminate)</p>	<p>Check that mains connector is fitted to rear panel of control module</p>
	<p>Check that module is connected to a suitable mains electrical supply and is switched on (the electrical supply should be interlocked with the booth extraction system)</p>
	<p>Check that miniature circuit breaker (automatic fuses) on the rear panel of the control unit have not been tripped. If one or more has, then press to reset. If it trips again, switch off unit and refer to an authorized distributor or service agent.</p>
<p>The check unit GCU 400 will not operate (LED's will illuminate)</p>	<p>Check the gun trigger connection on the rear panel of the control unit is correctly fitted</p>
	<p>Check the gun trigger connection on the bottom of the gun handle is correctly fitted.</p>
	<p>Check that the trigger switch in the gun is operating. Depress the trigger and an audible click should be heard if the trigger switch is operating. LED at "T".</p>

No powder delivery	Check air supply to unit.
	Check that the powder container is not empty .
	Check that the powder in the powder container has no rat holes or voids around the suction or induction point - increase fluidization / vibration or agitate powder cup Check that powder is not damp.
	Check for kinked or blocked powder hose.
	Check for blockage in suction tube, venturi body and gun.
	Check that the internal solenoid valve is operating by depressing gun trigger when an audible click should be heard from inside the control unit. If it is not, check the gun trigger connection on the rear panel of the control unit and the bottom of the gun.
Powder delivery (intermittent or surging)	Check ratio of dilution air to powder air and adjust if necessary.
	Check for any kinks or partial blockages in the powder hose, venturi suction tube and body, or gun.
	Check that the venturi body is seating firmly on the mounting spigot and that o-rings are not damaged.
	Check condition of the PTFE insert in the venturi for signs of wear-replace as necessary.
	Check that there is sufficient powder in the box
	Check that the induction holes in the bottom of the suction tube are fully immersed in the box.
Powder does not adhere to workpiece	Manual gun: check that main switch is set to I (on) and not the second position which turns off the electrostatics
	Check that the setting of the charge control (kV et $\mu$ A). and that an electrostatic charge is present at the discharge electrode needle of the gun.
	If no charge (or very poor charge) is present, then check that there is no water present from the compressed air supply or from condensation.
	Check that the gun barrel is not contaminated with metallic particles from bright unbonded metallic powders.
	Check that the workpiece is properly earthed/grounded.

## Defaults on finished product

Symptoms	Remedies
Contamination of surface with specks of other colours	Application equipment inadequately cleaned after using previous powder.
	Airborne powder of different type within a contaminated spray booth, or sucked in from dirty surroundings.
	Reclaimed powder contaminated within other powders from within the reclaim system e.g. ductwork, cyclone, booth etc...
	Airborne contamination within the oven.
	Dust or dirt dislodged from jigs or conveyor.
	Dusty environment before or after coating.
Lumps or protrusions on surface	Dirty or contaminated powder
	Dirty or contaminated substrate (workpiece)
	Rusty substrate
	Dusty environment before or after coating.
	Dust or dirt in oven
	Dust or dirt dislodged from jigs or conveyor.
Heavy "orange peel"	Applied coating is too thick
	Incorrect cure cycle and/or temperature
	Inferior quality of powder
Fish eyes	Contamination of substrate
	Contamination of powder
	Contamination of compressed air supply e.g. Silicone
Craters and voids	Poor cleaning of substrate e.g. trapped oils or solvents
	Wet components e.g. water trapped in corners or joints
	Contamination of powder
	Contamination of substrate
Pin- holing and bubbles	Porous substrate e.g. expansion or air or solvents from porosity or cavities in castings during curing cycle. Pre-heating of the workpiece may help.
	Excessive electrostatic charge applied to the powder. To overcome, reduce the discharge voltage and/or increase the spraying distance
	Rusty substrate
	Contamination of substrate, powder, air supply or from dirty surroundings.
	Excessive moisture in compressed air supply ( <a href="#">see § 3 page 8</a> )

**Note 1: Contamination may be caused by airborne vapour such as wet paint, airline or conveyor oil or stripping facilities.**

**Note 2: Silicones and acrylic paints are the worst offenders and can contaminate the powder and / or substrate.**

## 8. Spare parts

### 8.1. MG 400 manual spray guns

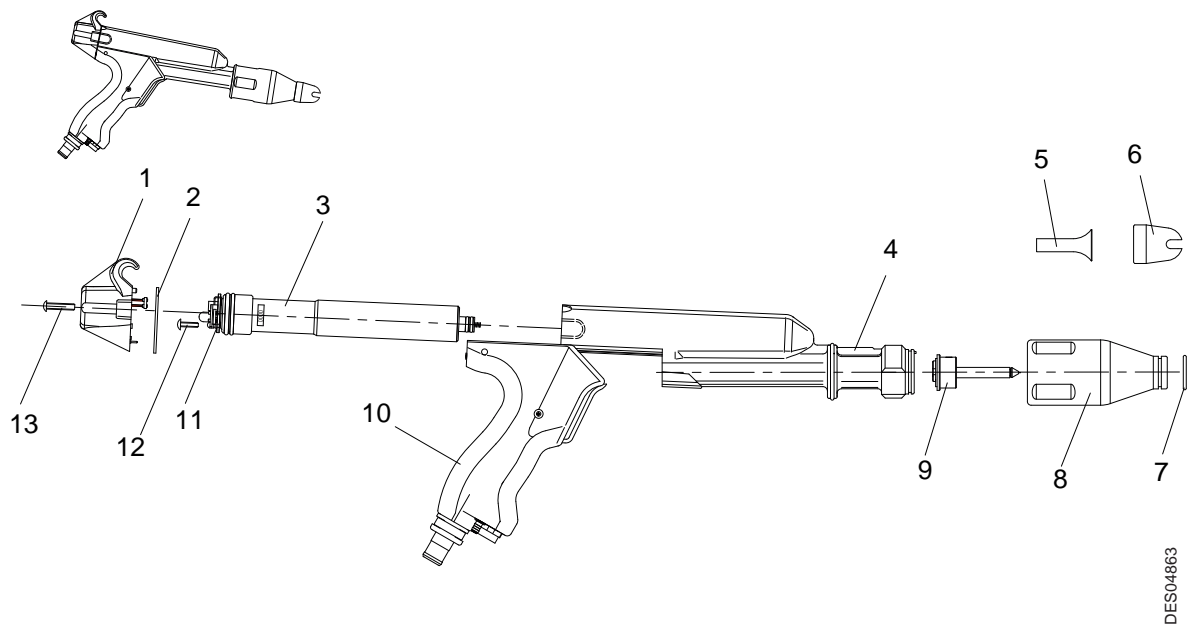

Item	Part Number	Description	Qty	Sale Unit	Level for spare part (*)
	<b>EU73019002S</b>	<b>MG 400 manual spray gun, Version Atex</b>	<b>1</b>	<b>1</b>	<b>3</b>
	<b>EU73019002SFM</b>	<b>MG 400 manual spray gun, Version FM</b>	<b>1</b>	<b>1</b>	<b>3</b>
1	EU73019006	Rear cap	1	1	3
2	EU3019020	Flat seal of rear cap	1	1	1
3	EU73019007	High voltage cascade	1	1	3
4	<b>EU73019005S</b>	<b>Barrel assembly</b> ( <a href="#">see § 8.3.1 page 28</a> )	<b>1</b>	<b>1</b>	<b>3</b>
5	EU3016201	Round spray nozzle, medium	1	1	1
6	EU3019017	6mm fan spray nozzle, black	1	1	1
7	EU9001856	Red o-ring	1	1	1
8	EU3019013	Nozzle nut	1	1	3
9	EU73016185	Electrode assembly	1	1	1
10	<b>EU73019004S</b>	<b>Handle assembly</b> ( <a href="#">see § 8.1.1 page 23</a> )	<b>1</b>	<b>1</b>	<b>3</b>
11	EU73019008	Oscillator	1	1	3
12	EU9000511	M3 x 12 screw	1	1	3
13	EU9000578	M4 x 20 screw	2	1	3

(\*)

**Level 1: Standard preventive maintenance**

**Level 2: Corrective maintenance**

**Level 3: Exceptional maintenance**

### 8.1.1. Handle assembly

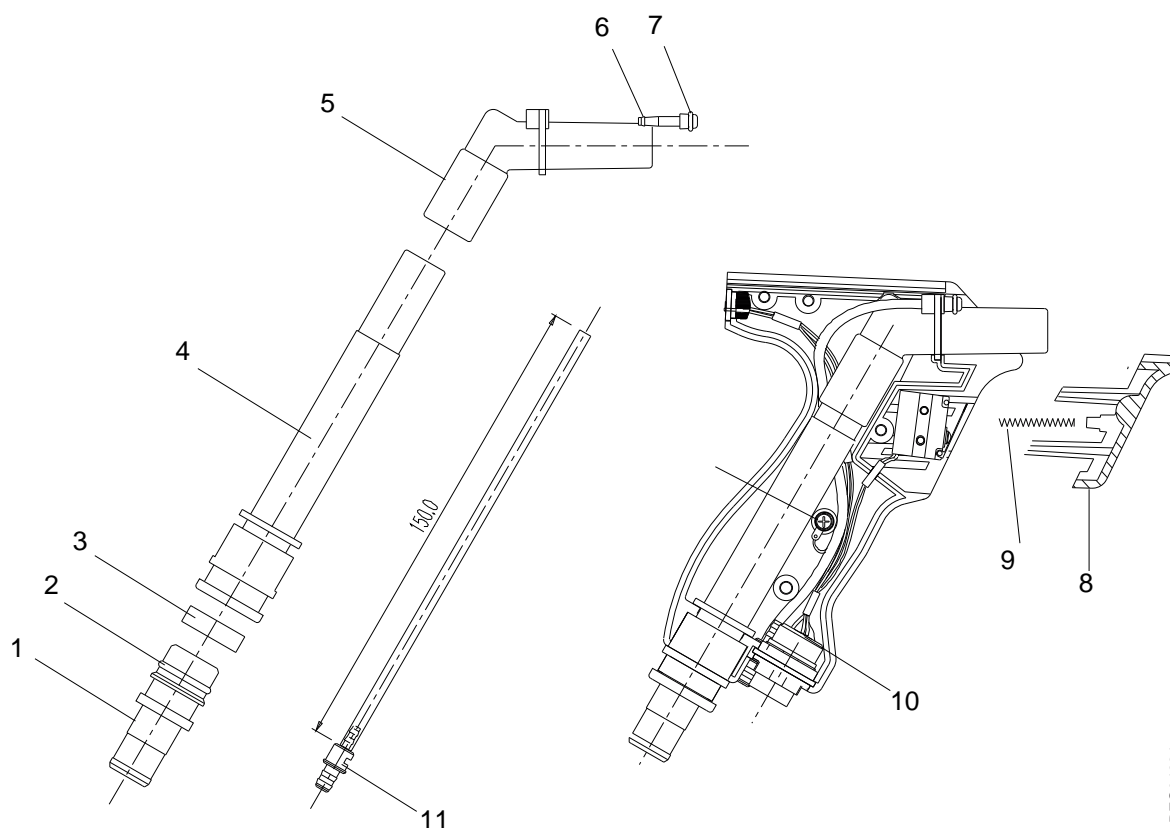

DES04864

Item	Part Number	Description	Qty	Sale Unit	Level for spare part (*)
	<b>EU73019004S</b>	<b>Handle assembly</b>	<b>1</b>	<b>1</b>	<b>3</b>
1	EU3019025	End piece of powder tube	1	1	2
2	EU9001863	Black o-ring	1	1	1
3	EU3019026	Locking ring of powder tube	1	1	1
4	EU3019024	Powder tube	1	1	2
5	EU3019011	Elbow	1	1	2
6	EU3019027	Air pipette	1	1	1
7	EU9001860	Black o-ring	1	1	1
8	EU3019012S	Red trigger	1	1	3
9	EU9001853	Trigger spring	2	1	2
10	EU73019009	Electric connection assembly	1	1	3
11	EU3019028	Air connector	1	1	2

(\*)

**Level 1: Standard preventive maintenance**

**Level 2: Corrective maintenance**

**Level 3: Exceptional maintenance**

8.1.2. Option: Nozzles

Item	Part Number	Description	Qty	Sale Unit	Level for spare part (*)
	EU3016200	Round spray nozzle, small	Option	1	1
	EU3016202	Round spray nozzle, large	Option	1	1
	EU3022019	4mm fan spray nozzle, black	Option	1	1

(\*)

**Level 1: Standard preventive maintenance**

**Level 2: Corrective maintenance**

**Level 3: Exceptional maintenance**



## 8.2. AG 400 automatic spray guns

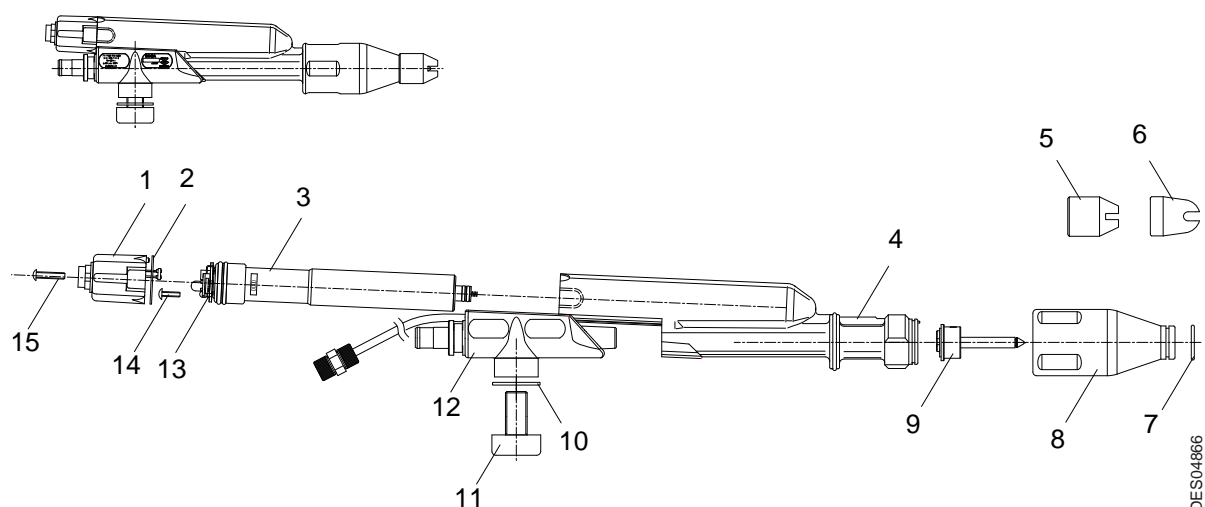

Item	Part Number	Description	Qty	Sale Unit	Level for spare part (*)
	<b>EU73022002S</b>	<b>AG 400 spray gun, version Atex</b>	<b>1</b>	<b>1</b>	<b>3</b>
	<b>EU73022002SFM</b>	<b>AG 400 spray gun, version FM</b>	<b>1</b>	<b>1</b>	<b>3</b>
1	EU73022006	Equipped rear cap	1	1	3
2	900006359	Rear cap o-ring	1	1	1
3	EU73019007	High voltage cascade	1	1	3
4	<b>EU73019005S</b>	<b>Barrel assembly (see § 8.3.1 page 28)</b>	<b>1</b>	<b>1</b>	<b>3</b>
5	EU3022019	4mm fan spray nozzle, black	1	1	1
6	EU3019017	6mm fan spray nozzle, black	1	1	1
7	EU9001856	Red o-ring	1	1	1
8	EU3019013	Nozzle nut	1	1	3
9	EU73016185	Electrode assembly	1	1	1
10	EU3001014	Gun clamp washer	1	1	3
11	EU3001012	Gun clamp screw	1	1	3
12	<b>EU73022004</b>	<b>Equipped body (see § 8.2.1 page 26)</b>	<b>1</b>	<b>1</b>	<b>3</b>
13	EU73019008	Oscillator	1	1	3
14	EU9000511	Screw, M3 x 12	1	1	3
15	250000185	Screw, M4 x 20 glass fiber nylon	2	1	1

(\*)

**Level 1: Standard preventive maintenance**

**Level 2: Corrective maintenance**

**Level 3: Exceptional maintenance**

### 8.2.1. AG 400 spray gun equipped body

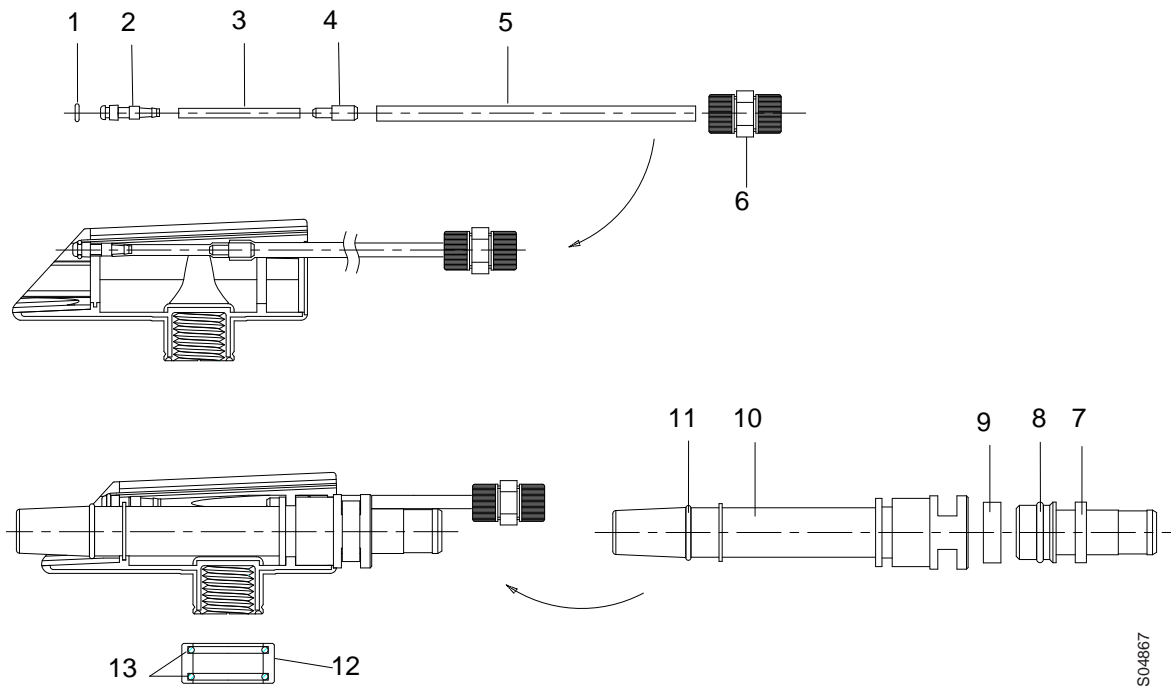

DES04867

Item	Part Number	Description	Qty	Sale Unit	Level for spare part (*)
	<b>EU73022004</b>	<b>AG 400 spray gun equipped body</b>	<b>1</b>	<b>1</b>	<b>3</b>
1	EU9001860	Black o-ring	1	1	1
2	EU3019027	Air pipette	1	1	1
3	EU9000203	Black hose Dia: 4	0.04	m	2
4	EU3022015	Air connection pipette	1	1	1
5	EU9000084	Black hose Dia: 6	0.1	m	2
6	EU9000116	Female-female dual fitting	1	1	3
7	EU3019025	End piece of powder tube	1	1	2
8	EU9001863	Black o-ring	1	1	2
9	EU3019026	Locking ring of powder tube	1	1	1
10	EU3022013	Powder tube	1	1	2
11	EU9001862	Black o-ring	1	1	2
12	EU3022016	Clip ring	1	1	2
13	EU9001881	Black o-ring	2	1	2

(\*)

**Level 1: Standard preventive maintenance**

**Level 2: Corrective maintenance**

**Level 3: Exceptional maintenance**

8.2.2. Option: Nozzles

Item	Part Number	Description	Qty	Sale Unit	Level for spare part (*)
	EU3016200	Round spray nozzle, small	Option	1	1
	EU3016201	Round spray nozzle, medium	Option	1	1
	EU3016202	Round spray nozzle, large	Option	1	1

(\*)

**Level 1: Standard preventive maintenance**

**Level 2: Corrective maintenance**

**Level 3: Exceptional maintenance**

### 8.3. Commons components to MG 400 and AG 400 spray guns

#### 8.3.1. Barrel assembly

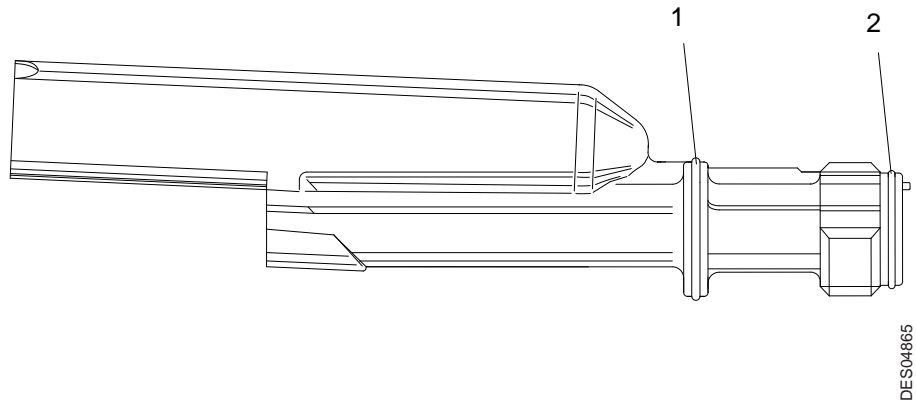

DES04865

Item	Part Number	Description	Qty	Sale Unit	Level for spare part (*)
	<b>EU73019005S</b>	<b>Barrel assembly</b>	<b>1</b>	<b>1</b>	<b>3</b>
1	EU9001917	Red o-ring	1	1	1
2	EU9001865	Red o-ring	1	1	1

(\*)

**Level 1: Standard preventive maintenance**

**Level 2: Corrective maintenance**

**Level 3: Exceptional maintenance**

### 8.3.2. Nozzle extensions

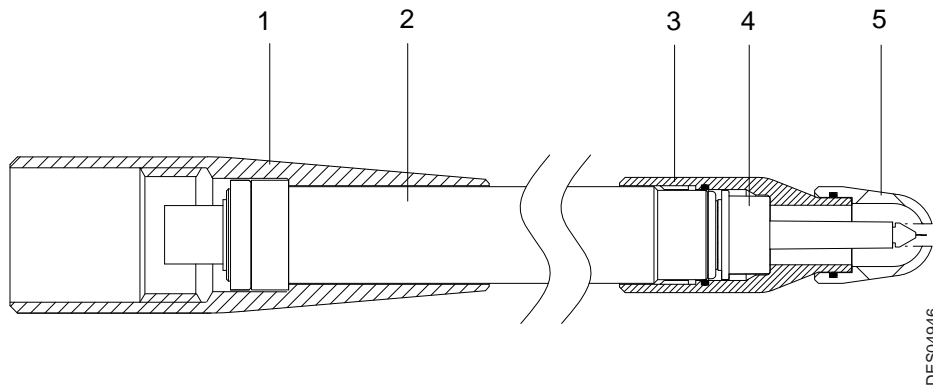

Item	Part Number	Description	Qty	Sale Unit	Level for spare part (*)
	EU73019190	Nozzle extension, length 200 mm	Option	1	3
	EU73019191	Nozzle extension, length 300 mm	Option	1	3
	EU73019192	Nozzle extension, length 600 mm	Option	1	3
1	EU3019035	Nozzle nut	1	1	3
2	EU73016195	Nozzle extension body, length 200 mm	1	1	3
	EU73016196	Nozzle extension body, length 300 mm	1	1	3
	EU73016197	Nozzle extension body, length 600 mm	1	1	3
3	EU73016169	Nozzle front assembly	1	1	3
4	EU73016185	Electrode assembly	1	1	1
5	EU73016187	Nozzle assembly	1	1	1

(\*)

**Level 1: Standard preventive maintenance**

**Level 2: Corrective maintenance**

**Level 3: Exceptional maintenance**

### 8.4. GCU 400 Control module

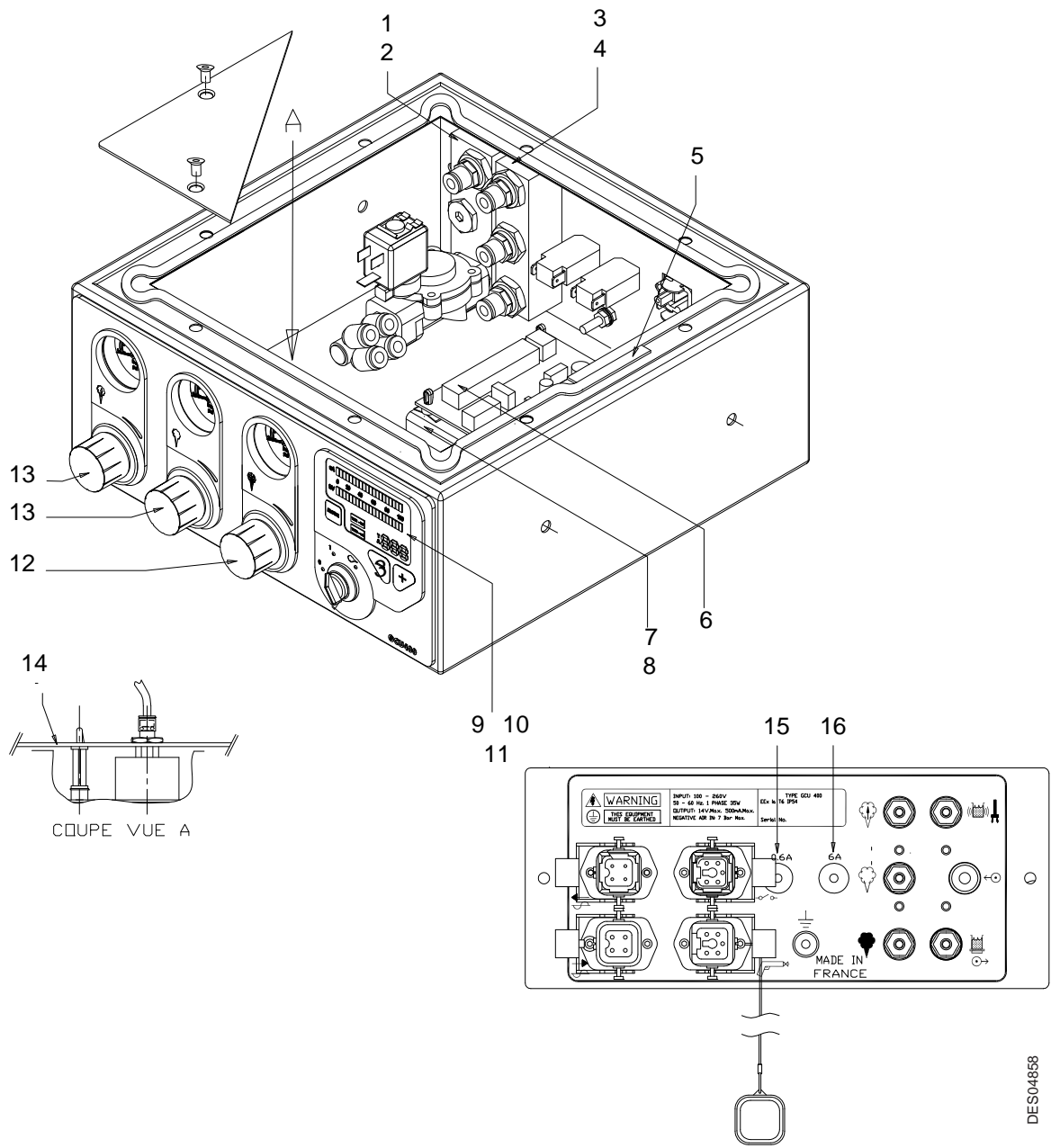

DES04858

Item	Part Number	Description	Qty	Sale Unit	Level for spare part (*)
	<b>EU72024002S</b>	<b>GCU 400 Module version ATEX</b>	<b>1</b>	<b>1</b>	<b>3</b>
	<b>EU72024002SFM</b>	<b>GCU 400 Module version FM</b>	<b>1</b>	<b>1</b>	<b>3</b>
<b>1</b>	<b>EU72024009</b>	<b>Air input block assembly</b> (see § 8.4.1 page 32)	<b>1</b>	<b>1</b>	<b>3</b>
2	EU2020060	Flat seal, air input block assembly	1	1	2
<b>3</b>	<b>EU72024021</b>	<b>Air output block assembly</b> (see § 8.4.2 page 33)	<b>1</b>	<b>1</b>	<b>3</b>
4	EU2020061	Flat seal, air output block assembly	1	1	2
5	EU9000063	Self-adhesive foam seal	1	1	3
6	EU2024006	Control PCB	1	1	3
7	EU9001882	Supply block	1	1	3
8	EU9001847	Plastic pillar 6.4 mm	4	1	3
9	EU2024005	Display PCB	1	1	3
10	EU9001849	Plastic pillar 9.5 mm	3	1	3
11	EU9001898	Nut M4 plastic	3	1	3
<b>12</b>	<b>EU72010018</b>	<b>Regulator assembly 4 bar</b> (see § 8.4.3 page 34)	<b>1</b>	<b>1</b>	<b>3</b>
<b>13</b>	<b>EU72000026</b>	<b>Regulator assembly 2 bar</b> (see § 8.4.3 page 34)	<b>2</b>	<b>1</b>	<b>3</b>
<b>14</b>	<b>910009000</b>	<b>Pressure gauge assembly</b> (see § 8.4.4 page 35)	<b>1</b>	<b>1</b>	<b>3</b>
15	EU9000016	Circuit breaker 0,6A	1	1	3
16	EU9000018	Circuit breaker 6A	1	1	3

(\*)

**Level 1: Standard preventive maintenance**

**Level 2: Corrective maintenance**

**Level 3: Exceptional maintenance**

### 8.4.1. Air Input block assembly

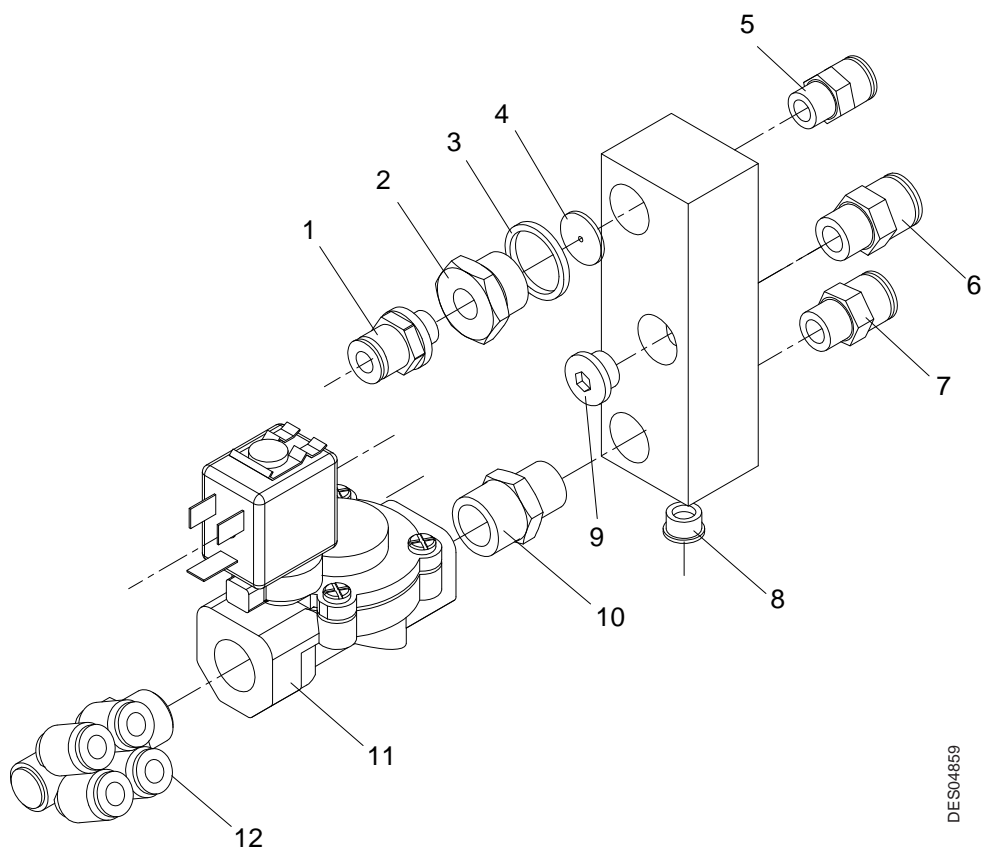

Item	Part Number	Description	Qty	Sale Unit	Level for spare part (*)
	<b>EU72024009</b>	<b>Air input block assembly</b>	<b>1</b>	<b>1</b>	<b>3</b>
1	EU9000041	Straight fitting 1/8BSPM Dia: 6 plastic	1	1	2
2	EU2000031	Valve, Non return	1	1	3
3	EU9000042	Washer 3/8BSP	1	1	2
4	EU2000037	Seal, non return valve	1	1	2
5	EU9001889	Straight fitting 1/8BSPMT Dia: 6 metal	1	1	3
6	EU9001891	Straight fitting 1/4BSPMT Dia: 8 metal	1	1	3
7	EU9001890	Straight fitting 1/4BSPMT Dia: 6 metal	1	1	3
8	EU9001874	Plug 1/8 BSPMP	1	1	3
9	EU9001880	Plug 1/4 BSPMP	1	1	3
10	EU9000032	Male-male fitting 1/4 BSPMT 3/8BSPMT	1	1	3
11	EU9000038	Solenoid valve 2/2 3/8 BSP 24V DC	1	1	2
12	EU9001746	Banjo 3/8	1	1	3

(\*)

**Level 1: Standard preventive maintenance**

**Level 2: Corrective maintenance**

**Level 3: Exceptional maintenance**



#### 8.4.2. Air output block assembly

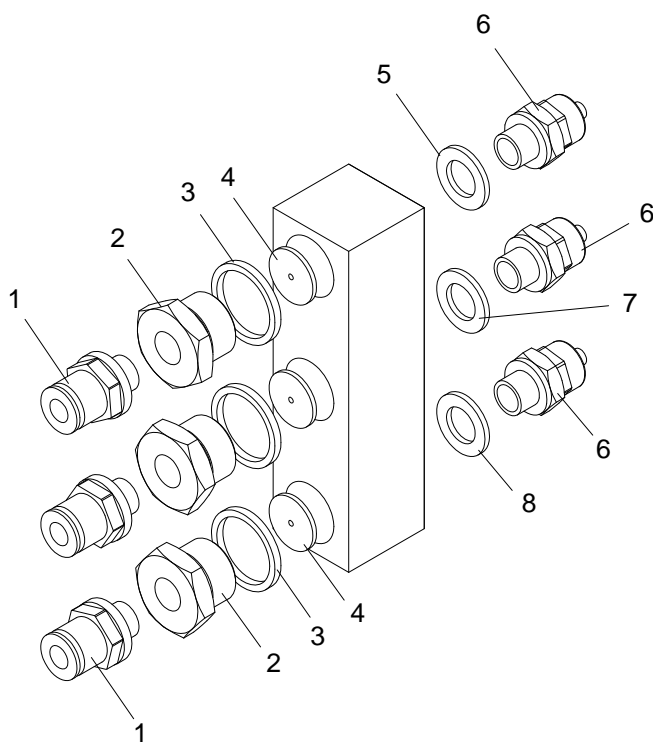

DES04860

Item	Part Number	Description	Qty	Sale Unit	Level for spare part (*)
	<b>EU72024021</b>	<b>Air output block assembly</b>	<b>1</b>	<b>1</b>	<b>3</b>
1	EU9000041	Straight fitting 1/8BSPM Dia: 6 plastic	3	1	2
2	EU2000031	Valve, Non return	3	1	3
3	EU9000042	Washer, sealing, 3/8BSP, nylon	3	1	2
4	EU2000037	Seal, non return valve	3	1	2
5	EU9000855	Washer 1/8BSP nylon black	1	1	2
6	EU9001045	Straight fitting 1/8BSP Dia: 6 metal	3	1	3
7	EU9001854	Washer, 1/8BSP nylon blue	1	1	2
8	EU9000853	Washer 1/8BSP nylon red	1	1	2

(\*)

**Level 1: Standard preventive maintenance**

**Level 2: Corrective maintenance**

**Level 3: Exceptional maintenance**

### 8.4.3. 2 and 4 bar Regulators

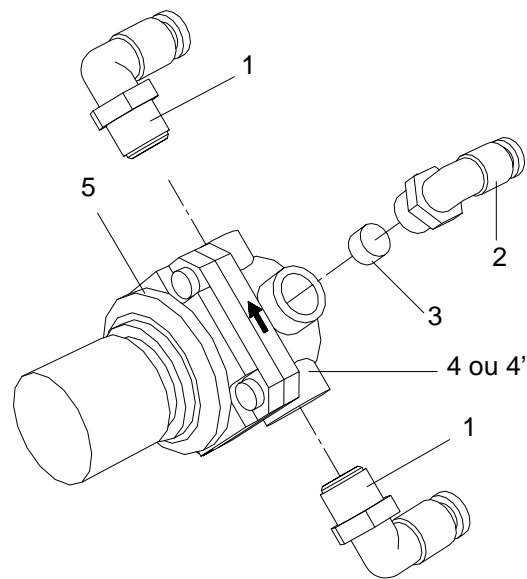

DES04861

Item	Part Number	Description	Qty	Sale Unit	Level for spare part (*)
	<b>EU72010018</b>	<b>Regulator assembly 4 bar</b>	<b>1</b>	<b>1</b>	<b>3</b>
	<b>EU72000026</b>	<b>Regulator assembly 2 bar</b>	<b>1</b>	<b>1</b>	<b>3</b>
1	EU9000033	1/4" elbow fitting for hose Dia: 6	2	1	3
2	EU2000062	1/8" elbow fitting for hose Dia: 4	1	1	3
3	EU5000050	Porous disc Dia: 8 thickness: 3.2 mm	3	1	2
4	EU9000112	Regulator 4 bar	1	1	2
4'	<b>EU9000111</b>	<b>Regulator 2 bar</b>	<b>1</b>	<b>1</b>	<b>2</b>
5	EU2024015	Regulator seal	1	1	1

(\*)

**Level 1: Standard preventive maintenance**

**Level 2: Corrective maintenance**

**Level 3: Exceptional maintenance**

#### 8.4.4. Pressure gauge assembly

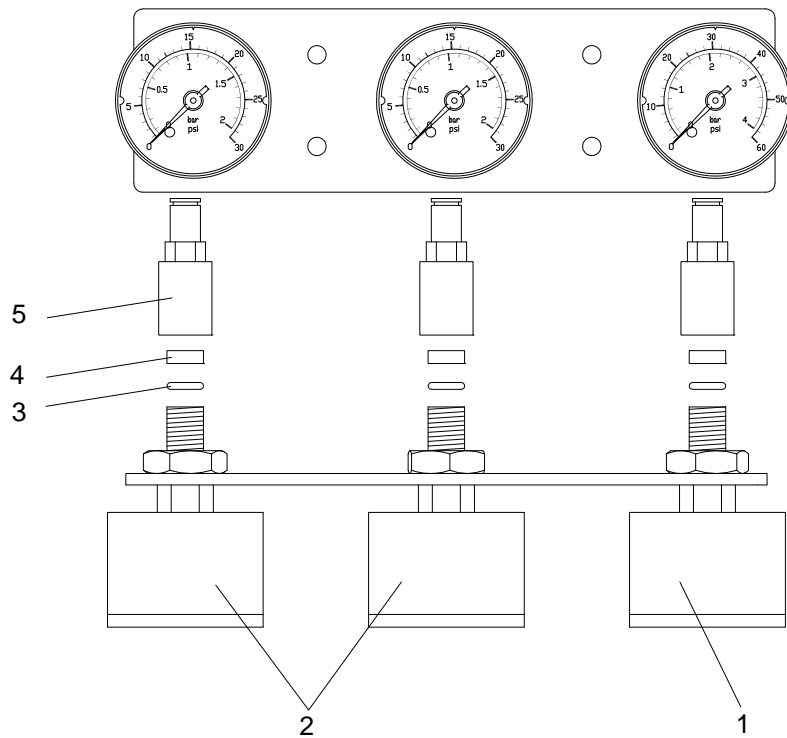

DES04862

Item	Part Number	Description	Qty	Sale Unit	Level for spare part (*)
	<b>910009000</b>	<b>Pressure gauge assembly</b>	<b>1</b>	<b>1</b>	<b>3</b>
1	EU2024020	Pressure gauge - 4 bar	1	1	3
2	EU2024019	Pressure gauge - 2 bar	2	1	3
3	EU9000071	O-ring	3	1	2
4	EU5000040	Porous disc - Dia: 8 thickness: 4.7	3	1	2
5	EU9000052	Quick release female union	3	1	1

(\*)

**Level 1: Standard preventive maintenance**

**Level 2: Corrective maintenance**

**Level 3: Exceptional maintenance**