



From February 1st, 2017 SAMES Technologies SAS becomes SAMES KREMLIN SAS
A partir du 1/02/17, SAMES Technologies SAS devient SAMES KREMLIN SAS



User manual

Turbine Speed Controller BSC-100

FRANCE

SAS SAMES Technologies. 13 Chemin de Malacher 38243 Meylan Cedex
Tel. 33 (0)4 76 41 60 60 - Fax. 33 (0)4 76 41 60 90 - www.sames.com

USA

Exel North America. 45001 5 Mile Road, Plymouth, Michigan, 48 170
Tel. (734) 979-0100 - Fax. (734) 927-0064 - www.sames.com

Any communication or copying of this document, in any form whatsoever, and any use or divulging of its contents is forbidden without express written permission from SAMES Technologies.

The descriptions and characteristics contained in this document may be changed without prior warning and are in no way binding on SAMES Technologies.

© SAMES Technologies 2011



WARNING : SAS Sames Technologies is registered as a "Training Center" approved by the "Ministry of Employment".
Trainings with the aim of getting the necessary know-how to use and for the maintenance of your equipment can be organised all along the year.
A catalog is available upon request. Among the different training programmes proposed, you will be able to find the training which corresponds the best to your needs and production purposes. These trainings can be organised in your premises or in our training center based in our headquarters in Meylan.

Training Department :
Tel.: 33 (0)4 76 41 60 04
E-mail : formation-client@sames.com

SAS Sames Technologies operating manuals are written in French and translated into English, German, Spanish, Italian and Portuguese.

The French version is deemed the official text and Sames will not be liable for the translations into other languages.

Turbine Speed Controller BSC-100

1. Health and Safety Instructions - - - - -	4
2. Description - - - - -	4
3. Technical characteristics - - - - -	5
3.1. <i>Dimensions</i>	5
3.2. <i>Electrical characteristics</i>	5
3.3. <i>Operating and Setting Characteristics</i>	6
3.3.1. <i>Electrical environment requirements</i>	6
3.3.2. <i>Speed Setting Input</i>	6
3.3.3. <i>Turbine Speed Reading</i>	6
3.3.4. <i>Speed Measurement for Control</i>	6
3.3.5. <i>Speed Control Circuit</i>	7
3.3.6. <i>Turbine Speed Readout</i>	7
3.3.7. <i>Readout Disable</i>	7
3.3.8. <i>Fault</i>	7
3.3.9. <i>Brake</i>	7
3.3.10. <i>Bell Stopped Indication</i>	7
3.3.11. <i>Start-up</i>	7
3.3.12. <i>Microphone Failure</i>	8
3.3.13. <i>Shutdown Sequence</i>	8
4. Adjustments, Test Points and Jumpers - - - - -	9
4.1. <i>Adjustments</i>	9
4.2. <i>Test Points</i>	10
4.3. <i>Jumpers</i>	10
4.4. <i>User Adjustments</i>	10
5. I/O Connectors - - - - -	11
5.1. <i>Connector JA</i>	11
5.2. <i>Connector JB</i>	12
6. Troubleshooting - - - - -	13
6.1. <i>Module Operation - Control Procedure</i>	13
6.2. <i>Failure Occurs in the Course of Operation</i>	13
7. Spare parts- - - - -	14

1. Health and Safety Instructions



WARNING : This equipment may be dangerous if it is not used in compliance with the regulations specified in this manual and in all applicable European standards or national safety regulations.

For PCB health and safety instructions (electrical environment requirements), [see § 3.3.1 page 6](#) .

2. Description

The BSC-100 has been engineered to control high-speed turbine (100 krpm).

The BSC-100 receives a speed setting input either locally or remotely, and receives a turbine speed sense via microphone.

The BSC-100 regulates the drive air to keep the turbine speed nearly equal to the setting.

Front face of the BSC-100:

- A 3-digit readout for turbine speed in krpm (Item 1).
- A potentiometer for local speed control. (Item 2).
- A local / remote switch (Item 3).
- Three LEDs indicating over speed, under speed, and fault (Item 4).

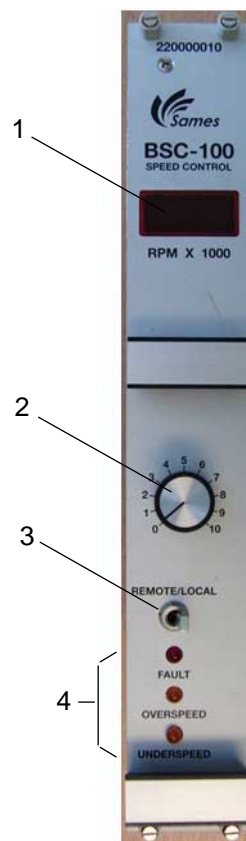

3. Technical characteristics

3.1. Dimensions

The BSC-100 is a modular plug in type unit, which is sized for all standard 6U height sub racks.

The dimensions for the unit are **266.7 mm (H) by 40.3 mm (W), by 172.5 mm (L)**.

The connectors are at the rear of the module. They connect all power and I/O signals to the printed circuit board.

The front panel is 2.5 mm aluminium.

3.2. Electrical characteristics

PCB Power input Requirements	+24 VDC / -24VDC / (20Vmin/26Vmax)
PCB Power input Consumption	6 Watts
Analog Inputs	0 - 10 VDC $Z_{in} = 30\text{ K}\Omega$
	4 - 20 mAADC $Z_{in} = 50\ \Omega$
Analog Outputs proportional solenoid valve	V/P 0 - 10 VDC - $I_{max} = 9\text{ mA}$
	I/P 4 - 20 mA
Speed Sense	0 -10 V - 1V/10 krpm
Fault Relay Contacts	4A @ 115 VAC
Brake Relay Contact	5A @ 115 VAC
Remote Interlock Contact	1A @ 24 VDC
Bell Stopped Contacts	1A @ 115 VAC
Operating temperature	+0°C to +45 °C
EMI Compliance *	EN61000-6-4 (ed2007) / 61000-6-2 (ed2005)

(* : [see § 3.3.1 page 6 electrical environment requirements](#)).

3.3. Operating and Setting Characteristics

3.3.1. Electrical environment requirements

To ensure an undisturbed speed control in industrial environment, the **BSC-100** PCB will be placed in a box or cabinet closed and properly grounded (as a short grounded copper braid).

All ground (GND) will be connected to the common ground and to the main ground as short as possible.

The main supply will be filtered by an EMI industrial filter and power supplies +24VDC and -24VDC will be in accordance with the industry standard EN61000-6-4 (ed2007) and EN61000-6-2 (ed2005).

For all input / output signals cables, a ferrite could be placed (2 turns of cable inside ferrite) and closest to the PCB connector.

For Turbine Speed Reading cable, a ferrite will be placed closest to the PCB connector.



WARNING : The ECM (electromagnetic compatibility) tests were carried out with a ferrite type WURTH 742 711 32 (impedance 2 turns 100 MHz, 755 Ω).

3.3.2. Speed Setting Input

When the switch on the front panel (SW1) is in the local position the speed setting is controlled by the potentiometer on the front panel. The scale, which reads 0 to 10, is merely used as a reference.

When the switch is in the "**Remote**" position, the speed is set remotely with a 0-10V or 4-20 mA input.

With SEL2 & SEL3 in the 60 krpm position, a 10V or 20 mA input will set the speed to 60 krpm. When SEL2 & SEL3 are in the 100 krpm positions, a 10V or 20 mA remote input will result in a 100 krpm turbine speed.

The 60 krpm selection allows for the replacement of a BSC-60, without the need of rescaling.

3.3.3. Turbine Speed Reading

Compressed air (adjustable 20 PSI – 40 PSI) passes through a tube and reaches the turbine. The sound produced by the rotating turbine is picked up by the microphone and sent to the BSC-100 where it is amplified. The gain of the MIC amplifier is adjusted automatically for the optimum signal strength.

The length of the tube from the turbine to the microphone must be no greater than 5 meters (15 feet) for HVT atomizers and between 5 and 7 meters (15 feet and 25 feet) for all the other atomizers.



WARNING : To ensure an undisturbed speed control in industrial environment, a ferrite will be placed on the cable (2 turns of cable inside ferrite) and closest to the PCB connector.

3.3.4. Speed Measurement for Control

The speed measurement for use by the control circuit is converted into a voltage by a PLL. This voltage is adjusted to 0-10V 1V/10 krpm by potentiometer P1. The PLL can lock onto the turbine from 16,000 rpm to 99,000 rpm.

3.3.5. Speed Control Circuit

The speed measurement voltage is compared to the speed setting voltage and the error amplifier amplifies the difference or error. This error voltage is sent to the proportional solenoid valve (after conversion to 4-20 mA) to adjust the drive air for minimum error. The higher the error amplifier or "loop gain", the less difference there is between the setting and turbine speed. If the gain is too high; however, the speed control may become unstable and the gain will need to be reduced.

The loop gain is adjusted by P3 - CW increases the gain, CCW reduces the gain.

3.3.6. Turbine Speed Readout

The signal from the voltage-controlled oscillator (VCO) is fed to a counter supplying a count value within a given time period which can be adjusted through potentiometer P8.

This VCO frequency oscillator is a multiple of the microphone frequency.

The counter value will be transferred to the readout as soon as the time set with P8 has elapsed.

3.3.7. Readout Disable

The readout is disabled at speeds below 16,000 rpm.

3.3.8. Fault

The turbine speed is monitored and compared to the speed setting by a micro controller. If the monitored speed is more than 3 krpm from the set speed the over speed or under speed light will be turned on. If the speed remains outside these limits for more than 10 seconds a fault will occur. The fault light will turn on and the fault relay will go to the faulted position.

The fault will be reset when the bell stays within the over speed and under speed limits for 3 seconds. The fault can be manually reset by setting the speed setting input to 0 rpm.

3.3.9. Brake

The brake is used to rapidly reduce the speed of the turbine when the setting has been lowered.

The brake is released when the speed comes within 5 krpm of the new setting.

If the setting is reduced to 0 rpm, the micro controller will estimate the time required to maintain the brake after the MIC signal is lost, to bring the turbine to a stop.

3.3.10. Bell Stopped Indication

The Bell Stopped contacts are used to indicate the bell has finished braking.

The bell may not be completely stopped, depending on the microprocessors estimate on braking duration, but the speed should be low enough to safely remove bearing air

In the event that the microphone fails, the bell stopped indication will wait for 2 minutes after the speed setting is set to zero before the stopped indication is given.

3.3.11. Start-up

When the speed setting is raised above 0 rpm, the **BSC-100** applies a maximum drive output for 1 second.

This is to ensure the turbine starts spinning, and to avoid a possible no start condition, which could happen if there was noise present on the microphone during the initial starting.

3.3.12. Microphone Failure

When a microphone failure occurs, the closed loop speed control will cause the turbine drive to go full speed trying to make the turbine speed match the setting. This could cause the turbine to exceed the maximum recommended speed.

If a microphone failure is detected, a fault will occur after approximately 3 seconds. The over speed and under speed lights will come on as well as the fault indication. The turbine drive output should be run through a set of the fault contacts to prevent the turbine from exceeding the maximum rated speed.

When a fault is detected the speed setting input should be set to 0. After a 0 speed setting is requested, the bell-stopped indication will occur after a 2-minute delay. The over speed and under speed lights will blink alternately during the 2-minute delay period.



WARNING : To prevent failure of the microphone signal in industrial environment, a ferrite must be placed on the cable (2 turns inside ferrite) and closest to the PCB connector.

3.3.13. Shutdown Sequence

The proper shutdown of the **BSC-100** requires:

- 1 The bell speed setting is set to 0 rpm.
- 2 The bell will require up to 2 minutes for the bell to stop spinning depending on the initial speed and air brake pressure etc. The bell stopped signal will give an indication when the bell stops.
- 3 After the bell has stopped the power can be shut off.

4. Adjustments, Test Points and Jumpers

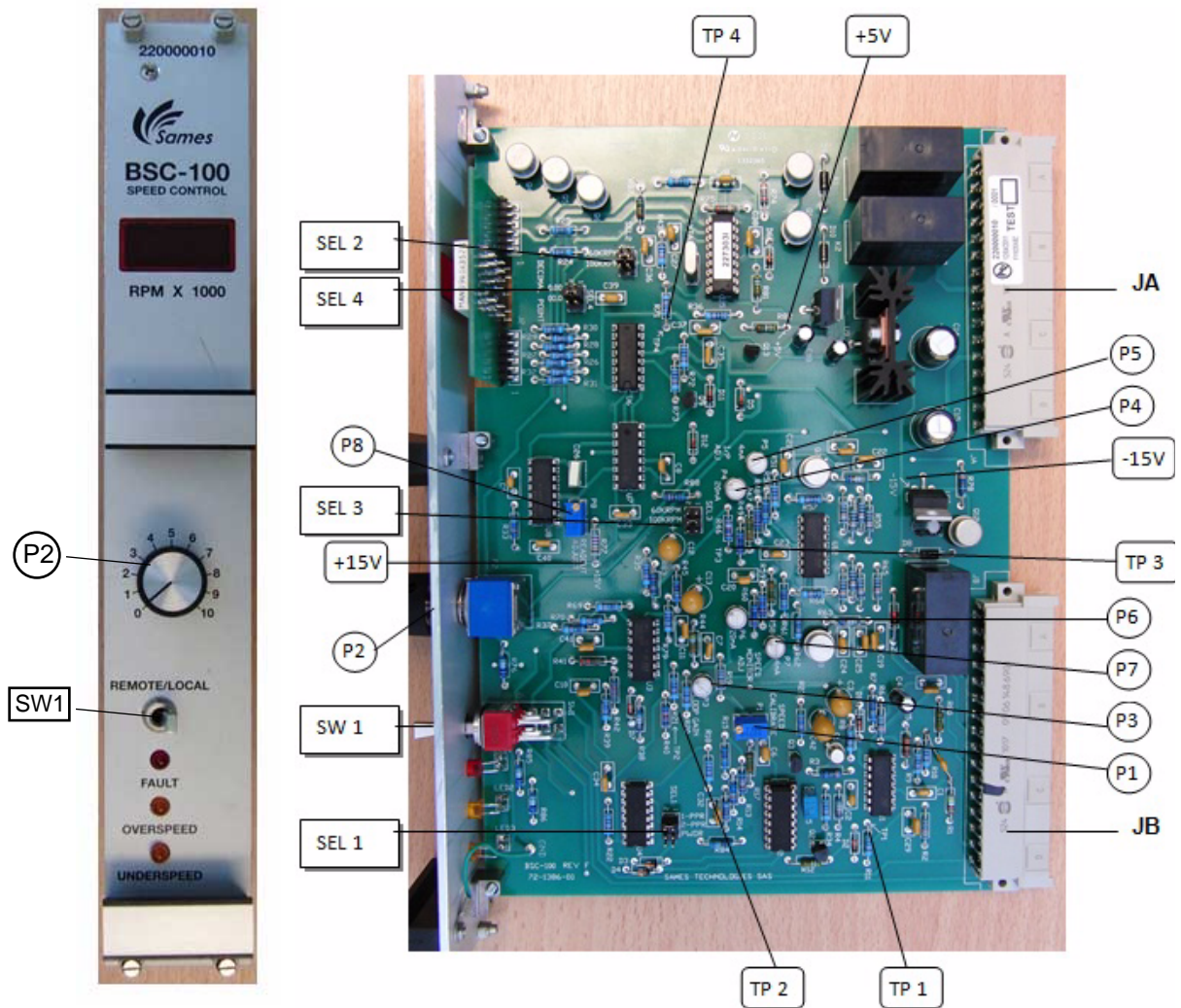

4.1. Adjustments

- **P1** Speed Calibration
- **P2** Local Speed Setting in "local" position
- **P3** Loop Gain Adjustment
- **P4** I/P 20 mA adjust
- **P5** I/P 4 mA adjust
- **P6** Speed Monitor 20 mA adjust
- **P7** Speed Monitor 4 mA adjust
- **P8** Readout Calibration adjust

4.2. Test Points

- **TP1** Microphone Amplifier Output
- **TP2** Speed Measure Output 0 -10V
- **TP3** Drive Output Voltage 0 -10V
- **TP4** Set Speed Reference Voltage
- **+ 15V** From Regulator
- **- 15V** From Regulator
- **+ 5V** From Regulator

4.3. Jumpers

Jumpers are used to configure the board for various applications. They are factory installed and should not be removed.

- SEL1 Pulses per Revolution Selection
- SEL2, SEL3 Speed Scaling 60 krpm or 100 krpm.
- SEL4 Decimal Point 0.00, 00.0.

Jumper's configurations:

- High Speed Turbine using :
 - Atomizers range 7 type PPH707, Accubell 708,...
 - SEL1 : 1-PPR
 - SEL2 SEL3 : 100 krpm
 - SEL4 : 00.0
- PAM Turbine using :
 - Atomizers type PPH308, PPH 607,Nanobell...
 - SEL1 : 1-PPR
 - SEL2 SEL3 : 60 krpm
 - SEL4 : 00.0
- Ball bearing Turbine using
 - Atomizers type PPH405, PPH 307,PPH 508
 - SEL1 : 2-PPR
 - SEL2 SEL3 : 60 krpm
 - SEL4 : 00.0

4.4. User Adjustments

User adjustments have been incorporated for best possible tuning of the BSC-100.

Loop Gain Adjustment

Adjust gain with potentiometer P3. The factory setting should be adequate. CCW decreases the gain and CW increases the gain.

If the turbine speed is unstable, the gain might be too high and may need to be reduced. If the speed lowers too much when the turbine is under load, when paint is flowing, the loop gain may need to be increased.

5. I/O Connectors

5.1. Connector JA

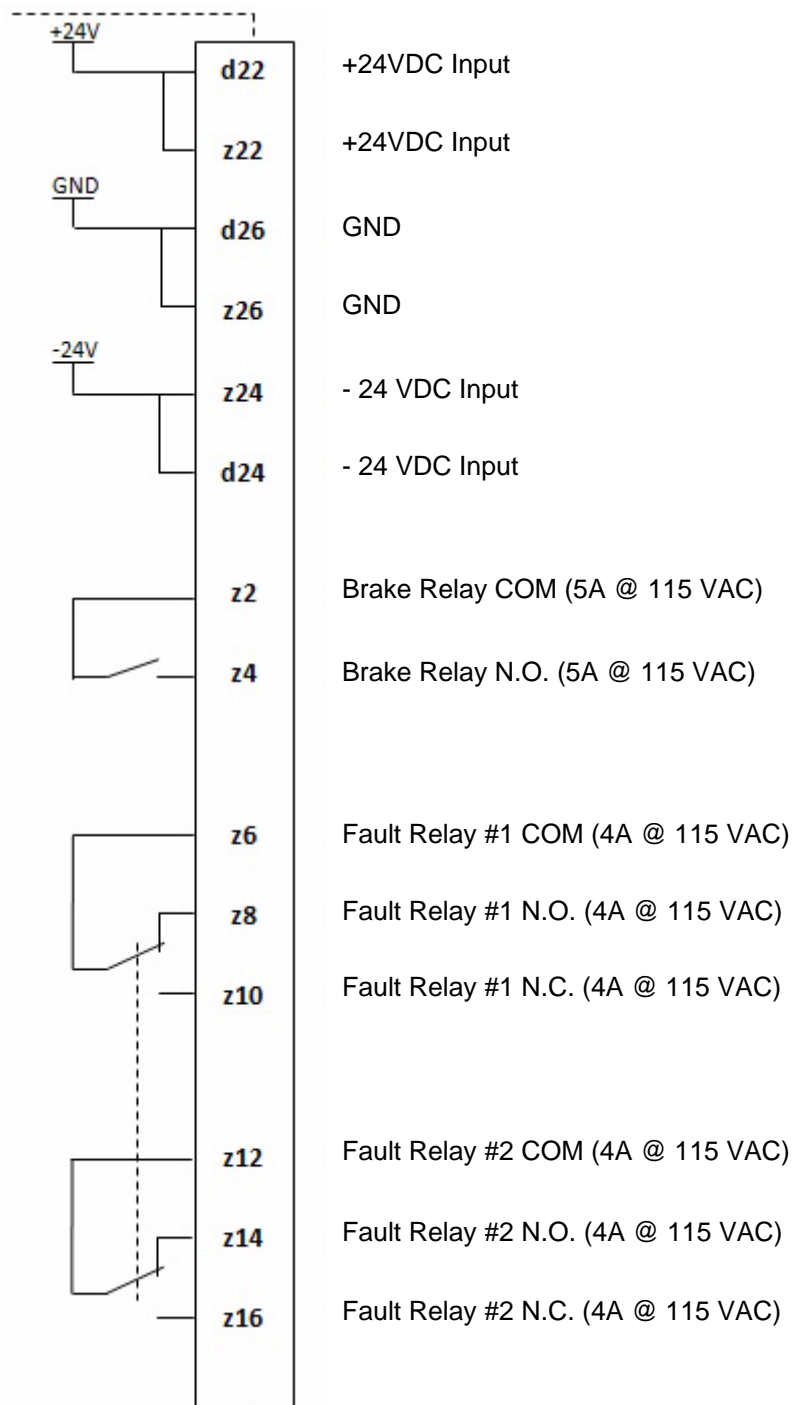

(fault relay 1 & 2 shown with power on in non-faulted state)

5.2. Connector JB

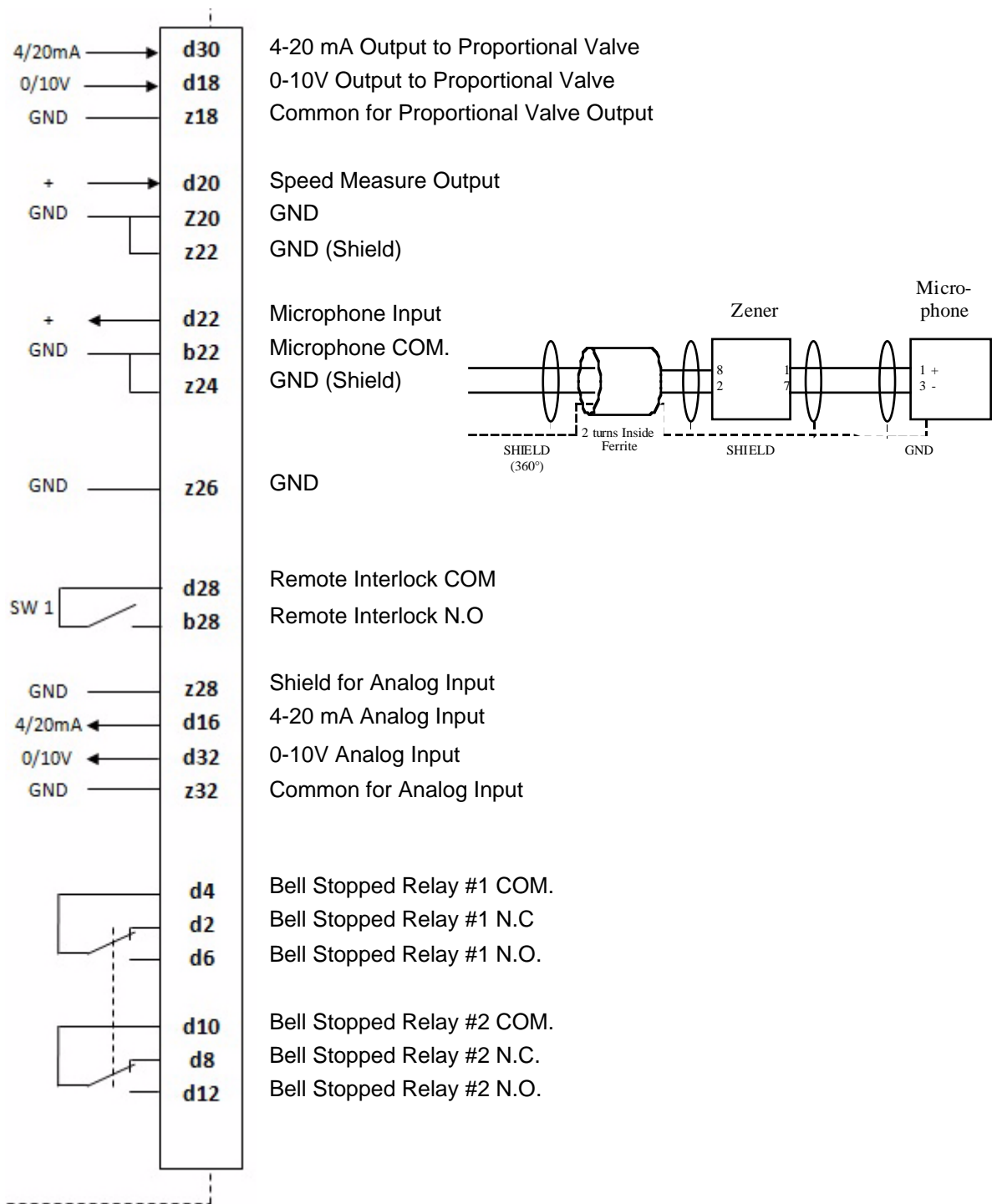

6. Troubleshooting

6.1. Module Operation - Control Procedure

Step 1:

- Make sure the turbine rotation pneumo-valve is connected to the mains.
- Make sure air is sent through the microphone; air pressure reading on the pressure gauge located inside the pneumatic control cabinet is usually between 1 and 2.5 bars (20-40 PSI), but this value depends on tube length.
- The microphone pick-up tube must be no greater than 5 meters (15 feet) long for HVT atomizers. The pick-up tube must be between 5 and 7 meters (15 and 25 feet) for all others.
- Set front panel switch SW1 to (local mode).
- Set the set-point valve to approx. 20,000 rpm through the front panel potentiometer P2.

Step 2:

- Ensure correct operation over the whole speed range (between approx. 16 rpm to 65 krpm or 99 krpm according to the type of turbine and atomizer).
- Adjust air pressure on the microphone if required by:
 - Increasing air flow-rate if display is lost at high speeds.
 - Reducing air flow-rate if saturation is too high (risk of double measurement).
- Setting switch SW1 to the external set-point pos. (remote mode): make sure the programmable logic controller set-point is transmitted and that the bell rotates in the required direction (anti-clock-wise).
- **Braking control:** display a 40,000 rpm speed set-point (remote mode), then a 20,000 rpm speed set-point (local mode).
- When passing from the remote mode to the local mode through switch SW1:
 - check that the braking solenoid valve operates properly (quick drop from 40,000 rpm to 20,000 rpm on the display unit).

6.2. Failure Occurs in the Course of Operation

The electronic board operates satisfactorily (after checking procedure [see § 6.1 page 13](#)).

Failures may be due to:

- **The set-point forwarded to the turbine exceeds the maximum allowable value:** as may be the case when high viscosity paints are being sprayed (high flow-rate):
 - 1 Decrease table speed.
 - 2 Adjust loop gain P3 if necessary.
 - 3 Make sure the air supply system is able to deliver the required flow-rate.
 - 4 Verify if the ferrite is placed on the microphone cable (2 turns inside ferrite) and closest to the PCB connector.
 - 5 All links satisfy the grounded requirements.
 - 6 Power supplies and main filter satisfy standards requirements.
- **A failure occurs after the turbine has been stopped, then restarted**
 - 1 Make sure that turbine does not rotate after being turned off.
 - 2 Place a time-out upon failure recognition (speed reading through microphone only) between the stop and the required speed set-point. The time lag shall not be longer than the set-point value is high.
- **Failures may also be due to**
 - 1 A pressure drop across the air supply system.
 - 2 Aging of the turbine.
 - 3 Humidity in microphone air system (impossibility to reach the setting speed).

7. Spare parts

Part Number	Description	Sale unit
220000010	Turbine Speed Controller BSC-100 100 krpm for HVT	1
220000157	Turbine Speed Controller BSC-100 60 krpm for magnetic air bearing turbine	1
E7ADEV036	Extended board : Din41612 U6 Connector F48	1
110001534	Ferrite clip type WURTH 742 711 32 (impedance 2 turns 100 MHz, 755 Ω)	1