



Binks Sames

From February 1st, 2017 SAMES Technologies SAS becomes SAMES KREMLIN SAS
A partir du 1/02/17, SAMES Technologies SAS devient SAMES KREMLIN SAS



INSTRUCTIONS MANUAL

PAINT SUPPLY STATIONS

TYPE CPV 201

TYPE CPH 301 - 302

VITREOUS ENAMEL SUPPLY STATIONS

TYPE CTH 301-302 (Ang)

Nature of the modification: revision of the existing document.

Established by:

DE LUCA Ph.

Checked by:

Checked by:

RODRIGUES J.

Approved by:

VEYRAT D.

The information and characteristics given in this manual are not contractually binding and **BINKS-SAMES** reserves the right to modify the equipment without prior notice.

CONTENTS	Page
1. GENERAL DESCRIPTION	4
1.1. "EARTHED" TYPE SUPPLY STATIONS	4
1.2. "INSULATED" TYPE SUPPLY STATIONS	4
2. CONSTITUENT ELEMENTS	4
2.1. "EARTHED" SUPPLY STATION - CPV 201 CONSISTS OF:	4
2.2. "INSULATED" SUPPLY STATION - CPH 301 CONSISTS OF:	4
3. DIMENSIONS	5
3.1. "INSULATED" SUPPLY STATION CPH 301 - CPH 302	5
3.2. MOTOR-PUMP ASSEMBLY CPH 301 - CPH 302	6
3.3. "EARTHED" SUPPLY STATION CPV 201	6
3.4. PAINT PUMP	7
4. DESCRIPTION OF COMPONENTS	8
4.1. DRIVING UNIT	8
4.2. PAINT PUMPS	8
4.3. SPEED REGULATOR	9
4.4. REGULATOR TYPE 431	10
4.5. REGULATOR TYPE 432	11
5. DIFFERENT MODELS OF PAINT SUPPLY STATIONS	12
5.1. ASSEMBLY WITH PUMP BY-PASS VALVE (SEE FIGURE 7)	12
5.2. ASSEMBLY WITH RETURN CIRCUIT AND DRAINAGE VALVE (SEE FIGURE 8)	13
5.3. ASSEMBLY WITH PUMP BY-PASS AIR VALVE (SEE FIGURE 9)	14
5.4. ASSEMBLY WITH RETURN CIRCUIT AND DRAINAGE AIR-VALVE (SEE FIGURE 10)	15
6. ASSEMBLY OF THE SPEED REGULATOR	16
6.1. REGULATOR; TYPE 431 (SEE SECTION 4.4)	16
6.2. REGULATOR, TYPE 432 (SEE SECTION 4.5)	16
7. CONNECTING CABLES	16
8. ELECTRICAL CONNECTIONS	16
8.1. REGULATOR; TYPE 431 (SEE SECTION 4.4)	16
8.2. REGULATOR, TYPE 432 (SEE § 4.5)	17
9. START-UP	17
9.1. PAINT PUMP	17
9.2. SPEED REGULATOR	18
10. DISMANTLING OF THE PUMP	19
10.1. DISMANTLING OF GEARS	19
10.2. REPAIR THE PUMP AFTER SEIZURE	20
11. MAINTENANCE	20
11.1. MOTOR	20
11.2. SPEED REDUCER	20
11.3. PAINT PUMP	21
12. TROUBLE SHOOTING	22
13. ENAMEL SUPPLY STATIONS CTH 301 - CTH 302	23
13.1. MAINTENANCE	23
13.2. DISMANTLING OF THE "DOSEMAIL" PUMP (SEE FIGURE 11)	23
14. SPARE PARTS	25
ID01-A - SPARE PARTS CPV 201 - CPH 301/CPH 302	26
ID02-A - DOSEMAIL PUMP	27
ID03-01-A - DOSEMAIL PUMP SUPPORT	28
ID03-02-A - DOSEMAIL PUMP SUPPORT	29
ID03-03-A - DOSEMAIL PUMP SUPPORT	30
ID04-A - DISTRIBUTOR SUPPORT ASS'Y	31

1. GENERAL DESCRIPTION

Liquid product supply stations can be divided into two types, for use according to the resistivity of the product to be applied

1.1. "EARTHED" TYPE SUPPLY STATIONS

For products with a resistivity greater than about 1 M Ω .cm, the paint distribution circuit is earthed a few metres behind the atomizer heads and before the supply station, which remains at zero potential.

"Earthed" type supply stations are designated by the letters: **CPV**.

1.2. "INSULATED" TYPE SUPPLY STATIONS

An "earthed" supply station cannot be used for products whose resistivity is less than 1 M Ω .cm as the leakage of current along the paint supply ducts, from the atomizer heads at high voltage, becomes far too great. The voltage drop caused by this leakage of current may be so serious that maintenance of electrostatic operation at acceptable levels is no longer possible.

With water soluble products, this may even result in short-circuiting of the generator through the supply ducts.

These problems can be avoided by use of an "insulated" type supply station in which the dosing pumps are insulated from the metal framework for a voltage corresponding to that of the high voltage generators used.

A supply station of this kind is essential if metallic paints are to be used.

The "insulated" type supply stations are designated by the letters **CPH**.

2. CONSTITUENT ELEMENTS

2.1. "EARTHED" SUPPLY STATION - CPV 201 CONSISTS OF:

- driving unit with variable speed,
- speed regulator for the driving unit,
- volumetric pump,
- flexible motor-pump transmission coupling,
- metal framework for the motor-pump assembly.

2.2. "INSULATED" SUPPLY STATION - CPH 301 CONSISTS OF:

- driving unit with variable speed,
- volumetric pump,
- flexible motor-pump transmission coupling,
- metal framework for the motor-pump assembly,
- speed regulator for the driving unit.

The framework may be fitted with one or two pumps; in the latter case, the designation used is **CPH 302**.

Note : both **CPV** and **CPH** supply stations may be optionally equipped with a paint filter with removable cartridge.

3. DIMENSIONS

3.1. "INSULATED" SUPPLY STATION CPH 301 - CPH 302

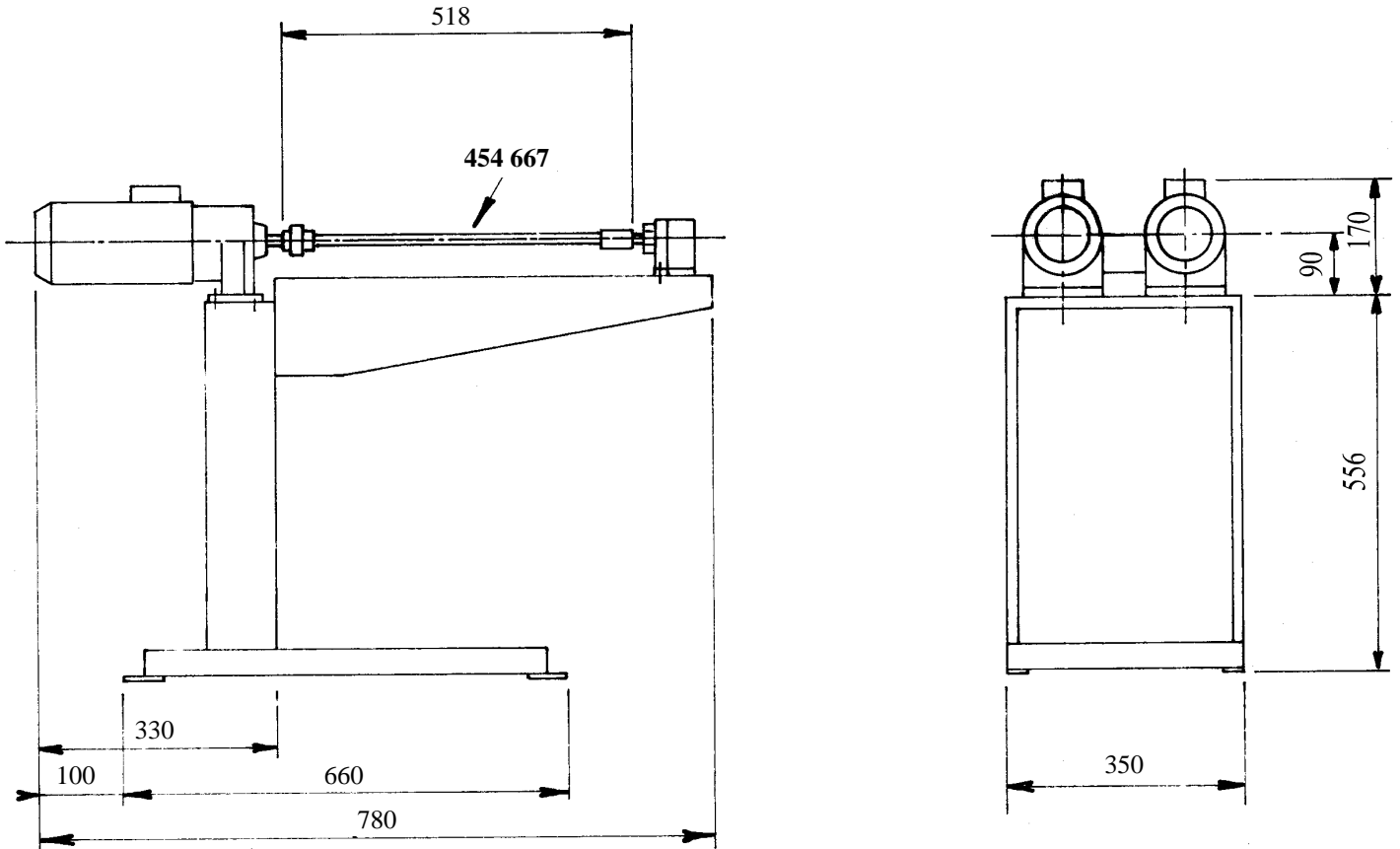

Figure 1

3.2. MOTOR-PUMP ASSEMBLY CPH 301 - CPH 302

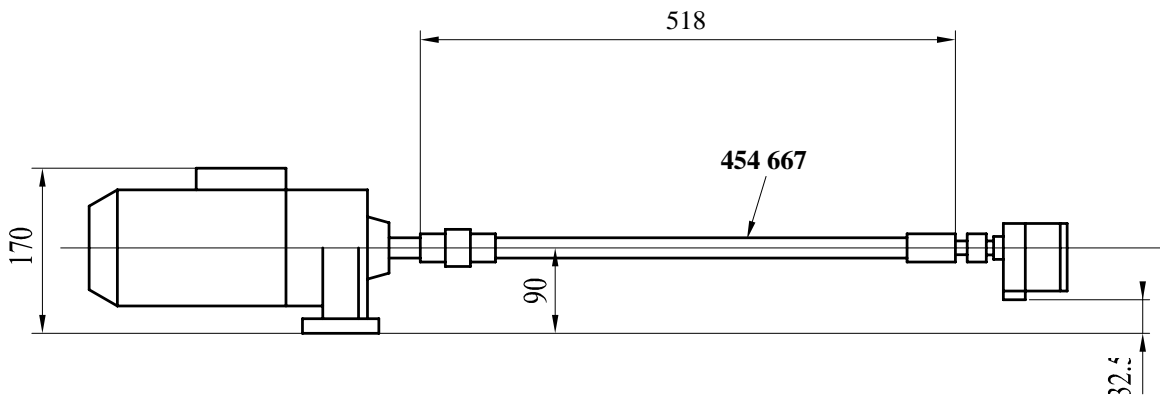

Figure 2

3.3. "EARTHED" SUPPLY STATION CPV 201

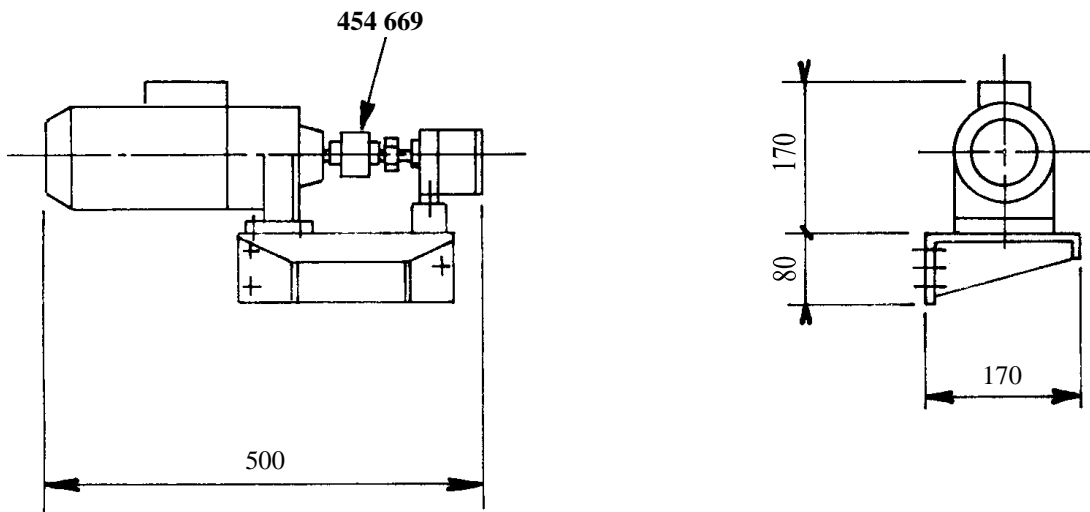

Figure 3

3.4. PAINT PUMP

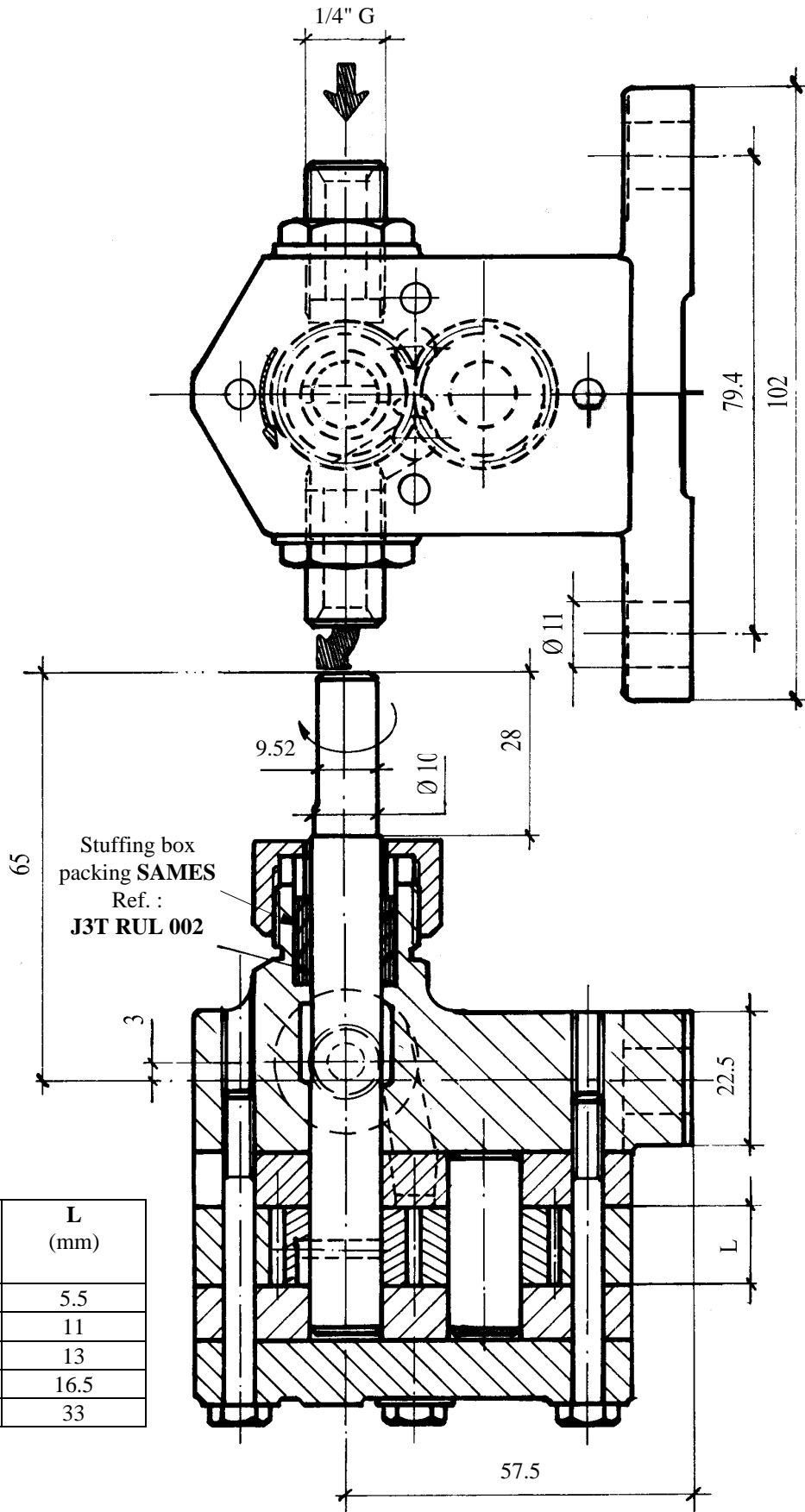

Figure 4

4. DESCRIPTION OF COMPONENTS

4.1. DRIVING UNIT

The volumetric pumps are rotated by a variator-reducer comprising a variable speed DC motor and a speed reducer. The speed is controlled by means of a “speed adjustment potentiometer”.

General characteristics:

4.1.1. MOTOR

- Type M 63 - 85 - separate excitation.
- Power..... 122 W.
- Safety standardIP 44 - enclosed motor.
- Speed range 150 to 3000 rpm.
- Insulation class B i.e. maximum 80 °C (176 °F) heating above ambient temperature of 40 °C (104 °F).

4.1.2. REDUCER

- Type.....Gearing model.
- Reduction ratio1/12.6.
- Torque at 3000 rpm 0.45 m.daN.
- Lubrication grease.
- “Lifetime” 25,000 hours of normal use.

4.2. PAINT PUMPS

Liquid products supply stations are equipped with gearing volumetric pumps

This type of pump has 5 different calibres defined by the number of cubic centimetres of product delivered per revolution (0.6, 1.2, 2.4, 3 - 6 cm³/revolution).

These different calibres permit regulation of output ranging from 0.5 to 80 litres/hour.

The pump body which determines fixation, height of shaft, shaft diameter, position and type of connection produced is common to all pump calibres, so that these are interchangeable on the supply station.

Given that the diameter of the gears is the same for all pumps, the calibre of each pump is defined by the thickness of the stator and gears which are sandwiched between two cheeks, the complete assembly being fitted between the pump body and a tightening cap.

The stator thickness corresponding to each calibre is shown in the following table:

Calibre (cm ³ /rev)	0.6	1.2	2.4	3	6
Thickness	5.5	11	13	16.5	33

Sealing at the level of the rotating pump driving shaft is ensured by means of Teflon wool packing; this is kept tightly packed by a sliding ring, the limits of which are adjusted by a nut screwing onto the pump body.

In order to keep this stuffing-box nut in place, the driving shaft must always rotate clockwise i.e. from left to right for an observer facing the driving shaft.

The direction of rotation of the driving shaft determines the direction of product flow through the pump; for an observer facing the shaft, the product inlet is on the left of the pump body and the product outlet on the right.

IT IS IMPERATIVE TO RESPECT THE DIRECTION OF ROTATION
--

Use of water soluble products requires specially adapted volumetric pumps.

These pumps come in the same calibres as those for conventional paints, and thus have the same output range.

As the dimensions of the water soluble pumps are identical to those of the conventional pumps, no modification of the supply station is required for changeover. For further information about these problems, please contact our technical services.

4.3. SPEED REGULATOR

GENERAL DESCRIPTION

These regulators supply direct current to the inductor and induced circuit of the M 63-85 motor which drives the rotation of the volumetric pumps.

Fed with single-phase voltage 220 - 240 V, 50/60 Hz, they supply the motor with a constant excitation voltage of 200 V maximum and an induced voltage adjustable from 0 to 180 V, allowing regulation of the speed of the DC motor.

A steady speed is maintained by electronic compensation which prevents the drop in speed associated with the load.

This torque compensation can be adjusted by a potentiometer "I x R".

The resulting speed accuracy is in order of 3 %. The range of speed variation is from 1 - 20. These values may vary slightly depending on the motor used and the load.

4.4. REGULATOR TYPE 431

To be integrated in the general control box

DIMENSIONS

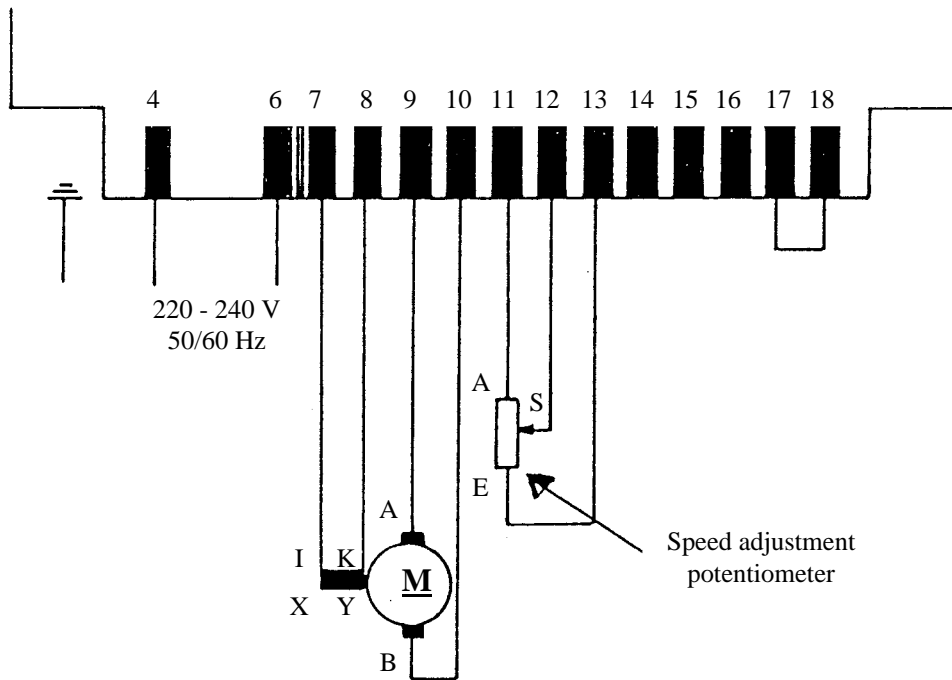
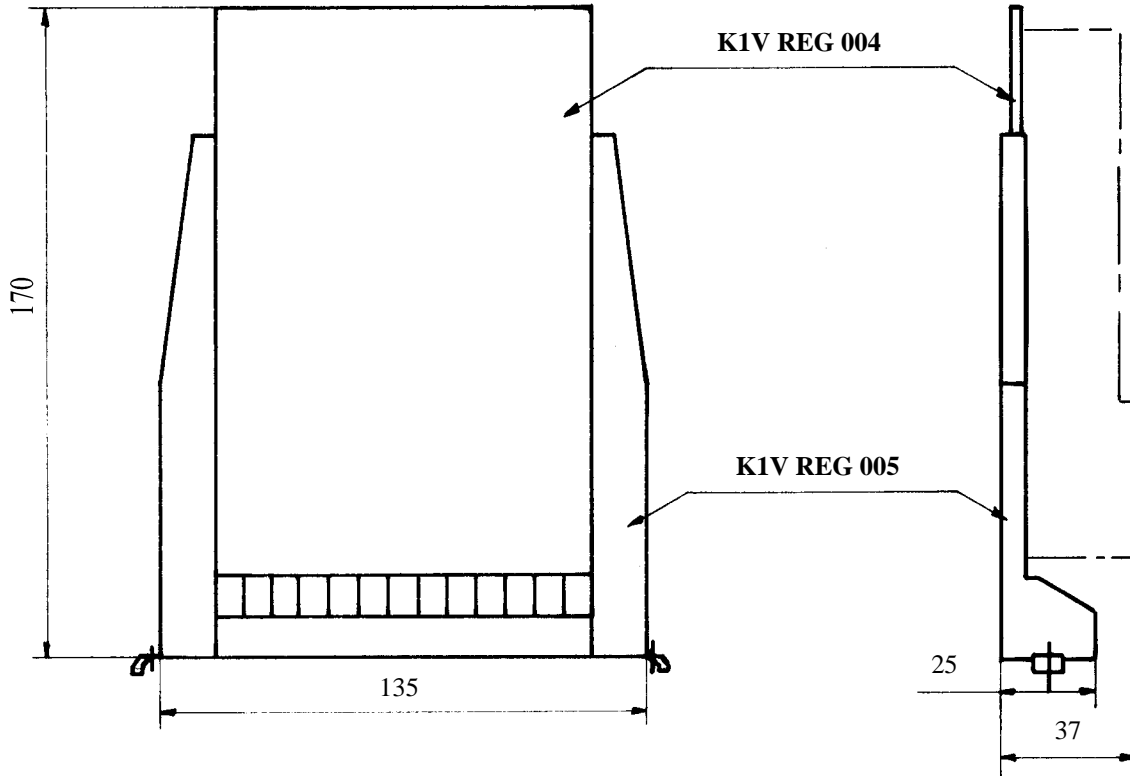

Figure 5 : CONNECTIONS DIAGRAM

4.5. REGULATOR TYPE 432

Delivered in its case.

DIMENSIONS

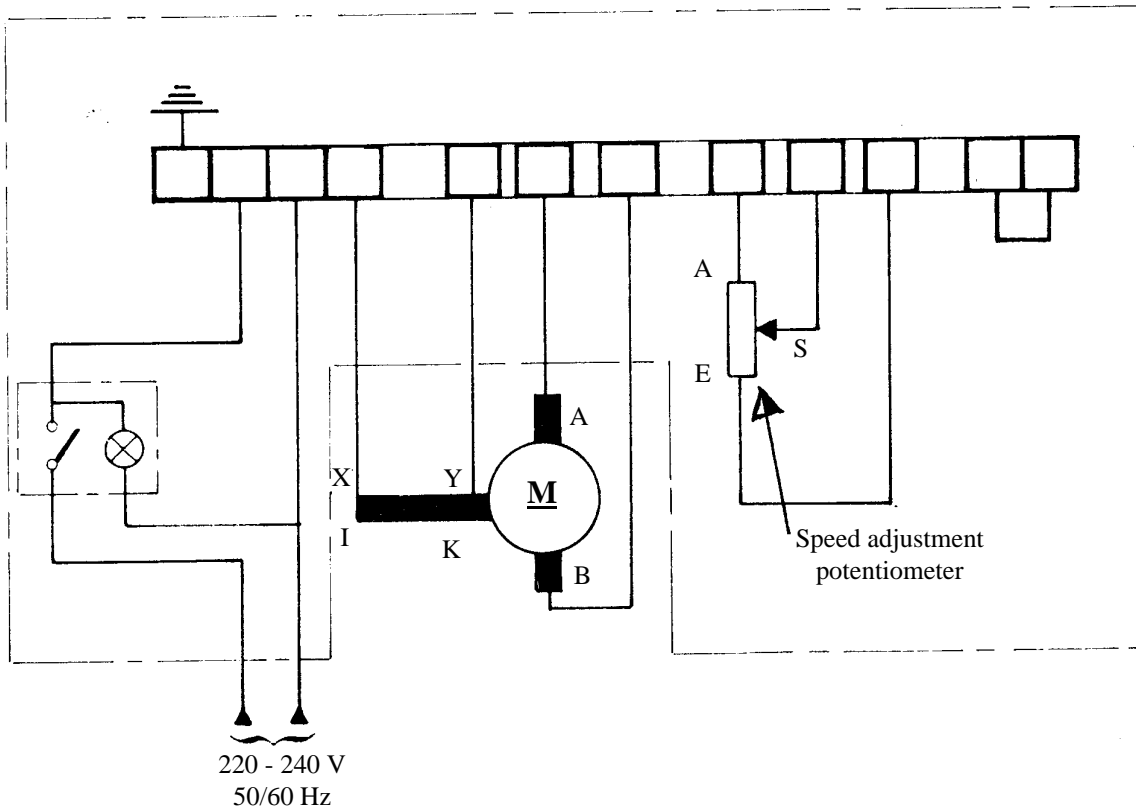
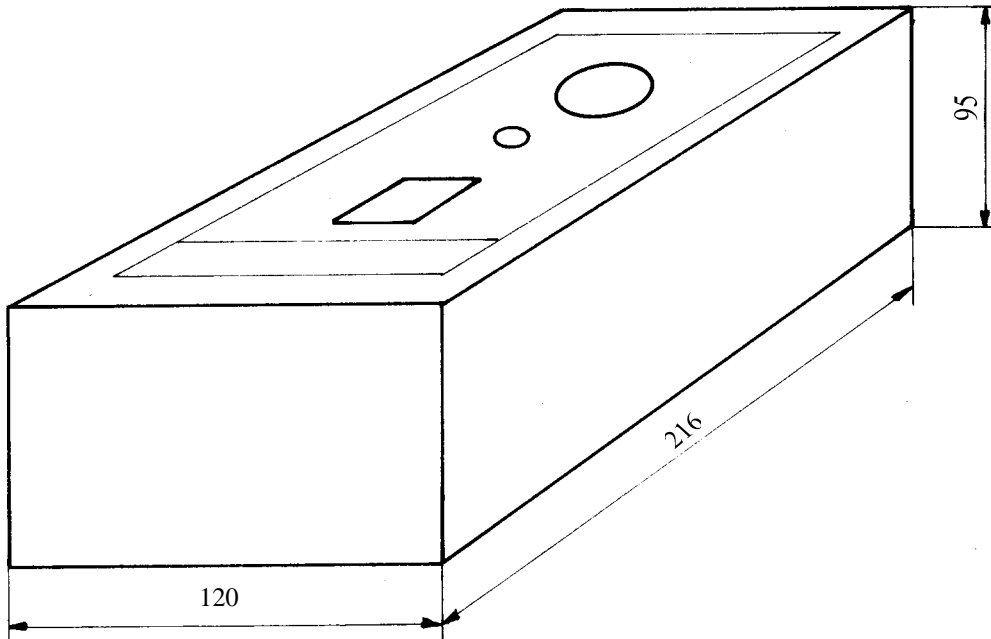

Figure 6 : CONNECTIONS DIAGRAM

5. DIFFERENT MODELS OF PAINT SUPPLY STATIONS

According to the product used, conditions of use, time and degree of automatization required for cleaning the circuit, supply stations can be equipped with different accessories adapted to the needs of these various situations.

The different models are shown in figs. 7, 8, 9 and 10.

Choice of model is based on the advantages and disadvantages of the differens models as described below.

5.1. ASSEMBLY WITH PUMP BY-PASS VALVE (SEE FIGURE 7)

This is a standard paint supply station assembly delivered when no special requirements are include in the order. Operation is as described elsewhere in this manual.

5.1.1.ADVANTAGES

- Simple circuit.
- Manual operation of by-pass.
- Length of paint circuit reduced to a minimum.
- Minimum volume of product and solvent lost during cleaning operations.

5.1.2.DISADVANTAGES

- Product and solvent cannot be recovered during cleaning of the paint circuit. During this operation all the paint and solvent are emptied into the booth.
- Speed of cleaning of the paint circuit for colour changing is reduced owing to manual operation.
- To stop spraying at the level of the atomizers, the driving motor must also be stopped. This limits the frequency of breaks.
- The absence of an air valve at the atomizer head may allow paint leaks after stoppage of the pumps, especially for low viscosity products.

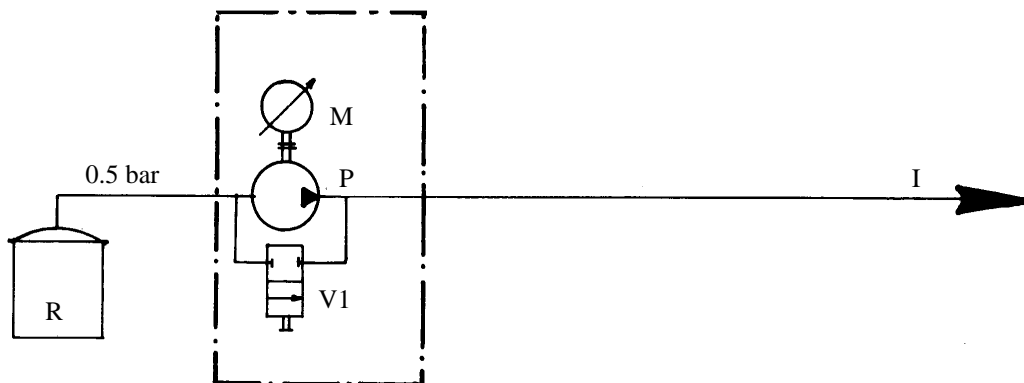

Figure 7

5.2. ASSEMBLY WITH RETURN CIRCUIT AND DRAINAGE VALVE (SEE FIGURE 8)

A 3-way air valve **PV1** at the level of the atomizer head allows the introduction of a product return circuit.

5.2.1. PRODUCT MIXING

Awaiting start-up of the atomization process, or during breaks in spraying, the pump remains in operation and the product circulates through the pump supply duct to the air valve from where it is returned via the return circuit to below the pump.

The product thus remains in constant circulation and is homogeneous and ready for spraying at any moment.

5.2.2. ATOMIZATION

Excitation of the air valve **PV1** results in closing of the product return circuit and supply of product to the atomizer **I**.

5.2.3. PAINT CIRCUIT RINSING

The paint supply **R** is replaced by a reservoir of solvent under pressure (5 to 6 bar).

The solvent flows through the return circuit up to the air valve **PV1** through which it passes at full flow, and continues back towards the pump; opening of valve **V2** allows collection of the solvent in the recovery container.

When rinsing is completed, the pump is started up for its own cleaning. After a certain time considered adequate for cleaning, input of solvent is stopped.

Refilling the circuit is carried out under the same conditions as circuit rinsing, after replacing the solvent reservoir by the paint supply and starting up the pump again.

When the paint arrives at the recovery container, refilling of the circuit is complete.

Valve **V2** is closed and the paint circuit returns to the "mixing" state.

5.2.4. ADVANTAGES

- Breaks in the atomization process can be more frequent.
- The product is always homogeneous, even after prolonged stoppages.
- Product and solvent are completely recovered during rinsing of the paint circuit.

5.2.5. DISADVANTAGES

- Owing the fact that the valve **V2** is manually operated, circuit cleaning cannot be an automatic process.
- Risk of human error due to absence of locking between the various control elements of the paint circuit.
- Circuit cleaning cannot be a rapid process when manually controlled.
- Considering the length of the paint supply ducts between the pump and the atomizer, and of the return circuit, loss of product and solvent during circuit rinsing is greater than in **figure 7**.

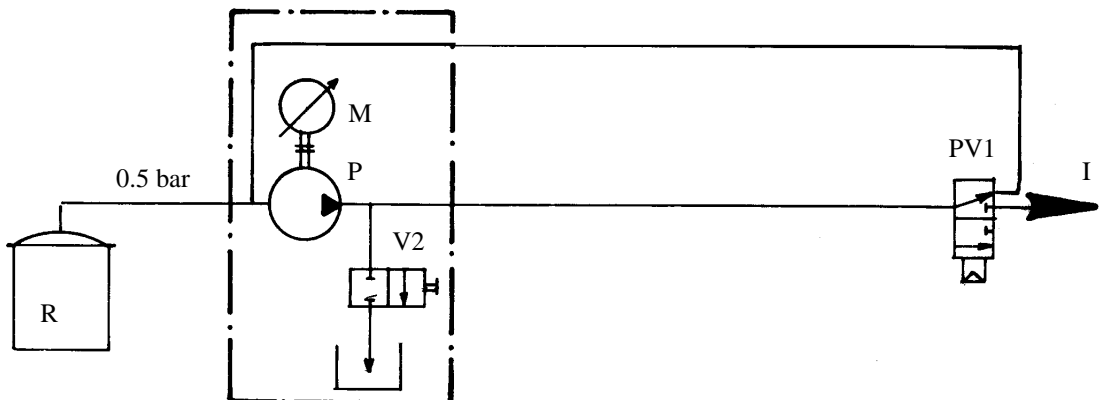

Figure 8

5.3. ASSEMBLY WITH PUMP BY-PASS AIR VALVE (SEE FIGURE 9)

5.3.1. OPERATION

In the rest position or awaiting atomization, air valves **PV2** and **PV3** are not excited. Valve **PV2** is normally open at rest and the flow supplied by the rotating pump is sent through the by-pass.

The signal for atomization causes simultaneous excitation of **PV2** and **PV3**, closing the pump by-pass and opening the paint circuit at the atomizer.

When atomization is stopped, the circuit returns to resting position, the pump continuing to operate.

The valve **V3** is a manually operated shut-off valve.

5.3.2. ADVANTAGES

- Possibility of frequent breaks in atomization.
- No leakage of paint from atomizer during breaks.
- Length of paint circuit reduced to minimum.
- Rinsing operation may be fully automatic, with consequent rapidity and elimination of errors.

5.3.3. DISADVANTAGES

- No mixing of product during breaks in atomization.
- Recovery of product and solvent during circuit cleaning impossible as the flow evacuated must pass through the atomizer.

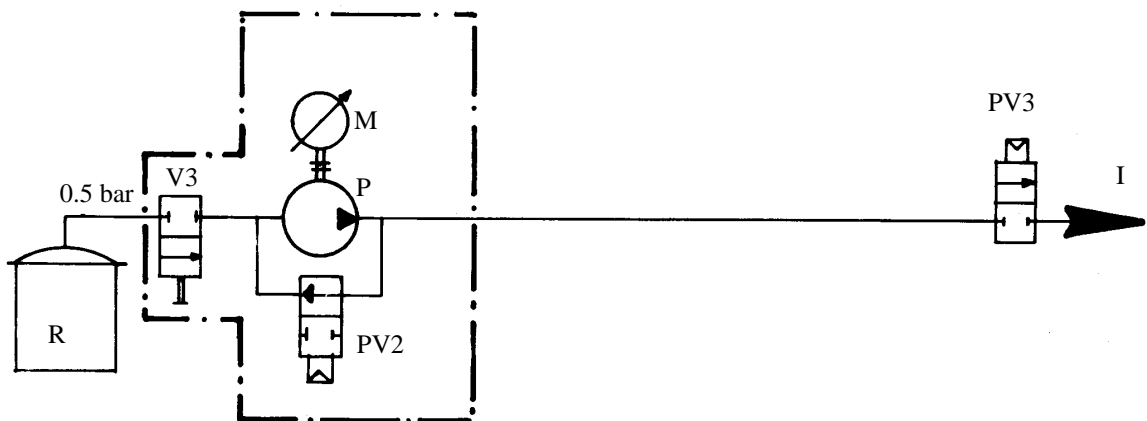

Figure 9

5.4. ASSEMBLY WITH RETURN CIRCUIT AND DRAINAGE AIR-VALVE (SEE FIGURE 10)

5.4.1. OPERATION

Operation identical to that of **figure 8**, as described in section 5.2 with control of drainage assured by the air valve **PV4** instead of the manually operated valve **V2**.

The 3-way air valve **PV5** at the atomizer allows the introduction of a product return circuit.

The valve **V4** is a manually operated shut-off valve.

5.4.2. ADVANTAGES

Identical to those described in section 5.2 with the additional possibility of completely automatic cleaning of the paint circuit, with consequent advantages of speed of operation and elimination of errors.

5.4.3. DISADVANTAGES

Increased length of paint circuit to be cleaned and consequently greater loss of product and solvent.

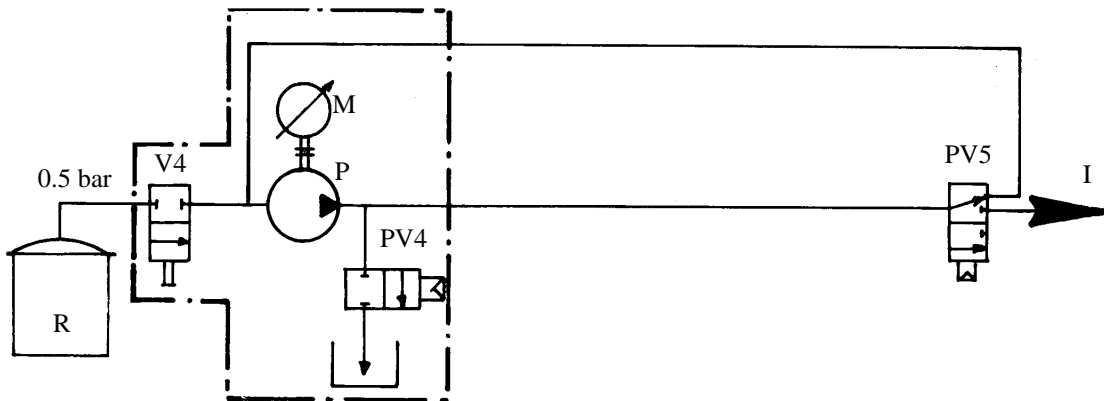

Figure 10

6. ASSEMBLY OF THE SPEED REGULATOR

6.1. REGULATOR; TYPE 431 (SEE SECTION 4.4)

The speed regulator is made up of a printed board equipped with all the regulation material. On one end of the board there is a male conductor and at the other and all the adjustment potentiometers are aligned.

A female connector board guide with locking receives the regulator board.
Connection is done with the screw terminals.

It is strongly advised to attach this connector against a vertical wall so that the printed board is presented with the vertical slice facing the operator.

Futhermore, one must be careful that the air circulation is not vertically affected along the length of the board.

In order not to interfere with the electronic components, one must not place the regulator near any source of heat, and to benefit from the nominal power of the apparatus, the atmospheric temperature must not exceed 45 °C (113 °F) in the enclosure where the equipment is placed.

6.2. REGULATOR, TYPE 432 (SEE SECTION 4.5)

This regulator is completely fitted in its case.

Electrical connections are made directly on the terminal strip to be found on the board.

Make connections as indicated on diagram section 4.5.

7. CONNECTING CABLES

- Speed regulator - direct current motor connection:

5 x 1,2 mm² cable - Insulation: 750 V.

- Speed regulator - speed adjustment potentiometer connection:

3 x 1 mm² cable - Insulation: 500 V.

- Speed regulator - mains connection:

3 x 1,5 mm² cable - Insulation: 750 V.

8. ELECTRICAL CONNECTIONS

8.1. REGULATOR; TYPE 431 (SEE SECTION 4.4)

8.1.1.CONNECTION OF A DC MOTOR

The DC motor armature (Item **A** and **B**) is connected to terminals **9** and **10** of the regulator.

The inductor (Item **I** and **K**) is connected to terminals **7** and **8** of the regulator.

Inversion of the rotation sense: Inversion of the rotation sense is done by inverting the poles of the armature.

Wait till the motor has stopped to inverse the wires.

Work on **9** and **10** or **A** and **B**.

8.1.2.CONNECTING THE SPEED ADJUSTMENT POTENTIOMETER

This potentiometer is connected to terminals **11**, **12** and **13** of the regulator. Terminal **12** is connected to the cursor of the potentiometer.

The other terminals are connected so as to permit an increase in the speed of the motor by rotation of the potentiometer to the right.

If the potentiometer is seen, on the terminal side, one must connect the outside left socket to terminal **13** and outside right socket to terminal **11**.

8.1.3.CONNECTING TO THE NETWORK

Connection to the single phase 220 - 240 V - 50/60 Hz network is done with terminals **4** and **6**.

The ground wire is connected to the ground terminal of the regulator.

Coupling of the ground wire with a supply terminal is not admitted.

The power necessary to supply the regulator is 350 W.

8.2. REGULATOR, TYPE 432 (SEE § 4.5)

For the regulator type 432, see § 6.2 as well as connecting diagram § 4.5.

Use the connecting cables defined in § 7.

9. START-UP

9.1. PAINT PUMP

Before start-up, it is imperative to connect the supply station to a tank of product under pressure or to a pressurized paint line.

This connection is absolutely essential; a volumetric pump must never be run "dry" above all during the first hours of use, when the presence of the product is important for lubrication of the pump gears and bearings.

The product must be fed to the pump at a pressure of about 0.5 bar.

In the case of a pressurized container, adjust the air pressure of the container to this value.

If a pressurized paint line supply is used, a pressure regulator adapted to the paint and adjusted to about 0.5 bar should be placed between the circulating system and the pump.

Pressure of the product in the pump supply circuit must be sufficient to fill up the pump, as this type of pump is unable to produce sufficient depression in the supply circuit to ensure a flow adequate for the calibre and speed of the pump.

However, if the pressure is too high (more than about 1 bar) there is a risk of paint flow through the pump after stoppage, especially with a worn pump.

So that the running-in of the pump is carried out under the best possible conditions, the rotation speed of the pump should be kept at a low value for several hours after start-up. During this period and for the same reason, the use of an abrasive or metallic pigment product should be avoided.

If a leakage of product should appear at the stuffing-box, tighten the stuffing-box nut little by little (by a fraction of a turn each time) until the leak disappears.

This stuffing-box nut should never be tightened too far - on the one hand this would cause over-heating of the driving shaft, on the other would give rise to an excessive driving torque with fall in pump rotation speed.

If the variator-reducer is correctly adjusted, an abnormally high couple or jamming of the pump rotation stops the motor, but the max current of the speed regulator remains set at the maximum value fixed during start-up adjustment.

Special attention must be paid to adjustment of the speed regulator, especially to the maximum current, in order to avoid damaging the equipment.

9.2. SPEED REGULATOR

These units are subject to quality control before delivery, and depending on the type of motor for which they are intended, the following adjustments are made:

- adjustment of minimum on load speed,
- adjustment of maximum on load speed,
- adjustment of maximum current output,
- adjustment of torque compensation,
- adjustment of start-up time.

In the case of the regulator functioning abnormally, or after standard exchange of the printed circuit board, these adjustments should be made again.

9.2.1. PRELIMINARY CHECKS

- Check that the electric bridge of the diagram is well made (between terminals 17 and 18 for the regulator, type **431** (see section 4.4) and between terminals 19 and 20 for the regulator, type **432** (see section 4.5)).
- Check that the mains voltage applied is well within the range 220 to 240 V - frequency 50 or 60 Hz.

9.2.2. ADJUSTMENT OF CURRENT SUPPLY

- Turn the potentiometers “**I max**”, “**Ti**”, “**n min**”, “**n max**”, and “**speed adjustment potentiometer**” as far to the left as possible.
- Connect an electromagnetic ammeter to the induced circuit.
- Block the motor driving shaft or disconnect the excitation circuit (terminals 7 and 8 for the regulator, type **431**, or terminals 8 and 9 for the regulator, type **432**).
- Switch on the variator and place the “**speed adjustment potentiometer**” in the central position. Turn the potentiometer “**I max**” towards the right until a current output of 1.1 A is obtained (direct current).

9.2.3. ADJUSTMENT OF MAX AND MIN SPEEDS

- Connect the excitation circuit (terminals 7 and 8 for the regulator, type **431**, or terminals 8 and 9 for the regulator, type **432**). Turn the “**speed adjustment potentiometer**” to zero. Switch on the variator.

Minimum speed

- Turning the potentiometer “**n min**” towards the right starts up the motor. Adjust the potentiometer so as to slightly exceed this start-up speed.

Maximum speed

The “**speed adjustment potentiometer**” is set at max by turning as far to the right as possible.

The maximum speed can be increased by turning the potentiometer “**n max**” towards the right.

The maximum authorised speed for this motor is 3000 rpm; there are two ways of controlling this speed:

- by direct measurement of the rotation speed of the motor, using a tachometer at the end of the driving shaft behind the motor,
- by checking the induced voltage - a voltmeter is connected to terminals 9 and 10 of the regulator, type **431** (or 10 and 11 of the regulator, type **432**), and a speed of 3,000 rpm is obtained when the voltmeter indicates a steady voltage of 180 V.

9.2.4.ADJUSTMENT OF TORQUE COMPENSATION

Speed stability is adjusted by the potentiometer "I x R". The adjustment is carried out at the slowest operating speed, by finding the point of least variation in speed between on-load and no-load operation.

The compensation should be checked at maximum operating speed.

Over-compensation results in unsteady running.

9.2.5.ADJUSTMENT OF START-UP TIME

speed gradient is adjustable within the range 1-10 seconds by a potentiometer "Ti".

The "Ti". Slight turning of "Ti" adjusts start-up time by 1 or 2 seconds.

10.DISMANTLING OF THE PUMP

Dismantling of a pump may be necessary if rotation becomes blocked.

This jamming of the pump is often caused by one of the following factors:

- deposit or drying of paint in the consecutive gearings after prolonged stoppage or faulty maintenance,
- binding of the sides of the gears and the cheeks of the pump body - this may occur if the pump is run "dry", or for prolonged periods with a non lubricant solvent or with some kinds of metallic paints,
- successive use of two incompatible paints, with insufficient or inadequate rinsing between the two operations.

10.1.DISMANTLING OF GEARS

- Unscrew the locking screws of the coupling on the pump shaft.
- Loosen the stuffing-box nut.
- Using a scribe, make a diagonal position mark on the sides of the pump plates, so that the plates can be re-assembled the correct way round.
- Unscrew and remove the screws holding together the 3 plates and the pump cover.
- Dismantle the cover and the next two plates.
- Remove the lower gear which slides against the secondary shaft.
- Remove the upper gear. This operation is more difficult owing to the presence of the driving pins placed inside the gear, so that the driving shaft must be removed at the same time as the gear. If difficulty is found in removing the gear shaft assembly, it is preferable to separate the pump from its support after completely disconnecting the paint circuits.
- Remove the driving shaft by hammering against the stuffing-box end, using a piece of wood or plastic to prevent deformation of the shaft.
- Soak the disassembled parts in a solvent appropriate to the product used.
- Carefully clean the pump body with solvent, paying special attention to the bearings and the paint supply inlets and outlets.
- Remove all traces of paint from the gears and plates, trying not to jar the parts during this operation.
- After drying, coat the parts with pure vaseline oil. Re-assemble the parts according to the position marks traced on the plates.
- Before finally tightening the 4 screws holding together the plates, rotate the driving shaft by hand
- Tighten the stuffing-box as far as possible while still being able to rotate the driving shaft by hand.

10.2.REPAIR THE PUMP AFTER SEIZURE

- Disassemble the gears and look along the sides of the gears and the plates for the deposit of matter causing the jamming of the pump.
- Remove by scraping, the particles or scratches causing the problem, and finish off the job with a fine-grained whetstone. Reassemble the parts of the pump, following the instructions for reassembly given in the previous section
- Put the pump back into position on the paint supply station, and connect the pump outlet to the pump inlet by means of a length of hose fitting connections. Before closing the circuit thus produced, fill the hose with standard machine lubricating oil. Run the pump with this closed circuit for several hours, at the minimum variator-reducer speed. At the end of this time, check that no further difficulties remain restricting pump rotation. If problems remain, open the oil circulation circuit and re-collect the oil by running the pump.
- Mix with this recovered oil a few grammes of extra-fine abrasive paste (for example, that used for reseating motor valves).
- Stir well to produce a homogeneous mixture.
- Replace this mixture in the oil circulation hose, close the circuit and run the pump for about a quarter of an hour.
- Remove the oil circulation circuit and completely disassemble the pump.
- Clean all the pump parts with solvent, including the bearings, the product inlets and outlets, and the stuffing-box seal. It is a good idea to replace the stuffing-box packing, as the teflon wool may retain grains of the abrasive paste. About 4 grammes of teflon wool is required for the packing.
- Before reassembly, coat all moving parts with pure vaseline oil.
- The repaired pump should now operate normally.

11.MAINTENANCE

11.1.MOTOR

- Ball bearings greased "for life" during manufacture .
- Dust removal at regular intervals (frequency depending on environmental conditions) is desirable to maintain good ventilation.
- Regular changing of the brushes. It is virtually impossible to give a valid estimate of the life-span of a pair of brushes, as this varies greatly with use and environmental conditions. However, as a general guide, replacement of the brushes every 1,000 hours can be considered reasonable. After changing the brushes 3 times, it is necessary to disassemble the motor and turn the collector on the lathe so as to produce an even surface for contact against the brushes. After this operation, make sure that the insulating blocks between the blades of the collector do not protrude beyond the blades, which would impede contact with the brushes. Finish off the machine tooling of the collector using a very fine-grained whetstone.

11.2.SPEED REDUCER

- The reducer is delivered lubricated ready for use.
- Lubrication must take place every 8,000 hours.
- Use a grade zero extreme pressure grease.

11.3. PAINT PUMP

11.3.1. MAINTENANCE OF THE PAINT CIRCUIT

It is strongly advised that, for each prolonged stop, complete rinsing of the gearing pump with thick solvent (naphta), or solvent compatible with the paint used, should be carried out.

Rinsing of the paint circuit is made easier by using pump by-pass, controlled either by a manually operated valve, or by an air valve.

This by-pass allows the solvent to circulate rapidly through the paint distribution circuit, thus combining the mechanical action of speed of flow with the chemical action of the solvent.

In addition, the by-pass permits rinsing of the paint circuit to be carried out in a relatively short time, this being a function of the fall in pressure along the paint circuit and the initial pressure of the rinsing solvent.

Rinsing of the pump should be carried out by running the pump at a low speed during the last moments of the cleaning operation, so that the smallest possible amount of solvent is passed through the gears. The pump should be allowed to run for just sufficient time to assure cleaning of the section of circuit between the beginning and end of the pump by-pass.

Rinsing of the paint circuit and the pump is made much easier if a hose-cleaning pressurized tank is used, which injects small quantities of solvent and air simultaneously into the circuit to be cleaned.

This alternation of products causes turbulence in the circuit, increasing the mechanical action of the rinsing solvent; the amount of solvent used for the cleaning operation can thus be reduced by a factor from 5 to 1.

This hose cleaning hopper can be supplied upon demand for 10 to 45 litres capacities.

After complete rinsing of the circuit, there are two possibilities:

Stop of less than 3 days:

Leave the solvent in the whole paint circuit previously cleaned.

Stop of more than 3 days:

After rinsing of the paint circuit, replace the pressurized solvent supply by a supply of compressed air so as to force out all solvent remaining in the circuit.

Do not leave the pump running during this operation.

The compressed air supply can be obtained by separate connection to a compressed air circuit, or by removing the internal container of the solvent tank and using this pressurized tank without product.

11.3.2. START-UP AFTER CIRCUIT RINSING

Connect the paint distribution circuit to a product supply, pressurized tank or paint line; then open the pump by-pass.

When the paint begins to flow at the other end of the distribution circuit, start-up the pump at a low speed.

Leave the pump running at this reduced speed for a few seconds before operating at normal speed.

11.3.3. MECHANICAL MAINTENANCE

Watch the stuffing-box sealing the pump driving shaft. If a leak appears here, tighten the stuffing-box nut by fractions of a turn until the leak stops.

If this procedure does not stop the leak effectively, unscrew the stuffing-box completely and replace the teflon wool packing.

12. TROUBLE SHOOTING

SYMPTOMS	PROBABLE CAUSES	REMEDIES
- Paint pump not turning	- Stuffing-box too tight.	- Loosen the stuffing-box sealing, then check by hand that rotation is possible.
	- Electric motor not turning.	- See below.
	- Pump jammed.	- Disassemble the pump according to the instructions given in section 10 "Dismantling of the pump".
- Pump input shaft turning, but no output.	- Driving pin of pump motor gear broken.	- Disassemble the pump and change the pin. - Check the general condition of the pump to find the reason for the pin breaking.
- Motor not turning.	- Motor not supplied correctly by the speed regulator.	- Check the voltage at the inductor terminals - normal d.c. voltage 200 V. - Check the voltage at the induced circuit terminals. By turning the "speed adjustment potentiometer", voltage adjustable from 7 to 180 V d.c. - If the voltage is incorrect, reset the adjustments as described in section 9.2. If the required settings cannot be obtained, refer to symptom "defective regulator" below.
	- Electrical connections broken.	- Check condition of connections and connecting cables.
	- Brushes worn out.	- Replace the brushes - refer to section 11.1 "motor maintenance".
- Defective regulator.	- Incorrect low voltage supply to regulator.	- Check that the voltage at the feed terminals is between 220 and 270 V.
	- Break in the speed adjustment circuit.	- Check the continuity of the circuit with an ohmmeter, changing the position of the cursor along the whole range of adjustment.
	- Fuses in bad condition.	- Replace fuses FF 6,3A. - Check all circuits to find the cause of the damage.
	- No clearly defined cause.	- Replace the printed circuit board, following the instructions given in section 9.2.
- Leakage at the pump stuffing-box.	- Faulty tightening, or worn stuffing-box packing.	- Readjust the tightening of the stuffing-box, or change the packing. Refer to section 11.3.3 "mechanical maintenance of the pump".

For all other problems, please consult **BINKS-SAMES** technical services.

13.ENAMEL SUPPLY STATIONS CTH 301 - CTH 302

The enamel supply stations **CTH 301 - CTH 302** are similar to the paint supply stations **CPH 301 - CPH 302**; the present instruction manual is equally applicable, with the exception that the pumps are different.

The enamel supply stations **CTH 301** and **CTH 302** are fitted with “**DOSEMAIL**” worm reduction pumps (hose crushed by rotating rollers) designed to carry abrasive (but not chemically aggressive) products, in particular vitreous enamel.

The product, contained in a pressurized tank placed on an insulating support, is led directly to the “**DOSEMAIL**” pump. In order to avoid over-pressurizations due to possible clogging-up of a sprayer nozzle, a security sleeve is fitted to the outlet connection of each “**DOSEMAIL**” pump

13.1.MAINTENANCE

Before start-up:

- With the pump axis vertical and at the bottom, unscrew the 4 hollow hexagonal screws and remove the rear cheek; then put 20 cc of SAE 40 motor oil into the pump body.
- Change the hose every 100 hours as a precaution.
- Grease the needle rollers every 500 hours.

If enamel should get into the active part of the pump, send oil through.

IMPORTANT : never run a pump without oil.

13.2.DISMANTLING OF THE “DOSEMAIL” PUMP (SEE FIGURE 11)

Replacement of the ball-bearings:

- Remove the protection cover **5A** (3 hexagonal hollow screws 6 x 15 **5B**).
- Unscrew and remove the counter-nut **5C** (22 spanner) holding nut **5D** (22 spanner).
- Unscrew and remove nut **5D**.
- Remove the NILOS ring **5E**.
- Remove the closing cheek **5F** (4 hexagonal hollow screws 6 x 25 **5G**).
- Dismantle the outlet strip **5H** (4 hexagonal hollow screws 6 x 15 **5I**) and remove the strip-hose assembly vertically, freeing it from the rollers.
- Carefully hit the end of shaft **5J** to free it from the bearing **5K2** (ideally removing it with a press).
- Extract bearing **5K2** from the pump body.

Replacement of the hose:

- Remove the closing cheek **5F** (4 hexagonal hollow screws 6 x 25 **5G**).
- Dismantle the outlet strip **5H** and take out the strip-hose assembly vertically, freeing it from the rollers.
- Unscrew the two hose stop nuts **5M**.
- Free the hose from the 2 ridged end-piece **5N1** and **5N2** and replace (6 x 12 hose, length 230 mm).
- Reassemble by carrying out the above operations in reverse order, first carefully cleaning the pump body and not forgetting to top up with oil.

Be particularly careful:

- not to twist the hose,
- not to leave any enamel in the pump body.

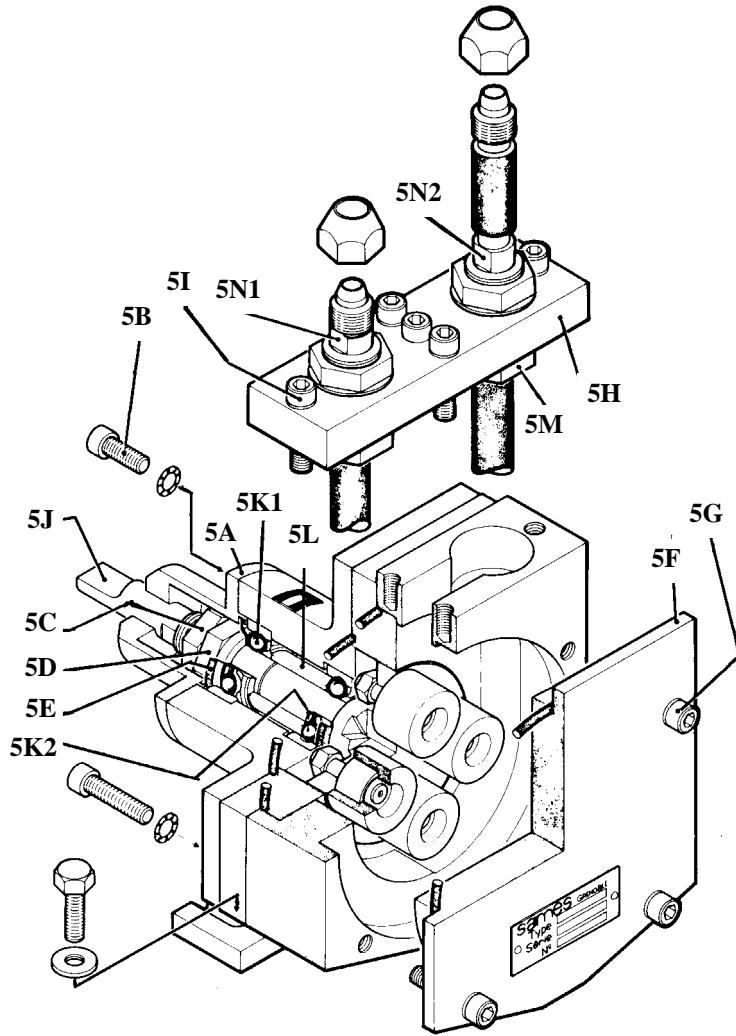

Figure 11

14.SPARE PARTS

ID01-A - SPARE PARTS CPV 201 - CPH 301/CPH 302

Item	Article code	Description	Qty	Sales unit
		PUMP		
	J3T RUL 002	Stuffing-box packing (250 g)	1	1
	Y1P CDL 026	Pump 0.6 cm ³ /tr	1	1
	Y1P CDL 028	Pump 1.2 cm ³ /tr	1	1
	Y1P CDL 030	Pump 2.4 cm ³ /tr	1	1
	Y1P CDL 036	Pump 3 cm ³ /tr	1	1
	Y1P CDL 037	Pump 6 cm ³ /tr	1	1
	J3T TCN 005	Seal for the short circuit tap of the pump	2	2

		VARIATOR-REDUCER		
	K1V HRZ 003	Variator-reducer	1	1
	K1V BAL 008	Brushes 6.3 x 12.5	2	4
	K6R KBR 105	Bearing 15 x 35 x 11	1	1
	K6R KBR 103	Bearing 12 x 32 x 10	1	1

		SPEED REGULATOR		
	E6F CFN 084	Rapide-action fuse FF 6.3 A	2	5
	E7P FAD 028	Speed adjustment potentiometer 10 k Ω	1	1
	K1V REG 004	Printed circuit board, regulator type 431	1	1
	K1V REG 005	Connector for printed circuit board, type 431	1	1
	K1V REG 006	Speed regulator (with box) type 432 G	1	1
	K1V REG 007	Printed circuit board, regulator type 432	1	1

		INSULATING TRANSMISSION SHAFT (for insulated type supply station)		
	454 667	Insulated shaft with motor coupling	1	1

		FLEXIBLE COUPLING (for earthed type supply station)		
	454 669	Coupling	1	1

ID02-A - DOSEMAIL PUMP

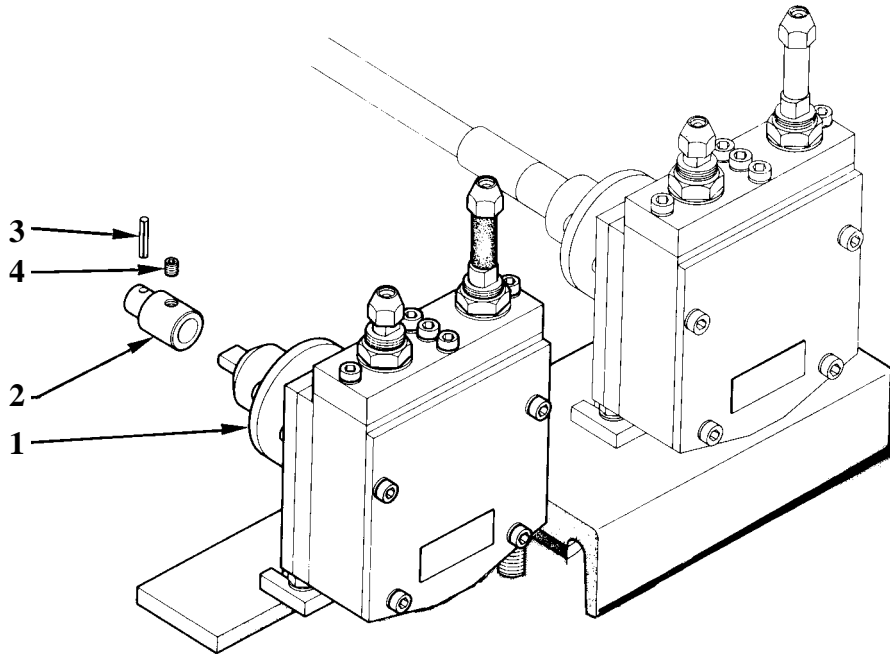

Item	Article code	Description	Qty	Sales unit
1	202 376	DOSEMAIL pump	1	1
2	441 587	Coupling on pump	1	1
3	X3D GMC 123	Pin 4 x 20	1	1
4	X3A SSC 686	Cup end Hc screw 6 x 6	1	1

ID03-01-A - DOSEMAIL PUMP SUPPORT

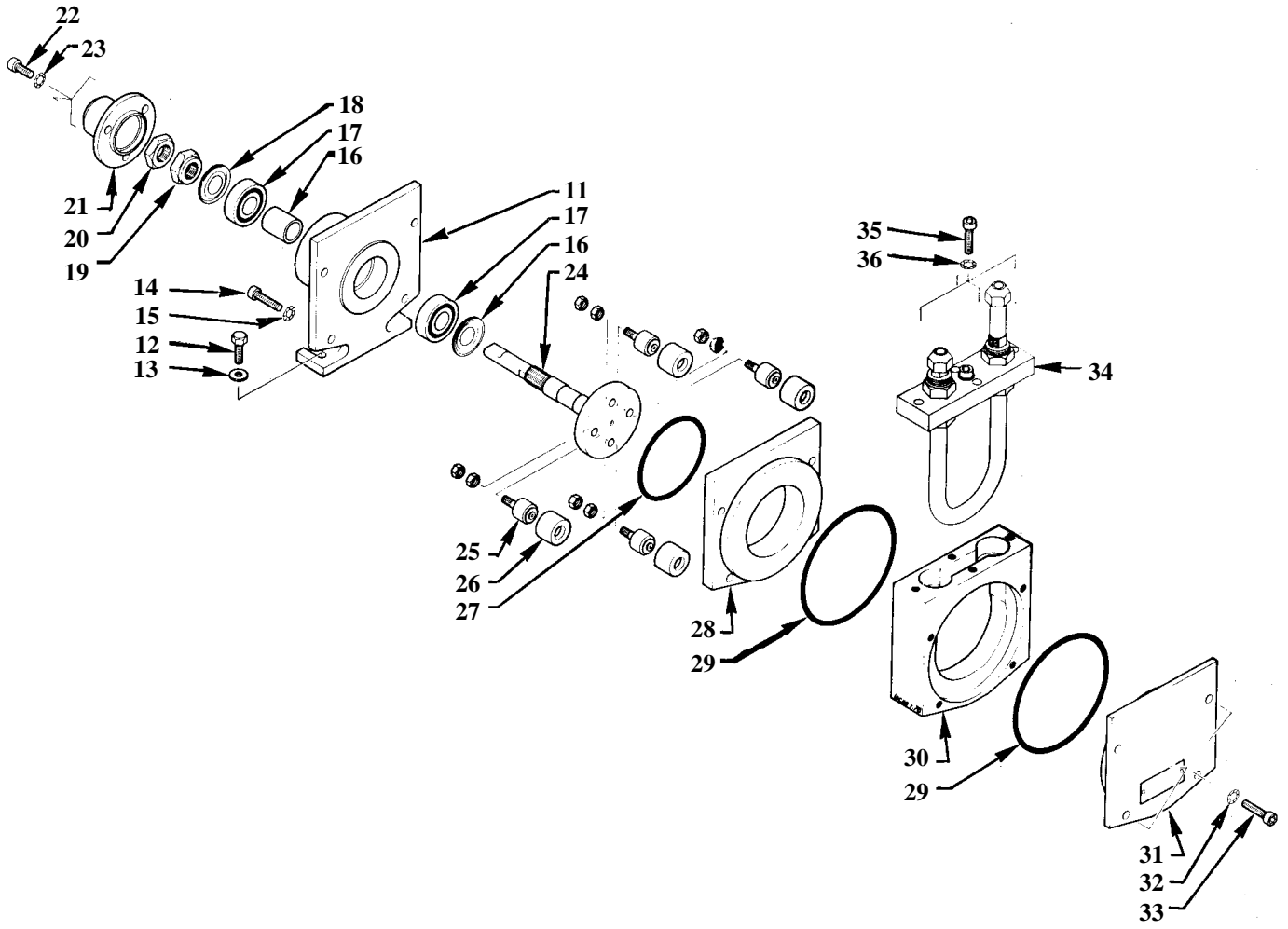

ID03-02-A - DOSEMAIL PUMP SUPPORT

Item	Article code	Description	Qty	Sales unit
11	314 514	Enamel pump support stage	1	
12	314 530	Pump fixation screw H M 6 x 20	2	
13	314 531	Pump fixation washer	2	
14	X3A VSY 227	Screw CHc M 6 x 25	4	
15	X2B DVX 006	Toothed washer Diam. 6 mm	4	
16	314 527	Bearing cross-piece	1	
17	K6R KBR 106	Bearing 15 x 35 x 11	2	
18	K6G BET 069	Hermeticity ring	2	
19	314 523	Enamel pump rotor nut M 14 x 100	1	
20	314 524	Rotor counter-nut M 14 x 100	1	
21	314 526	Protection cage	1	
22	X3A VSY 223	Screw CHc M 6 x 16	3	
23	X2B DVX 006	Toothed washer Diam. 6 mm	3	
24	314 518	Enamel pump rotor	1	
25	K6R DGA 120	Roller with greaser and nuts	4	
26	314 521	Roller sleeve	4	
27	J2C TCN 133	O-ring 66.2 / 2.5	1	
28	314 515	Intermediate cheek	1	
29	J2C TCN 168	O-ring 88 / 2.5	2	
30	314 516	Enamel pump body	1	
31	314 517	Closing cheek	1	
32	X2B DVX 006	Toothed washer Diam. 6 mm	4	
33	X3A VSY 227	Screw CHc M 6 x 25	4	
34	203 287	Fitted pumping element (see plate ID03-03)	1	
35	X3A VSY 223	Screw CHc M 6 x 16	4	
36	X2B DVX 006	Toothed washer Diam. 6 mm	4	

ID03-03-A - DOSEMAIL PUMP SUPPORT

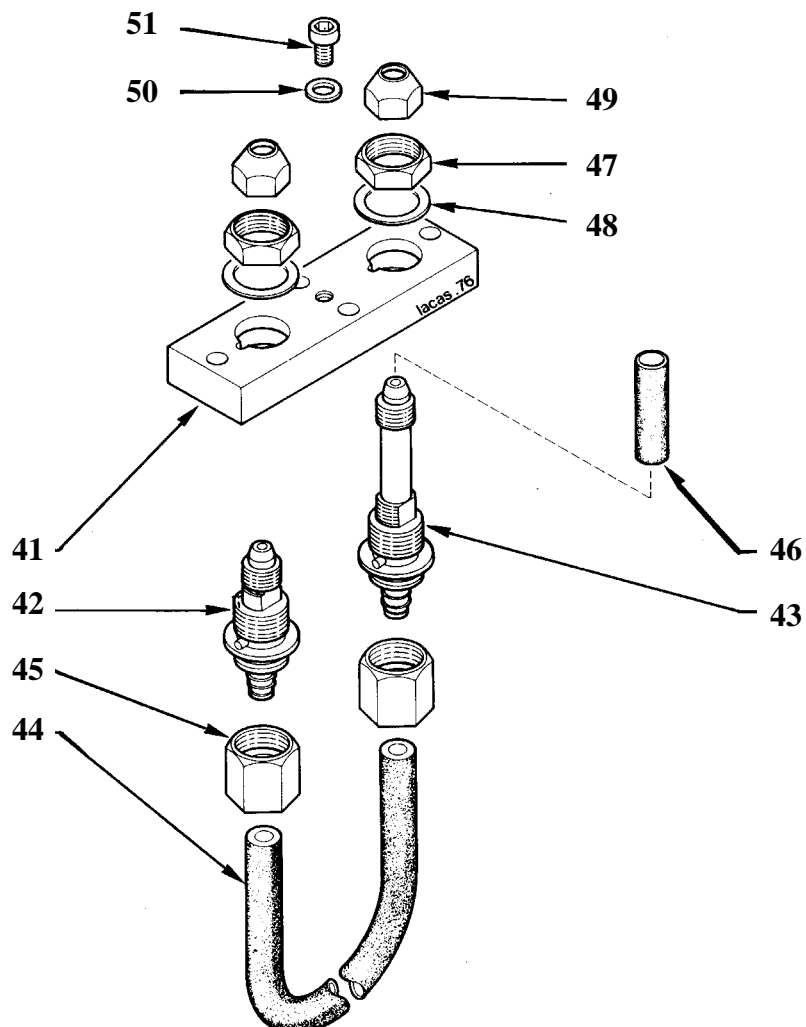

Item	Article code	Description	Qty	Sales unit
41	314 519	Strip	1	1
42	314 520	Inlet end-piece	1	1
43	314 528	End piece with valve	1	1
44	J2N TUY 038	Hose, 6 x 12	0.23	m
45	314 529	Hose stop nut	2	1
46	J2N TUY 034	Neoprene hose 8 x 11	0.04	m
47	314 525	Nut M 8 x 150	2	1
48	314 522	Washer	2	1
49	314 567	Connection nut	2	1
50	X2F DMU 006	Flat washer	1	1
51	X3A VSY 221	Screw CHc M 6 x 10	1	1

ID04-A - DISTRIBUTOR SUPPORT ASS'Y

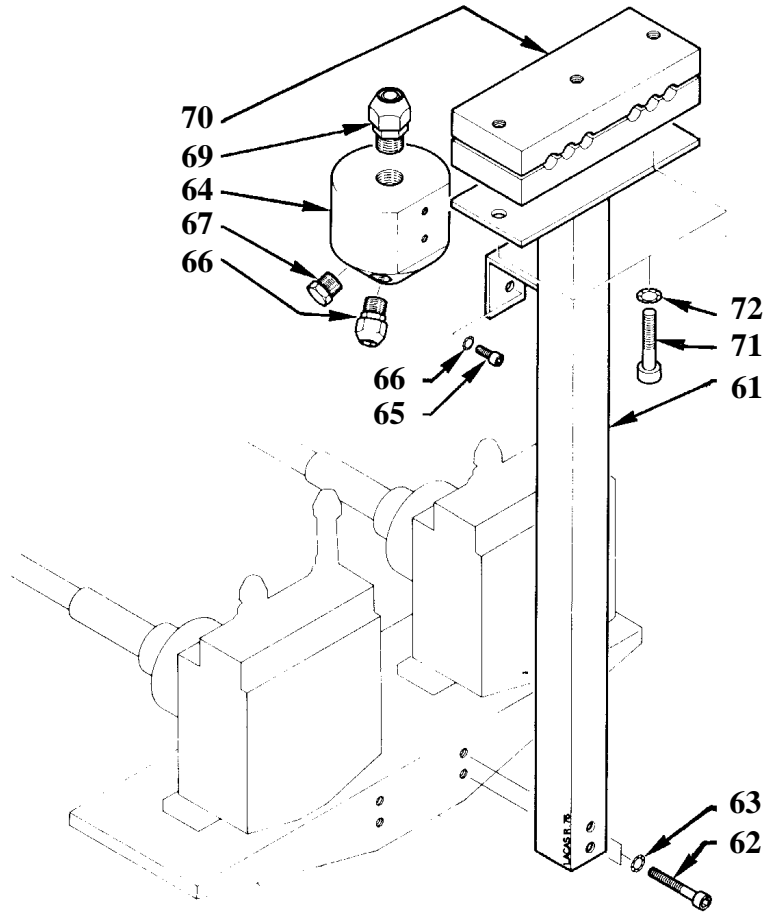

Item	Article code	Description	Qty	Sales unit
61	441 803	Distributor support	1	1
62	X3A VSY 230	Screw CHc M 6 x 40	2	10
63	X2B DVX 006	Toothed washer 6 mm	2	10
64	316 304	6-outlet enamel distributor	1	1
65	X3A VSY 182	Screw CHc M 5 x 12	2	10
66	X2B DVX 005	Toothed washer 5 mm	2	10
67	F6R LBH 004	Male stopper 1/4"	5	10
68	F6R LUF 171	Male coupling 7.5/10 - 1/4"	6	10
69	F6R LUF 173	Male coupling 11/14 - 3/8"	1	10
70	314 775	6 passage hose support	1	1
71	X3A VSY 287	Screw CHc M 8 x 40	2	10
72	X2B DMU 008	Toothed washer Diam. 8 mm	2	10