

From February 1st, 2017 SAMES Technologies SAS becomes SAMES KREMLIN SAS
A partir du 1/02/17, SAMES Technologies SAS devient SAMES KREMLIN SAS

SAMES  **KREMLIN**

 **Sames**



User manual

EC 35, 50 65, 80 Magnetic Bellcups and Shaping air assemblies

FRANCE **SAS SAMES Technologies.** 13 Chemin de Malacher 38243 Meylan Cedex
Tel. 33 (0)4 76 41 60 60 - Fax. 33 (0)4 76 41 60 90 - www.sames.com
USA **Exel North America.** 45001 5 Mile Road, Plimouth, Michigan, 48 170
Tel. (734) 979-0100 - Fax. (734) 927-0064 - www.sames.com

All communication or reproduction of this document, in any form whatsoever and all use or communication of its contents are forbidden without express written authorisation from SAMES Technologies.

The descriptions and characteristics mentioned in this document are subject to change without prior notice.

© SAMES Technologies 2001



WARNING : SAS Sames Technologies is registered with the Ministry of Labour as a training institution.

Throughout the year, our company offers training courses in the operation and maintenance of your equipment.

A catalogue is available on request. Choose from a wide range of courses to acquire the skills or knowledge that is required to match your production requirements and objectives.

Our training courses can be delivered at your site or in the training centre at our Meylan head office.

Training department:

Tel. 33 (0)4 76 41 60 04

E-mail: formation-client@sames.com

SAS Sames Technologies operating manuals are written in French and translated into English, German, Spanish, Italian and Portuguese.

The French version is deemed the official text and Sames will not be liable for the translations into other languages.

EC 35, 50 65, 80
Magnetic Bellcups
and
Shaping air assemblies

1. Recommendations	4
2. Description	4
3. Characteristics	5
4. Specific tools	6
4.1. <i>Using with atomizers, direct charge</i>	6
4.2. <i>Using with atomizers external charge</i>	7
5. Maintenance	8
5.1. <i>Magnetic bellcups</i>	8
5.1.1. <i>Removal</i>	8
5.1.2. <i>Reassembly</i>	9
5.2. <i>Bellcup distributor</i>	10
5.2.1. <i>Disassembly</i>	10
5.2.2. <i>Reassembly</i>	11
5.3. <i>Shaping air assembly</i>	12
5.3.1. <i>Using with direct charge atomizers</i>	12
5.3.2. <i>Using with external charge atomizers</i>	12
6. Spare parts	13
6.1. <i>EC 35 magnetic bellcup</i>	13
6.2. <i>EC 50 magnetic bellcup</i>	14
6.3. <i>EC 65 magnetic bellcups</i>	14
6.4. <i>EC 80 magnetic bellcup</i>	15
6.5. <i>Shaping air assemblies using with direct charge atomizers</i>	16
6.5.1. <i>With EC 35 bellcup , vortex shaping air assembly</i>	16
6.5.2. <i>With EC 50 bellcup , vortex shaping air assembly</i>	17
6.5.3. <i>With EC 65 bellcups, vortex shaping air assembly</i>	18
6.5.4. <i>With EC 80 bellcup, vortex shaping air assembly</i>	19
6.6. <i>Shaping air assemblies using with external charge atomizers</i>	20
6.6.1. <i>With EC 65 bellcup for PPH 308 atomizer, external charge</i>	20
6.6.2. <i>With EC 65 bellcup for PPH 607 atomizer, external charge</i>	20

1. Recommendations

For perfect results, the atomizing bellcup must be cleaned frequently. It is recommended to clean the bellcup external every 8 hours and completely every 120 hours. The bellcup must not be subjected to impacts on its atomizing edge or distorted.

2. Description

The bellcup is a component which allows the atomizing of liquid materials specially high solid primers, basecoats and clearcoats. It is fixed to the turbine rotor by a magnetic clip.. The EC bellcups can be installed on different atomizers (PPH 607, PPH 707, Accubell 607, PPH605, PPH 308, Aquabell...) with the appropriated shaping air assy.

EC 35 magnetic bellcup

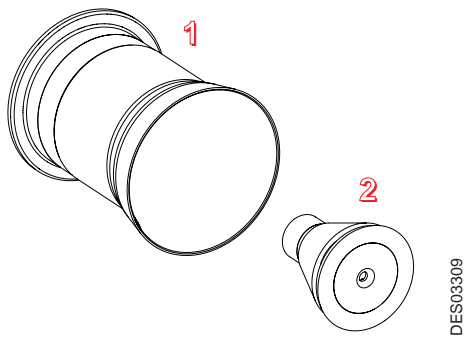

EC 50 magnetic bellcup

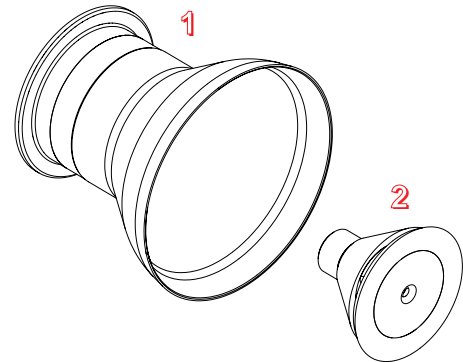

EC 65 magnetic bellcup

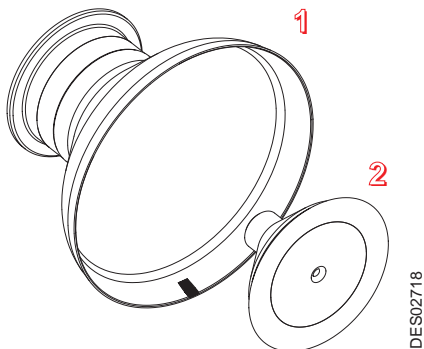

EC 80 magnetic bellcup

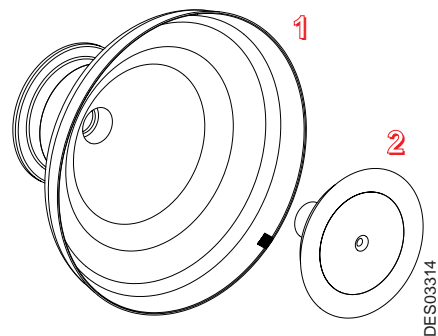

1	Magnetic bellcup
2	Distributor

3. Characteristics

	Diameter	Length	Weight (with distributor)
Aluminium EC 35 magnetic bellcup	35 mm	44 mm	43 g
Aluminium EC 50 magnetic bellcup	50 mm	44 mm	44, 7g
Aluminium EC 65 magnetic bellcup	65 mm	44 mm	52 g
Titanium EC 65 magnetic bellcup	65 mm	44 mm	67 g
Aluminium EC 80 magnetic bellcup	80 mm	44 mm	59,1 g

4. Specific tools

4.1. Using with atomizers, direct charge

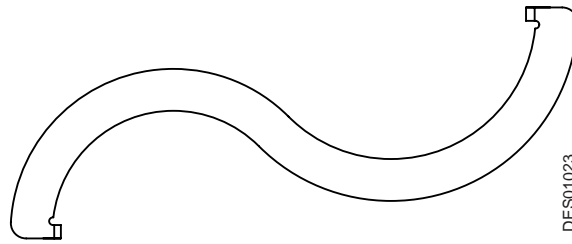

Part number	Description	Qty	Sale unit
1308689	Assembling and disassembling wrench for outer cover	1	1

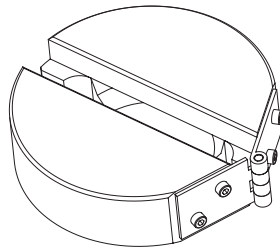

Part number	Description	Qty	Sale unit
900000804	Disassembly tool for EC 35 magnetic bellcup	1	1
900000803	Disassembly tool for EC 50 magnetic bellcup	1	1
1204427	Disassembly tool for EC 65 magnetic bellcup	1	1
1204556	Disassembly tool for EC 80 magnetic bellcup	1	1

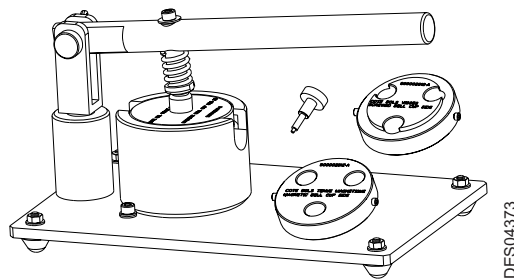

Part number	Description	Qty	Sale unit
910002897	Assembly/Disassembly tool for distributor bell cup	1	1

4.2. Using with atomizers external charge

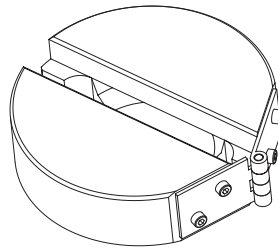

DES04059

Part number	Description	Qty	Sale unit
900003799	Disassembly tool for EC 65 magnetic bellcup	1	1

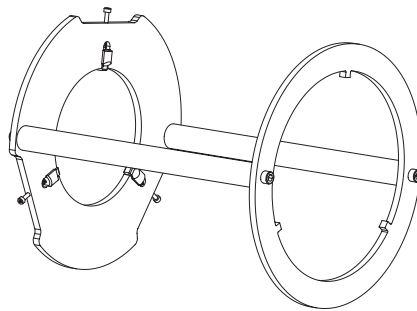

DES04003

Part number	Description	Qty	Sale unit
910005556	Assembling and disassembling tool for outer cover, PPH external charge	1	1

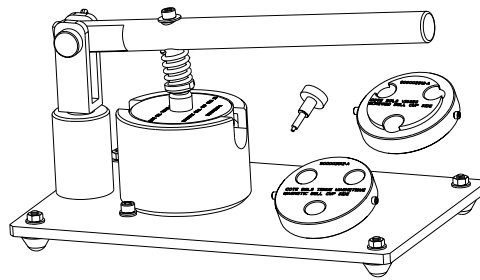

DES04373

Part number	Description	Qty	Sale unit
910002897	Assembly/Disassembly tool for distributor bell cup	1	1

5. Maintenance

5.1. Magnetic bellcups

5.1.1. Removal

- **Step 1:** Position the appropriate tool ([see § 4 page 6](#)) on the outer cover.



WARNING : Attention position correctly the tool on the bellcup. The tool groove must imperatively be side of edge of the bellcup.

- **Step 2:** Close the tool on the bellcup.

- **Step 3:** Hold the tool until it stops and pull the bellcup in the axis.

- **Step 4:** Maintain the tool supporting the bell in order not to let it fall.

- **Step 5:** Place the bellcup on a plane and perfectly clean surface.



Step 1

Step 2



Groove

Step 3



Step 4



WARNING : All maintenance and handling operations operated on the magnetic bellcups must be carried out with the utmost care as they are balanced.

5.1.2. Reassembly



WARNING : Imperatively put in place the shaping air shroud before installing the magnetic bellcup.



WARNING : The magnetic bellcup must be fitted on a turbine type " BTM".



WARNING : Check the absence of foreign matters (residues of dry painting, filings...) on the complete face of support of the bellcup and the rotor (cylinder, flange and magnet).



- Position the magnetic bellcup on the rotor, a snap must be heard.



5.2. Bellcup distributor

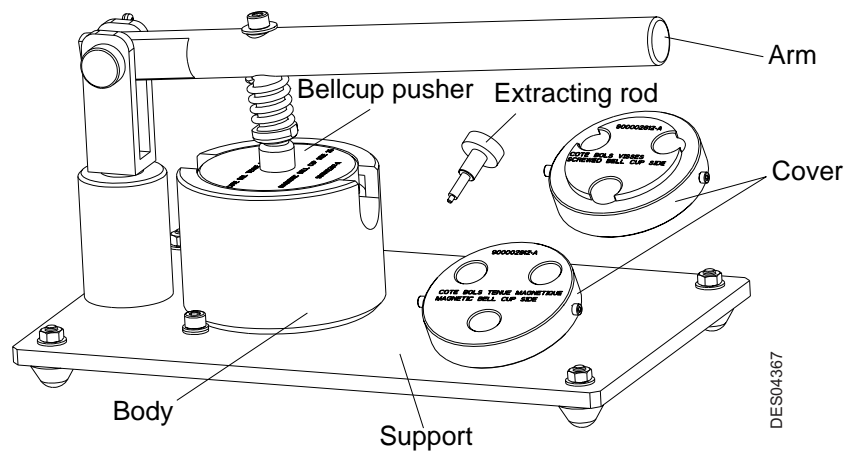

5.2.1. Disassembly

- **Step 1:** Put in place the bellcup in the body. Choose the cover according to the type of the bellcup (screwed or with magnetic fixing). **Remark:** the position of the cover is given by the marking which must be side bellcup.



- **Step 2:** Place the cover on the body and turn it to secure the bellcup.

- **Step 3:** Place the body on the support in stop against the screws, (cover side support). Put in place the extracting rod.

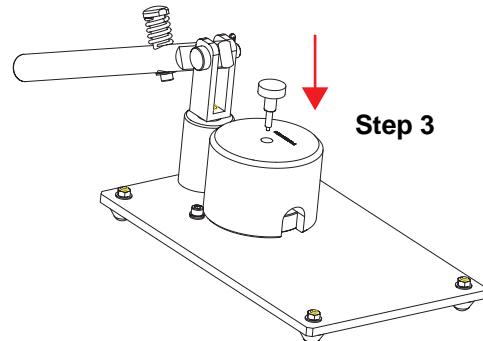

- **Step 4:** Bring the arm on the extracting rod and press until it stops. A "Clac" must be heard, distributor is separated from bellcup.

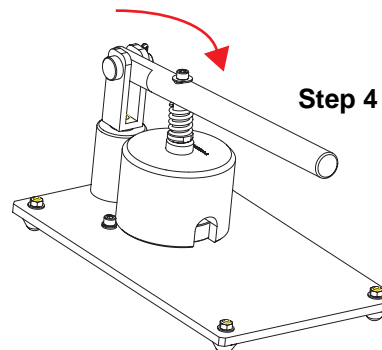

DES04369

5.2.2. Reassembly

- **Step 1:** Manually position the distributor in bellcup.

- **Step 2:** Place bellcup in the tool body.

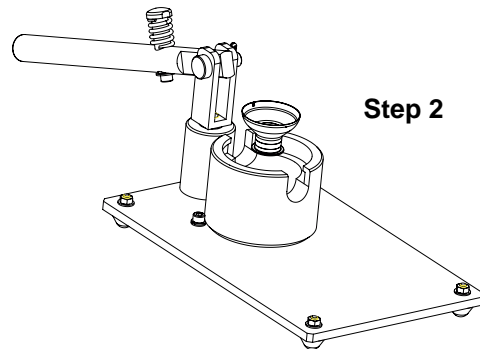

- **Step 3:** Select according to the bellcup diameter, the side of the bellcup pusher. Install the bellcup pusher in the body.

Remark: the position of the cover is given by the marking which must be side bellcup.

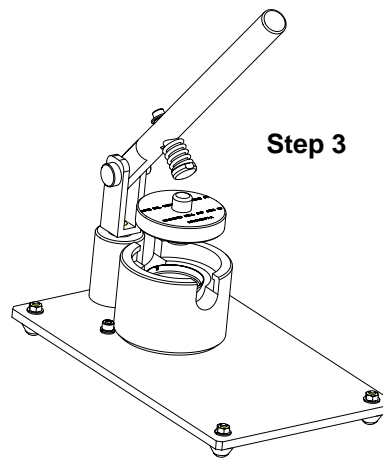

- **Step 4:** Bring the arm on the bellcup pusher and press until complete crushing of the spring. Distributor is then assembled.

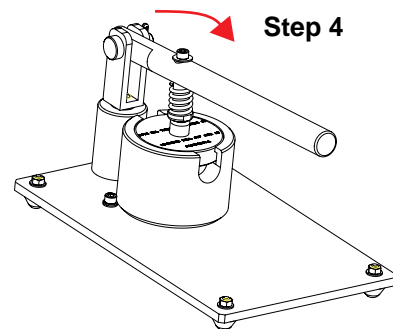

DES04370

5.3. Shaping air assembly

5.3.1. Using with direct charge atomizers

This procedure is identical whatever the diameter of the bellcup and whatever the type of shaping air assemblies.

Removal:

- Switch off high voltage and bearing air supplies.
- Remove the aluminium cover using the tool P/N # 1308689, by placing the wrench notches into the aluminium cover slots, turn clockwise and continue removing by hand.
- Remove the shaping air shroud from the atomizer.

Re-assembly:

- Proceed in reverse order.

5.3.2. Using with external charge atomizers

Removal:

- Switch off high voltage and bearing air supplies.

- Put the tool (P/N 910005556) on the atomizer (the small diameter has to be on the outer cover side). Place the retractable catches of the tool into the aluminium cover slots, unlock the outer cover.

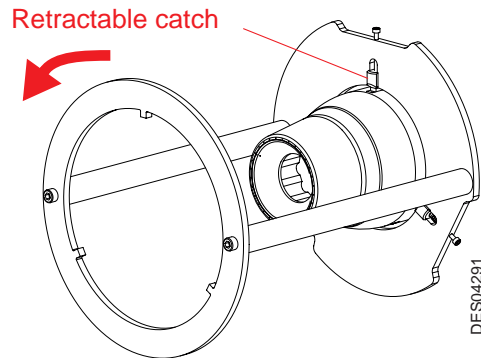

- Continue removing by hand then remove the outer cover.
- Remove manually the shaping air shroud from the atomizer.

Re-assembly:

- Install the shaping air shroud on the atomizer, put in place the outer cover and tighten by hand.
- Lock the outer cover with the tool (P/N 910005556).

6. Spare parts



WARNING : The magnetic bellcups must be assembled on a turbine type "BTM ".



WARNING : Average lifetime of a bellcup and a distributor.

	Clearcoats	Basecoats
Bellcup	5000 hours	5000 hours
Distributor	3000 hours	1500 hours



WARNING : These average values depend of the paint type, of the paint flow and of the bellcup rotation speed.

6.1. EC 35 magnetic bellcup

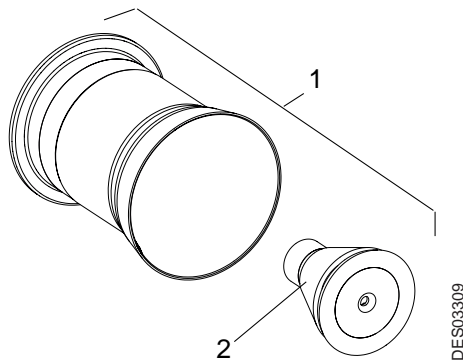

Item	Part number	Description	Qty	Sale unit
1	910000877	EC 35 magnetic bellcup assembly (aluminium)	1	1
2	1312181	Distributor (included in item1)	1	1

6.2. EC 50 magnetic bellcup

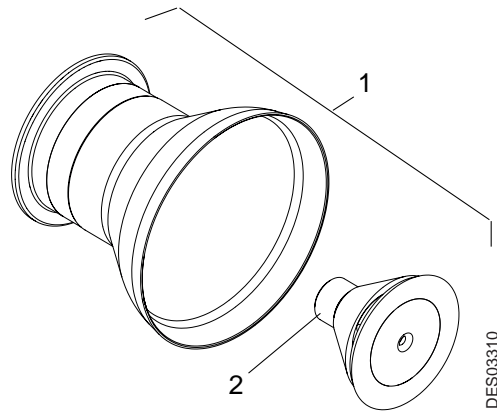

Item	Part number	Description	Qty	Sale unit
1	910000876	EC 50 magnetic bellcup assembly (aluminium)	1	1
2	1312135	Distributor (included in item1)	1	1

6.3. EC 65 magnetic bellcups

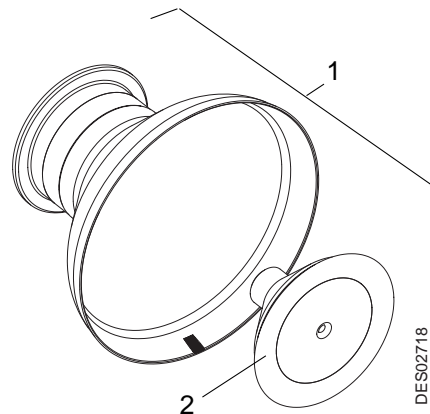

Item	Part number	Description	Qty	Sale unit
1	1527176	EC 65 Magnetic bellcup assembly (aluminium)	1	1
2	1315845	Distributor (included in item1)	1	1
1	910001849	EC 65 Magnetic bellcup assembly (OAC - aluminium)	1	1
2	900001326	Distributor (included in item1)	1	1
1	1527175	EC 65 Magnetic bellcup assembly (titanium)	1	1
2	1314206	Distributor (included in item1)	1	1



WARNING : If solvent born products are used, the magnetic bellcup in titanium can, in the event of collision, generate sparks by frictions.

6.4. EC 80 magnetic bellcup

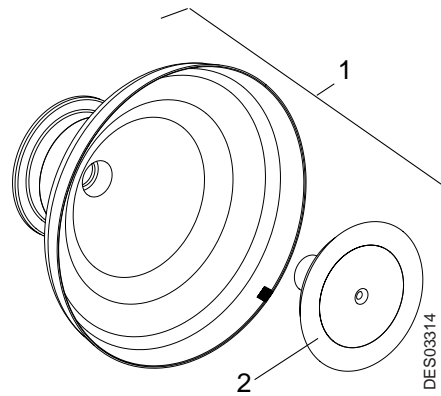

Item	Part number	Description	Qty	Sale unit
1	910000202	EC 80 Magnetic bellcup assembly (aluminium)	1	1
2	1315845	Distributor (included in item1)	1	1

6.5. Shaping air assemblies using with direct charge atomizers

6.5.1. With EC 35 bellcup , vortex shaping air assembly

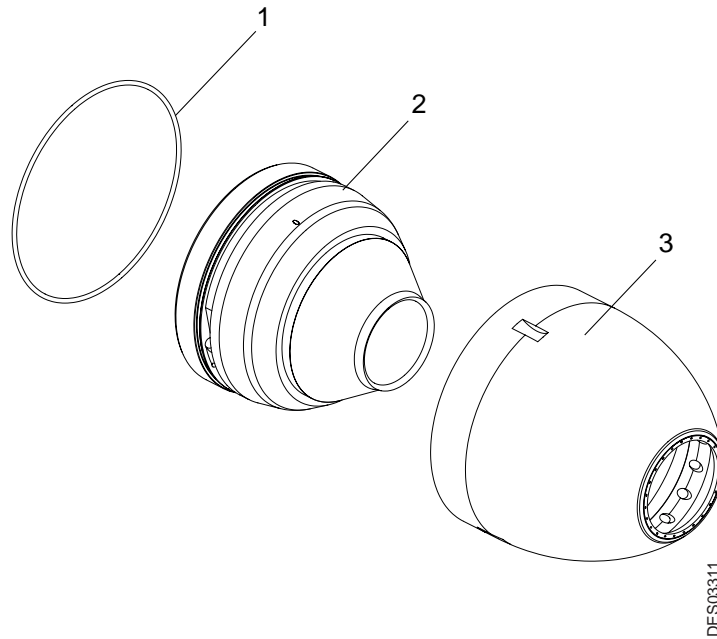

Item	Part number	Description	Qty	Sale unit
	910001297	Vortex shaping air assembly	1	1
1	J2FENV622	O-ring - FEP	1	1
2	900000786	Vortex shaping air shroud - Dia: 35 mm	1	1
3	900000787	Vortex outer cover Dia: 35 mm	1	1

6.5.2. With EC 50 bellcup , vortex shaping air assembly

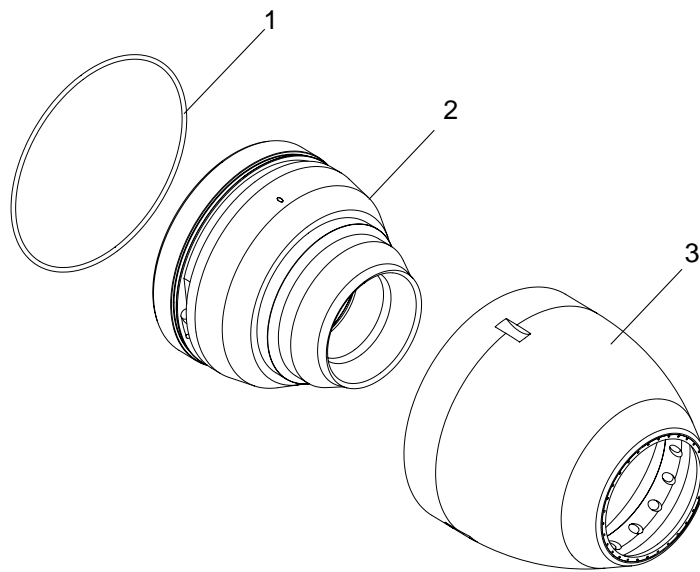

DES03312

Item	Part number	Description	Qty	Sale unit
	910001298	Vortex shaping air assembly	1	1
1	J2FENV622	O-ring - FEP	1	1
2	900000774	Vortex shaping air shroud - Dia: 50 mm	1	1
3	900000775	Vortex outer cover Dia: 50 mm	1	1

6.5.3. With EC 65 bellcaps, vortex shaping air assembly

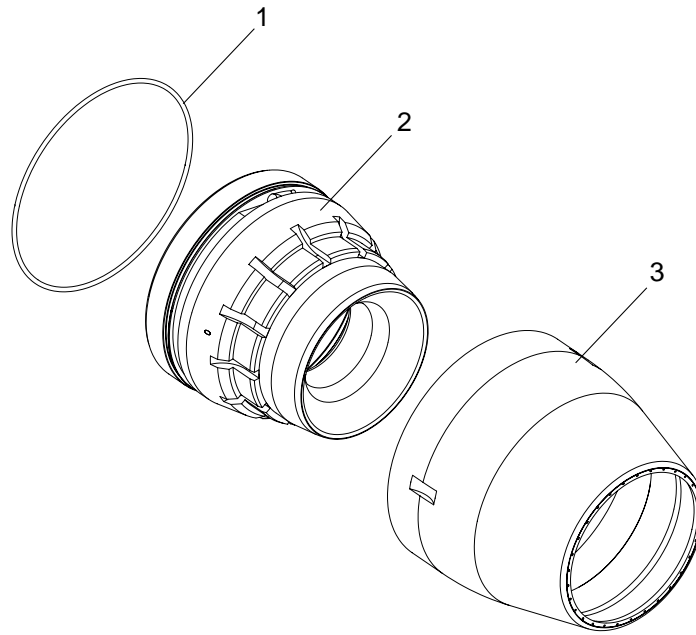

Item	Part number	Description	Qty	Sale unit
	910001196	Vortex shaping air assembly	1	1
1	J2FENV622	O-ring - FEP	1	1
2	1105862	Vortex shaping air shroud - Dia: 65 mm	1	1
3	1105861	Vortex outer cover Dia: 65 mm	1	1

Item	Part number	Description	Qty	Sale unit
	910001695	Straight shaping air assembly	1	1
1	J2FENV622	O-ring - FEP	1	1
2	1105862	Shaping air shroud - Dia: 65 mm	1	1
3	900001955	Straight outer cover Dia: 65 mm	1	1

6.5.4. With EC 80 bellcup, vortex shaping air assembly

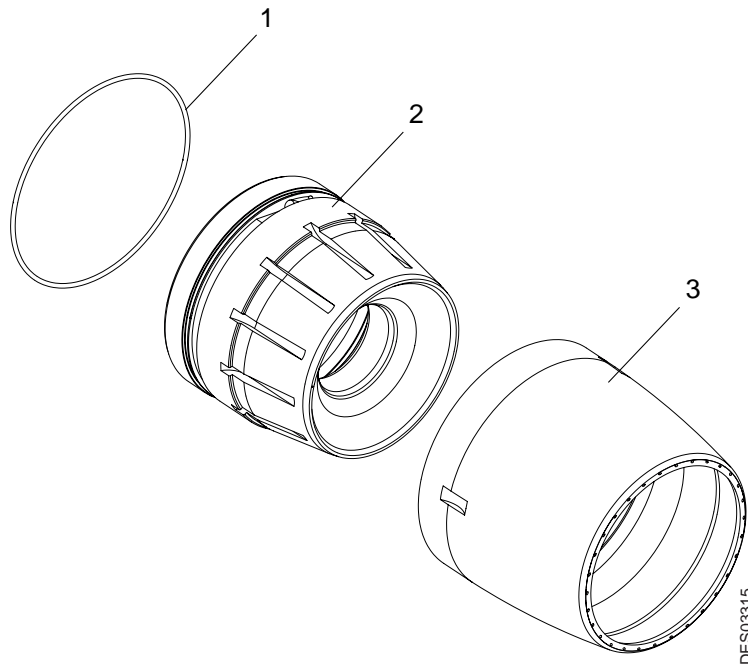

Item	Part number	Description	Qty	Sale unit
	910001300	Vortex shaping air assembly	1	1
1	J2FENV622	O-ring - FEP	1	1
2	900000973	Vortex shaping air shroud - Dia 80 mm	1	1
3	900004555	Vortex outer cover - Dia 80 mm	1	1

6.6. Shaping air assemblies using with external charge atomizers

6.6.1. With EC 65 bellcup for PPH 308 atomizer, external charge

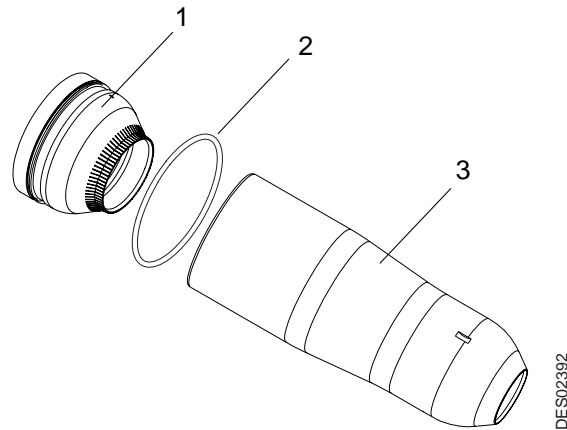

Item	Part number	Description	Qty	Sale unit
	1521092	EC 65 shaping air assembly	1	1
1	1104843	Shaping air shroud	1	1
2	J2FENV622	O-ring	1	1
3	1104907	Outer cover	1	1

6.6.2. With EC 65 bellcup for PPH 607 atomizer, external charge

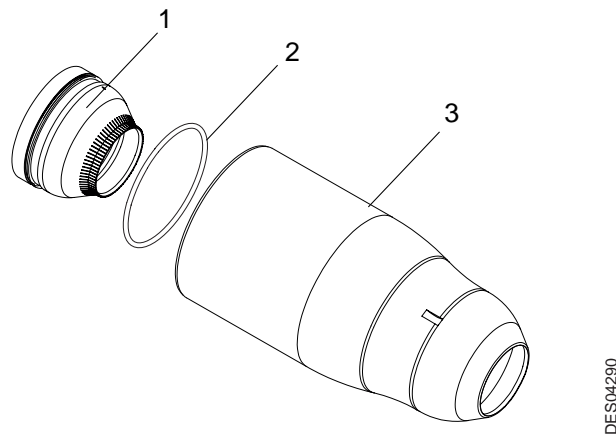

Item	Part number	Description	Qty	Sale unit
	1520425	EC 65 shaping air assembly	1	1
1	1104843	Shaping air shroud	1	1
2	J2FENV622	O-ring	1	1
3	1104844	Outer cover	1	1