



From February 1st, 2017 SAMES Technologies SAS becomes SAMES KREMLIN SAS
A partir du 1/02/17, SAMES Technologies SAS devient SAMES KREMLIN SAS



User manual

Mach-Jet Spray Gun and CRN 457 control module



SAS SAMES Technologies. 13 Chemin de Malacher -
Inovallée - CS 70086 - 38243 Meylan Cedex France
Tel. 33 (0)4 76 41 60 60 - Fax. 33 (0)4 76 41 60 90 - www.sames.com

All communication or reproduction of this document, in any form whatsoever and all use or communication of its contents are forbidden without express written authorisation from SAMES Technologies.

The descriptions and characteristics mentioned in this document are subject to change without prior notice.

© SAMES Technologies 2004



WARNING : SAS Sames Technologies is registered with the Ministry of Labour as a training institution.

Throughout the year, our company offers training courses in the operation and maintenance of your equipment.

A catalogue is available on request. Choose from a wide range of courses to acquire the skills or knowledge that is required to match your production requirements and objectives.

Our training courses can be delivered at your site or in the training centre at our Meylan head office.

Training department:

Tel. 33 (0)4 76 41 60 04

E-mail: formation-client@sames.com

SAS Sames Technologies operating manuals are written in French and translated into English, German, Spanish, Italian and Portuguese.

The French version is deemed the official text and Sames will not be liable for the translations into other languages.

Mach-Jet Spray Gun and CRN 457 control module

1. Regulations, Safety Regulations and Guarantee	5
1.1. Regulations	5
1.2. Safety Regulations	5
1.3. Guarantee	6
2. Presentation	7
3. Characteristics	8
3.1. General characteristics	8
3.2. Compressed air quality	9
4. Operation	10
4.1. Back of "CRN 457" control module	12
4.1.1. Module connections	12
4.1.2. Module identification plate	12
5. Description of spray gun and control module	13
5.1. Functions available from spray gun	13
5.2. Functions available from control module	15
5.3. Summary	16
6. Use of the different control module menus	17
6.1. CRN 457 initialisation screen	17
6.2. Start-up screen	17
6.2.1. Manual unit without PLC connection	17
6.2.2. Manual unit with PLC connection	17
6.3. Cleaning screen (only with a carriage)	18
6.4. Standby screen (only with a communication with a PLC)	18
6.5. Main screen "A"	19
6.6. Screen "B"	21
6.7. Screen "C"	22
6.8. Screen "D"	23
6.8.1. Fault list	24
6.9. Screen "E"	26
6.10. Screen "F"	27
6.11. Screen "G"	28
6.12. Screen "H"	29
7. Maintenance	30
7.1. Deflector and nozzle	30
7.1.1. Disassembly	30
7.1.2. Assembly	30
7.2. Vertical powder pipe	31
7.2.1. Disassembly	31
7.2.2. Assembly	31
7.3. Powder elbow and horizontal pipe	32

7.3.1. Disassembly	32
7.3.2. Assembly	32
7.4. Handle assembly	33
7.4.1. Disassembly	33
7.4.2. Assembly	33
7.5. Trigger	34
7.5.1. Disassembly	34
7.5.2. Assembly	34
7.6. Hand-rest	35
7.6.1. Disassembly	35
7.6.2. Reassembly	35
7.7. Gun	36
7.7.1. Disassembly	36
7.7.2. Assembly	36
7.8. Cable assembly	37
7.8.1. Disassembly	37
7.8.2. Assembly	37
8. Cleaning/Maintenance - - - - -	38
9. Troubleshooting - - - - -	39
10. Spare parts list - - - - -	40
10.1. Mach-Jet Spray Gun	40
10.2. Gun assembly	42
10.3. Handle assembly	43
10.4. Vertical powder pipe assembly	44
10.5. Nozzles	45
10.5.1. Fan spray nozzle	45
10.5.2. Round spray nozzle	46
10.5.3. Extended nozzles, flat spray	47
10.5.4. Extended nozzles, round spray	48
10.6. Equipment	49
11. "FM approved" Configurations - - - - -	50

1. Regulations, Safety Regulations and Guarantee

1.1. Regulations

The "Mach-Jet" spray gun is in conformity with standard EN50050/2001.

Spray gun marking and CRN 457 control module marking:

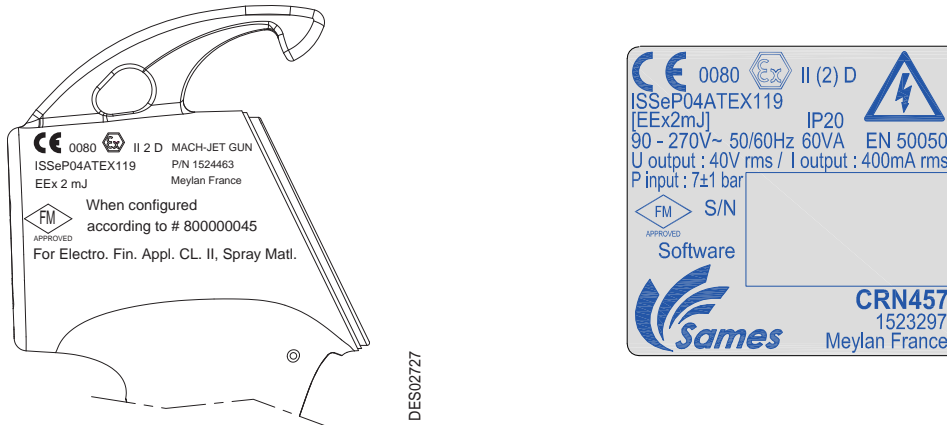

1.2. Safety Regulations

This equipment may be dangerous if it is not used in compliance with the security regulations specified in this manual.

- The CRN 457 electro-pneumatic control module must never be installed where there is a risk of explosion.
- The electrostatic paint spraying equipment must only be used by qualified personnel fully informed of rules no.° 1 to 12 as follows:

- 1 A warning notice written in a language understood by the operator, summarising safety regulations nos.° 2 to ° 9, section 1.1 of this manual, must be placed in a clearly visible position close to the powder-spraying booth.
- 2 Shoes intended for operator use must be anti-static and comply with the ISO 2251 publication. If gloves are used, only anti-static gloves or gloves ensuring grounding of the operator may be worn.
- 3 The floor in the area in which the operator works must be anti-static (ordinary bare concrete floors are anti-static).
- 4 Powder spraying must be carried out in front of a ventilated booth designed for the purpose. Start-up of the CRN 457 must be interlocked with operation of the ventilation system.
- 5 Skin-contact with or inhalation of products used with this equipment may be dangerous for personnel (cf. Safety sheets for products used).
- 6 All conducting structures such as floors, walls of powder-spraying booths, ceilings, barriers, parts to be painted, powder distribution tank, etc. that are inside or near the work station **and the earth terminal on the electro-pneumatic control module** must be electrically connected to the ground system protecting the electrical power supply.
- 7 Parts to be painted must have a resistance in relation to the ground system that is less than or equal to 1 MΩ.

- 8 Powder-spraying equipment must be maintained regularly according to the manufacturer's instructions. Repairs must be carried out in strict compliance with these instructions.
- 9 Before cleaning the spray gun or carrying out any other work in the spraying area, the high-voltage power supply must be switched off in such a way that it can not be switched back on by pressing the spray gun "trigger."
- 10 Only SAMES original spare parts guarantee operating safety of the equipment.
- 11 Ambient using temperature range between 0 and 40° C.
- 12 Switch off the electrical supply of the CRN 457 module before connecting the spray gun.
Before disconnecting the spray gun/ the atomizer, extinguish, switch off the power supply of the CRN 457 (if not, a malfunction can occur).



WARNING : This equipment is intended for spraying powder paint only.

1.3. Guarantee



Guarantee label

During the CRN 457 control module guarantee period, it is strictly forbidden to remove, attempt to remove or cut the label (located under module) on pain of loss of guarantee.

2. Presentation

The “**Mach-Jet**” spray gun is a manual spray gun intended for powder spraying. It is connected to a “**CRN 457**” control module that controls both the high-voltage and the powder flow rate of the spray gun to which it is connected. These two indissociable elements constitute a manual powder-coating device. This new spray gun integrates powder flow rate management and pre-programmed voltage and current settings, which are adjustable from the control module.



3. Characteristics

3.1. General characteristics

Mach-Jet Spray Gun	
Temperature-range for use	0° to 40° C
Maximum output voltage	80 kV (+5kV, - 9kV)
Maximum output current	110 μ A (+ or - 10 μ A)
Supply pressure	7 bar +/- 1 bar
Maximum powder flow rate	24 kg/h
CRN 457 control module	
Power-supply voltage	90 to 270V AC
Frequency	50 - 60 Hz
Maximum power	60 VA
Maximum output voltage	40V effective (rms)
Maximum output current	400 mA effective (rms)
Maximum air flow rate (injection and dilution)	6 m ₀ ³ /h
Maximum air flow rate for auxiliary pneumatic output	12 m ₀ ³ /h

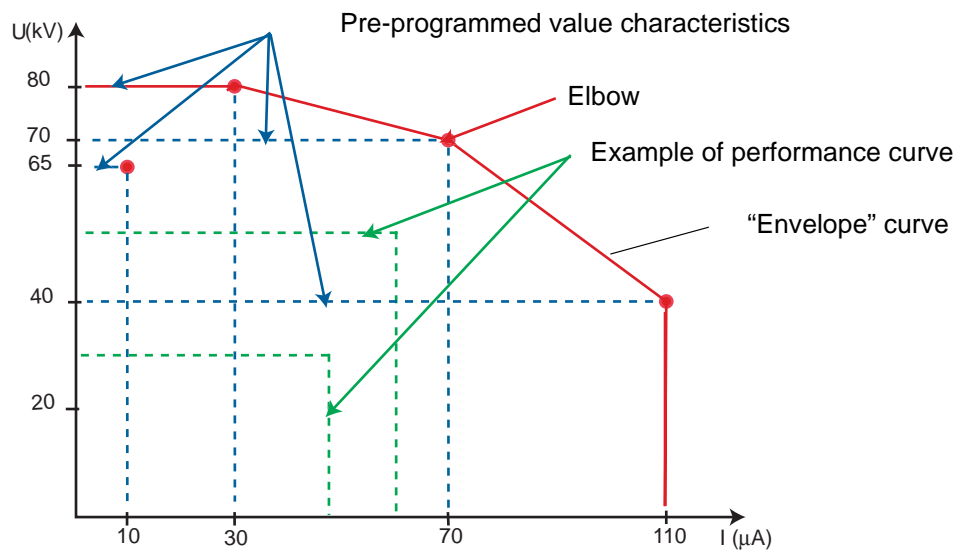

3.2. Compressed air quality

Required characteristics for compressed-air supply according to standard NF ISO 8573-1:

Maximum dew point at 6 bar (90 psi)	Class 4, i.e. +3° C (38°F)
Maximum particle-size of solid pollutants	Class 3, i.e. 5 µm
Maximum oil concentration	Class 1, i.e. 0.01 mg/m ³ *
Maximum concentration of solid pollutants	Class 3, i.e. 5 mg/m ³ *

*: Values are given for a temperature of 20° C (68° F) at an atmospheric pressure of 1,013 mbar.



WARNING : Non-compliance with these characteristics may result in incorrect operation of the “CRN 457” control module.



WARNING : A 5µfilter must be installed upstream of the “CRN 457” control module compressed-air supply system. The size of this filter depends on the size of the installation. Sames Technologies advises to use a filter like the one indicated in section ([see § 10.6 page 49](#)). If any damage on the equipment happens because of a polluted air, the warranty could be not applied.

4. Operation

The **Mach-Jet** spray gun is connected to the **CRN 457** control module via a serial link embedded in the electrical connection cable. This link enables recognition of the spray gun and the exchange of data necessary for operation.

Methods for modifying or adjusting settings are described in the following chapters. It is possible to return to the original “factory” settings at any time ([see § 6.1 page 17](#)).

In the case of a manual unit not connected to an industrial PLC:

The first time the control module is started up, the operator selects the operating mode for powder feed; three possibilities are proposed:

- Use of a vibrating table (factory parameter).
- Use of a round fluidisation tank.
- Use of a cup.

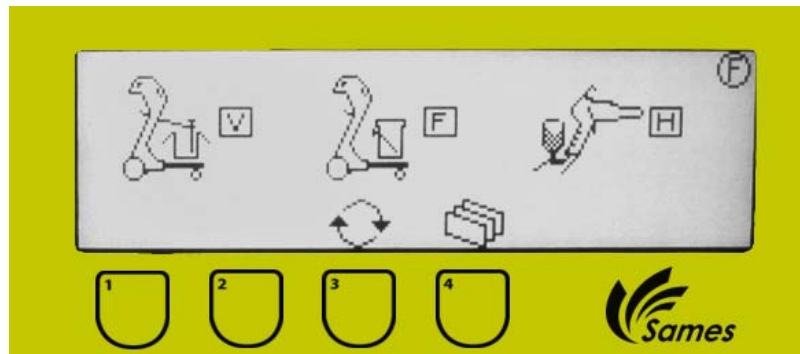

WARNING : This use parameter can then be modified at any time in the “F” menu displayed on the control module.

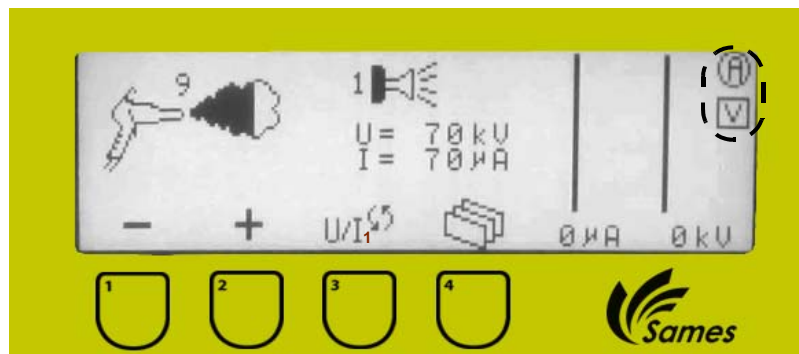

In the case of a manual unit connected to an industrial PLC:

In this case, the spray gun is connected to the PLC via the “PLC plug.” The following parameters must be entered on start-up.

Parameters	Factory value	Minimum	Maximum
Remote mode - Slave index	1	1	99
Remote mode - Communication speed	9,600 baud	1,200 baud	38,400 baud
Auxiliary EV action synchronised with the trigger	0	0	1

The communication speed is selected from the following list: 1,200, 2,400, 4,800, 9,600, 14,400, 18,200 and 38,400 baud.



Front of CRN 457 module manual unit with PLC connection

4.1. Back of “CRN 457” control module

4.1.1. Module connections

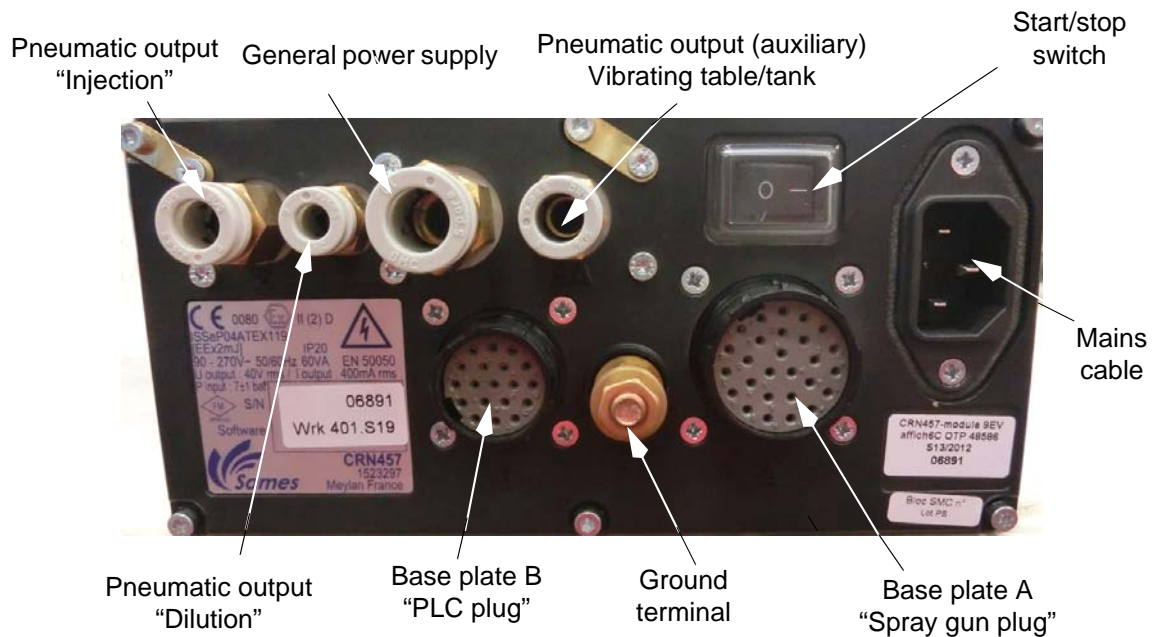

4.1.2. Module identification plate

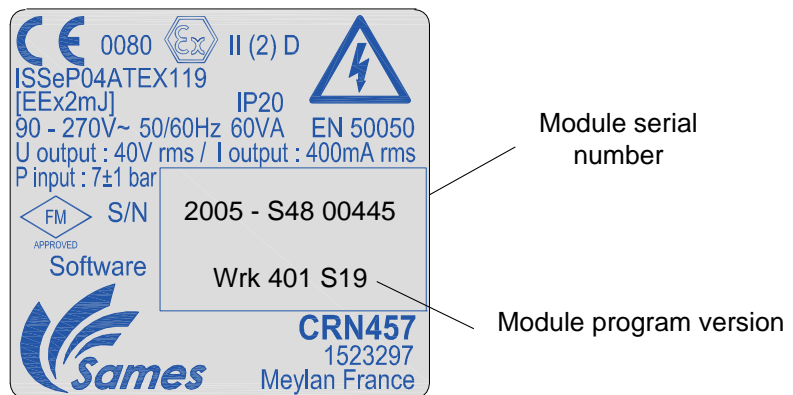

5. Description of spray gun and control module

The function of the manual spray gun is to spray powder electrically charged by a high-voltage unit built into the spray gun that delivers up to 80 kV and 110 μ A.

Only pressure on the trigger enables start-up of the power supply and electrical charging of the powder.

5.1. Functions available from spray gun

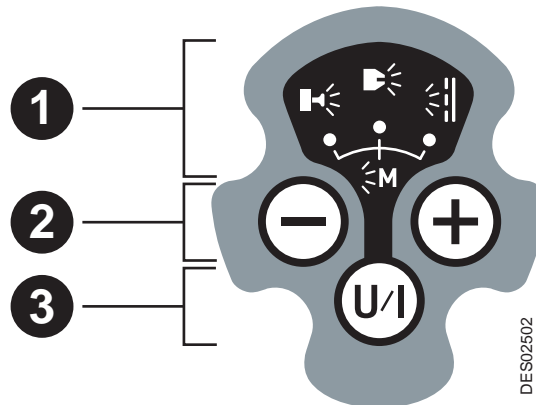

Area 1: The red LED under each icon corresponds to the selected voltage/current characteristic in progress. Selection of a different characteristic is only possible if the trigger is released.

		Factory settings
Round spray nozzle mode application icon		U = 70kV and I = 70 μ A
Fan spray nozzle mode application icon		U = 80kV and I = 30 μ A
“Over-powder-coating” mode application icon		U = 65kV and I = 10 μ A
Metallic powder mode application icon. (The three LEDs are lit for this choice).		U = 40kV and I = 110 μ A

Simultaneous flashing of all LEDs indicates a communication fault with the control module ([see § 6.8.1 page 24](#)).

Area 2: Powder flow rate can be adjusted here.

- It can be reduced by pressing the button
- or increased by pressing the button

There are thirteen powder flow rate setting levels, one of which is zero. The operator can display the powder flow rate on the “CRN 457” control module. A powder cloud fills up with an index varying from 0 to 12 (there is no corresponding display on the spray gun). On start-up of the spray gun, the powder flow rate value is 0 (zero flow rate). It is possible to select the flow rate without having to press the trigger.

Area 3: This area is used for selecting pre-programmed voltage/current characteristics. On start-up, a red LED lights up below the "round spray nozzle" icon and pressing the "U/I" button enables selection of one of the four characteristics.



WARNING : For guns sold since 2006, it is possible to display the " cleaning screen " by pressing onto U/I key for 2 seconds. The output of this screen is similar to the input one.

If E screen mentions : "Mach-Jet V > or = 1" this function is available; if E screen mentions "Mach-Jet V = 0", the gun is not equipped with this function.

5.2. Functions available from control module

The control module displays use parameters and their settings, which can be changed using the four buttons on the front panel.

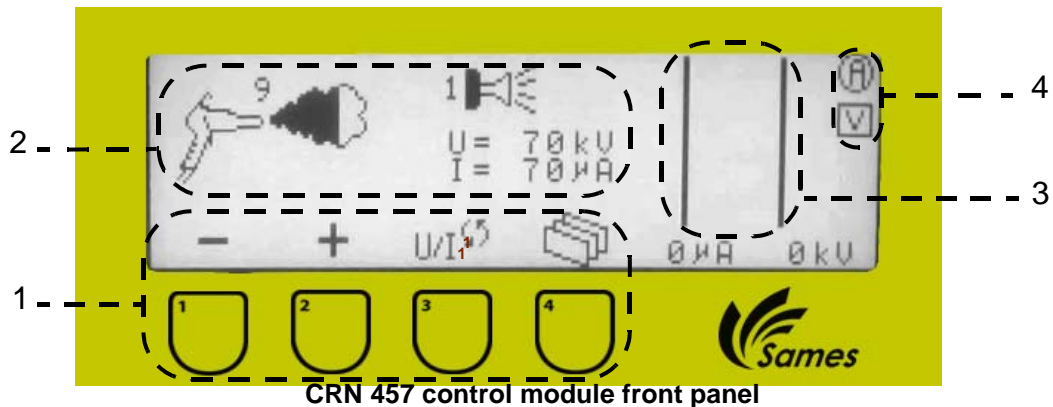

The operator has access to menus from A to H and to a cleaning screen.

- **A:** Powder flow rate adjustment and selection of pre-set characteristics (U/I).
- **B:** Dilution air adjustment and selection of pre-set characteristics (U/I).
- **C:** Manual adjustment (voltage/current).
- **D:** History of faults encountered (accessible only if a fault is recorded).
- **E:** Screen adjustment (contrast, etc.) and indication of Mach Jet version.
- **F:** Unit configuration; either vibrating table either fluidisation tank (only in the case of using a carriage) or cup.
- **G:** Configuration with computer link (only in the case of a manual unit connected to an industrial PLC).
- **H:** Choice for the type of the characteristics U/I 1 or U/I 2.
- Cleaning screen / Standby screen.

Area 1: The front panel of the module has four buttons.

A graphic icon located above each button indicates the button's purpose.

Area 2: This display area indicates parameter status.

For example: For screen **A**, the powder flow rate is set at 9. The cloud at the spray gun outlet is partially filled (9/12) and the pre-programmed characteristic is that of the round spray nozzle.

Area 3: The bar graph located in this area shows the instant voltage and current values in graphic and digital form.

Area 4: A screen entitled "Main" appears on start-up. It is identified by an icon located at the top right-hand side of the screen. .

Without PLC: The graphic icon **[V]** appears under the menu index. This description corresponds to the type of powder supply; two are possible:

- **[V]:** Use of vibrating table (parameter indicated by default, factory setting).
- **[F]:** Use of fluidisation tank.
- **[H]:** Use of cup.

(This choice can be made at any time by going to the "F" menu).



If this logo appears under **[V]**, it indicates that the generator has shut down because of a fault (see § 6.8.1 page 24).



When the trigger is pressed, this logo flashes (the arrow indicates presence of high voltage at the bottom of area 4).

5.3. Summary

- Selection of U and I pre-programmed characteristics (from spray gun or control module) is only possible if the operator is not painting.
- Powder flow rate is adjustable (high voltage activated or not):
 - From the control module.
 - From the spray gun.
- It is possible to powder-coat regardless of the menu in progress with the exception of the "Cleaning" menu.
- The operator may return to the factory parameters at any time ([see § 6.1 page 17](#)).
- The operator may switch to a cleaning screen by pressing button 4 (regardless of the screen displayed) for more than two seconds.

6. Use of the different control module menus

6.1. CRN 457 initialisation screen

This is the first screen displayed on start-up of CRN 457.



Pressing buttons 1 and 2 simultaneously (until appearance of the logo at the middle right-hand side) enables the device to restart with factory parameters. The operator is thus in a first start-up situation.

6.2. Start-up screen

6.2.1. Manual unit without PLC connection

This screen enables selection of “vibrating table” or “fluidisation tank” or “cup”.

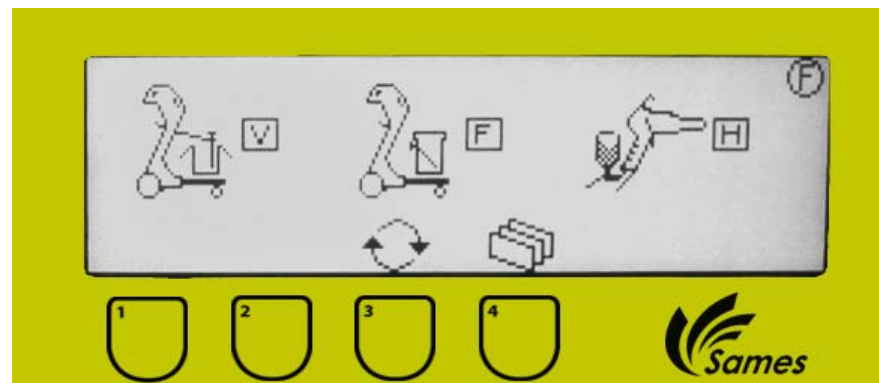

When the “vibrating table” is used, the “auxiliary” pneumatic outlet is activated while the trigger is pressed. When the fluidisation tank is used, activation occurs 30 minutes after the last pressure on the trigger.

6.2.2. Manual unit with PLC connection



6.3. Cleaning screen (only with a carriage)



[1]: This button starts up or stops the cleaning mode.

Pressing the 0/1 button puts the system in cleaning mode; a computer animation appears on the screen (flashing).

Cleaning mode must be stopped before proceeding with the next operation.

The spray gun commands are disabled.

[2]: This button enables switching to the following menu

Pressing the button is forbidden when the installation is in cleaning mode.



6.4. Standby screen (only with a communication with a PLC)



[1]: Pressing this button quits "Standby mode".

Pressing this button quits "Standby" mode and triggers an automatic return to screen A.

Spray gun commands are disabled in this screen.

6.5. Main screen “A”

This screen enables selection of work parameters and display of spray gun operation. From the keyboard, the operator can select the powder flow rate and a pre-set characteristic (U/I).

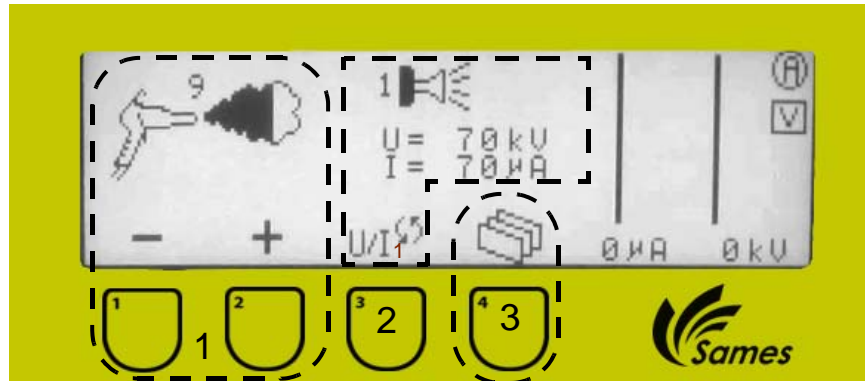

[1]: Powder flow rate can be adjusted in this area.

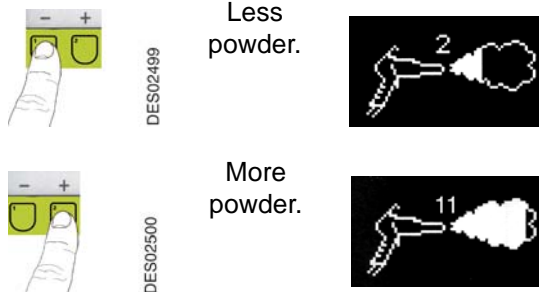

There are 13 different flow rates (from 0 to 12) (0 corresponds to a zero flow rate).

[3]: This button enables switching to the following menu or positioning on the cleaning screen by pressing the button for more than two seconds.



Pressing the button validates the parameters, the U/I characteristic remains unchanged and the operator has access to the next menu, “B.”

[2]: This button enables selection of a pre-set characteristic (U/I).

Pressing this button gives a looped display of the following logos.



- | | |
|--|------------------------------------|
| | Use of a round spray nozzle. |
| | Use of a fan spray nozzle. |
| | “Over-powder-coating” application. |
| | Metallic powder application. |

The selected flow and U/I characteristic are memorized after:

- 1 seconds without modification of flow parameters or U/I characteristics.
- Change of screen.
- Trigger pressed.

Recommended settings

Use of a round spray nozzle

Application using a round spray nozzle improves charging of particles. It gives a better wraparound effect and has better transfer efficiency. The spray is very homogenous both on complex and simple parts.

Use of fan spray nozzles

Application using a fan spray nozzle gives better covering and very high performance on flat parts. Powder-covering of cavities is facilitated. The spray is very penetrating and homogenous both on complex and simple parts.

Use of a current in excess of 30 μA may result in reduced transfer efficiency and electrode soiling.

Application in “over-powder-covering” mode adapted with round or fan spray nozzles

This application may require an adjustment of settings in the case of a very thick first coat of powder with appearance of “eyes” and large craters. The current may be progressively reduced (see voltage/current adjustments) until correct application is obtained (5 μA minimum). It is used for applying thick coats (> 100 μm) and for parts with low conductivity (glass, wood, etc.).

Metallic powder application adapted with round or fan spray nozzle

This application can be optimised if the powder is “coated,” the voltage can be increased to improve application performance.

To optimize the aspect of the part (tight, crater), the operator may have to increase the voltage up to 50kV and to decrease the current down to 5 μA .

6.6. Screen “B”

It is used for dilution air adjustment and selection of pre-set characteristics (U/I).

Dilution air is used to avoid spray pulses. This adjustment also acts on powder spray speed.

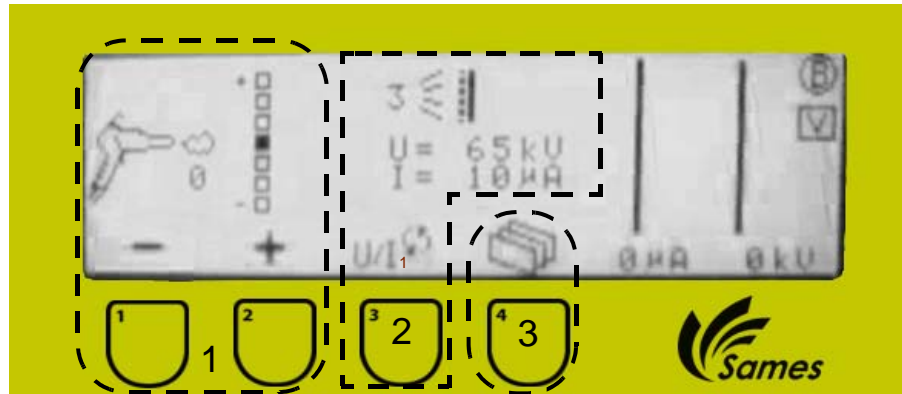

[1]: Dilution air can be adjusted in this area.



DES02499
Less air:
- Slower spray
- Risk of pulses.

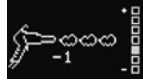

DES02500
More air:
- Faster spray
Fewer pulses

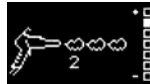

There are 7 different settings (from -3 to +3)

[3]: This button enables switching to the following menu or positioning on the cleaning screen by pressing the button for more than two seconds.

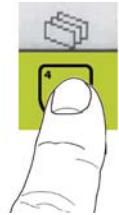

Pressing the button validates the parameters, the U/I characteristic remains unchanged and the operator has access to the next menu, “C.”
It is possible to powder-coat and see the influence of adjustments before validating. If no action is taken, the display switches automatically to screen “A” after one minute.

[2]: This button enables selection of the pre-set characteristic (U/I).

Pressing this button gives a looped display of the following logos.

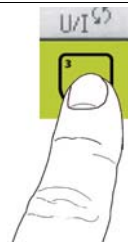

ES02512

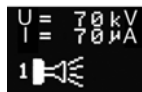

Use of round spray nozzles.



Use of fan spray nozzles.

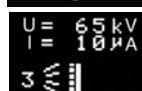

“Over-powder-coating” application.

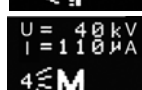

Metallic powder application.

6.7. Screen “C”

It is used to modify the voltage and current settings of the characteristic selected in menus A and B.

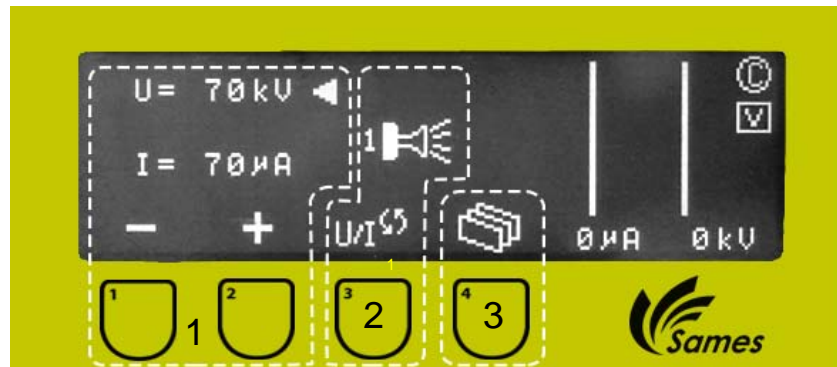

[1]: Voltage or current can be modified in this area.



The voltage or current value decreases when the flashing cursor is opposite the parameter to be modified.



The voltage or current value increases when the cursor is opposite the parameter to be modified.

When values are modified, the hand logo appears (see [2]).
The hand logo disappears on return to factory parameters.



[3]: This button enables switching to the following menu or positioning on the cleaning screen by pressing the button for more than two seconds.



DES02511

Pressing the button validates the parameters and the operator has access to the next menu, “D”.
If no action is taken, the display switches automatically to screen “A” after one minute.

[2]: This button pinpoints the parameter (U or I) to be modified.

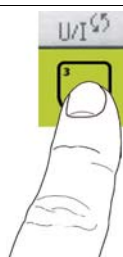

ES02512



If U is to be increased, I decreases automatically if positioned on the envelope curve of the characteristic ([see § 3.1 page 8](#)) and vice-versa.

6.8. Screen “D”

This screen is used to display the history of faults encountered.

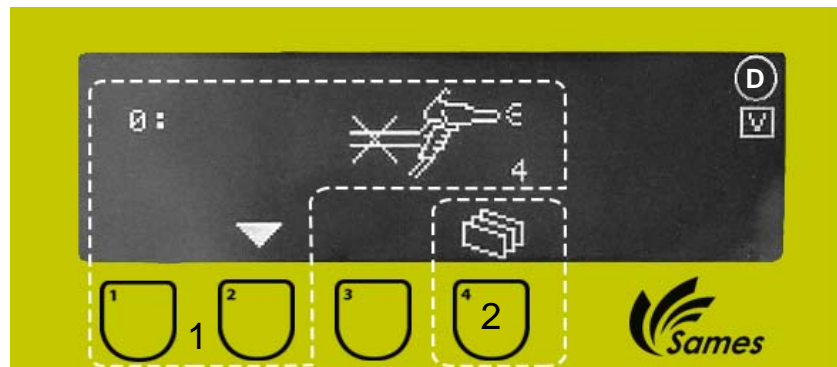

DES02496

[1]: The history of the most recent faults can be displayed in this area. The last fault with its index (4, in this case) appears on the screen. The fault's age index is indicated on the left-hand side of the screen: 0.



Display of faults from oldest to most recent.



Display of faults from most recent to oldest.

[2]: This button enables switching to the following menu or positioning on the cleaning screen by pressing the button for more than two seconds.



If no action is taken, the display switches automatically to screen “A” after one minute. Immediate return to screen “A” if the trigger is pressed.

If no faults are detected, the operator can not access screen “D”.

The last 96 faults are recorded; the 97th alters the list and deletes the 96th, which is the preceding fault.

When a fault occurs, the high-voltage and powder supplies are disabled. A specific screen enables identification of the fault and its number.

The operator confirms its recognition by validating with button “4”.

6.8.1. Fault list

Fault number	Icon	Comment
1		"CRN 457" general fault
2		No "Mach-Jet" connection
3		"CRN 457" temperature excessive
4		High-voltage action forbidden
5		"CRN 457" general fault
6		"CRN 457" general fault
7		"CRN 457" general fault
8		"CRN 457" general fault
9		Short-circuit
10 to 18		Solenoid valve index Vi (V1 to V8), Vx: Auxiliary solenoid valve
19		"CRN 457" configuration fault

Faults 1, 5, 6, 7 and 8 are the result of electrical power problems. Switch the control module off then back on, if the problem persists, contact Sames Technologies.

Fault 2 is a communication problem caused by a damaged or disconnected cable; no link with the "Mach-Jet" spray gun.

Fault 3 is caused by excessive temperature inside the control module. In case of the control module should reach a too high temperature, risking damaging it, the high voltage is switched off and a warning message is displayed on the control module.

Work can be continued by pressing once on to the trigger to acknowledge the fault, but this latter will come back every minute as long as the temperature has decreased to an acceptable level. An alarm will remain displayed on the screen as long as the temperature is too high.

The operator will have to make the temperature decrease (Make sure as well that the temperature of the compressed air is lower to 40°C).

Le **Fault 4** appears when the trigger is engaged on start-up of the spray gun. The spray gun is rearmed by releasing the trigger and pressing it again.

Fault 9 appears when there is a short-circuit on the gun. The spray gun is rearmed by activating the ON/OFF button of the CRN 457. Systematically, check the wiring of the gun.

Faults 10 to 18 are detected when electrical power-supply faults occur on the different solenoid valves; if a fault of this nature occurs: contact Sames Technologies.

Fault 19 appears when the CRN 457 changed configuration since its powering:

- The strap of the automatic mode is detected while the CRN 457 started in manual mode .
- The strap of the automatic mode is not any more detected while the CRN 457 started in automatic mode.

6.9. Screen “E”

This is used to adjust the screen.



[1]: Screen contrast can be modified in this area. Pressing the buttons corresponds to:



Reducing contrast, the screen becomes increasingly brighter.



Increasing contrast; the screen becomes increasingly darker.

[3]: This button enables switching to the following menu or positioning on the cleaning screen by pressing the button for more than two seconds.



Pressing the button validates the parameters and the operator has access to the next menu, “F” or “G” with a PLC.

If no action is taken, the display switches automatically to screen “A” after one minute. Immediate return to screen “A” if the trigger is pressed.

[2]: This button reverses the screen colour.



Pressing this button reverses the display in a loop:

- Either the graphics are write on a black background.
- Or the graphics are black on an white background.



or



6.10. Screen "F"

This screen is used to select the powder supply (vibrating table, fluidisation tank or cup), therefore only in the case of a manual unit with no connection to a PLC.

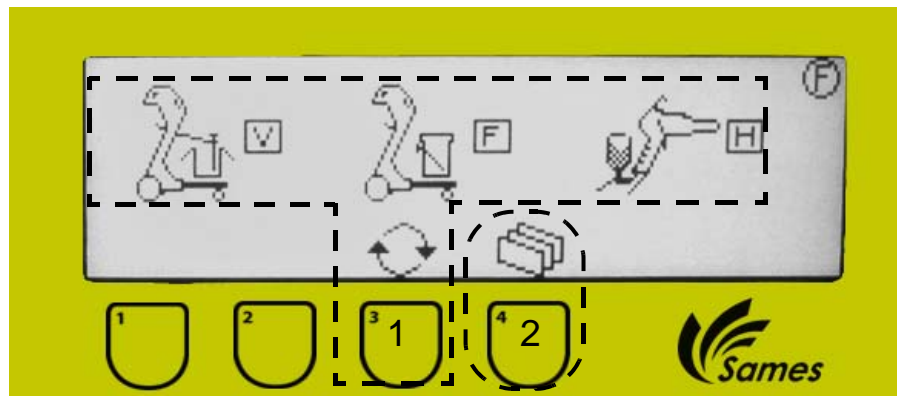

[1]: This button enables selection of the powder-supply mode.

Pressing this button moves the flashing cursor in front of the operating mode.

[2]: This button enables switching to the following menu or positioning on the cleaning screen by pressing the button for more than two seconds.



Pressing the button validates the parameters and the operator has access to the next menu, "A".

If no action is taken, the display switches automatically to screen "A" after one minute.
Immediate return to screen "A" if the trigger is pressed.

6.11. Screen "G"

This screen is used to consult the adjustment parameters for remote mode, only in the case of a manual unit connected to a PLC.



[1]: This button enables switching to the following menu or positioning on the cleaning screen by pressing the button for more than two seconds.



The operator has access to the next menu, "A".

Immediate return to screen "A" if the trigger is pressed.

6.12. Screen "H"

It is used to select the type of characteristics U/I_1 or U/I_2 .

U/I_1 type is the most common one.

The electrostatic power is the highest one. It allows painting a part even at a far distance.

U/I_2 type allows reducing the electrostatic power when the operator moves away from the part. This type of characteristics avoids the hand of the operator to be covered with paint.



WARNING : With U/I_2 , the part has to be painted at a maximum distance of 300 mm otherwise, the electrostatic effect is weakened.

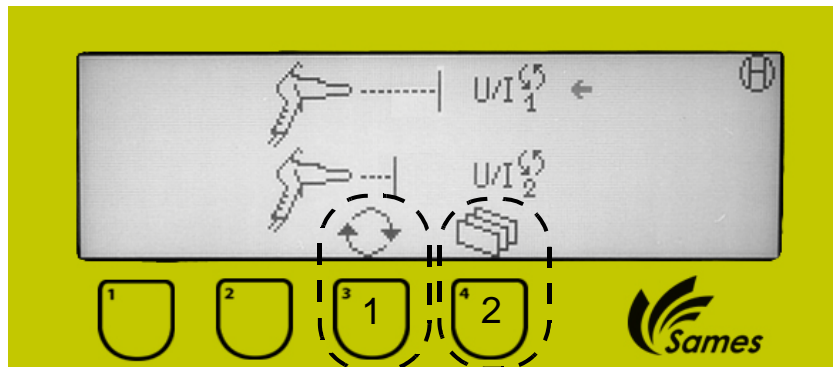

[1]: This button allows selecting U/I_1 or U/I_2 characteristics.

Pressing this button moves a flashing pointer in front of the using mode.

[2]: This button enables switching to the following menu or positioning on the cleaning screen by pressing the button for more than two seconds.

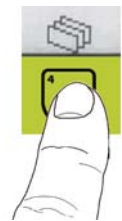

the operator has access to the next menu, "A".

Immediate return to screen "A" if the trigger is pressed.

7. Maintenance



WARNING : Switch off the electrical supply of the CRN 457 module before connecting the spray gun. Before disconnecting the spray gun/ the atomizer, extinguish, switch off the power supply of the CRN 457 (if not, a malfunction can occur).

7.1. Deflector and nozzle

7.1.1. Disassembly

Deflector

- To disassemble the deflector, simply pull it. It is not necessary to remove the nozzle nut.

Nozzle

- Remove the deflector.
- Unscrew the nozzle nut manually.
- Remove the nozzle.

7.1.2. Assembly

- Proceed in reverse order having first checked and cleaned the different components. Replace them if necessary.

- Clean the electrical connection located in the barrel.

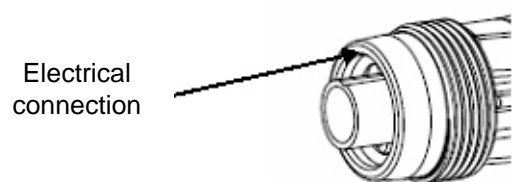

- Turn and push the tip (item 4) inside the barrel (item 5).

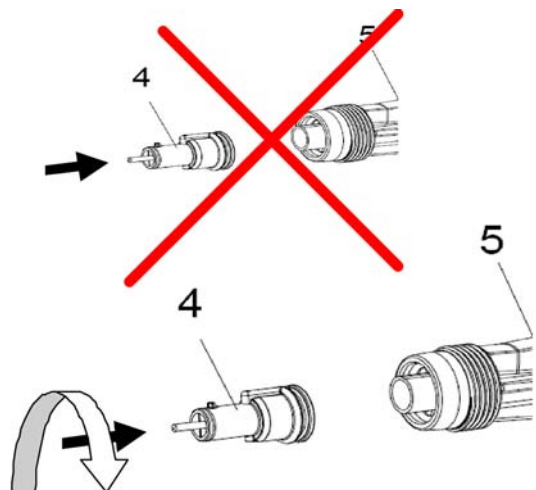

7.2. Vertical powder pipe

7.2.1. Disassembly

- Remove the powder union.
- Start unscrewing the powder pipe using a 17-mm ring wrench and then continue manually.



WARNING : This wrench is required, otherwise there is a risk of damaging the material of the powder pipe.

- Remove the powder pipe from the handle assembly.

7.2.2. Assembly

- Clean the interior of the powder pipe with compressed air.
- Check the state of the seals and the powder pipe. Replace them if necessary.
- Install the pipe in the handle assembly, it locates automatically in the powder elbow, then push it in until it stops.
- Tighten manually then continue tightening using the 17-mm ring wrench.
- Connect the powder union to the vertical pipe.

7.3. Powder elbow and horizontal pipe

The powder elbow guarantees the connection between the horizontal powder pipe located in the gun and the vertical powder pipe located in the handle assembly.

7.3.1. Disassembly

With the powder pipe already removed ([see § 7.2.1 page 31](#)).

- Remove the four screws and washers located on the back of the spray gun (items 1 and 2) using a Philips PH 1-tip screwdriver.
- Gently withdraw the gun assembly (item 5) from the handle assembly (item 6). Be careful not to pull out the three contact screws (high-voltage unit connection (item 3)).
- Remove the powder elbow (item 4) by pulling it towards the handle assembly.
- Horizontal powder pipe removal (Operation necessary only when replacing the powder pipe), insert the new pipe into the gun (nozzle nut side) and push out the old one.

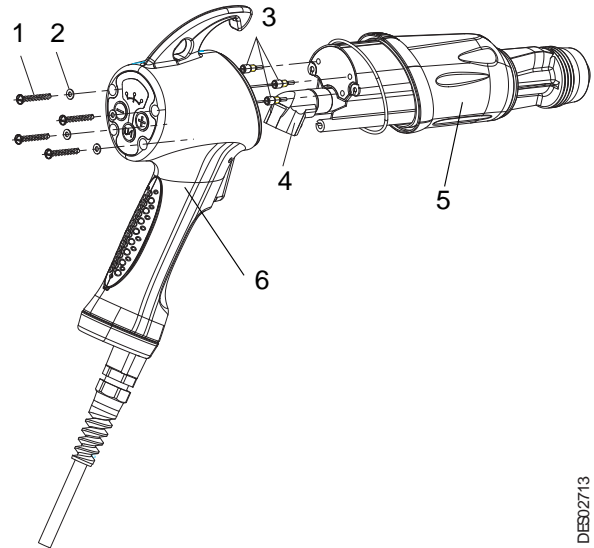

7.3.2. Assembly

- Clean the interior of the powder pipe located in the gun with compressed air.
- Check the state of the elbow and its seal. Clean with compressed air and replace if necessary.
- Insert the elbow with its seal into the horizontal powder pipe; the elbow seal must no longer be visible from the outside.
- Fit the four screws and washers.



WARNING : When unscrewing the screws, it is possible that the washers may remain in place. To extract them, use a maxi 3mm screwdriver and remove them by pushing from the interior of the handle.

Change these washers each time the screws are removed.

- Use a torque screwdriver to tighten these screws to a torque of 0.75 Nm.

7.4. Handle assembly

7.4.1. Disassembly

- Follow vertical powder pipe disassembly procedure ([see § 7.2.1 page 31](#)).
- Unscrew the four screws (item 1) located on the back of the spray gun using a Philips PH 1-tip screwdriver and remove the washers (item 2).
- Gently withdraw the gun assembly (item 4) from the handle assembly (item 5). Be careful not to pull out the three high-voltage unit connection wires.
- Unscrew the three screws (item 3) manually to disconnect the high-voltage unit.

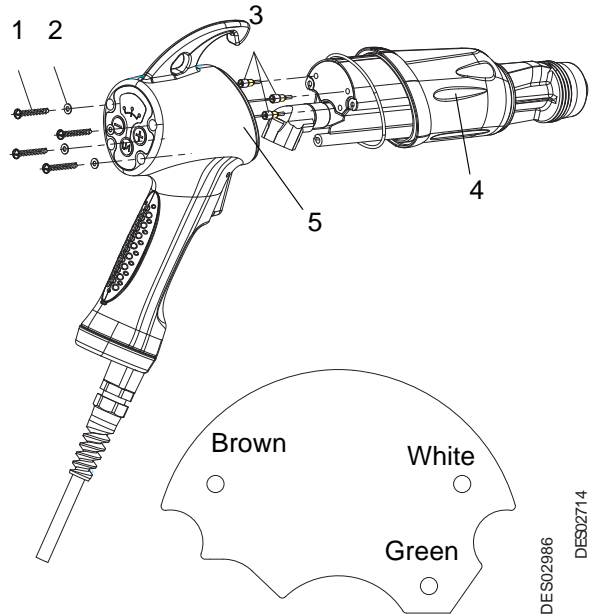

7.4.2. Assembly

- Connect the 3 power-supply wires, complying with the wiring diagram (see illustration). Check alignment of the three contacts. Fully tighten manually without forcing.
- Fit the handle assembly to the gun. Check the position of the wires to avoid possible pinching by the handle assembly. Push until stop is reached.
- Refit the four screws and washers (items 1 and 2).



WARNING : When unscrewing the screws, it is possible that the washers may remain in place. Loosen them using a 3-mm (max.) screwdriver and remove them. Change these washers each time the screws are removed.

- Tighten these screws to a torque of 0.75 Nm.

7.5. Trigger

7.5.1. Disassembly

- Using a dia. 1.5 mm drift punch, remove the pin fixing the trigger to the handle assembly (see figure 1).
Be careful not to lose the spring.

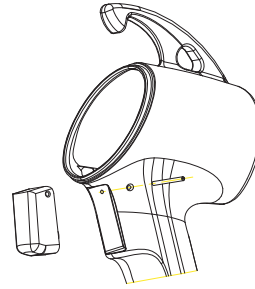

Figure 1

7.5.2. Assembly

- Replace the spring around the magnet (as shown in figure 2).
- Place the trigger in its housing, port upwards (as shown in figure 3).
- Replace the pin. It must be correctly centred and must not protrude from either side.

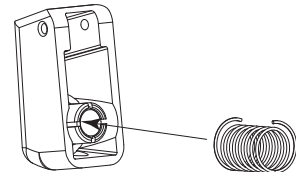

Figure 2

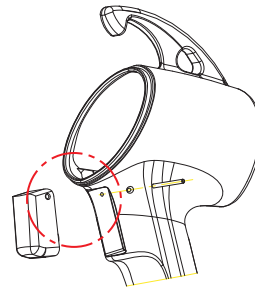

Figure 3

DES02712

7.6. Hand-rest

7.6.1. Disassembly

- Place a flat screwdriver in the notch on the hand-rest located on the handle assembly.
- Lever upwards slightly and remove the hand-rest from its location.

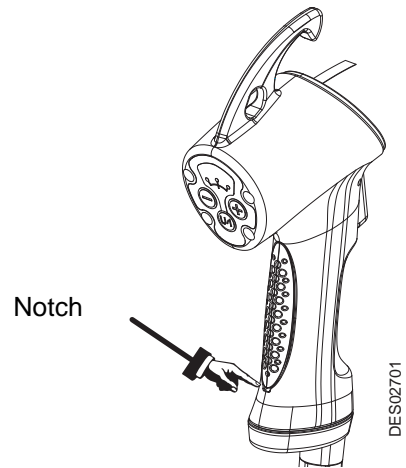

7.6.2. Reassembly

- Place the hand-rest on the positioning pin and apply light pressure on the clipper (a click must be heard).

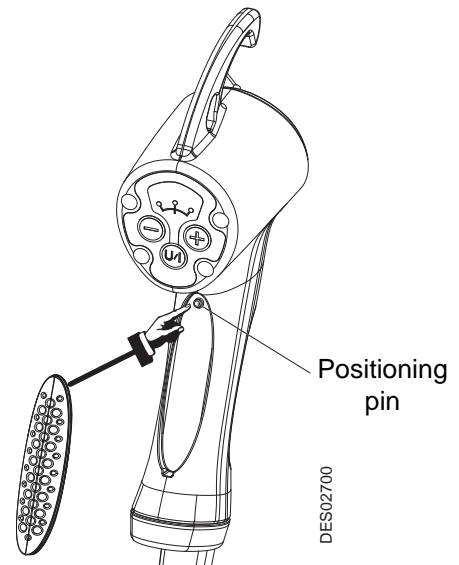

7.7. Gun

7.7.1. Disassembly

- Follow handle assembly disassembly procedure ([see § 7.4.1 page 33](#)).
- Remove the powder elbow and the powder pipe from the gun ([see § 7.3.1 page 32](#)).

7.7.2. Assembly

- Clean the gun, replace it if necessary. Change the gun seal making sure to position it correctly in the gun groove.
- Proceed in reverse order for reassembly, [see § 7.3.2 page 32](#) then [see § 7.4.2 page 33](#).



WARNING : To guarantee correct sealing each time the gun is disassembled, always replace the O-ring.

7.8. Cable assembly



WARNING : This operation is delicate and must be carried out with extreme care.

7.8.1. Disassembly

- **Stage 1:** Remove the powder pipe ([see § 7.2.1 page 31](#)).
- **Stage 2:** Unscrew the 4 screws fixing the handle assembly to the gun.
- **Stage 3:** Unscrew the 3 electrical connection wires on the gun and remove it ([see § 7.4.1 page 33](#)),
- **Stage 4:** Unscrew the strain relief (item 2) Unscrew the stuffing box (item 1) using a 19-mm flat wrench, unscrew the 3 screws (item 3) from the base plate (item 4) to separate it from the handle assembly and lower the base plate to unscrew the green/yellow wire fixing screw (item 5).
- **Stage 5:** Remove the box (Hall effect sensor - Item 8, figure 2) from its housing located behind the trigger in the upper part of the handle assembly using a flat screwdriver.
- **Stage 6:** Unscrew the end-of-handle-assembly board (item 6, figure 2) and remove it from the handle assembly.
- **Stage 7:** Unplug the black connector (item 9, figure 2).
- **Stage 8:** Unscrew the strain relief (item 7, figure 2) located on the shield of the electronic board.
- **Stage 9:** Remove the cable from the handle assembly.

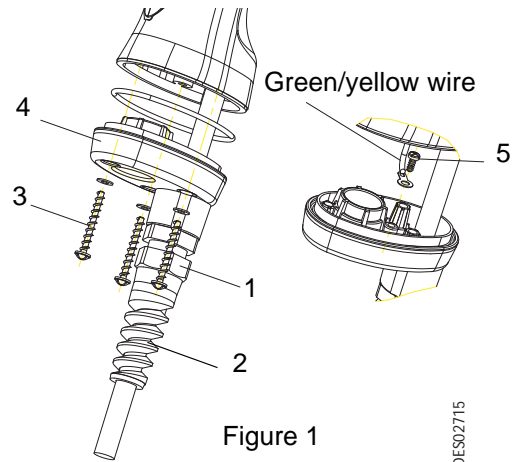

Figure 1

DES02715

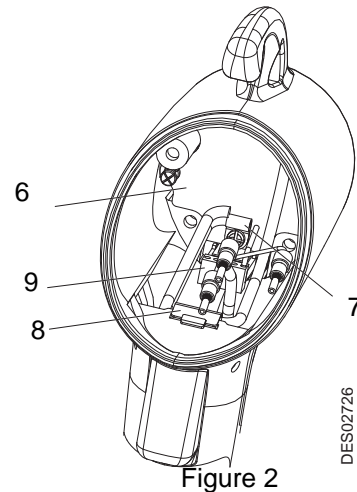

Figure 2

DES02726

7.8.2. Assembly

- **Stage 1:** Take a new cable equipped with its base plate.
- **Stage 2:** Insert the cable into the handle assembly, ensuring that it is correctly positioned (see figure 2). **Be careful not to pass the cable through the powder pipe housing.**
- **Stage 3:** Fix the strain relief (item 6, figure 2) (recovered) to the shield of the board, ensuring that it is correctly positioned.
- **Stage 4:** Connect the connector to the board.
- **Stage 5:** Fix the board (item 5, figure 2) in the bottom of the handle assembly using the two screws.
- **Stage 6:** Replace the sensor box (item 7, figure 2) in its housing.
- **Stage 7:** Fix the green/yellow wire (item 4, figure 1) to the handle assembly base plate.
- **Stage 8:** Reassemble the base plate (item 3, figure 1); retighten the stuffing box to a torque of 3.5 N.m, it is necessary to loosen the strain relief on the stuffing box before proceeding with this operation. Tighten the strain relief on the stuffing box.
- **Stage 9:** Change the gun seal.
- **Stage 10:** Reconnect the gun power-supply wires ([see § 7.4.2 page 33](#)).
- **Stage 11:** Reposition the gun and handle assembly making sure not to pinch the gun power-supply wires.
- **Stage 12:** Install the vertical powder pipe ([see § 7.2.2 page 31](#)).

8. Cleaning/Maintenance



WARNING : All cleaning operations must be done only with depressurized compressed air with a 2,5 bar maximum pressure, a cloth or a brush, if necessary. Never use water or solvents to clean equipment, with the exception of the deflector.

Fouling and wear of the Mach Jet spray gun caused by the passage of powder vary according to operating conditions and the type of powder used.

For this reason, the maintenance frequency indicated here is given as a guide only. With a little experience of using SAMES equipment, the user will be able to draw up his own maintenance schedule. Nevertheless, as an initial guide, the following maintenance programme is recommended:

Frequency	Action
Before starting work	Check the safety regulations. see § 1 page 5.
Every 8 hours	Switch off the "CRN 457" mains power supply, disassemble and clean the nozzle and compressed air electrode. Make sure that there is no accumulation of powder on the electrode. Clean the powder ducts by blowing compressed air through the powder end-piece below the handle assembly without disassembling it.
Between 40 and 60 hours of work	Clean the round spray deflector by leaving it to soak for a few hours in methyl-isobutyl-ketone (MIBK)*.
From 3 to 6 months	Check the state of wear and soiling of the powder elbow, replace it if necessary.



WARNING : * MIBK solvent is toxic and flammable.

9. Troubleshooting

Symptoms	Probable causes	Remedies
Drop in powder flow rate	Elbow soiling	Disassemble the spray gun, clean it or replace the elbow.
	Clogging of powder-supply hose	Unclog the powder hose using compressed air.
	Wear and fouling of powder pump.	Refer to powder pump user manual.
Powder does not adhere to the part	No high voltage: - Incorrect connection of daisy chain following assembly/disassembly. - Low-voltage cable cut off	Check the three high-voltage unit connections. Replace the low-voltage cable.
	Incorrect U/I adjustment	Use "factory" settings.
	Incorrect pneumatic adjustment	Use "factory" settings.

Item	P/N	Description	Qty	Unit of sale	Maintenance level for spare parts (*)
	1524463	Mach-Jet Spray Gun	1	1	3
	1524463-12	Mach-Jet spray gun assembly (with 12-m cable)	1	1	3
	1524463-18	Mach-Jet spray gun assembly (with 18-m cable)	1	1	3
1	1524464	Gun assembly (see § 10.2 page 42)	1	1	3
2	1525492	Fan spray nozzle assembly (see § 10.5.1 page 45)	1	1	1
3	1313519	Medium fan spray deflector (see § 10.5.1 page 45)	1	1	1
4	1311739	Nozzle nut	1	1	3
5	1525493	Round spray nozzle assembly (see § 10.5.2 page 46)	1	1	1
6	1411993	Round spray deflector, Dia.: 25 mm	1	1	1
7	X3GJCP004	Screw PT KA25x6 WN1412 galvanised steel, cross-head	2	1	3
8	1524468	Electronic board	1	1	3
9	J2FTCS435	O-ring - silicone	1	1	1
10	X3GJBP484	Screw PT KA30x20 WN1411 galvanised steel, cross-head	7	1	3
11	J4BRND039	Fibre seal	7	1	1
12	1524465	Cable assembly (length: 6m)	1	1	3
	1526699	Cable assembly (length: 12m)	Option	1	3
	910004244	Cable assembly (length: 18m)	Option	1	3
13	130001030	Powder hose PEO 11mm green	6	m	1
14	1411501	Powder connector assembly	1	1 or 10	1
15	1525793	Vertical powder pipe assembly see § 10.4 page 44	1	1	3
16	1525908	Handle assembly (see § 10.3 page 43)	1	1	3
17	1313078	"Small-size" hand-rest (included in item 16)	1	1	1

(*)

Level 1: Standard preventive maintenance

Level 2: Corrective maintenance

Level 3: Exceptional maintenance.

10.2. Gun assembly

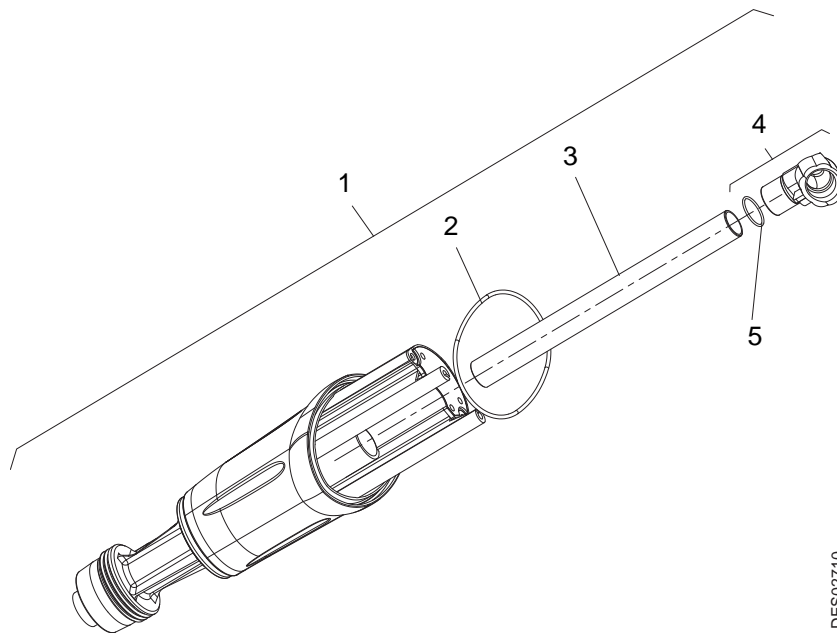

DES02710

Item	P/N	Description	Qty	Unit of sale	Maintenance level for spare parts (*)
1	1524464	Gun assembly	1	1	3
2	J2CTCN115	O-ring	1	1	1
3	1409919	Horizontal powder pipe	1	1	1
4	1526475	Elbow assembly	1	1	1
5	J2CTCN363	O-ring (included in item 4)	1	1	1

(*)

Level 1: Standard preventive maintenance

Level 2: Corrective maintenance

Level 3: Exceptional maintenance.

10.3. Handle assembly

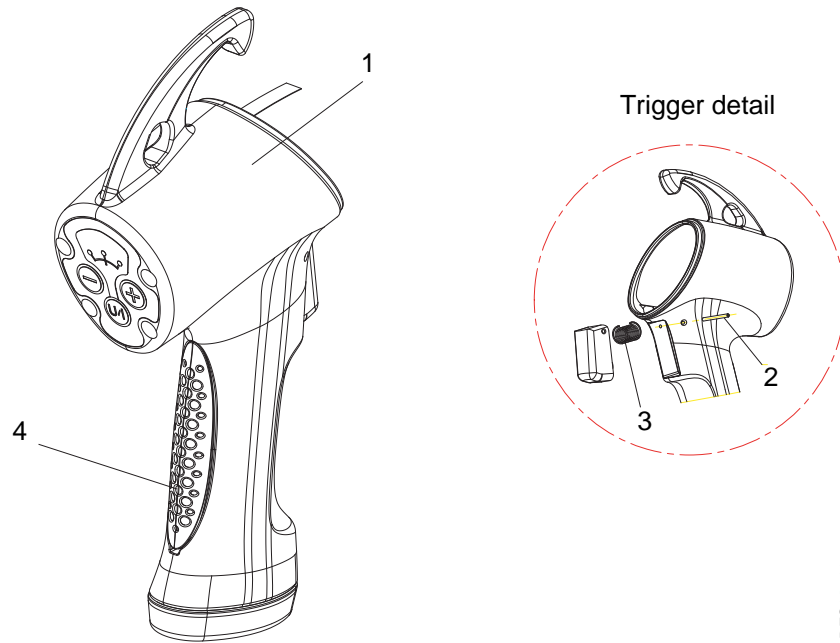

DES02711

Item	P/N	Description	Qty	Unit of sale	Maintenance level for spare parts (*)
1	1525908	Handle assembly	1	1	3
2	X2DGSP017	Pin	1	1	3
3	1408849	Trigger spring	1	1	3
4	1313078	"Small-size" hand-rest	1	1	1

(*)

Level 1: Standard preventive maintenance

Level 2: Corrective maintenance

Level 3: Exceptional maintenance.

10.4. Vertical powder pipe assembly

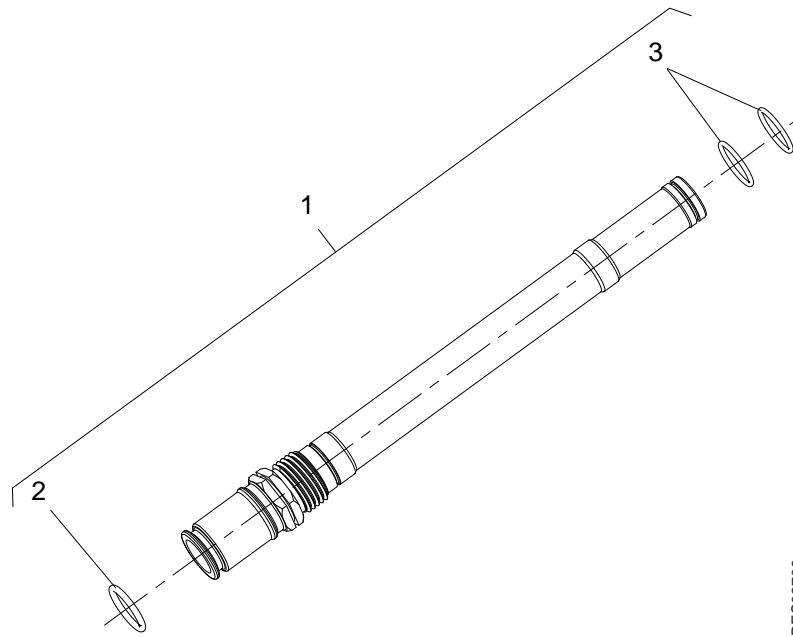

DIES02709

Item	P/N	Description	Qty	Unit of sale	Maintenance level for spare parts (*)
1	1525793	Vertical powder pipe assembly	1	1	3
2	J2FENV160	O-ring - FEP	1	1	1
3	J2FTDF125	O-ring - Viton	2	1	1

(*)

Level 1: Standard preventive maintenance

Level 2: Corrective maintenance

Level 3: Exceptional maintenance.

10.5. Nozzles

10.5.1. Fan spray nozzle

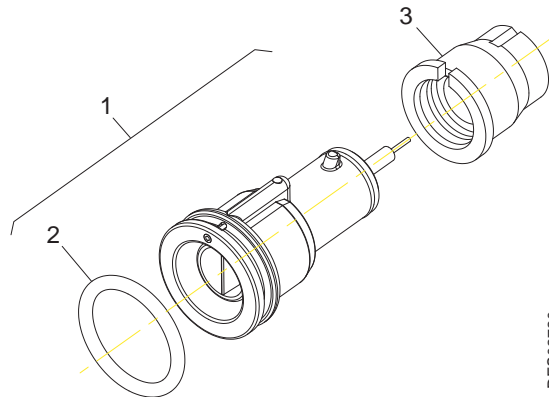

Item	P/N	Description	Qty	Unit of sale	Maintenance level for spare parts (*)
1	1525492	Fan spray nozzle assembly without deflector	1	1	1
2	1412250	Conductor O-ring (included in item 1)	1	1	1
3	1313519	Medium fan spray deflector (white)	Option	1	1
	1311409	Narrow fan spray deflector (light grey)	Option	1	1
	1311793	Wide fan spray deflector (red)	Option	1	1
	1315957	Standard fan spray deflector (yellow)	1	1	1

(*)

Level 1: Standard preventive maintenance

Level 2: Corrective maintenance

Level 3: Exceptional maintenance.

10.5.2. Round spray nozzle

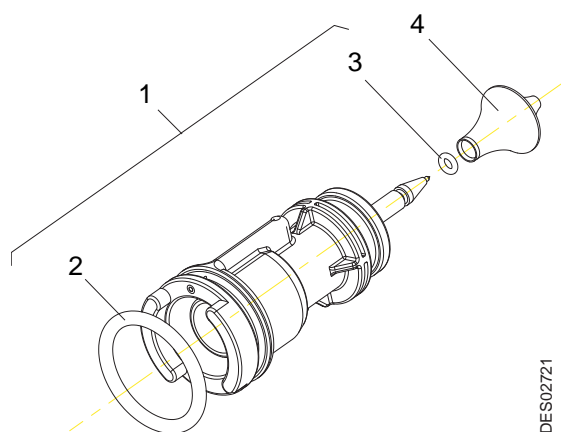

Item	P/N	Description	Qty	Unit of sale	Maintenance level for spare parts (*)
1	1525493	Round spray nozzle assembly without deflector	1	1	1
2	1412250	Conductor O-ring (included in item 1)	1	1	1
3	J2CTPC020	O-ring - PC 851 (included in item 1)	1	1	1
4	1409259	Round spray deflector, Dia.: 16 mm (white)	1	1	1
	900008026	HD Round spray deflector, Dia.: 12 mm (grey)	Option	1	1
	1411500	Round spray deflector, Dia.: 12 mm (white)	Option	1	1
	1409260	Round spray deflector, Dia.: 20 mm (white)	Option	1	1
	900008027	HD Round spray deflector, Dia.: 20 mm (blue)	Option	1	1
	1411993	Round spray deflector, Dia.: 25 mm (white)	Option	1	1

(*)

Level 1: Standard preventive maintenance

Level 2: Corrective maintenance

Level 3: Exceptional maintenance.



WARNING : The deflectors high durability (HD) are recommended when a powder more abrasive is used.

10.5.3. Extended nozzles, flat spray

Length: 150 mm

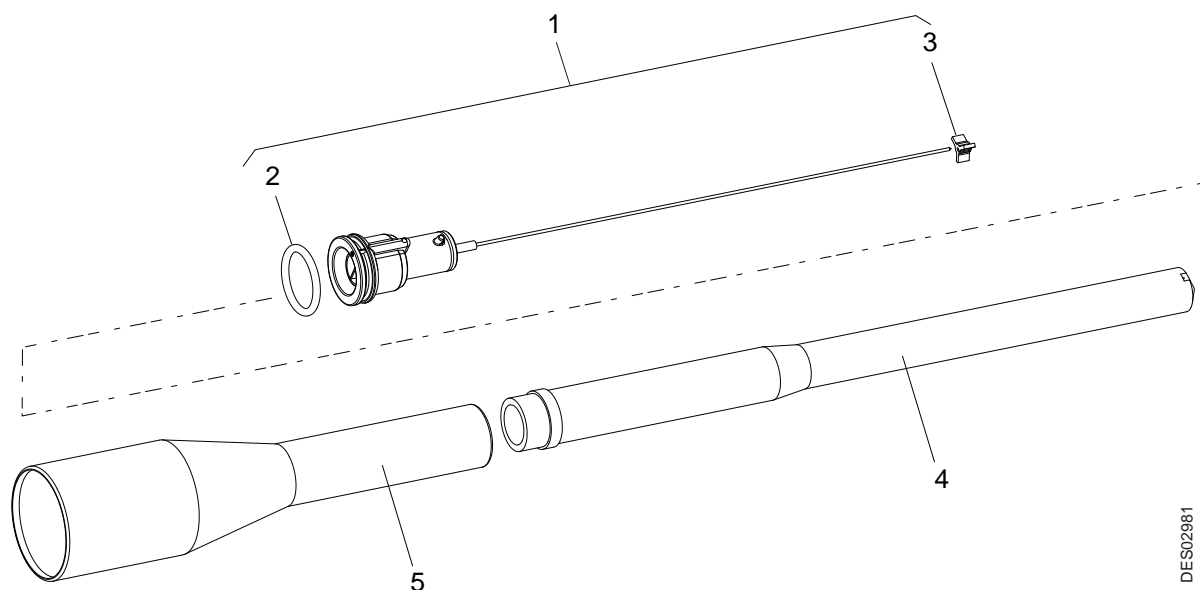

DES02981

Item	P/N	Description	Qty	Unit of sale	Maintenance level for spare parts (*)
	910004126	Extended nozzle, length: 150 mm	1	1	3
1	910004211	Extended nozzle set	1	1	3
2	1412250	Conductor O-ring (included in item 1)	1	1	1
3	900002407	Electrode centering part (included in item 1)	1	1	1
4	900003076	Flat spray deflector	1	1	1
5	900002406	Nozzle nut	1	1	3

Length: 300 mm

Item	P/N	Description	Qty	Unit of sale	Maintenance level for spare parts (*)
	910004125	Extended nozzle, length: 300 mm	1	1	3
1	910004210	Extended nozzle set	1	1	3
2	1412250	Conductor O-ring (included in item 1)	1	1	1
3	900002407	Electrode centering part (included in item 1)	1	1	1
4	900002405	Flat spray deflector	1	1	1
5	900002406	Nozzle nut	1	1	3

(*)

Level 1: Standard preventive maintenance

Level 2: Corrective maintenance

Level 3: Exceptional maintenance.

10.5.4. Extended nozzles, round spray

Length: 150 mm

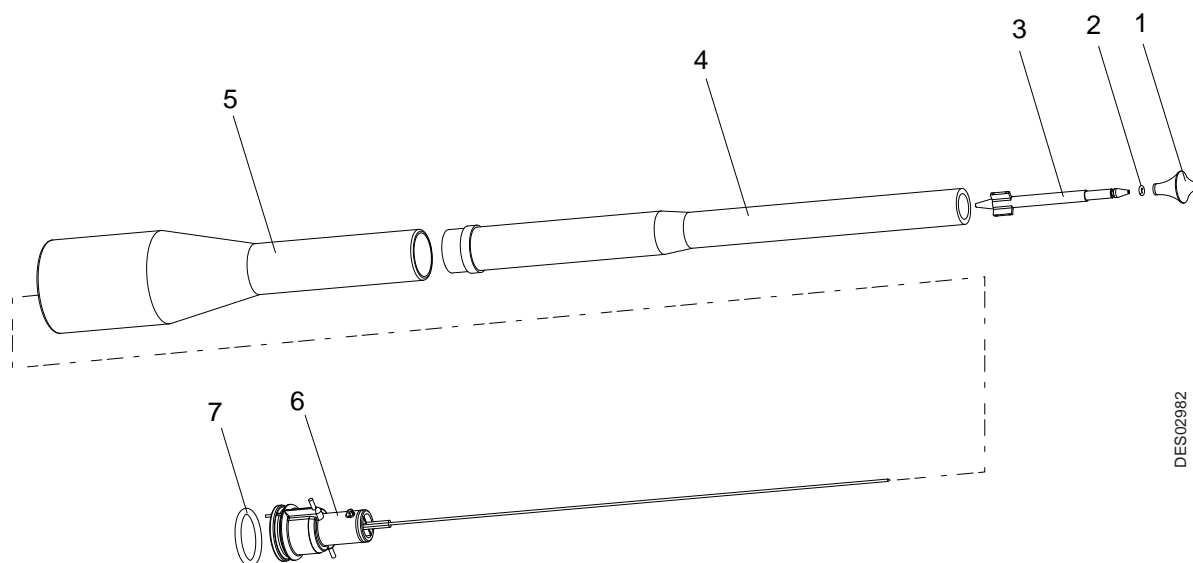

DES02982

Item	P/N	Description	Qty	Unit of sale	Maintenance level for spare parts (*)
	910006971	Round spray extended nozzle length: 150 mm	1	1	3
1	1409259	Round spray deflector, Dia.: 16 mm (white)	1	1	1
2	J2CTPC020	O-ring - PC 851	1	1	1
3	900005139	Round spray deflector support	1	1	3
4	900005148	Extend of deflector support	1	1	3
5	900002406	Nozzle nut	1	1	3
6	900003075	Nozzle electrode support	1	1	3
7	1412250	Conductor O-ring	1	1	1

Length: 300 mm

Item	P/N	Description	Qty	Unit of sale	Maintenance level for spare parts (*)
	910006970	Round spray extended nozzle length: 300 mm	1	1	3
1	1409259	Round spray deflector, Dia.: 16 mm (white)	1	1	1
2	J2CTPC020	O-ring - PC 851	1	1	1
3	900005139	Round spray deflector support	1	1	3
4	900005138	Extend of deflector support	1	1	3
5	900002406	Nozzle nut	1	1	3
6	900002678	Nozzle electrode support	1	1	3
7	1412250	Conductor O-ring	1	1	1

(*) **Level 1: Standard preventive maintenance**
Level 2: Corrective maintenance
Level 3: Exceptional maintenance.

10.6. Equipment



P/N	Description	Qty	Unit of sale	Maintenance level for spare parts (*)
1523297	CRN 457 control module	1	1	3
E4PCAL206	"Europe" Main power cable	1	1	3
E4PCAL459	"US" Main power cable	-	1	3
E4PCAL501	"UK" Main power cable	-	1	3
E4PTFS572	Male PLC plug, 19 contacts	1	1	3
E4PTFD574	Crimp contact	18	1	3
	Plug specific tools			
W6EDEM089	Removal tool, sprayer plug	-	1	-
W6EDEM090	Removal tool, PLC plug	-	1	-

Manual flush filter

P/N	Description	Qty	Unit of sale	Maintenance level for spare parts (*)
R4DFCM199	Manual flush filter	1	1	3
F6RLCS204	Male union	2	1	2
R4DACC200	Filter cartridge	-	1	1
X3AVSY119	Screw Chc M4 x12 steel 8/8 zinc plated	2	1	3
X2BDMU004	Washer M4 U zinc plated steel	2	1	3

(*)

Level 1: Standard preventive maintenance

Level 2: Corrective maintenance

Level 3: Exceptional maintenance.

11. "FM approved" Configurations

Guns		HV generator molding	Spray nozzle				Cable length				Option						
Model/N	P/N Drawing	P/N 1524464	JR		JP		6 M	12 M	18 M	30 M	Extended Nozzle 150 mm P/N 910004126	Extended Nozzle 300 mm P/N 910004125	Extended Nozzle 150 mm P/N 910006971	Extended Nozzle 300 mm P/N 910006970	Counter Electrode P/N 1527017	Adjustable nozzle P/N 1527292	Electro-pneumatic control module CRN 457 P/N 1523297
			12 mm	16 mm	20 mm	25 mm											
Mach-Jet Gun	1524463	×	×	×	×	×	×	×	×		×	×	×	×			×

DES03278

Référence Mach-Jet Gun Mach-Jet Gun P/N:

6 M -----> 1524463

12 M -----> 1524463-12

18 M -----> 1524463-18

Références des Equipements de Pulvérisation / Spraying pattern P/N equipment:

	JR12	JR16	JR20	JR25
Buse / Nozzle	1525493	1525493	1525493	1525493
Défecteur / Deflector	1411500	1409259	1409260	1411993

	JP étroit / narrow	JP medium / medium	JP large / large	JP Standard / standard
Buse / Nozzle	1525492	1525492	1525492	1525492
Défecteur / Deflector	1311409	1313519	1311793	1315957