



DOCUMENTATION - DOKUMENTATION - DOCUMENTACIÓN

POMPE A PALETTE / SHOVEL PUMP / SCHÖPFKOLBENPUMPE / BOMBA CON PALETA

**THOR 60-C910-HD**

Notice / Manual / Betriebsanleitung / Libro : 582.048.110 - 1605

Date / Datum / Fecha : 27/05/16

Annule / Supersede / Ersetzt / Anula :

Modif. / Änderung :

**NOTICE ORIGINALE / TRANSLATION FROM THE ORIGINAL MANUAL**  
**/ ÜBERSETZUNG DER ORIGINAL BETRIEBSANLEITUNG**  
**/ TRADUCCIÓN DEL MANUAL ORIGINAL**

**IMPORTANT : Lire attentivement tous les documents avant le stockage, l'installation ou la mise en service du matériel concerné (à usage strictement professionnel).**

**Before assembly and start-up, please read and clearly understand all the documents relating to this equipment (professional use only).**

**WICHTIGER HINWEIS: Vor Lagerung, Installation oder Inbetriebnahme des Geräts bitte sämtliche Dokumente sorgfältig lesen (Einsatz nur von geschultem Personal).**

**IMPORTANTE : Lea con atención todos los documentos antes de almacenar, instalar o poner en marcha el equipo (uso exclusivamente profesional).**

PHOTOS ET ILLUSTRATIONS NON CONTRACTUELLES. MATÉRIELS SUJETS A MODIFICATION(S) SANS PREAVIS.

THE PICTURES AND DRAWINGS ARE NON CONTRACTUAL. WE RESERVE THE RIGHT TO MAKE CHANGES WITHOUT PRIOR NOTICE.

ALLE IN DIESEM DOKUMENT ENTHALTENEN SCHRIFTLICHEN ANGABEN UND ABBILDUNGEN STELLEN DIE NEUESTEN

PRODUKTINFORMATIONEN DAR. WIR BEHALTEN UNS DAS RECHT VOR, JEDERZEIT OHNE VORANKÜNDIGUNG ÄNDERUNGEN VORZUNEHMEN.

LAS FOTOGRAFÍAS E ILUSTRACIONES NO SON VINCULANTES. LOS MATERIALES ESTÁN SUJETOS A CAMBIOS SIN PREVIO AVISO.

**KREMLIN - REXSON**

150, avenue de Stalingrad

93 245 - STAINS CEDEX - France

☎ : 33 (0)1 49 40 25 25      Fax : 33 (0)1 48 26 07 16

**www.kremlin-rexson.com**



# INSTALLATION AND SAFETY INSTRUCTIONS

## TRANSLATION OF THE ORIGINAL MANUAL

**IMPORTANT** : Before assembly and start-up, please read and clearly understand all the documents relating to this equipment (professional use only).

*THE PICTURES AND DRAWINGS ARE NON CONTRACTUAL. WE RESERVE THE RIGHT TO MAKE CHANGES WITHOUT PRIOR NOTICE.*

### **KREMLIN - REXSON**

150, avenue de Stalingrad

93 245 - STAINS CEDEX – France

**☎** : 33 (0)1 49 40 25 25      *Fax* : 33 (0)1 48 26 07 16

**[www.kremlin-rexson.com](http://www.kremlin-rexson.com)**

# 1. SAFETY INSTRUCTIONS

## GENERAL SAFETY INSTRUCTIONS



**CAUTION :** The equipment can be dangerous if you do not follow our instructions concerning installation and servicing described in this manual and in accordance with applicable European standards and local national safety regulations.

Please carefully read all the instruction literature before operating your equipment.

**Only trained operators can use the equipment** (To acquire an essential training, please contact the "KREMLIN REXSON University" training center - Stains).

The foreman must ensure that the operator has understood the safety instructions for this equipment as well as the instructions in the manuals for the different parts and accessories.

Read carefully all instruction manuals, label markings before operating the equipment.



















Incorrect use may result in injury. This equipment is for professional use only. It must be used only for what it has been designed for. Never modify the equipment. The parts and accessories supplied must be regularly inspected. Defective or worn parts must be replaced.

**Guards (motor cover, coupling shields, connectors,...) have been designed for a safe use of the equipment.**  
**The manufacturer will not be held responsible for bodily injury or failure and / or property damage due to destruction, the overshadowing or the partial or total removal of the guards.**

**Never exceed the equipment components' maximum working pressure.**

Comply with regulations concerning safety, fire risks, electrical regulations in force in the country of final destination of the material. Use only products or solvent compatible with the parts in contact with the material (refer to data sheet of the material manufacturer).

## PICTOGRAMS

					
NIP HAZARD	WARNING MOVING ELEVATOR	WARNING MOVING PARTS	WARNING MOVING SHOVEL	DO NOT EXCEED THIS PRESSURE	HIGH PRESSURE HAZARD
					
RELIEF OR DRAIN VALVE	WARNING HOSE UNDER PRESSURE	WEAR GLASSES OBLIGATORY	WEAR OF GLOVES IS OBLIGATORY	PRODUCT VAPOR HAZARDS	WARNING HOT PARTS OR AREAS
					
ELECTRICAL HAZARD	WARNING FIRE HAZARDS	EXPLOSION HAZARDS	GROUNDING	WARNING (USER)	WARNING SERIOUS INJURIES

## FIRE - EXPLOSION - SPARKS - STATIC ELECTRICITY HAZARDS

A poor earth connection, inadequate ventilation, sparks or static electricity can cause an explosion or fire. to avoid these risks when using or servicing KREMLIN REXSON equipment, the following safety procedures must be followed :



- ensure a good earth connection and ground the parts to be handled i.e. solvents, materials, components and equipment,
- ensure adequate ventilation,
- keep working area clean and free from waste solvents, chemicals, or solid waste i.e. rags, paper and empty chemicals drums,
- never use electrical switches / power if in an atmosphere of volatile solvent vapour,
- stop working immediately in case of electrical arcs,
- never store chemicals and solvents in the working area.
- use paint whose flash point is the highest possible to prevent from any formation of gas and inflammable vapours (refer to materials' safety instructions),
- install a cover on the drums to reduce the diffusion of gas and vapours in the spraybooth.

## TOXIC PRODUCT HAZARDS

Toxic products or vapours can cause severe injury not only through contact with the body, but also if the products are ingested or inhaled. It is imperative :



- to know the material products and their risks,
- notified or hazardous materials must be stored in accordance with the regulations,
- the material must be stored in an appropriate container, never place materials in a container where there is a risk of spillage or leakage,
- a procedure must be applied for the safe disposal of waste material. It must comply with all prevailing regulations and legislations of the country where the equipment is to be used,
- protective clothing should always be worn in compliance with the material manufacturers' recommendations,
- depending on the application and chemical safety instructions, safety glasses, hearing protective earplug, gloves, foot wear, protective masks and possible breathing equipment should be worn to comply with the regulations (Refer to chapter "Safety equipment of KREMLIN selection guide).



### **CAUTION!**



It is forbidden to use material containing high concentrations of halogenated hydrocarbon solvents with **aluminium or zinc fillers** .Non-compliance with the instructions may cause explosion risk causing serious or fatal injury.

## EQUIPMENT REQUIREMENTS

**Guards (motor cover, coupling shields, connectors,...) have been designed for a safe use of the equipment.**

**The manufacturer will not be held responsible for bodily injury or failure and / or property damage due to destruction, the overshadowing or the partial or total removal of the guards.**

### **PUMP**



Before carrying out any work, it is imperative to read and clearly understand the disassembly and reassembly instructions before servicing. The operator must understand the equipment and the safety instructions. These instructions are available in the equipment manuals.



The air motor is designed to be mounted with a pump. Never modify any components or couplings. When operating, please keep hands away from moving parts. Before starting up the equipment, please read the PRESSURE RELIEF instructions. Please ensure that any relief or drain valves fitted are in good working order.

### **HOSES**

- Keep hoses out of circulation areas, moving parts or hot surfaces,
- Never expose product hoses to temperature higher than + 60°C / 140° F or lower than 0°C / 32° F,
- Never pull or use the hoses to move the equipment,
- Tighten all fittings as well as the hoses before operating the equipment,
- Check the hoses regularly; change them if they are damaged,
- Never exceed the working pressure (WP) indicated on the hose.

## USED PRODUCTS

Considering the wide variety of products that are available and can be used in our equipment it is impossible to check and make recommendations for all chemical data, regarding the risks of possible chemical attack and their long term chemical reaction

KREMLIN REXSON can not be held liable for :

- Compatibility of wetted parts,
- Risks to staff and the surroundings,
- for worn or defective parts, for faulty equipment or units, or the quality of final product.

It is the responsibility of the user to know and prevent any possible risks such as toxic vapours, fires or explosions. He shall determine the risks of immediate reactions or pursuant to repeated exposures of the staff,

KREMLIN REXSON shall not be liable for physical injuries, direct or indirect material damages caused by the use of chemicals.

## 2. HANDLING



### ***Check the weight and the dimensions of the equipment***

***( refer to 'Technical features' section of the instruction manual***

If weight and dimensions are too important, the unloading must be carried out by means of a forklift or any other appropriate means with a qualified personnel and in a clear horizontal area to prevent from risks of damage injury or an accident.

The centre of gravity is not in the centre of the machine : carry out by hand a stability-test after having lifted the whole at 10 cm / 3.937" maximum.

After the unloading, the handling of the whole (eg: elevator pump) is carried out by means of a pallet truck taking the bottom part of the frame.

**Remark : Each pump motor is fitted with a ring. The ring is designed for the hoisting of one pump and can not be used for the handling of the complete machine.**

## 3. STORING

Storing before installation :

- Storing ambient temperature : 0 / +50 °C / 0 / +122°F
- Protect the whole against dust, water trickling, dampness and shocks.

Storing after installation :

- Operating temperature : +15 / +35 °C / +59 / +138.2° F
- Protect the whole against dust, water trickling, dampness and shocks.

## 4. INSTALLATION OF THE EQUIPMENT

The machine is installed on a stable horizontal floor (for eg a concrete flag).



**To avoid risks caused by static electricity, the equipment as well as its components must be grounded.**

- **For the pumping equipments** (pumps, pneumatic rams, frame...), a section wire of 2.5 mm<sup>2</sup> is fixed on the material. Use this wire to connect the material to "the general ground". In case of severe environments (mechanical protection of the wire of earthing insufficient, vibrations, mobile material...) where function damages at the ground are probable, the user have to replace the provided wire of 2.5 mm<sup>2</sup> by a device more adapted to its environment (wire with a more important section, bonding strip, fixing by thimble with eyelet...),

The continuity of the ground must be controlled by a qualified electrician. If the continuity of the ground is not ensured, check the terminal, the wire and the earthing point. **Never** use the material without have solved this problem.

- In the severe cases of environments (mechanical protection of the wire of earthing insufficient, vibrations, mobile material...) where damages of the function put at the ground are probable, the user will have to replace the wire of 2.5 mm<sup>2</sup> provided, by a device more adapted to its environment (wire of more important section, bonding strip, fixing by thimble with eyelet...),
- **The gun** must be 'grounded' via a material hose or an air hose. In case of spraying by means of a gun with cup, the air hose must be conductive,
- **The materials to be painted** must also be grounded.

**All the materials situated in the working area shall be grounded.**



- **Never store** more than necessary inflammable materials inside the working area,
- The materials must be stored into **approved drums** and grounded,
- Use only grounded **metals containers** for the use of cleaning solvents,
- **Cardboard and paper are prohibited.**

## 5. MARKING OF THE EQUIPMENT

Each equipment has a marking plate.

The plate consists of the name of the manufacturer, the equipment part number and important information for correct use of the equipment (air pressure, electric power,...).



<p align="center"><b>FR</b></p> <p><b>Pour une utilisation sûre, il est de votre responsabilité de :</b></p> <ul style="list-style-type: none"> <li>• Lire attentivement tous les documents contenus dans le CD joint avant la mise en service de l'équipement,</li> <li>• D'installer, d'utiliser, d'entretenir et de réparer l'équipement conformément aux préconisations de KREMLIN REXSON ainsi qu'aux réglementations nationales et/ou locales,</li> <li>• Vous assurez que les utilisateurs de cet équipement ont été formés, ont parfaitement compris les règles de sécurité et qu'ils les appliquent.</li> </ul>	<p align="center"><b>UK</b></p> <p><b>To ensure safe use of the machinery, it is your responsibility to:</b></p> <ul style="list-style-type: none"> <li>• Carefully read all documents contained on the enclosed CD before putting the machinery into service,</li> <li>• Install, use, maintain and repair the machinery in accordance with KREMLIN REXSON's recommendations and national and/or local regulations,</li> <li>• Make sure that the users of the machinery have received proper training and that they have perfectly understood the safety rules and apply them.</li> </ul>	<p align="center"><b>DE</b></p> <p><b>Eine sichere Nutzung setzt voraus, dass Sie: :</b></p> <ul style="list-style-type: none"> <li>• alle in der CD enthaltenen Dokumente vor der Inbetriebnahme der Anlage aufmerksam lesen,</li> <li>• die Anlage im Einklang mit den Empfehlungen von KREMLIN REXSON sowie mit den nationalen und/oder lokalen Bestimmungen installieren, verwenden, warten und reparieren,</li> <li>• sich vergewissern, dass die Nutzer dieser Anlage angemessen geschult wurden, die Sicherheitsbestimmungen verstanden haben und sie anwenden.</li> </ul>
<p align="center"><b>ES</b></p> <p><b>Para una utilización segura, será de su responsabilidad:</b></p> <ul style="list-style-type: none"> <li>• leer atentamente todos los documentos que se incluyen en el CD adjunto antes de la puesta en servicio del equipo,</li> <li>• instalar, utilizar, efectuar el mantenimiento y reparar el equipo con arreglo a las recomendaciones de KREMLIN REXSON y a la normativa nacional y/o local,</li> <li>• cerciorarse de que los usuarios de este equipo han recibido la formación necesaria, han entendido perfectamente las normas de seguridad y las aplican.</li> </ul>	<p align="center"><b>IT</b></p> <p><b>Per un uso sicuro, vi invitiamo a:</b></p> <ul style="list-style-type: none"> <li>• leggere attentamente tutta la documentazione contenuta nel CD allegato prima della messa in funzione dell'apparecchio,</li> <li>• installare, utilizzare, mantenere e riparare l'apparecchio rispettando le raccomandazioni di KREMLIN REXSON, nonché le normative nazionali e/o locali,</li> <li>• accertarvi che gli utilizzatori dell'apparecchio abbiano ricevuto adeguata formazione, abbiano perfettamente compreso le regole di sicurezza e le applichino.</li> </ul>	<p align="center"><b>PT</b></p> <p><b>Para uma utilização segura, é da sua responsabilidade:</b></p> <ul style="list-style-type: none"> <li>• Ler atentamente todos os documentos incluídos no CD em anexo antes de pôr o equipamento em funcionamento,</li> <li>• Proceder à instalação, utilização, manutenção e reparação do equipamento de acordo com as preconizações de KREMLIN REXSON, bem como com outros regulamentos nacionais e/ou locais aplicáveis,</li> <li>• Assegurar-se que os utilizadores do equipamento foram devidamente capacitados, compreenderam perfeitamente e aplicam as devidas regras de segurança.</li> </ul>
<p align="center"><b>NL</b></p> <p><b>Voor een veilig gebruik dient u:</b></p> <ul style="list-style-type: none"> <li>• alle document op de bijgevoegde cd aandachtig te lezen alvorens het apparaat in werking te stellen,</li> <li>• het apparaat te installeren, gebruiken, onderhouden en repareren volgens de door KREMLIN REXSON gegeven aanbevelingen en overeenkomstig de nationale en/of plaatselijke reglementeringen,</li> <li>• zeker te stellen dat de gebruikers van dit apparaat zijn opgeleid, de veiligheidsregels perfect hebben begrepen en dat zij die ook toepassen.</li> </ul>	<p align="center"><b>SE</b></p> <p><b>För en säker användning av utrustningen ansvarar ni för följande:</b></p> <ul style="list-style-type: none"> <li>• Läs noga samtliga dokument som finns på den medföljande cd-skivan innan utrustningen tas i drift.</li> <li>• Installera, använd, underhåll och reparera utrustningen enligt anvisningarna från KREMLIN REXSON och enligt nationella och/eller lokala bestämmelser.</li> <li>• Försäkra er om att användare av denna utrustning erhållit utbildning, till fullo förstått säkerhetsföreskrifterna och tillämpar dem.</li> </ul>	<p align="center"><b>FI</b></p> <p><b>Käytön turvallisuuden varmistamiseksi velvollisuutesi on:</b></p> <ul style="list-style-type: none"> <li>• Lukea huolella kaikki CD:llä olevat asiakirjat ennen laitteiston käyttöönottoa,</li> <li>• Noudattaa laitteiston asennuksessa, käytössä, kunnossapidossa ja huollossa KREMLIN REXSON in suosituksia sekä kansallisia ja/tai paikallisia määräyksiä,</li> <li>• Varmistaa, että laitteiston käyttäjät ovat koulutettuja ja ymmärtävät täysin turvallisuusmääräykset ja miten niitä sovelletaan.</li> </ul>
<p align="center"><b>PL</b></p> <p><b>Dla zapewnienia bezpiecznego użytkowania na użytkownika spoczywa obowiązek:</b></p> <ul style="list-style-type: none"> <li>• Uważnego zapoznania się ze wszystkimi dokumentami znajdującymi się na załączonej płycie CD przed pierwszym uruchomieniem urządzenia,</li> <li>• Instalowania, użytkowania, konserwacji i naprawy urządzenia zgodnie z zaleceniami firmy KREMLIN REXSON oraz z przepisami miejscowymi,</li> <li>• Upewnienia, że wszyscy przeszkoleni użytkownicy urządzenia zrozumieli zasady bezpieczeństwa i stosują się do nich.</li> </ul>	<p align="center"><b>CS</b></p> <p><b>Pro bezpečné používání jste povinni:</b></p> <ul style="list-style-type: none"> <li>• Před uvedením zařízení do provozu si pozorně přečíst veškeré dokumenty obsažené na příloženém CD,</li> <li>• Nainstalovat, používat, udržovat a opravovat zařízení v souladu s pokyny firmy KREMLIN REXSON a s národními a/nebo místními legislativními předpisy,</li> <li>• Ujistit se, že uživatelé tohoto zařízení byli vyškoleni, že dokonale pochopili bezpečnostní pravidla a že je dodržují.</li> </ul>	<p align="center"><b>RU</b></p> <p><b>Для целей безопасного использования необходимо:</b></p> <ul style="list-style-type: none"> <li>• Ознакомиться со всеми документами, содержащимися в прилагаемом компакт-диске до ввода оборудования в эксплуатацию;</li> <li>• Устанавливать, использовать, производить техническое обслуживание и ремонт оборудования в соответствии с рекомендациями KREMLIN REXSON и национальным и/или местным законодательством;</li> <li>• Убедиться, что пользователи настоящего оборудования прошли подготовку, надлежащим образом усвоили правила безопасности и обеспечивают их соблюдение.</li> </ul>

Déclaration(s) de conformité au verso de ce document / Declaration(s) of conformity at the back of this document / Konformitätserklärung(en) auf der Rückseite dieser Unterlage / Declaración (es) de conformidad en el reverso de este documento / Dichiarazione/i di conformità sul retro del presente documento / Declaração(ões) de conformidade no verso do documento / Conformiteitsverklaring(en) op de keerzijde van dit document / Försäkran om överensstämmelse på omstående sida av detta dokument / Vaatimustenmukaisuusvakuutukset tämän asiakirjan kääntöpuolella / Deklaracja(e) zgodności na odwrocie dokumentu / Prohlášení o shodě se nachází/nacházejí na zadní straně tohoto dokumentu / Сертификат(ы) соответствия расположены на оборотной стороне настоящего документа



VALABLE JUSQU'AU 19 AVRIL 2016  
VALID UNTIL 19 APRIL 2016  
GÜLTIG BIS ZUM 19. APRIL 2016  
VALIDEZ HASTA EL 19 DE ABRIL DE 2016  
VALIDO FINO AL 19 APRILE 2016  
APLICÁVEL ATÉ 19 DE ABRIL DE 2016  
GELDIG TOT 19 APRIL 2016  
GÄLLER TILL OCH MED DEN 19 APRIL 2016  
VOIMASSA 19.4.2016 SAAKKA  
WAŻNOŚĆ DO 19 KWIETNIA 2016 R.  
PLATÍ DO 19. DUBNA 2016  
ДЕЙСТВИТЕЛЬНО ДО 19 АПРЕЛЯ 2016 ГОДА



DECLARATION CE DE CONFORMITE  
EC DECLARATION OF CONFORMITY  
EG KONFORMITÄTSEKTLÄRUNG  
DECLARACIÓN CE DE CONFORMIDAD  
DICHIARAZIONE CE DI CONFORMITÀ  
DECLARAÇÃO CE DE CONFORMIDADE  
EG-VERKLARING VAN OVEREENSTEMMING  
EG-FÖRSÄKRAN OM ÖVERENSSTÄMMELSE  
EY-VAATIMUKSEN MUKAISUUSVAKUUTUS  
DEKLARACJA ZGODNOŚCI CE  
CE PROHLÁŠENÍ O SHODĚ  
ДЕКЛАРАЦИЯ СООТВЕТСТВИЯ CE

Le fabricant / The manufacturer / Der Hersteller / El fabricante / Il produttore / O fabricante / De fabrikant / Tillverkare / Valmistaja / Producent / Výrobce / Изготовитель:	<b>KREMLIN REXSON</b> 150, avenue de Stalingrad 93 240 - STAINS - FRANCE Tél. 33 (0)1 49 40 25 25 - Fax : 33 (0)1 48 26 07 16
--	--

Déclare que le matériel désigné ci-après / Herewith declares that the equipment / erklärt hiermit, dass die / Declara que el material designado a continuación / Dichiaro che il materiale sottoindicato / Declara que o material a seguir designado / verklaart dat de hieronder aangeduide apparatuur / Kungör att den utrustning som anges här nedan / ilmoittaa, että alla mainitut laitteistot / Oświadczka, że wymienione poniżej urządzenia / Prohlašuje, že níže uvedené vybavení / Декларирует, что ниженазванное оборудование:

**POMPE A PALETTE / SHOVEL PUMP / SCHÖPFKOLBENPUMPE / BOMBA CON PALETA**

TENOR 666 cc
TENOR 910 cc
THOR 60-C910-HD

Est conforme à la législation d'harmonisation de l'Union applicable suivante / Is in conformity with the relevant Union harmonisation legislation / Erfüllt die einschlägigen Harmonisierungsrechtsvorschriften der Union / es conforme con la legislación de armonización pertinente de la Unión / è conforme alla pertinente normativa di armonizzazione dell'Unione / in overeenstemming met de desbetreffende harmonisatiewetgeving van de Unie / med den relevanta harmoniserade unionslagstiftningen / on asiaa koskevan unionin yhdenmukaistamislainsäädännön vaatimusten mukainen / jest zgodny z odpowiednimi wymaganiami unijnego prawodawstwa harmonizacyjnego / Shoduje se s následující příslušnou evropskou harmonizační legislativou / Соответствует следующим стандартизированным нормам Союза

Directive ATEX / ATEX Directive / ATEX Richtlinie / Directiva ATEX / Direttiva ATEX / Diretiva ATEX / ATEX-Richtlijn / ATEX-direktivet / ATEX-direktivi / Dyrektywa ATEX / Směrnice ATEX / Директива ATEX	<b>94/9/CE</b>
 II 2G IIB T3	

Dominique LAGOUGE

Directeur Général / Chief Executive Officer / Generaldirektor  
/ Director General / Direttore Generale / Director Geral / Algemeen  
Directeur / Generaldirektör / Pääjohtaja / Dyrektor Naczelny  
/ Dyrektor Generalny / Generální ředitel / Генеральный директор

Fait à Stains, le / Established in Stains, on / Geschehen zu Stains, am / En Stains, a / Redatto a Stains, / Vastgesteld te Stains, / Utformat i Stains, den / Stains, Ranska, / Sporządzono w Stains, dnia / Stains, dnia / Издано в г. Стен (Stains) 24/08/2011 - 08/24/2011

**VALABLE A PARTIR DU 20 AVRIL 2016**  
**VALID FROM 20 APRIL 2016**  
**GÜLTIG AB DEM 20. APRIL 2016**  
**VALIDEZ A PARTIR DEL 20 DE ABRIL DE 2016**  
**VALIDO A PARTIRE DAL 20 APRILE 2016**  
**APLICÁVEL A PARTIR DE 20 DE ABRIL DE 2016**  
**GELDIG VANAF 20 APRIL 2016.**  
**GÄLLER FRÅN OCH MED DEN 20 APRIL 2016**  
**VOIMASSA 20.4.2016 ALKAEN**  
**WAŻNOŚĆ OD 20 KWIETNIA 2016 R.**  
**PLATÍ OD 20. DUBNA 2016**  
**ДЕЙСТВИТЕЛЬНО С 20 АПРЕЛЯ 2016 ГОДА**



**DECLARATION UE DE CONFORMITE**  
**UE DECLARATION OF CONFORMITY**  
**EU- KONFORMITÄTSEKLRÄRUNG**  
**DECLARACIÓN UE DE CONFORMIDAD**  
**DICHIARAZIONE DI CONFORMITÀ UE**  
**DECLARAÇÃO UE DE CONFORMIDADE**  
**EU-CONFORMITEITSVERKLARING**  
**EU-FÖRSÄKRAN OM ÖVERENSSTÄMMESE**  
**EU- VAATIMUKSEN MUKAISUUSVAKUUTUS**  
**DEKLARACJA ZGODNOŚCI UE**  
**EU PROHLÁŠENÍ O SHODĚ**  
**ДЕКЛАРАЦИЯ О СООТВЕТСТВИИ НОРМАМ ЕС**

Le fabricant / The manufacturer / Der Hersteller / El fabricante / Il produttore / O fabricante / De fabrikant / Tillverkare / Valmistaja / Producent / Výrobce / Изготовитель:	<b>KREMLIN REXSON</b> 150, avenue de Stalingrad 93 240 - STAINS - FRANCE Tél. 33 (0)1 49 40 25 25 - Fax : 33 (0)1 48 26 07 16
--	--

Déclare que le matériel désigné ci-après / Herewith declares that the equipment / erklärt hiermit, dass die / Declara que el material designado a continuación / Dichiaro che il materiale sottoindicato / Declara que o material a seguir designado / verklaart dat de hieronder aangeduide apparatuur / Kungör att den utrustning som anges här nedan / ilmoittaa, että alla mainitut laitteistot / Oświadczka, że wymienione poniżej urządzenia / Prohlašuje, že níže uvedené vybavení / Декларирует, что ниженазванное оборудование:

**POMPE A PALETTE / SHOVEL PUMP / SCHÖPFKOLBENPUMPE / BOMBA CON PALETA**

TENOR 666 cc
TENOR 910 cc
THOR 60-C910-HD

Est conforme à la législation d'harmonisation de l'Union applicable suivante / Is in conformity with the relevant Union harmonisation legislation / Erfüllt die einschlägigen Harmonisierungsrechtsvorschriften der Union / es conforme con la legislación de armonización pertinente de la Unión / è conforme alla pertinente normativa di armonizzazione dell'Unione / in overeenstemming met de desbetreffende harmonisatiewetgeving van de Unie / med den relevanta harmoniserade unionslagstiftningen / on asiaa koskevan unionin yhdenmukaistamislainsäädännön vaatimusten mukainen / jest zgodny z odpowiednimi wymaganiami unijnego prawodawstwa harmonizacyjnego / Shoduje se s následující příslušnou evropskou harmonizační legislativou / Соответствует следующим стандартизированным нормам Союза

Directive ATEX / ATEX Directive / ATEX Richtlinie / Directiva ATEX / Direttiva ATEX / Diretiva ATEX / ATEX-Richtlijn / ATEX-direktivet / ATEX-direktivi / Dyrektywa ATEX / Směrnice ATEX / Директива ATEX 	<b>2014/34/UE</b>
Procédure d'évaluation de la conformité : Module A Documentation technique (Annexe VIII) archivée par : / Conformity assessment procedure: Module A Technical documentation (ANNEX VIII) recorded by: / Verfahren zur Konformitätsbewertung: Modul A Technische Unterlagen (ANLAGE VIII) archiviert durch: / Procedimiento de evaluación de la conformidad: Módulo A Documentación técnica (ANEXO VIII) archivada por: / Procedura di valutazione della conformità: Modulo A Documentazione tecnica (ALLEGATO VIII) archiviata a cura di: / Procedimento de avaliação da conformidade: Módulo A Documentação técnica (ANEXO VIII) arquivada por: / Conformiteitsbeoordelingsprocedure: Module A Technische documentatie (BIJLAGE VIII) gearhiveerd door: / Förfarande för bedömning av överensstämmelse: Modul A Teknisk dokumentation (BILAGA VIII) arkiverad av: / Vaatimustenmukaisuusarviointimenetelmä: moduuli A Tekninen dokumentaatio (LIITE VIII) arkistoitu: / Procedura oceny zgodności: Modul A Dokumentacja technicznej (ZAŁĄCZNIK VIII) zarchiwizowane przez: / Postup posuzování shody: Modul A Technická dokumentace (PŘÍLOHA VIII) archivována: / Процедура оценки соответствия: Модуль A Техническая документация (ПРИЛОЖЕНИЕ VIII), архивированная: ISSeP Zoning A. Schweitzer Rue de la Platerie B - 7340 COLFONTAINE BELGIQUE	

Dominique LAGOUGE

Directeur Général / Chief Executive Officer / Generaldirektor  
 / Director General / Direttore Generale / Director Geral / Algemeen  
 Directeur / Generaldirektör / Pääjohtaja / Dyrektor Naczelny  
 / Dyrektor Generalny / Generální ředitel / Генеральный директор

Fait à Stains, le / Established in Stains, on / Geschehen zu Stains, am / En Stains, a / Redatto a Stains, / Vastgesteld te Stains, / Utformat i Stains, den / Stains, Ranska, / Sporządzono w Stains, dnia / Stains, dnia / Издано в г. Стен (Stains) 08/04/2016 - 04/08/2016



**DEMONTAGE / REMONTAGE  
DISASSEMBLY / REASSEMBLY  
DEMONTAGE / MONTAGE  
DESMONTAJE / MONTAJE**

**POMPE A PALETTE / SHOVEL PUMP  
SCHÖPFKOLBENPUMPE / BOMBA CON PALETA  
THOR 60-C910-HD**

NOTICE ORIGINALE  
/ TRANSLATION OF THE ORIGINAL MANUAL  
/ ÜBERSETZUNG DER ORIGINAL BEDIENUNGSANLEITUNG  
/ TRADUCCIÓN DEL LIBRO ORIGINAL

**La pompe est soumise à la directive ATEX et ne doit en aucun cas être modifiée.  
Le non-respect de cette préconisation ne saurait engager notre responsabilité.  
/ The pump is manufactured under the ATEX agreement and can not be modified.  
KREMLIN REXSON will not be held responsible for any failure to comply with that instruction.**

**// Diese Pumpe hat die ATEX Zulassung, deswegen darf sie nie verändert werden.  
Bei Nichtbeachtung dieser Anordnung, können wir keine Verantwortung für eine einwandfreie, regelkonforme Funktion der Pumpe übernehmen.**

**/ La bomba es de conformidad a la directiva ATEX y no debe ser modificada, en ningún caso. Kremlin Rexson no se hace responsable de que esta preconización no sea respetada.**

**Des protecteurs (capot moteur, protecteur d'accouplement, carters,...) sont mis en place pour une utilisation sûre du matériel.**

**Le fabricant ne peut être tenu pour responsable en cas de dommages corporels ainsi que des pannes et / ou endommagement du matériel résultant de la destruction, de l'occultation ou du retrait total ou partiel des protecteurs.**

**/ Guards (air motor cover, coupling shields, housings ...) have been designed for safe use of the equipment. The manufacturer will not be held responsible for bodily injury or failure and / or damage to property due to removal or partial removal of the guards.**

**/ Schutzvorrichtungen an diesem Gerät, wie Motorhaube, Kupplungsschutz, Gehäuse, ggf. Erdungskabel, sowie weitere Vorrichtungen, wurden für eine sichere Benutzung dieses Gerätes entwickelt und angebracht. Der Hersteller lehnt jede Verantwortung für Körperschäden, Fehlfunktionen, Beschädigung der Geräte und jegliche andere Fehler ab, die durch die ganze oder teilweise Entfernung, Modifikation oder unsachgemäße Handhabung der Schutzvorrichtungen oder anderer Geräteteile entstehen.**

**/ Protectores (capó motor, protector de acoplamiento, cárteres,...) se colocan para una utilización segura del material. El fabricante no se hace responsable, en caso de daños personales, así como de las averías y / o daños del material, resultantes de la destrucción, la ocultación o la retirada total o parcial de los protectores.**

**Vous aurez besoin de / you need / Werkzeugaufstellung / Vd necesita :**



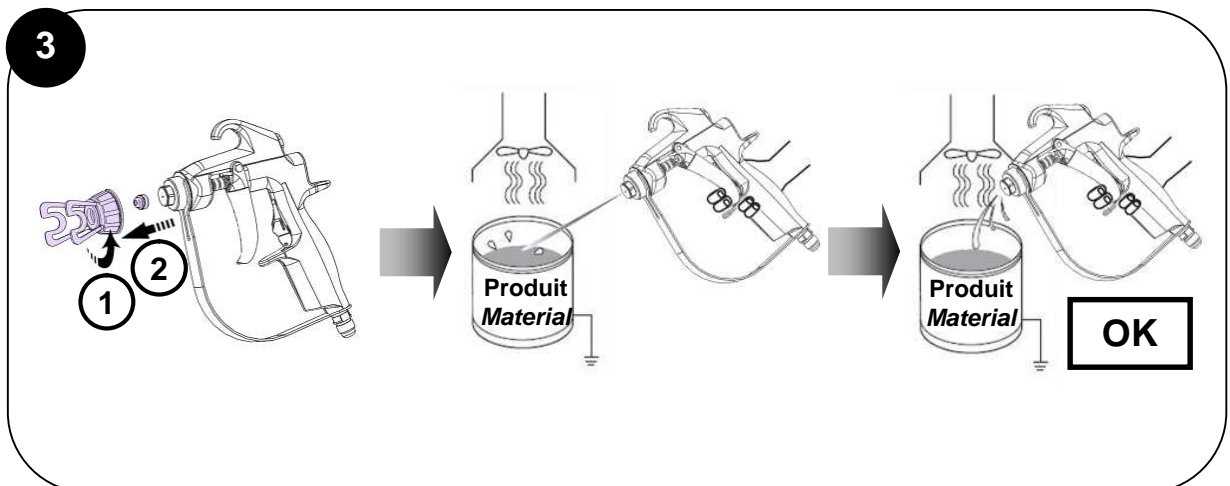
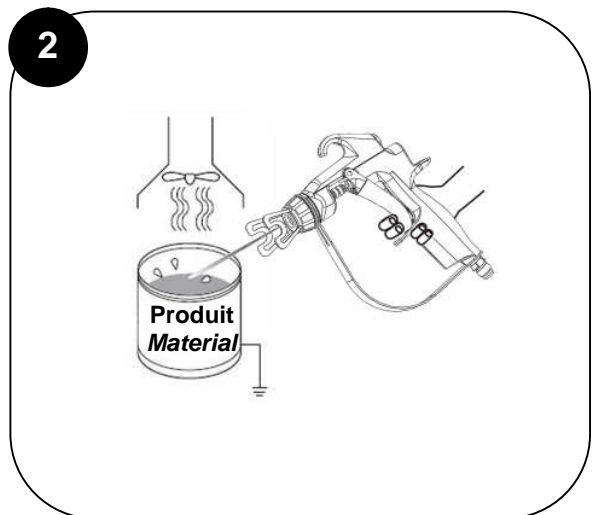
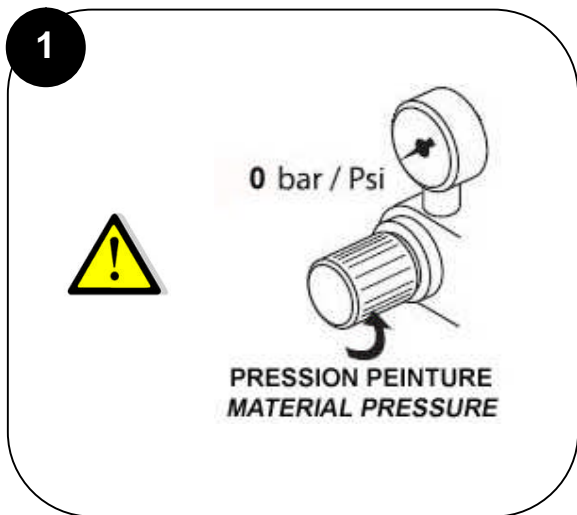
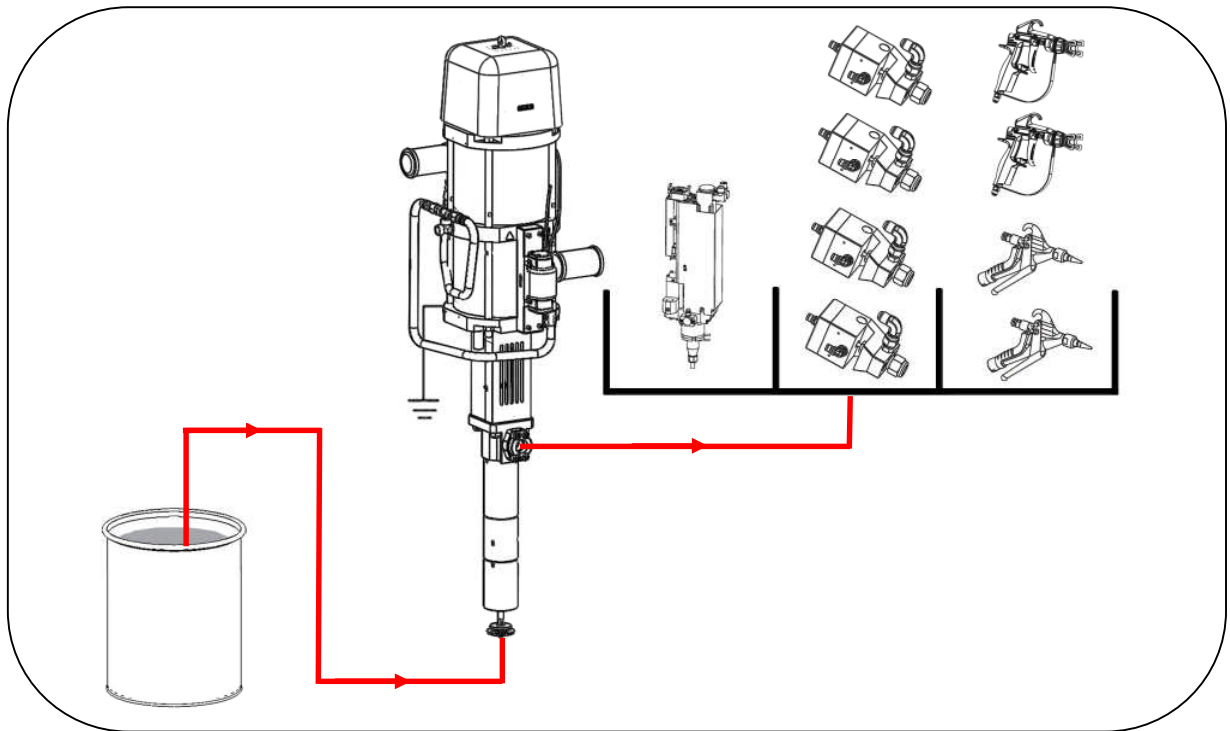

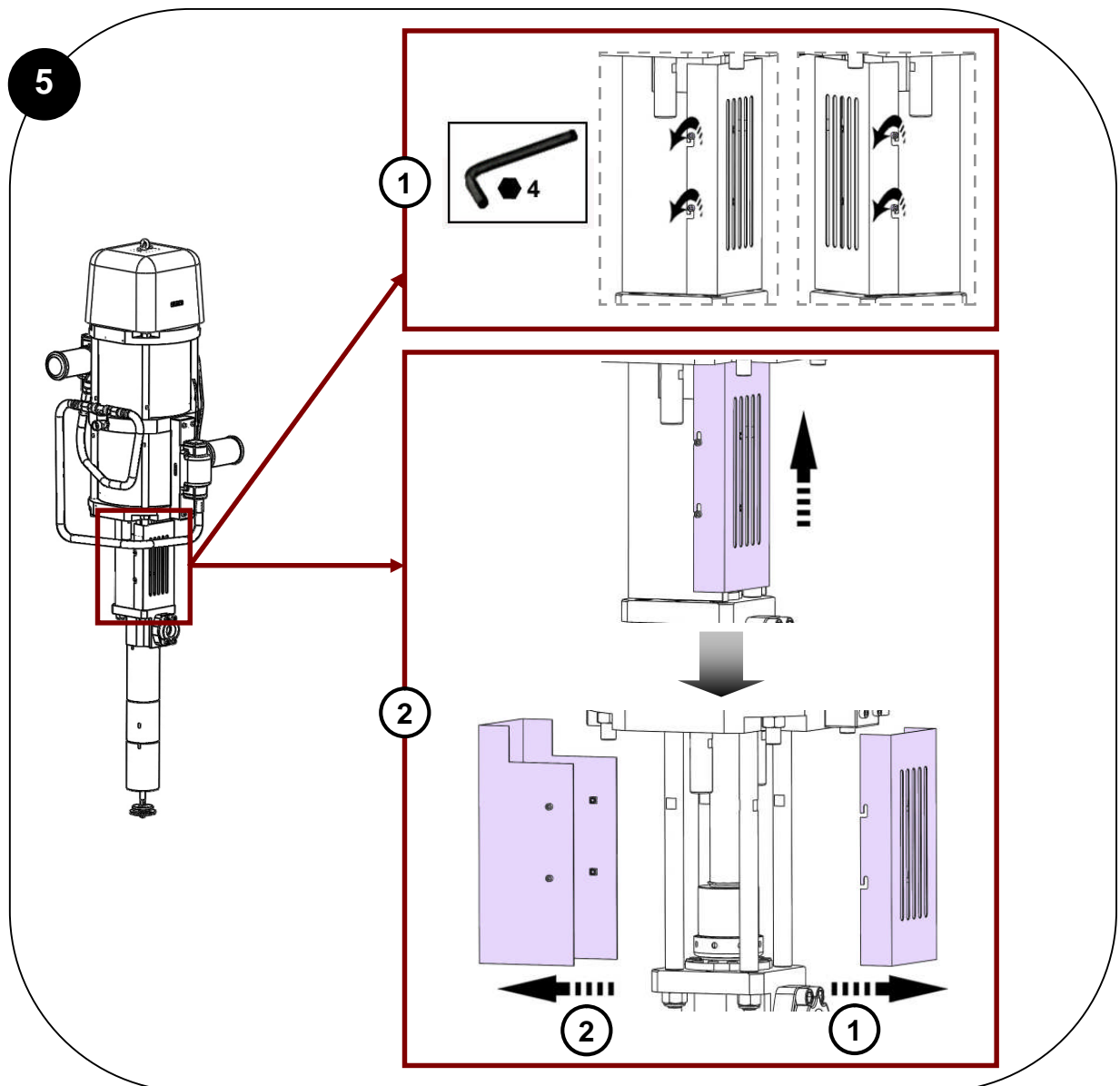
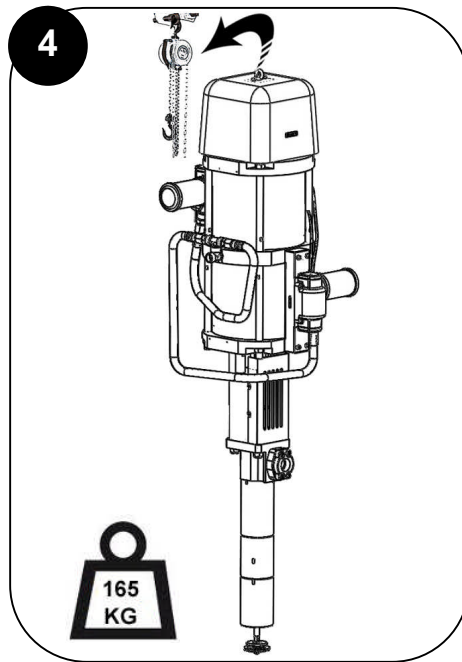

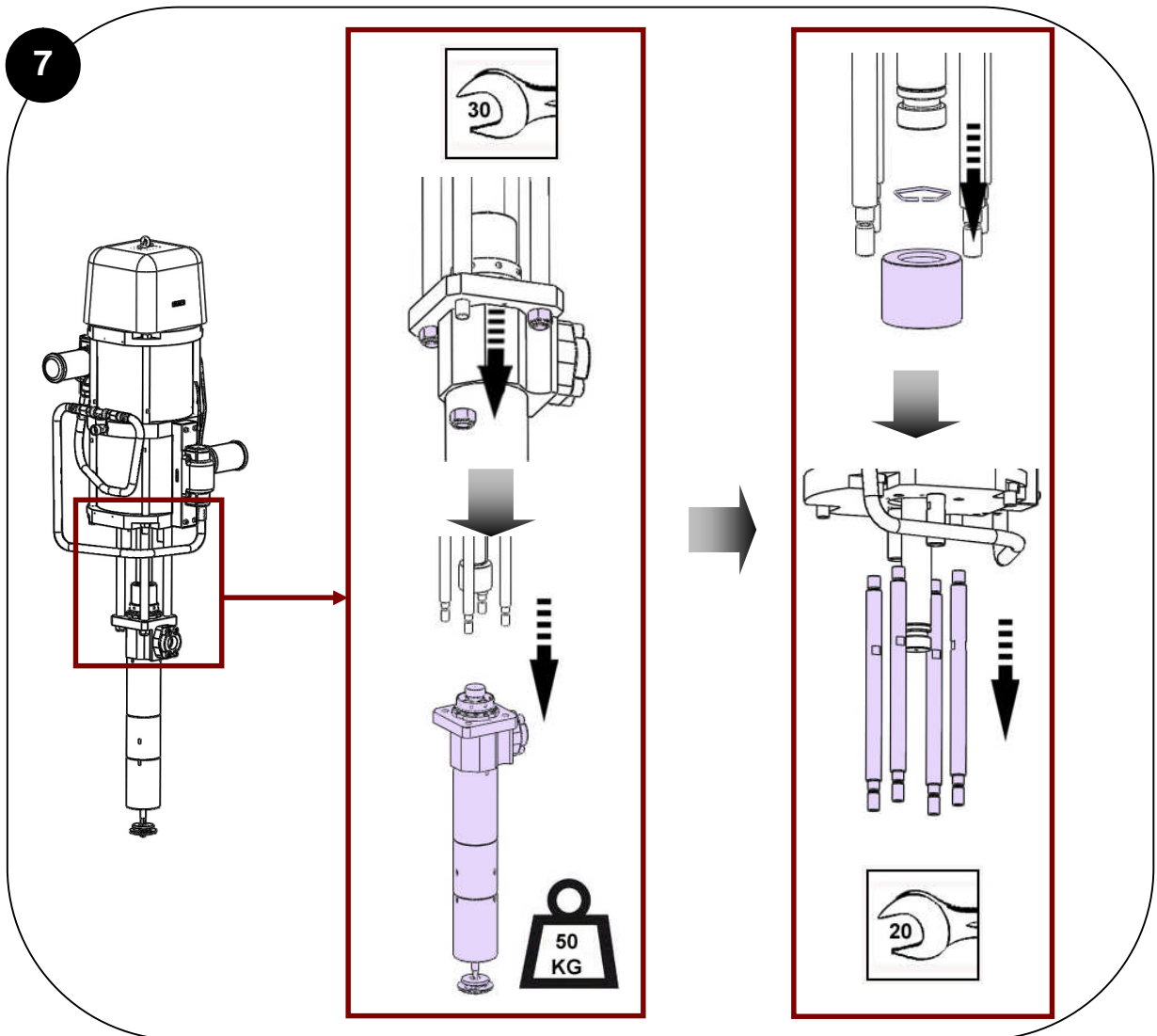
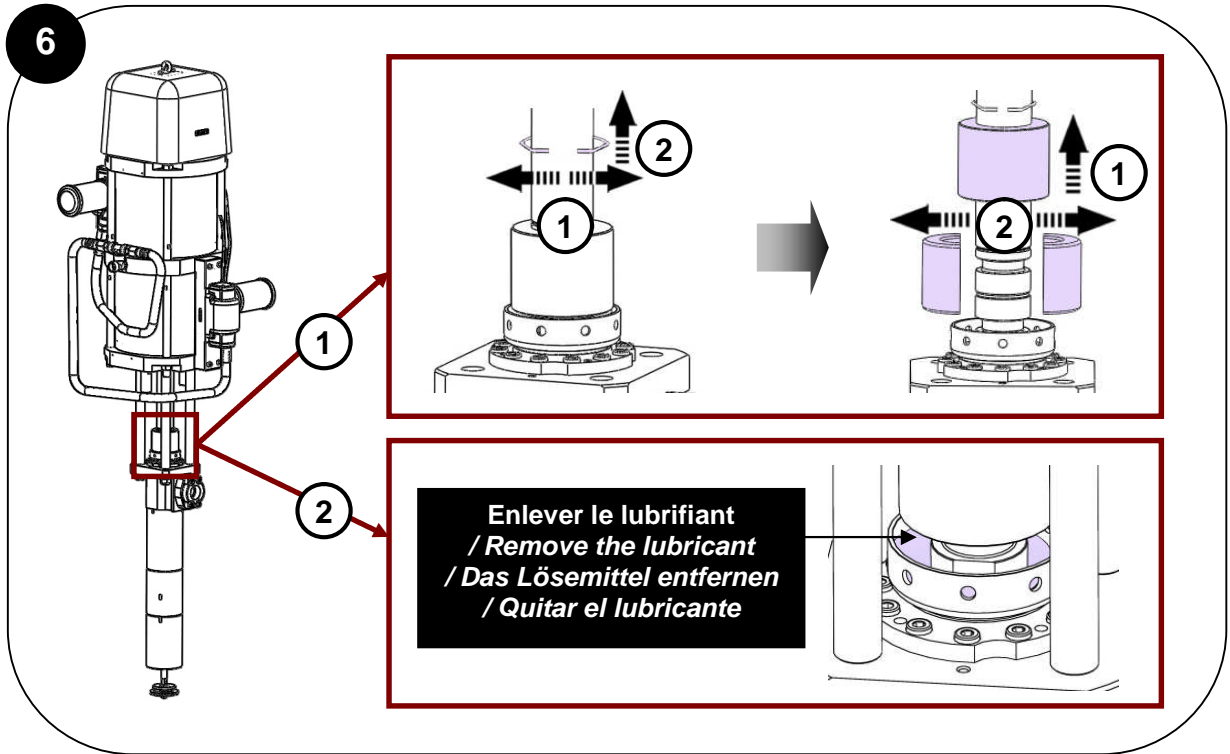

**8**

**Voir / Refer to  
Siehe / Consultar  
doc. / Dok.  
578.138.110**

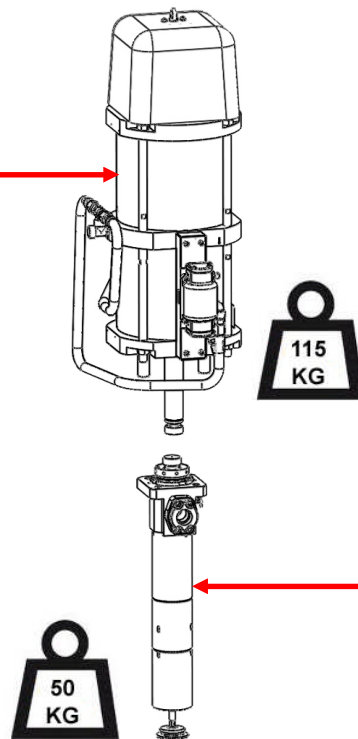

**Voir / Refer to  
Siehe / Consultar  
doc. / Dok.  
578.146.110**

**Des protecteurs (capot moteur, protecteur d'accouplement, carters,...) sont mis en place pour une utilisation sûre du matériel.**

**Le fabricant ne peut être tenu pour responsable en cas de dommages corporels ainsi que des pannes et / ou endommagement du matériel résultant de la destruction, de l'occultation ou du retrait total ou partiel des protecteurs.**

**/ Guards (air motor cover, coupling shields, housings ...) have been designed for safe use of the equipment. The manufacturer will not be held responsible for bodily injury or failure and / or damage to property due to removal or partial removal of the guards.**

**/ Schutzvorrichtungen an diesem Gerät, wie Motorhaube, Kupplungsschutz, Gehäuse, ggf. Erdungskabel, sowie weitere Vorrichtungen, wurden für eine sichere Benutzung dieses Gerätes entwickelt und angebracht. Der Hersteller lehnt jede Verantwortung für Körperschäden, Fehlfunktionen, Beschädigung der Geräte und jegliche andere Fehler ab, die durch die ganze oder teilweise Entfernung, Modifikation oder unsachgemäße Handhabung der Schutzvorrichtungen oder anderer Geräteteile entstehen.**

**/ Protectores (capó motor, protector de acoplamiento, cárteres,...) se colocan para una utilización segura del material. El fabricante no se hace responsable, en caso de daños personales, así como de las averías y / o daños del material, resultantes de la destrucción, la ocultación o la retirada total o parcial de los protectores.**

9

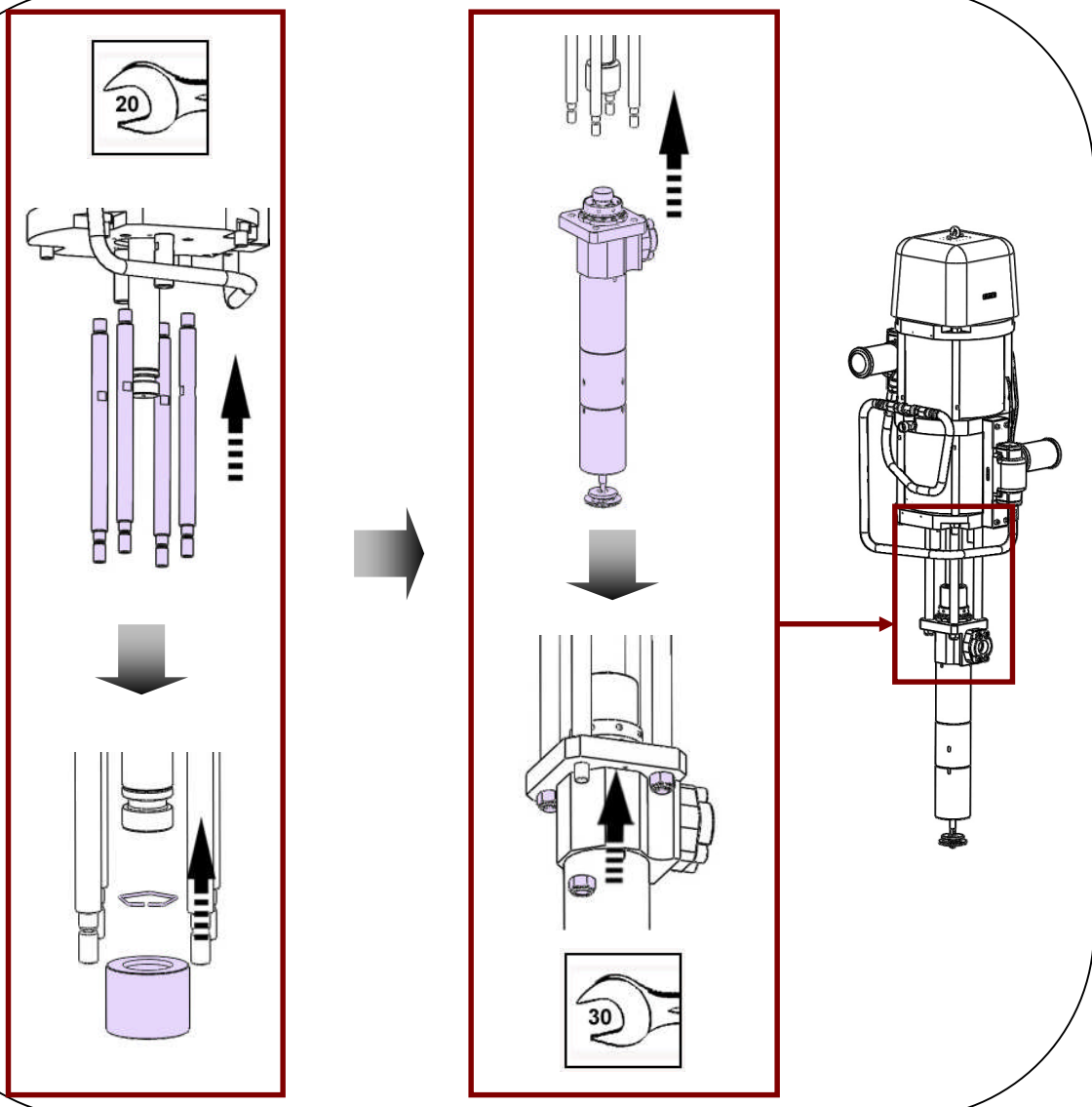

10

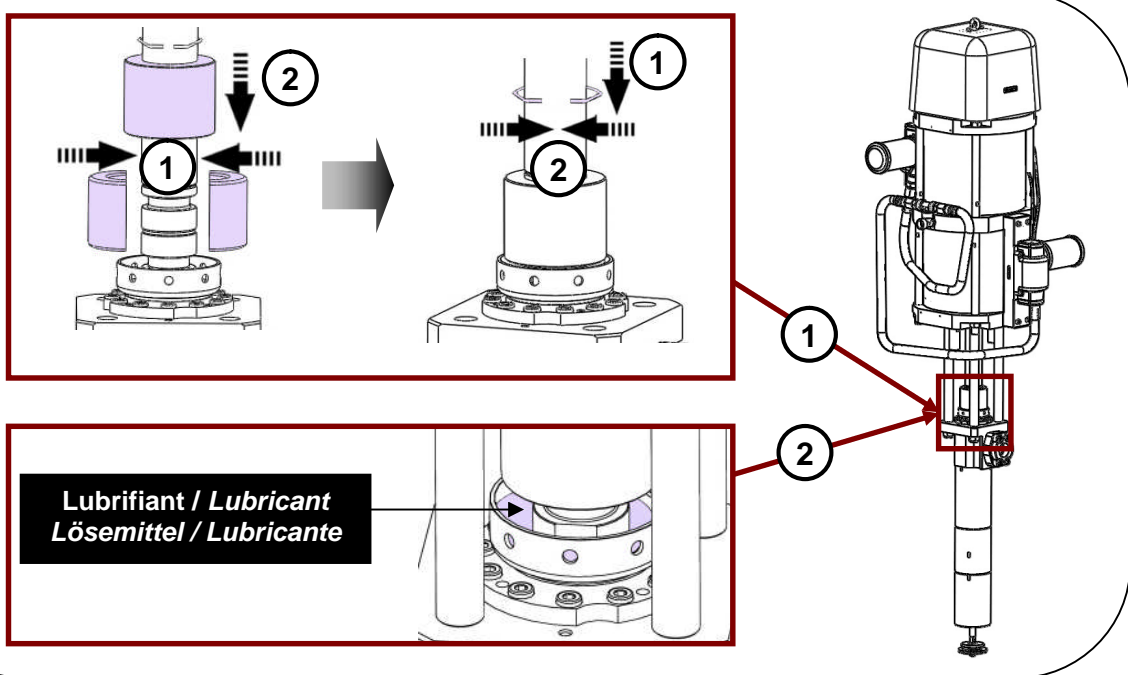



11

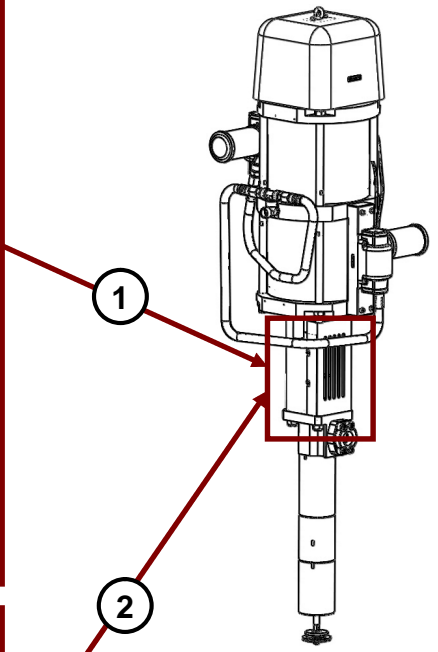
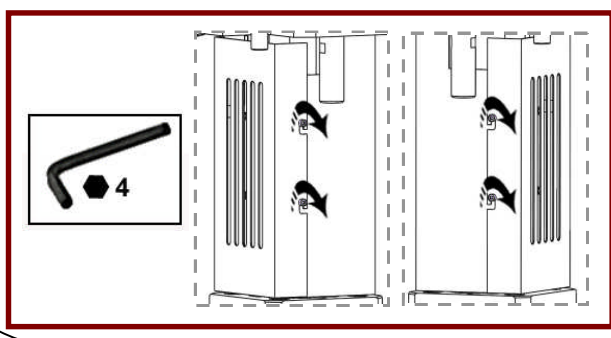
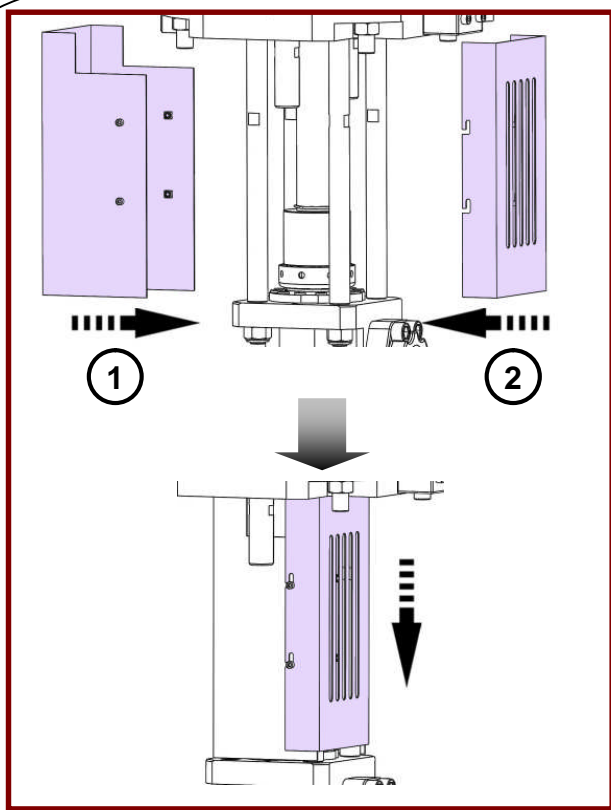

12

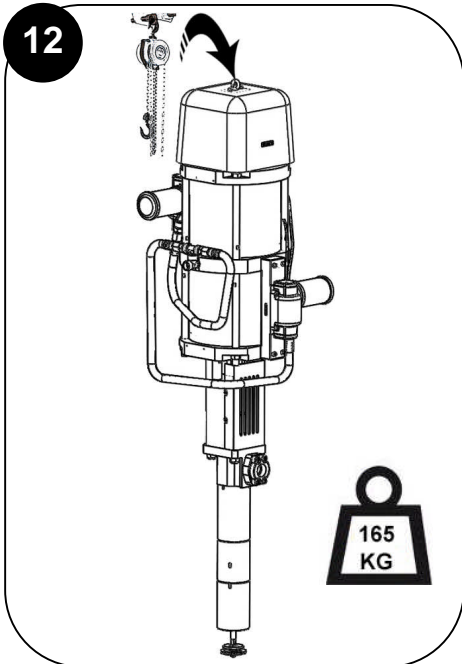

**DEMONTAGE / REMONTAGE  
DISASSEMBLY / REASSEMBLY  
DEMONTAGE / MONTAGE  
DESMONTAJE / MONTAJE**

**MOTEUR A AIR / AIR MOTOR  
LUFTMOTOR / MOTOR DE AIRE  
9200-2**

NOTICE ORIGINALE  
/ TRANSLATION OF THE ORIGINAL MANUAL  
/ ÜBERSETZUNG DER ORIGINAL BEDIENUNGSANLEITUNG  
/ TRADUCCIÓN DEL LIBRO ORIGINAL

**La pompe est soumise à la directive ATEX et ne doit en aucun cas être modifiée.  
Le non-respect de cette préconisation ne saurait engager notre responsabilité.  
/ The pump is manufactured under the ATEX agreement and can not be modified.  
KREMLIN REXSON will not be held responsible for any failure to comply with that instruction.**

**/ Diese Pumpe hat die ATEX Zulassung, deswegen darf sie nie verändert werden. Bei Nichtbeachtung dieser Anordnung, können wir keine Verantwortung für eine einwandfreie, regelkonforme Funktion der Pumpe übernehmen.**

**/ La bomba es de conformidad a la directiva ATEX y no debe ser modificada, en ningún caso. Kremlin Rexson no se hace responsable de que esta preconización no sea respetada.**

**Des protecteurs (capot moteur, protecteur d'accouplement, carters,...) sont mis en place pour une utilisation sûre du matériel.**

**Le fabricant ne peut être tenu pour responsable en cas de dommages corporels ainsi que des pannes et / ou endommagement du matériel résultant de la destruction, de l'occultation ou du retrait total ou partiel des protecteurs.**

**/ Guards (air motor cover, coupling shields, housings ...) have been designed for safe use of the equipment. The manufacturer will not be held responsible for bodily injury or failure and / or damage to property due to removal or partial removal of the guards.**

**/ Schutzvorrichtungen an diesem Gerät, wie Motorhaube, Kupplungsschutz, Gehäuse, ggf. Erdungskabel, sowie weitere Vorrichtungen, wurden für eine sichere Benutzung dieses Gerätes entwickelt und angebracht. Der Hersteller lehnt jede Verantwortung für Körperschäden, Fehlfunktionen, Beschädigung der Geräte und jegliche andere Fehler ab, die durch die ganze oder teilweise Entfernung, Modifikation oder unsachgemäße Handhabung der Schutzvorrichtungen oder anderer Geräteteile entstehen.**

**/ Protectores (capó motor, protector de acoplamiento, cárteres,...) se colocan para una utilización segura del material. El fabricante no se hace responsable, en caso de daños personales, así como de las averías y / o daños del material, resultantes de la destrucción, la ocultación o la retirada total o parcial de los protectores.**

***Vous aurez besoin de / you need / Werkzeugaufstellung / Vd necesita :***

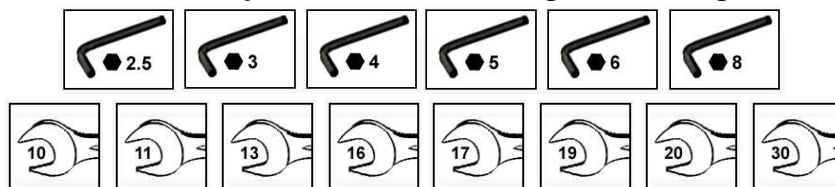

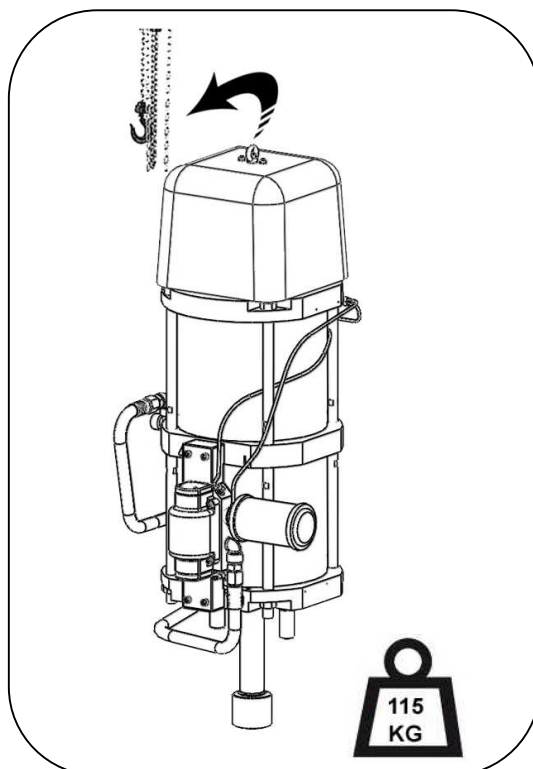
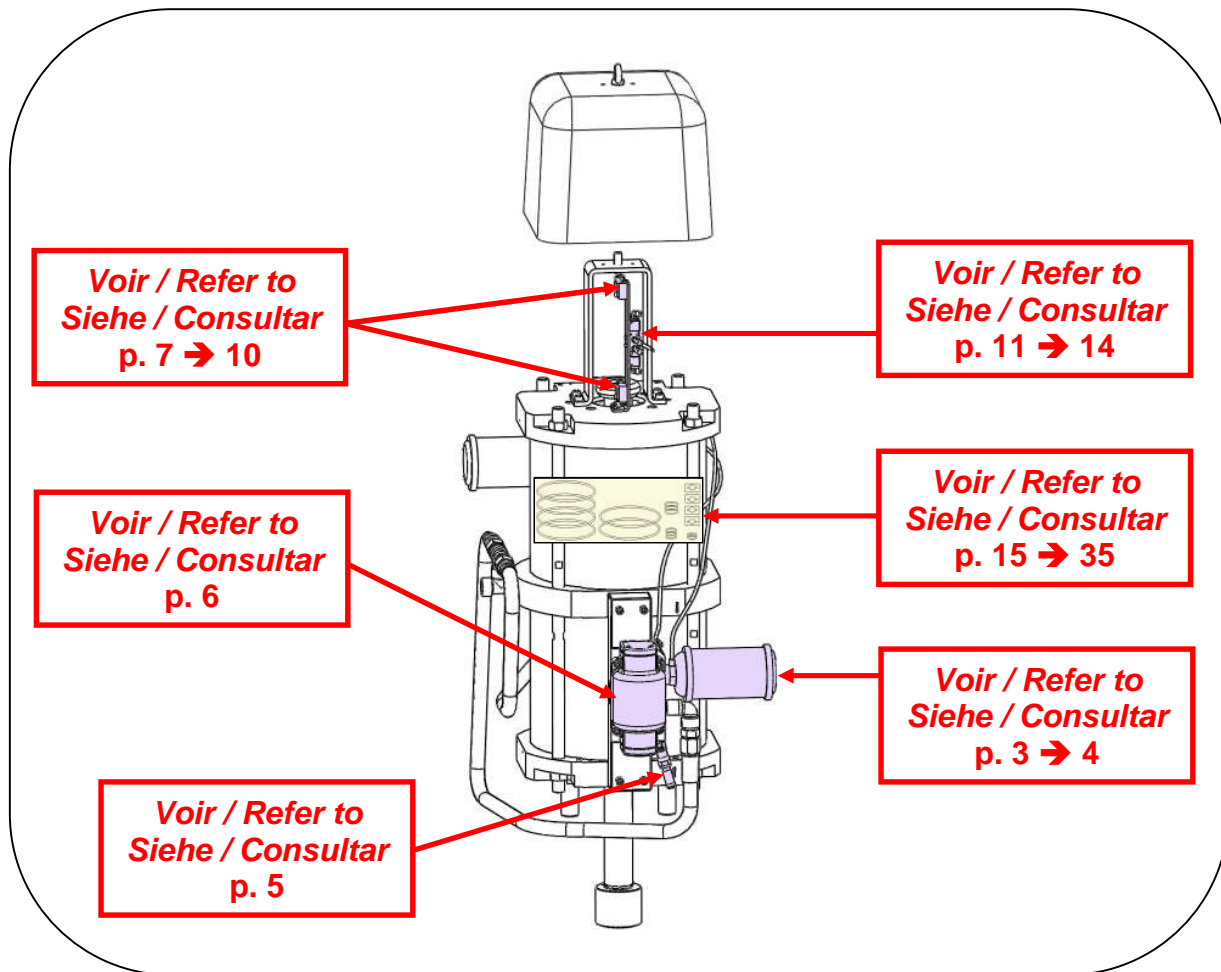

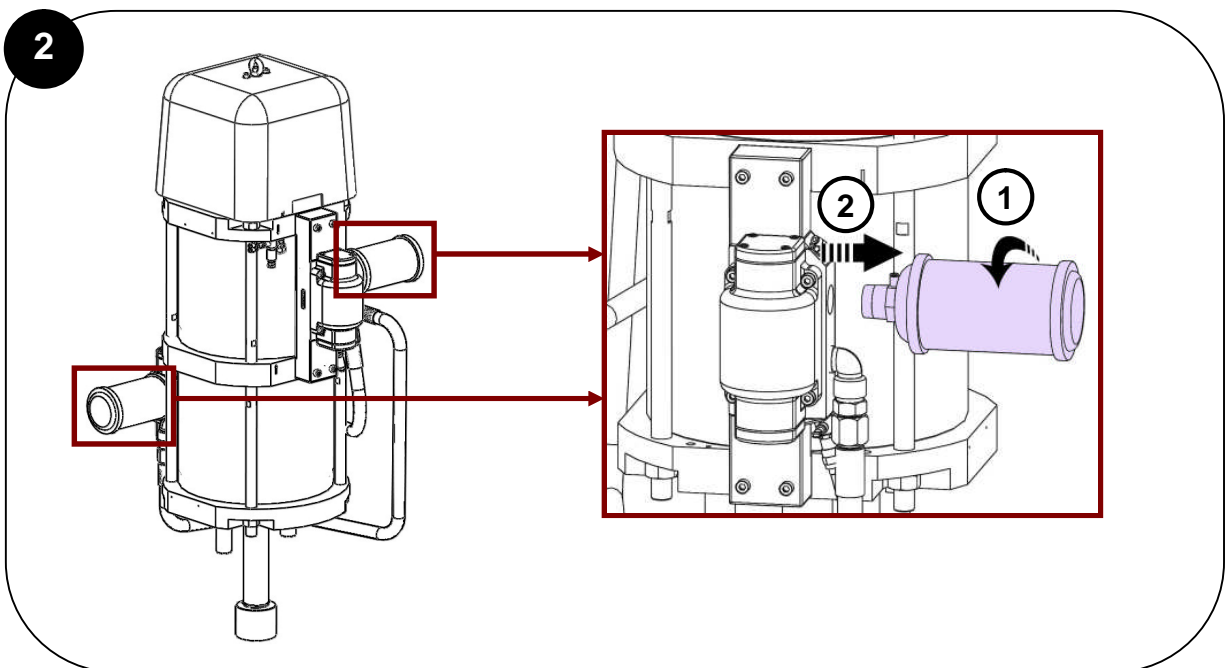
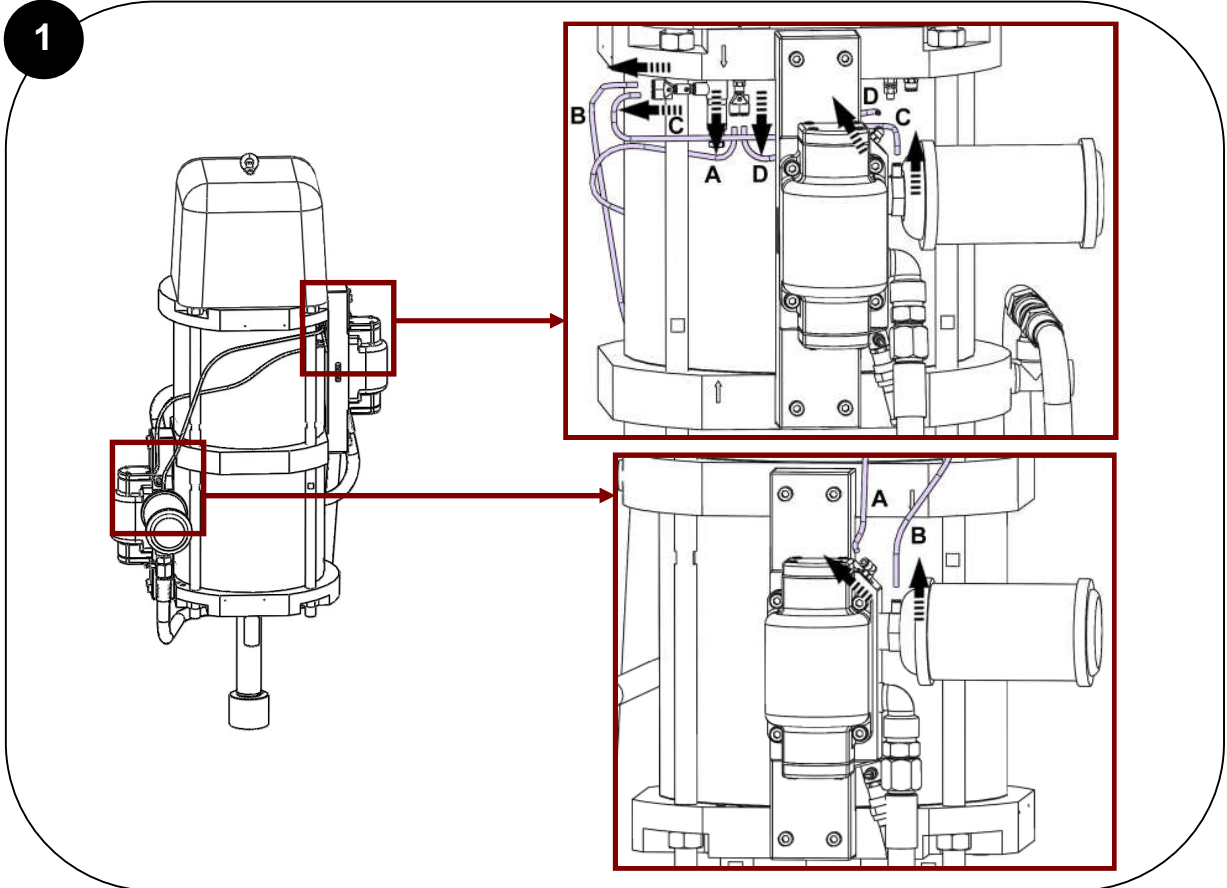
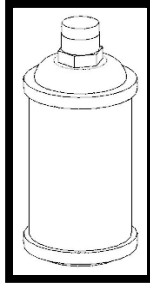

3

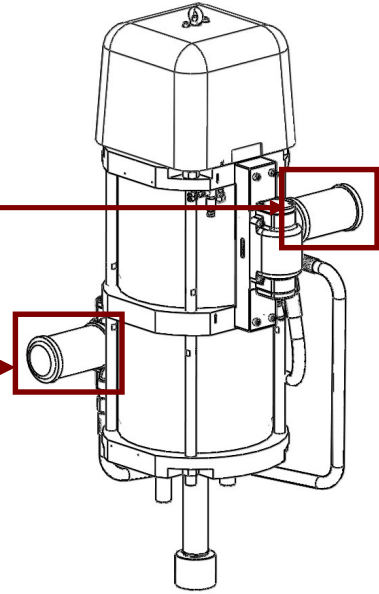
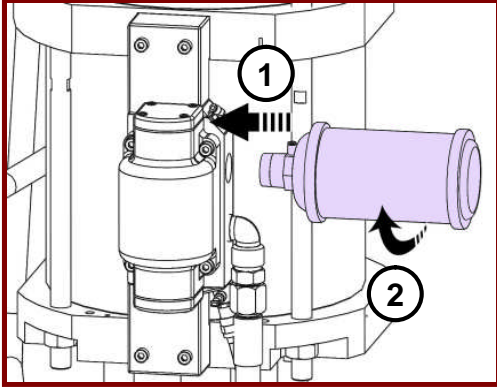

4

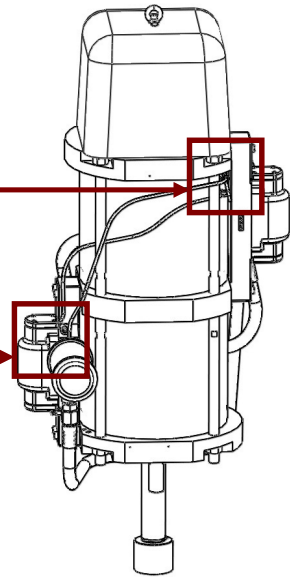
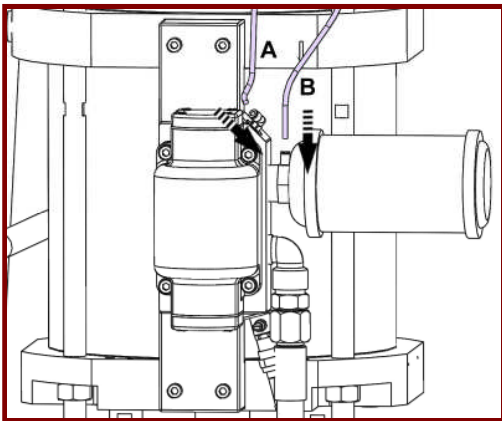
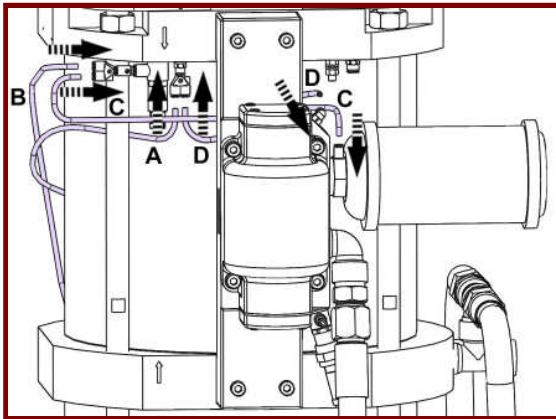

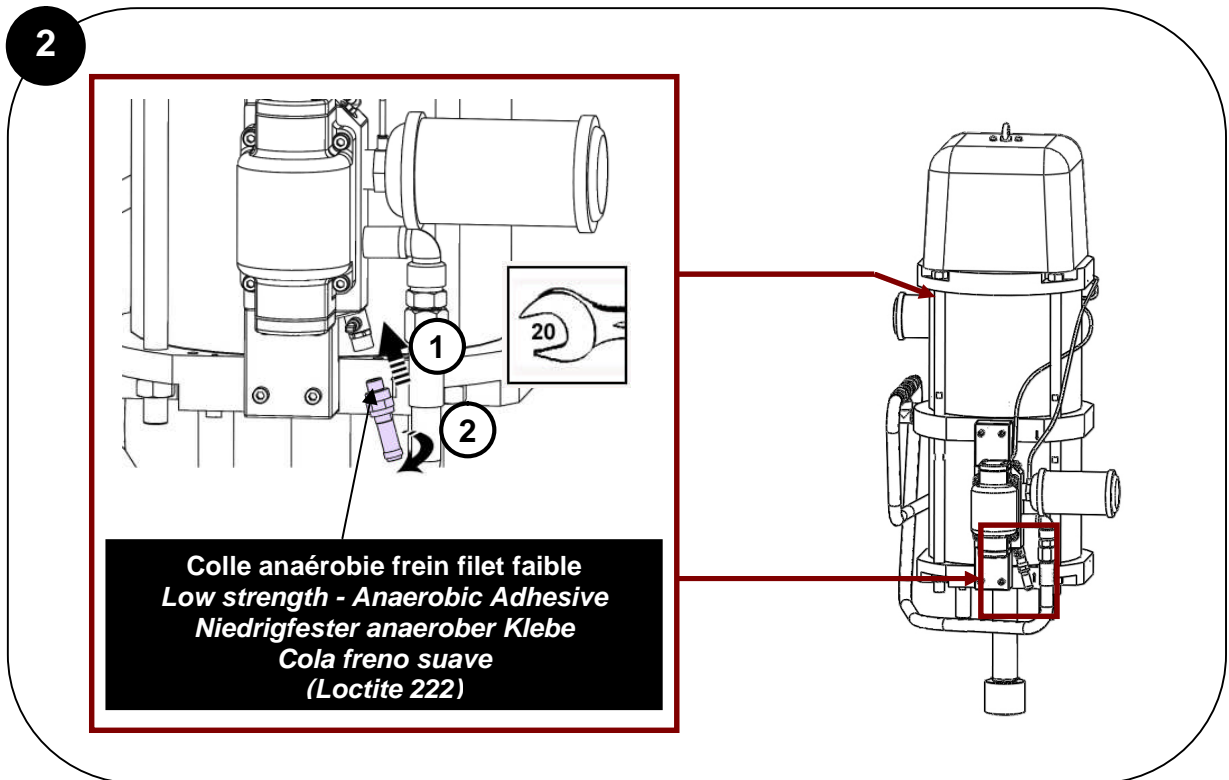
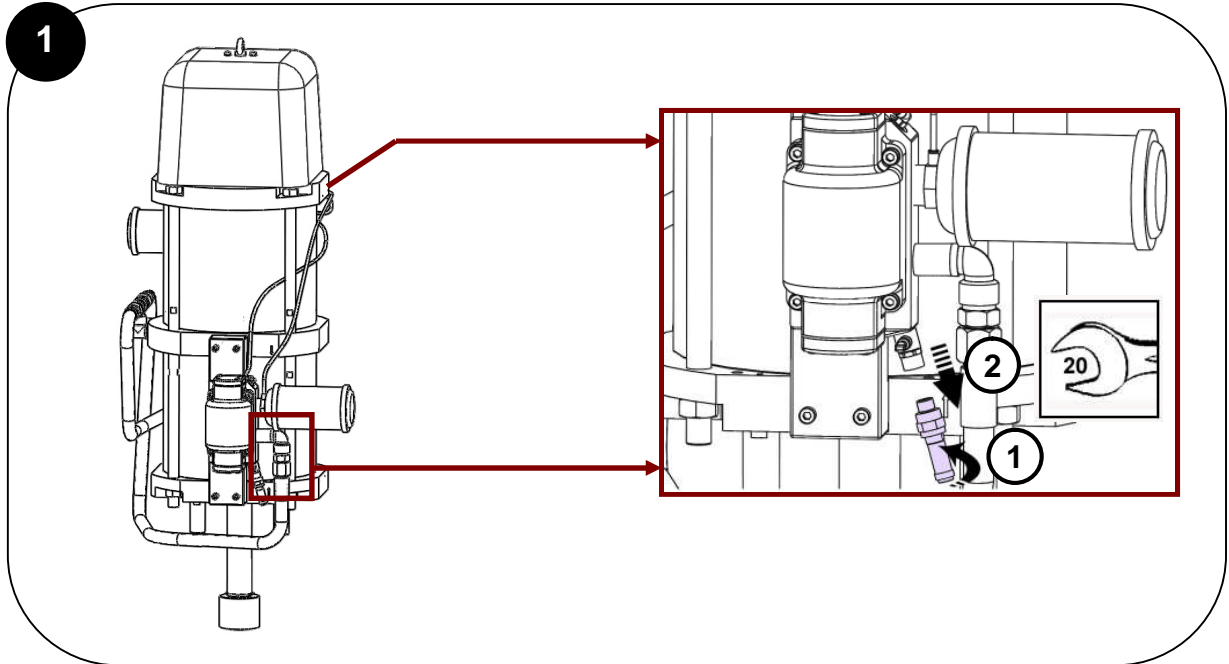
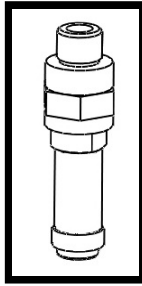

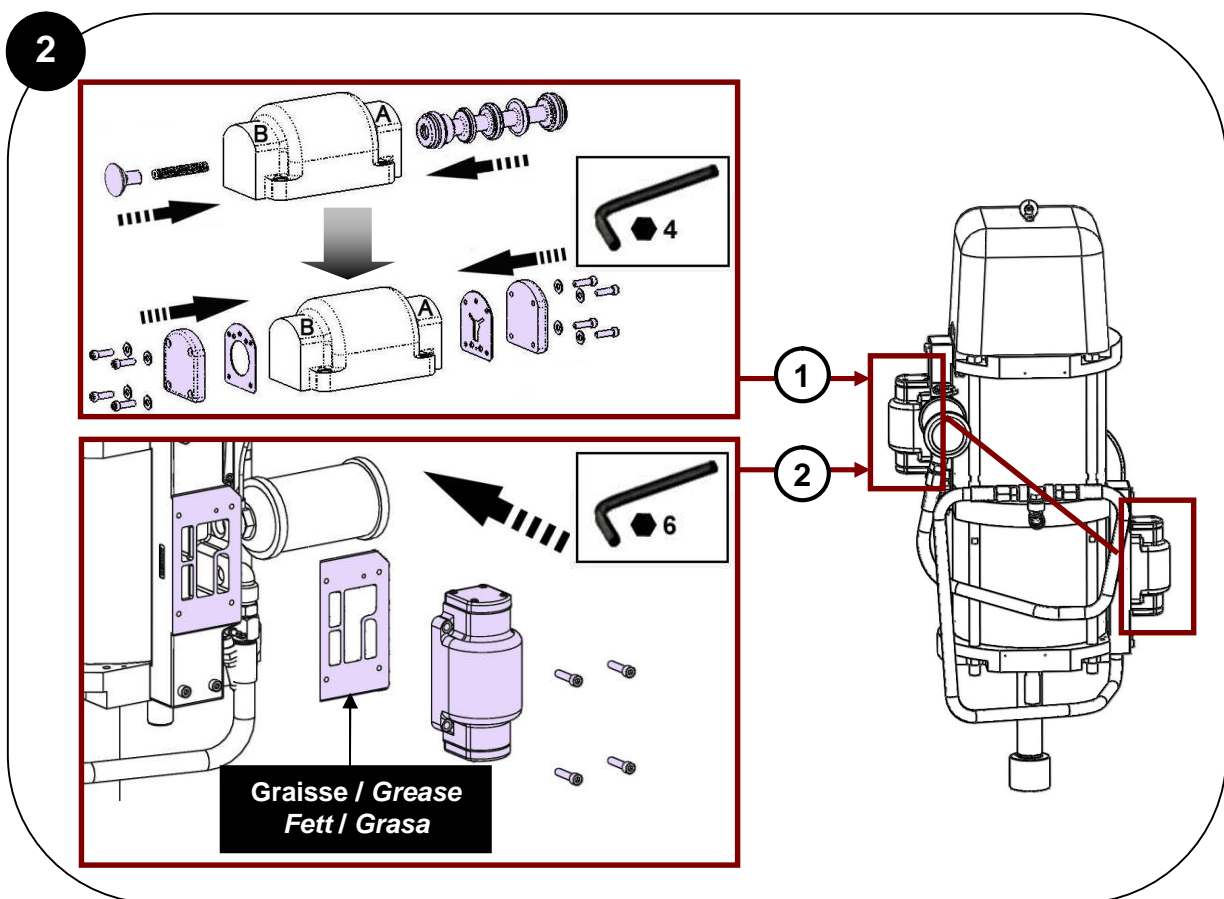
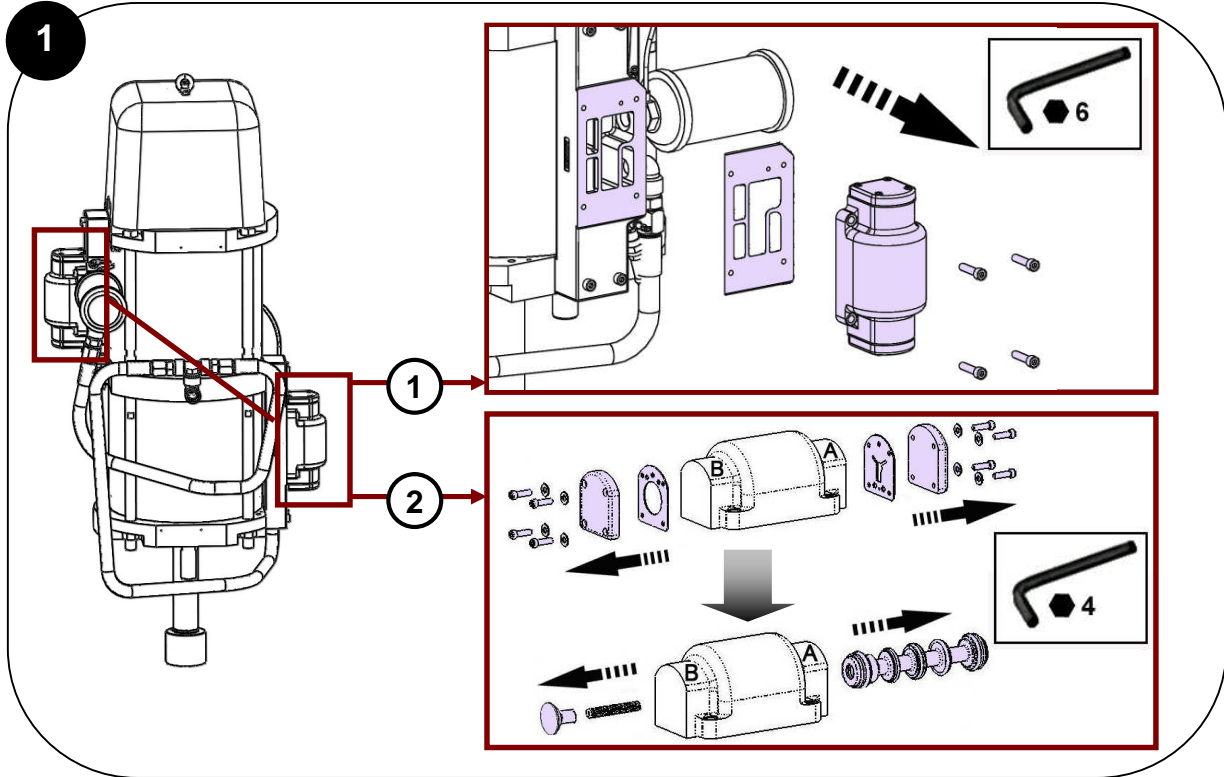
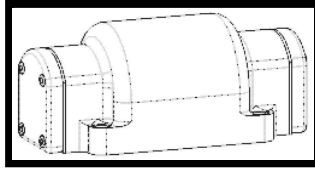

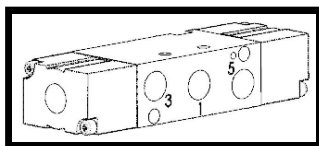

**Des protecteurs (capot moteur, protecteur d'accouplement, carters,...) sont mis en place pour une utilisation sûre du matériel.**

**Le fabricant ne peut être tenu pour responsable en cas de dommages corporels ainsi que des pannes et / ou endommagement du matériel résultant de la destruction, de l'occultation ou du retrait total ou partiel des protecteurs.**

**/ Guards (air motor cover, coupling shields, housings ...) have been designed for safe use of the equipment. The manufacturer will not be held responsible for bodily injury or failure and / or damage to property due to removal or partial removal of the guards.**

**/ Schutzvorrichtungen an diesem Gerät, wie Motorhaube, Kupplungsschutz, Gehäuse, ggf. Erdungskabel, sowie weitere Vorrichtungen, wurden für eine sichere Benutzung dieses Gerätes entwickelt und angebracht. Der Hersteller lehnt jede Verantwortung für Körperschäden, Fehlfunktionen, Beschädigung der Geräte und jegliche andere Fehler ab, die durch die ganze oder teilweise Entfernung, Modifikation oder unsachgemäße Handhabung der Schutzvorrichtungen oder anderer Geräteteile entstehen.**

**/ Protectores (capó motor, protector de acoplamiento, cárteres,...) se colocan para una utilización segura del material. El fabricante no se hace responsable, en caso de daños personales, así como de las averías y / o daños del material, resultantes de la destrucción, la ocultación o la retirada total o parcial de los protectores.**

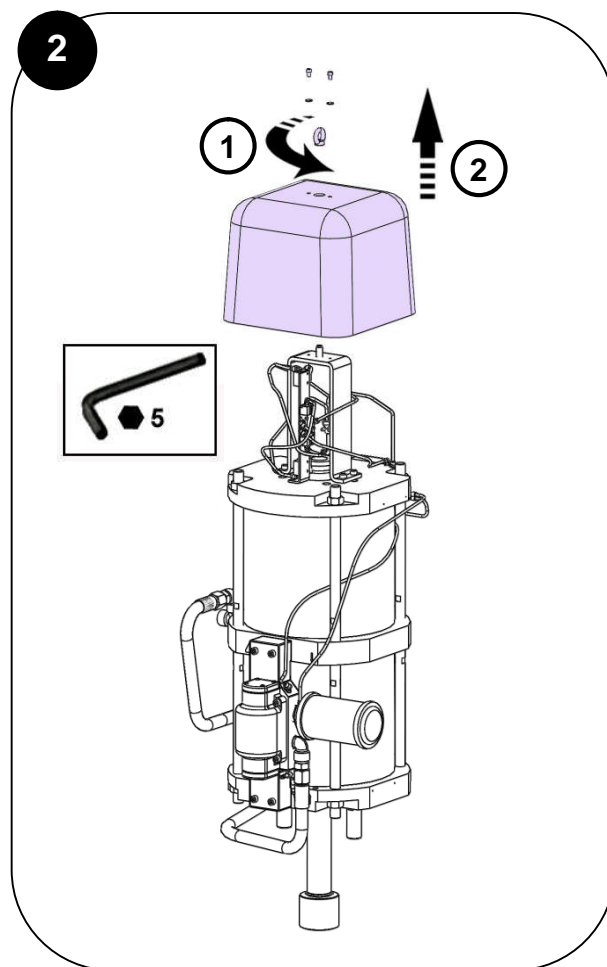
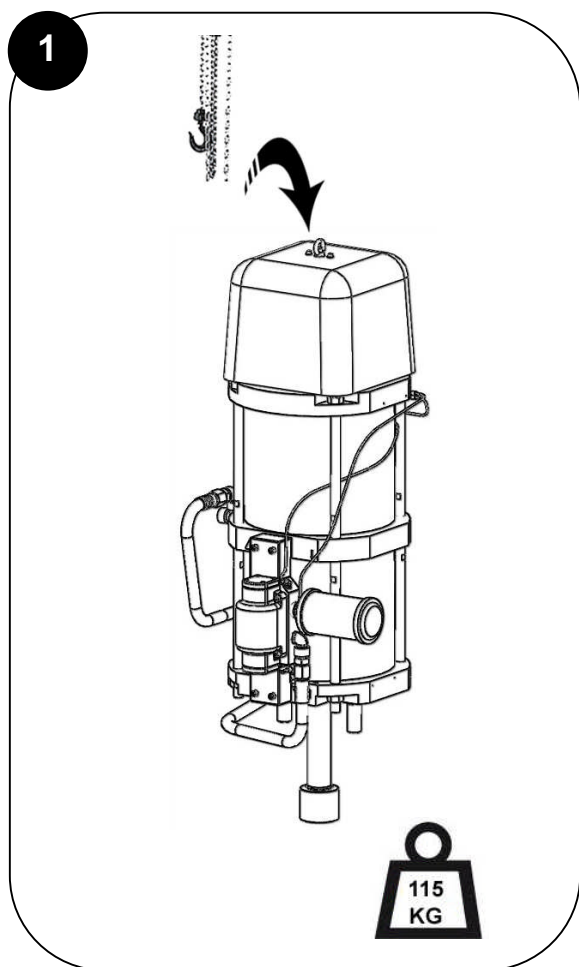



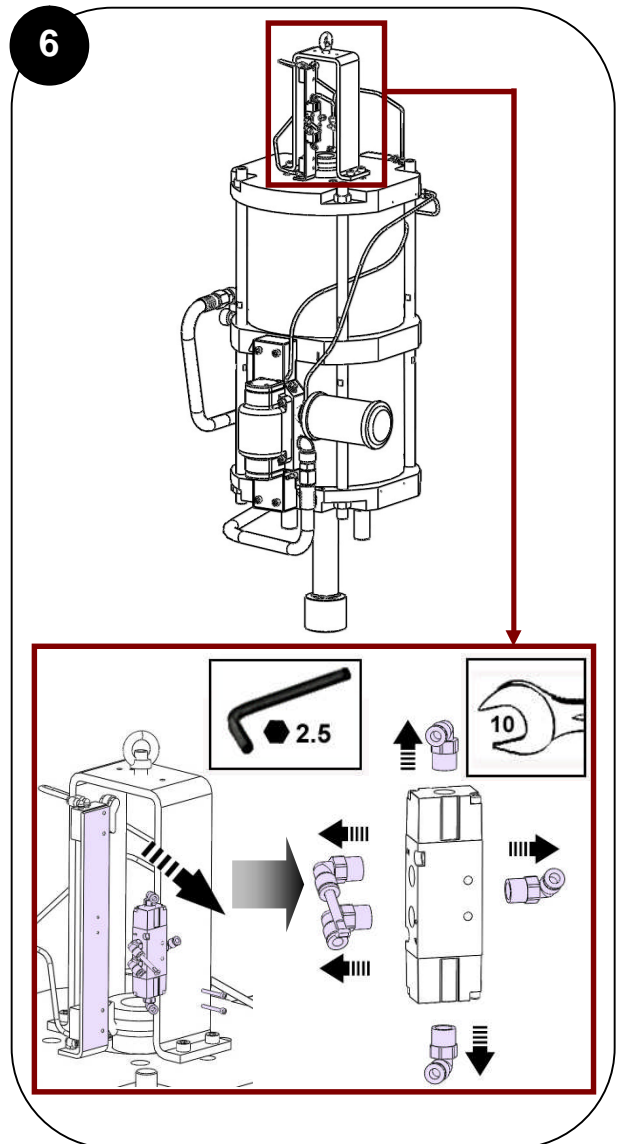
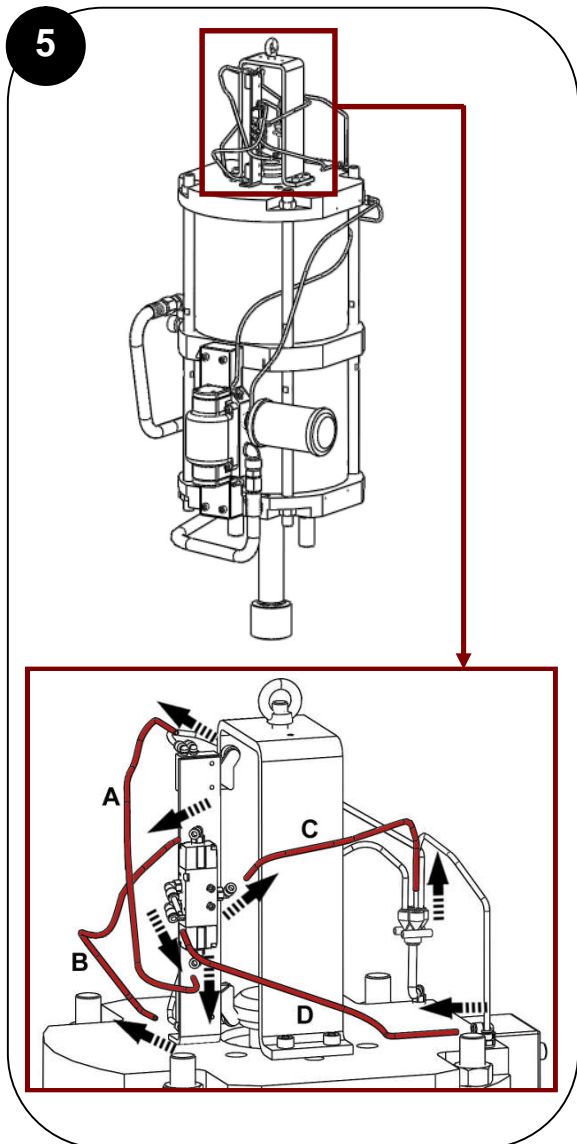
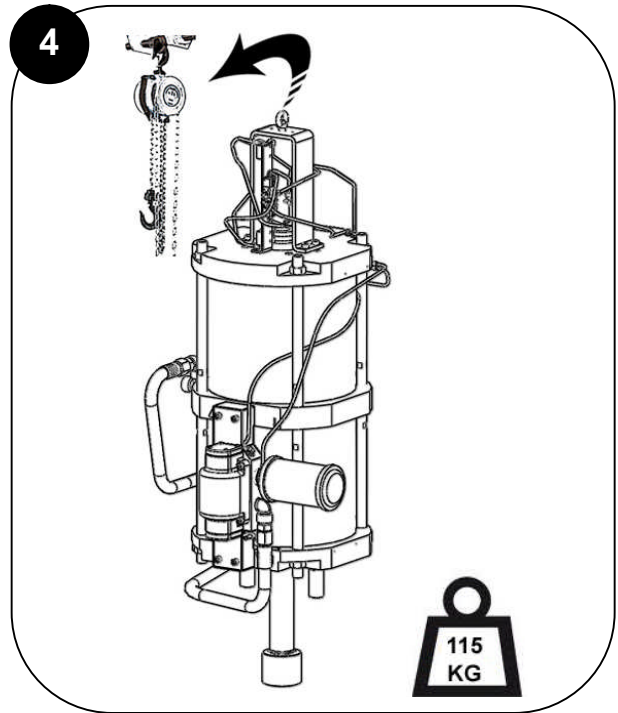
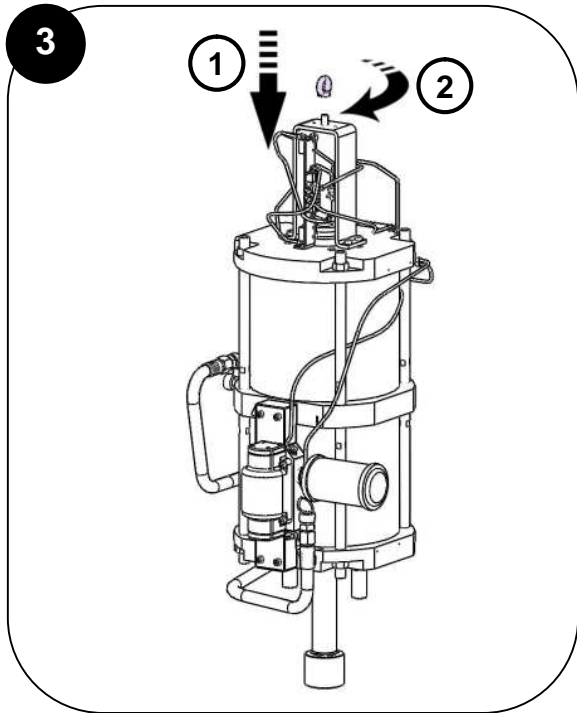

Des protecteurs (capot moteur, protecteur d'accouplement, carters,...) sont mis en place pour une utilisation sûre du matériel.

Le fabricant ne peut être tenu pour responsable en cas de dommages corporels ainsi que des pannes et / ou endommagement du matériel résultant de la destruction, de l'occultation ou du retrait total ou partiel des protecteurs.

/ Guards (air motor cover, coupling shields, housings ...) have been designed for safe use of the equipment. The manufacturer will not be held responsible for bodily injury or failure and / or damage to property due to removal or partial removal of the guards.

/ Schutzvorrichtungen an diesem Gerät, wie Motorhaube, Kupplungsschutz, Gehäuse, ggf. Erdungskabel, sowie weitere Vorrichtungen, wurden für eine sichere Benutzung dieses Gerätes entwickelt und angebracht. Der Hersteller lehnt jede Verantwortung für Körperschäden, Fehlfunktionen, Beschädigung der Geräte und jegliche andere Fehler ab, die durch die ganze oder teilweise Entfernung, Modifikation oder unsachgemäße Handhabung der Schutzvorrichtungen oder anderer Geräteteile entstehen.

/ Protectores (capó motor, protector de acoplamiento, cárteres,...) se colocan para una utilización segura del material. El fabricante no se hace responsable, en caso de daños personales, así como de las averías y / o daños del material, resultantes de la destrucción, la ocultación o la retirada total o parcial de los protectores.

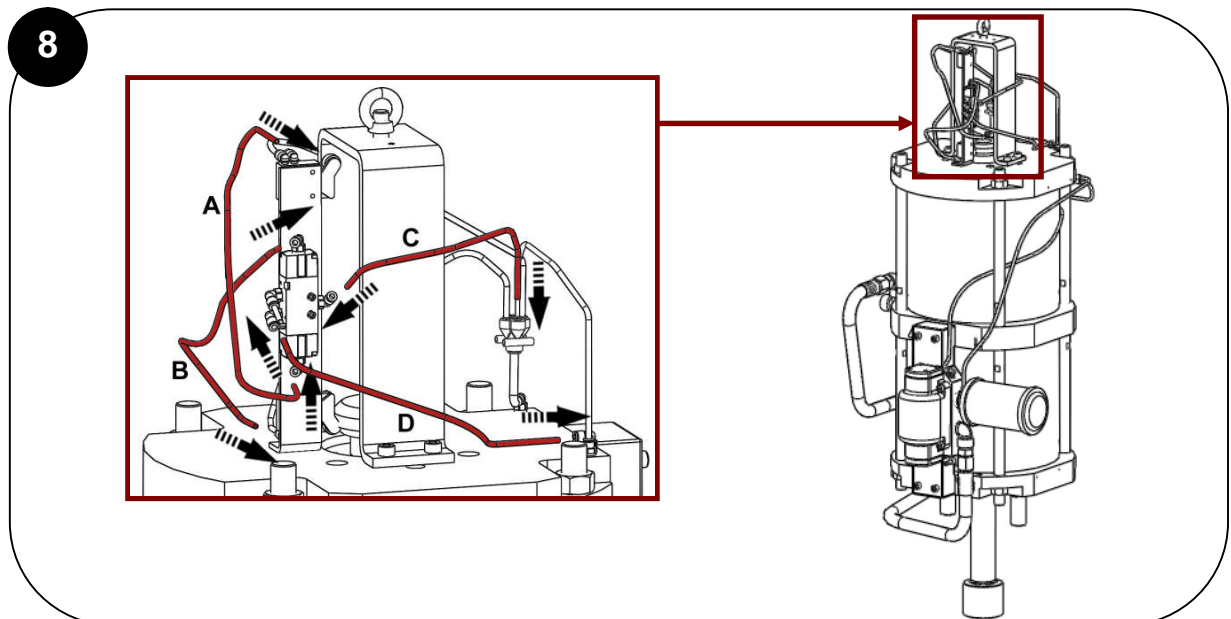
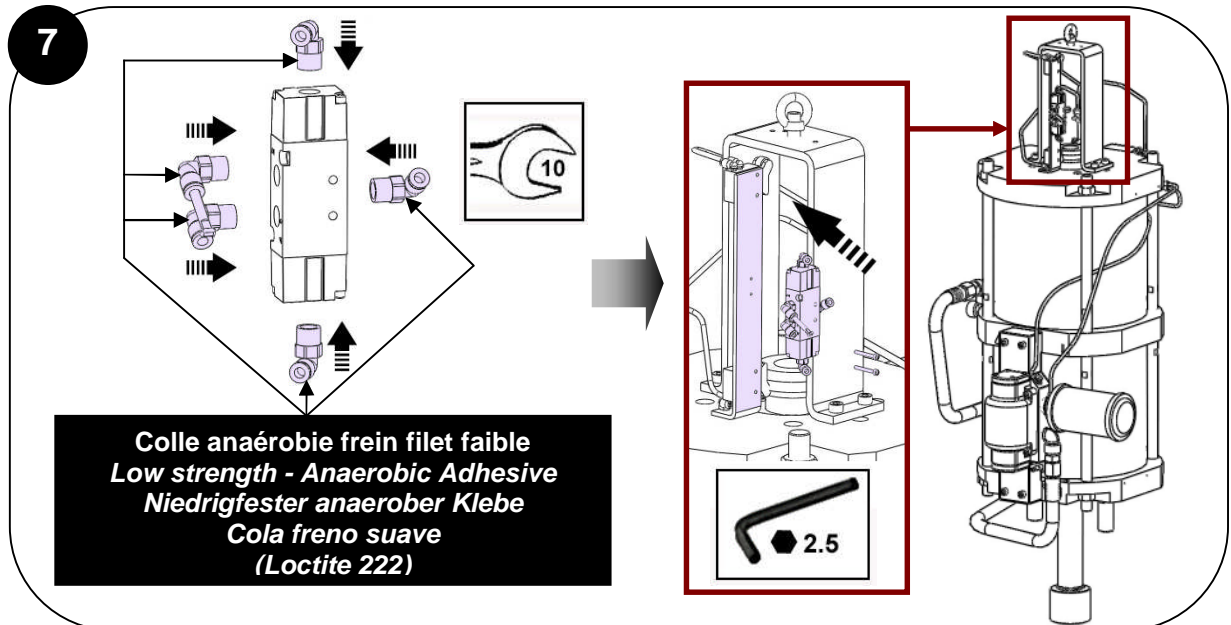

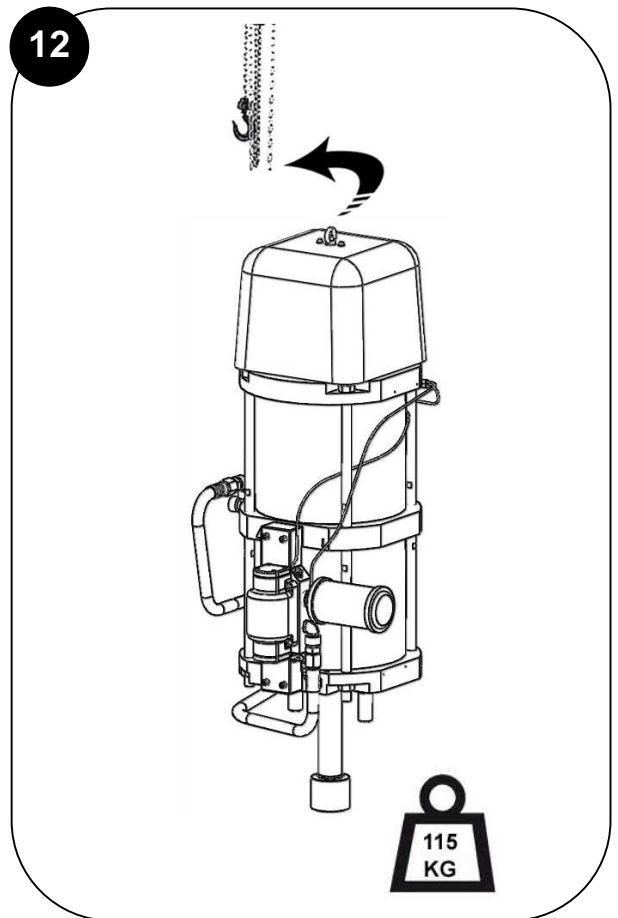
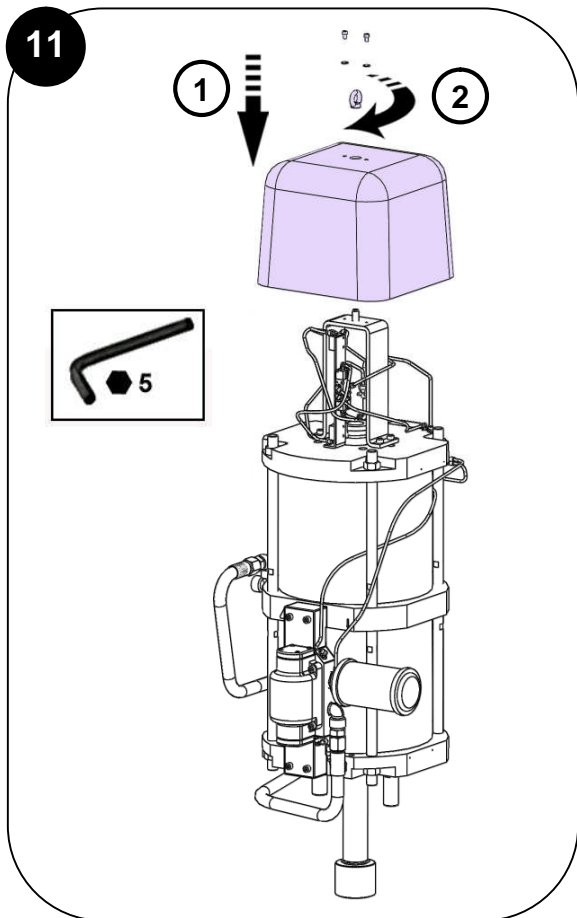
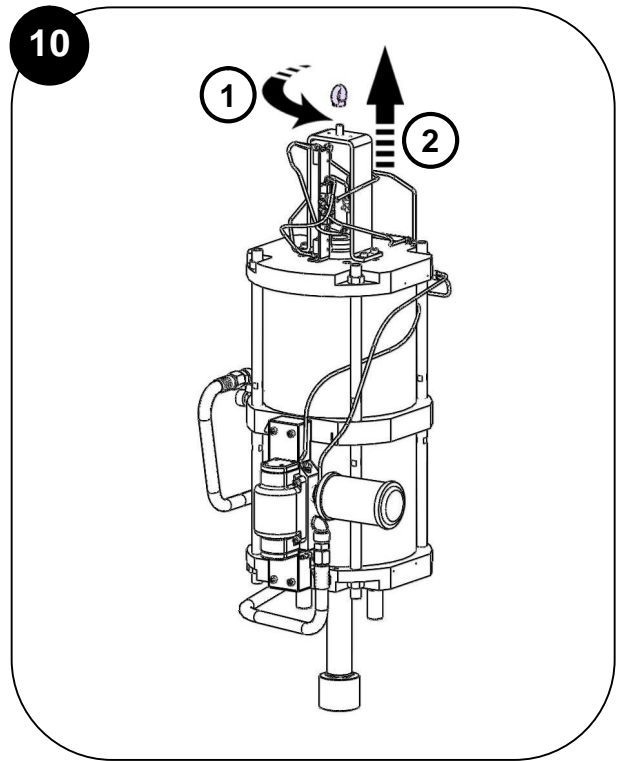
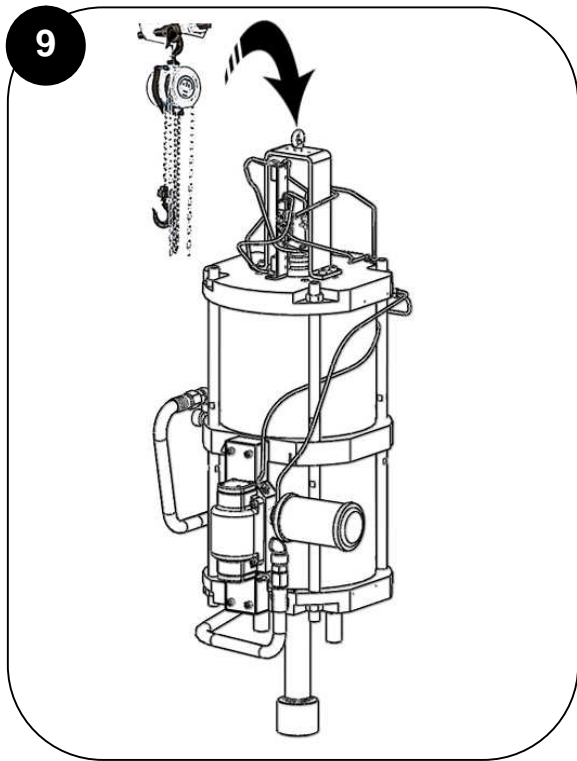

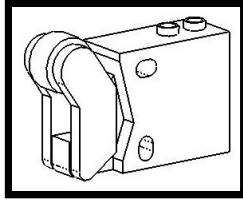

Des protecteurs (capot moteur, protecteur d'accouplement, carter,...) sont mis en place pour une utilisation sûre du matériel.

Le fabricant ne peut être tenu pour responsable en cas de dommages corporels ainsi que des pannes et / ou endommagement du matériel résultant de la destruction, de l'occultation ou du retrait total ou partiel des protecteurs.

/ Guards (air motor cover, coupling shields, housings ...) have been designed for safe use of the equipment. The manufacturer will not be held responsible for bodily injury or failure and / or damage to property due to removal or partial removal of the guards.

/ Schutzvorrichtungen an diesem Gerät, wie Motorhaube, Kupplungsschutz, Gehäuse, ggf. Erdungskabel, sowie weitere Vorrichtungen, wurden für eine sichere Benutzung dieses Gerätes entwickelt und angebracht. Der Hersteller lehnt jede Verantwortung für Körperschäden, Fehlfunktionen, Beschädigung der Geräte und jegliche andere Fehler ab, die durch die ganze oder teilweise Entfernung, Modifikation oder unsachgemäße Handhabung der Schutzvorrichtungen oder anderer Geräteteile entstehen.

/ Protectores (capó motor, protector de acoplamiento, cárteres,...) se colocan para una utilización segura del material. El fabricante no se hace responsable, en caso de daños personales, así como de las averías y / o daños del material, resultantes de la destrucción, la ocultación o la retirada total o parcial de los protectores.

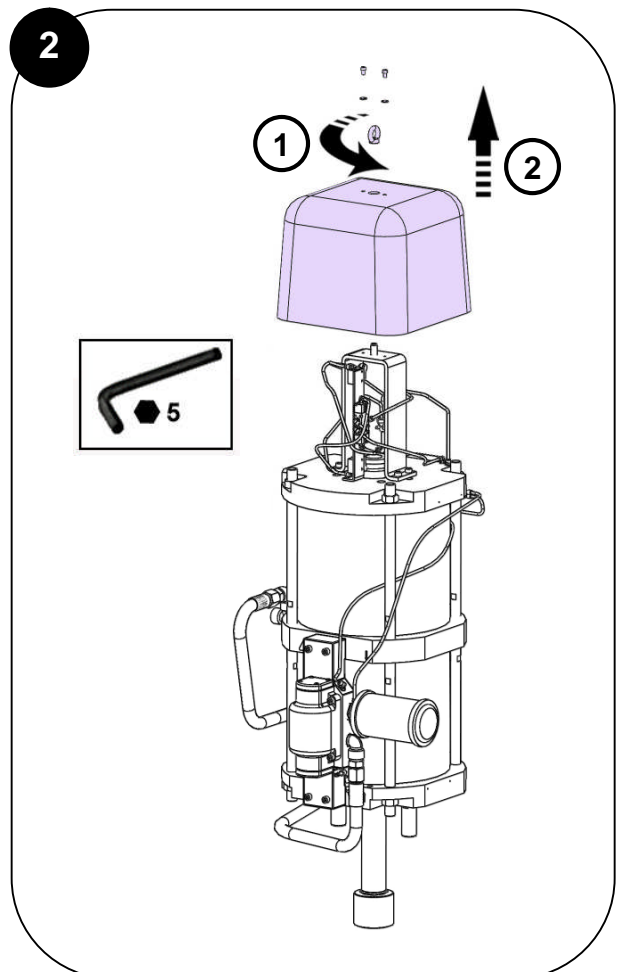
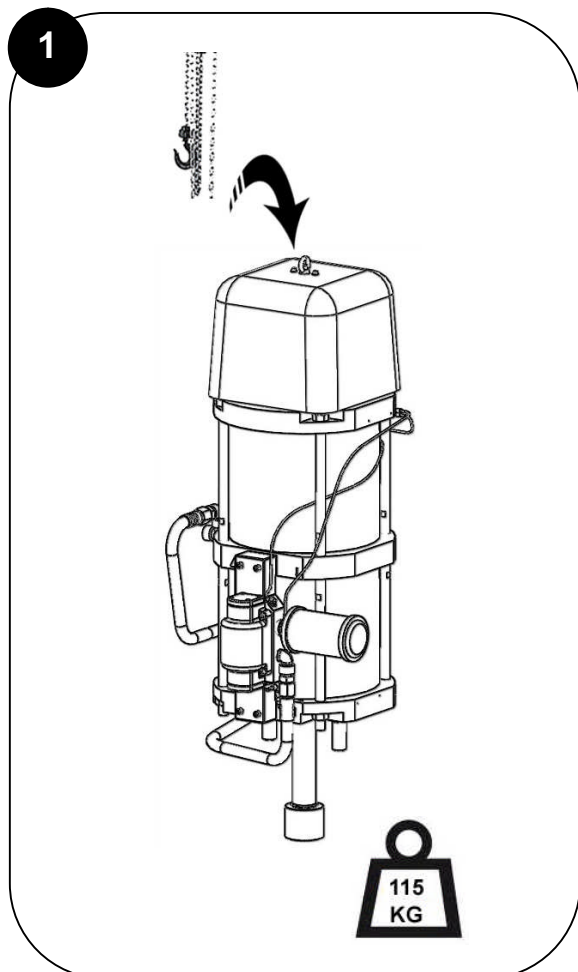

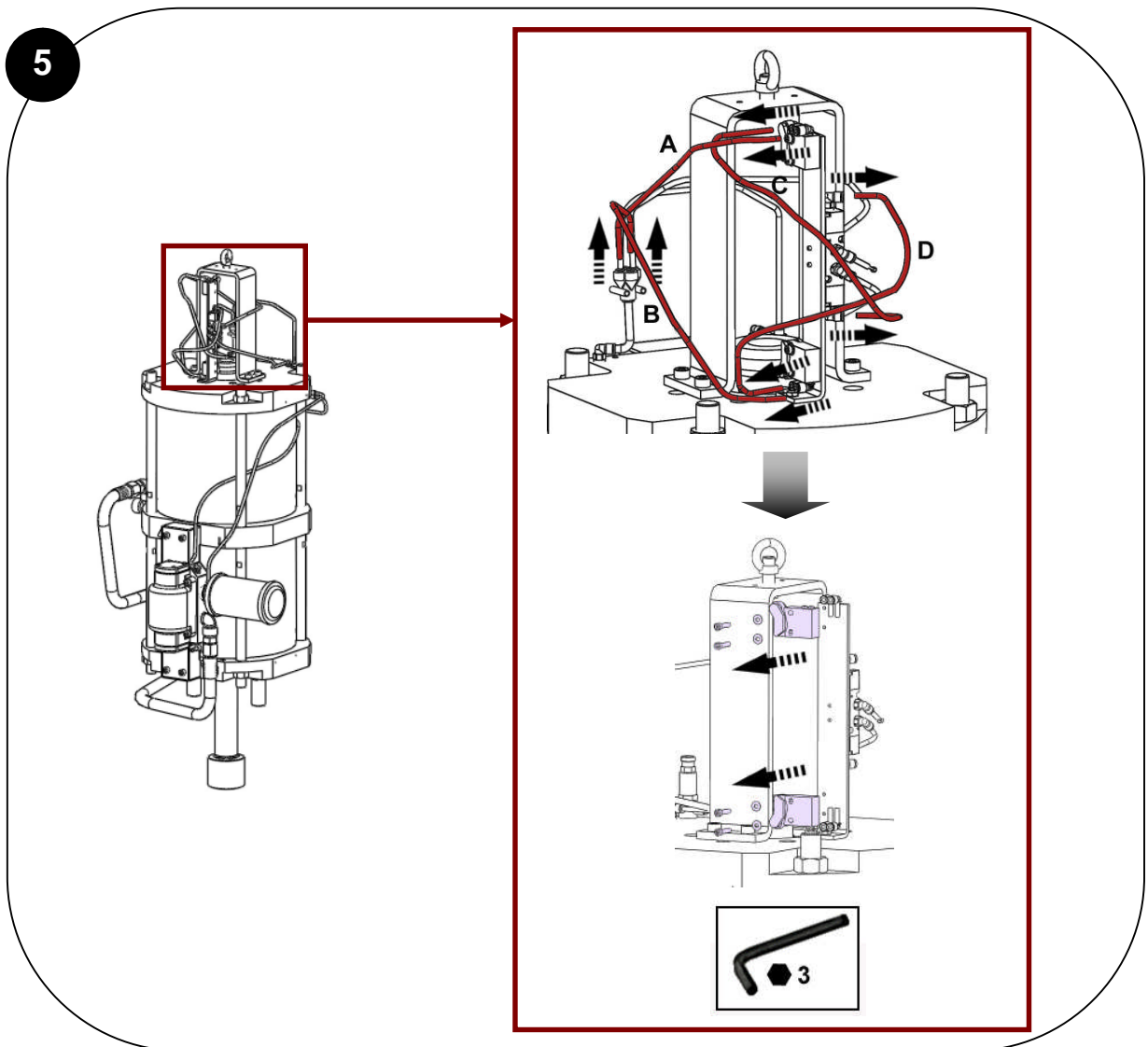
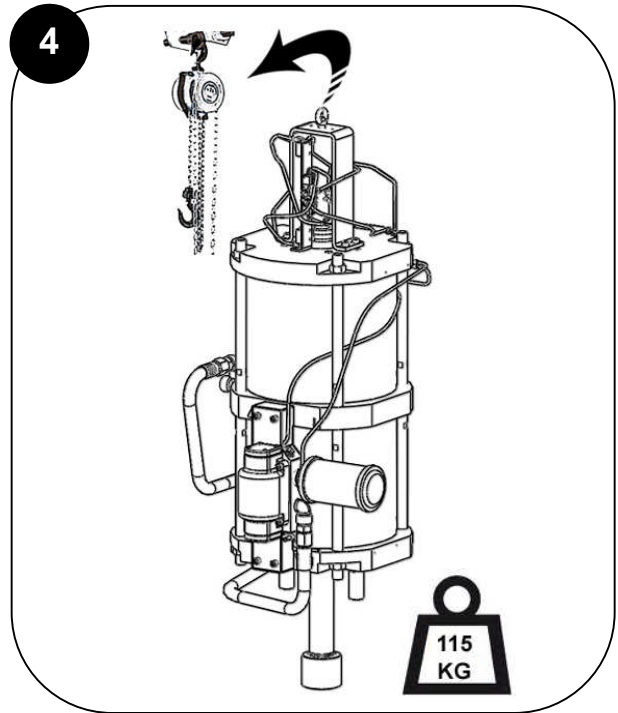
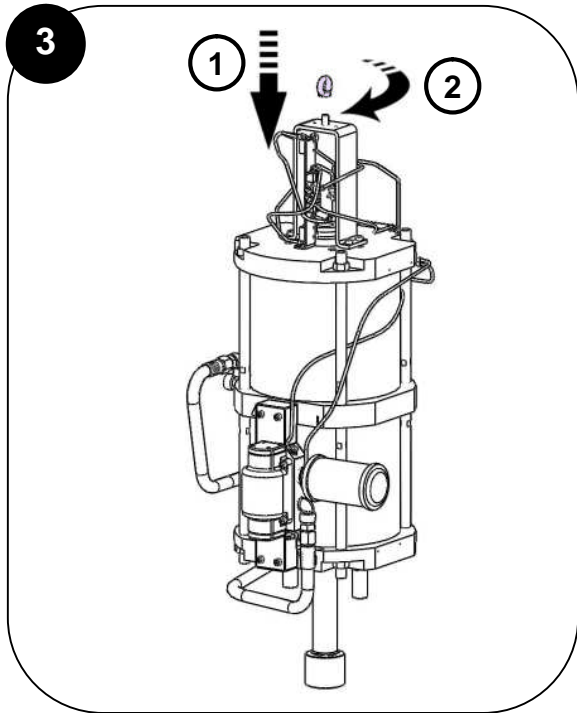

Des protecteurs (capot moteur, protecteur d'accouplement, carters,...) sont mis en place pour une utilisation sûre du matériel.

Le fabricant ne peut être tenu pour responsable en cas de dommages corporels ainsi que des pannes et / ou endommagement du matériel résultant de la destruction, de l'occultation ou du retrait total ou partiel des protecteurs.

/ Guards (air motor cover, coupling shields, housings ...) have been designed for safe use of the equipment. The manufacturer will not be held responsible for bodily injury or failure and / or damage to property due to removal or partial removal of the guards.

/ Schutzvorrichtungen an diesem Gerät, wie Motorhaube, Kupplungsschutz, Gehäuse, ggf. Erdungskabel, sowie weitere Vorrichtungen, wurden für eine sichere Benutzung dieses Gerätes entwickelt und angebracht. Der Hersteller lehnt jede Verantwortung für Körperschäden, Fehlfunktionen, Beschädigung der Geräte und jegliche andere Fehler ab, die durch die ganze oder teilweise Entfernung, Modifikation oder unsachgemäße Handhabung der Schutzvorrichtungen oder anderer Geräteteile entstehen.

/ Protectores (capó motor, protector de acoplamiento, cárteres,...) se colocan para una utilización segura del material. El fabricante no se hace responsable, en caso de daños personales, así como de las averías y / o daños del material, resultantes de la destrucción, la ocultación o la retirada total o parcial de los protectores.

6

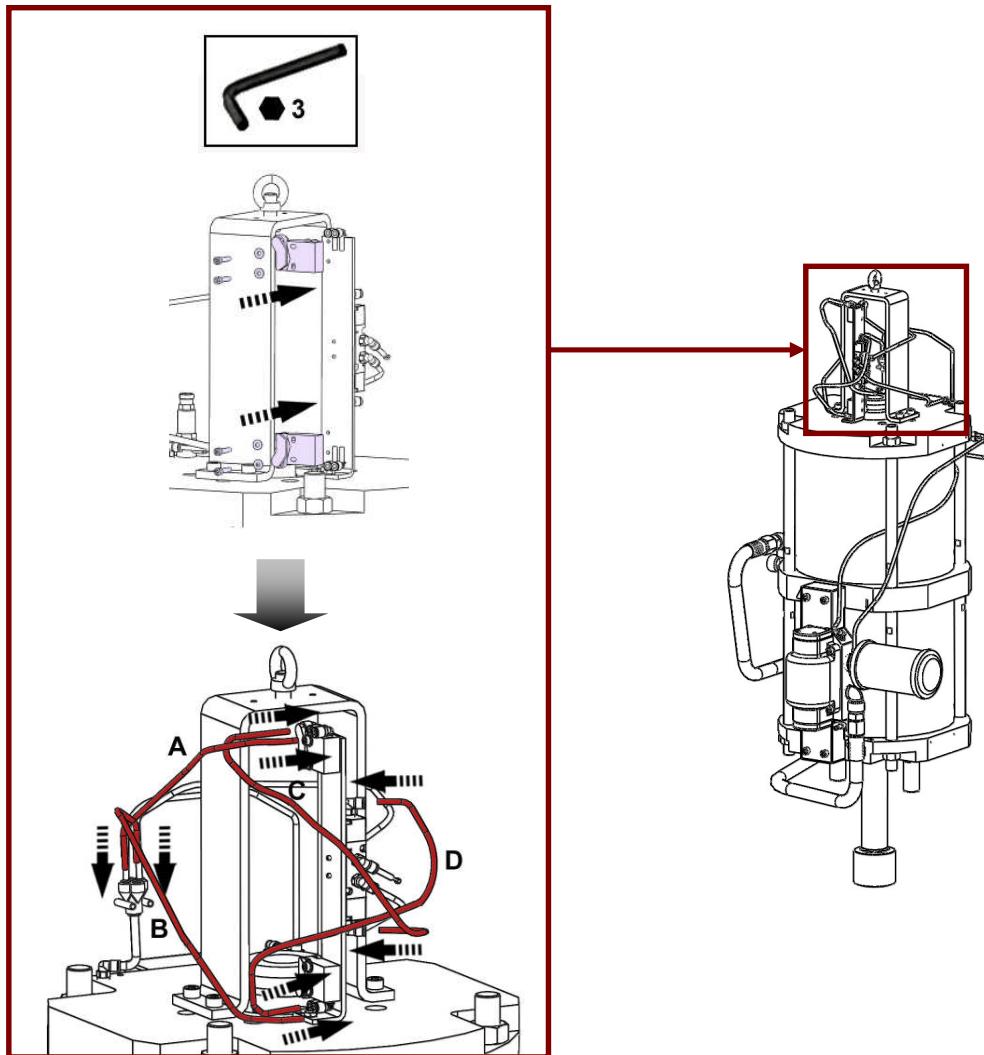

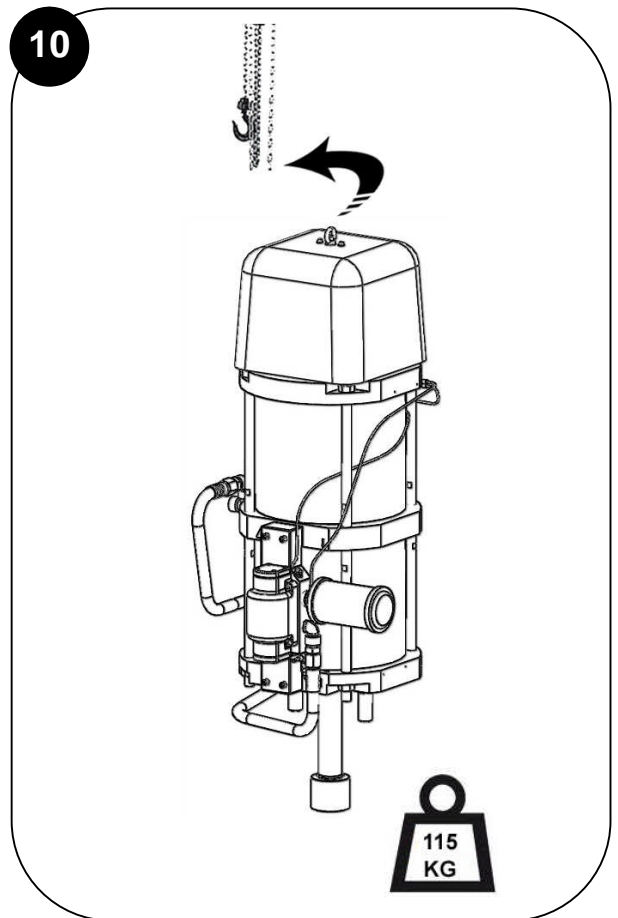
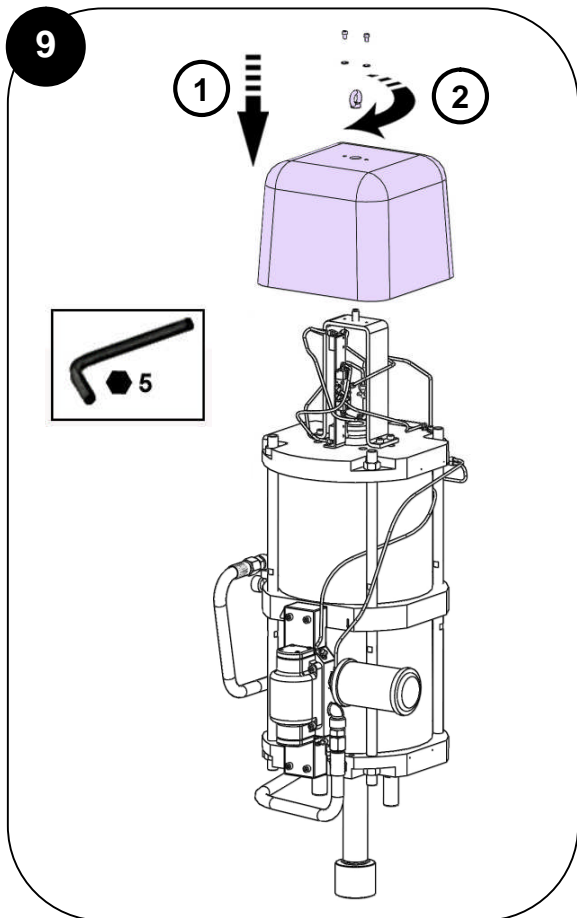
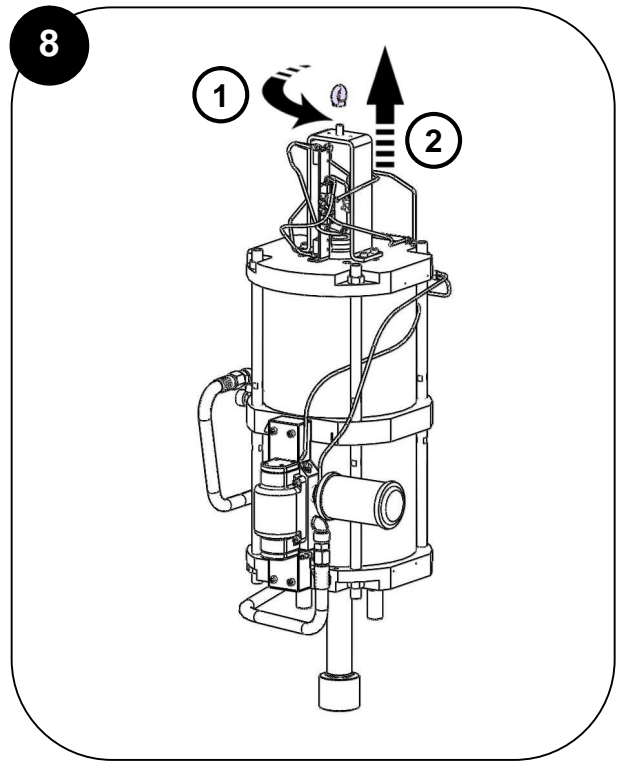
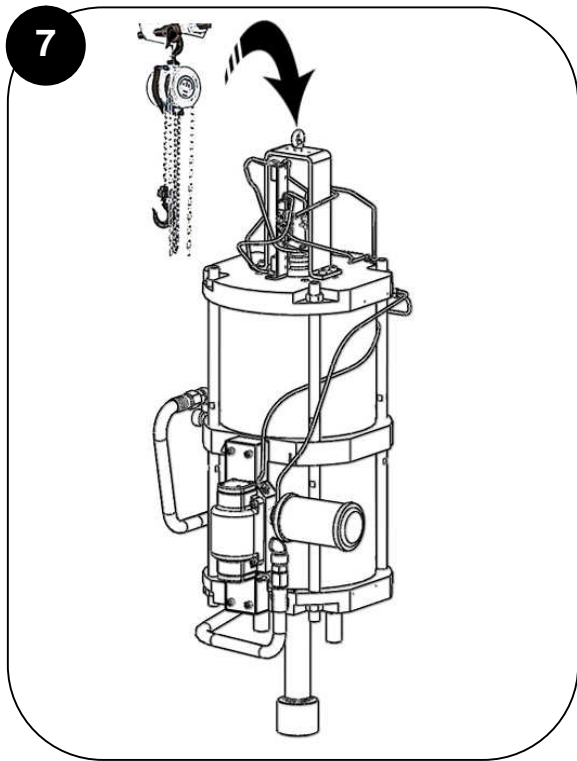

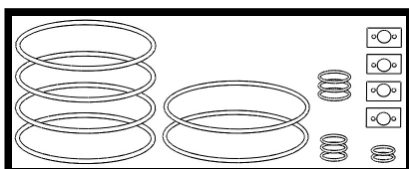

Des protecteurs (capot moteur, protecteur d'accouplement, carters,...) sont mis en place pour une utilisation sûre du matériel.

Le fabricant ne peut être tenu pour responsable en cas de dommages corporels ainsi que des pannes et / ou endommagement du matériel résultant de la destruction, de l'occultation ou du retrait total ou partiel des protecteurs.

*/ Guards (air motor cover, coupling shields, housings ...) have been designed for safe use of the equipment. The manufacturer will not be held responsible for bodily injury or failure and / or damage to property due to removal or partial removal of the guards.*

*/ Schutzvorrichtungen an diesem Gerät, wie Motorhaube, Kupplungsschutz, Gehäuse, ggf. Erdungskabel, sowie weitere Vorrichtungen, wurden für eine sichere Benutzung dieses Gerätes entwickelt und angebracht. Der Hersteller lehnt jede Verantwortung für Körperschäden, Fehlfunktionen, Beschädigung der Geräte und jegliche andere Fehler ab, die durch die ganze oder teilweise Entfernung, Modifikation oder unsachgemäße Handhabung der Schutzvorrichtungen oder anderer Geräteteile entstehen.*

*/ Protectores (capó motor, protector de acoplamiento, cárteres,...) se colocan para una utilización segura del material. El fabricante no se hace responsable, en caso de daños personales, así como de las averías y / o daños del material, resultantes de la destrucción, la ocultación o la retirada total o parcial de los protectores.*

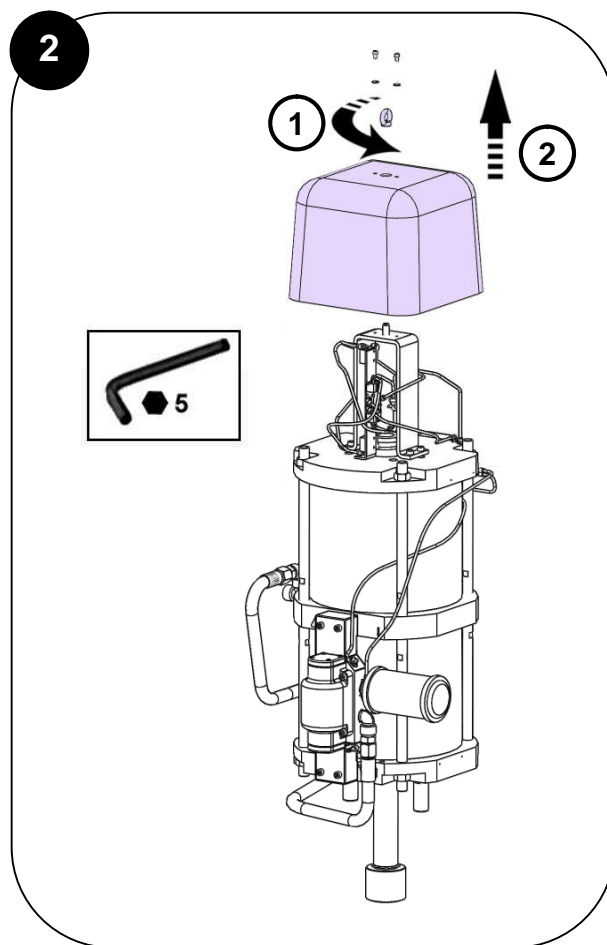
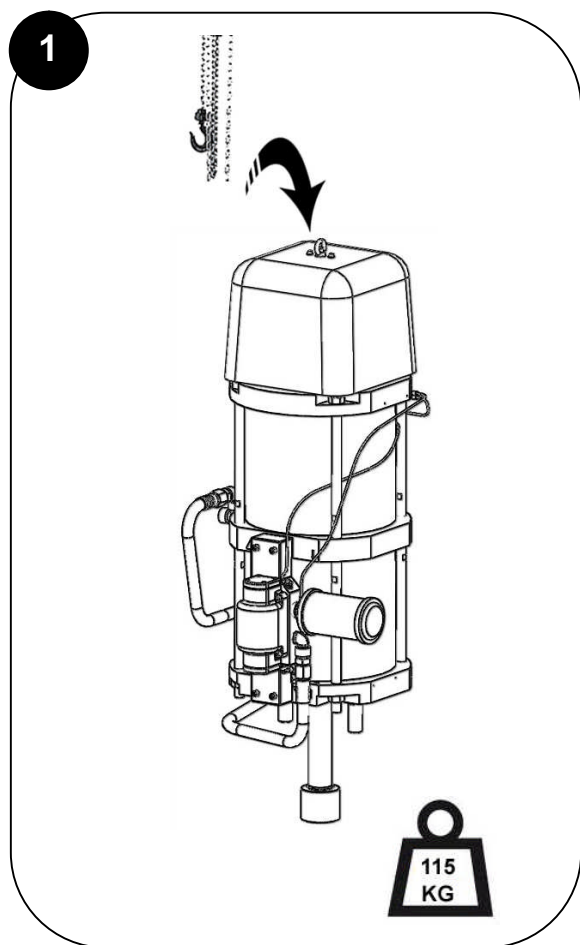



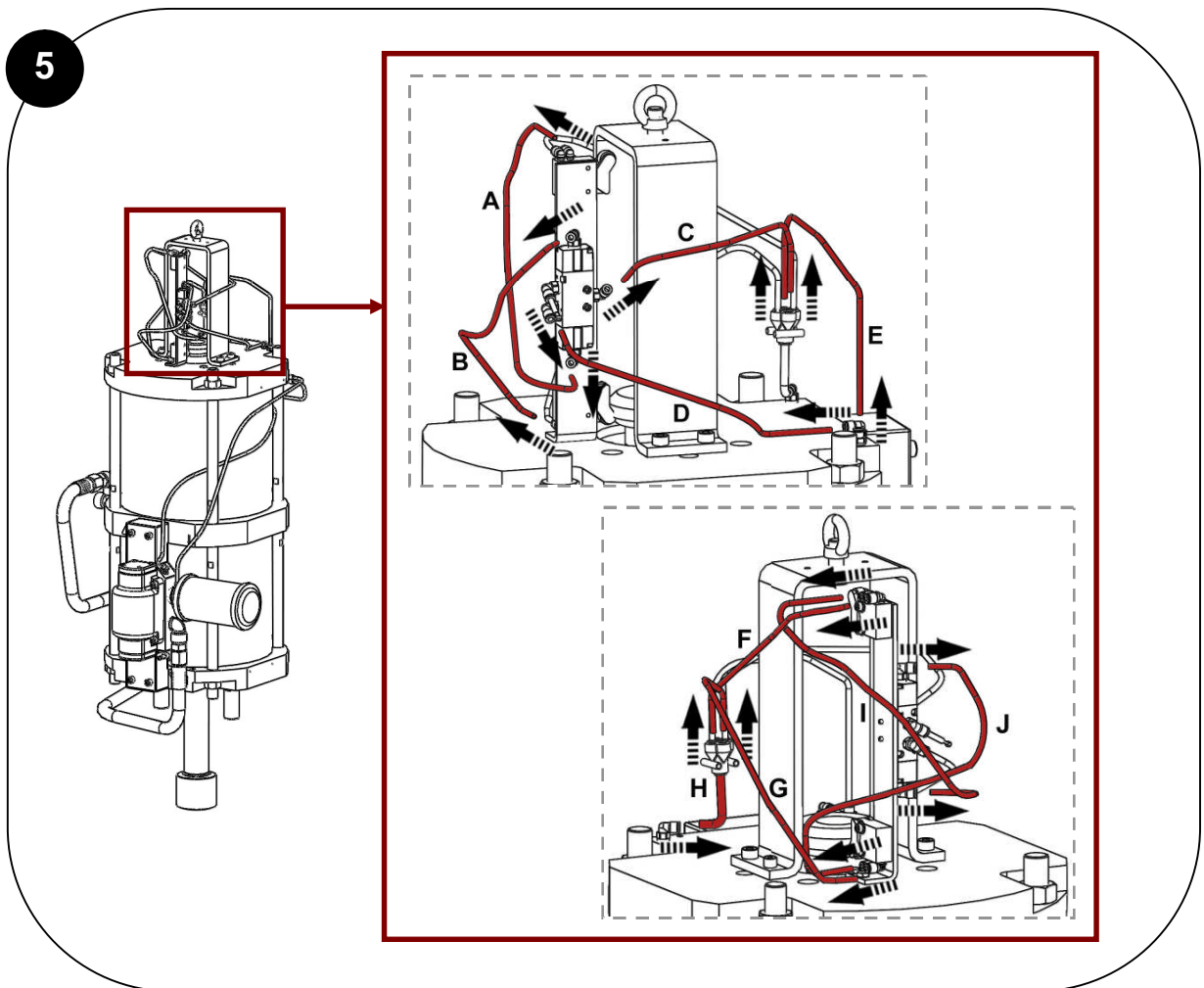
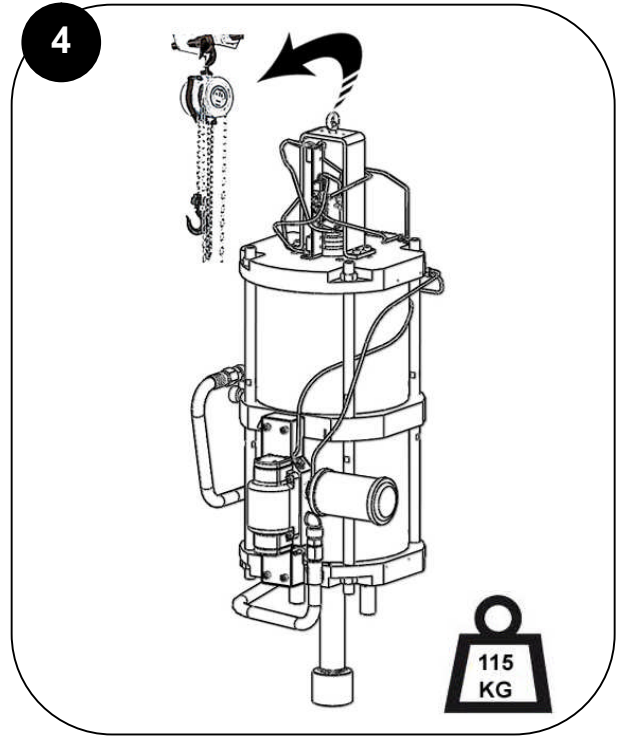
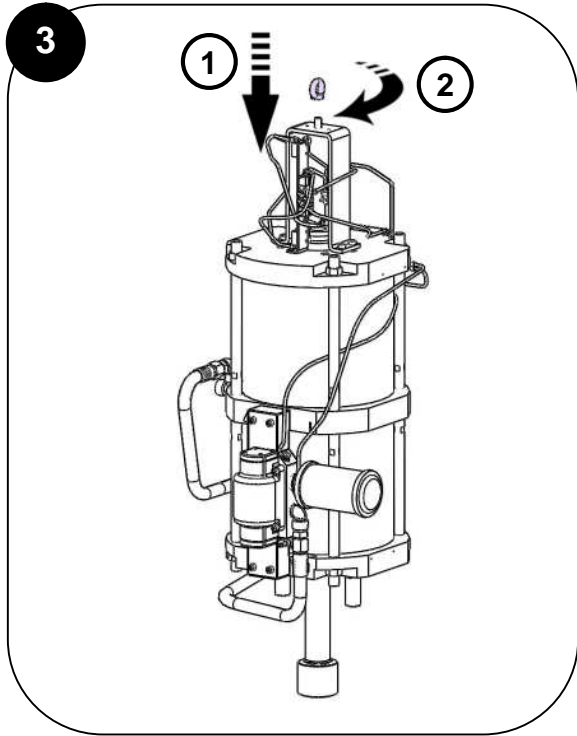

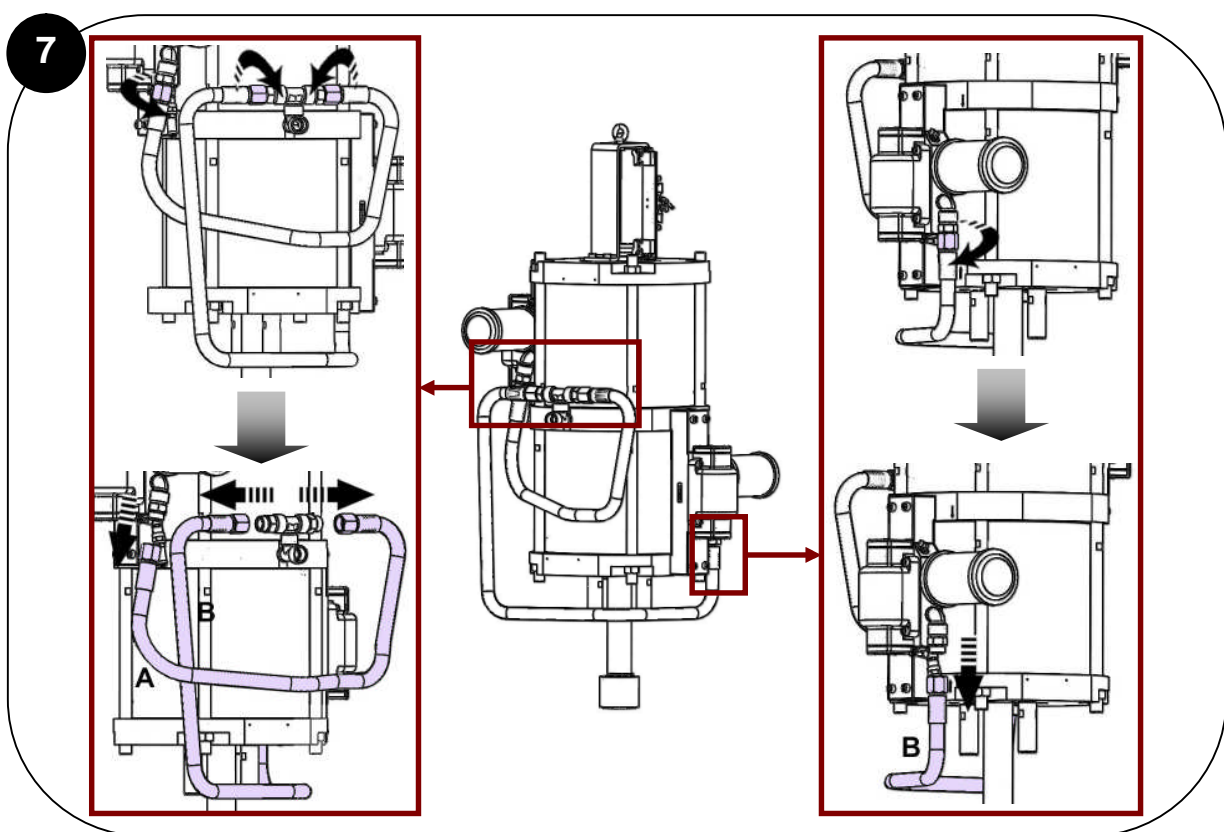
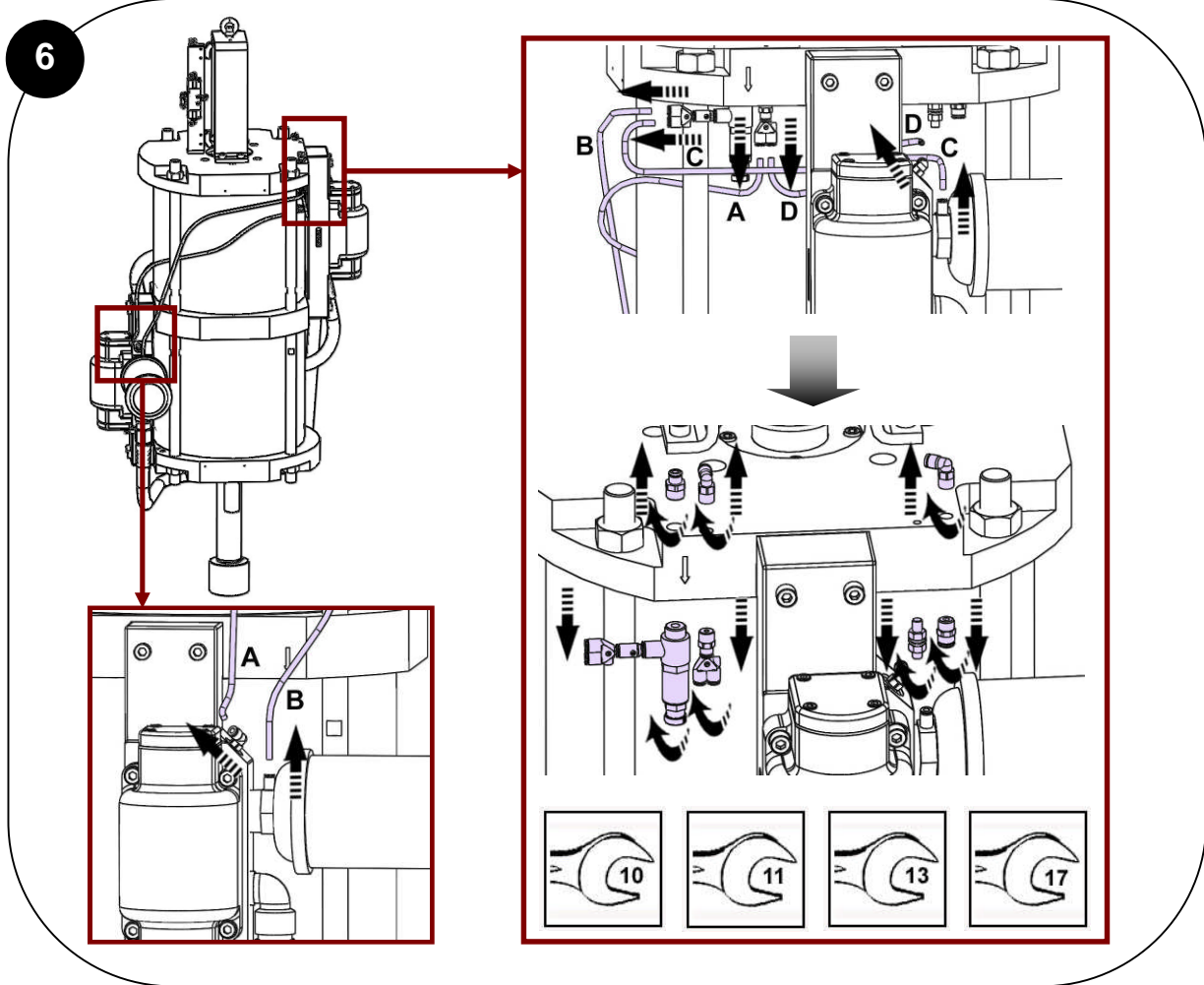

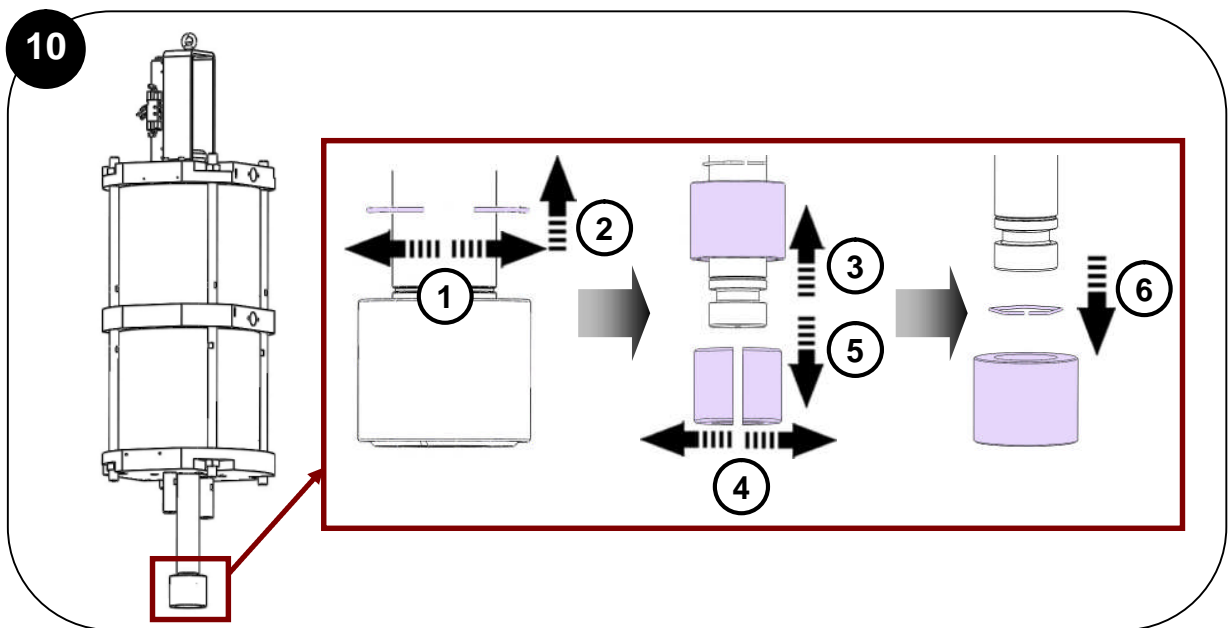
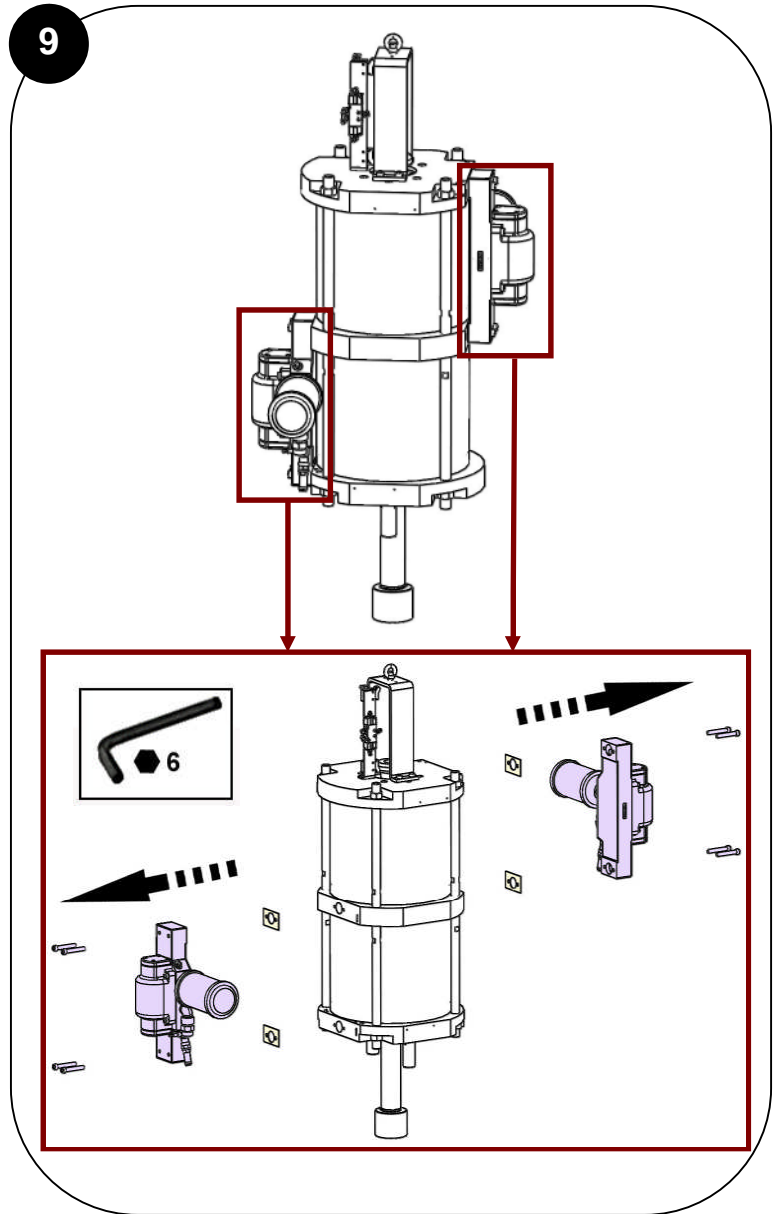
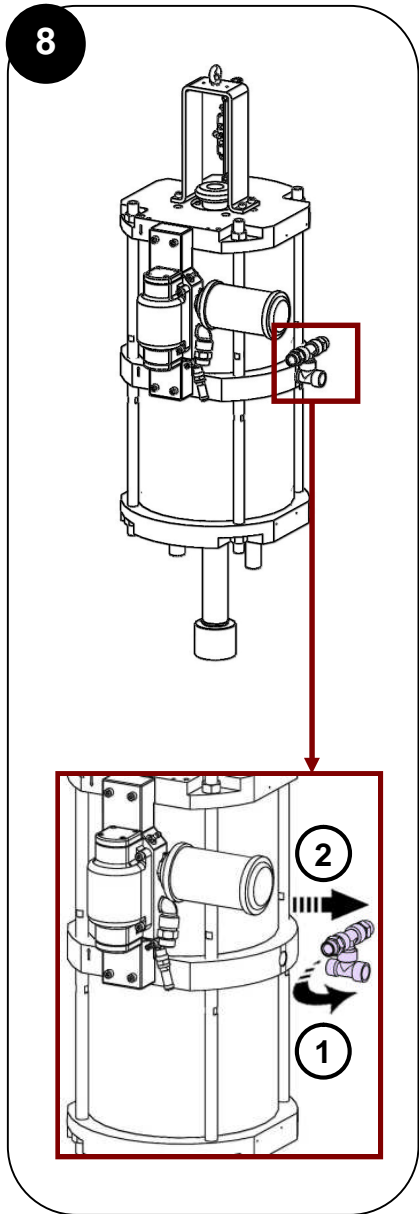

11

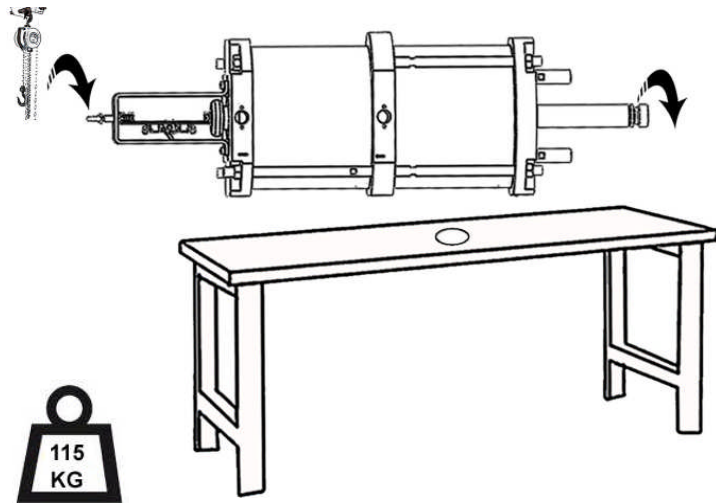

12

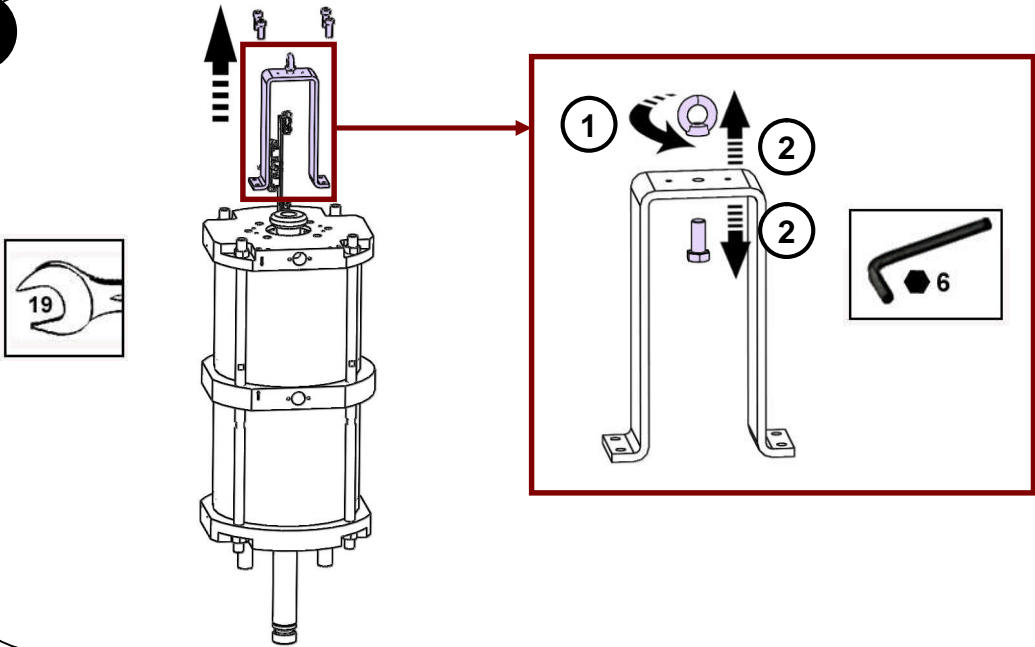

13

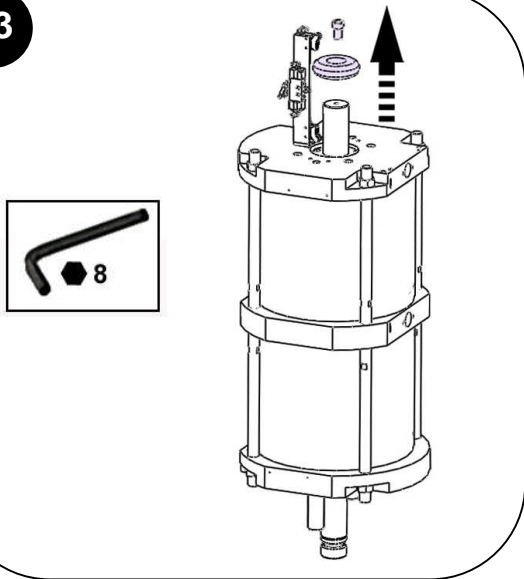

14

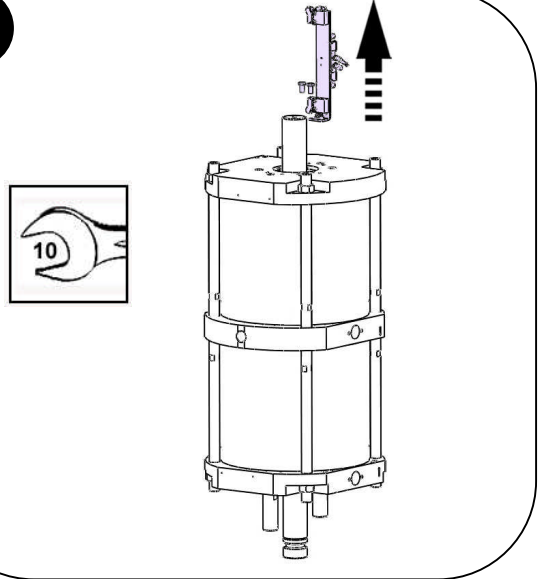

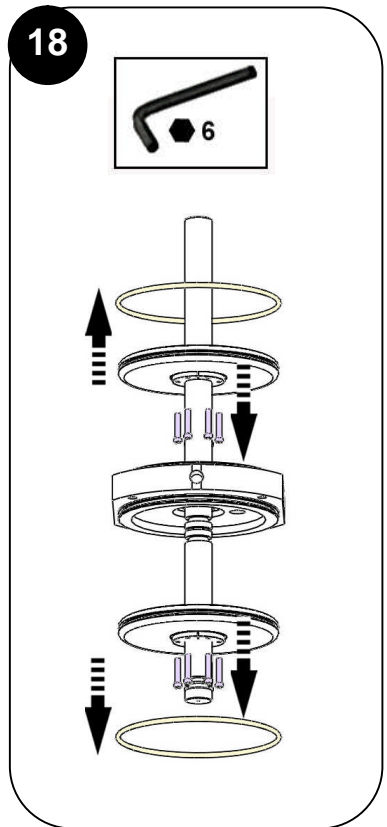
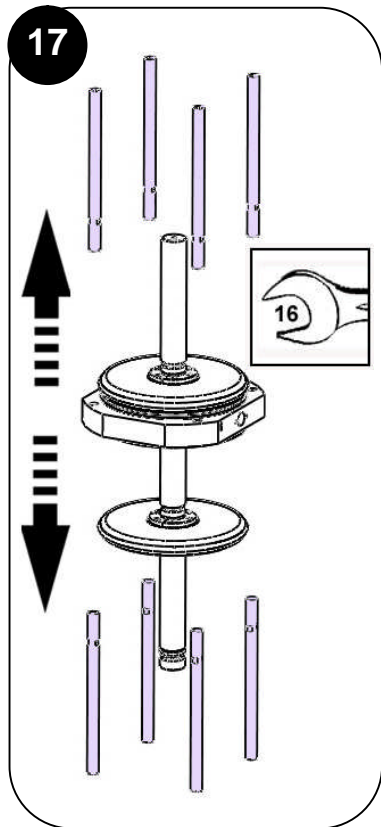
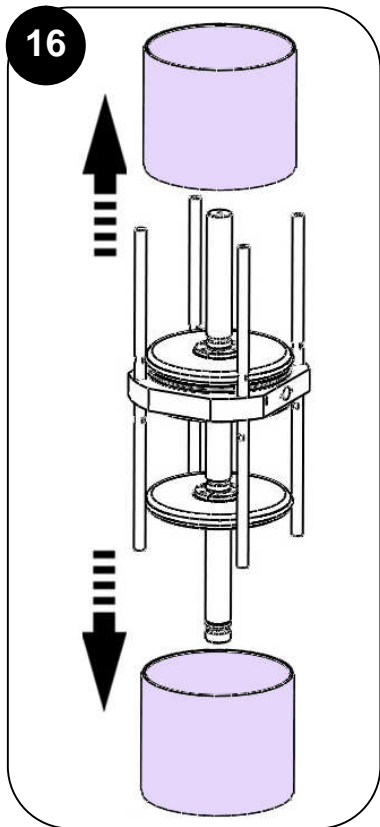
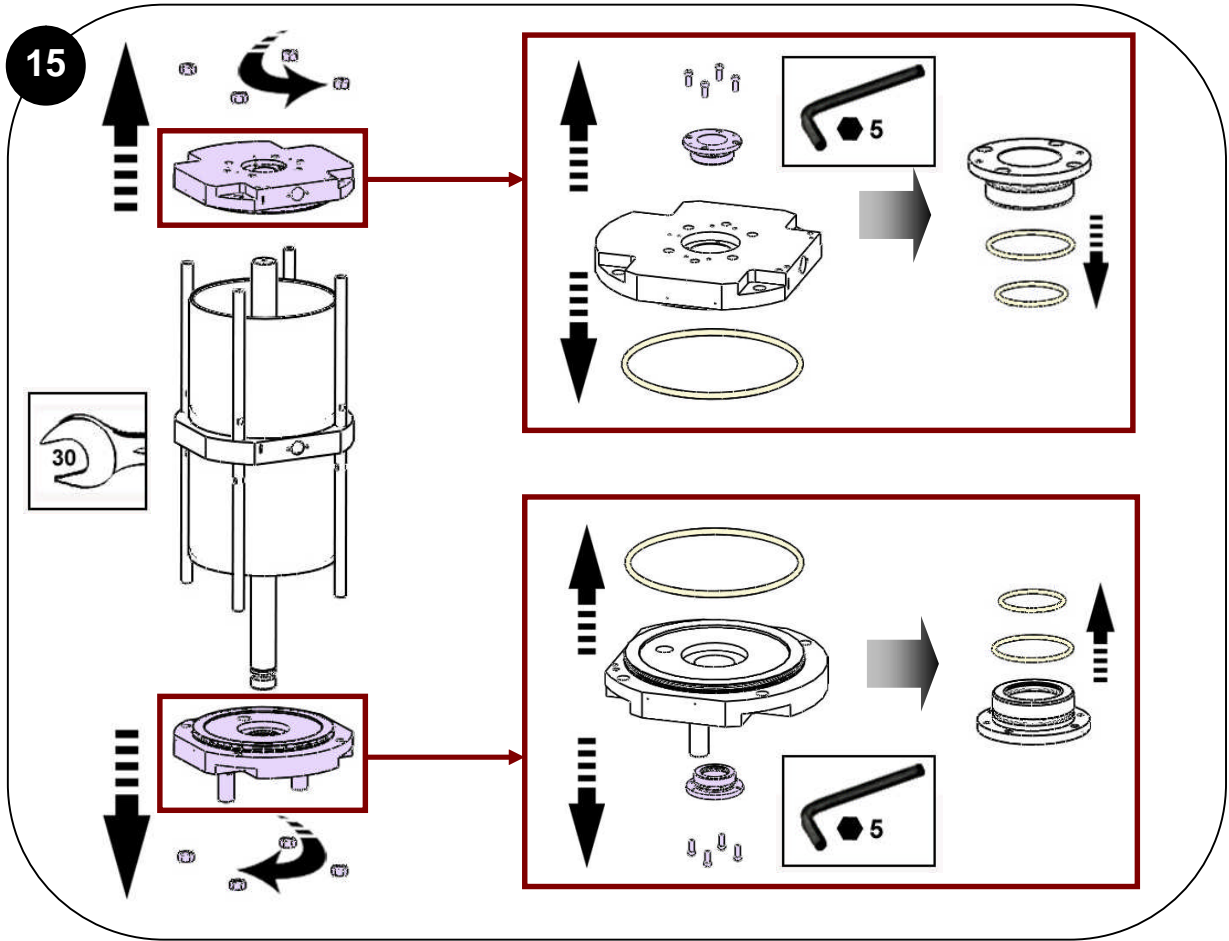

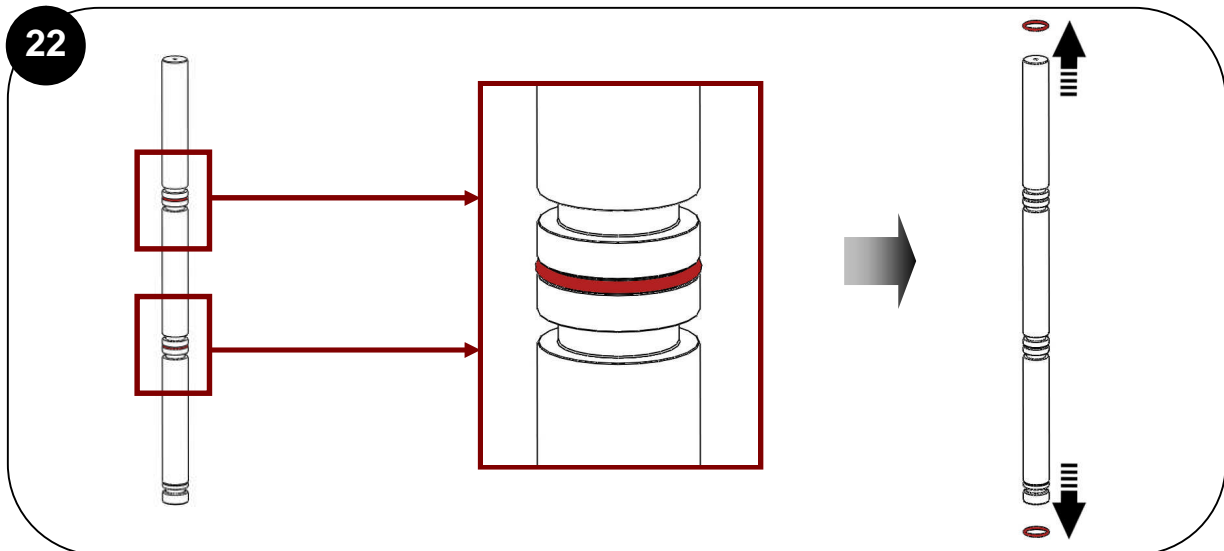
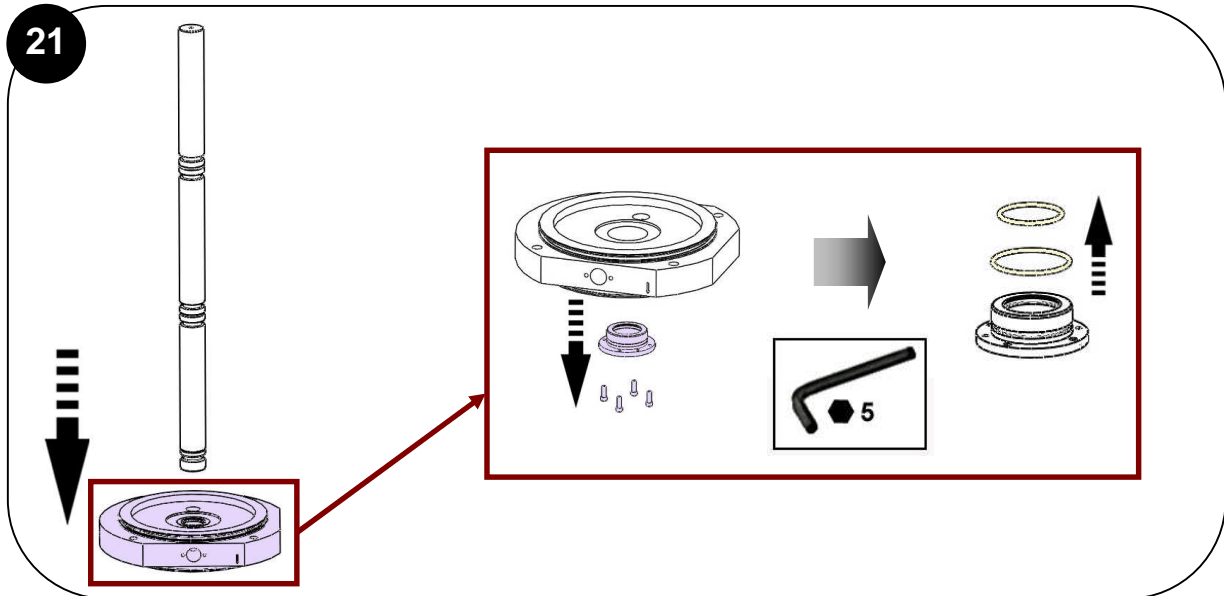
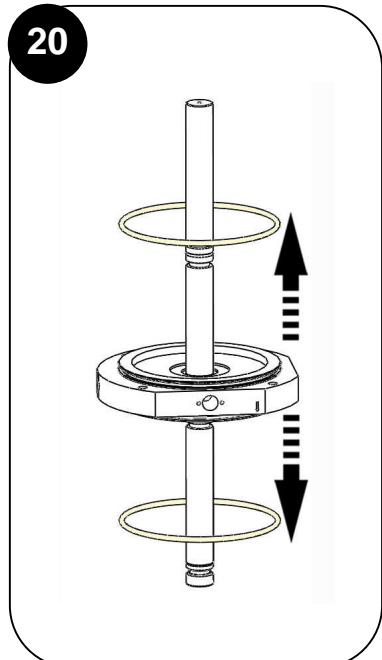
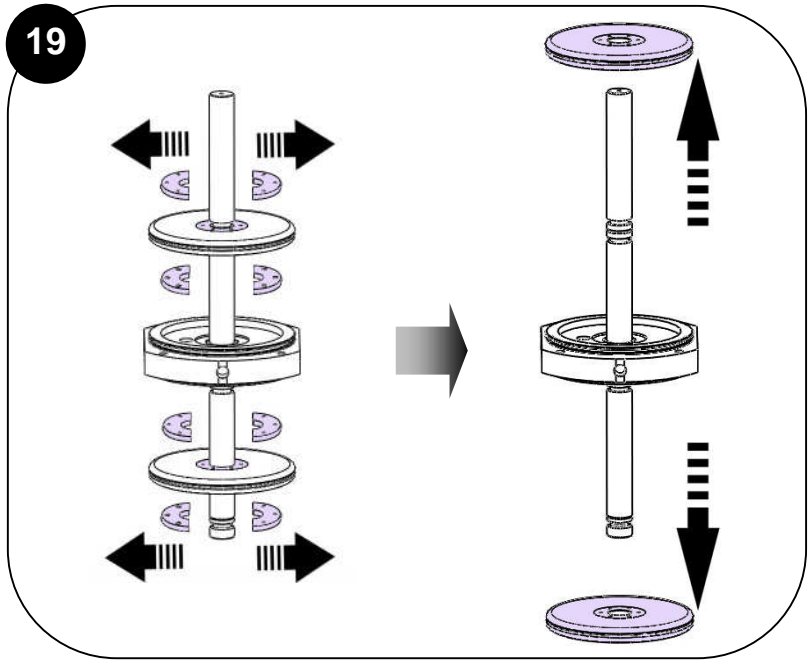

Des protecteurs (capot moteur, protecteur d'accouplement, carters,...) sont mis en place pour une utilisation sûre du matériel.

Le fabricant ne peut être tenu pour responsable en cas de dommages corporels ainsi que des pannes et / ou endommagement du matériel résultant de la destruction, de l'occultation ou du retrait total ou partiel des protecteurs.

/ Guards (air motor cover, coupling shields, housings ...) have been designed for safe use of the equipment. The manufacturer will not be held responsible for bodily injury or failure and / or damage to property due to removal or partial removal of the guards.

/ Schutzvorrichtungen an diesem Gerät, wie Motorhaube, Kupplungsschutz, Gehäuse, ggf. Erdungskabel, sowie weitere Vorrichtungen, wurden für eine sichere Benutzung dieses Gerätes entwickelt und angebracht. Der Hersteller lehnt jede Verantwortung für Körperschäden, Fehlfunktionen, Beschädigung der Geräte und jegliche andere Fehler ab, die durch die ganze oder teilweise Entfernung, Modifikation oder unsachgemäße Handhabung der Schutzvorrichtungen oder anderer Geräteteile entstehen.

/ Protectores (capó motor, protector de acoplamiento, cárteres,...) se colocan para una utilización segura del material. El fabricante no se hace responsable, en caso de daños personales, así como de las averías y / o daños del material, resultantes de la destrucción, la ocultación o la retirada total o parcial de los protectores.

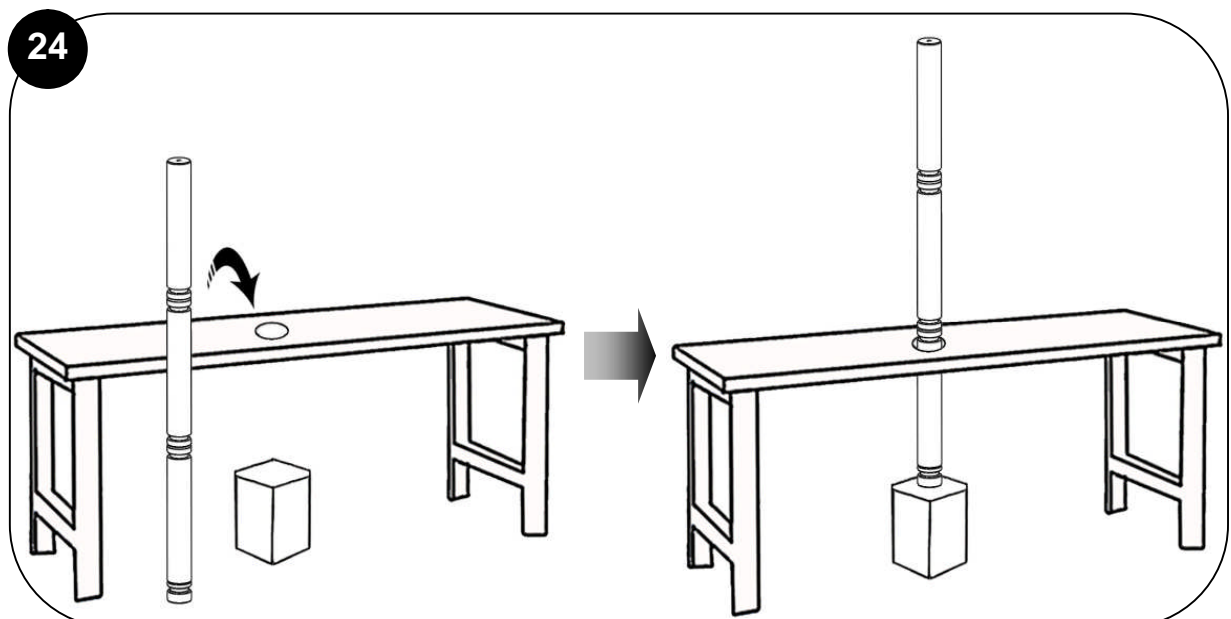
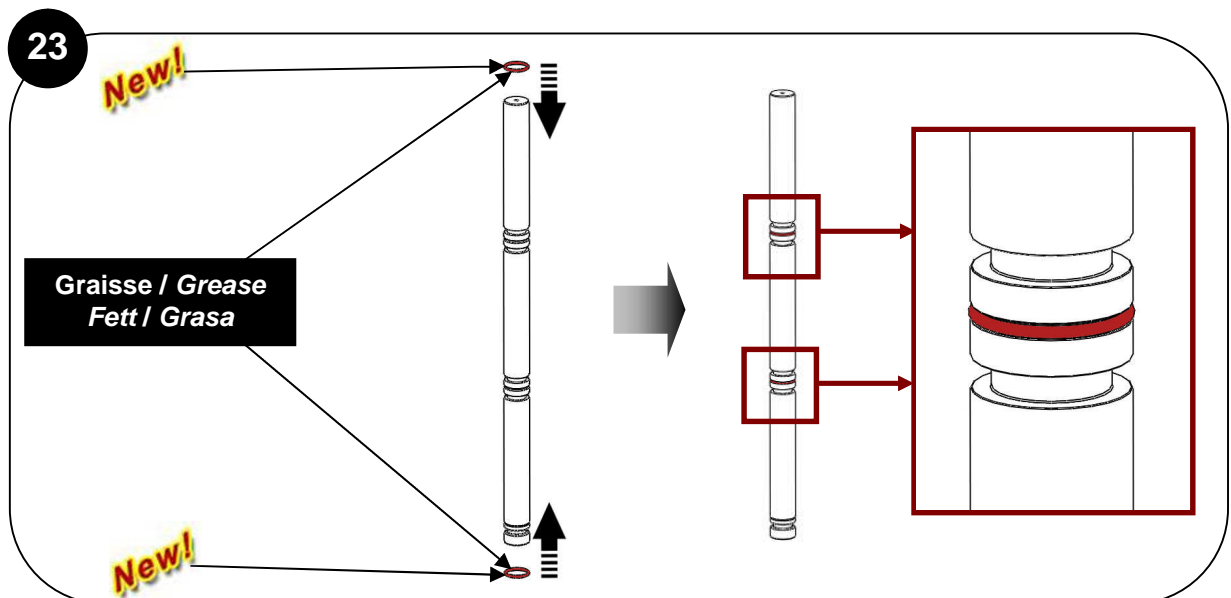

25

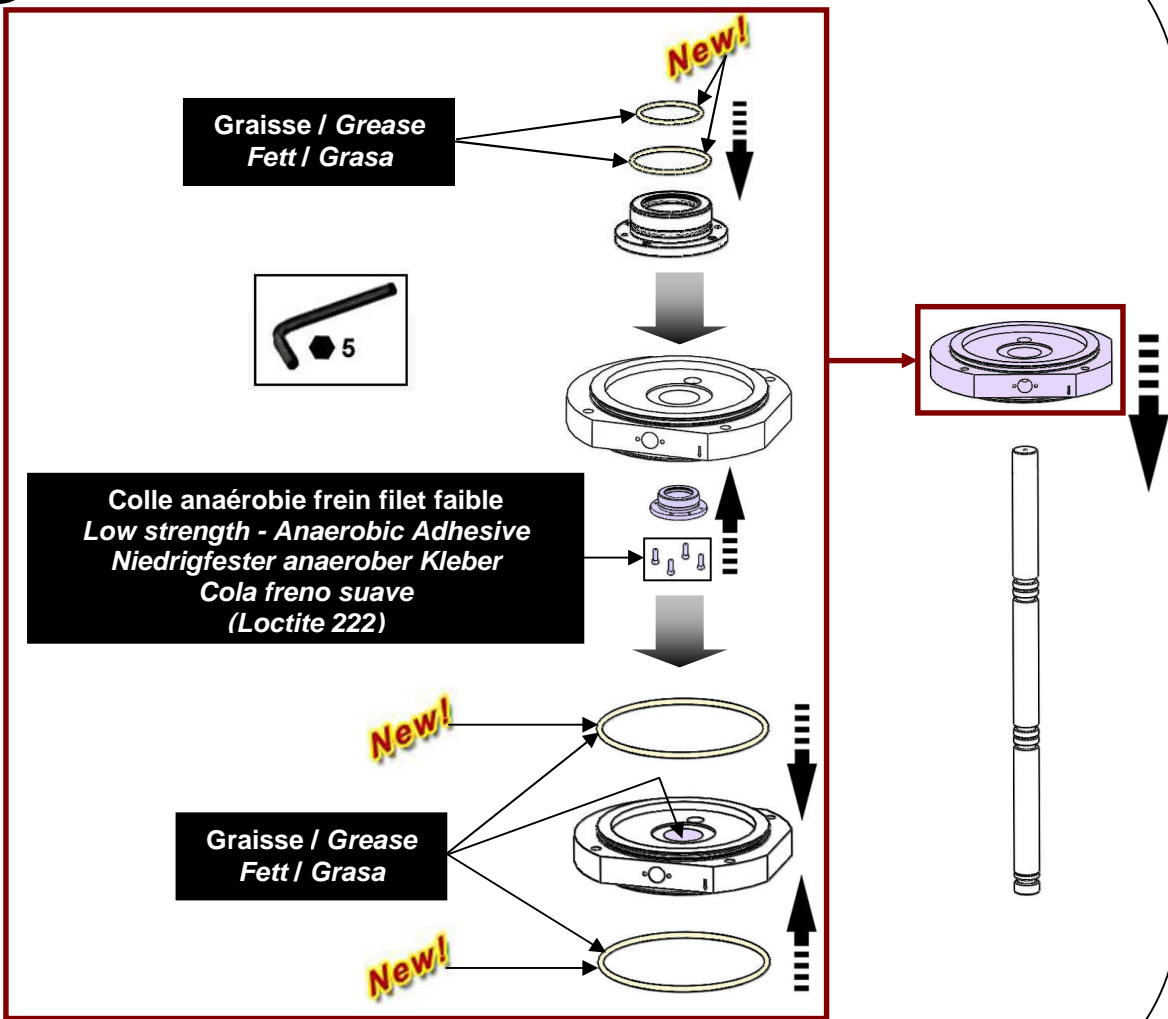

26

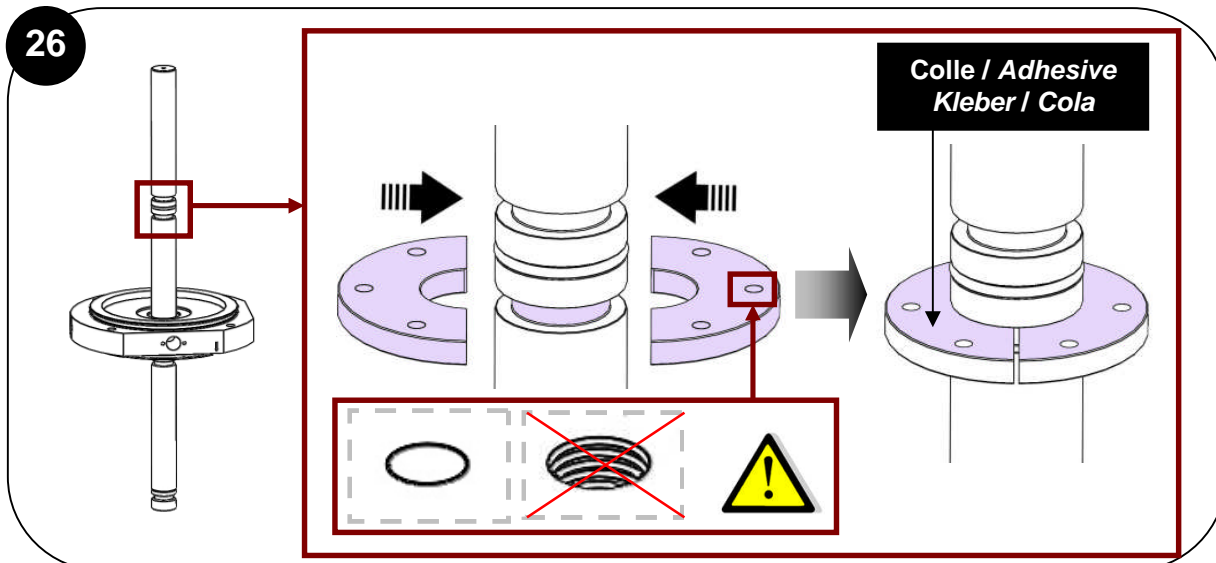



27

Graisse / Grease  
Fett / Grasa

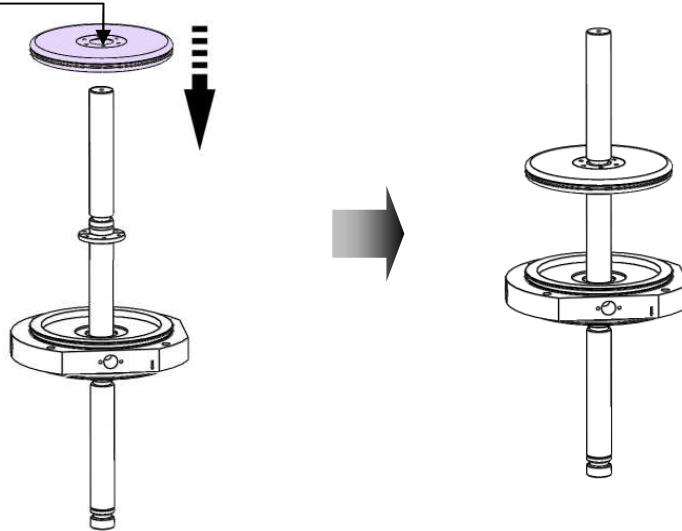

28



Colle anaérobie frein filet fort  
High strength - Anaerobic Adhesive  
Hochfester anaerober Kleber  
Cola freno forte

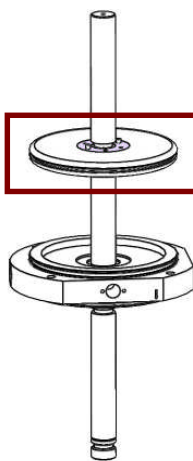
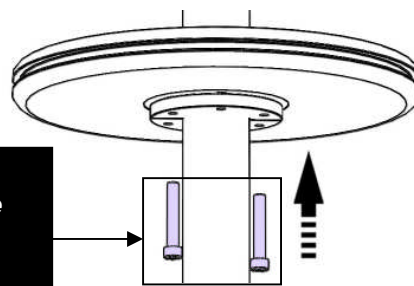

1

2

3



Colle / Adhesive  
Kleber / Cola

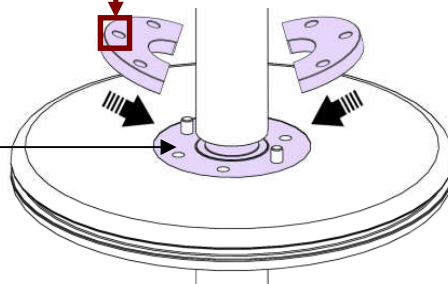

Colle anaérobie frein filet fort  
High strength - Anaerobic Adhesive  
Hochfester anaerober Kleber  
Cola freno forte

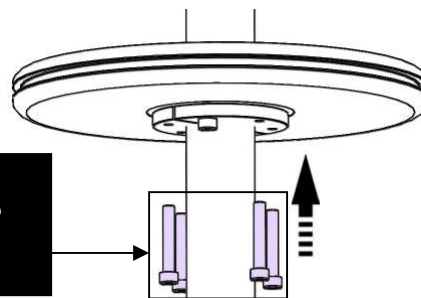

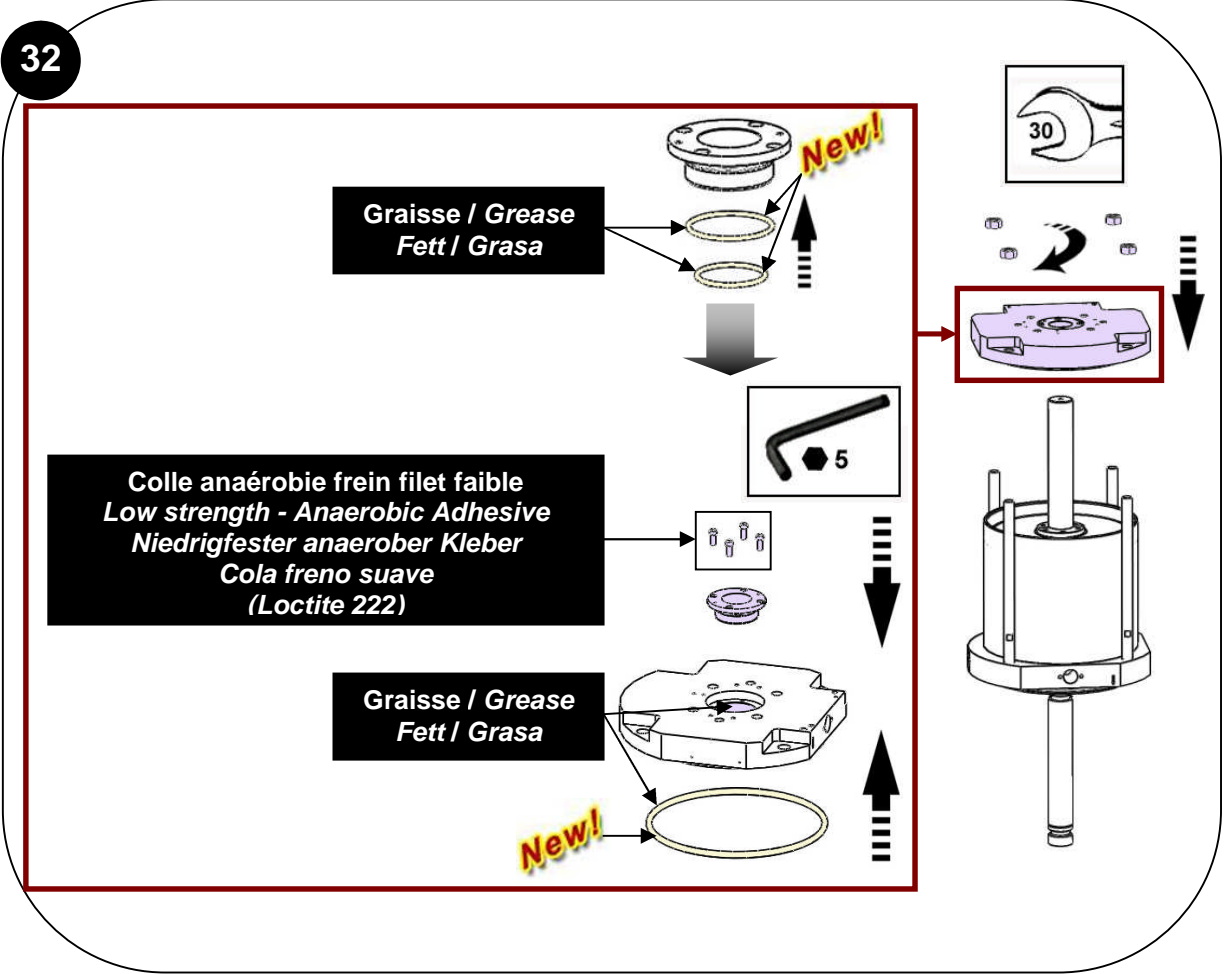
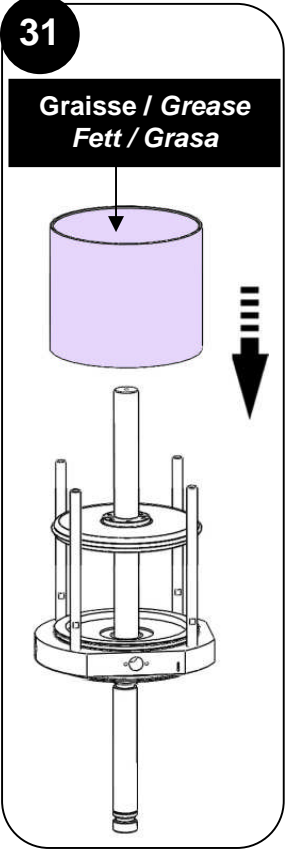
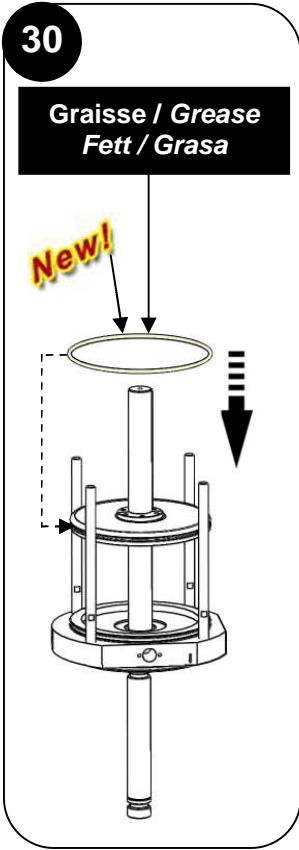
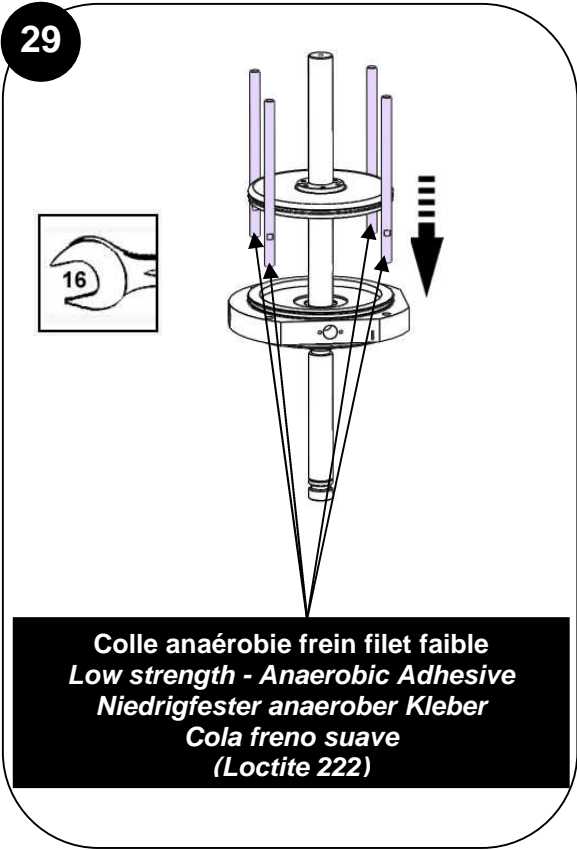

33

Faire correspondre les flèches présentes sur les flasques comme indiqué ci-contre  
 / The arrows on the flanges must match as shown in the drawing opposite  
 / Die Pfeile an den Flanschen müssen wie abgebildet zueinander zeigen  
 / Las flechas presentes sobre las bridas deben corresponder hasta respetar el croquis

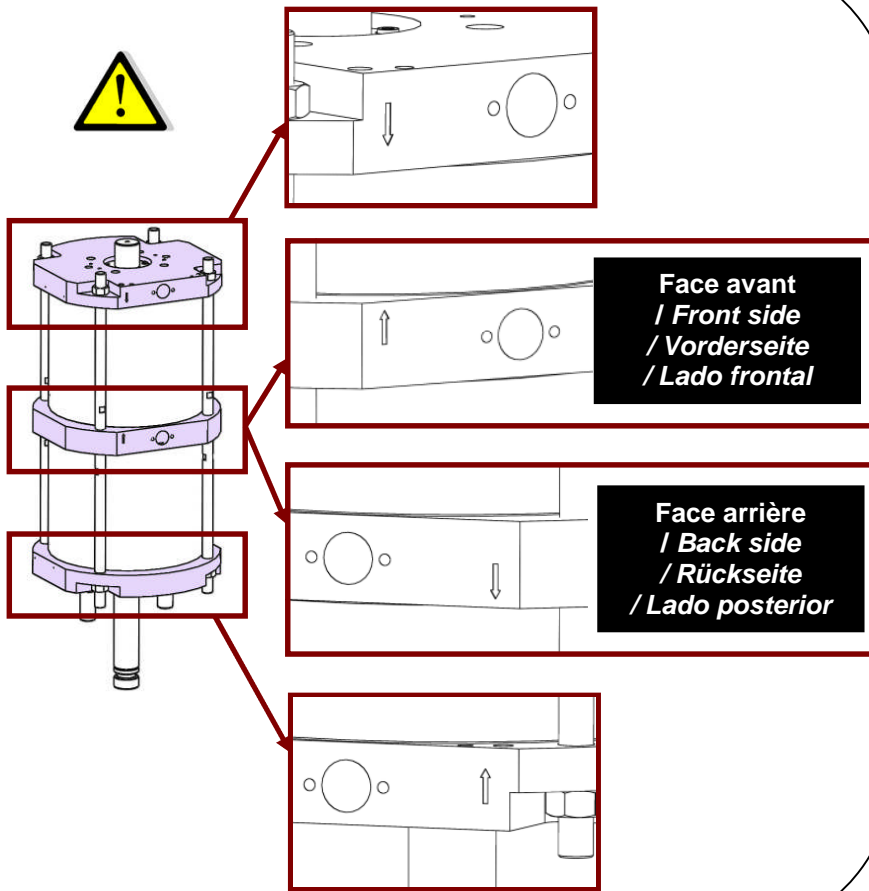

Face avant  
 / Front side  
 / Vorderseite  
 / Lado frontal

Face arrière  
 / Back side  
 / Rückseite  
 / Lado posterior

34

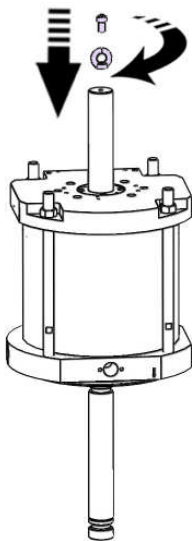

Utiliser vis de came  
 / Use cam screw  
 / Ringschraube benutzen  
 / Utilizar tornillo de leva

35

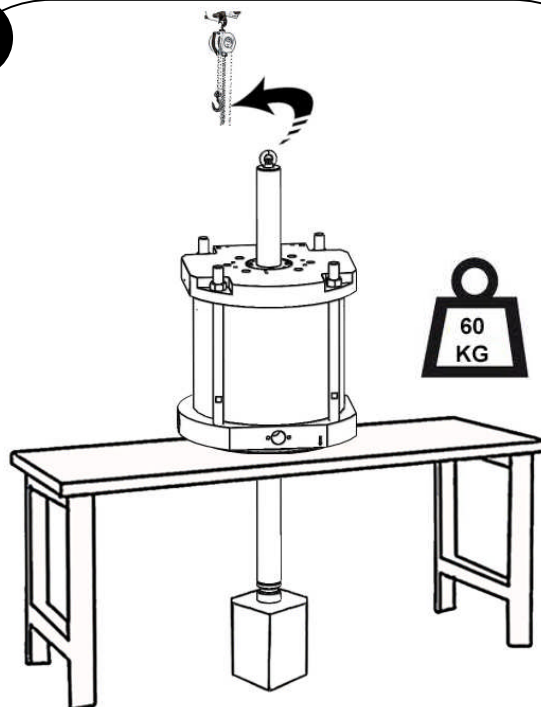

36

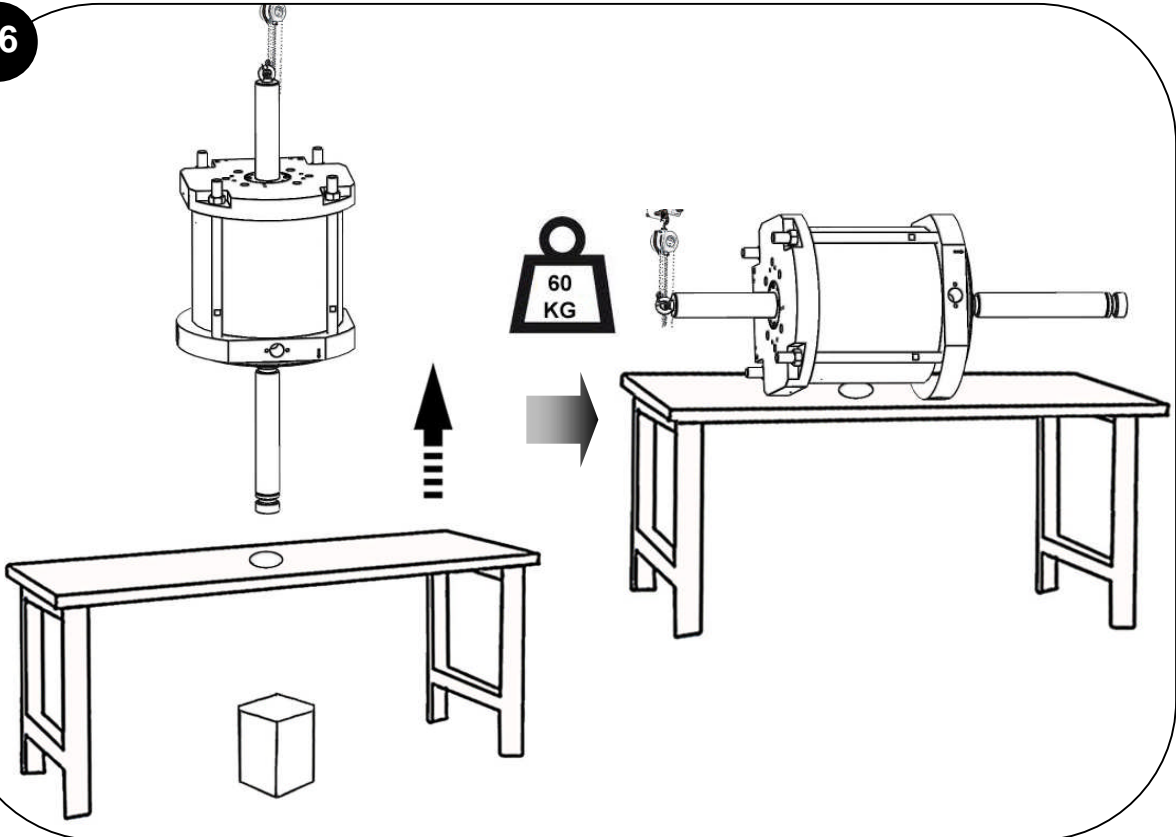

37

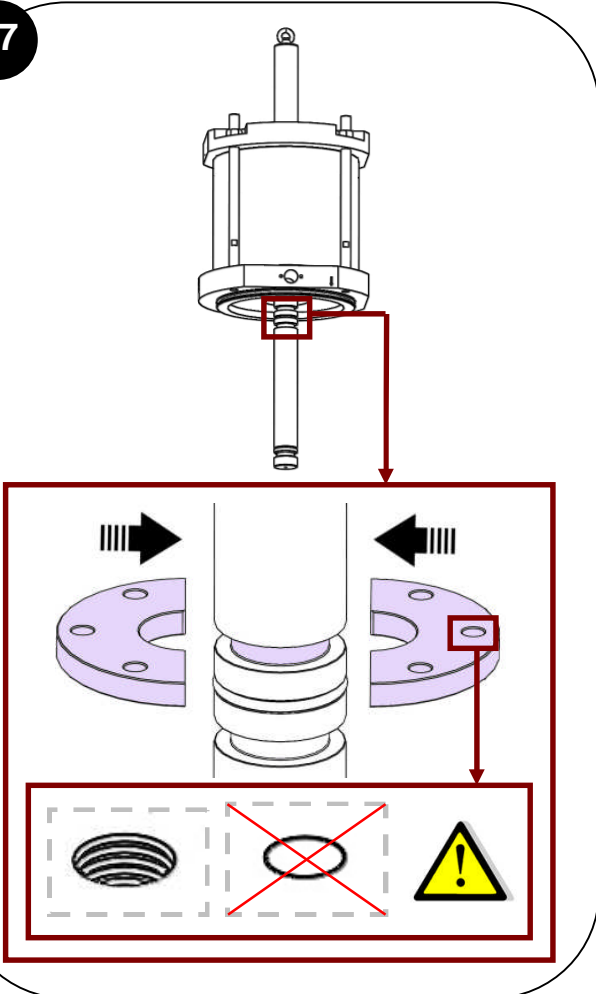

38

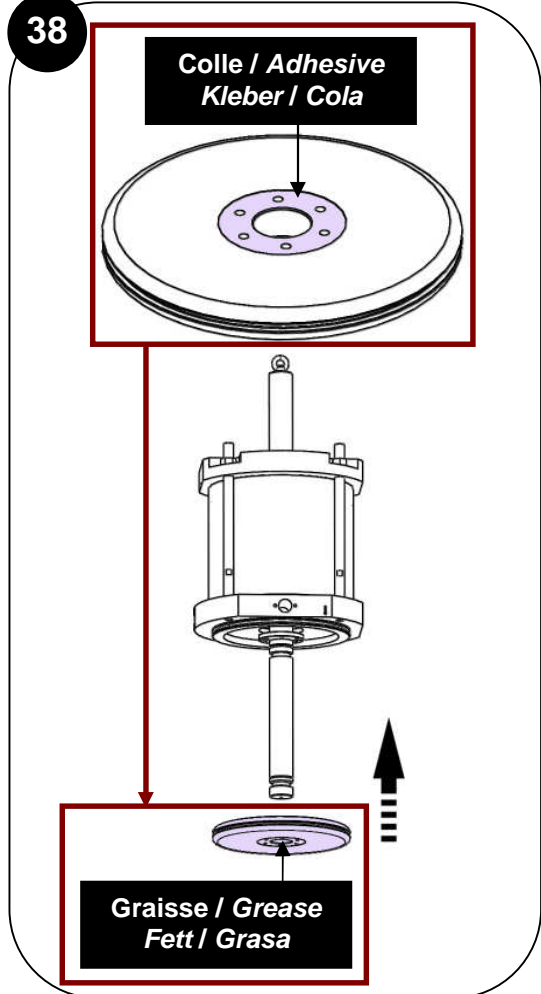

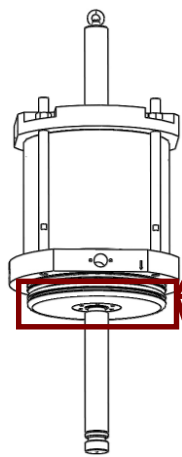

1

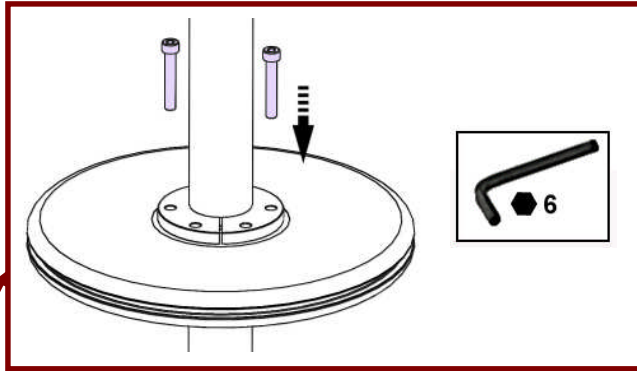

2

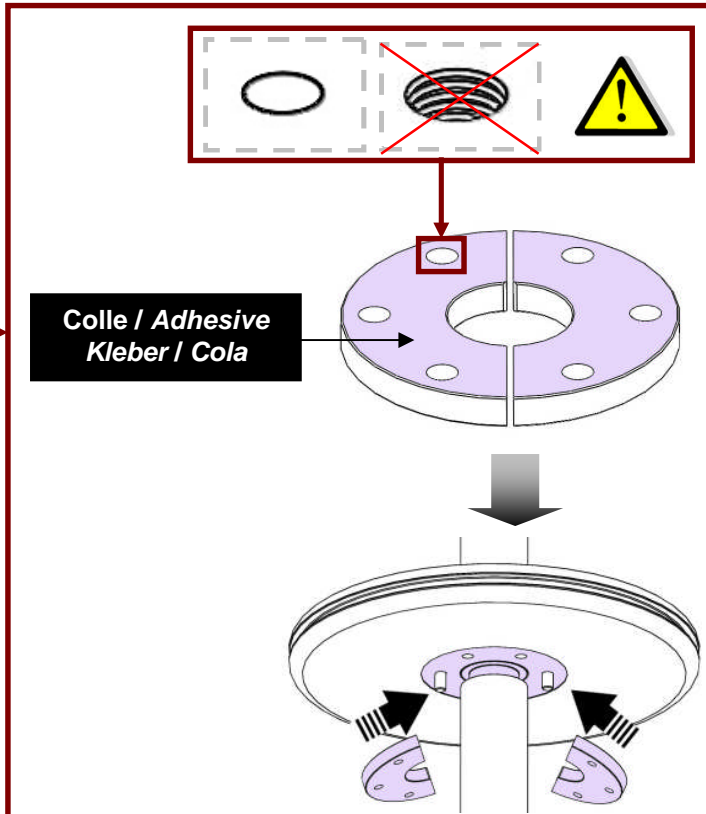

3

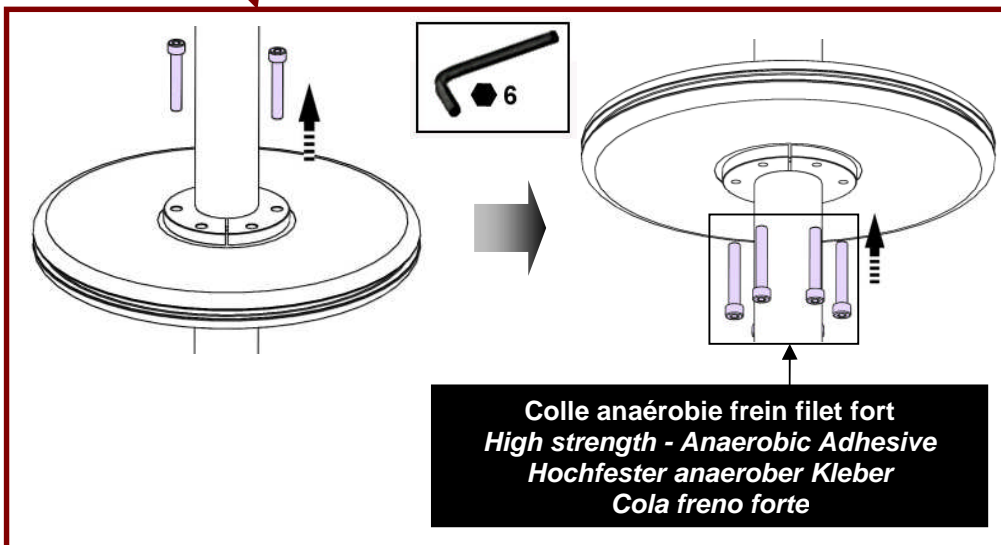

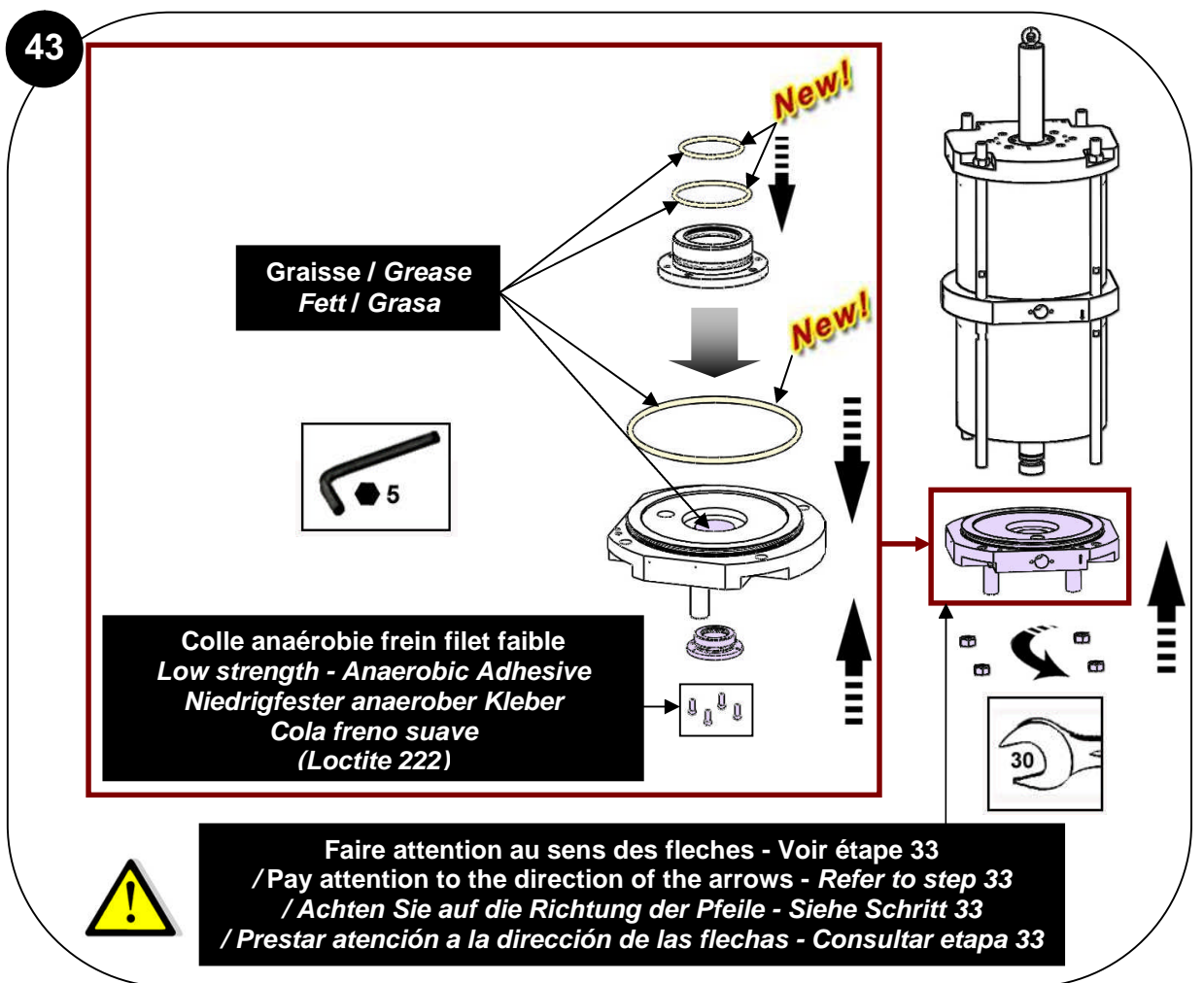
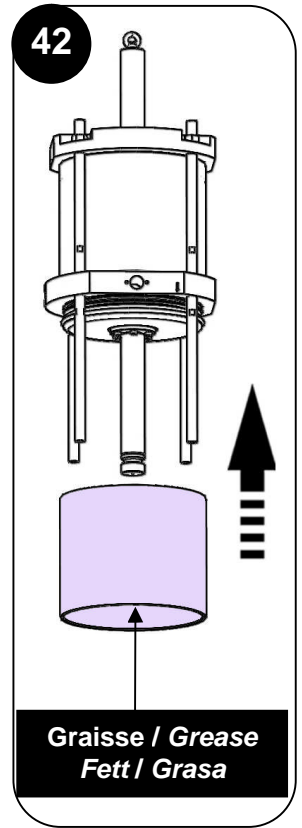
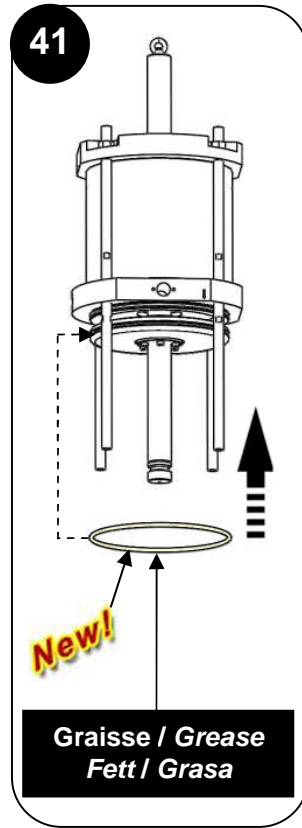
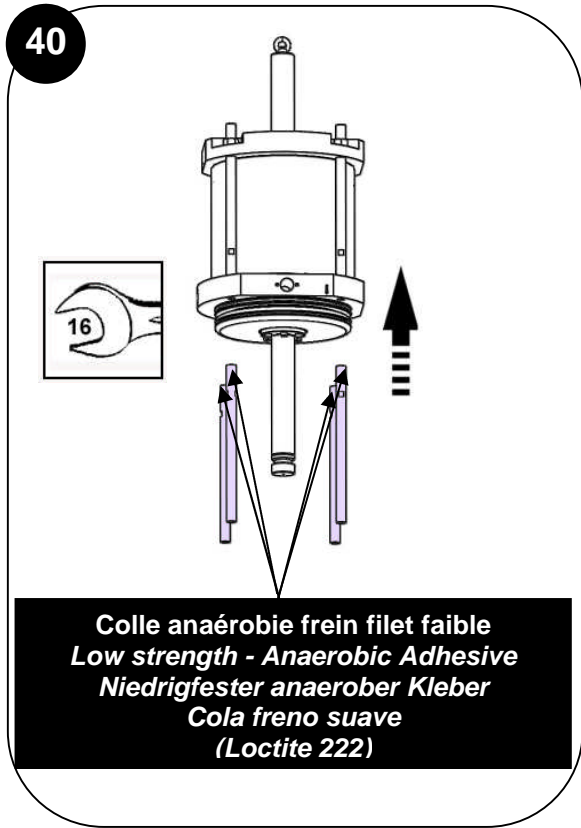

44

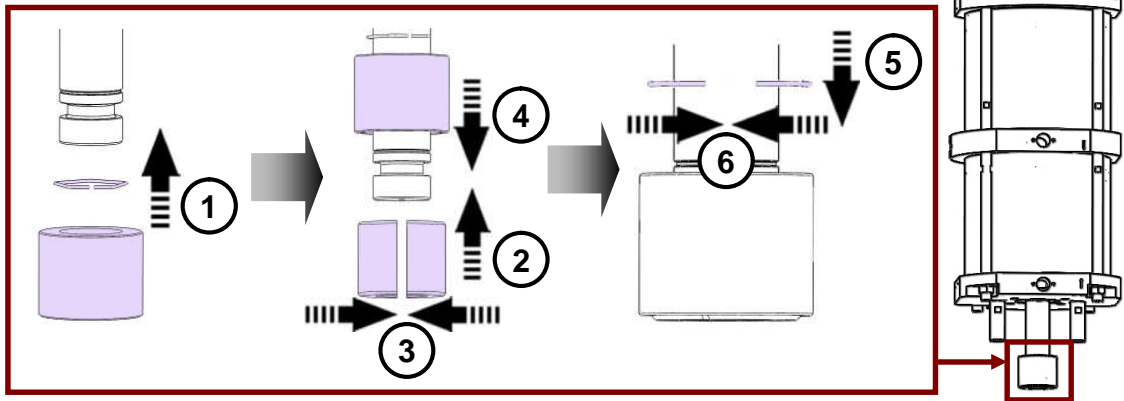

45

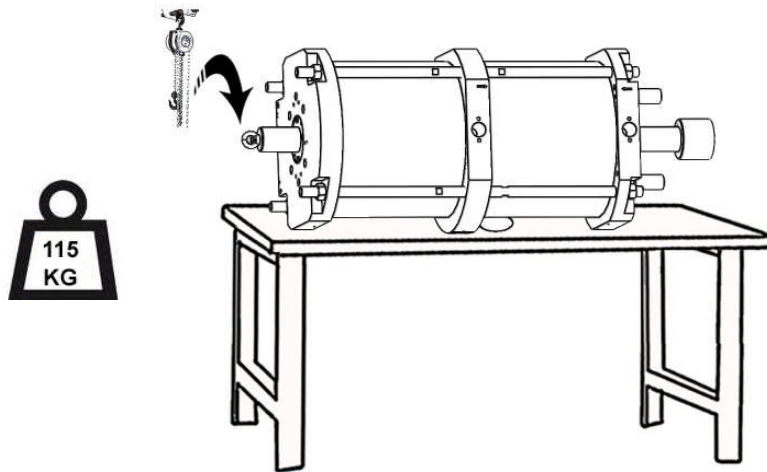

46

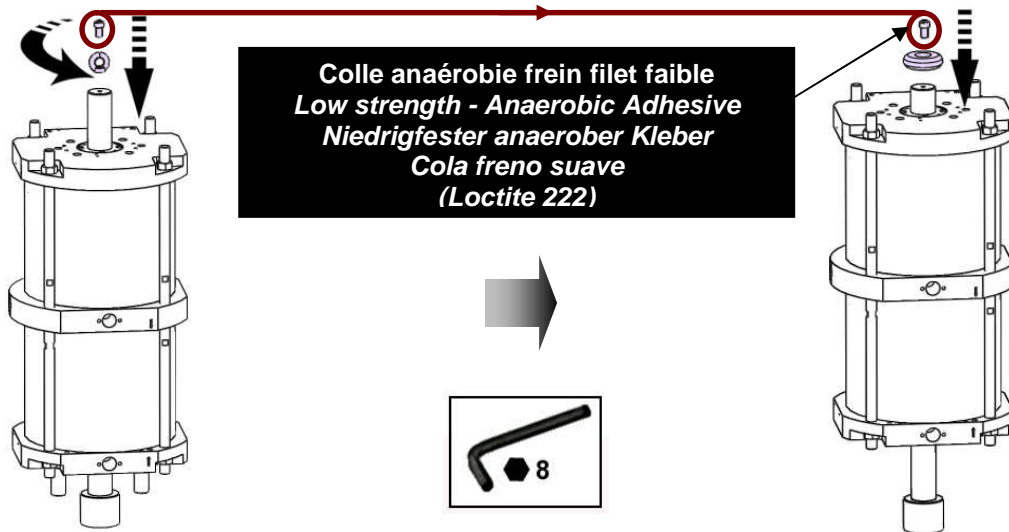

47

Colle anaérobie frein filet faible  
Low strength - Anaerobic Adhesive  
Niedrigfester anaerober Kleber  
Cola freno suave  
(Loctite 222)

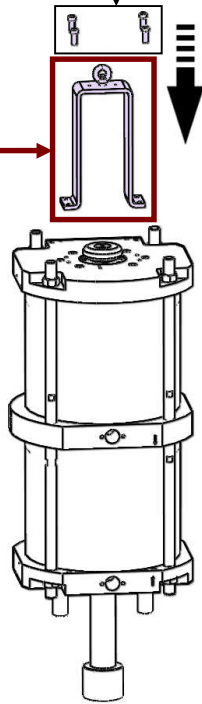
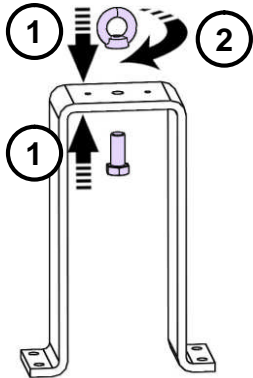

48

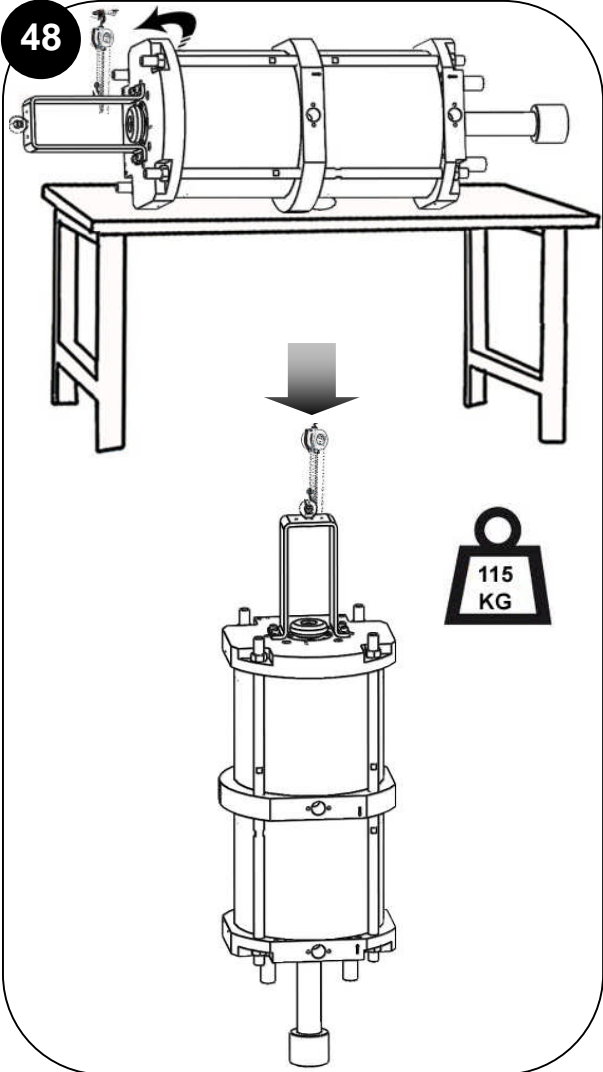

49

Colle anaérobie frein filet faible  
Low strength - Anaerobic Adhesive  
Niedrigfester anaerober Kleber  
Cola freno suave  
(Loctite 222)

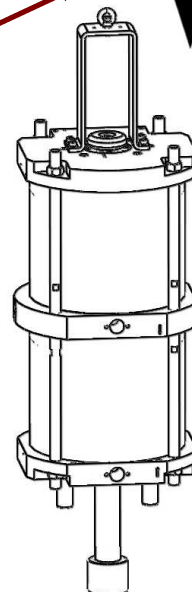
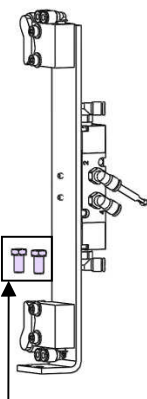
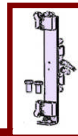



50

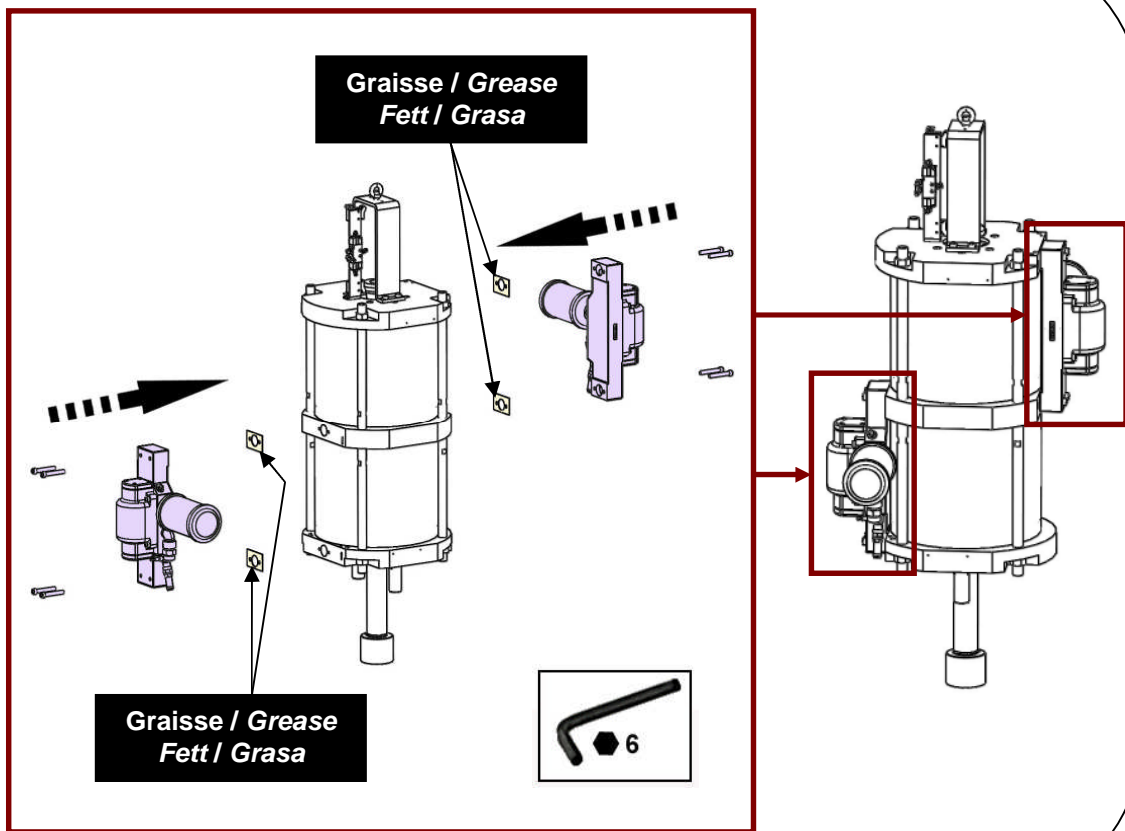

51

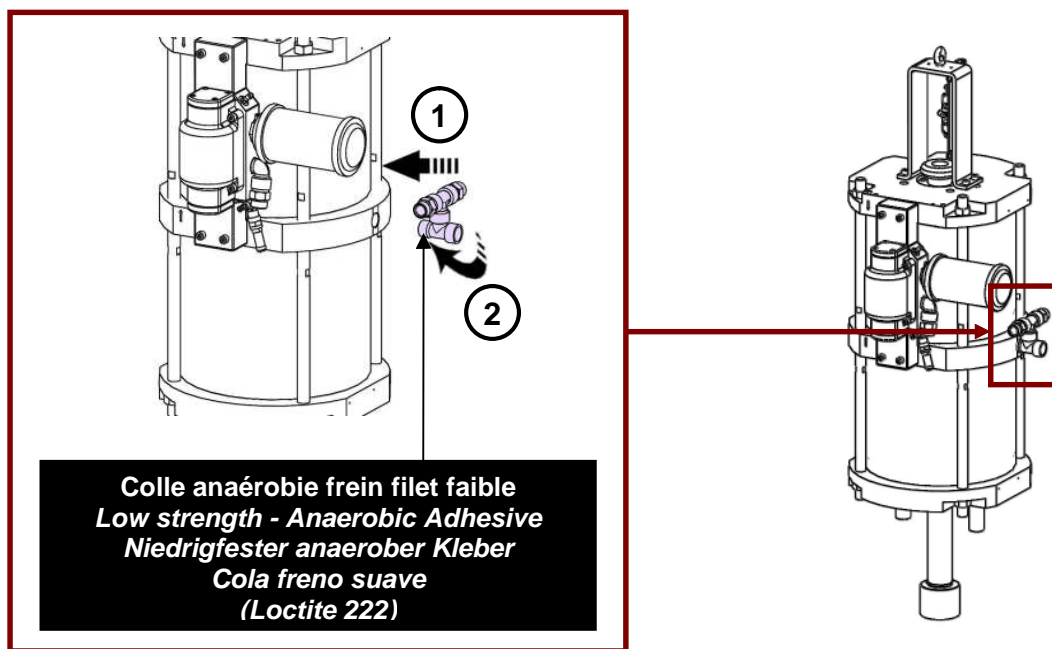

52

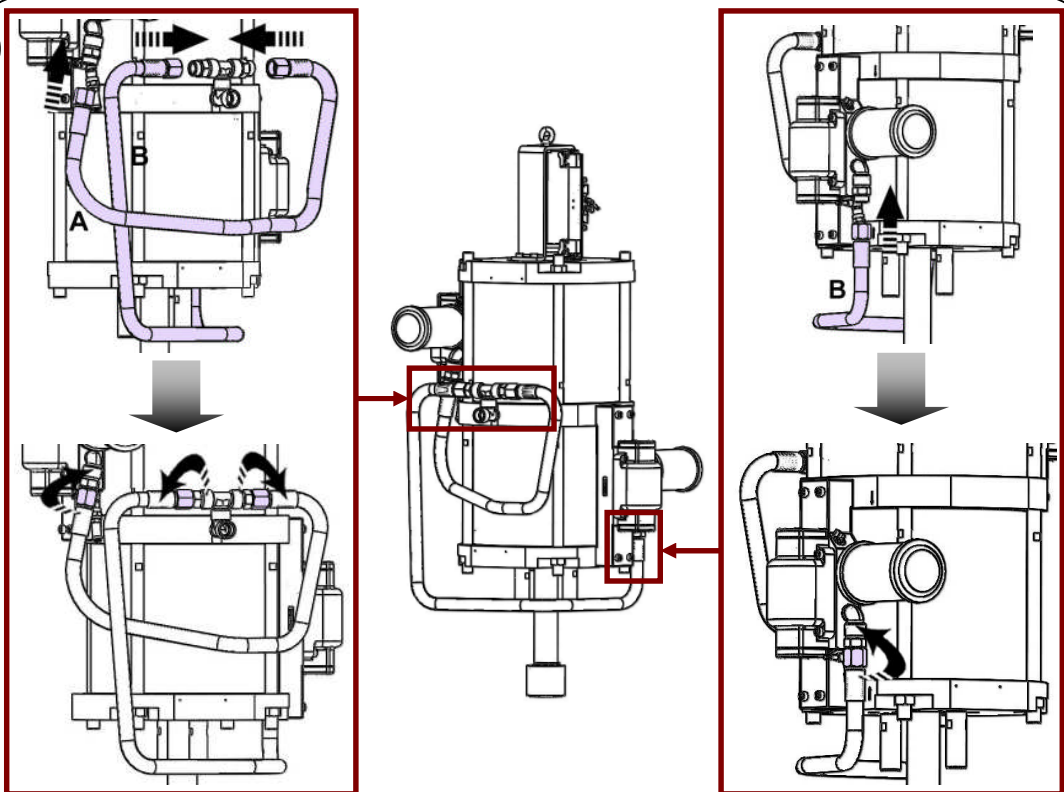

53

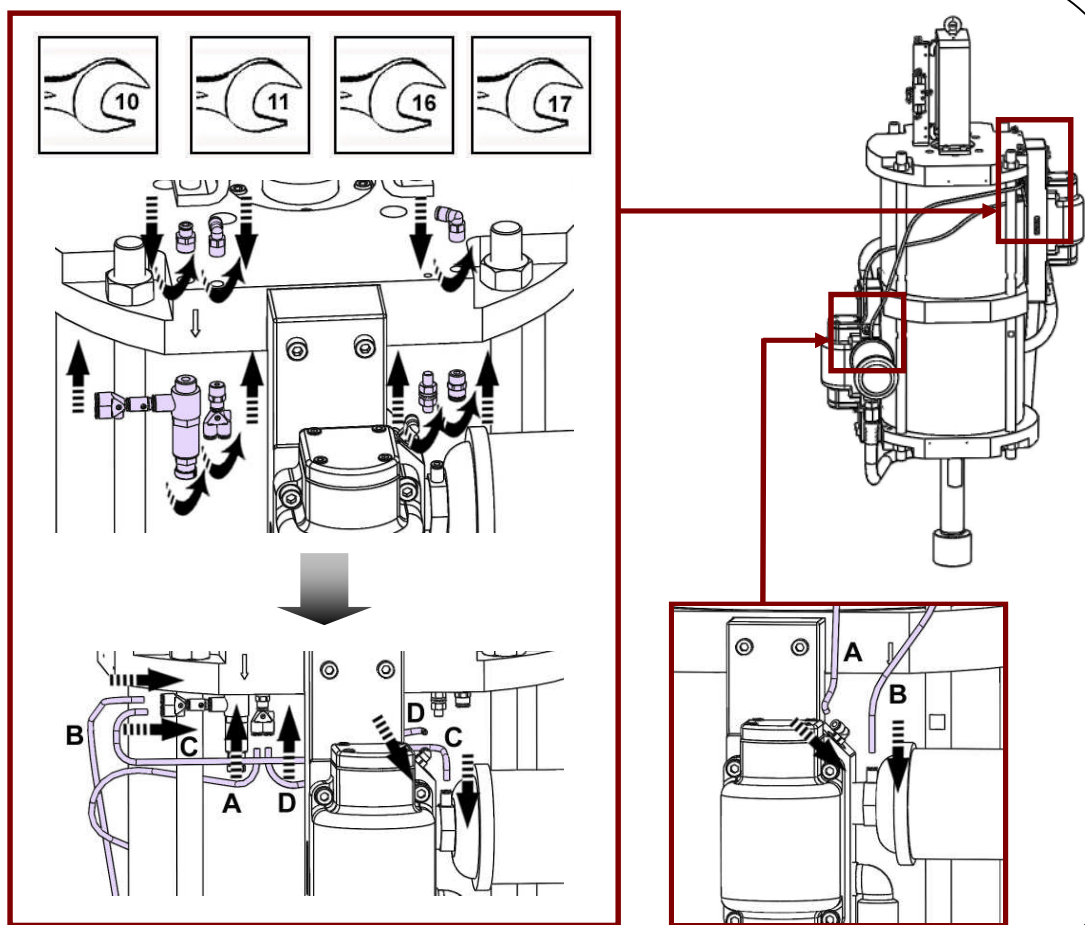

54

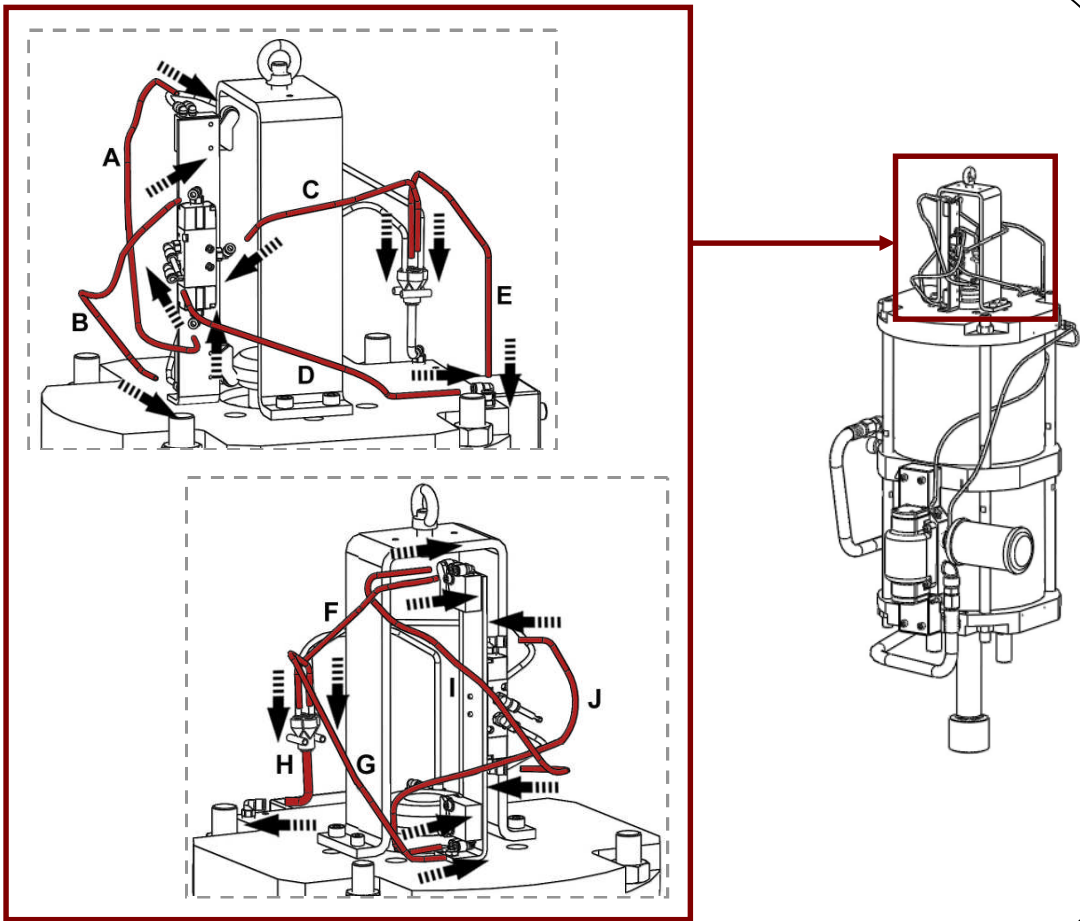

55

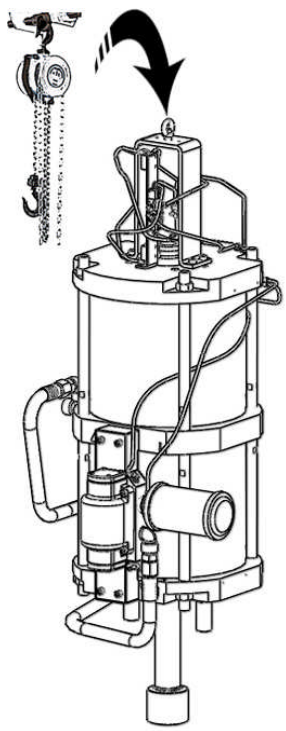

56

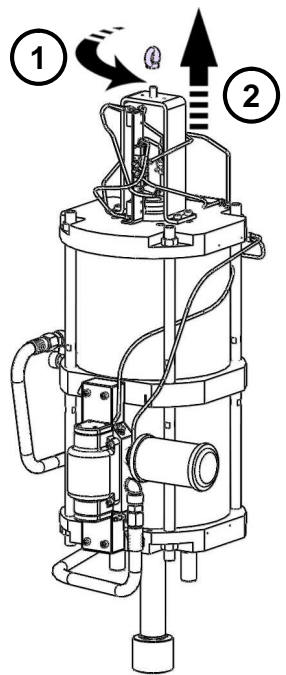

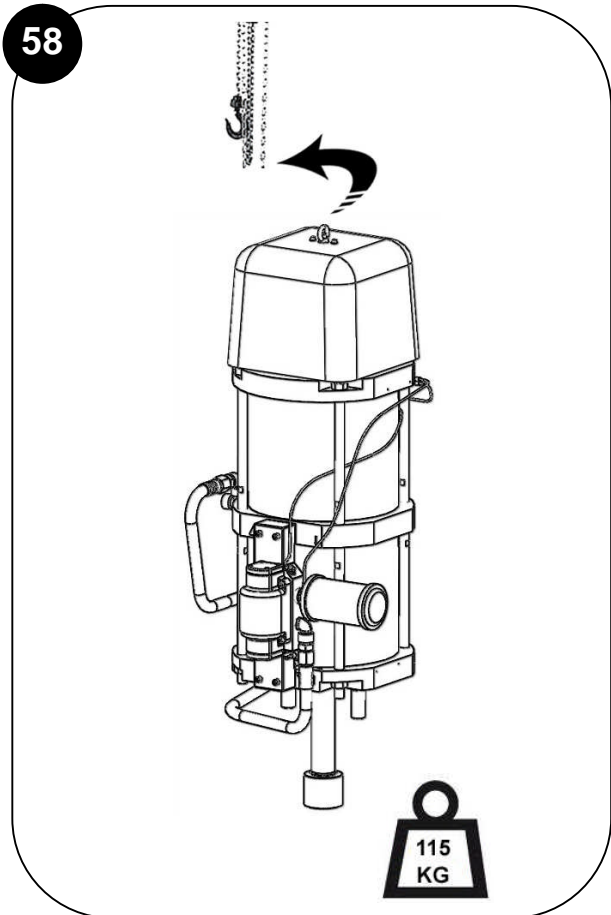
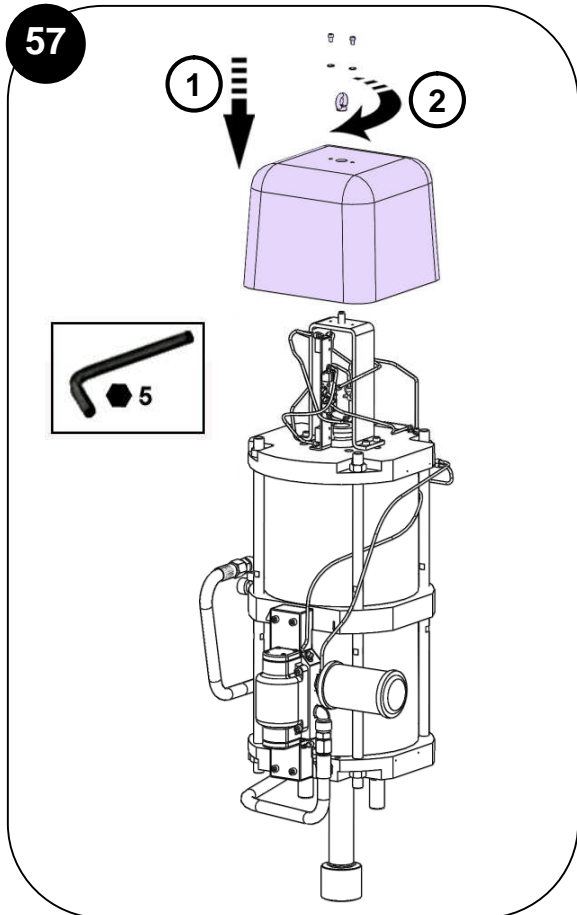

**DEMONTAGE / REMONTAGE  
DISASSEMBLY / REASSEMBLY  
DEMONTAGE / MONTAGE  
DESMONTAJE / MONTAJE**

**HYDRAULIQUE A PALETTE  
/ SHOVEL FLUID SECTION  
/ SCHÖPFKOLBEN HYDRAULIKTEIL  
/ HIDRÁULICA CON PALETA  
THOR C910-HD**

**NOTICE ORIGINALE  
/ TRANSLATION OF THE ORIGINAL MANUAL  
/ ÜBERSETZUNG DER ORIGINAL BEDIENUNGSANLEITUNG  
/ TRADUCCIÓN DEL LIBRO ORIGINAL**

**La pompe est soumise à la directive ATEX et ne doit en aucun cas être modifiée.  
Le non-respect de cette préconisation ne saurait engager notre responsabilité.  
/ The pump is manufactured under the ATEX agreement and can not be modified.  
KREMLIN REXSON will not be held responsible for any failure to comply with that instruction.**

**/ Diese Pumpe hat die ATEX Zulassung, deswegen darf sie nie verändert werden. Bei Nichtbeachtung dieser Anordnung, können wir keine Verantwortung für eine einwandfreie, regelkonforme Funktion der Pumpe übernehmen.**

**/ La bomba es de conformidad a la directiva ATEX y no debe ser modificada, en ningún caso. Kremlin Rexson no se hace responsable de que esta preconización no sea respetada.**

**Des protecteurs (capot moteur, protecteur d'accouplement, carters,...) sont mis en place pour une utilisation sûre du matériel.**

**Le fabricant ne peut être tenu pour responsable en cas de dommages corporels ainsi que des pannes et / ou endommagement du matériel résultant de la destruction, de l'occultation ou du retrait total ou partiel des protecteurs.**

**/ Guards (air motor cover, coupling shields, housings ...) have been designed for safe use of the equipment. The manufacturer will not be held responsible for bodily injury or failure and / or damage to property due to removal or partial removal of the guards.**

**/ Schutzvorrichtungen an diesem Gerät, wie Motorhaube, Kupplungsschutz, Gehäuse, ggf. Erdungskabel, sowie weitere Vorrichtungen, wurden für eine sichere Benutzung dieses Gerätes entwickelt und angebracht. Der Hersteller lehnt jede Verantwortung für Körperschäden, Fehlfunktionen, Beschädigung der Geräte und jegliche andere Fehler ab, die durch die ganze oder teilweise Entfernung, Modifikation oder unsachgemäße Handhabung der Schutzvorrichtungen oder anderer Geräteteile entstehen.**

**/ Protectores (capó motor, protector de acoplamiento, cárteres,...) se colocan para una utilización segura del material. El fabricante no se hace responsable, en caso de daños personales, así como de las averías y / o daños del material, resultantes de la destrucción, la ocultación o la retirada total o parcial de los protectores.**

***You will need / you need / Werkzeugaufstellung / Vd necesita :***

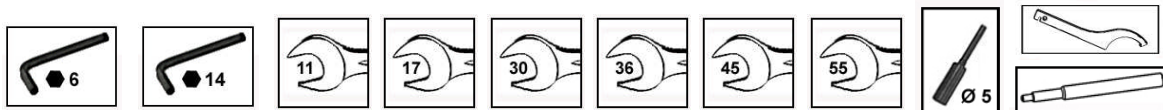

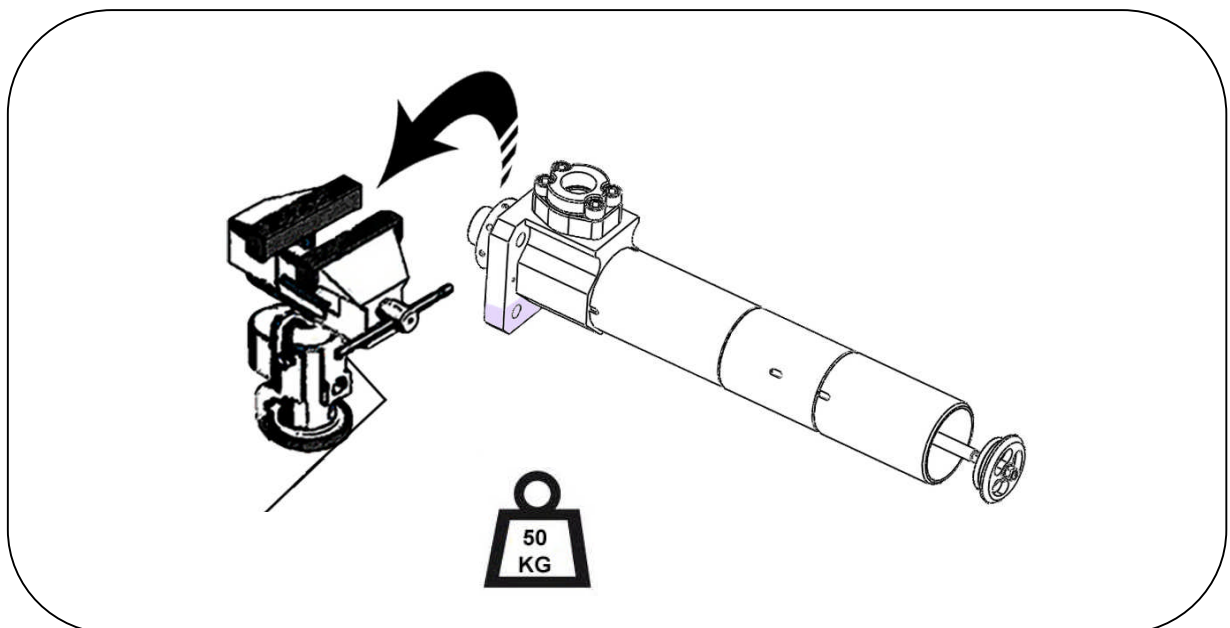
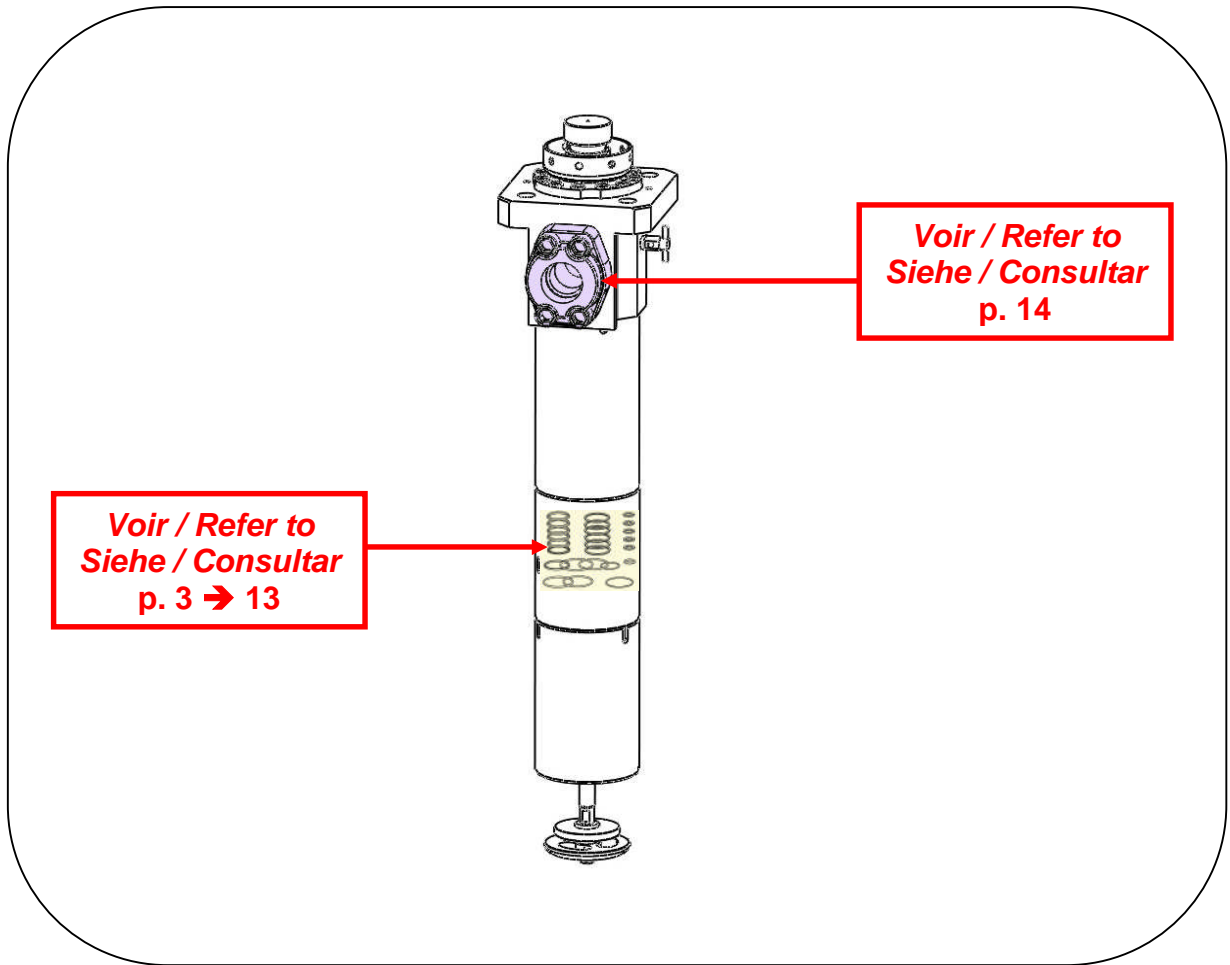

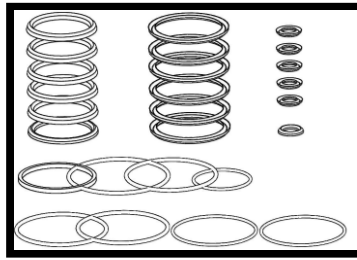

Des protecteurs (capot moteur, protecteur d'accouplement, carters,...) sont mis en place pour une utilisation sûre du matériel.

Le fabricant ne peut être tenu pour responsable en cas de dommages corporels ainsi que des pannes et / ou endommagement du matériel résultant de la destruction, de l'occultation ou du retrait total ou partiel des protecteurs.

/ Guards (air motor cover, coupling shields, housings ...) have been designed for safe use of the equipment. The manufacturer will not be held responsible for bodily injury or failure and / or damage to property due to removal or partial removal of the guards.

/ Schutzvorrichtungen an diesem Gerät, wie Motorhaube, Kupplungsschutz, Gehäuse, ggf. Erdungskabel, sowie weitere Vorrichtungen, wurden für eine sichere Benutzung dieses Gerätes entwickelt und angebracht. Der Hersteller lehnt jede Verantwortung für Körperschäden, Fehlfunktionen, Beschädigung der Geräte und jegliche andere Fehler ab, die durch die ganze oder teilweise Entfernung, Modifikation oder unsachgemäße Handhabung der Schutzvorrichtungen oder anderer Geräteteile entstehen.

/ Protectores (capó motor, protector de acoplamiento, cárteres,...) se colocan para una utilización segura del material. El fabricante no se hace responsable, en caso de daños personales, así como de las averías y / o daños del material, resultantes de la destrucción, la ocultación o la retirada total o parcial de los protectores.

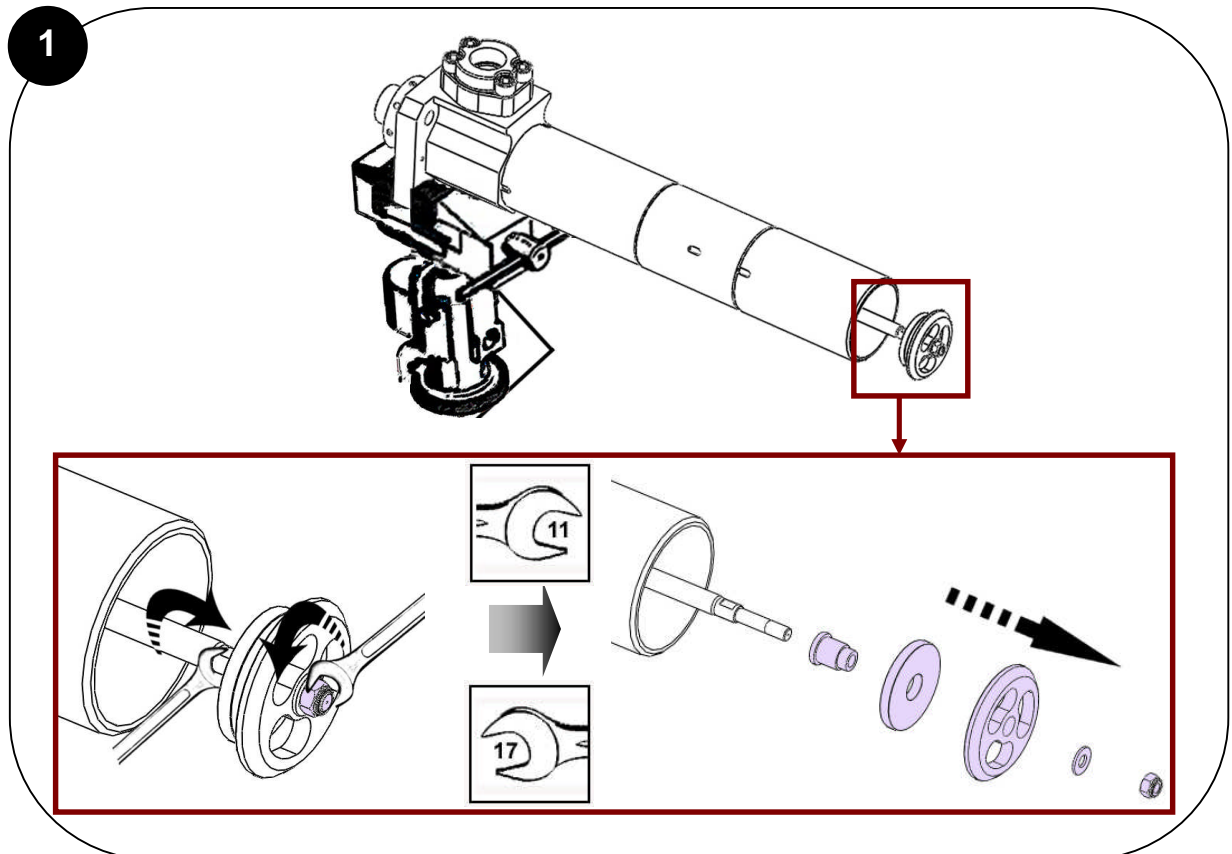

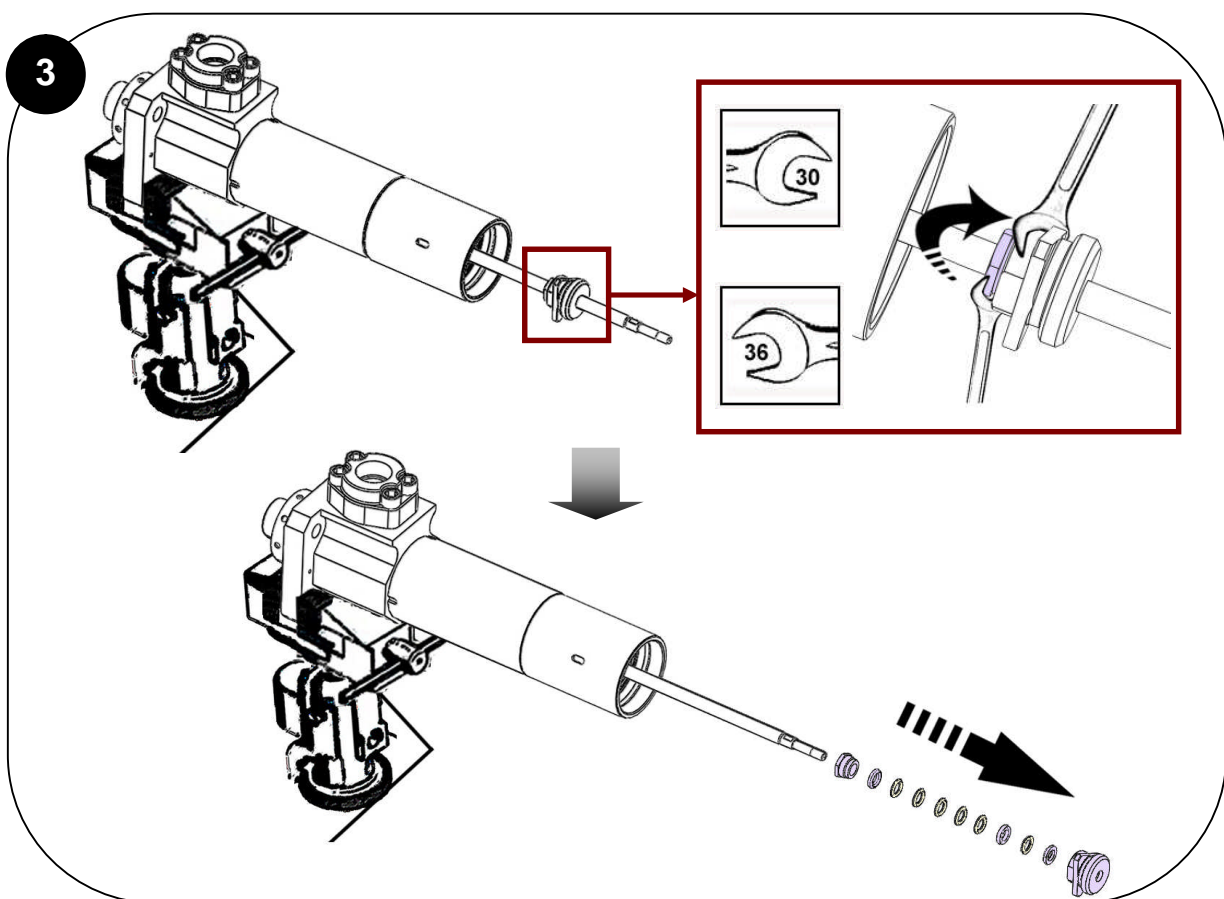
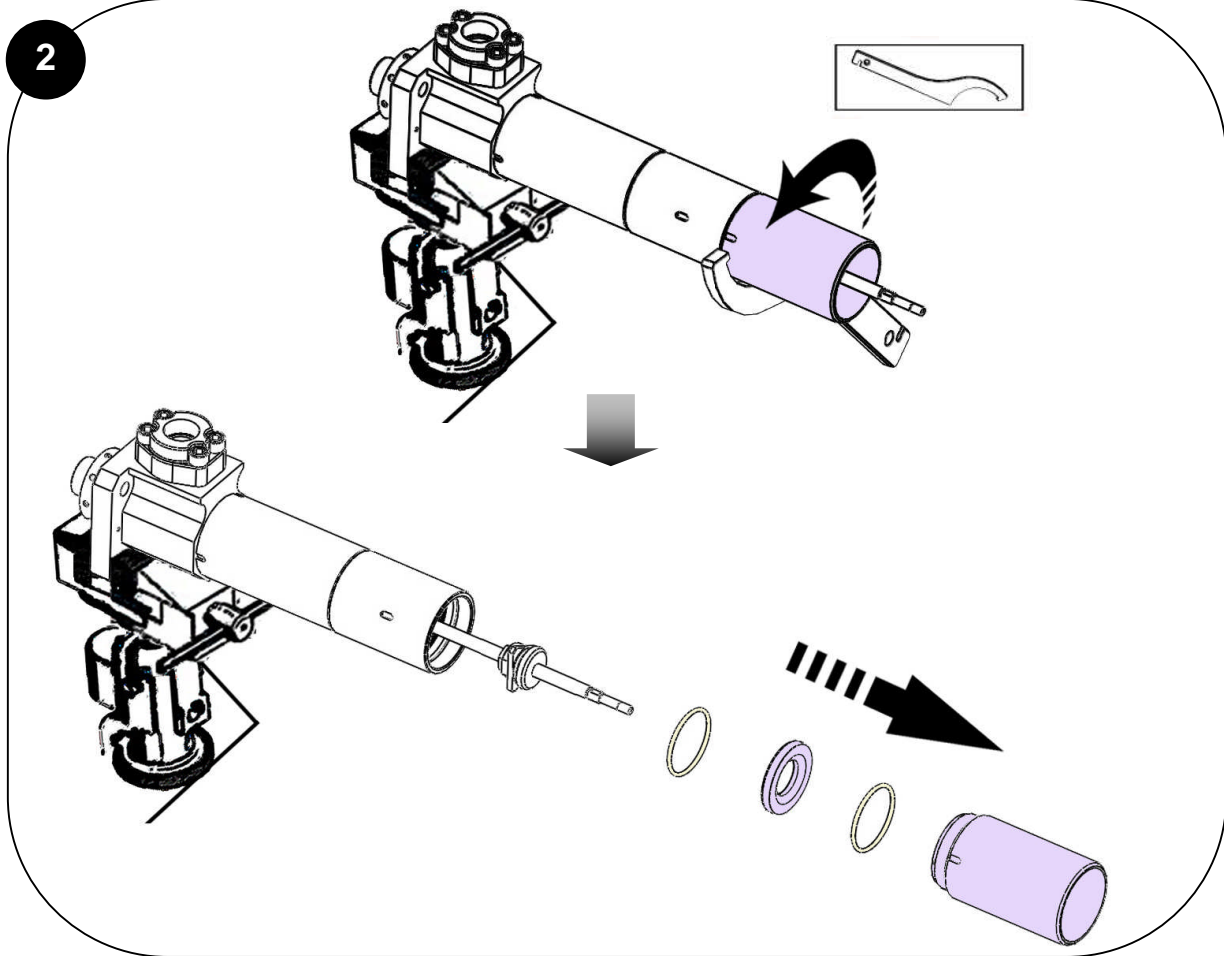



4

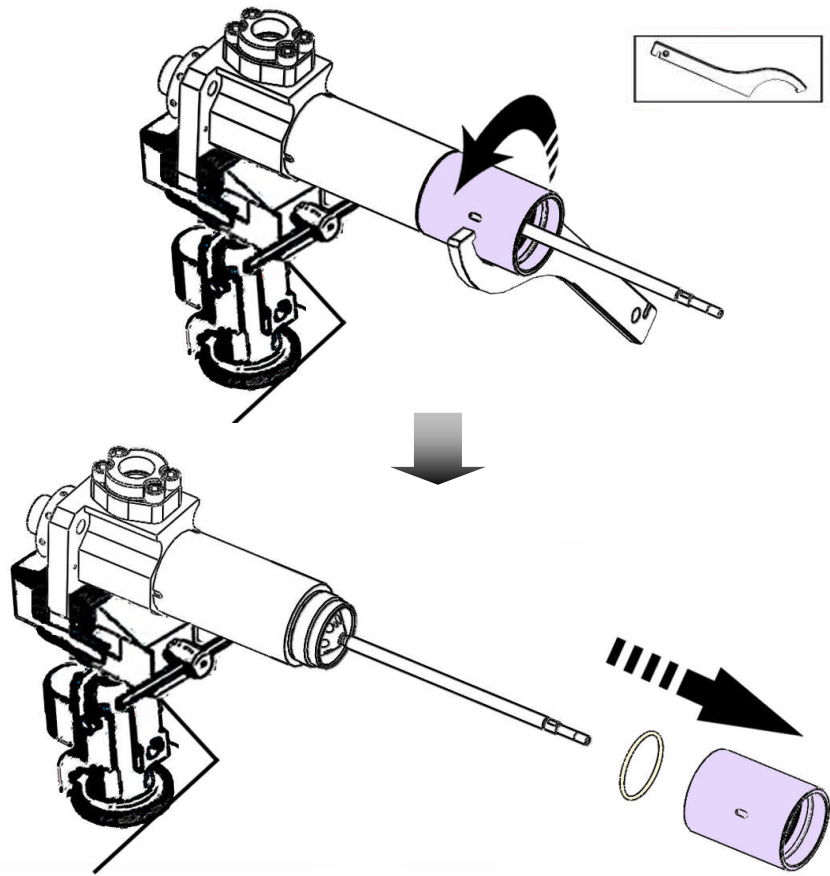

5

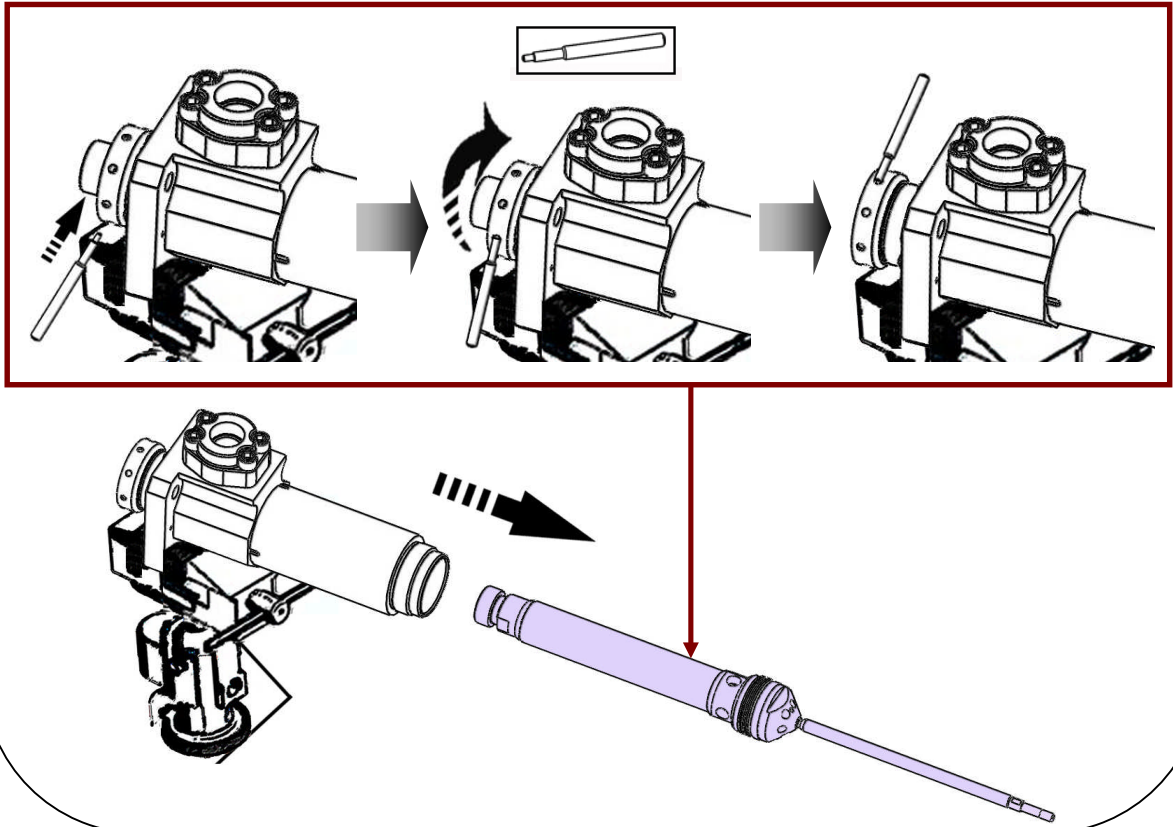

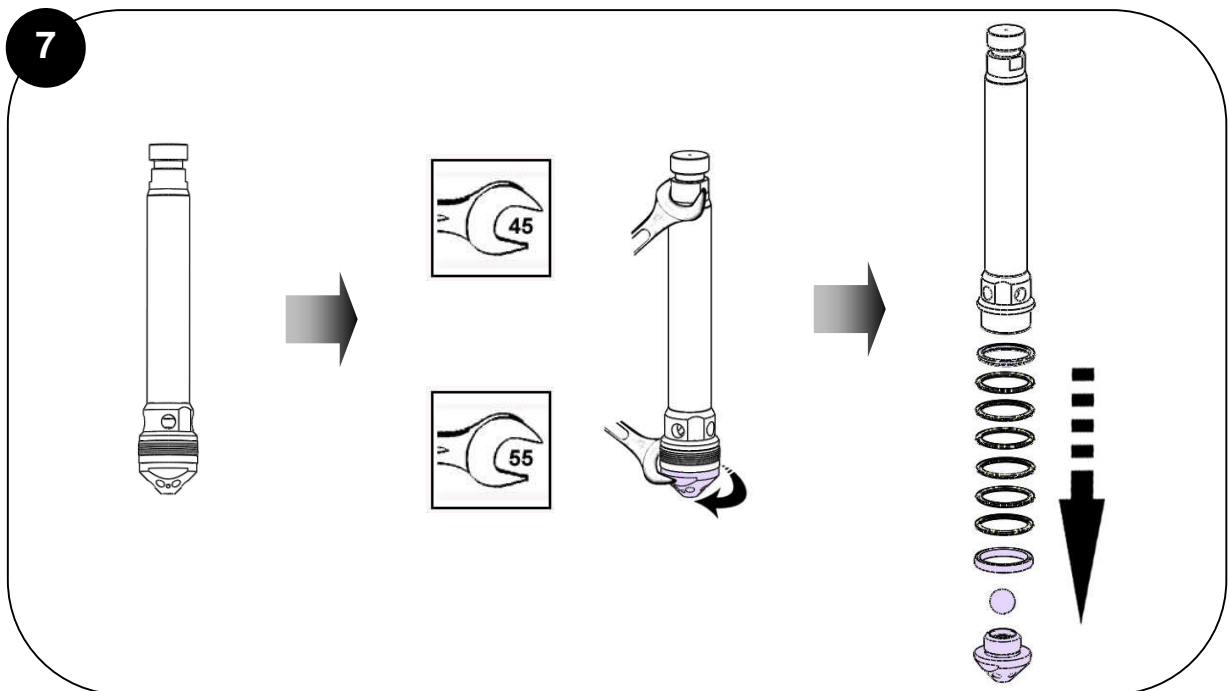
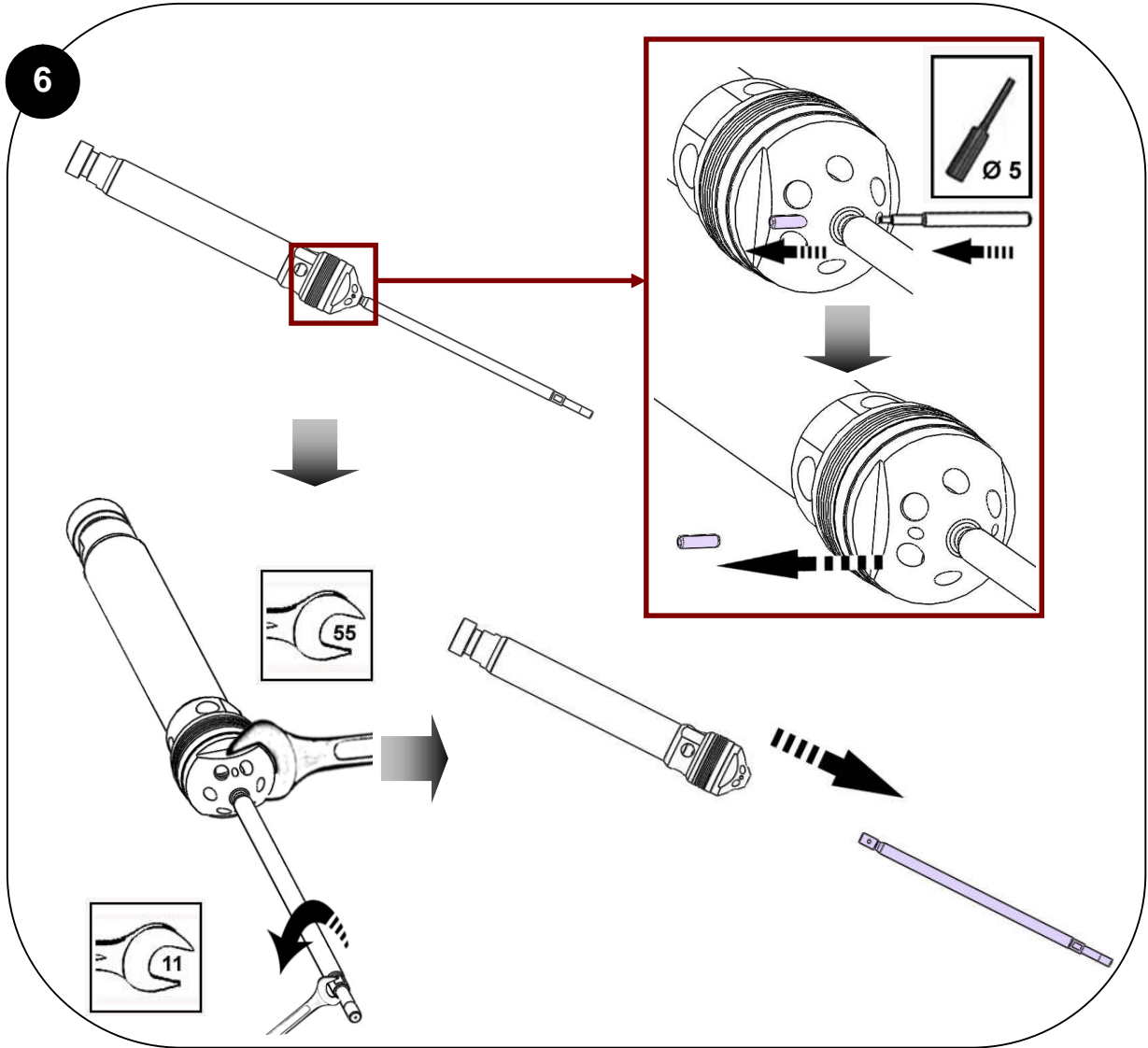

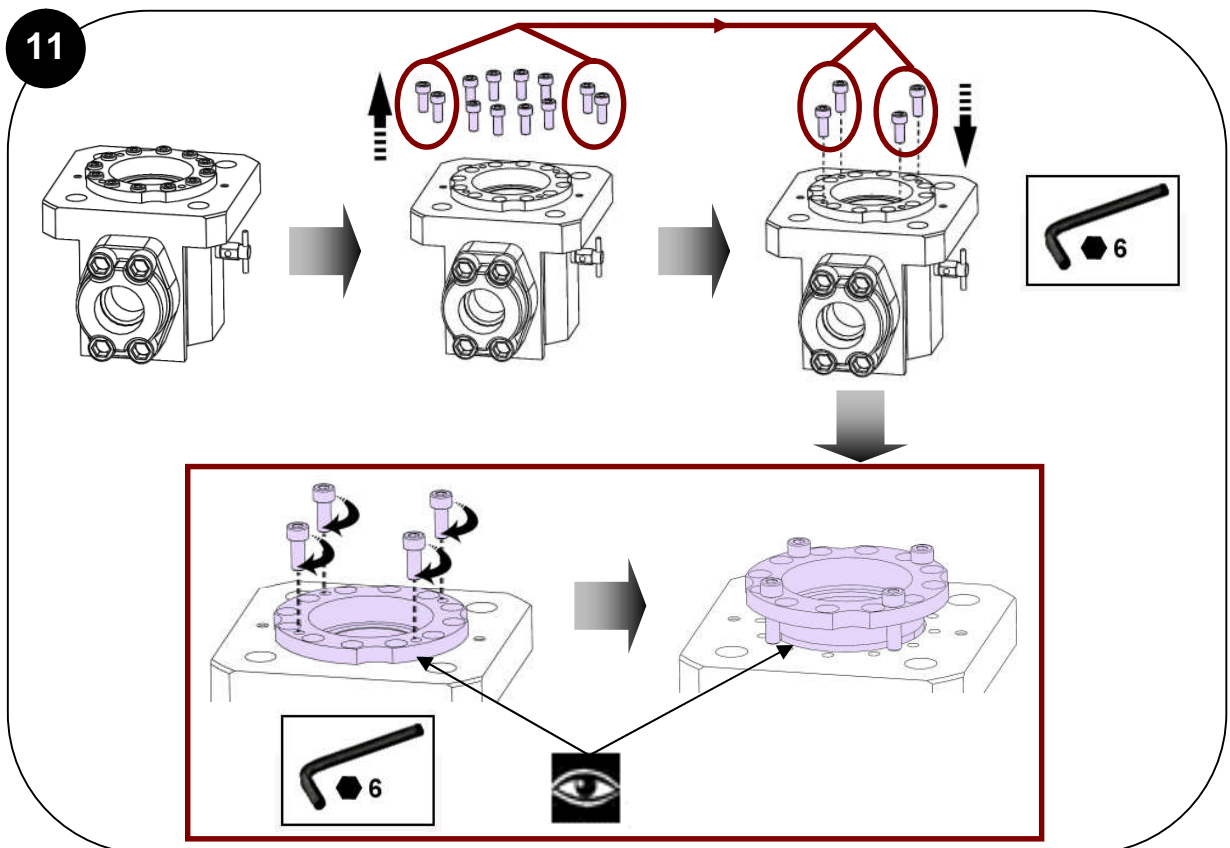
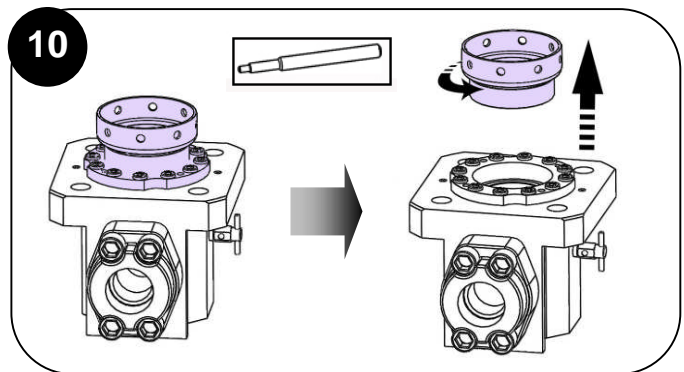
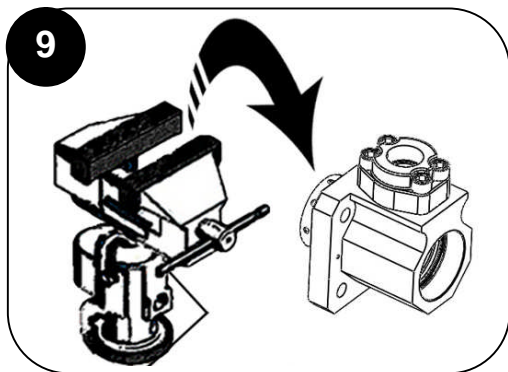
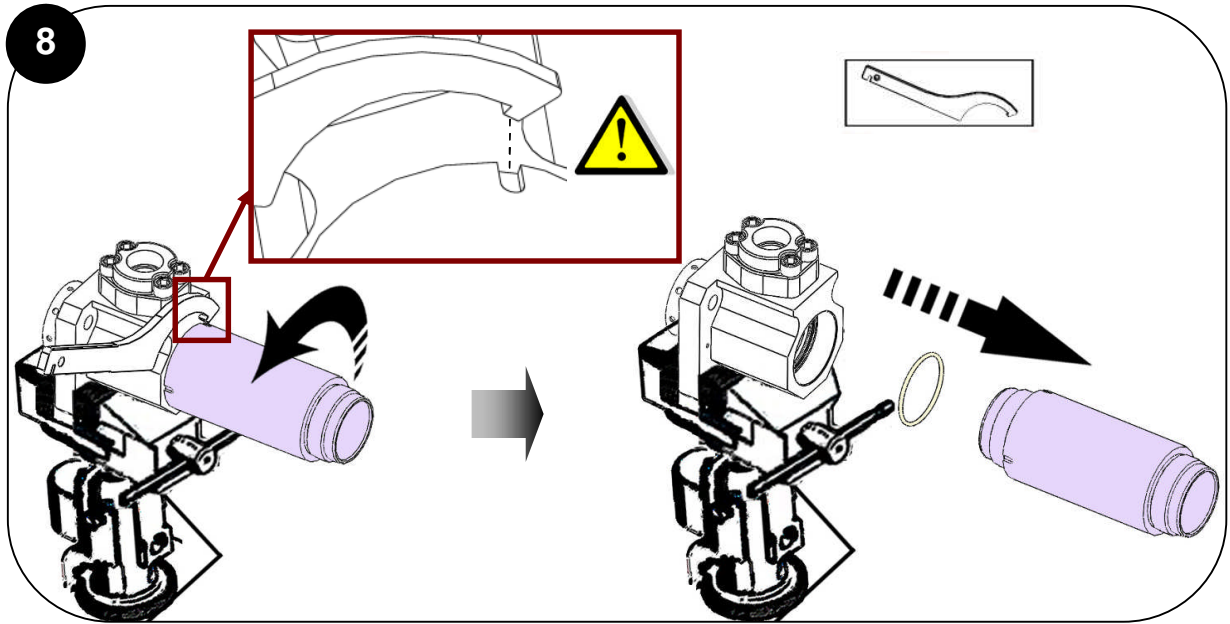

12

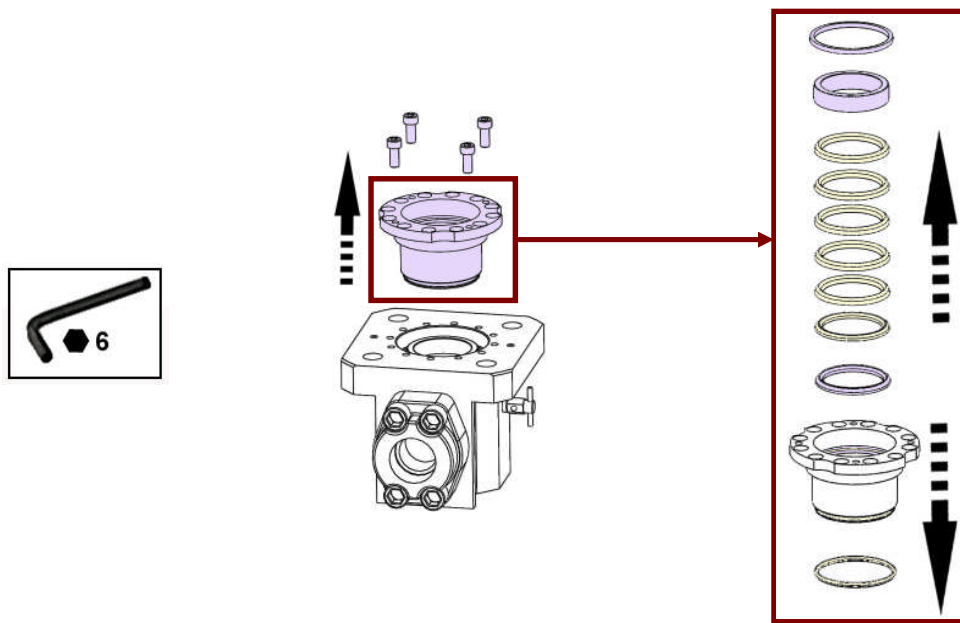

Des protecteurs (capot moteur, protecteur d'accouplement, carters,...) sont mis en place pour une utilisation sûre du matériel.

Le fabricant ne peut être tenu pour responsable en cas de dommages corporels ainsi que des pannes et / ou endommagement du matériel résultant de la destruction, de l'occultation ou du retrait total ou partiel des protecteurs.

/ Guards (air motor cover, coupling shields, housings ...) have been designed for safe use of the equipment. The manufacturer will not be held responsible for bodily injury or failure and / or damage to property due to removal or partial removal of the guards.

/ Schutzvorrichtungen an diesem Gerät, wie Motorhaube, Kupplungsschutz, Gehäuse, ggf. Erdungskabel, sowie weitere Vorrichtungen, wurden für eine sichere Benutzung dieses Gerätes entwickelt und angebracht. Der Hersteller lehnt jede Verantwortung für Körperschäden, Fehlfunktionen, Beschädigung der Geräte und jegliche andere Fehler ab, die durch die ganze oder teilweise Entfernung, Modifikation oder unsachgemäße Handhabung der Schutzvorrichtungen oder anderer Geräteteile entstehen.

/ Protectores (capó motor, protector de acoplamiento, cárteres,...) se colocan para una utilización segura del material. El fabricante no se hace responsable, en caso de daños personales, así como de las averías y / o daños del material, resultantes de la destrucción, la ocultación o la retirada total o parcial de los protectores.

13

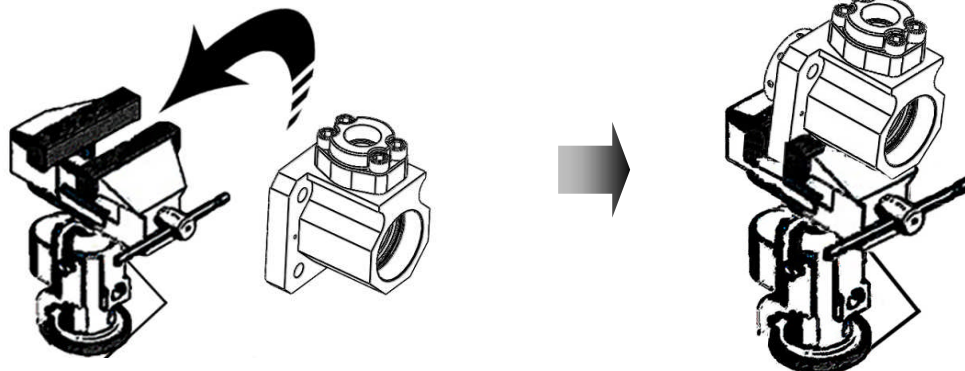

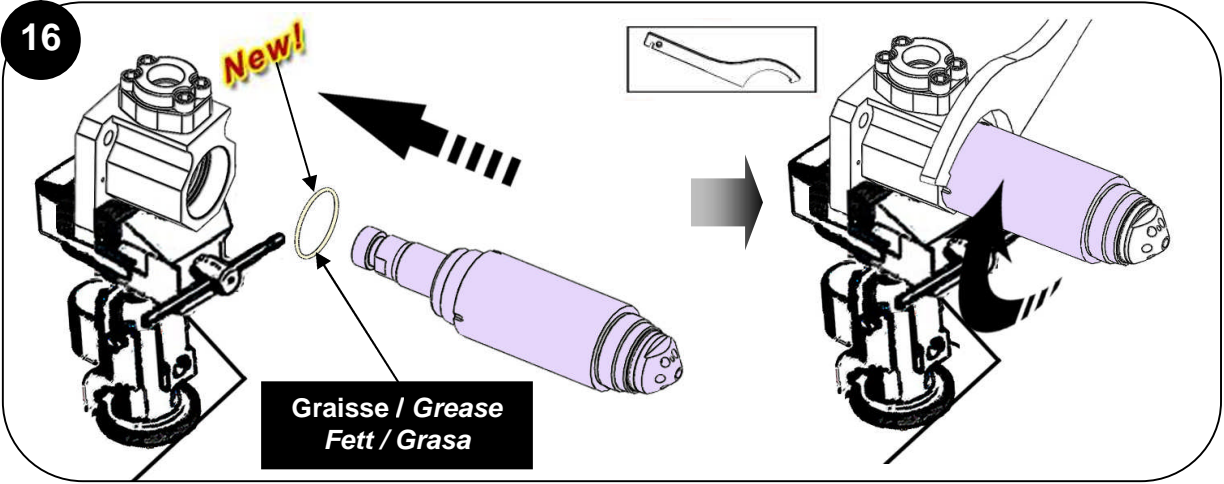
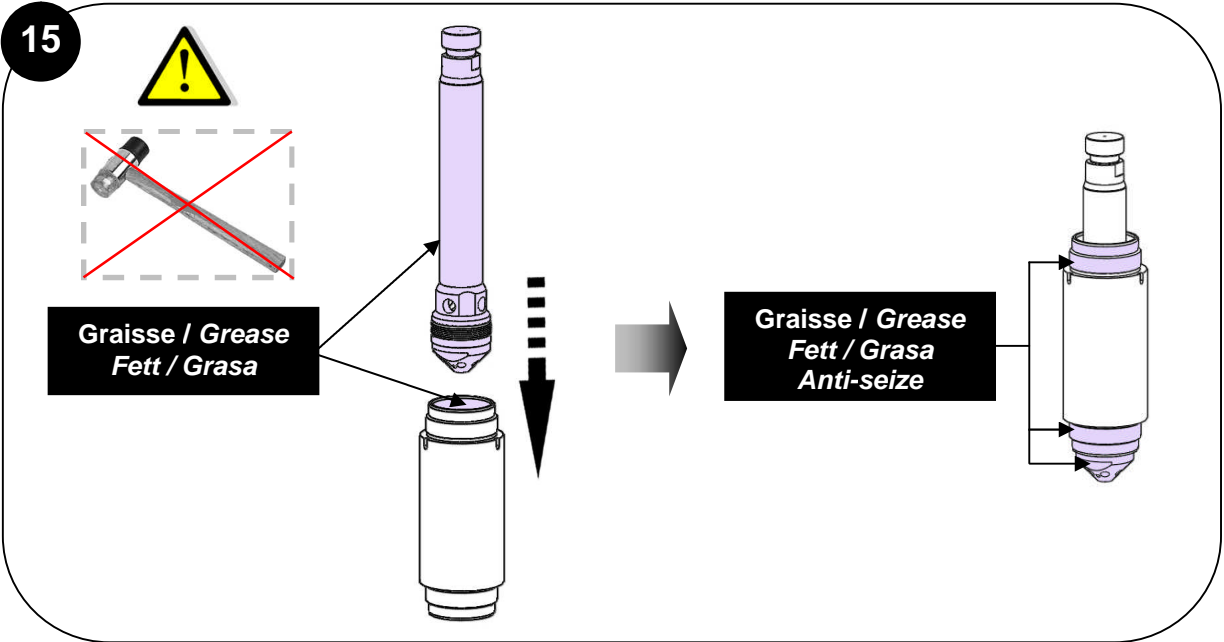
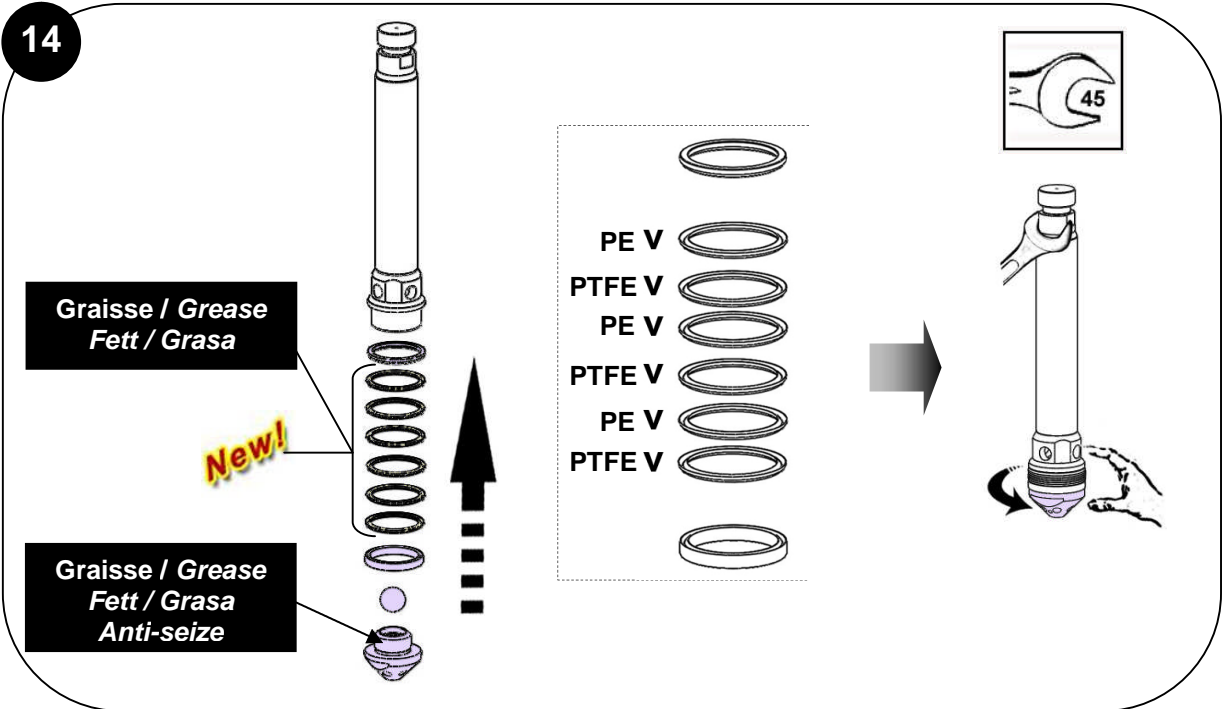

17

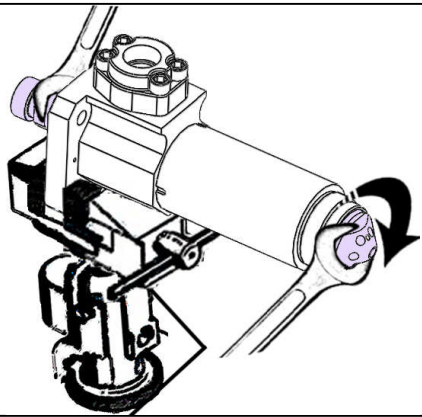

18

New!

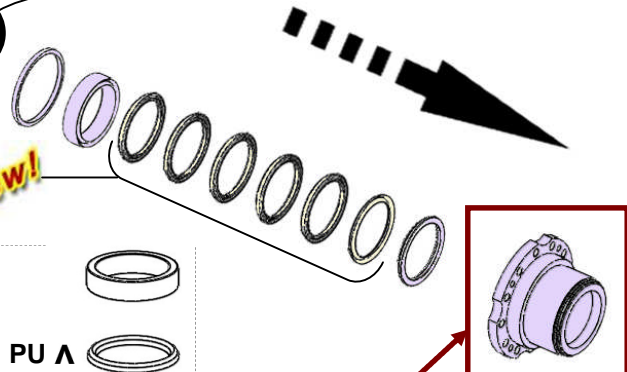

- PU Λ
- PU Λ
- PU Λ
- PU Λ
- PU Λ
- PE Λ

**Graisse / Grease  
Fett / Grasa**

New!

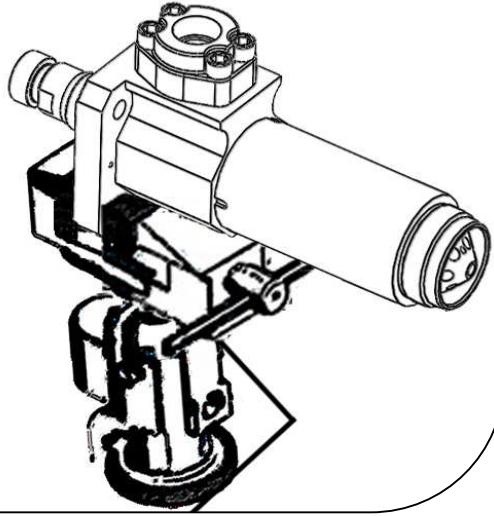

19

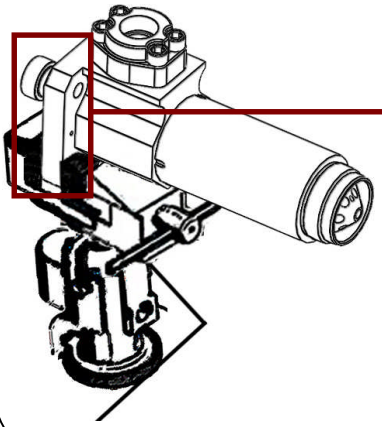

**6**

**20 N.m 14.75 ft/Lbs**

**Graisse / Grease  
Fett / Grasa**

20

Colle anaérobie tube étanche  
Medium strength - Anaerobic Adhesive  
Mittelfester Anaerober Kleber  
Cola para la estanqueidad  
(Loctite 577)

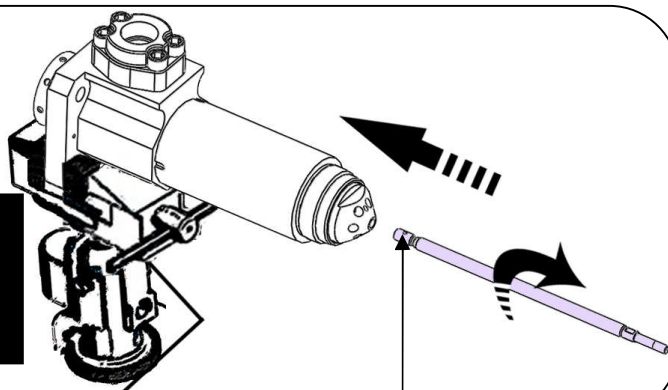

21

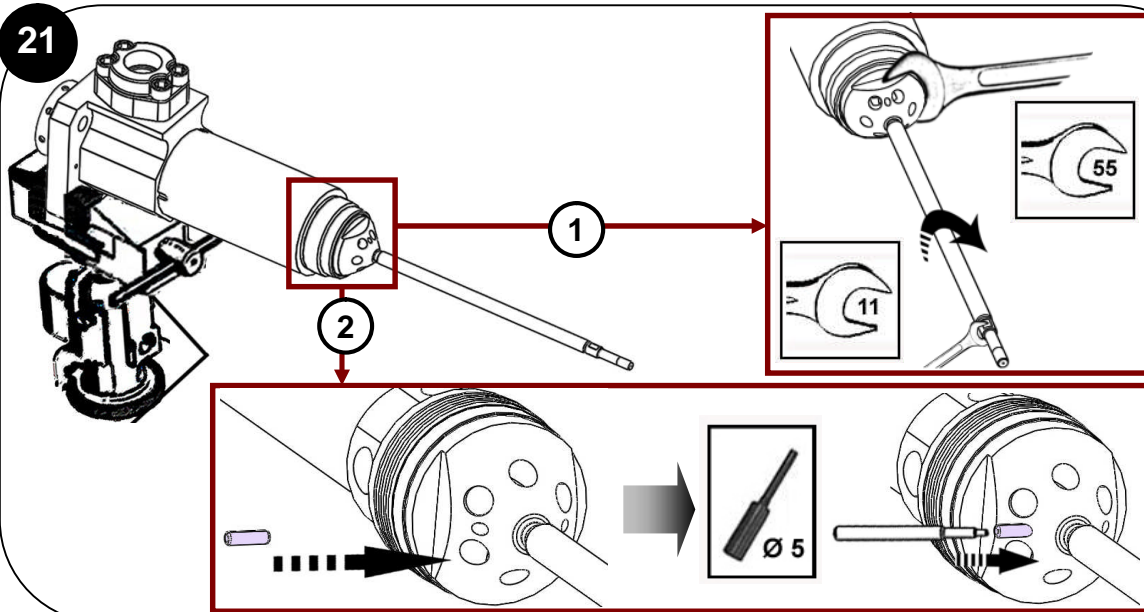

22

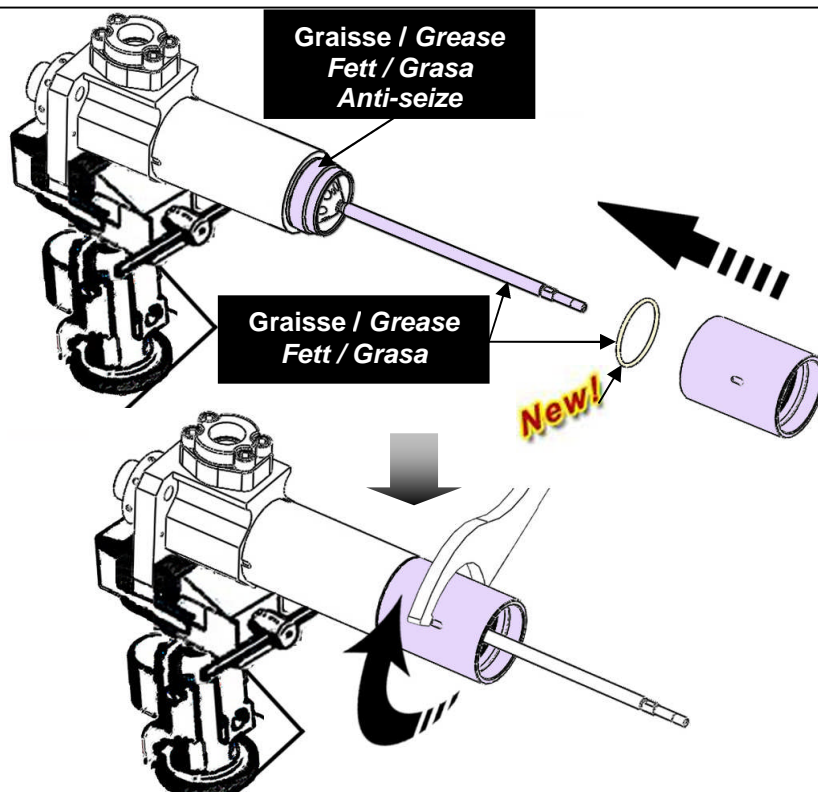

Colle anaérobie tube étanche  
 Medium strength - Anaerobic Adhesive  
 Mittelfester Anaerober Kleber  
 Cola para la estanqueidad  
 (Loctite 577)

Graisse / Grease  
 Fett / Grasa

New!

New!

- PE V
- PTFE V
- PE V
- PTFE V
- PE V
- PE Λ

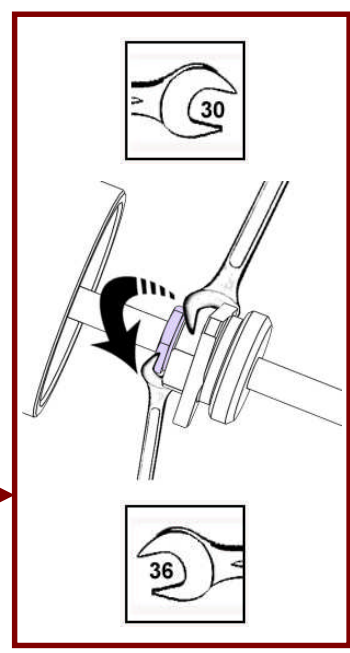
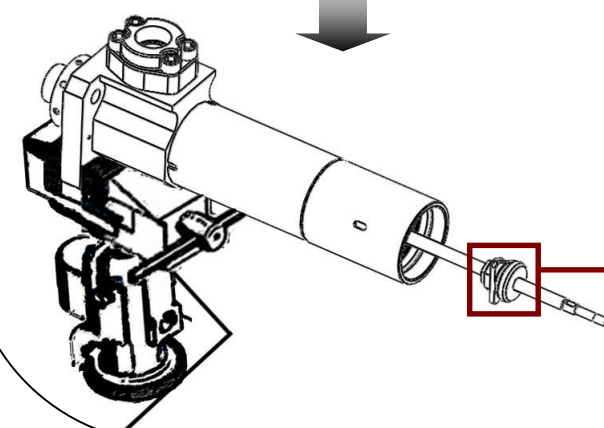
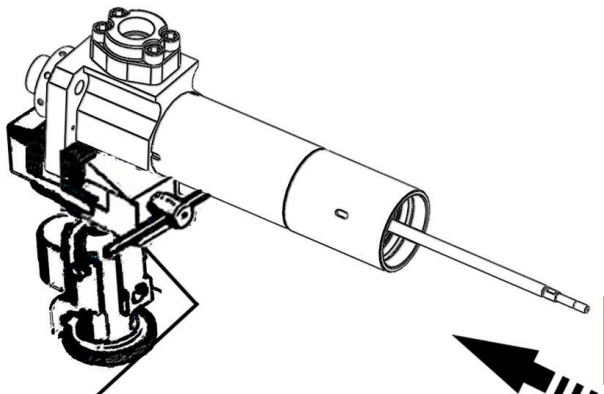



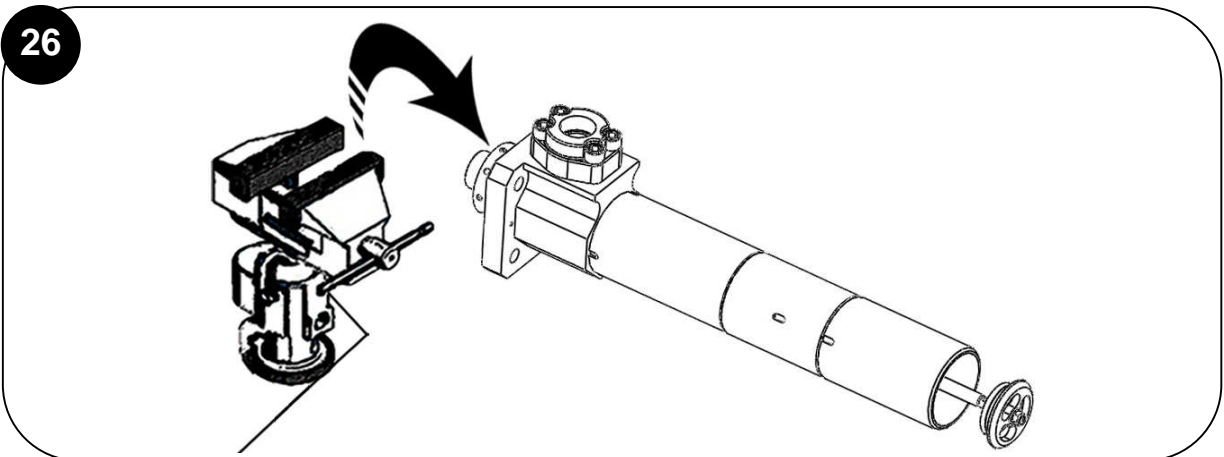
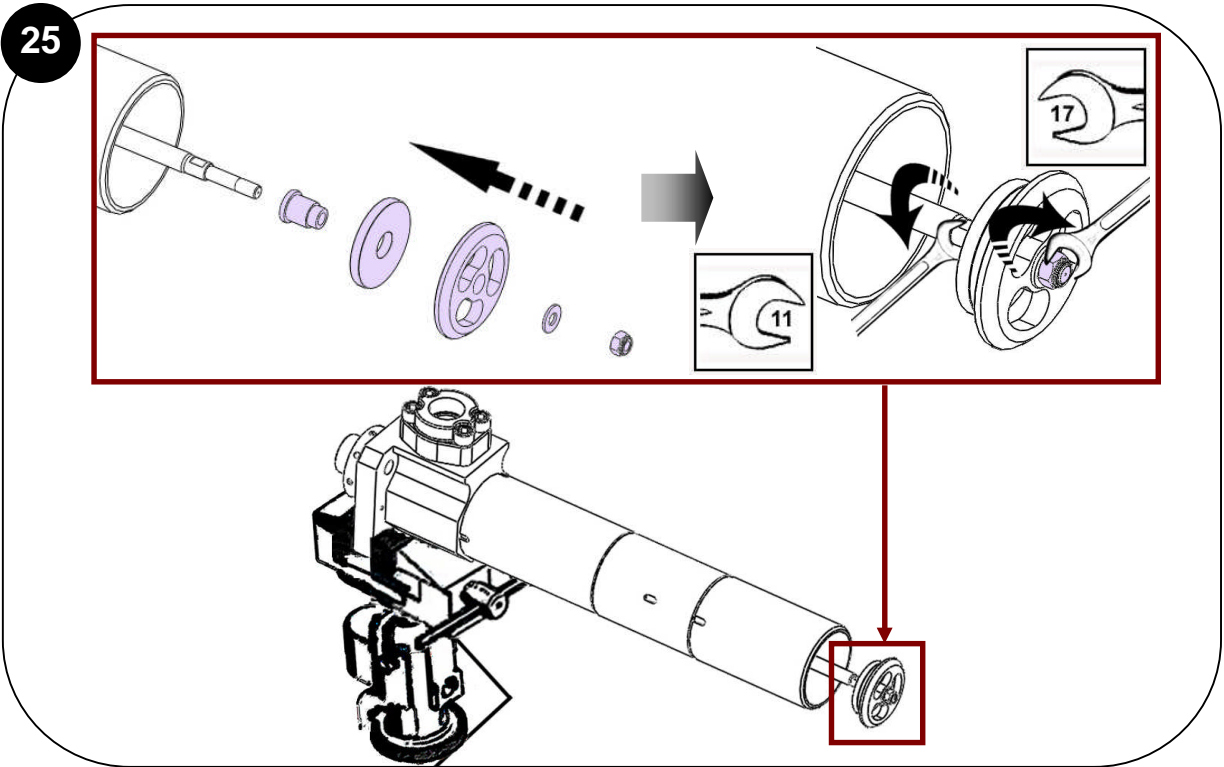
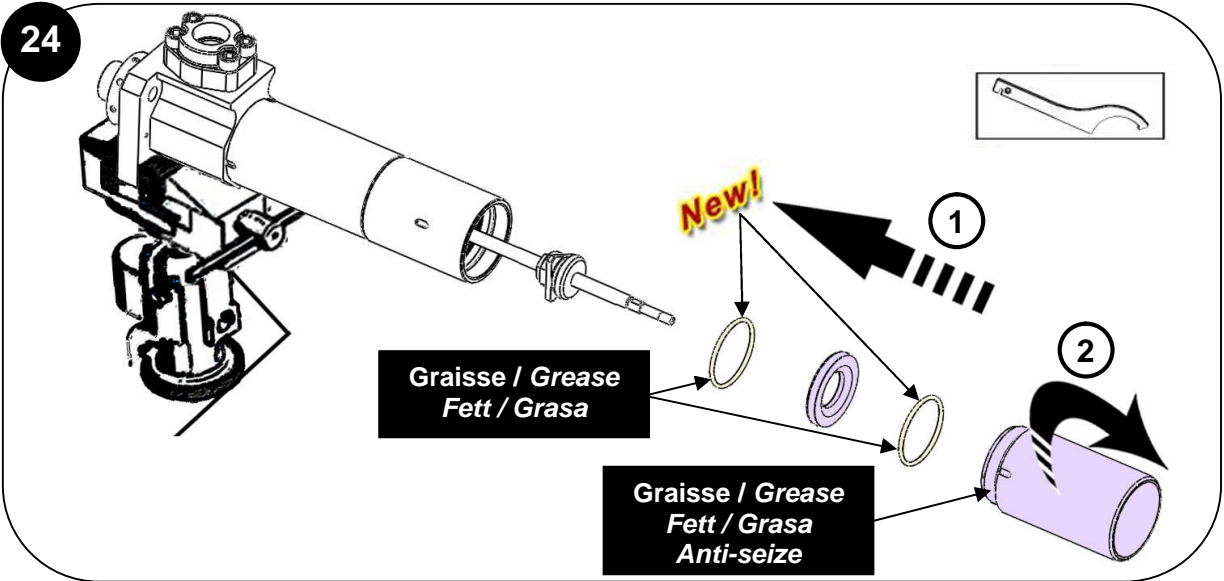

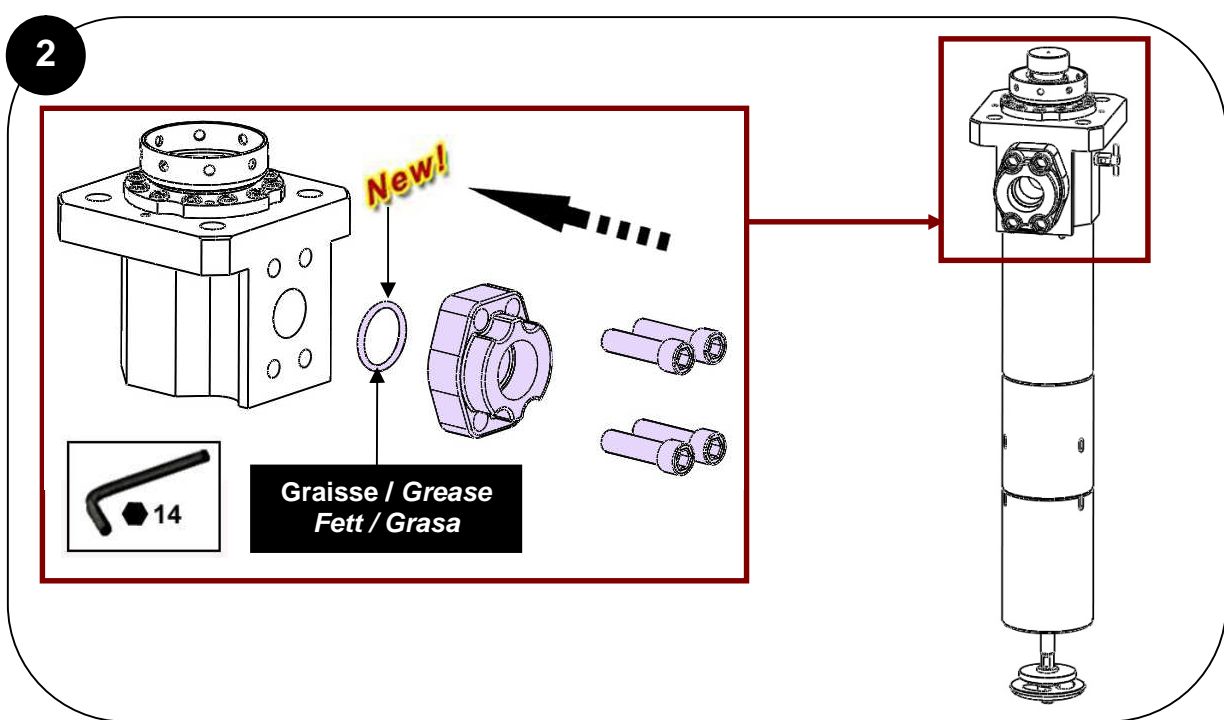
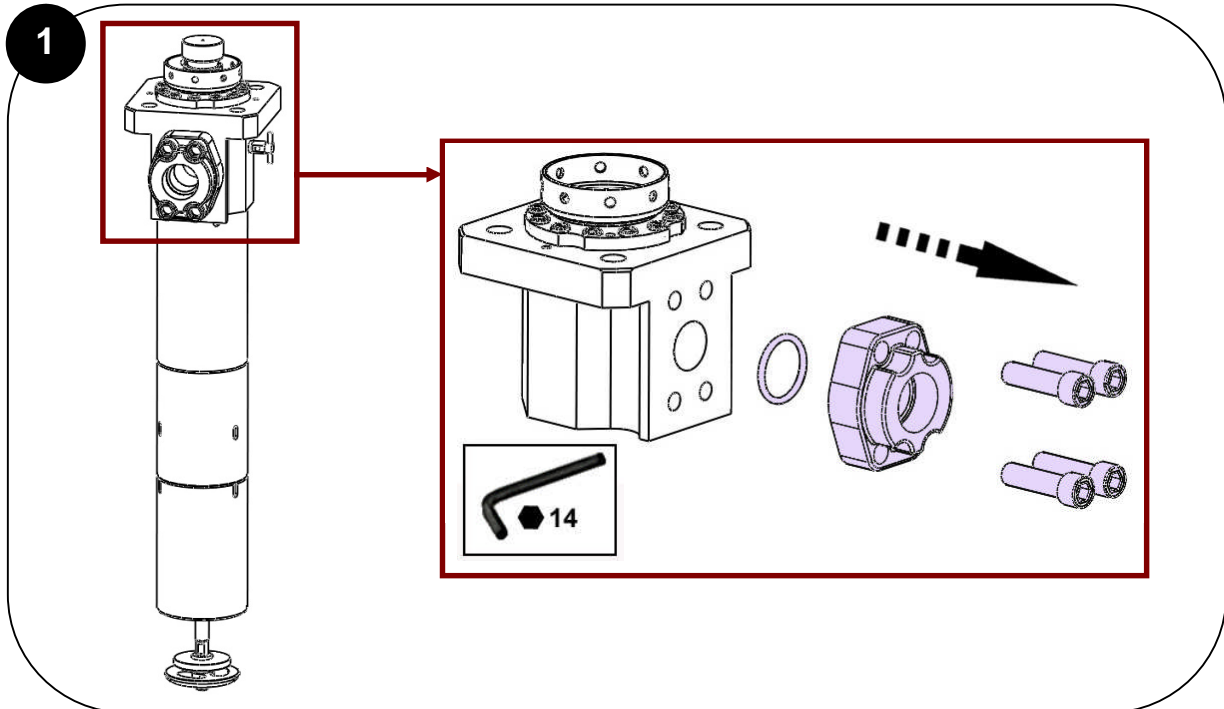
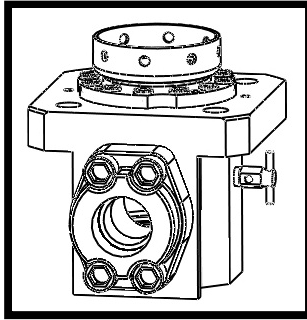

**POMPE A PALETTE / SHOVEL PUMP  
SCHÖPFKOLBENPUMPE / BOMBA CON PALETA  
THOR 60-C910-HD  
# 151 150 206**

**NOTICE ORIGINALE  
/ TRANSLATION OF THE ORIGINAL MANUAL  
/ ÜBERSETZUNG DER ORIGINAL BEDIENUNGSANLEITUNG  
/ TRADUCCIÓN DEL LIBRO ORIGINAL**

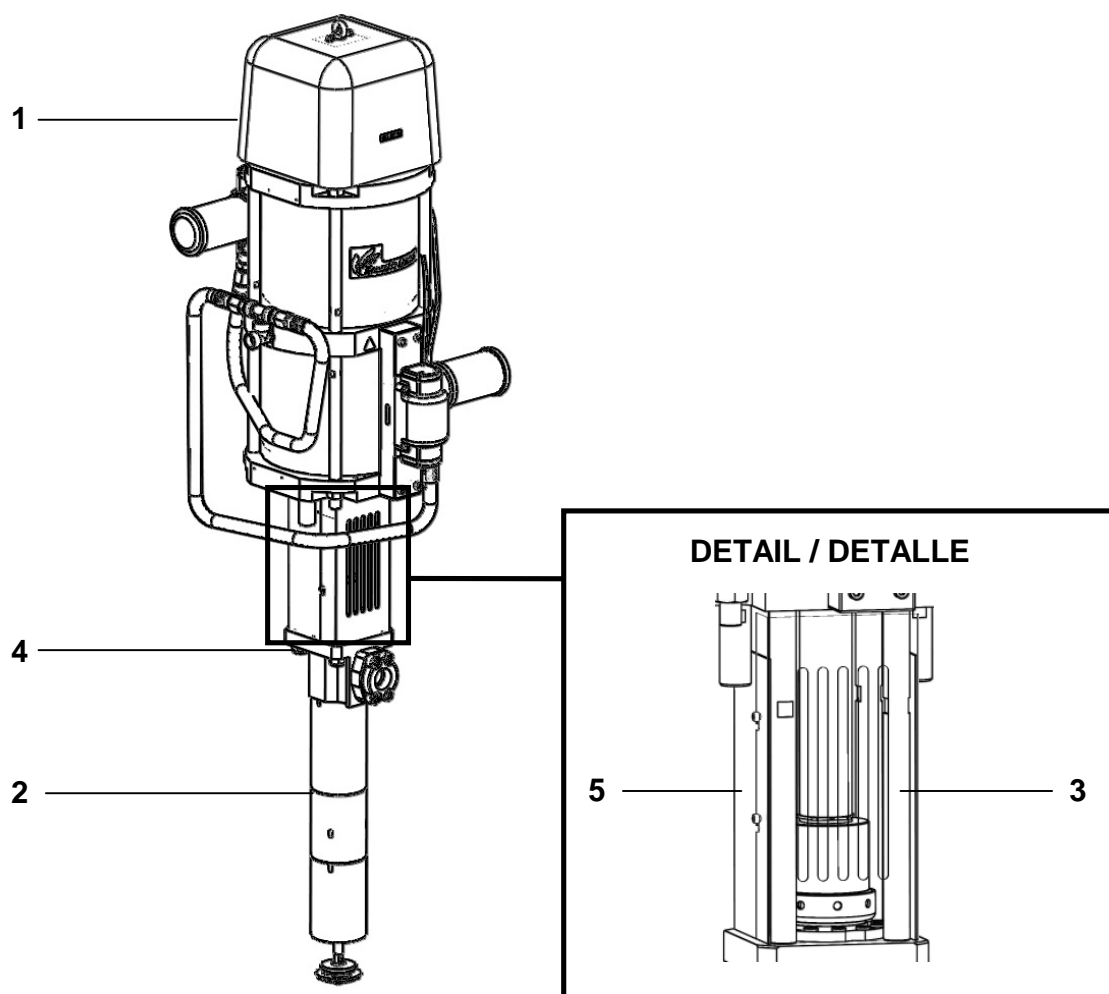

Ind	#	Désignation	Description	Bezeichnung	Denominación	Qté
*1	146 350 000	Moteur, type 9200-2 (voir Doc. 578.151.110)	Air motor, model 9200-2 (refer to Doc. 578.151.110)	Luftmotor, Modell 9200-2 (siehe Dok. 578.151.110)	Motor, tipo 9200-2 (consultar Doc. 578.151.110)	1
*2	144 251 106	Hydraulique à palette, type EOS C910-HD (voir Doc. 578.150.110)	Shovel fluid section, model EOS C910-HD (refer to Doc. 578.150.110)	Schöpfkolben Hydraulikteil Modell EOS C910-HD (siehe Dok. 578.150.110)	Hidraulica con paleta, tipo EOS C910-HD (consultar Doc. 578.150.110)	1
3	051 150 101	Tirant	Tie-rod	Stehbolzen	Tirante	4
4	88 338	Écrou M 20	Nut, M 20	Mutter M 20	Tuerca, M 20	4
5	151 150 110	Carter de protection	Protection housing	Schützgehäuse	Cárter de protección	1
6	210 946	Clé	Wrench	Schlüssel	Llave	1
-	149 990 020	Flacon de lubrifiant T (125 ml)	T Lubricant (125 ml / 4.4 oz)	Lösemittel "T" (125 ml)	Recipiente de lubricante T (125 ml)	1

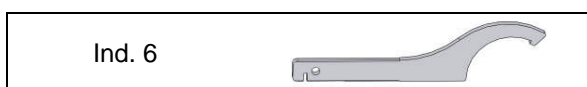

\* Pièces de maintenance préconisées.

\* Preceding the index number denotes a suggested spare part.

\* Bezeichnete Teile sind empfohlene Ersatzteile.

\* Piezas de mantenimiento preventivas.

N C : Non commercialisé.

N S : Denotes parts are not serviceable.

N S : Bezeichnete Teile gibt es nicht einzeln, sondern nur komplett.

N S : no suministrado.



**PIECES DE RECHANGE  
SPARE PARTS  
ERSATZTEILLISTE  
PIEZAS DE REPUESTO**

**MOTEUR A AIR / AIR MOTOR  
LUFTMOTOR / MOTOR DE AIRE**

**9200-2**

**# 146 350 000**

**NOTICE ORIGINALE  
/ TRANSLATION OF THE ORIGINAL MANUAL  
/ ÜBERSETZUNG DER ORIGINAL BETRIEBSANLEITUNG  
/ TRADUCCIÓN DEL LIBRO ORIGINAL**

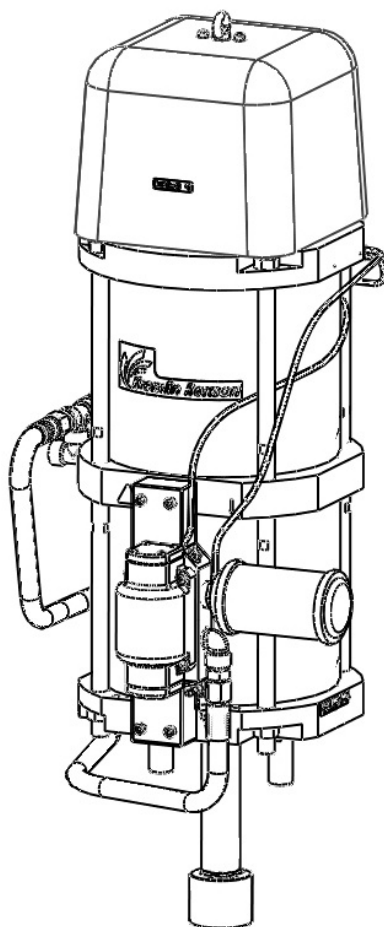

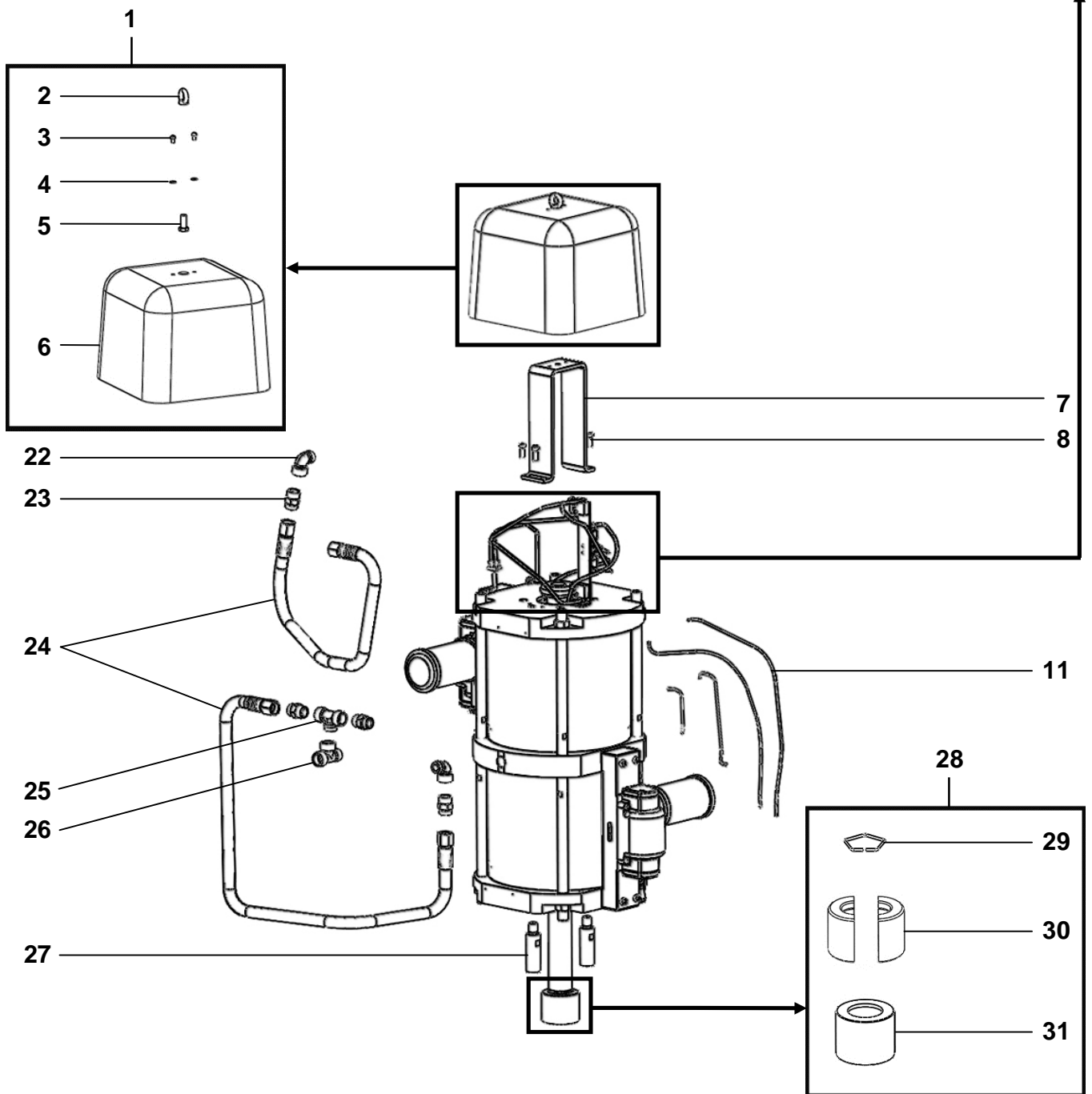
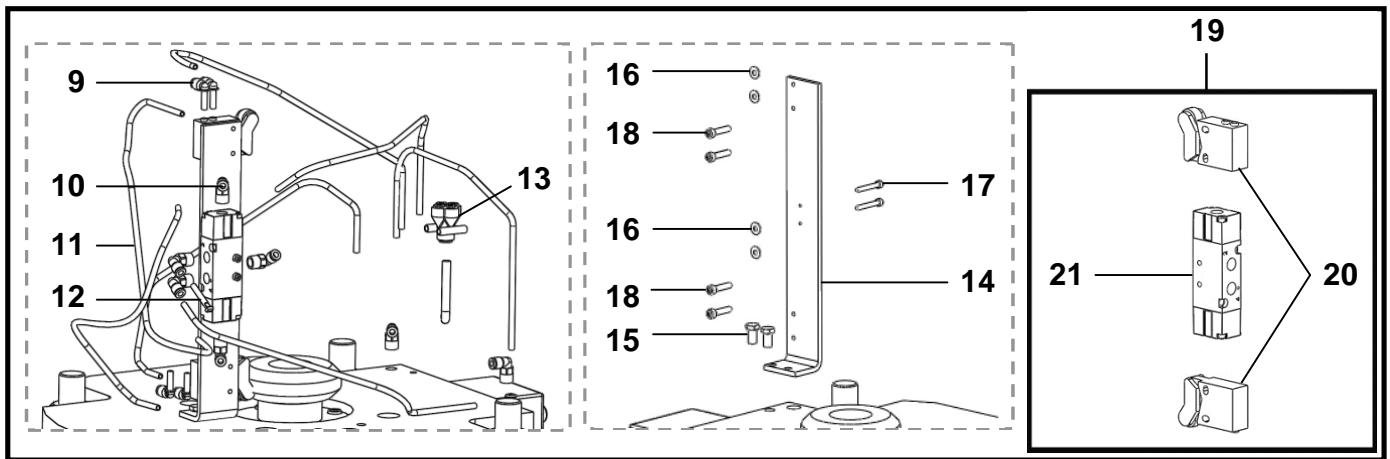

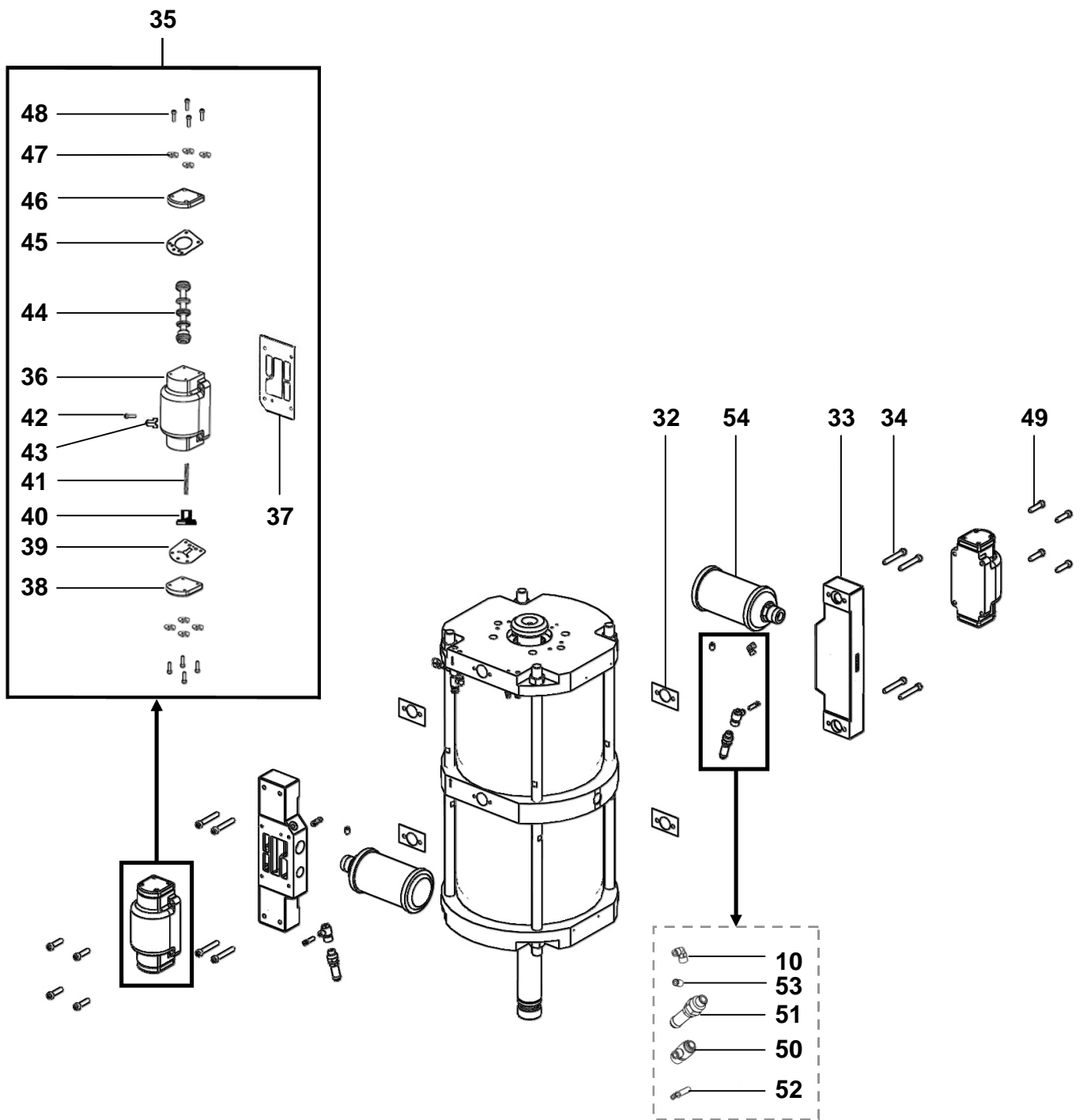

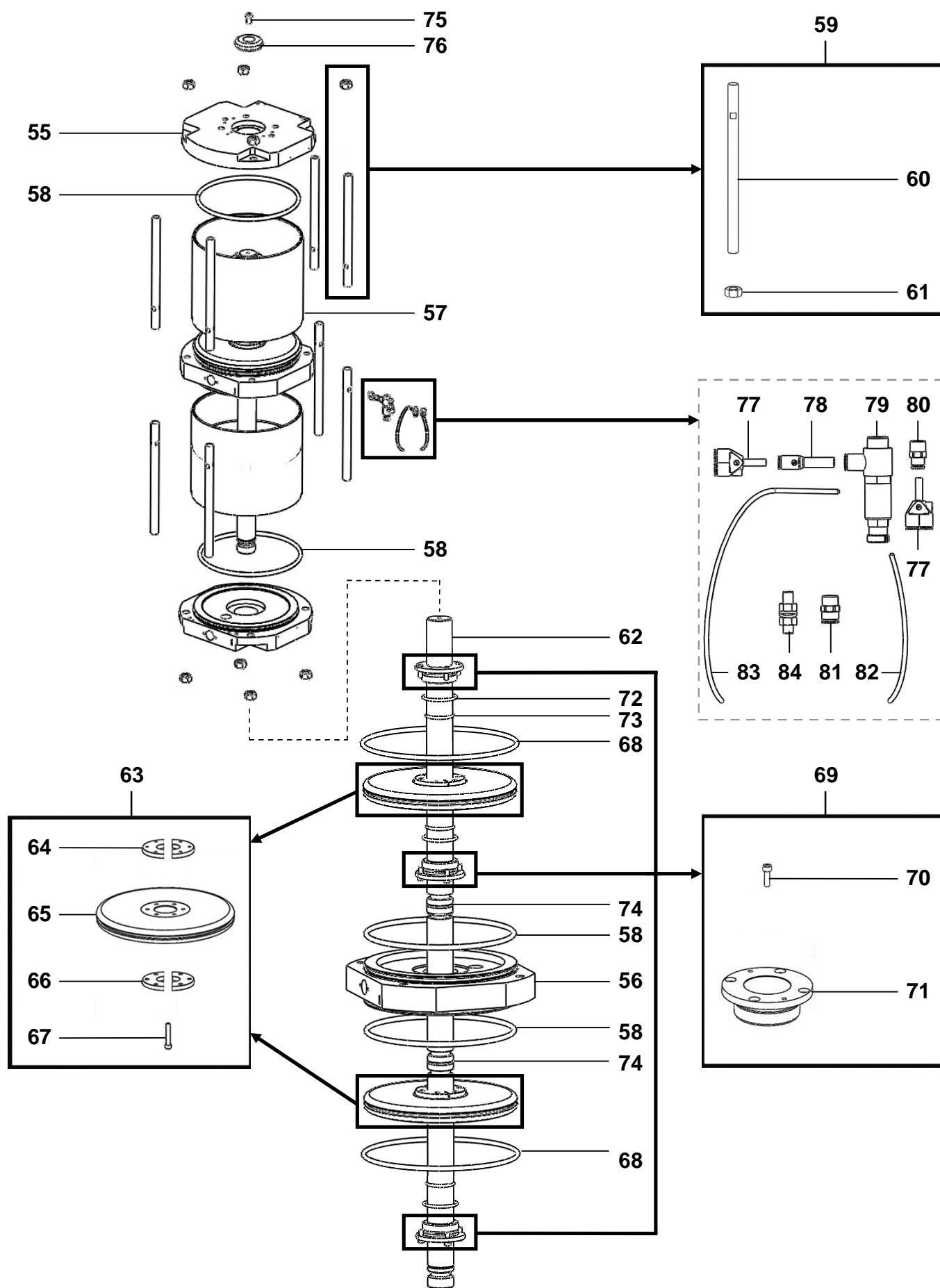



Ind	#	Désignation	Description	Bezeichnung	Denominación	Qté
*1	146 350 092	<b>Kit Capot et fixation</b>	<b>Cover and bracket kit</b>	<b>Haube mit Montage Kit</b>	<b>Kit de tapa y de fijación</b>	1
2	91 422	▪ Anneau de levage	▪ Hoisting ring	▪ Ringsschraube	▪ Anillo de sujeción	1
3	88 130	▪ Vis CHc M 6x10	▪ Screw, CHc M 6x10	▪ Schraube CHc M 6x10	▪ Tornillo, CHc M 6x10	2
4	963 040 016	▪ Rondelle MU 6	▪ Washer, MU 6	▪ Scheibe MU 6	▪ Arandela, MU 6	2
5	933 011 394	▪ Vis HM 12x30	▪ Screw, HM 12x30	▪ Schraube HM 12x30	▪ Tornillo, HM 12x30	1
6	209 352	▪ Capot	▪ Cover	▪ Haube	▪ Tapa	1
7	046 350 012	Etrier	U-Bolt	Halterung	Tirante	1
8	88 152	Vis CHc M 8x25	Screw, CHc M 8x25	Schraube CHc M 8x25	Tornillo, CHc M 8x25	4
9	905 120 983	Coude MF T 2x4	Elbow, MF T 2x4	Winkel Stecknippel A/I T 2x4	Codo, MH T 2x4	4
10	905 120 926	Coude M 1/8"	Elbow, M 1/8"	Winkelnippel AG 1/8"	Codo, M 1/8"	9
11	76 764	Tuyau PU 2,5x4 (longueur : 5 m)	Hose PU 2,5x4 (length: 5 m / 196.85")	Schlauch PU 2,5x4 (Länge: 5 m)	Tubería PU 2,5x4 (longitud : 5 m)	1
12	905 120 937	Bouchon pour tube	Tube plug	Verschlussstopfen für Stecknippel	Tapón de tubo	1
13	552 226	Raccord Y T 4x6	Fitting, Y T 4x6	Y-Anschluss, Schlauch 4x6	Racor, Y T 4x6	1
14	209 354	Équerre	Bracket	Winkel	Escuadra	1
15	933 011 170	Vis H M 6x12	Screw, H M 6x12	Schraube H M 6x12	Tornillo, H M 6x12	2
16	963 040 012	Rondelle MU 4	Washer, MU 4	Scheibe MU 4	Arandela, MU 4	4
17	932 151 326	Vis CHc M 3x25	Screw, CHc M 3x25	Schraube CHc M 3x25	Tornillo, CHc M 3x25	2
18	933 151 273	Vis CHc M 4x20	Screw, CHc M 4x20	Schraube CHc M 4x20	Tornillo, CHc M 4x20	4
*19	146 320 094	<b>Kit pneumatique</b>	<b>Pneumatic kit</b>	<b>Pneumatik Kit</b>	<b>Kit neumático</b>	1
20	151 800 002	▪ Capteur (x 2)	▪ Sensor (x 2)	▪ Meßfühler (2x)	▪ Captador (x 2)	1
21	91 424	▪ Distributeur 5/2 1/8"	▪ Distributor, 5/2 1/8"	▪ 5/2 Wege Ventil 1/8"	▪ Distribuidor, 5/2 1/8"	1
22	552 434	Coude MF 3/4"	Elbow, MF 3/4"	Winkelnippel AG 3/4" - IG 3/4"	Codo, MH 3/4"	2
23	050 102 634	Raccord M 3/4" NPS - M 3/4" G	Fitting, double male, 3/4" NPS - 3/4" G	Doppelnippel AG 3/4" NPS - 3/4" G	Racor, M 3/4" NPS - M 3/4" G	4
24	76 270	Tuyau 3/4" (longueur : 1,1 m)	Hose 3/4" (length: 1.1 m / 43.31")	3/4" Schlauch (Länge: 1,1 m)	Tubería (longitud : 1,1 m)	2
25	552 444	Raccord Té MFF 3/4"	Fitting, T MFF 3/4"	T-Anschluss AG/IG/IG 3/4"	Racor, Té MHH 3/4"	1
26	552 445	Raccord Té FFM 3/4"	Fitting, T FFM 3/4"	T-Anschluss IG/IG/AG 3/4"	Racor, Té HHM 3/4"	1
27	209 582	Pivot support	Support pin	Halterung Bolzen	Pivote soporte	2
*28	146 350 095	<b>Kit accouplement</b>	<b>Coupling kit</b>	<b>Kupplungs Kit</b>	<b>Kit de acoplamiento</b>	1
29	046 350 013	▪ Jonc	▪ Stop ring	▪ Sicherungsring	▪ Anillo de retención	1
30	046 350 014	▪ Coquille (2 parties)	▪ Bush (2 parts)	▪ Kupplung (2 Teile)	▪ Coquilla (2 partes)	1
31	046 350 015	▪ Bague de fermeture	▪ Closing ring	▪ Hülse	▪ Anillo de cierre	1

Ind	#	Désignation	Description	Bezeichnung	Denominación	Qté
*32	205 213	Joint d'embase	Base seal	Grundplattendichtung	Junta de base	4
33	209 365	Embase distributeur	Distributor base	Grundplatte für Ventil	Base distribuidor	2
34	88 908	Vis inox CHc M 8x60	Stainless screw, CHc M 8x60	Schraube aus Edelstahl CHc M 8x60	Tornillo de inox, CHc M 8x60	8
<b>*35</b>	<b>146 320 092</b>	<b>Distributeur 4/2 1"</b>	<b>Distributor, 4/2 1"</b>	<b>4/2 Wege Ventil 1"</b>	<b>Distribuidor, 4/2 1"</b>	<b>2</b>
36	NC / NS	▪ Corps du distributeur	▪ Distributor body	▪ Ventilkörper	▪ Cuerpo de distribuidor	2
*37	NC / NS	▪ Joint d'embase	▪ Base seal	▪ Grundplattendichtung	▪ Junta de base	2
38	NC / NS	▪ Couvercle, côté ressort	▪ Cover, spring side	▪ Deckel, Federseite	▪ Tapa, lado muelle	2
*39	NC / NS	▪ Joint latéral, côté ressort	▪ Side seal, spring side	▪ Seitliche Dichtung, Federseite	▪ Junta lateral, lado muelle	2
40	NC / NS	▪ Guide ressort	▪ Guide for spring	▪ Federführung	▪ Guía para muelle	2
*41	NC / NS	▪ Ressort	▪ Spring	▪ Feder	▪ Muelle	2
42	NC / NS	▪ Vis	▪ Screw	▪ Schraube	▪ Tornillo	2
43	NC / NS	▪ Joint	▪ Seal	▪ Dichtung	▪ Junta	2
*44	NC / NS	▪ Tiroir	▪ Valve	▪ Schieber	▪ Cajón	2
*45	NC / NS	▪ Joint latéral, côté air	▪ Side seal, air side	▪ Seitlich Dichtung, Luftseite	▪ Junta lateral, lado aire	2
46	NC / NS	▪ Couvercle, côté air	▪ Cover, air side	▪ Deckel, Luftseite	▪ Tapa, lado aire	2
47	NC / NS	▪ Rondelle	▪ Washer	▪ Scheibe	▪ Arandela	16
48	NC / NS	▪ Vis inox CHc M 5x16	▪ Stainless screw, CHc M 5x16	▪ Schraube aus Edelstahl CHc M 5x16	▪ Tornillo de inox, CHc M 5x16	16
49	88 514	Vis inox CHc M 8x35	Stainless screw, CHc M 8x35	Schraube aus Edelstahl CHc M 8x35	Tornillo de inox, CHc M 8x35	8
50	552 542	Raccord 1/4" G	Fitting, 1/4" G	Anschluss 1/4" G	Racor, 1/4" G	2
51	903 080 401	Soupape de sécurité	Safety valve	Sicherheitsventil	Válvula de seguridad	2
52	905 120 924	Bouchon pour tube	Tube plug	Verschlussstopfen für Stecknippel	Tapón de tubo	2
53	905 120 944	Piquage droit	Fitting	Abzweigstück, gerade	Piquaje recto	2
*54	146 350 017	Silencieux équipé (x 2)	Muffler assembly (x 2)	Schalldämpfer, montierte Einheit (2x)	Silenciador equipado (x 2)	1
55	046 350 001	Flasque d'extrémité	End flange	Endflansch	Brida de extremidad	2
56	046 350 002	Flasque intermédiaire	Intermediate flange	Zwischenflansch	Brida de intermediária	1
*57	146 350 091	Cylindre	Cylinder	Zylinder	Cilindro	2
*58	909 420 810	Joint de flasque	Flange seal	Flansch Dichtring	Junta de brida	4
<b>*59</b>	<b>146 350 011</b>	<b>Kit tirant</b>	<b>Rod kit</b>	<b>Stehbolzen Kit</b>	<b>Kit tirante</b>	<b>1</b>
60	046 350 011	▪ Tirant	▪ Tie-rod	▪ Stehbolzen	▪ Tirante	8
61	953 010 027	▪ Ecrou HM 20	▪ Nut, HM 20	▪ Mutter, HM 20	▪ Tuerca, HM 20	8
*62	146 350 006	Tige de piston	Piston rod	Kolbenstange	Eje de pistón	1

Ind	#	Désignation	Description	Bezeichnung	Denominación	Qté
*63	146 350 094	<b>Kit piston</b>	<b>Piston kit</b>	<b>Kolben Kit</b>	<b>Kit de pistón</b>	1
64	046 350 008	▪ Contre-bride (2 parties)	▪ Adapter (2 parts)	▪ Flansch Halbschalen (2 Teile)	▪ Contra brida (2 partes)	2
65	046 350 007	▪ Piston	▪ Piston	▪ Luftmotor-Kolben	▪ Pistón	2
66	046 350 009	▪ Bride d'arrêt (2 parties)	▪ Stop flange (2 parts)	▪ Gegenflansch Halbschalen (2 Teile)	▪ Brida de ajuste (2 partes)	2
67	88 166	▪ Vis CHc M 8x50	▪ Screw, CHc M 8x50	▪ Schraube CHc M 8x50	▪ Tornillo, CHc M 8x50	12
*68	81 081	Joint de piston	Piston seal	Kolbendichtung	Junta de pistón	2
*69	146 350 096	<b>Kit palier</b>	<b>Bearing kit</b>	<b>Lager Kit</b>	<b>Kit de palier</b>	1
70	88 134	▪ Vis CHc M 6x20	▪ Screw, CHc M 6x20	▪ Schraube CHc M 6x20	▪ Tornillo, CHc M 6x20	12
71	046 350 010	▪ Palier	▪ Bearing	▪ Lager	▪ Palier	3
*72	84 188	Joint FKM	Seal, FKM	Dichtung aus FKM	Junta FKM	3
*73	909 420 280	Joint FKM	Seal, FKM	Dichtung aus FKM	Junta FKM	3
*74	909 420 109	Joint	Seal	Dichtring	Junta	2
75	88 203	Vis CHc M 10x20	Screw, CHc M 10x20	Schraube CHc M 10x20	Tornillo, CHc M 10x20	1
76	046 350 016	Came	Cam	Nocken	Leva	1
82	552 447	Raccord droit 1/4"	Straight fitting, 1/4"	Gerader Nippel 1/4"	Racor recto, 1/4"	1
77	905 120 925	Raccord Y MF T 2,7x4	Fitting, Y MF T 2,7x4	Y-Steckanschluss A/I Schlauch 2,7x4	Racor, Y MH T 2,7x4	2
78	905 120 928	Raccord T 4x6 - 2,7x4	Fitting, T 4x6 - 2,7x4	Reduzierung 4x6 - 2,7x4	Racor, T 4x6 - 2,7x4	1
79	903 130 508	Réducteur de pression 1/4" G	Pressure reducer 1/4" G	Druckreduziernippel 1/4" G	Reductor de presión 1/4" G	1
80	905 120 907	Raccord droit 1/8"	Straight fitting, 1/8"	Gerader Nippel 1/8"	Racor recto, 1/8"	1
81	905 124 901	Raccord droit 1/8"	Straight fitting, 1/8"	Gerader Nippel 1/8"	Racor recto, 1/8"	1
82	76 607	Tube PU 4x6 (longueur : 2 m)	Tube PU 4x6 (length: 2 m / 78.74")	Schlauch (Länge: 2 m)	Tubo (longitud : 2 m)	1
83	76 519	Câble de mise à la terre	Cable ground	Erdungskagel	Cable de puesta a tierra	1
84	055 680 006	Borne de mise à la terre équipée	Earth terminal assembly	Erdungsanschluss montiert	Toma de tierra equipada	1
*	146 350 098	<b>Pochette de joints moteur(ind. 32 (x4), 58 (x4), 68 (x2), 72 (x3), 73 (x3), 74 (x2))</b>	<b>Seal kit air motor (ind. 32 (x4), 58 (x4), 68 (x2), 72 (x3), 73 (x3), 74 (x2))</b>	<b>Dichtungssatz des Luftmotors (beinhaltet Pos. 32 (4x), 58 (4x), 68 (2x), 72 (3x), 73 (3x), 74 (2x))</b>	<b>Bolsa de juntas motor (índ. 32 (x4), 58 (x4), 68 (x2), 72 (x3), 73 (x3), 74 (x2))</b>	1
*	146 320 093	<b>Pochette de maintenance distributeur 4/2 1" (ind. 37, 39, 41, 44, 45)</b>	<b>Servicing kit distributor 4/2 1" (ind. 37, 39, 41, 44, 45)</b>	<b>Reparatursatz des 4/2 Wege Ventils 1" (beinhaltet Pos. 37, 39, 41, 44, 45)</b>	<b>Bolsa de reparación del distribuidor 4/2 1" (ind. 37, 39, 41, 44, 45)</b>	1

\* Pièces de maintenance préconisées.

\* Preceding the index number denotes a suggested spare part.

\* Bezeichnete Teile sind empfohlene Ersatzteile.

\* Piezas de mantenimiento preventivas.

N C : Non commercialisé.

N S : Denotes parts are not serviceable.

N S : Bezeichnete Teile gibt es nicht einzeln, sondern nur komplett.

N S : no suministrado.



**PIECES DE RECHANGE  
SPARE PARTS  
ERSATZTEILLISTE  
PIEZAS DE REPUESTO**

**HYDRAULIQUE A PALETTE / SHOVEL FLUID SECTION  
SCHÖPFKOLBEN HYDRAULIKTEIL / HIDRÁULICA CON PALETA**

**THOR C910-HD**

**# 144 251 106**

**NOTICE ORIGINALE  
/ TRANSLATION OF THE ORIGINAL MANUAL  
/ ÜBERSETZUNG DER ORIGINAL BETRIEBSANLEITUNG  
/ TRADUCCIÓN DEL LIBRO ORIGINAL**

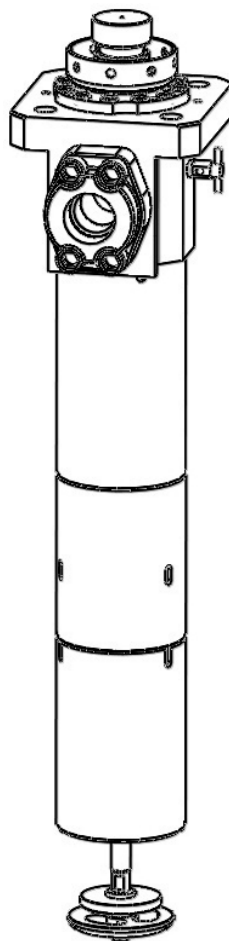

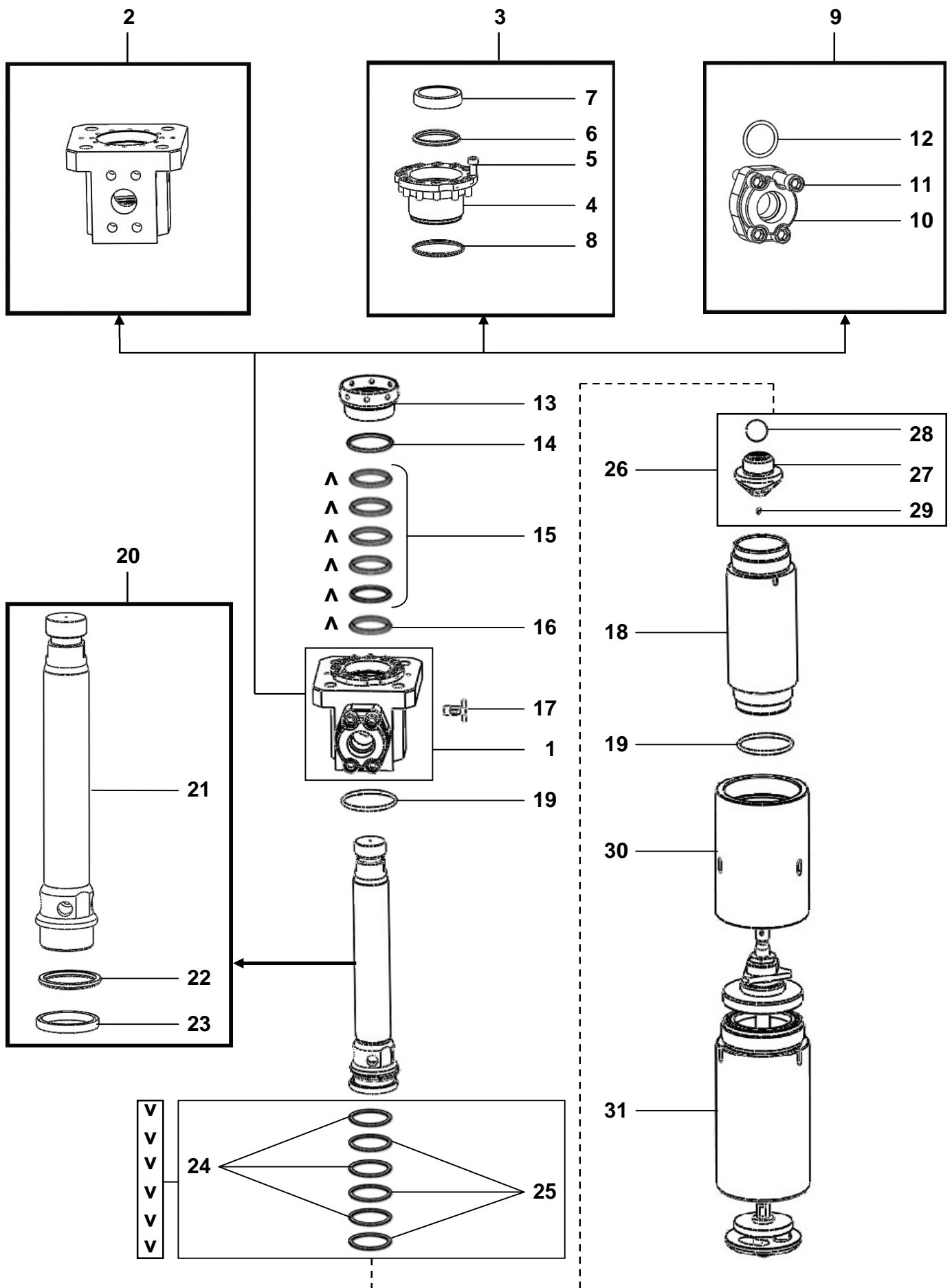

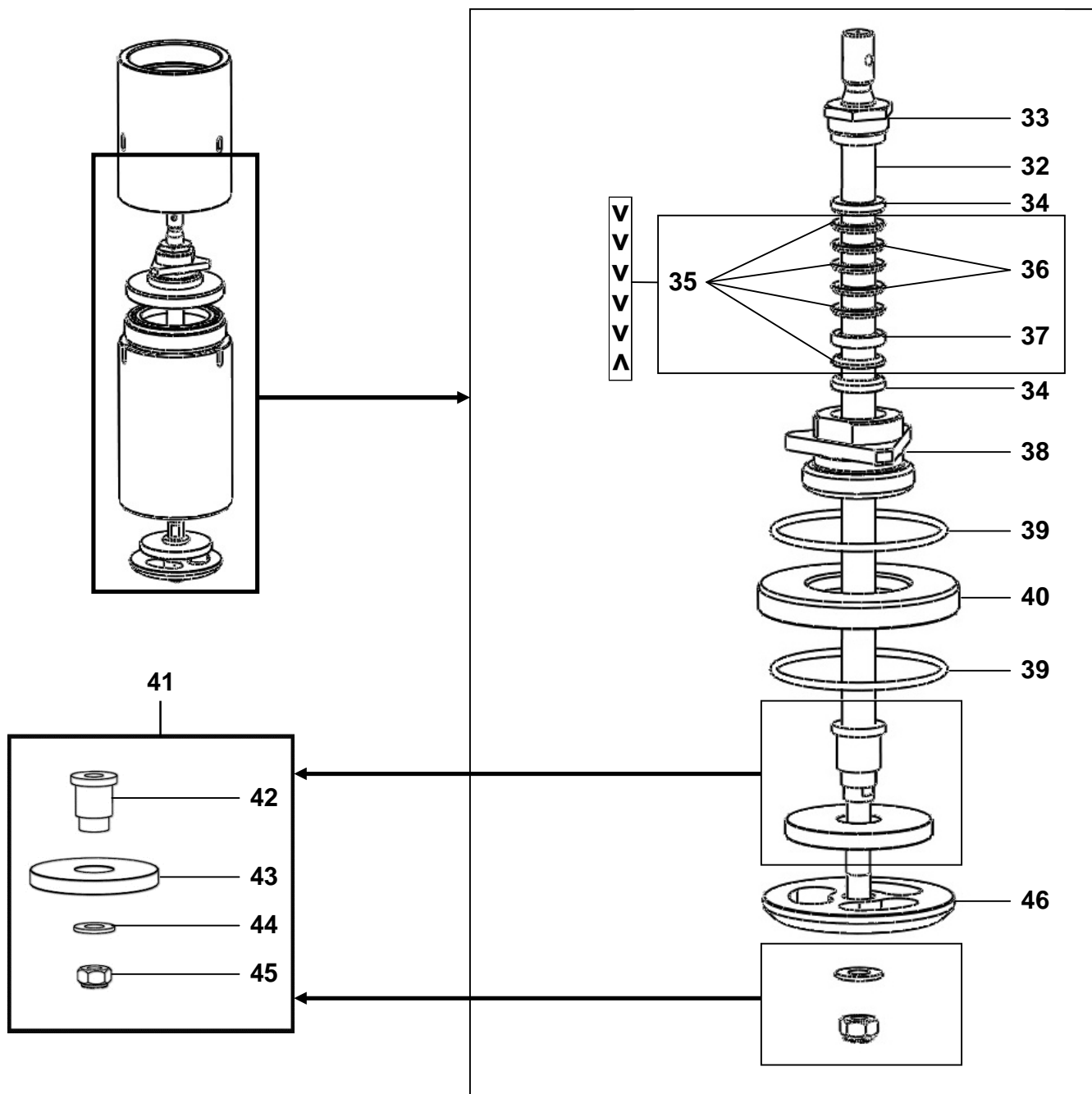

Ind	#	Désignation	Description	Bezeichnung	Denominación	Qté
1	-	<b>Bride supérieure</b>	<b>Upper flange</b>	<b>Oberer Flansch</b>	<b>Brida superior</b>	1
*2	144 250 001	▪ <b>Bride produit</b>	▪ <b>Fluid flange</b>	▪ <b>Material Flansch</b>	▪ <b>Brida producto</b>	1
*3	144 250 096	▪ <b>Cartouche assemblée</b>	▪ <b>Cartridge assembly</b>	▪ <b>Packung komplett</b>	▪ <b>Cartucho equipado</b>	1
4	211 562	▪ ▪ Cartouche	▪ ▪ Cartridge	▪ ▪ Packung	▪ ▪ Cartucho	1
5	930 151 279	▪ ▪ Vis CHc M 8x20	▪ ▪ Screw, CHc M 8x20	▪ ▪ Schraube CHc M 8x20	▪ ▪ Tornillo, CHc M 8x20	12
6	210 731	▪ ▪ Presse-joint mâle	▪ ▪ Male washer	▪ ▪ Stützring konvex	▪ ▪ Prensa junta macho	1
7	210 730	▪ ▪ Presse-joint femelle	▪ ▪ Female washer	▪ ▪ Stützring konkav	▪ ▪ Prensa junta hembra	1
*8	909 420 265	▪ ▪ Joint FKM	▪ ▪ Seal, FKM	▪ ▪ Dichtung aus FKM	▪ ▪ Junta FKM	1
*9	144 250 098	▪ <b>Bride ISO FLANSH F 1"1/2</b>	▪ <b>ISO FLANSH flange F 1"1/2</b>	▪ <b>Flansch ISO FLANSH IG 1"1/2</b>	▪ <b>Brida ISO FLANSH F 1"1/2</b>	1
10	905 260 002	▪ ▪ Bride	▪ ▪ Flange	▪ ▪ Flansch	▪ ▪ Brida	1
11	932 151 607	▪ ▪ Vis CHc M 16x60	▪ ▪ Screw, CHc M 16x60	▪ ▪ Schraube CHc M 16x60	▪ ▪ Tornillo, CHc M 16x60	4
12	050 040 327	▪ ▪ Joint torique	▪ ▪ O Ring	▪ ▪ O-Ring	▪ ▪ Junta tórica	1
*13	144 250 008	Cuve presse-garniture	Wetting-cup	Spülmitteltasse	Cubeta prensa-guarnición	1
*14	210 724	Cale presse-étoupe	Cup block	Distanzring	Calce de prensa-estopa	1
*15	84 395	Joint chevron PU	Chevron seal, PU	Packungsring PU	Junta chevrón, PU	5
*16	210 722	Joint chevron PE	Chevron seal, PE	Packungsring PE	Junta chevrón, PE	1
17	210 431	Bouchon de purge	Drain plug	Ablafschraube	Tapón de vaciado	1
*18	144 250 002	Cylindre	Cylinder	Zylinder	Cilindro	1
*19	84 456	Joint FKM	Seal, FKM	Dichtung aus FKM	Junta FKM	2
*20	144 250 015	<b>Piston assemblé</b>	<b>Piston assembly</b>	<b>Kolben komplett</b>	<b>Pistón equipado</b>	1
21	044 250 015	▪ Piston	▪ Piston	▪ Kolben	▪ Pistón	1
22	210 712	▪ Presse-joint mâle	▪ Male washer	▪ Stützring konvex	▪ Prensa junta macho	1
23	210 713	▪ Presse-joint femelle	▪ Female washer	▪ Stützring konkav	▪ Prensa junta hembra	1
*24	210 726	Joint chevron PE	Chevron seal, PE	Packungsring PE	Junta chevrón, PE	3
*25	211 318	Joint chevron PTFE	Chevron seal, PTFE	Packungsring PTFE	Junta chevrón, PTFE	3
*26	144 250 198	<b>Siège de piston assemblé</b>	<b>Piston seat assembly</b>	<b>Kolbensitz komplett</b>	<b>Asiento de pistón equipado</b>	1
27	044 250 105	▪ Siège de piston	▪ Piston seat	▪ Kolbensitz	▪ Asiento de pistón	1
28	87 532	▪ Bille Ø 32 carbure	▪ Ball Ø 32, carbide	▪ Kugel Ø 32 Hartmetall	▪ Bola Ø 32, carburo	1
29	88 745	▪ Goupille	▪ Pin	▪ Splint	▪ Pasador	1
30	044 250 106	Corps de clapet	Valve body	Saugventilgehäuse	Cuerpo de válvula	1
31	044 250 103	Tube de remplissage	Filling tube	Füllrohr	Tubo de llenado	1
*32	144 250 102	Tige de palette	Shovel rod	Schöpftellerstange	Eje de paleta	1
*33	144 250 195	Presse-étoupe	Cup	Packungsmutter	Prensa estopa	1
34	211 333	Rondelle presse-joint M	M washer	Druckscheibe A	Arandela prensa junta M	2

Ind	#	Désignation	Description	Bezeichnung	Denominación	Qté
*35	211 334	Joint chevron PE	Chevron seal, PE	Packungsring PE	Junta chevrón, PE	4
*36	211 335	Joint chevron PTFE	Chevron seal, PTFE	Packungsring PTFE	Junta chevrón, PTFE	2
37	60 220	Entretoise de presse-étoupe F	Cup spacer F	Distanzring I der Packungsmutter	Tirante de prensa-estopa H	1
*38	144 250 196	Clapet inférieur	Lower valve	Unteres Ventil	Válvula inferior	1
*39	84 469	Joint FKM	Seal, FKM	Dichtung aus FKM	Junta FKM	2
*40	144 250 107	Siège inox	Stainless steel seat	Sitz aus Edelstahl	Asiento de inox	1
<b>*41</b>	<b>144 250 197</b>	<b>Kit entretoise de palette</b>	<b>Shovel spacer kit</b>	<b>Distanz Kit Schöpfteller</b>	<b>Kit tirante de paleta</b>	<b>1</b>
42	210 682	▪ Entretoise de palette	▪ Shovel spacer	▪ Distanzstück für Schöpfteller	▪ Tirante de paleta	1
43	210 683	▪ Rondelle de fermeture	▪ Closing washer	▪ Verschluss Scheibe	▪ Arandela de cierre	1
44	88 550	▪ Rondelle inox	▪ Stainless steel washer	▪ Scheibe aus Edelstahl	▪ Arandela de inox	1
45	88 963	▪ Ecrou inox	▪ Stainless steel nut	▪ Mutter aus Edelstahl	▪ Tuerca de inox	1
*46	144 250 101	Palette inox	Stainless steel shovel	Schöpfteller aus Edelstahl	Paleta de inox	1
*	<b>144 251 196</b>	<b>Pochette de joints (ind. 8, 14, 15 (x5), 16, 19 (x2), 24 (x3), 25 (x3), 35 (x4), 36 (x2), 39 (x2))</b>	<b>Seal kit (ind. 8, 14, 15 (x5), 16, 19 (x2), 24 (x3), 25 (x3), 35 (x4), 36 (x2), 39 (x2))</b>	<b>Dichtungssatz (beinhaltet Pos. 8, 14, 15 (5x), 16, 19 (2x), 24 (3x), 25 (3x), 35 (4x), 36 (2x), 39 (2x))</b>	<b>Bolsa de juntas (índ. 8, 14, 15 (x5), 16, 19 (x2), 24 (x3), 25 (x3), 35 (x4), 36 (x2), 39 (x2))</b>	<b>1</b>

\* Pièces de maintenance préconisées.

\* Preceding the index number denotes a suggested spare part.

\* Bezeichnete Teile sind empfohlene Ersatzteile.

\* Piezas de mantenimiento preventivas.

N C : Non commercialisé.

N S : Denotes parts are not serviceable.

N S : Bezeichnete Teile gibt es nicht einzeln, sondern nur komplett.

N S : no suministrado.



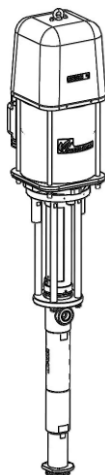
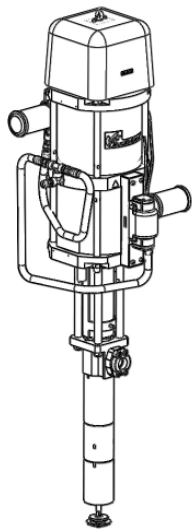

## SHOVEL PUMPS

### THOR

#### PREVENTIVE MAINTENANCE

#### TRANSLATION FROM THE ORIGINAL MANUAL

***IMPORTANT : Before assembly and start-up, please read and clearly understand all the documents relating to this equipment (professional use only).***

THE PICTURES AND DRAWINGS ARE NON CONTRACTUAL. WE RESERVE THE RIGHT TO MAKE CHANGES WITHOUT PRIOR NOTICE.

#### **KREMLIN - REXSON**

150, avenue de Stalingrad

93 245 - STAINS CEDEX – France

☎ : 33 (0)1 49 40 25 25      Fax : 33 (0)1 48 26 07 16

**[www.kremlin-rexson.com](http://www.kremlin-rexson.com)**

OPERATION TO CARRY OUT	FREQUENCY					
	D	W	M	Q	H	Y
<b>GENERAL</b>						
Check earthings	X					
Check leakage from the fittings		X				
Check hoses			X			
Operate the valves			X			
<b>PUMP</b>						
Clean the pistons of the pumps (do not let the material dry)		X				
Check piston rod tightness		X				
Check there is no leak at the upper cartridge		X				
Check the tightness of the upper cartridge (pump stopped and without air on the motor; depressurize the network)			X			
<b>Caution : flush the pump for a long duration shutdown of the installation (more than two weeks)</b>						
<b>MOTOR</b>						
Check the tightness of the piston rod					X	
Check if the control system is clean			X			
Check if the muffler(s) is clogged						X
Check that there is no air leakage						X
Check that air hoses are not damaged						X
Check that the connections between fittings and hoses are correct						X
Check the correct condition of the supply hoses (rubber, setting,...), regulators and gauges						X
Check the tightening of the components						X
Check the fixing of the cover						X
Check the correct operating of the safety valve(s)						X
D : daily W : weekly M : monthly Q : quarterly H : half-yearly Y : yearly						

OPERATION TO CARRY OUT	FREQUENCY					
	D	W	M	Q	H	Y
<b>FLUID SECTION</b>						
Check the tightness of the cup				X		
Check if there is lubricant in the cupel		X				
Disassemble the fluid section, clean the parts with the appropriate cleaning solvent, change the seals and the parts if necessary						X
Change the lubricant if the coloration is too important and change the seals of the upper flange if the problem persists			X			
Clean regularly the cup with lubricant after having drained the lubricant		X				
D : daily W : weekly		M : monthly Q : quarterly		H : half-yearly Y : yearly		

**Note : Frequencies are given as a clue. They must be adapted by the maintenance service of the user for every installation according to the product, the working cadence and the working pressure.**

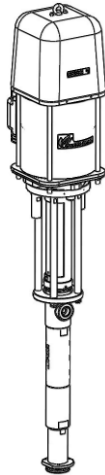
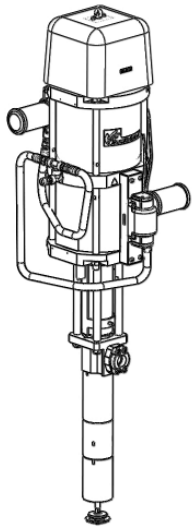

## **SHOVEL PUMPS**

### **THOR**

#### **TROUBLESHOOTING**

#### **TRANSLATION FROM THE ORIGINAL MANUAL**

***IMPORTANT : Before assembly and start-up, please read and clearly understand all the documents relating to the equipment (professional use only).***

THE PICTURES AND DRAWINGS ARE NOT CONTRACTUAL. WE RESERVE THE RIGHT TO MAKE CHANGES WITHOUT PRIOR NOTICE.

#### **KREMLIN - REXSON**

150, avenue de Stalingrad

93 245 - STAINS CEDEX – France

☎ : 33 (0)1 49 40 25 25      Fax : 33 (0)1 48 26 07 16

**[www.kremlin-rexson.com](http://www.kremlin-rexson.com)**

**The pump is manufactured under the ATEX agreement and can not be modified. KREMLIN REXSON will not be held responsible for any failure to comply with that instruction.**

**Guards (air motor cover, coupling shields, housings ...) have been designed for safe use of the equipment.  
The manufacturer will not be held responsible for bodily injury or failure and / or damage to property due to removal or partial removal of the guards**



**CAUTION :**

**Before any intervention on the equipment, shut off the air supply and follow the general safety instructions. Open the drain or the gun to depressurize the gun. The ram must be in the low position.**

TROUBLE	CAUSE	SOLUTION
Pump does not start or stops	The fluid is polymerized, hardened, dried in the pump.	Clean the pump ; change parts if necessary.
	Broken part(s) in the pump	Remove, check and replace.
	Incorrect air supply	Check air pressure.
	Packings of fluid section are stuck	Clean or replace the packings
	Frosting (motor)	Defrost and lubricate using oil.
	Outlet fluid hose is blocked	Change hose.
	Gun nozzle is clogged	Clean it.
The pump cycles continuously (drain valve closed)	No starting up	Check feeding pressure.
	Lack of material	Add material.
	Valve is blocked	Clean or replace.
The pump at stop, the piston carries on going down	Plug or drain valve not tightened	Check and replace parts.
The pump at stop, the piston carries on going up	Head piston seals or upper valve worn or incorrectly mounted	Check and replace parts.
	Plug or drain valve not tightened	

TROUBLE	CAUSE	SOLUTION
The pump does not deliver enough pressure	Insufficient air pressure to the motor (valve insufficiently open, air leak,...)	Check; adjust.
	Insufficient air inlet on the motor or outlet clogged	Check filter and mounting.
	Hose not adapted	Replace hose.
	Cup or head piston seals worn	Check mounting and replace seals.
The pump operates but irregular flow	Air inlet in the suction circuit	Check mounting, state of the parts, tightening of parts and seals.
	Air in the chamber	Check the fittings.
	Valve not tightened or clogged on the seat	Clean.
	Worn valve	Check the valve and replace it.
	Valve incorrectly mounted	Check the valve and mount it.
	Leakage during the exhaust	Check the seals of the power distributor(s); change them if necessary.
	Muffler(s) clogged up	Clean or change.
Fluid leakage through pump body	Wrong tightening of the cylinder	Check cylinder and seals ; replace if necessary.
	Seals missing or damaged	
The piston is going down quickly (simple effect working)	Wrong feeding of the pump	Check the use parameters of the accessories (pressure on follower plate or suction rod,...) ; they can be clogged or not adapted.
	Piston seals incorrectly mounted or damaged	Check the mounting; change if necessary.
The piston goes up quickly	Drain valve worn or damaged	Check and replace parts.
	A foreign product obstructs the drain valve	Clean and check.
	Piston seals incorrectly mounted or damaged	Check the mounting; change if necessary.

<b>TROUBLE</b>	<b>CAUSE</b>	<b>SOLUTION</b>
The piston goes down very quickly until it reaches half stroke and restarts operating slowly	Wrong draining of the pump	Open the drain valve and close it after the outlet of the air bubbles.
Abnormal operating after racing or too important temperature	Head piston or cup seals too tightened, damaged	Check mounting; reduce pumping rhythm ;replace parts if necessary.
	Product drum empty	Fill the drum; check the suction circuit and possible air leakage.
Leakage at the cup seals	Insufficient tightening of the shell	Tighten the shell.
	Bad mounting of the cup seals	Check the mounting.
	Damaged or worn seals	Replace them.
The cup seals get rapidly damaged	The pump operated empty	Abnormal use of the pump.
	No lubricant in the shell (pumped product drying on the piston rod)	Add some lubricant in the shell.
Material flow rate drop	Leakage during the exhaust	Check the the piston seal(s); replace if necessary.
		Check the seals of the power distributor(s); replace them if necessary.
	Muffler(s) clogged up	Clean or change.
Important leakage during the exhaust	Power distributor(s) seals incorrectly mounted	Mount the seals correctly; replace them if necessary.
	Defective Power distributor(s)	Check the operating; replace if necessary.
Motor piston(s) locked	Defective sensors	Adjust or replace the sensors.
	Defective control distributor	Check the operating; change if necessary.
	Defective power distributor(s)	Check the operating; change if necessary.
	Defective pneumatic circuit	Check the circuit.
The motor seems to operate but the shovel fluid section does not deliver product	Defective coupling	Check coupling.



# **SHOVEL PUMP THOR 60-C910-HD**

## ***OPERATING AND START-UP***

### **TRANSLATION OF THE ORIGINAL MANUAL**

***IMPORTANT : Before assembly and start-up, please read and clearly understand all the documents relating to this equipment (professional use only).***

THE PICTURES AND DRAWINGS ARE NON CONTRACTUAL. WE RESERVE THE RIGHT TO MAKE CHANGES WITHOUT PRIOR NOTICE.

#### **KREMLIN - REXSON**

150, avenue de Stalingrad

93 245 - STAINS CEDEX – France

**☎** : 33 (0)1 49 40 25 25      **Fax** : 33 (0)1 48 26 07 16

**[www.kremlin-rexson.com](http://www.kremlin-rexson.com)**



# 1. OPERATING PRINCIPLE

The pneumatic motors are designed to be coupled with the recommended KREMLIN-REXSON fluid section to get the required ratio and flow rate.

The pneumatic motors with rectilinear alternative motions operate thanks to the compressed air supply. The reversing system is carried out by means of :

- one (or two) distributor, model 4/2,
- two sensors,
- a distributor, model 5/2.

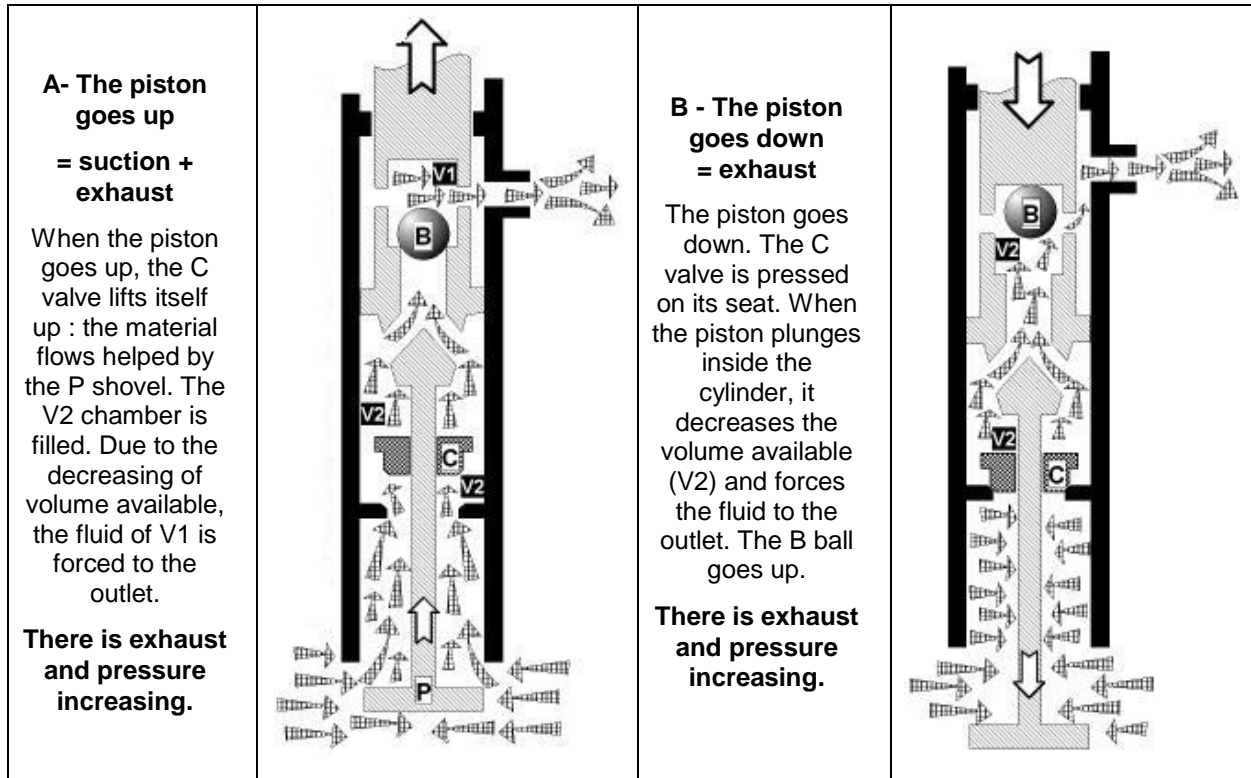

## WARNING!



The frictions due to the displacement of fluid inside the pumps and accessories, as well as the one created by the tightness seals, generate static electricity that may cause fire or explosion. This is why the pump must be grounded.

## 2. INSTALLATION

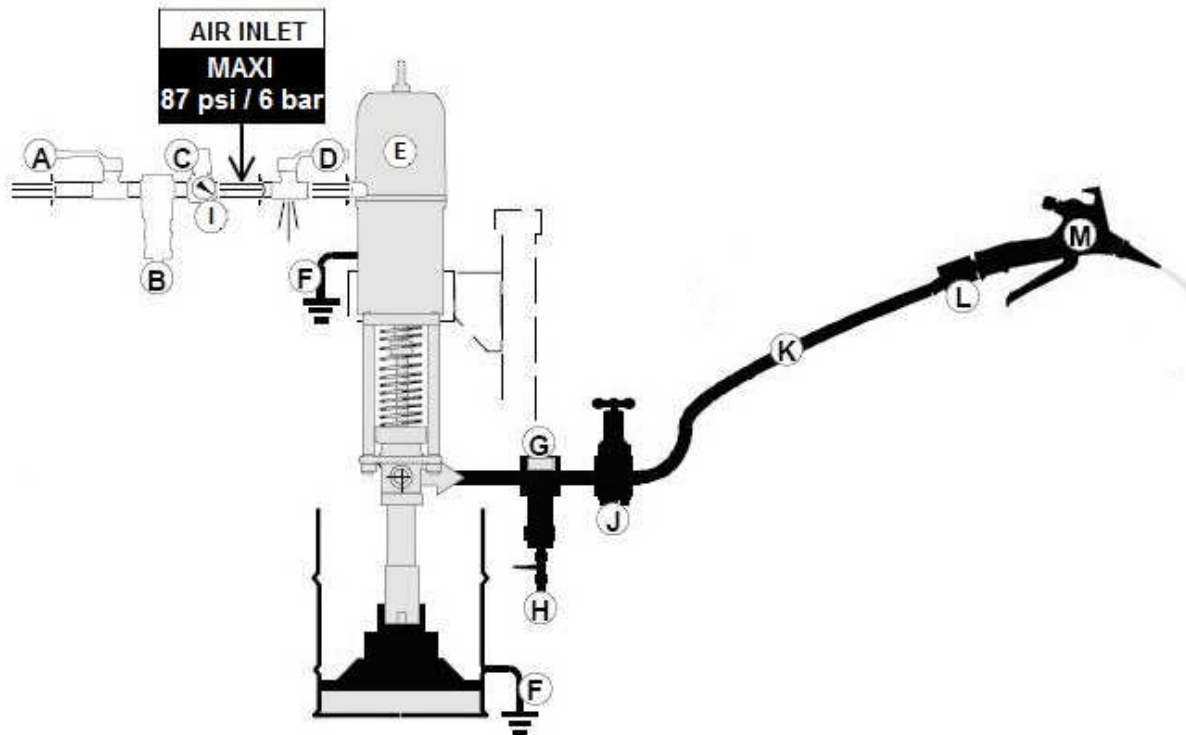

A	Air valve (main shut off valve)	G	Material filter
B	Filter or purifier	H	Fluid drain valve
C	Air regulator	J	Fluid regulator
I	Gauge	K	Hose (HP) with grounding
D	Depressurize valve (air)	L	Swivel fitting
E	Pump	M	Spray gun
F	Grounding		

(For other installation, please contact KREMLIN REXSON).

### 3. USE

- **ADJUSTMENT**

The increase of the motor supply air pressure (via the air regulator) leads to an increase of the number of pump piston returns / mn (cycles) which leads to a flow rate increase and to an outlet pressure increase of the pumped material.

AIR CONSUMPTION OF THE MOTOR	
Pressure of the motor at 6 bar / 87 psi	
Version	daN
9200-2	9000

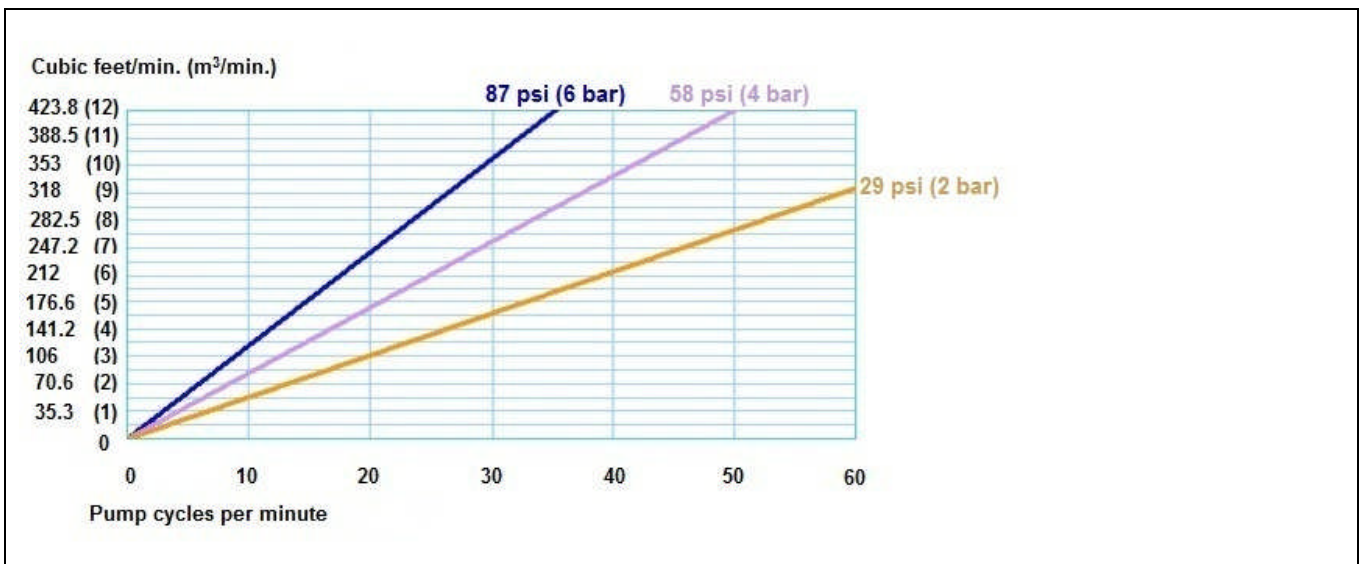

## 4. PNEUMATIC CABLING

**Pneumatic diagram**

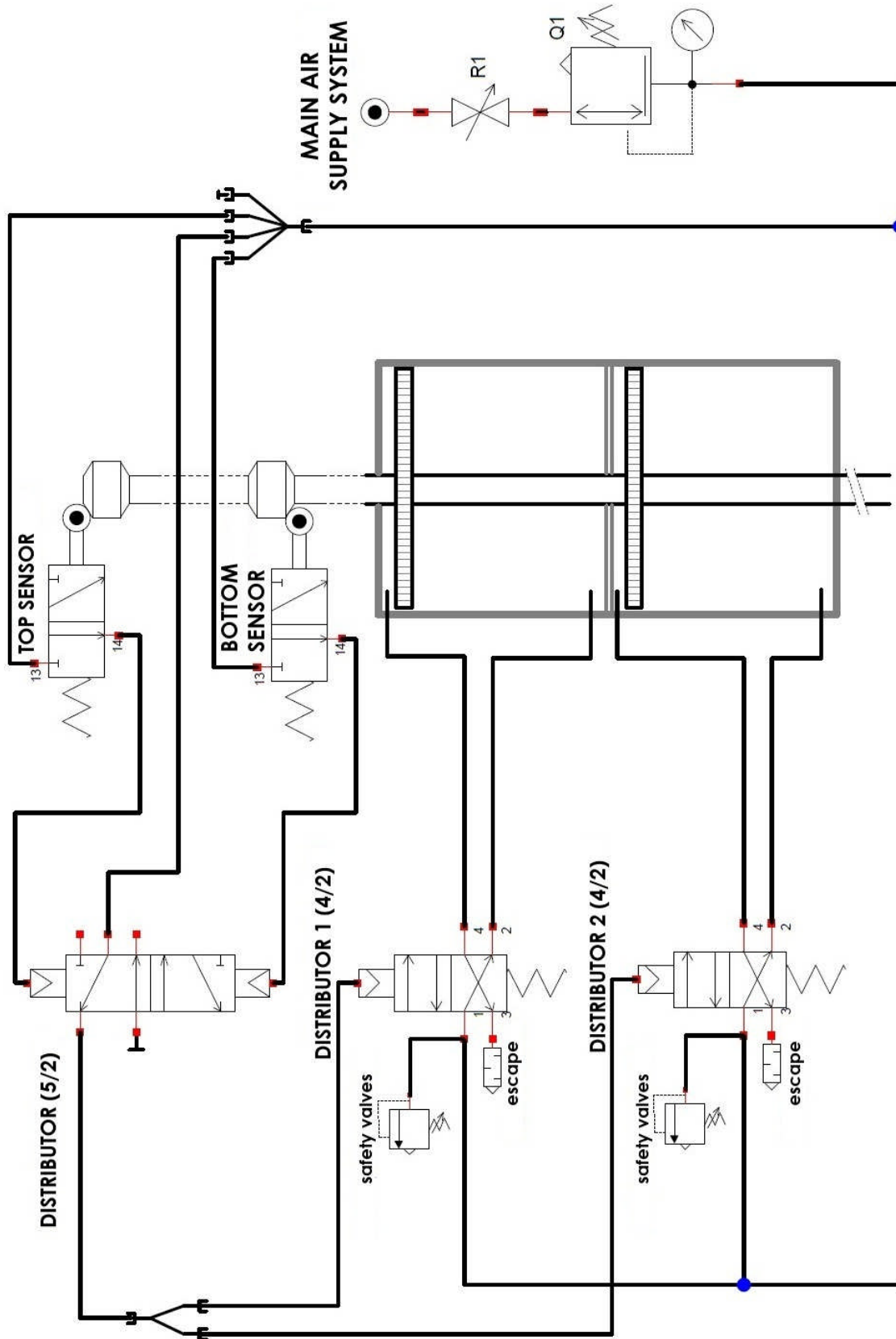

### Standard cabling

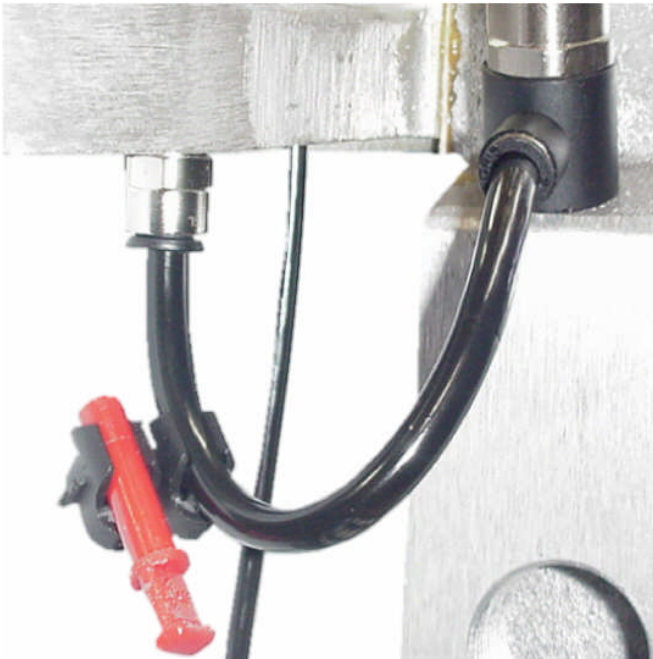

The motors mounted in our plant are cabled in standard piloting. The threshold of the motor starting is about 1.5 bar / 21.7 psi.

### Direct piloting

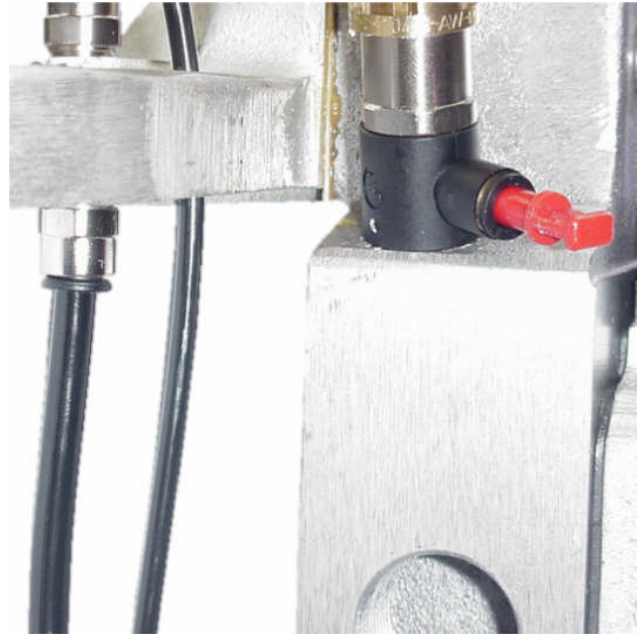

If the user wants to get a motor starting with a pressure of about 0.5 bar / 7.25 psi, the cabling can be modified in direct piloting.

## 5. START UP

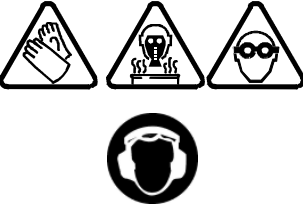
	<p>Protective clothing (gloves, protective masks, glasses, hearing protective earplug, protective clothing,...) should be worn to comply with the recommendations.</p> <p>The working area must be correctly ventilated.</p>
---	--

### ▪ BEFORE STARTING THE EQUIPMENT

**Guards (air motor cover, coupling shields, housings ...) have been designed for safe use of the equipment.**  
**The manufacturer will not be held responsible for bodily injury or failure and / or damage to property due to removal or partial removal of the guards**

## GROUNDING OF THE PUMP

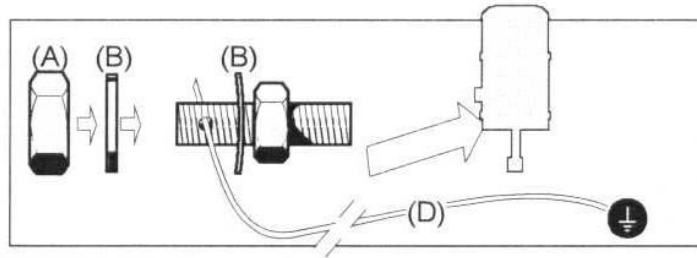

Unscrew the lock-nut (A), introduce between the washers (B) the end of a ground wire (D) (minimum section : 1,5 mm<sup>2</sup>) in the hole of the terminal. Tighten the lock-nut. Connect the other end of the wire to a real "ground", according to the national rules.

A qualified electrician must check the ground continuity. If the continuity is not correct, check the terminal, the electric wire, the U bolt and the ground point. Never operate pump without revolving the trouble.

## CONNECTION OF THE COMPRESSED AIR SUPPLY

For a correct operating and a long duration life of the motor, supply air must be filtered at 5 µ and not lubricated

- You must install a **pressure relief valve** after the air regulator and near to the inlet motor to follow the pressure relief instructions.
- The motor air supply hose should have an internal diameter of at least 19 mm / 0.75".

Then, comply with the instructions as follows :

- Couple the motor to the required fluid section
- Connect the main air supply to the motor
- Adjust the pressure by means of the air regulator

## ▪ ADJUSTMENT

**Guards (air motor cover, coupling shields, housings ...) have been designed for safe use of the equipment.**  
**The manufacturer will not be held responsible for bodily injury or failure and / or damage to property due to removal or partial removal of the guards**

Before starting the equipment, half fill the cup with T lubricant.

Follow these instructions (refert to drawing page 2) :

- The main air valve (A) is closed
- Close the depressurize valve (D)
- Close the drain valve (H)
- Adjust the air regulator (C) on 'O'
- Adjust the fluid regulator (J) on 'O'
- Close the gun (M) (valve, gun,...)
- Open partially the drain valve (H), place a drum to get the drained material
- Open the air valve (A)
- Open the depressurize air valve (D)
- Adjust the air regulator (C) to operate slowly the pump
- Operate to get off air from the follower plate and the pump

- Material must flow continuously (without air bubble)
- Close the drain valve (H)
- Open the fluid regulator (J)
- Trigger the gun (M) (valve,...) and let it on the drum (grounded) to get off air from hoses, gun, valve,...
- Material must flow continuously (without air bubble)
- The pump must stop when the gun is closed (M) (valve, gun,...)

Then adjust :

- air pressure to the regulator (C)
- fluid pressure to the regulator (J)

Depending upon :

- material viscosity
- gun nozzle diameter (M)
- material hoses' length and diameter (K)
- work

**Nota : Before starting the work, check that the working range is correct.** The cup nut must be slightly tightened. A too important tightening would damage the cup seals. A wrench is supplied to allow a correct tightening.

**Tightening of the wetting cup :**

- Fill the cup with T lubricant
- Start the pump, then tighten the cup after 10 minutes, then one hour and then one day of operating
- If you notice a leakage, the cup must be tightened

**Tightening instructions :**

- Depressurize the motor (refer to pressure relief instructions)
- Depressurize the fluid circuit (refer to pressure relief instructions)
- Tighten the cup, clean it and fill it with T lubricant
- Close the pump drain circuits
- Open the motor air valve

▪ **START UP**

**Guards (air motor cover, coupling shields, housings ...) have been designed for safe use of the equipment.**  
**The manufacturer will not be held responsible for bodily injury or failure and / or damage to property due to removal or partial removal of the guards**

The pumps are tested in our workshop with lubricant.  
 Before starting up, you must flush the pump with the appropriate solvent.

## 6. SHUTDOWN AT THE END OF THE WORK

Decrease air pressure regulator (C) until you get 0 bar / 0 psi on the gauge (I).

Trigger the gun to depressurize the system.

Leave the pump full of material.

If the pump is equipped with a follower plate, it must be in contact with the fluid to behave as a cover and prevent from the material drying.

When stopping the pump for a long time, after flushing it, leave it filled with solvent.

Depressurize the system.

### ▪ SHORT SHUTDOWN

Flush the installation with the appropriate solvent to prevent from material drying inside the pump, hoses or accessories. The solvent must flow in a closed circuit until you get a sufficient flushing.

We advice you to stop the pump in 'low reversing' position to prevent from material drying on the piston rod.

- 1 - Decrease air pressure regulator (C) until you get 0 bar / 0 psi on the gauge (I)
- 2 - Trigger the gun to depressurize the system
- 3 - Unscrew the gun air regulator until you get 0 bar / 0 psi on the gauge (I)
- 4 - Remove the gun aircap and the nozzle and soak them into solvent

### ▪ LONG SHUTDOWN

After flushing the installation, to prevent from corrosion, fill the pump with oil solvent to prevent air bubbles and neutralize the residual material.



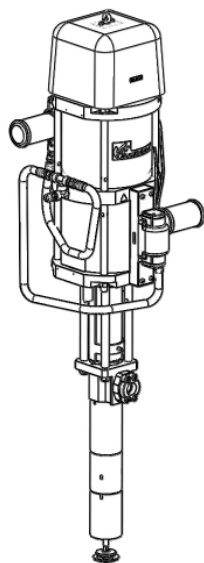

## **SHOVEL PUMP**

**THOR 60-C910-HD**

**TECHNICAL FEATURES**

### **TRANSLATION FROM THE ORIGINAL MANUAL**

***IMPORTANT : Before assembly and start-up, please read and clearly understand all the documents relating to this equipment (professional use only).***

THE PICTURES AND DRAWINGS ARE NON CONTRACTUAL. WE RESERVE THE RIGHT TO MAKE CHANGES WITHOUT PRIOR NOTICE.

#### **KREMLIN - REXSON**

150, avenue de Stalingrad

93 245 - STAINS CEDEX – France

☎ : 33 (0)1 49 40 25 25      Fax : 33 (0)1 48 26 07 16

**[www.kremlin-rexson.com](http://www.kremlin-rexson.com)**

## 1. DESCRIPTION

- Pneumatic pump.

### Recommended for :

- The transfer, the pouring off or the spraying of different liquid or viscous fluids.

## 2. TECHNICAL FEATURES

Motor type ..... 9200-2  
 Pump body type ..... THOR C910-HD  
 Theoretical pressure ratio ..... 60/1  
 Weight (bare pump) .... 165 kg / 364 lbs

Air motor stroke	200 mm	8"
Delivery per cycle	910 cm <sup>3</sup>	30 fl.oz
Free flow (liter/minute)	54,6	54.6
Fluid delivery (30 cycles)	27,3 l	27.3 l
Maximum air operating pressure	6 bar	87 psi
Maximum discharge pressure	360 bar	5220 psi
Weighted sound pressure (LAeq)	76.5 dBa*	76.5 dBa*
Maximum fluid temperature	80°C	176°F
Maximum ambient temperature	40°C	104°F

### Wetted parts :

Cylinder	Stainless steel
Fluide flange cartridge	
Fluid flange	
Valve body	
Valve (drain)	
Seat (drain)	
Piston rod	
Head piston	
Shovel	
Seat (suction)	
Filling tube	
Ball (drain - Ø 32)	Nickel-binder tungsten carbide
Shovel rod	Chromium
Valve (suction)	
ISO FLANSH flange F 1"1/2	Galvanized steel

**Tightness packings :** PTFE 25% Glass + UHMW (support ring : Stainless steel)

*Note : These data are given as a clue.*

### \* Test conditions - Noise level :

- Test duration : 30 s,
- Motor air pressure : 4.5 bar / 65.3 psi,
- Material used : water,
- Flow rate : Pump adjusted at 18 cycles/minute.

▪ FITTINGS

<b>Air</b>	Inlet	F 3/4" G
<b>Fluid</b>	Adaptation plate	Refer to drawing
	Outlet	F 1" 1/2 G

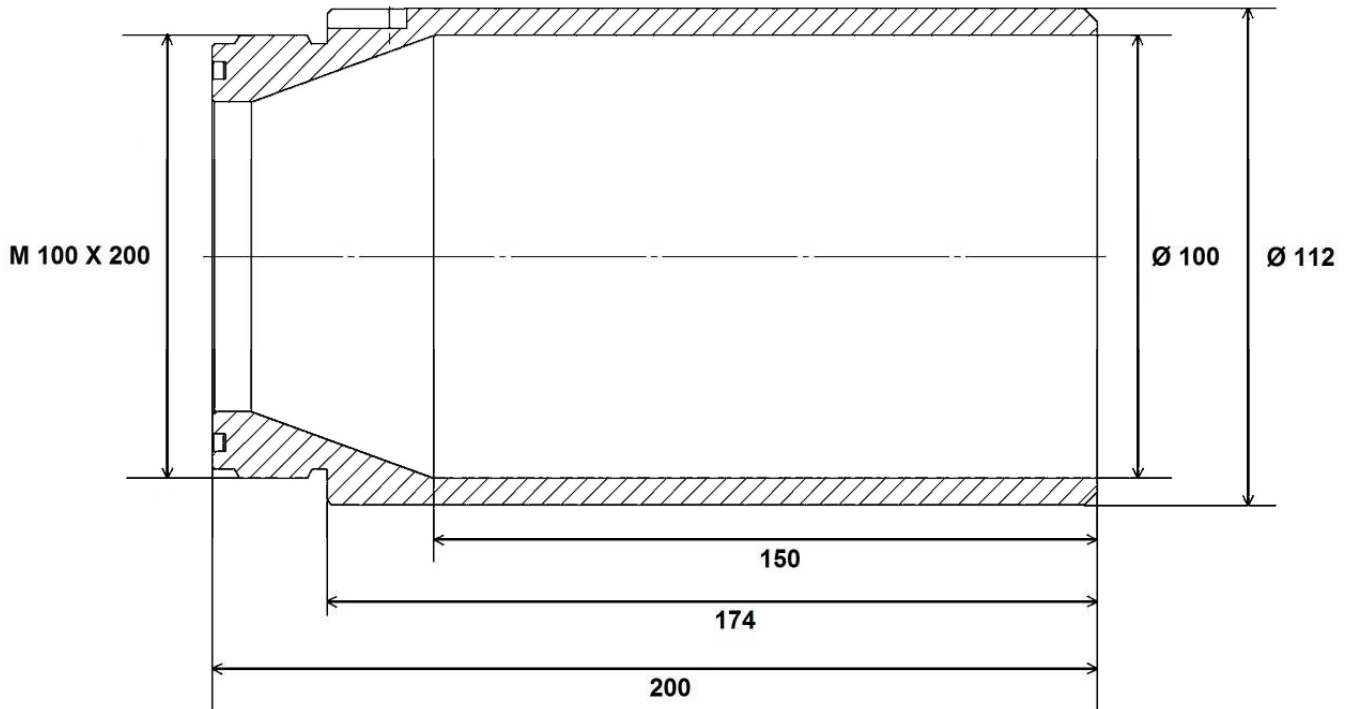



▪ DIMENSIONS

<b>Ind.</b>		<b>mm</b>	<b>"</b>	<b>Ind.</b>	<b>mm</b>	<b>"</b>	<b>Ind.</b>	<b>mm</b>	<b>"</b>
<b>A</b>	Height	2096	82.6	<b>C</b>	600	23.6	<b>D</b>	560	22.1
	Stroke	200	8	<b>E</b>	280	11	<b>F</b>	301	11.9
<b>B</b>	Outlet fluid axis	689	27.1						

▪ DESCRIPTION OF THE LABEL MARKING

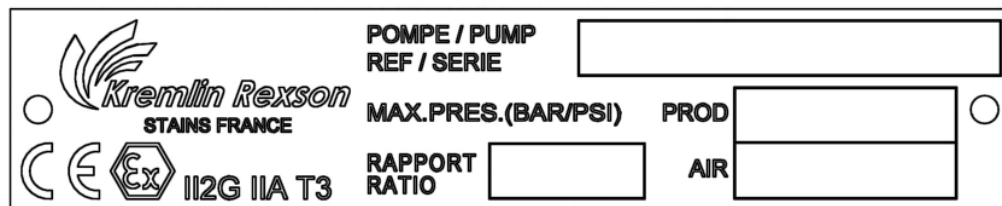
Marking according to the ATEX and Machines directives



<b>KREMLIN REXSON STAINS FRANCE</b>	Name and address of the manufacturer
<b>CE</b>	European Conformity
	<b>II</b> : group II <b>2</b> : class 2 Surface equipment meant to an area in which there is an explosive atmosphere with an excessive mixture of air, gases and vapours, which can occasionally build up during normal operation. <b>G</b> : gas
<b>IIA T3</b>	<b>IIA</b> : Gas group for the equipment category <b>T3</b> : Maximum surface temperature : 200°C / 392°F
<b>POMPE / PUMP</b>	Pump version
<b>REF.</b>	Pump part number
<b>SERIE</b>	Number given by KREMLIN REXSON. The 2 first numbers indicate the manufacturing year.
<b>MAX. PRES. (BAR/PSI)</b>	
<b>PROD</b>	Maximum material pressure
<b>AIR</b>	Maximum air pressure
<b>RAPPORT / RATIO</b>	Pump pressure ratio