

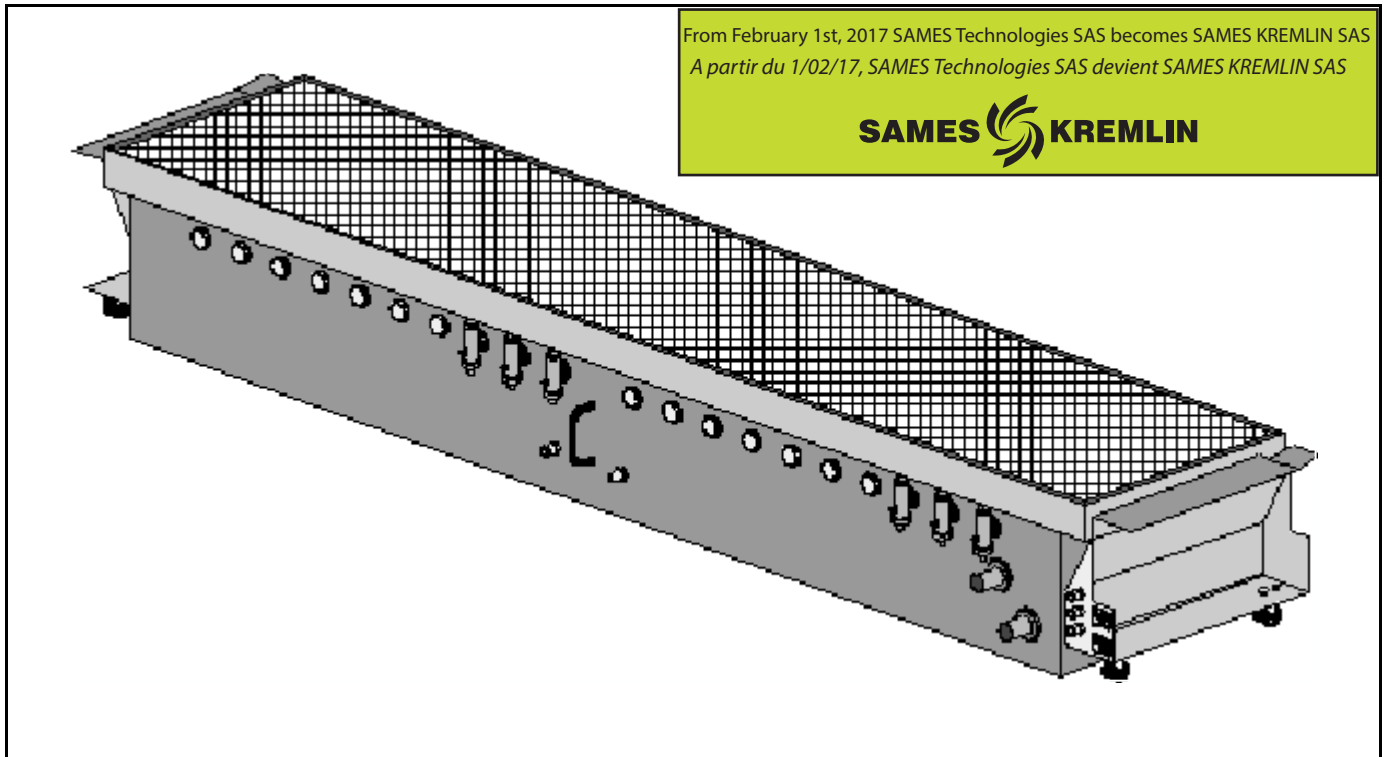

INSTRUCTIONS MANUAL



CSV 700 HOPPER (Ang)

400 micron sieve: Ref. 852 909
710 micron sieve: Ref. 1 504 813
250 micron sieve: Ref. 856 674

Appendix : RT 6132

Nature of the modification : Added information.

Established by: Ph.DE LUCA	Checked by:	Checked by: JC BRISSAUD	Approved by: S LEFEBVRE
--------------------------------------	-------------	-----------------------------------	-----------------------------------

The information and features given in this document are not binding and **SAMES Technologies** reserves the right to modify this equipment without notice.

CONTENTS	Page
1. DESCRIPTION	5
1.1. <i>General description</i>	5
1.2. <i>Technical features</i>	5
1.3. <i>Pneumatic features</i>	5
1.4. <i>Operating principle</i>	6
2. INSTALLATION	7
2.1. <i>Electrical and other connections</i>	7
2.2. <i>Installation of the equipment</i>	7
3. OPERATION	8
4. PROCEDURE TO ADJUST POWDER LEVEL SENSORS	9
5. PREVENTIVE MAINTENANCE	10
6. CORRECTIVE MAINTENANCE	10
7. SPARE PARTS	11
AD01-03-A - CS 126 SUCTION PLUNGER- 854 378.....	11
DL01-01-A - CSV 700 HOPPER	12
DL01-02-A - CSV 700 HOPPER- 400 MICRON SIEVE - 852 909.....	13
DL01-03-A - CSV 700 HOPPER- 250 MICRON SIEVE - 856 674.....	14
DL01-04-A - CSV 700 HOPPER- 710 MICRON SIEVE - 1 504 813.....	15
DL02-A - INSTALLATION OF THE CSV 700 HOPPER ON THE POWDERING BOOTH.....	16

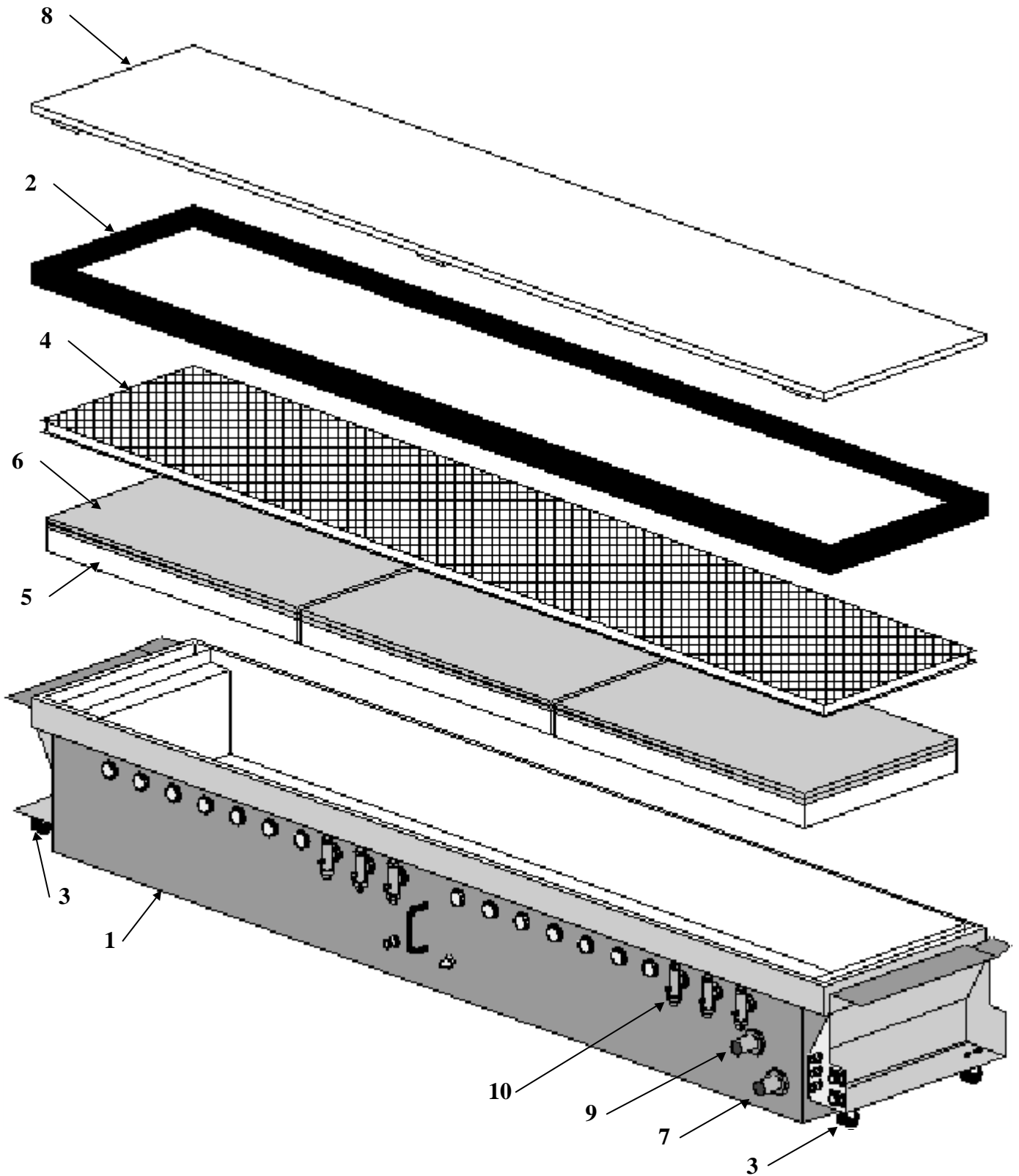

Fig. 1

1. DESCRIPTION

1.1. GENERAL DESCRIPTION

The **CSV 700** hopper is intended for exclusive use with a "powdering booth". This device is one component of a machine commonly known as a "powdering booth", integrated in a surface coating installation.

The incorporation declaration and the conformity plate should be supplied for the whole "powdering booth".

The **CSV 700** hopper is made up of the following components:

- a hopper barrel (1), mounted on wheels (3), fitted with a seal (2),
- a 400 ?m vibrating sieve (4),
- three hopper bottoms (5) onto which a porous plate (6) is attached,
- a "low" powder level detector (7).

The **CSV 700** hopper can be equipped with the following optional devices:

- a cover (8),
- a 250 or a 710 ?m vibrating sieve (4),
- a "high" powder level detector (9),
- between one and twenty suction plungers (10).

1.2. TECHNICAL FEATURES

1.2.1. GENERAL FEATURES

- Height..... 320 mm approx.
- Width 338 mm.
- Depth..... 280 mm approx.
- Weight 80 kg empty.
- Useful contents 97 l (i.e. approx. 50 kg of fluidised powder).
- Max. number of plungers 20.

1.3. PNEUMATIC FEATURES

- Fluidisation air pressure 1 bar.
- Consumption of dried, filtered air 12 for 15 m³ /h for fluidisation (*).
- Characteristics of compressed air supply according to the **NF ISO** standard **8573-1**:
 - ? max. dew point at 6 bar..... class 4 i.e. + 3 °C (+ 38 °F),
 - ? max. granulometry of solid pollutants..... class 3 i.e. 5 microns,
 - ? max. oil concentration class 1 i.e. 0.01 mg/ m³ (*),
 - ? max. concentration of solid pollutants..... class 3 i.e. 5 mg/ m³ (*).

(*): m³: volume at normal atmospheric pressure (1013 mbar) at a temperature of 20 °C (68 °F).

1.3.1.FEATURES OF THE LEVEL DETECTOR

- Supply voltage 20 / 250 V AC/DC.
- Output current in rush.....350 mA AC (+ 50 °C (+ 122 °F)),
100 mA DC (+ 80 °C (+ 176 °F)).
- Output current on call 2.2 A (20 ms / 0.5 Hz).
- Max. output current..... 5 mA.
- Voltage drop / max. load.....< 6,5 V / 250 V AC.
- Residual current < 2,5 mA / 250 V A,
< 1,3 mA / 110 V AC,
< 0,8 mA / 24 V CC.
- Switching frequency.....25 Hz AC / 30 Hz DC.
- LED switching indication..... Yellow.
- Ambient temperature -25 / + 80 °C (-13/+ 176 °F).
- Protection IP 65.
- EMC group 2.
- Box.....PBTP polycarbonate cover.
- Connection..... terminals up to 2.5 mm² .
- Connection diagram.....see **fig. 2**.

1.4. OPERATING PRINCIPLE

The hopper is supplied with compressed air through the porous bottoms.

The upward air flow from the bottom ensures fluidisation of the powder contained in the hopper (the powder is sieved previously).

The hopper can be fitted with up to 20 suction plungers enabling supply of up to 20 powder projectors.

IMPORTANT : IT IS DANGEROUS TO USE THIS DEVICE FOR USES OTHER THAN THAT INDICATED ABOVE.

2. INSTALLATION

2.1. ELECTRICAL AND OTHER CONNECTIONS

The **CSV 700** hopper is electrically earthed via contact with the frame of the "powdering booth".

It is therefore necessary to ensure that the powdering booth is earthed.

Connect the level detector (C1-C2 Fig.2) following the diagram above :

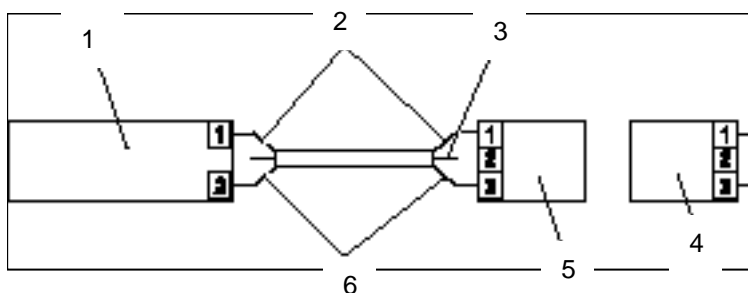

1	Level detector
2	Blue wire
3	Yellow - green wire (not used)
4	Female plug + wire clamp
5	Base plate + box + wire clamp
6	Brown wire

2.2. INSTALLATION OF THE EQUIPMENT

The **CSV 700** hopper should be installed by a professional.

For modification of the hopper or its installation, the advice of the installer must be followed.

3. OPERATION

Connect the following components:

- the three fluidisation air hoses (Dia. 6/8 mm) [T1], [T2] and [T3] on the powder hopper,
- the sieve vibrator air hose (Dia. 6/8 mm) [T4],
- the connection socket [C1] of the "low" powder level detector,
- the connection socket [C2] of the "high" powder level detector, if applicable.

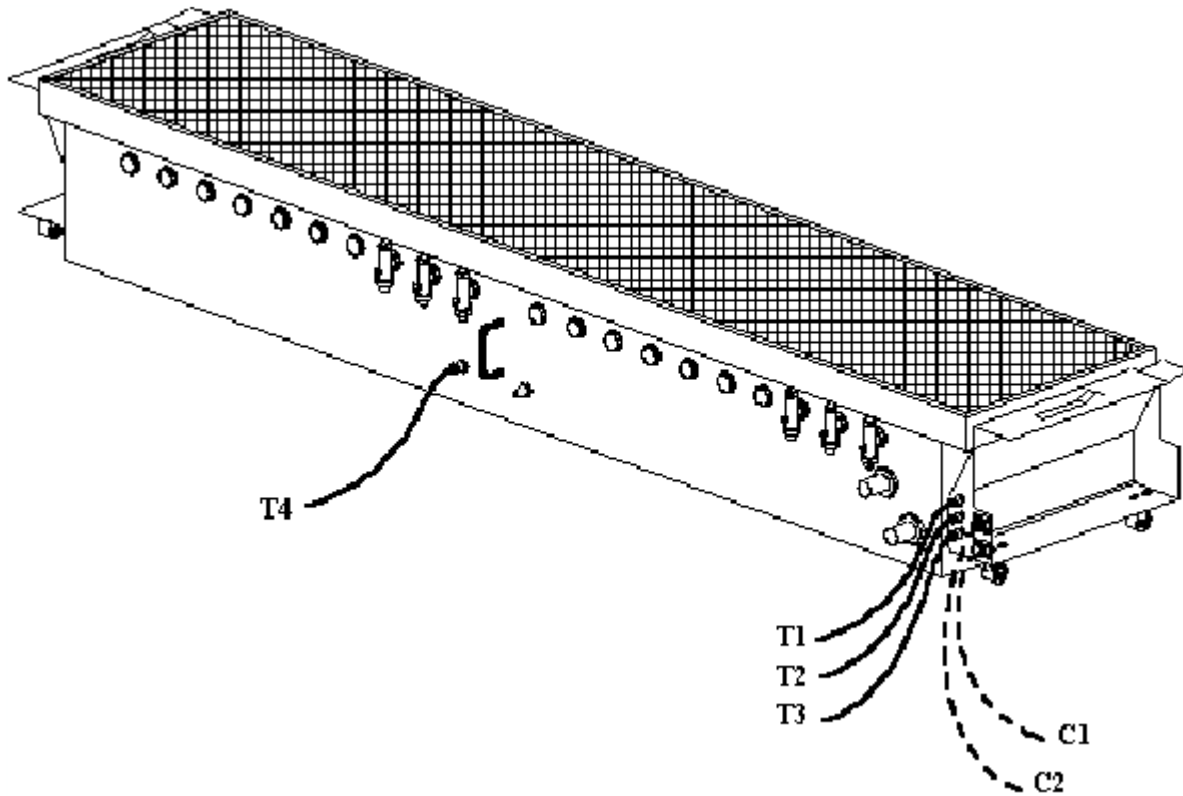

Fig. 2

4. PROCEDURE TO ADJUST POWDER LEVEL SENSORS

The powder sensor which has been beforehand connected to power must be in contact with the fluidized powder. The adjustment is done thanks to the small knob located on the back of the sensor body.

Step 1 : With the help of a small flat screwdriver, turn the screw anticlockwise, until the led of the sensor goes off.

Nota: this operation is not necessary if the led is already off.

Step 2 : Turn the knob clockwise very slowly and stop as soon as the led switches on. Turn gently backward (about 10° to 30°), check the led still lights. If this should not be the case, repeat the operation turning less anticlockwise.

Step 3 :

- Test stopping the fluidization process in the hopper in order to reduce the height of powder and check that the level sensor is not in contact with powder any more. Then check that the led of sensor is off. Otherwise perform again step 2.

- Switch on again the fluidization process in the hopper. The fact that the led switches on in contact with fluidized powder shows that adjustment is correct. If this should not be the case, perform again the adjustment following step 2

Nota : Should different type of powder are used it is possible that adjustment of the sensor(s) has to be performed again according to the different types (plugging or not, more or less fluidizable, etc). Therefore it is recommended to start the adjustments with the powders which can lead to these types of problems.

5. PREVENTIVE MAINTENANCE

IMPORTANT : Only use compressed air, a cloth or a brush for cleaning operations.

Never use water for cleaning this piece of equipment.

Soiling and wear of the equipment due to powder passage will depend on the nature of the powder used.

Therefore, the maintenance frequency indicated below is given for information only.

The user should develop his own maintenance program as he gains experience of **SAMES** equipment.

We recommend following the maintenance program below initially:

MAINTENANCE FREQUENCY	ACTION
? Daily.	? Check the state of the equipment.
? Every 8 working hours.	? After disconnecting the "dilution" and "injection" air supply ho-ses, remove the suction plunger(s) and clean it(them) using compressed air or a suction pump.
? Weekly.	? Clean the vibrating sieve using an air jet.
? Every 40 to 60 working hours.	? Change the "venturi" ejector of the suction plunger(s) if necessary ? Check the cleanliness of the suction plunger(s). Clean or change it(them) if necessary.

6. CORRECTIVE MAINTENANCE

SYMPTOMS	PROBABLE CAUSE	REMEDIES
? The powder comes out in jerks.	? Insufficient powder fluidization.	? Adjust the "fluidization" air pressure to a sufficient value.
	? Unsuitable powder transport hose diameter.	? Change the powder transport hose.
? The powder does not flow properly out of the sieve.	? Blocked sieve.	? Clean or change the sieve.
	? Vibrator malfunction.	? Check the vibrator and replace it if necessary.

7. SPARE PARTS

CS 126 SUCTION PLUNGER

See the user manual : RT 6132

DL01-01-A - CSV 700 HOPPER

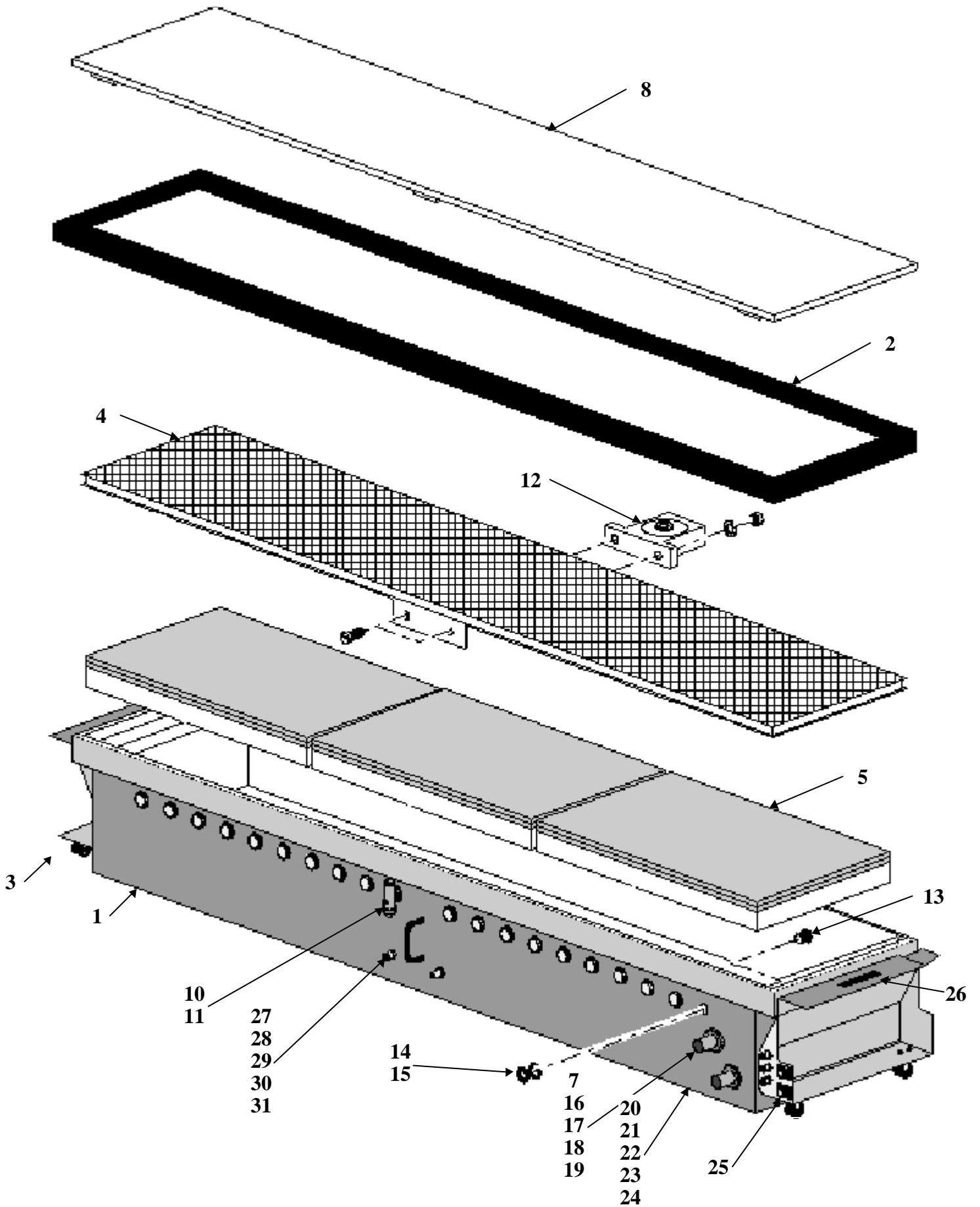

DL01-02-A - CSV 700 HOPPER- 400 MICRON SIEVE- 852 909

Refer to plate DL01-01

Item	Article code	Description	Qty	Sales unit
	852 909	CSV 700 HOPPER - 400 M - mod 05/95		1
1	419 181	Hopper barrel	1	1
2	739 728	Hopper seal	1	1
3	Q1V RGP 041	Pivoting wheel D = 50	4	1
4	855 487	Fitted 400 micron sieve	1	1
	855 823	Fitted 250 micron sieve	Optional	1
	1 504 815	Fitted 710 micron sieve	Optional	1
5	419 191	Mounted hopper bottom	3	1
7	E6K DDP 066	Low level detector	1	1
8	930 451	Hopper cover	Optional	1
9	856 989	High level detector	Optional	1
10	854 378	CS 126 plunger (see sheet AD01-03)	Optional	1
11	X2B DVN 030	M 30 washer	Optional	1
12	K3V ARC 009	Pneumatic vibrator	1	1
13	E3R BBN 021	PG 21 plug	20	1
14	E3R PLS 045	PG 21 nut	20	1
15	E3R PLJ 021	PG 21 washer	20	1
16	E3R BBN 036	PG 36 polyamide blocking plug	2	1
17	E3R PCN 036	PG 36 rilsan nut	3	1
18	E3R PLJ 036	PG 36 flat seal	3	1
19	548 901	Detector support	1	1
20	F6R LUS 269	Connection fitting	3	1
21	F6R LRP 318	Male-female reduction	1	1
22	F6R LUS 238	Coupler	3	1
23	F6R LJR 274	Plug socket	3	1
24	F6R LJR 275	Single socket union	4	1
25	E4P TFS 096	3 contact socket	1	1
26	640 481	Contact strip	2	1
27	F6R LUS 410	Connection fitting	1	1
28	F6R LZX 417	Seal	10	1
29	F6R LJR 194	Coupler	1	1
30	F6R LJR 195	Plug socket	1	1
31	F6R LUS 459	Single socket union	2	1

	U1C BBT 003	Blue rislan hose Dia. 6/8 mm		m
--	-------------	------------------------------	--	---

DL01-03-A - CSV 700 HOPPER- 250 MICRON SIEVE- 856 674

Refer to plate DL01-01

Item	Article code	Description	Qty	Sales unit
	856 674	CSV 700 HOPPER - 250 M - mod 05/95		1
1	419 181	Hopper barrel	1	1
2	739 728	Hopper seal	1	1
3	Q1V RGP 041	Pivoting wheel D = 50	4	1
4	855 487	Fitted 400 micron sieve	Optional	1
	855 823	Fitted 250 micron sieve	1	1
	1 504 815	Fitted 710 micron sieve	Optional	1
5	419 191	Mounted hopper bottom	3	1
7	E6K DDP 066	Low level detector	1	1
8	930 451	Hopper cover	Optional	1
9	856 989	High level detector	Optional	1
10	854 378	CS 126 plunger (see sheet AD01-03)	Optional	1
11	X2B DVN 030	M 30 washer	Optional	1
12	K3V ARC 009	Pneumatic vibrator	1	1
13	E3R BBN 021	PG 21 plug	20	1
14	E3R PLS 045	PG 21 nut	20	1
15	E3R PLJ 021	PG 21 washer	20	1
16	E3R BBN 036	PG 36 polyamide blocking plug	2	1
17	E3R PCN 036	PG 36 rilsan nut	3	1
18	E3R PLJ 036	PG 36 flat seal	3	1
19	548 901	Detector support	1	1
20	F6R LUS 269	Connection fitting	3	1
21	F6R LRP 318	Male-female reduction	1	1
22	F6R LUS 238	Coupler	3	1
23	F6R LJR 274	Plug socket	3	1
24	F6R LJR 275	Single socket union	4	1
25	E4P TFS 096	3 contact socket	1	1
26	640 481	Contact strip	2	1
27	F6R LUS 410	Connection fitting	1	1
28	F6R LZX 417	Seal	10	1
29	F6R LJR 194	Coupler	1	1
30	F6R LJR 195	Plug socket	1	1
31	F6R LUS 459	Single socket union	2	1
	U1C BBT 003	Blue rilsan hose Dia. 6/8 mm		m

DL01-04-A - CSV 700 HOPPER- 710 MICRON SIEVE- 1 504 813

Refer to plate DL01-01

Item	Article code	Description	Qty	Sales unit
	1 504 813	CSV 700 HOPPER - 710 M - mod 05/95		1
1	419 181	Hopper barrel	1	1
2	739 728	Hopper seal	1	1
3	Q1V RGP 041	Pivoting wheel D = 50	4	1
4	855 487	Fitted 400 micron sieve	Optional	1
	855 823	Fitted 250 micron sieve	Optional	1
	1 504 815	Fitted 710 micron sieve	1	1
5	419 191	Mounted hopper bottom	3	1
7	E6K DDP 066	Low level detector	1	1
8	930 451	Hopper cover	Optional	1
9	856 989	High level detector	Optional	1
10	854 378	CS 126 plunger (see sheet AD01-03)	Optional	1
11	X2B DVN 030	M 30 washer	Optional	1
12	K3V ARC 009	Pneumatic vibrator	1	1
13	E3R BBN 021	PG 21 plug	20	1
14	E3R PLS 045	PG 21 nut	20	1
15	E3R PLJ 021	PG 21 washer	20	1
16	E3R BBN 036	PG 36 polyamide blocking plug	2	1
17	E3R PCN 036	PG 36 rilsan nut	3	1
18	E3R PLJ 036	PG 36 flat seal	3	1
19	548 901	Detector support	1	1
20	F6R LUS 269	Connection fitting	3	1
21	F6R LRP 318	Male-female reduction	1	1
22	F6R LUS 238	Coupler	3	1
23	F6R LJR 274	Plug socket	3	1
24	F6R LJR 275	Single socket union	4	1
25	E4P TFS 096	3 contact socket	1	1
26	640 481	Contact strip	2	1
27	F6R LUS 410	Connection fitting	1	1
28	F6R LZX 417	Seal	10	1
29	F6R LJR 194	Coupler	1	1
30	F6R LJR 195	Plug socket	1	1
31	F6R LUS 459	Single socket union	2	1
	U1C BBT 003	Blue rilsan hose Dia. 6/8 mm		m

DL02-A - INSTALLATION OF THE CSV 700 HOPPER ON THE POWDERING BOOTH

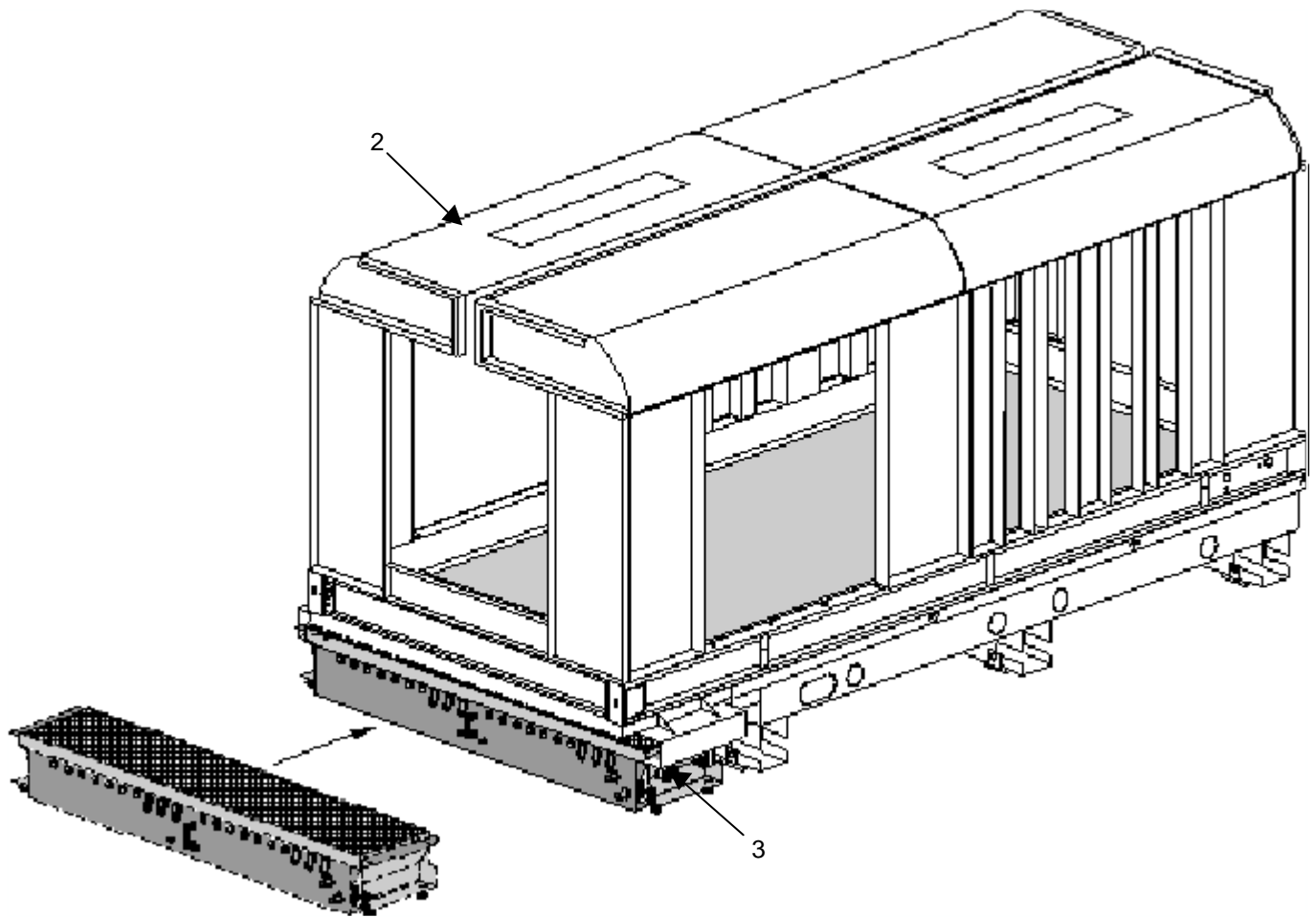

1. INSTALLATION OF THE CSV 700 HOPPER BELOW THE POWDERING BOOTH

NB: only 1 hopper is used for 1,2 and 3 module powdering booths,
2 hoppers are required for the 4 module powdering booth.

- Place the **CSV 700** hopper (1) opposite the powdering booth (2).
- Place the **CSV 700** hopper in the powdering booth's lifting device (3).
- Activate the jacks using the control device located in the small cabinet to lift the hopper onto the booth.
- See the instruction manual for the **RT 6053** powdering booth for more information on the use of the hopper with the powdering booth.

2. DISMANTLING THE HOPPER

- Separate the **CSV 700** hopper from the powdering booth by activating the jacks.
- Remove the hopper(1).