

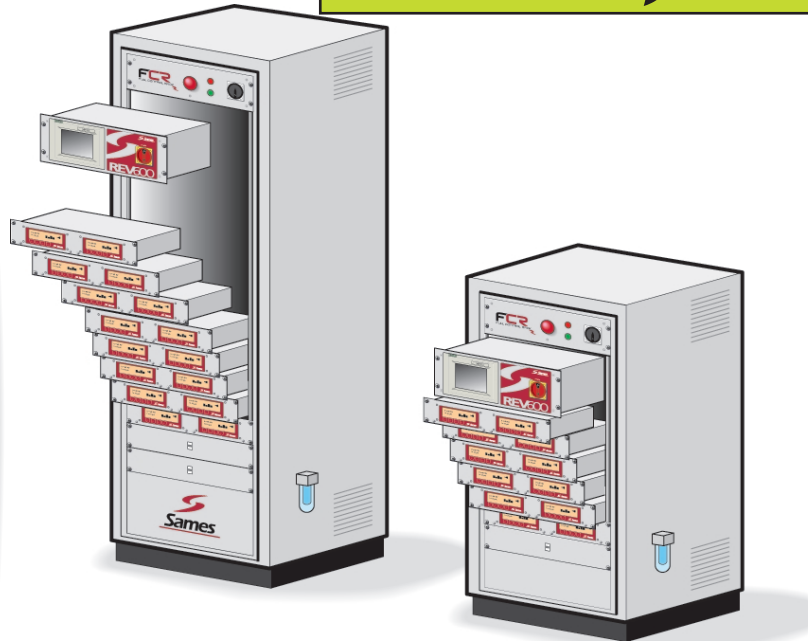

From February 1st, 2017 SAMES Technologies SAS becomes SAMES KREMLIN SAS  
A partir du 1/02/17, SAMES Technologies SAS devient SAMES KREMLIN SAS



# User manual

## FCR Cabinets



**SAS SAMES Technologies.** 13 Chemin de Malacher, 38243 Meylan Cedex  
Tel.: 33 (0)4 76 41 60 60 - Fax: 33 (0)4 76 41 60 90 - [www.sames.com](http://www.sames.com)

All communication or reproduction of this document, in any form whatsoever and all use or communication of its contents are forbidden without express written authorisation from SAMES Technologies.

The descriptions and characteristics mentioned in this document are subject to change without prior notice.

© **SAMES Technologies 2007**



**WARNING:** SAS Sames Technologies is registered with the Ministry of Labour as a training institution.  
Throughout the year, our company offers training courses in the operation and maintenance of your equipment.  
A catalogue is available on request. Choose from a wide range of courses to acquire the skills or knowledge that is required to match your production requirements and objectives.  
Our training courses can be delivered at your site or in the training centre at our Meylan head office.

**Training department:**  
**Tel. 33 (0)4 76 41 60 04**  
**E-mail: [formation-client@sames.com](mailto:formation-client@sames.com)**

**SAS Sames Technologies** operating manuals are written in French and translated into English, German, Spanish, Italian and Portuguese.

The French version is deemed the official text and Sames will not be liable for the translations into other languages.

## FCR Cabinets

1. Health and Safety Instructions	5
2. Description of FCR cabinet	6
2.1. <i>Presentation</i>	6
2.1.1. <i>Presentation of electrical power supply modules</i>	7
2.1.2. <i>Presentation of pneumatic equipment</i>	9
2.2. <i>Function</i>	12
2.3. <i>Block diagram of an installation</i>	13
3. Technical characteristics	14
3.1. <i>General characteristics</i>	14
3.1.1. <i>FCR cabinet</i>	14
3.1.2. <i>Electrical power supply module</i>	14
3.2. <i>Electrical characteristics</i>	15
3.2.1. <i>FCR cabinet</i>	15
3.2.2. <i>Electrical power supply module</i>	15
3.3. <i>Pneumatic characteristics</i>	16
3.4. <i>24V DC power supply characteristics</i>	16
3.5. <i>Characteristics of Input/Output interfacing with the outside</i>	17
4. Installation	18
4.1. <i>Connection of control modules</i>	18
5. Installation startup and shutdown procedures	19
5.1. <i>Startup procedures</i>	19
5.1.1. <i>Power-up</i>	19
5.1.2. <i>Pressurisation</i>	19
5.1.3. <i>Booth startup</i>	19
5.2. <i>Shutdown procedures</i>	19
5.2.1. <i>Switching off</i>	19
5.2.2. <i>Power-down</i>	19
5.2.3. <i>Depressurisation</i>	19
6. Adjustments	20
6.1. <i>Front side of mini-PLC</i>	21
6.2. <i>LCD display</i>	22
6.2.1. <i>Setting parameters</i>	22
7. Connection	24
7.1. <i>General</i>	24
7.2. <i>Correspondence between the terminal box and the electrical diagram</i>	25
7.3. <i>Ground Connection</i>	26
7.4. <i>Connection of module supply voltage</i>	26
7.5. <i>Connection of 400/230V transformer</i>	28
7.6. <i>Connection of VCR converter modules or REV 600 modules</i>	30
7.7. <i>Connection of MCR control module</i>	31

7.8. Connection of spraying modules . . . . .	32
7.8.1. CRN 457 control module . . . . .	32
7.8.2. TCR control module . . . . .	34
7.8.3. TRJ 102 control module . . . . .	36
7.9. Connection of interfaces with the outside . . . . .	38
7.9.1. Part detection . . . . .	38
7.9.2. Low powder level detection . . . . .	40
7.9.3. External fault lamp . . . . .	41
7.9.4. External fault input / booth ventilation running / conveyor running	42
7.9.5. External emergency stop inputs . . . . .	43
7.9.6. Conveyor authorization / Emergency stop outputs . . . . .	44
8. Spare parts- - - - -	45

## 1. Health and Safety Instructions



**WARNING:** Work must only be carried out in the electrical compartment by qualified personnel trained for electrical work.



**WARNING:** This equipment may be hazardous when not used following the safety rules described in this manual.

- The FCR cabinet must not be modified by the user and has to stay in conformity with the installation realized by Sames Technologies. Any modification carried out is under the responsibility of the owner.
- The FCR cabinet must be installed outside of ATEX area.
- The FCR cabinet must be installed away from the powder polluted area.
- The FCR cabinet cannot be installed out of doors.
- The FCR cabinet must be installed in a zone where the ambient temperature is lower or equals in 35°C and reasonably dry (hygrometry < 85 % without condensation).  
With the option air conditioning, the FCR cabinet can be installed in a zone where the temperature is > 35°C.
- The FCR cabinet must be necessarily connected to the ground of the factory by a green / yellow wire diameter at least equal to the diameter of the wires of power supply.
- The FCR cabinet necessarily has to work with all its panels of tolerance planned at the origin of way of keeping the degree of waterproofness being enough for avoiding every risk of direct or indirect contacts.
- Only spare part Sames Technologies, or a repair made by the service repair Sames insure and guarantee the safety of functioning of the FCR cabinet.
- Switch off the power supply and / or pneumatic before any intervention in the FCR cabinet.
- The information indicating that the ventilation of the booth is in functioning must be necessarily connected to the FCR cabinet so as to authorize the spraying only when the ventilation of the booth is present. If this information is not connected or is non-existent, the use is then under the responsibility of the owner.

## 2. Description of FCR cabinet

### 2.1. Presentation

The standard FCR (Full Control Rack) cabinet is designed to supply and control the flow of powder or liquid paint to spraying equipment in a ventilated booth.

In its powder version, it is designed to receive the different control modules manufactured by SAMES.

It is delivered in the form of a bare cabinet cell placed on the floor on a 100 mm base with, on the front side:

- Installation for standard 19" control racks (not supplied).
- Electrical power supply modules.
- Pneumatic supply kit.

Two models are available:

- A low version "**FCR 12**" with 18 Us available, capable of managing and supplying up to 12 spraying modules and a maximum of 2 REV 600 or MCR/ VCR axes maxi.
- A tall version "**FCR 24**" with 32 Us available, capable of managing and supplying up to 24 spraying modules and a maximum of 2 REV 600 axes or 4 MCR /VCR axes maxi.

Tall version, 32 Us available

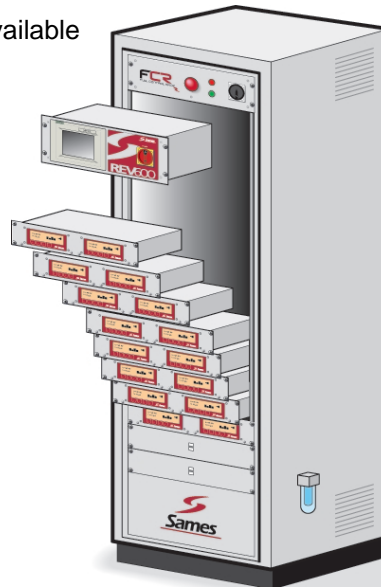

Low version, 18 Us available

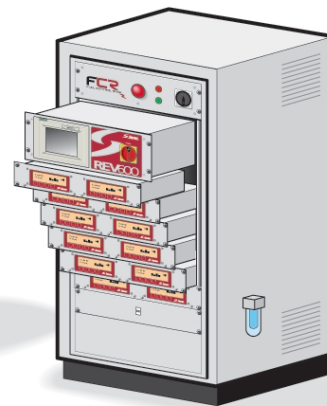

### 2.1.1. Presentation of electrical power supply modules

The module is installed by default at the top of the standard FCR cabinet at the head of the modules. It is fastened to the cabinet by four screws. This module (P/N: 900002782) is rackable, 19 inch units, and its height is 3U.

#### Front side

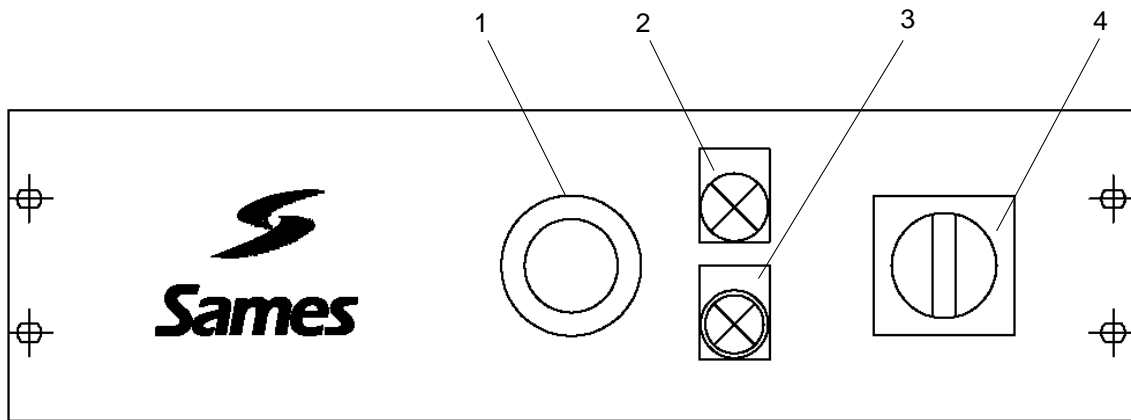

Item	Description	Function
1	"Push-button" type switch	- Switches off the installation. Emergency Stop - Switches off power supply to moving parts and atomizers with a category 3 safety level.
2	Red "Fault" indicator light	- Indicates an external fault, a lack of powder, a lack of ventilation or of an emergency stop <b>Note:</b> It may be connected to an external lamp as an option.
3	Green luminous pushbutton "Startup"	- Startup of installation and visual indication of startup. - Power-up of movements and atomizers.
4	General switch	- Power-up of all functions including functions not cut off by the Emergency Stop and the optional 400V/230V transformer.

The red "Fault" indicator light is activated according to the following conditions:

- External fault deactivated.
- Ventilation running deactivated.
- Powder level detector deactivated.
- External emergency stop inputs deactivated.

## Back side

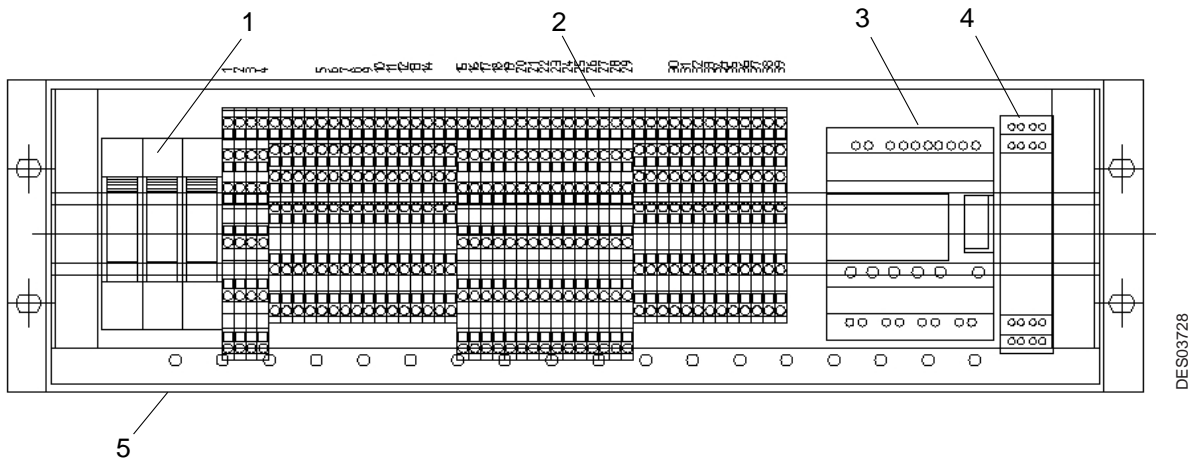

DES03728

Item	Description	Function
1	Main fuse holder	<ul style="list-style-type: none"> <li>- For electrical protection of the module by means of fuse cartridges.</li> <li>- General power supply input</li> </ul>
2	Connection terminal boxes	<ul style="list-style-type: none"> <li>- All electrical connections are made via this terminal box and according to the module's electrical diagram.</li> </ul>
3	Mini-PLC	<ul style="list-style-type: none"> <li>- In the absence of a REV control module, the mini-PLC can manage the spray on/off time-outs alone according to the detection function.</li> <li>Setting of spray on/off times according to the position of the "part present" sensor.</li> </ul>
4	Safety relay	<ul style="list-style-type: none"> <li>- Ensures "Emergency Stop" safety device.</li> </ul>
5	Fixing holes	<ul style="list-style-type: none"> <li>- Used to fix the cables to be connected to the terminals of the module by means of clamps.</li> <li>- Allows restoration of shielding.</li> </ul>



### 2.1.2. Presentation of pneumatic equipment

The pneumatic equipment is made of the set of pneumatic components described below and links.

Part Number: 900002783 (for 12 spraying modules).

900002784 (for 24 spraying modules).

#### 2.1.2.1. Synoptic of FCR cabinet pneumatic equipment

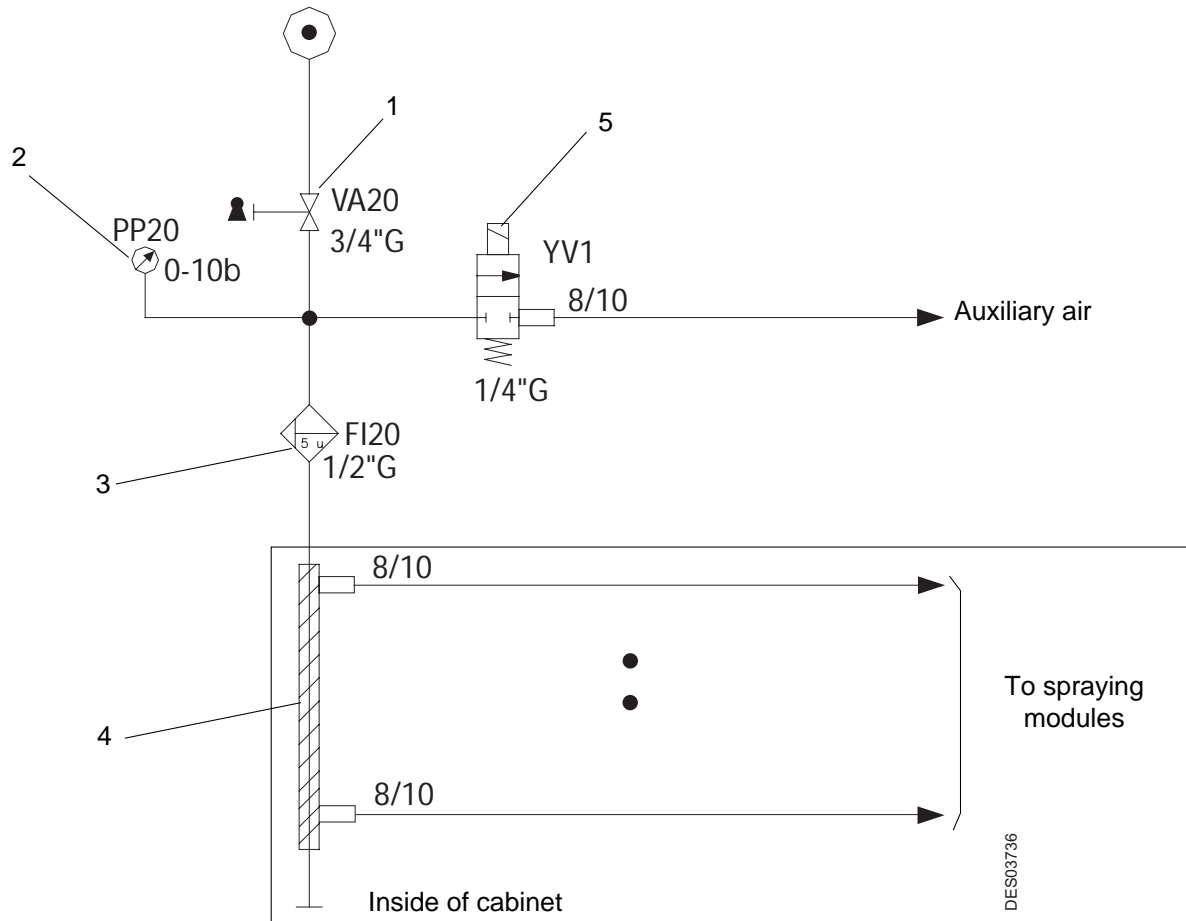

Item	Description	Function
1	Lockable general air valve	- Isolation of installation from pneumatic power supply.
2	General air pressure gauge	- Visual indication of presence and pressure of general air downstream of manual valve.
3	Air filter (5 $\mu$ m)	Ensures sufficient air quality for spraying modules.
4	Air distribution connector	- Air supply to spraying modules.
5	Auxiliary air solenoid valve	- Supply of a powder tank with air or other products.

2.1.2.2. Pneumatic synoptic for the spraying module connection

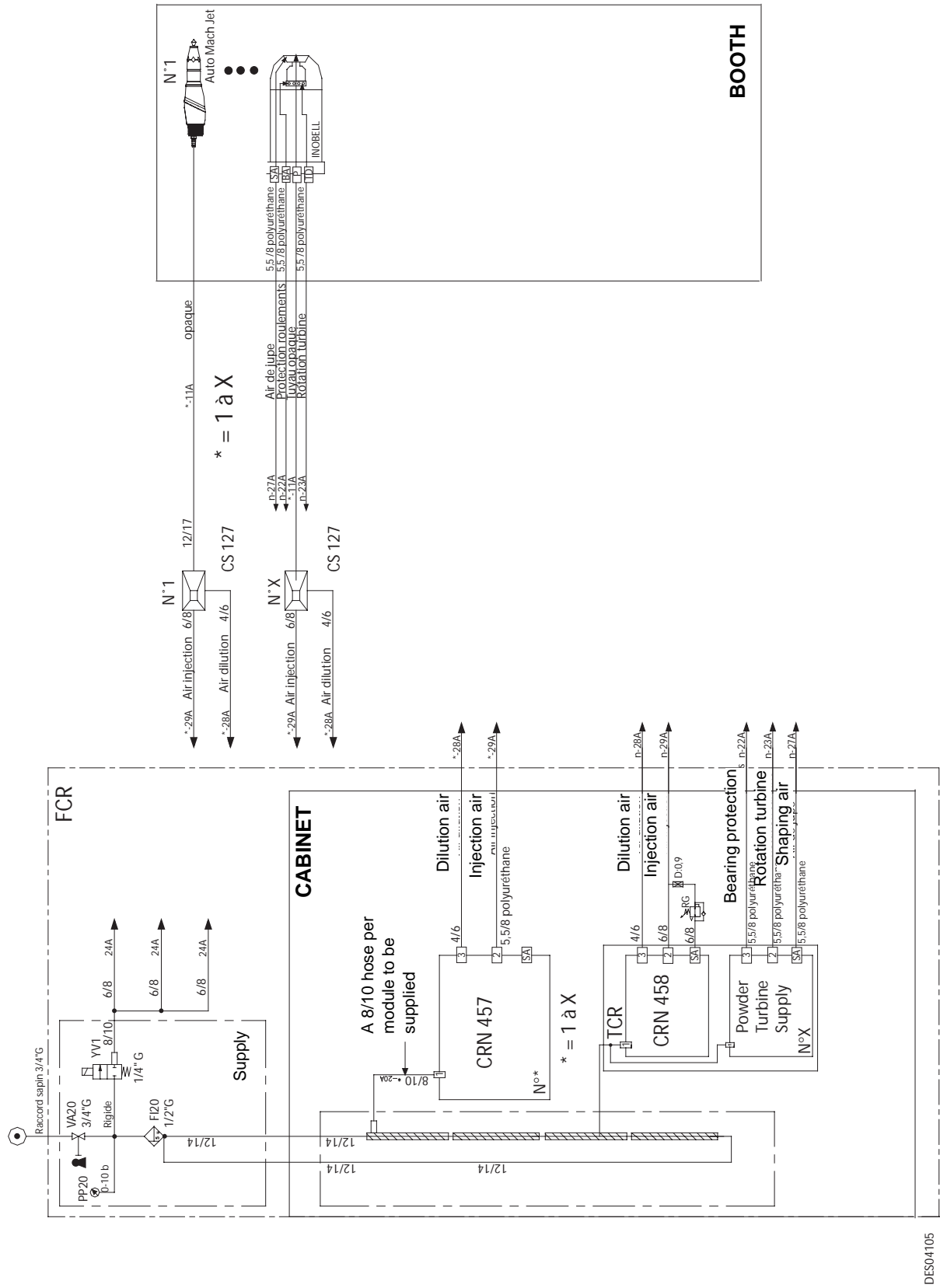

DES04105

2.1.2.3. Pneumatic synoptic for the connection of the auxiliary equipments

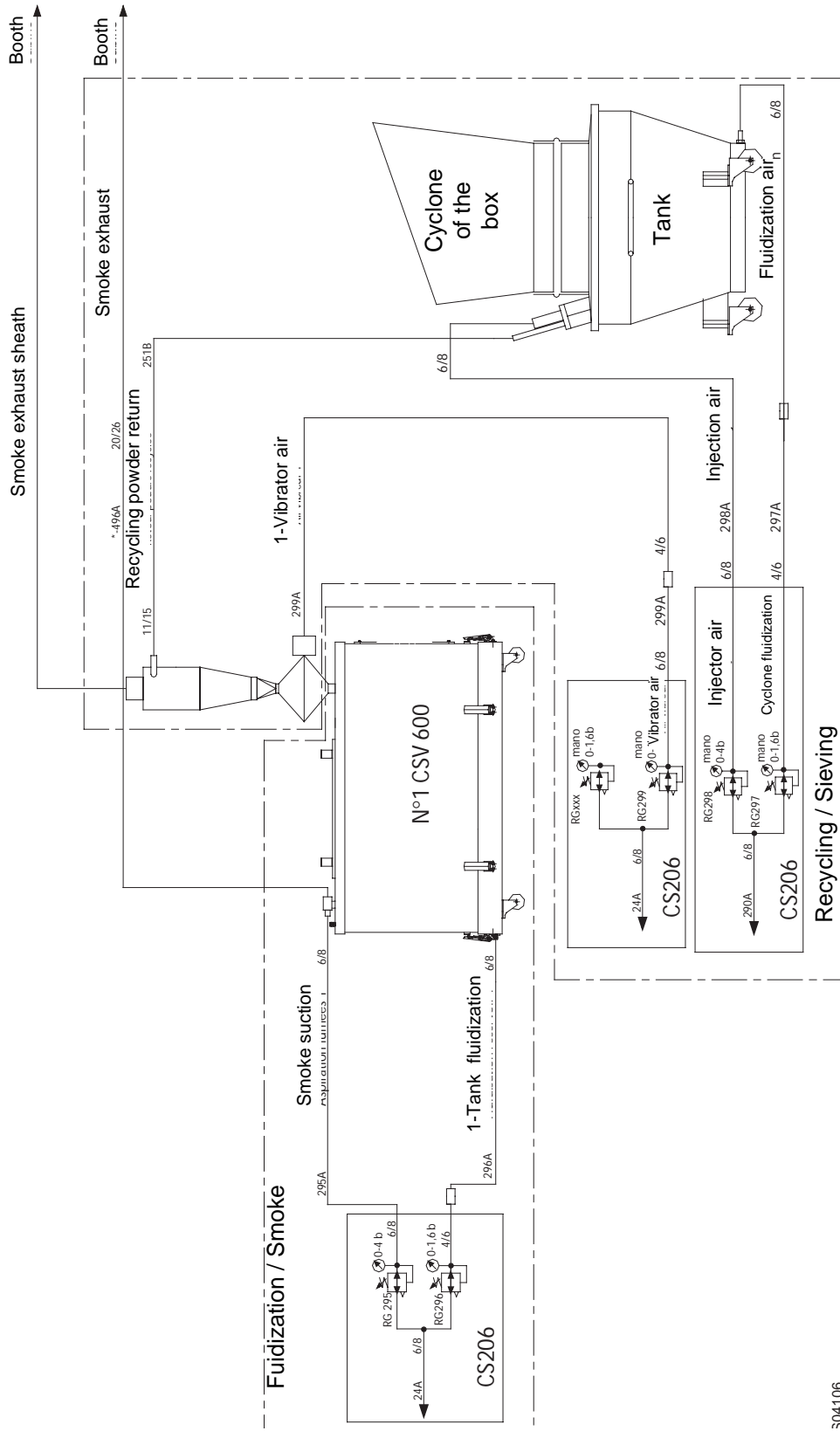

504106

## **2.2. Function**

The FCR cabinet manages the following functions:

- Twelve spray control devices managed simultaneously by a detection and time-out system.
- Electrical power supply to MCR and VCR modules (or up to two REV 600s).
- Electrical and pneumatic power supplies for 12 (low cabinet) to 24 (tall cabinet) control modules.
- Auxiliary pneumatic supply (e.g. for powder tank).
- Monitoring of low powder level in tank.

### 2.3. Block diagram of an installation

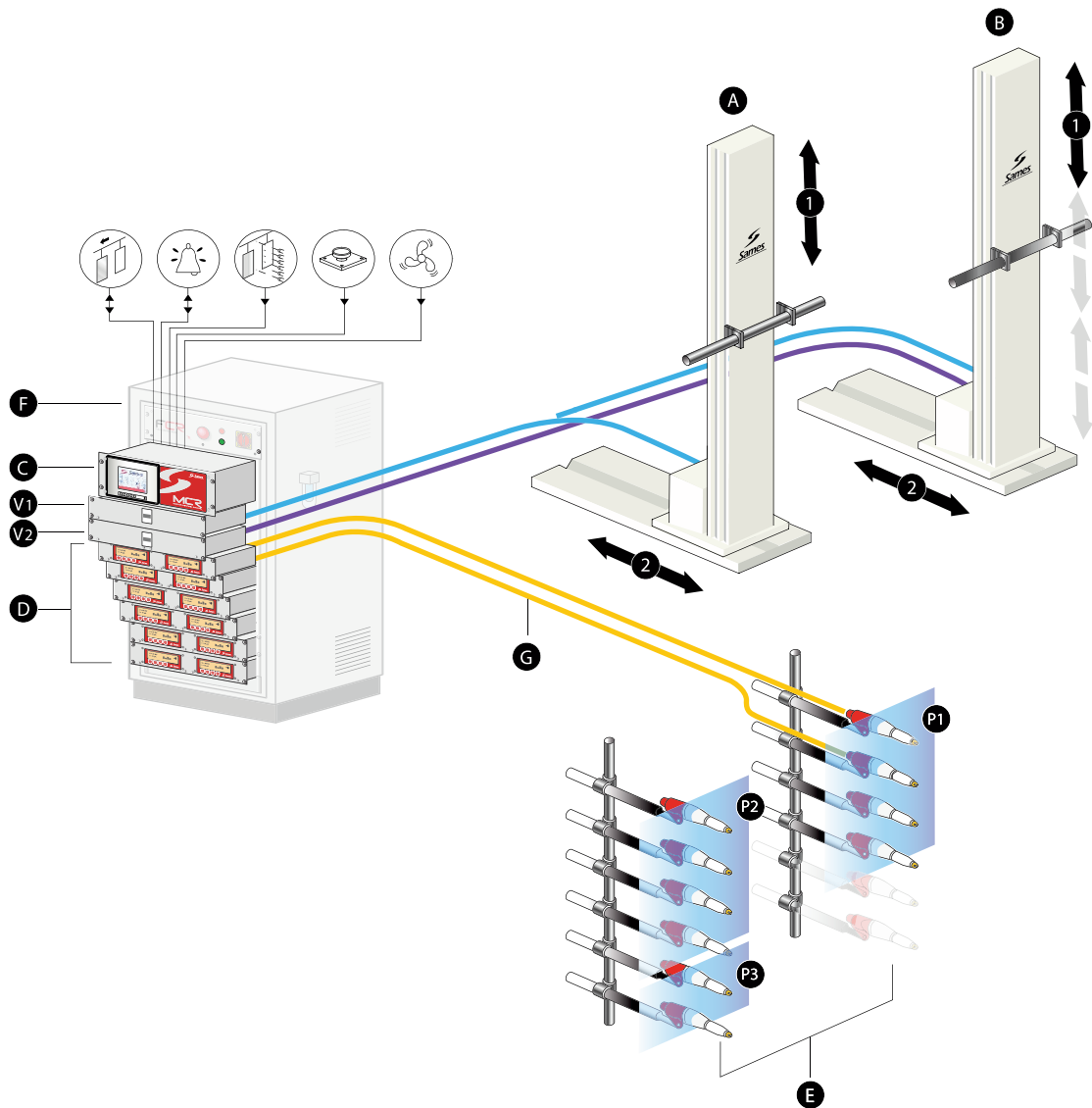

- |   |   |
|---|---|
| <ul style="list-style-type: none"> <li>Ⓐ First robot type RFV2000</li> <li>Ⓑ Second robot type RFV2000</li> <li>① Up and down movement</li> <li>② In and out movement (forward / backward)</li> <li>Ⓒ MCR or REV 600 Module</li> <li>Ⓓ CRN 457 or TCR Modules</li> <li>Ⓔ Maximum of 12 spray guns per robot</li> <li>Ⓕ FCR modular cabinet</li> <li>Ⓖ Trigger ON/OFF pilot</li> </ul> | <ul style="list-style-type: none"> <li>⒱ VCR Module (management of up 2 axes)</li> <li>⒲ VCR Module (management of up 4 axes)</li> <li>Ⓖ→Ⓖ Example of spraying planes</li> <li>Ⓖ→Ⓖ Input / Output conveyor operation and authorization</li> <li>Ⓖ→Ⓖ Input / Output external fault</li> <li>Ⓖ→Ⓖ Input - part Détection</li> <li>Ⓖ→Ⓖ Input - Emergency stop</li> <li>Ⓖ→Ⓖ Input - Ventilation operation</li> </ul> |
|---|---|

DES04539

### 3. Technical characteristics

#### 3.1. General characteristics

##### 3.1.1. FCR cabinet

Height	Low model 1,200 mm (+ 100 mm for base) Tall model 2,000 mm (+ 100 mm for base)
Width	600 mm
Depth	600 mm
Colour	RAL 7035
Seals	IP 20
Empty weight	65 kg low model 87.5 kg tall model.

##### 3.1.2. Electrical power supply module

Height	132.5 mm (3 U)
Width	483 mm (Rackable, 19 inch units)
Seals	IP 20

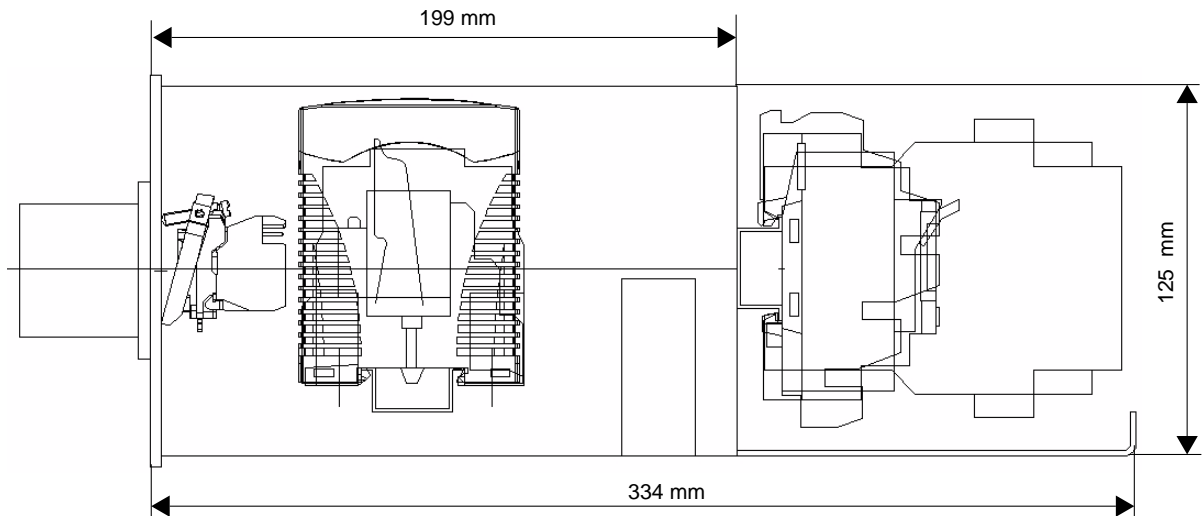

### 3.2. Electrical characteristics

#### 3.2.1. FCR cabinet

The main electrical power supply is located at the back of the electrical power supply module at the top of the FCR cabinet and has the following characteristics:

Power-supply voltage	Single or Three-phase 230V AC + ground
Input frequency range	50 - 60 Hz
Max. input current consumed	16 A
Maximum cross section of conductor wires	4 mm <sup>2</sup>
Values of fuses in general isolating switch Q1	16AaM



**WARNING: A transformer kit is available for a Three-phase 400V + ground power supply. A three-phase power supply is compulsory if there is one transformer.**

The power supply cable is inserted either through the top or by the bottom (base) of the cabinet. Cable-gland plates with brushes are installed on these faces. In both cases, the supply is done on the back of the panel.

The power supply cable is connected to the top of the general isolating switch for the three phases and to one of the ground terminals for the green/yellow wire.

#### 3.2.2. Electrical power supply module

"CRN 457" or "TCR" electrical spraying module supply (24 max.)and power module (2 robot axles maxi)	230V AC Single phase, Max apparent power 3.7 kVA
"CRN 457" or "TCR" electrical spraying module supply (24 max.)and power module (4 robot axles maxi)	230V AC Three phase, Max apparent power 6.4 kVA
1 category 3 emergency stop device (with 1 spare)	
1 spare input (dry contact) for remote shutdown of the installation	
Trigger control	12, simultaneous with one "lack of parts" detection device + 1 time-out system (used in absence of a REV control module).
Lack of powder fault	Operates with 1 level detector (3 wires, 24V DC)
Fault display by indicator light (external faults, low powder level) or external lamp (option)	

#### Information exchange:

Customer -> Sames Installation

- "Conveyor running," 1 NO (normally open) dry contact (used in absence of REV or MCR).
- "Booth ventilation running," 1 NO dry contact (used in absence of REV or MCR).
- "External faults," 1 NO dry contact

Sames Installation -> Customer

- "Conveyor Authorisation," 1 NO dry contact (used in absence of REV or MCR).

### 3.3. Pneumatic characteristics

A general air inlet installed on an outside face (right or left) of the FCR cabinet must have the following characteristics:

Connection (*)	3/4" barbed fitting for air hose
Input pressure	7 bar +/-0.5 bar
Maximum flow rate	190 Nm <sup>3</sup> /h
Maximum auxiliary air consumption	30 Nm <sup>3</sup> /h
Maximum consumption by CRN457	6 Nm <sup>3</sup> /h
Maximum consumption by TCR	20 Nm <sup>3</sup> /h
<b>General air characteristics according to standard (NF ISO 8573-1)</b>	
Maximum solid impurity content	5 mg/m <sub>0</sub> <sup>3</sup> (class 3)**
Maximum size of solid impurities	5 μm (class 3)
Maximum oil content	0.01 mg/ m <sub>0</sub> <sup>3</sup> (class 1)
Dew point at 6 bar (87 psi)	3° C (37°F) (class 4)

**(\*): The barbed fitting is located upstream of the manual valve.**

The pneumatic connections for machine functions are made through the bottom of the cabinet via the base.

The auxiliary pneumatic connection is made on the outside, at the solenoid valve outlet.

**(\*\*)** Values given for a temperature of 20°C (68°F) and an atmospheric pressure of 1,013 mbar.

#### Maximum number of spraying modules supported by the FCR cabinet:

- 8 -TCR modules
- 6 -TCR modules + 6-CRN 457 modules
- 4 -TCR modules + 12-CRN 457 modules
- 2-TCR modules + 20-CRN 457 modules
- 24-CRN 457 modules

### 3.4. 24V DC power supply characteristics

Output voltage	24V DC
Tolerance	+/- 1%
Maximum capacity	1.3 A
Power	30 W
Efficiency	84%



### 3.5. Characteristics of Input/Output interfacing with the outside

<b>“On-Off” input characteristics</b>				
<b>Module type</b>				
Nominal input value	Voltage		V	24
	Current		mA	
Input switching limit value	In state 1	Voltage	V	15
		Current	mA	2.20
	In state 0	Voltage	V	≤ 5
		Current	mA	< 0.75
Input impedance in state 1			KΩ	7.4
Compliance IEC/EN 61131-2				Type 1
Sensor compatibility	3 wires			PNP Yes
	2 wires			No
Input type				Resistive
Insulation	Between power supply and inputs			None
	Between inputs			None
Max. counting frequency			kHz	1
Protection	Against terminal inversions			No acknowledgement of command
<b>Characteristics of outputs with relays (Conveyor authorisation)</b>				
<b>Module type</b>				
Use limit value			V	5 ... 150 (direct) 24 ... 250 (alternating)
Contact type				On closing
Thermal current			A	8
Electrical durability for 500,000 manoeuvres	Use category	DC-12	V	24
			A	1.5
		DC-13	V	24 (L/R = 10 ms)
			A	0.6
		AC-12	V	230
			A	1.5
		AC-15	V	230
			A	0.9
Minimum switching current	With a minimum voltage of 12V		mA	10
Contact reliability at low level				12 V -10 mA
Maximum operating rate	When empty		Hz	10
	At use current		Hz	0.1
Mechanical lifetime	In millions of manoeuvre cycles			10
Voltage assigned to shock resistance	According to IEC/EN 60947-1 and IEC/EN 60664-1		kV	4
Response time	Engagement		ms	10
	Disengagement		ms	5
Built-in protection devices	Against short circuits			None
	Against voltage surges and overloads			None

## **4. Installation**

- 1 The cabinet must be installed on the ground, levelled horizontally and fixed solidly.
- 2 It must not be placed against a wall (back side opens to give access to connections). The recommended distance is 1 metre.
- 3 It can be placed with its left or right side against a wall if the general air inlet is installed on the opposite one.  
A distance of at least 250 mm must be left if the air supply is on the same side as the wall.

### **4.1. Connection of control modules**

Connection of the modules to the outside of the cabinet can be done either by the top or by the bottom (via the base). Cable-gland plates with brushes are installed on these faces. In both cases, the supply is done on the back of the panel.

Atomizers and robots are connected directly to the back of the modules in question via the base (access via the opening rear panel).

## 5. Installation startup and shutdown procedures

### 5.1. Startup procedures

#### 5.1.1. Power-up

- Close the general switch located at the top right-hand side of the front panel.  
The MCR or REV 600 control module lights up, if installed.

#### 5.1.2. Pressurisation

- Open the manual general air valve  
The general air pressure gauge indicates network pressure.

#### 5.1.3. Booth startup

- Check that the “Emergency Stop” pushbutton(s) are not engaged and that the booth door(s) are closed.
- Press the luminous green “ON” pushbutton.  
The indicator light lights up, the spraying modules light up, the movements are powered up and the auxiliary air solenoid valve opens.

After the startup procedure has been carried out, the station is ready to be used.

### 5.2. Shutdown procedures

#### 5.2.1. Switching off

- Press the “Emergency Stop” pushbutton.  
The luminous green “ON” pushbutton switches off.  
The spraying modules switch off, the power supply to the movements is cut off and the auxiliary air solenoid valve closes.

**Remark: The station can be switched off at the end of production, for example.**

#### 5.2.2. Power-down

- Open the general switch located at the top right-hand side of the front panel.  
The MCR or REV 600 control module switches off, if installed.

#### 5.2.3. Depressurisation

- Close the manual general air valve  
The general air pressure gauge indicates zero pressure.

**Remark: The station can be switched off and depressurised (lock-out of energy sources) for a maintenance operation, for example.**

## 6. Adjustments

**Accessible via the panel on the back of the cabinet.**

When the control module is not installed, the power-supply module can manage the spray on/off time-outs according to the detection distance.

The Zelio mini-PLC is configured by default as follows:

- Time-out for spraying delay after detection T1 = 05 seconds.
- Time-out before spraying cut-off after detection T2 = 15 seconds.
- Time-out before cut-off between parts T3 = 15 sec
- Time-out for delay on emergency stop T4 = 15 sec
- Time-out for uninterrupted spraying T5 = 10 sec.

Values T1 and T5 can be configured from 0 to 999 seconds.

To have a permanent spraying, it is necessary to strap the detection output to the 24 VDC.

**T1 Spraying delay time-out:** When the first part in a series is detected, triggering of spraying is delayed to await arrival of the part in front of the robot.

This avoids spraying directly after detection and thus reduces paint or powder consumption.

Setting:

The time-out must be set according to conveyor speed and the distance between detection of parts and the position of the robot.

The value is common to all spraying modules connected to the FCR cabinet.

**T2 Time-out for spraying cut-off after detection:** After the last part in a series on the first not-detection, spraying cut-off is delayed to allow completion of application on the parts.

Settings:

The time-out must be set according to conveyor speed and the distance between detection of parts and the position of the robot.

The value is common to all spraying modules connected to the FCR cabinet.

**T3 Time-out before cut-off between parts :** This time-out makes it possible to extend spraying during a new detection of part. This value must be equal to T2.

Setting: the same as T2 Time-out.

The value is common to all spraying modules connected to the FCR cabinet.

**T4 Time-out for delay on conveyor stop:** After an conveyor stop, the spraying will be forced with this value at the conveyor restarting so as not to lose the part to be powdered.

Setting: the same as T2 Time-out.

The value is common to all spraying modules connected to the FCR cabinet.

**T5 Time-out for uninterrupted spraying:** This time-out makes it possible to differentiate an interrupted spraying from a long part at the time of detection. If detection input is validated during a time upper to T5, then the system considers that the detection is uninterrupted.

The value is common to all spraying modules connected to the FCR cabinet.

**T6 Time-out of trigger:** This time-out makes it possible to delay spraying after an emergency stop to await the conveyor restarting (time of start-up of the conveyor or of the installation).

The value is common to all spraying modules connected to the FCR cabinet.

## 6.1. Front side of mini-PLC

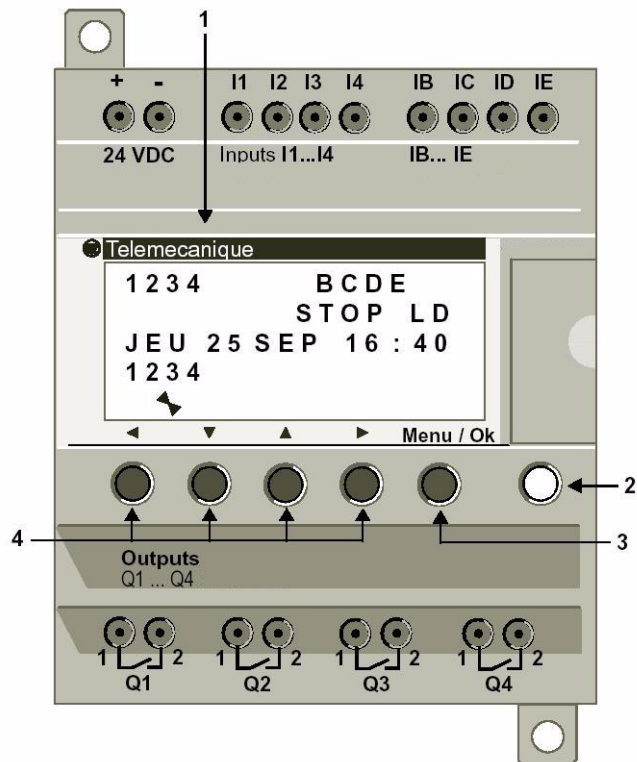

Item	Description
1	LCD display, 4 lines, 18 characters
2	Shift key
3	Selection and validation key
4	Keys for navigation or following configuration of Z pushbuttons

## 6.2. LCD display

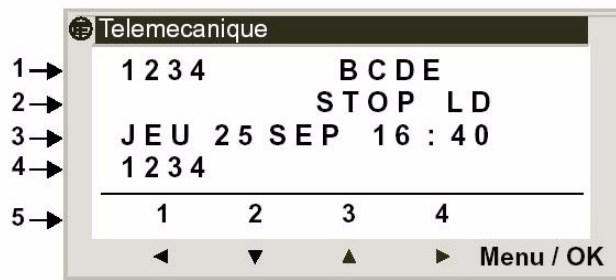

Item	Description
1	Display of input states
2	Display of run mode (Run/Stop) and programming mode (LD/FBD)
3	Display of date (day and time for products equipped with a clock)
4	Display of output states
5	Contextual menus / pushbuttons / icons indicating run modes

### 6.2.1. Setting parameters



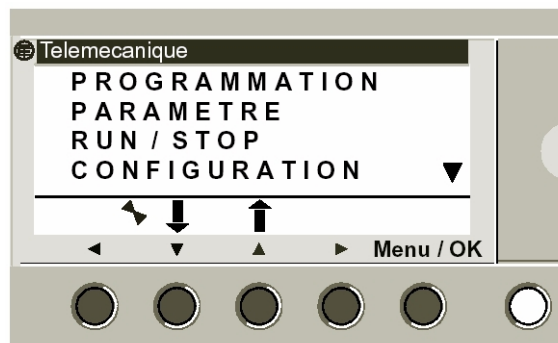

- **Step 1:** Press "Menu OK" key.
- **Step 2:** Press arrow keys  and  to move on the "PARAMETER" line.

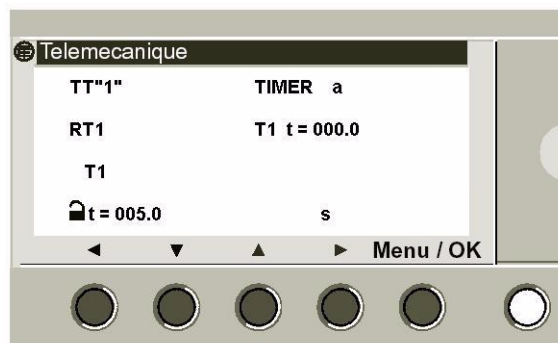

- **Step 3:** Go to the "PARAMETER" menu by pressing the "Menu OK" key.



The figure "1" flashes on the first line.



- **Step 4:** To change the value of time-out T1, select the T1 value with the keys  and . The value "005.0" flashes.
- **Step 5:** Adjust the time in seconds with the key  to increase and with the key  to reduce the value.
- **Step 6:** Once the value has been changed, validate the new value by pressing the "Menu OK" key.



The choice "Yes" flashes.

Press the "Menu OK" key to confirm the choice.

The new value is now taken into account.

- **Step 7:** To modify another parameter, press the keys  and  to select it.

Repeat steps 4 to 7 to change parameters T2 to T5.

- **Step 8:** To return to the main menu, press the "Menu OK" key after step 7.

## 7. Connection

### 7.1. General

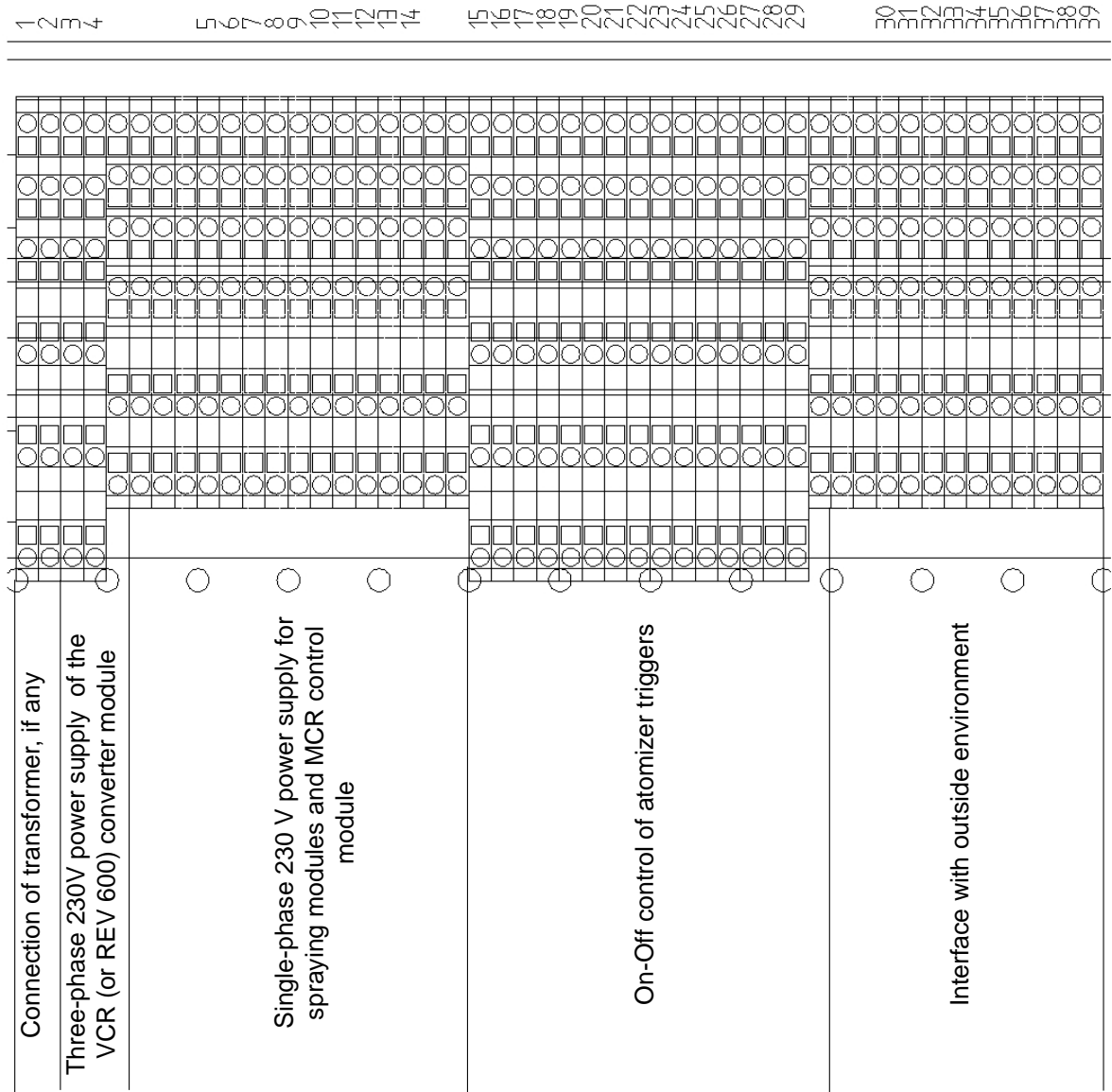

It is equipped with double-spring or triple-stage terminals. The presence of end-pieces on the flexible wires is unnecessary.



**7.2. Correspondence between the terminal box and the electrical diagram**  
**Triple terminals**

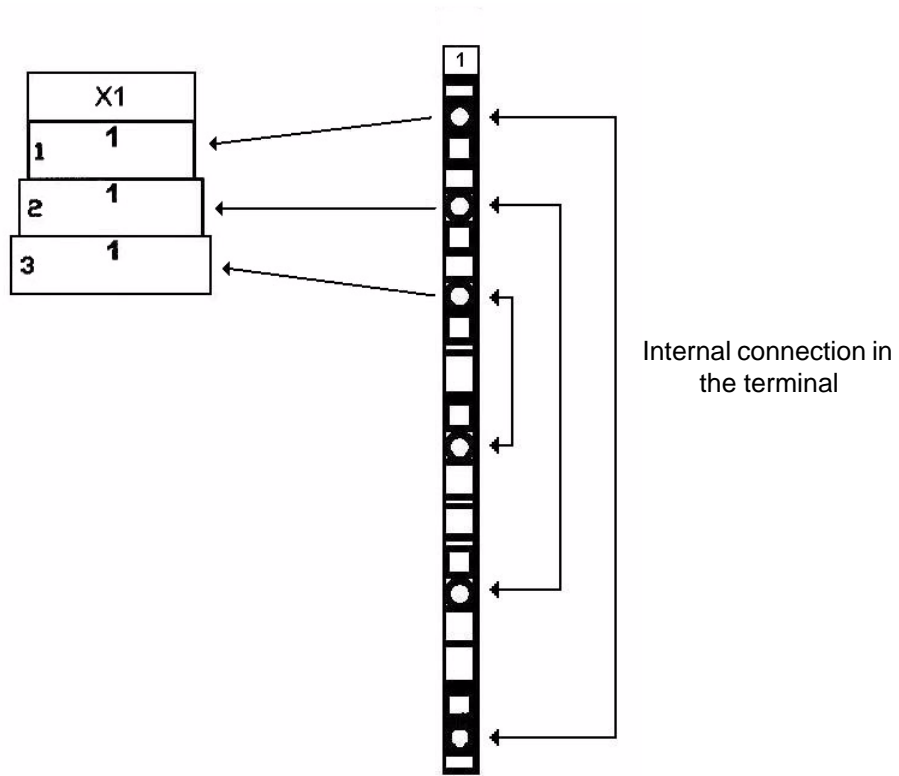

**Double terminals**

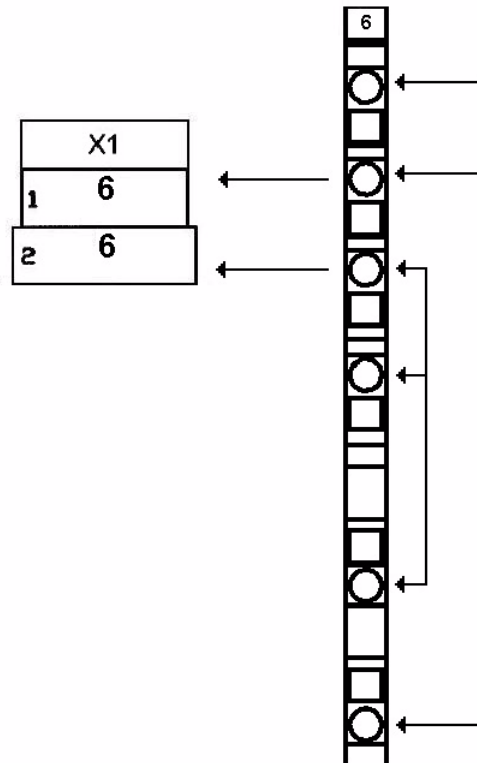

### 7.3. Ground Connection



**WARNING:** This equipment must be connected to the ground otherwise it may generate dangerous conditions.

The Green/Yellow wire in the power supply cable must be connected to the brass screw on the back left-hand side of the module.

The diameter of the Green / yellow wire must at least be equal to the diameter of the wires of supply.

### 7.4. Connection of module supply voltage Single-phase 230 V power supply

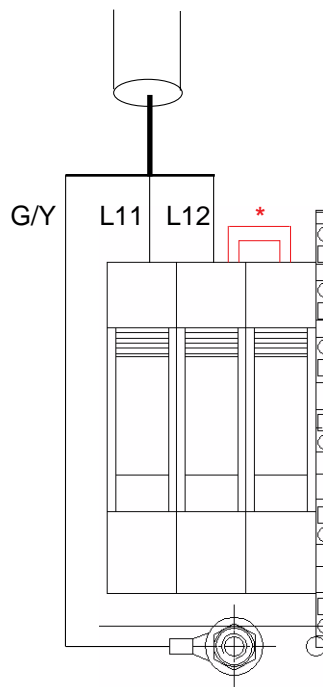

The cable recommended by Sames Technologies is 3 G 1.5 mm<sup>2</sup> (Ref.: E2CCKN004).

\*: In Single-phase 230 V power supply, the bridge mut remain installed.



**WARNING:** In Single-phase 230 V power supply, the FCR cabinet will be able to supply maximum two robot axes.

The electric connection of the FCR cabinet is not compatible with the use of a plug equipped with a 30 mA differential.

## Three-phase 400/230V power supply

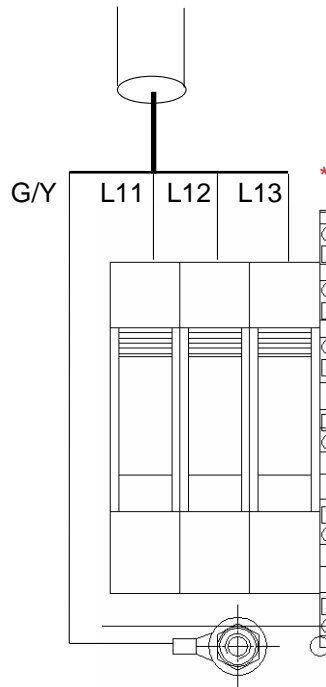

The cable recommended by Sames Technologies is 4 G 2.5 mm<sup>2</sup> (Ref.: E2CDKR005).



**WARNING:** In the case of a 400V power supply, the 400/230V transformer kit is compulsory on pain of seriously damaging the modules.

\*: In Three-phase 400/230V power supply, the bridge must be removed.



**WARNING:** In Three-phase 400/230V power supply, the FCR cabinet will be able to supply to 4 robot axles.

## 7.5. Connection of 400/230V transformer

Terminals 1 and 2 are dedicated to connection of a three-phase 400/230V transformer, if one is installed. **Without transformer** (230 V three-phase or single phase power supply only): this is the default configuration. The three bridges between the terminals dispense with the need for a transformer and ensure voltage continuity.

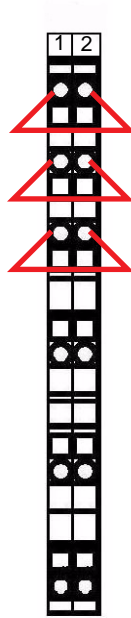

With transformer (400V three-phase power supply only)

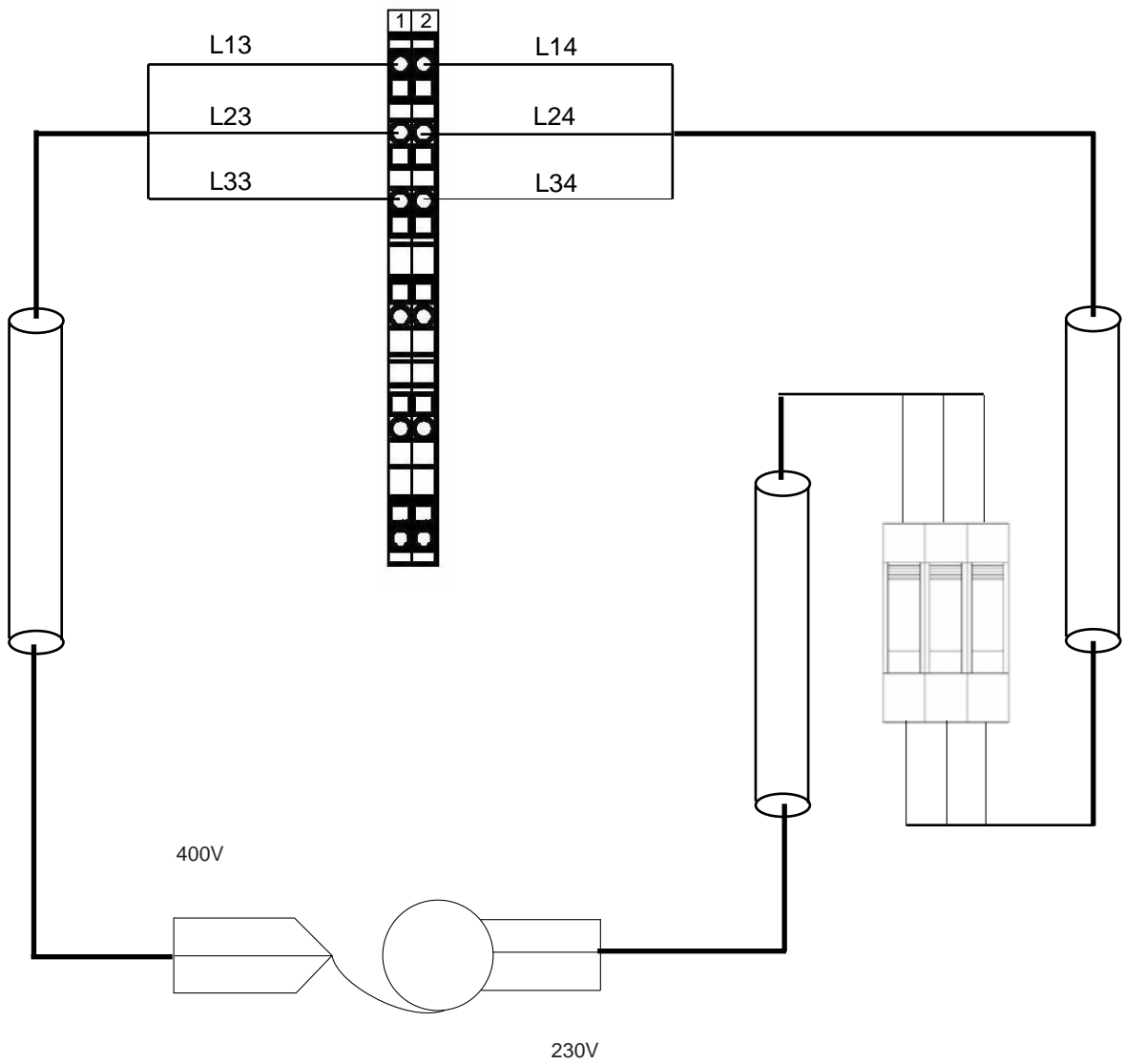

**7.6. Connection of VCR converter modules or REV 600 modules**

Terminals 3 and 4 are dedicated to VCR converter module (or REV 600 modules) power supply.

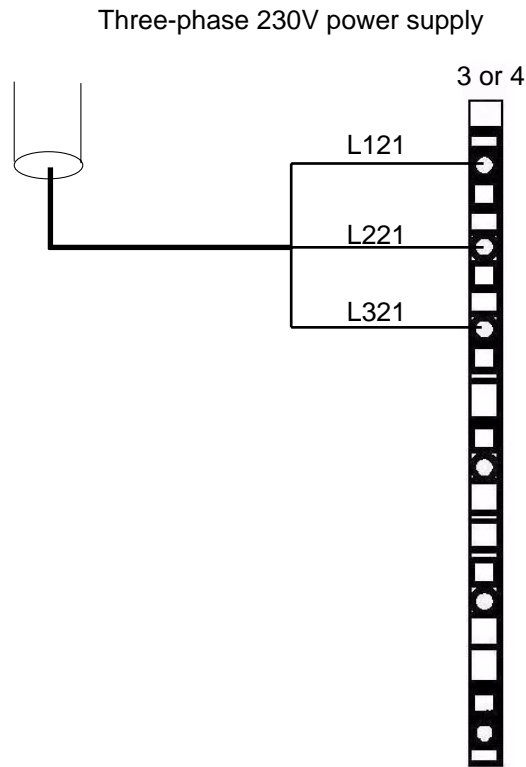

The REV 600 can be supplied with three-phase power in the same way as for connection of the converter module in three-phase but its automatic control system is switched off on an “emergency stop,” thus, it is necessary to wait for its re-initialisation after reset before being able to work.

**7.7. Connection of MCR control module**  
Single-phase 230V power supply

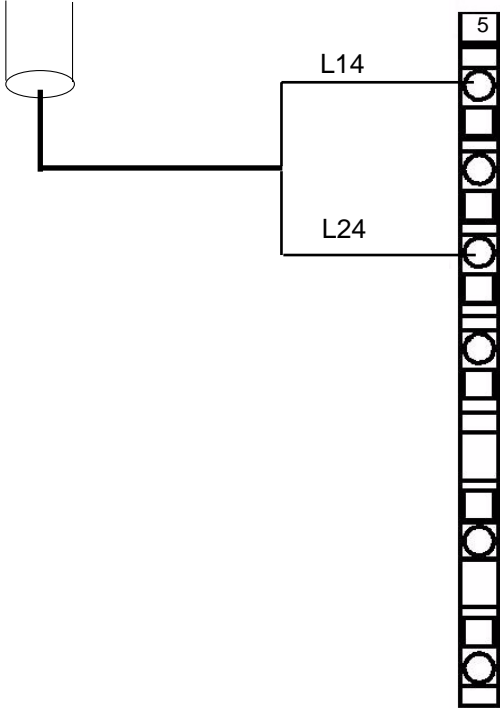

## 7.8. Connection of spraying modules

### 7.8.1. CRN 457 control module

**Electrical power supply:** CRN 457 module

Terminals 6 to 14 are dedicated to the power supply CRN 457 modules. One terminal can supply up to three CRN 457 modules.

Single-phase 230V power supply

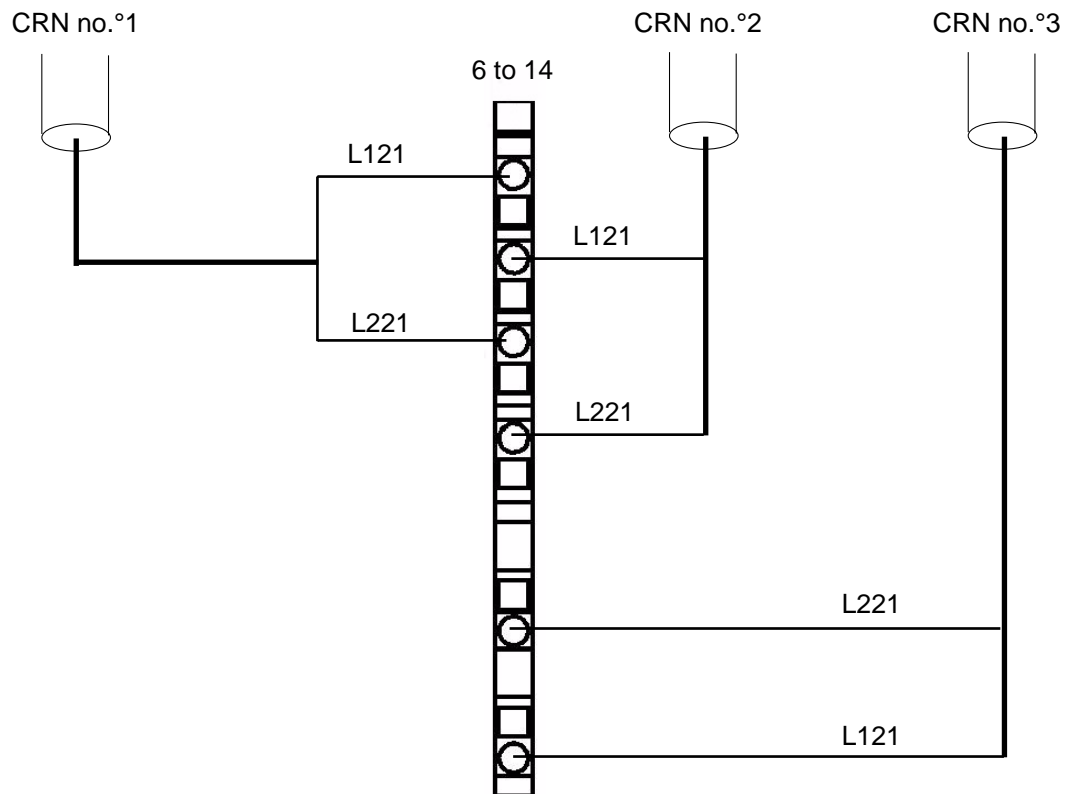



### Trigger control - CRN 457 module

Terminals 15 to 26 are dedicated to control of spraying modules.

CRN 457 triggers are controlled by the presence or absence of the 24V power supply (wires no.° 28).

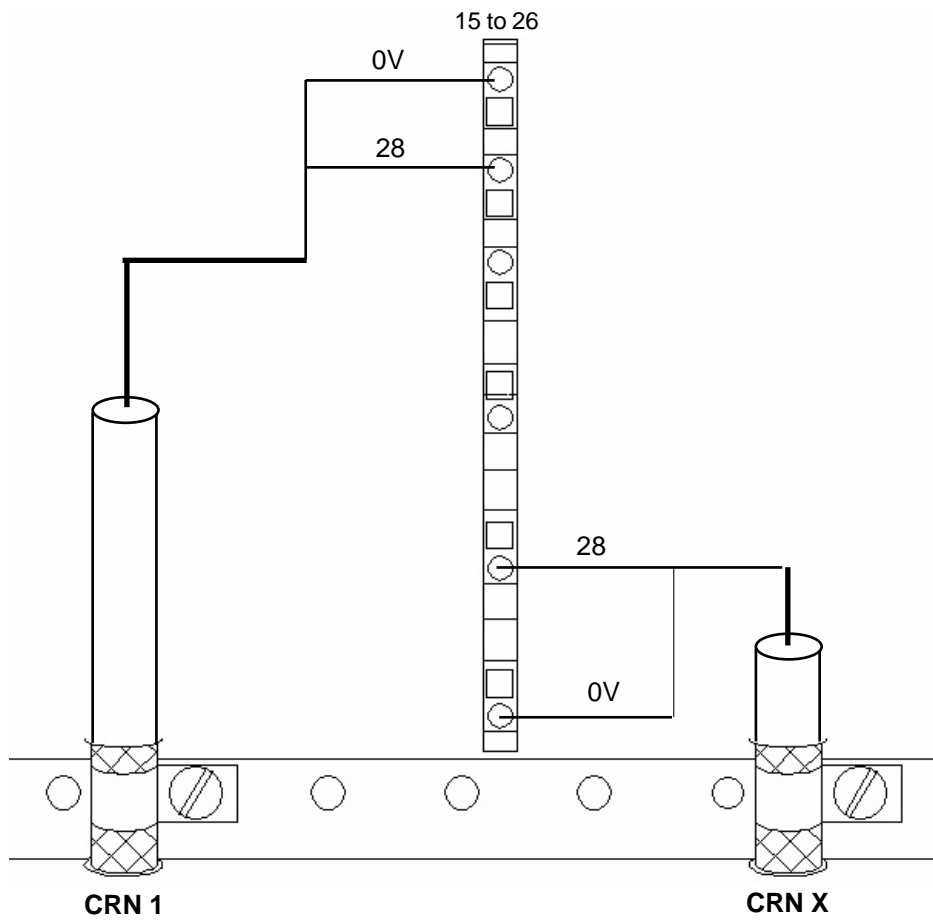

Terminals 15 - 26 manage the triggers of the various atomizers Sames, each of these twelve terminals manages two triggers, that is 24 triggers all in all. The wire 0V indicates the common and the wire 28 represents the trigger 24V.

7.8.2. TCR control module

**Electrical power supply - TCR Module**

Terminals 6 to 14 are dedicated to the power supply of the TCR modules. One terminal can supply one TCR module.

Single-phase 230V power supply

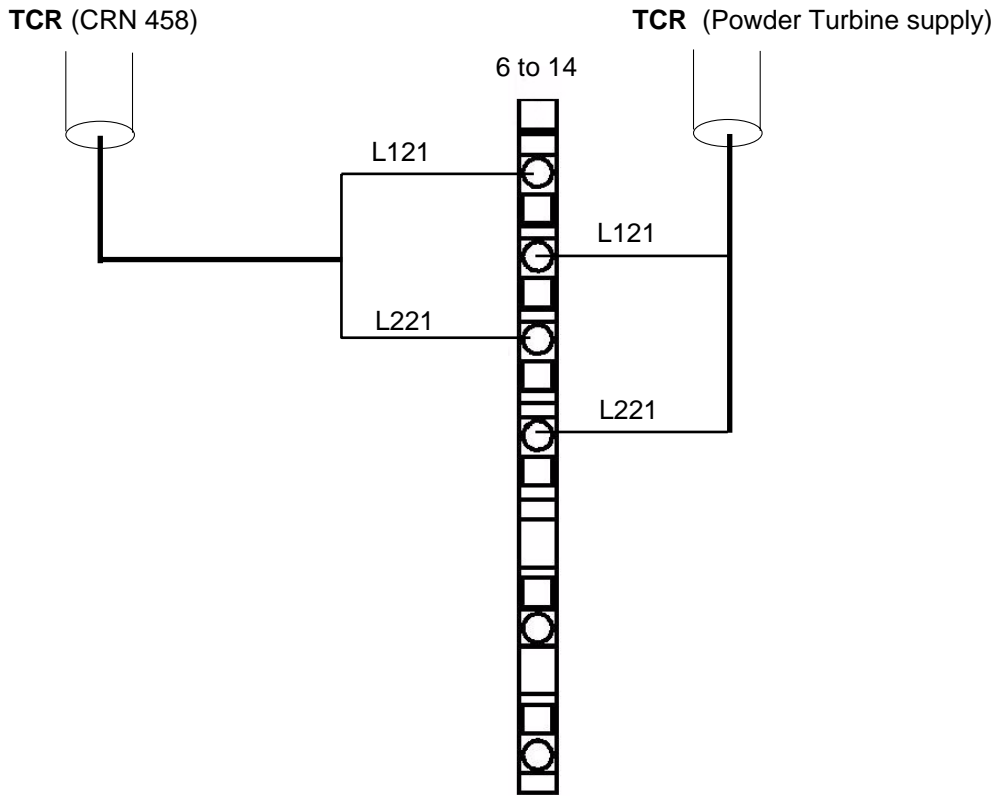

## Trigger control - TCR module

Terminals 15 to 26 are dedicated to control of spraying modules.

TCR triggers are controlled by the presence or absence of the 0V power supply (wires no. 33 to 44).

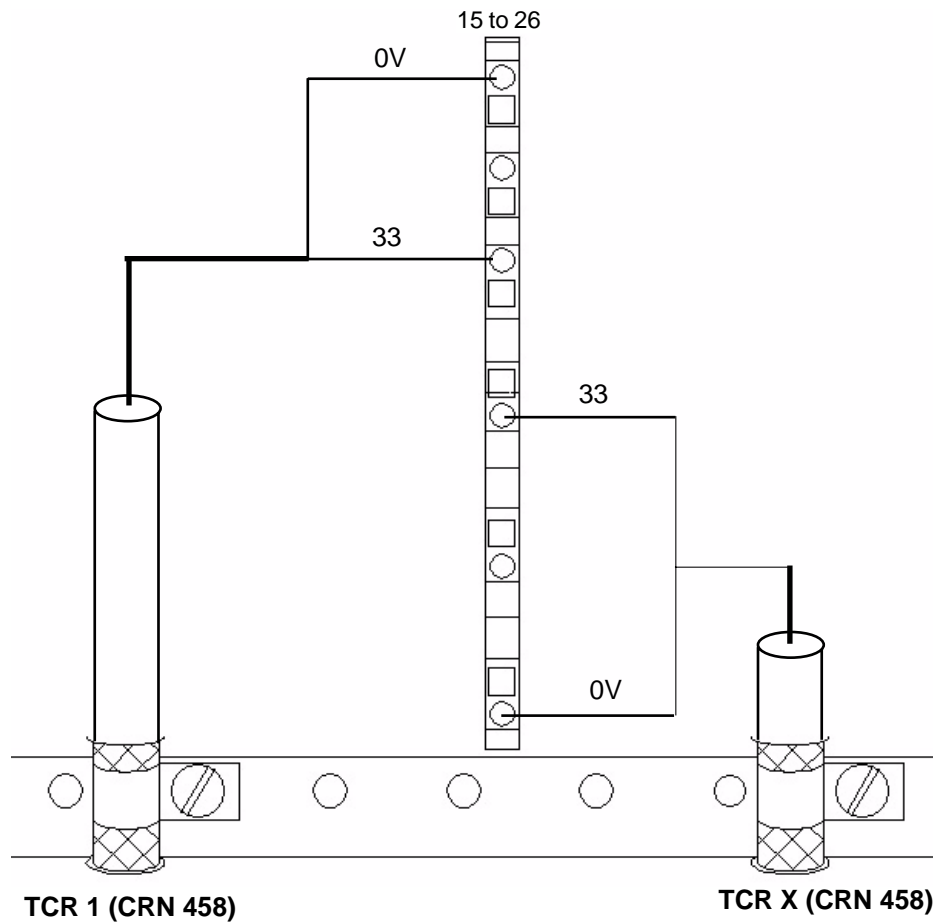

The wire 0V indicates the common and the wire 33 represents the trigger 0V.

### Remarks:

To be able to pilot the triggers of TCR modules , the rotation of the turbine must be effective ([see RT Nr 7062](#)).

It is necessary for it to configure the parameter " local HT " in 0 and "Turb Local" in 1 may activate the rotation of the turbine on every TCR module.

7.8.3. TRJ 102 control module

**Electrical power supply - TRJ 102 Module**

Terminals 6 to 14 are dedicated to the power supply of the TRJ 102 modules. One terminal can supply up to three TRJ 102 modules.

Single-phase 230V power supply

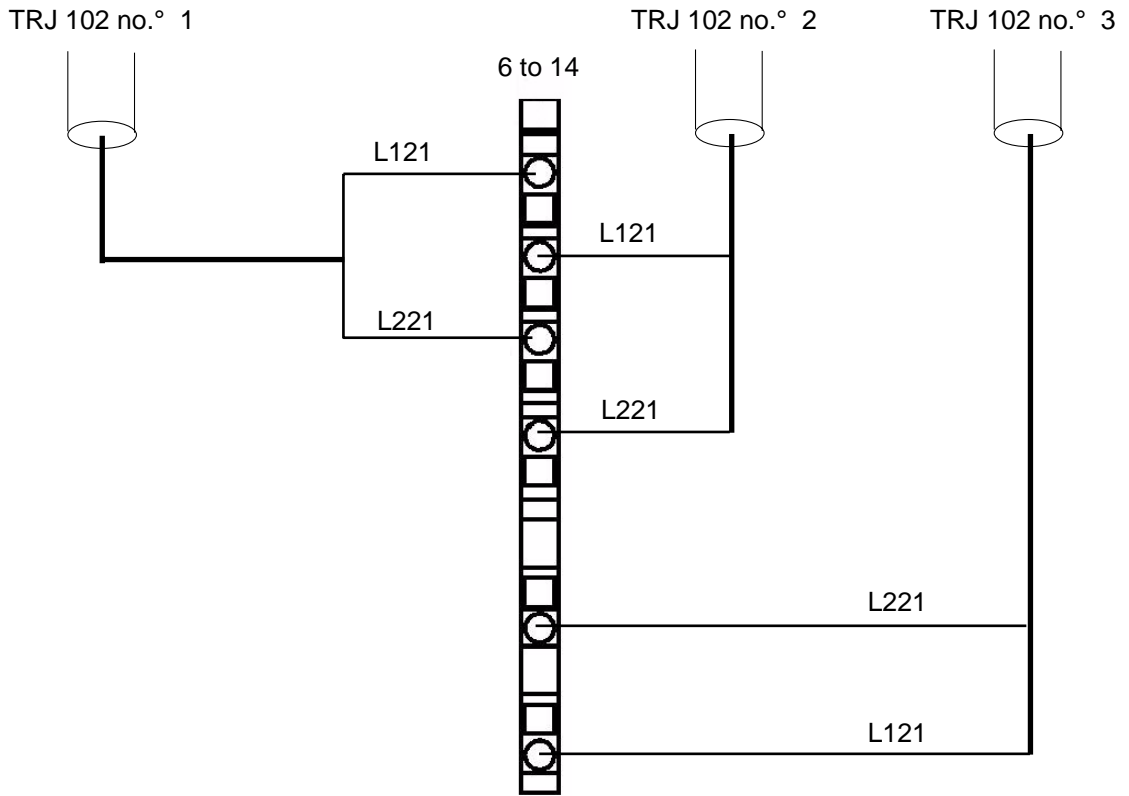

### Trigger control - TRJ 102 module

TRJ 102 triggers are controlled by the presence or absence of the 0V power supply.

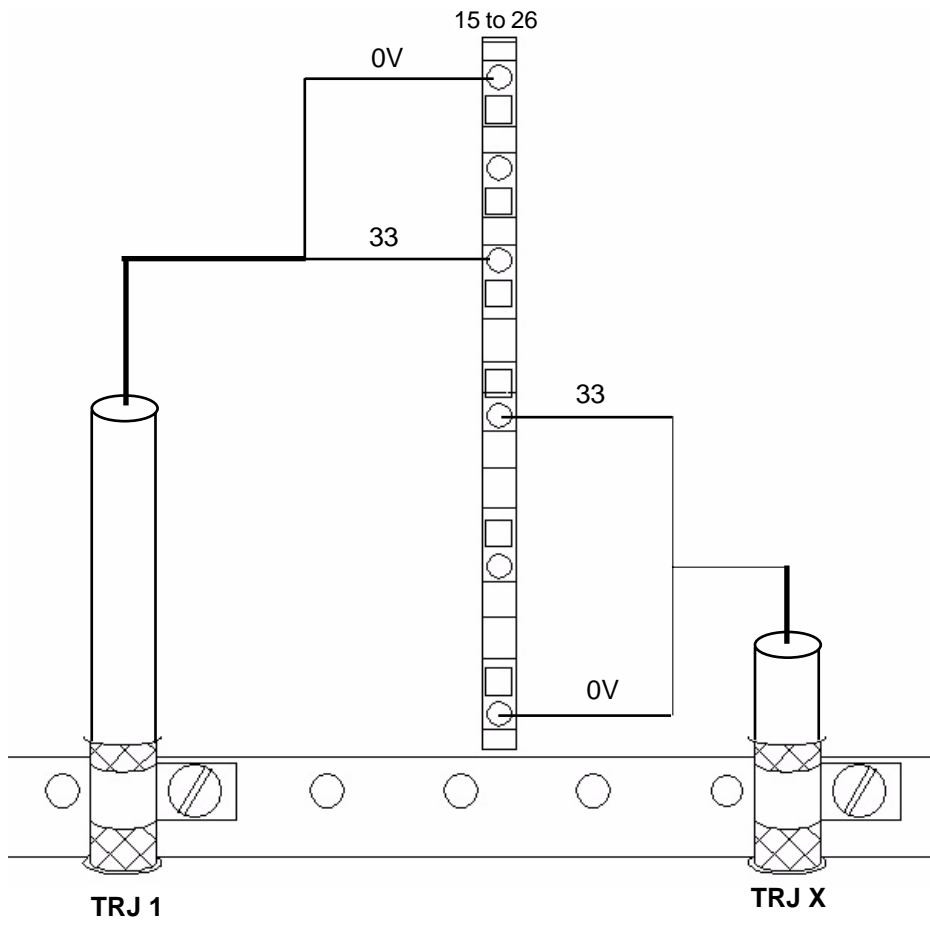

## 7.9. Connection of interfaces with the outside

### 7.9.1. Part detection

#### By barrier cell

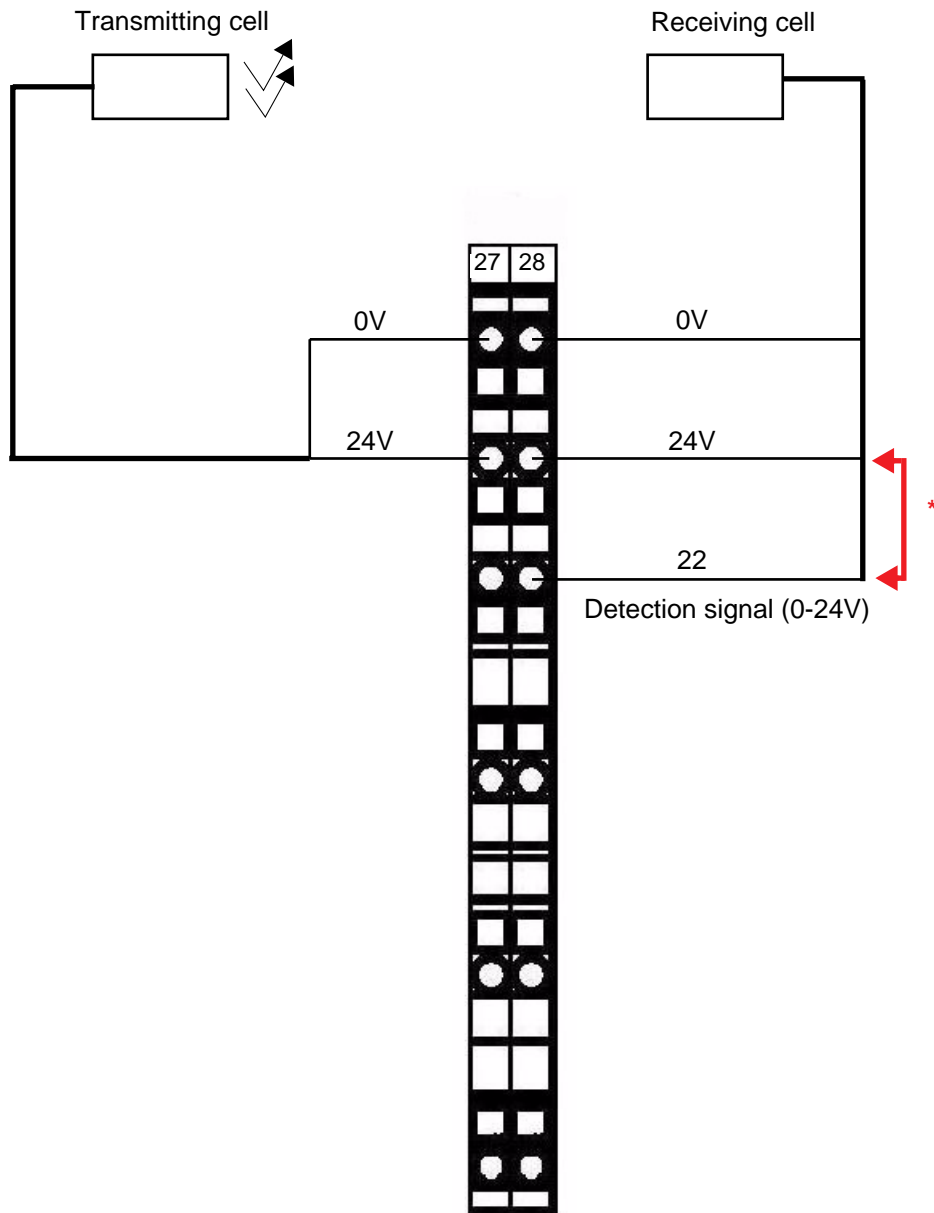

\*: bridging to be installed if detection input is not used.  
Except if the TCR modules are installed in the cabinet.



**WARNING:** Indeed, the uninterrupted spraying (forced detection) should not be only engaged when the turbines of the FCR modules are in established mode.  
The turbines of the TCR modules must be manually started on the module, then the spraying (uninterrupted detection or automatic) can be used.

**By mechanical position sensor**

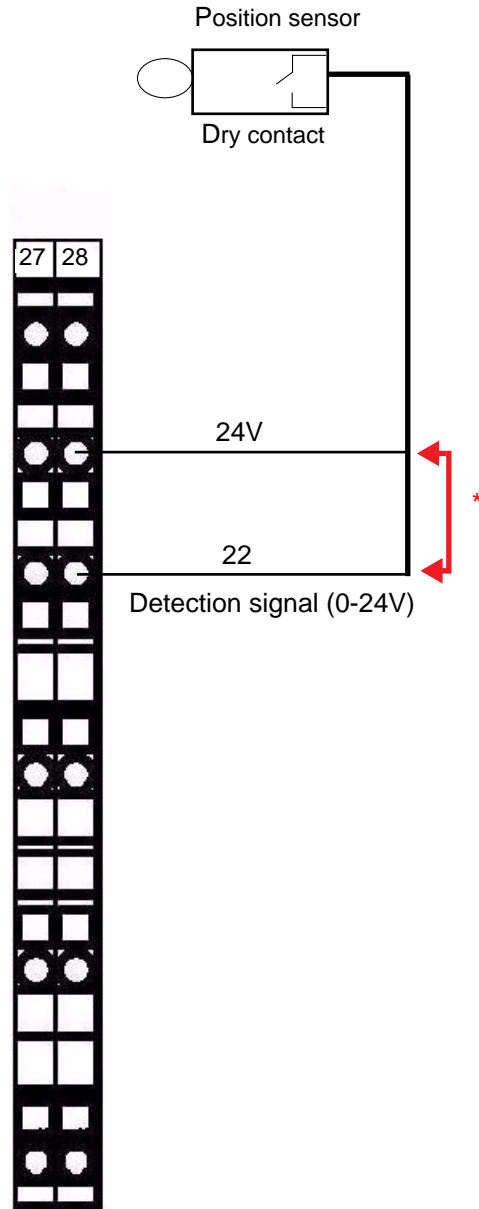

**\*: bridging to be installed if detection input is not used.  
Except if the TCR modules are installed in the cabinet.**



**WARNING:** Indeed, the uninterrupted spraying (forced detection) should not be only engaged when the turbines of the FCR modules are in established mode.  
The turbines of the TCR modules must be manually started on the module, then the spraying (uninterrupted detection or automatic) can be used.

### 7.9.2. Low powder level detection

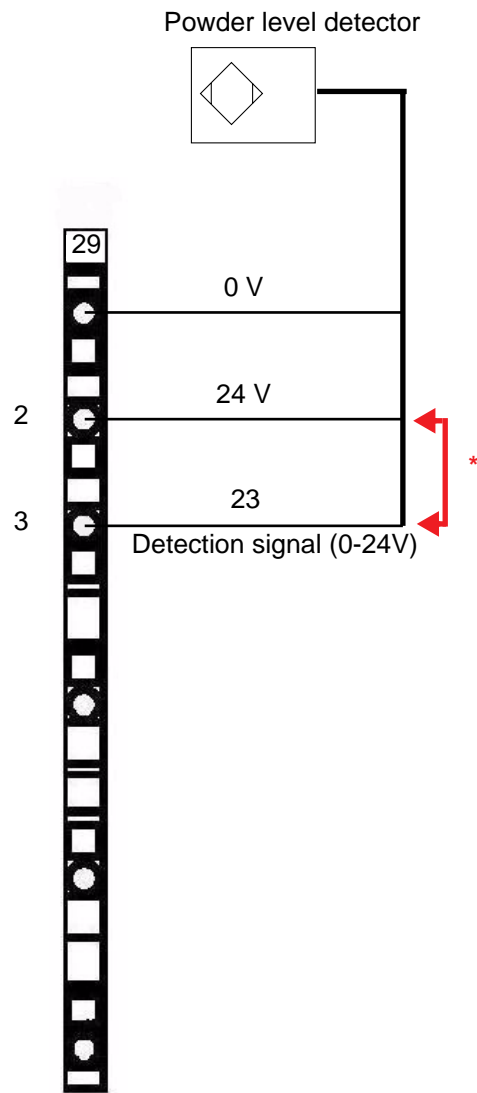

**\*: bridging to be installed if low powder level detection input is not used.**

The module is putting in fault if input (23-wire) is activated (24V or contact closed), the module manages only a three-wire detector.



### 7.9.3. External fault lamp

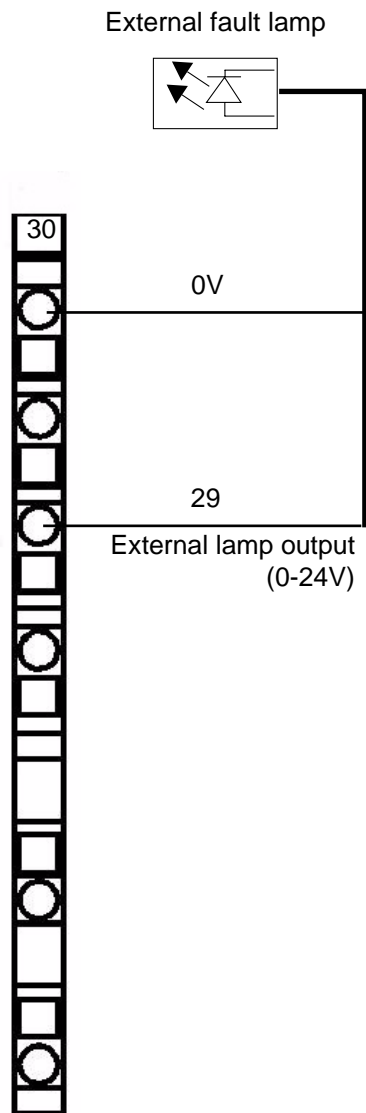

Information given by the external fault lamp (optional) is exactly the same as the information given by the red "Fault" indicator light located on the front face of the FCR cabinet.

7.9.4. External fault input / booth ventilation running / conveyor running

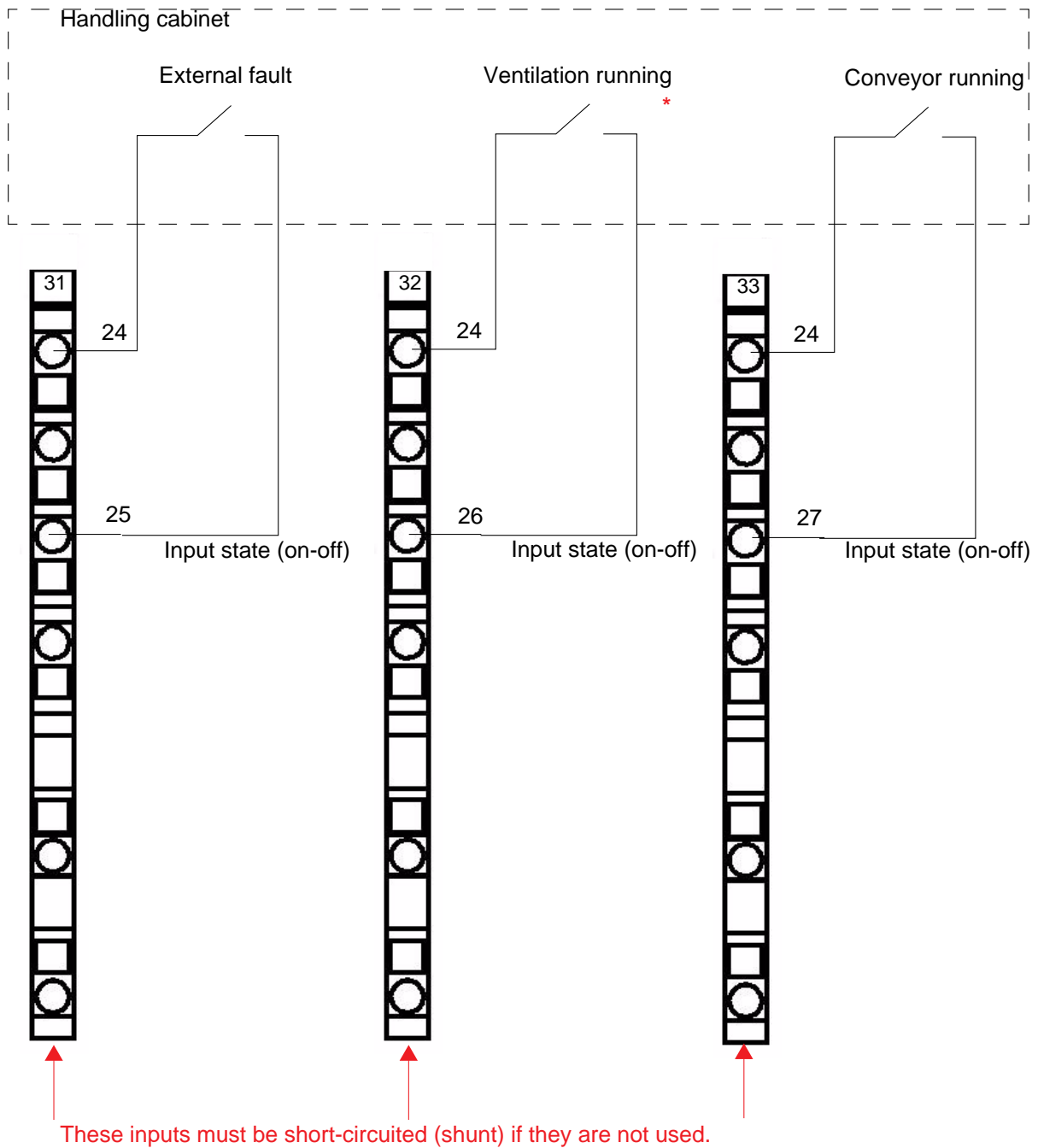

**WARNING:** Atomization (powder or liquid paints) must be imperatively interlocked with the operation of the booth ventilation in order to have a correct flammable or explosive limit (LEL), any other use is under the responsibility of the operator.

### 7.9.5. External emergency stop inputs

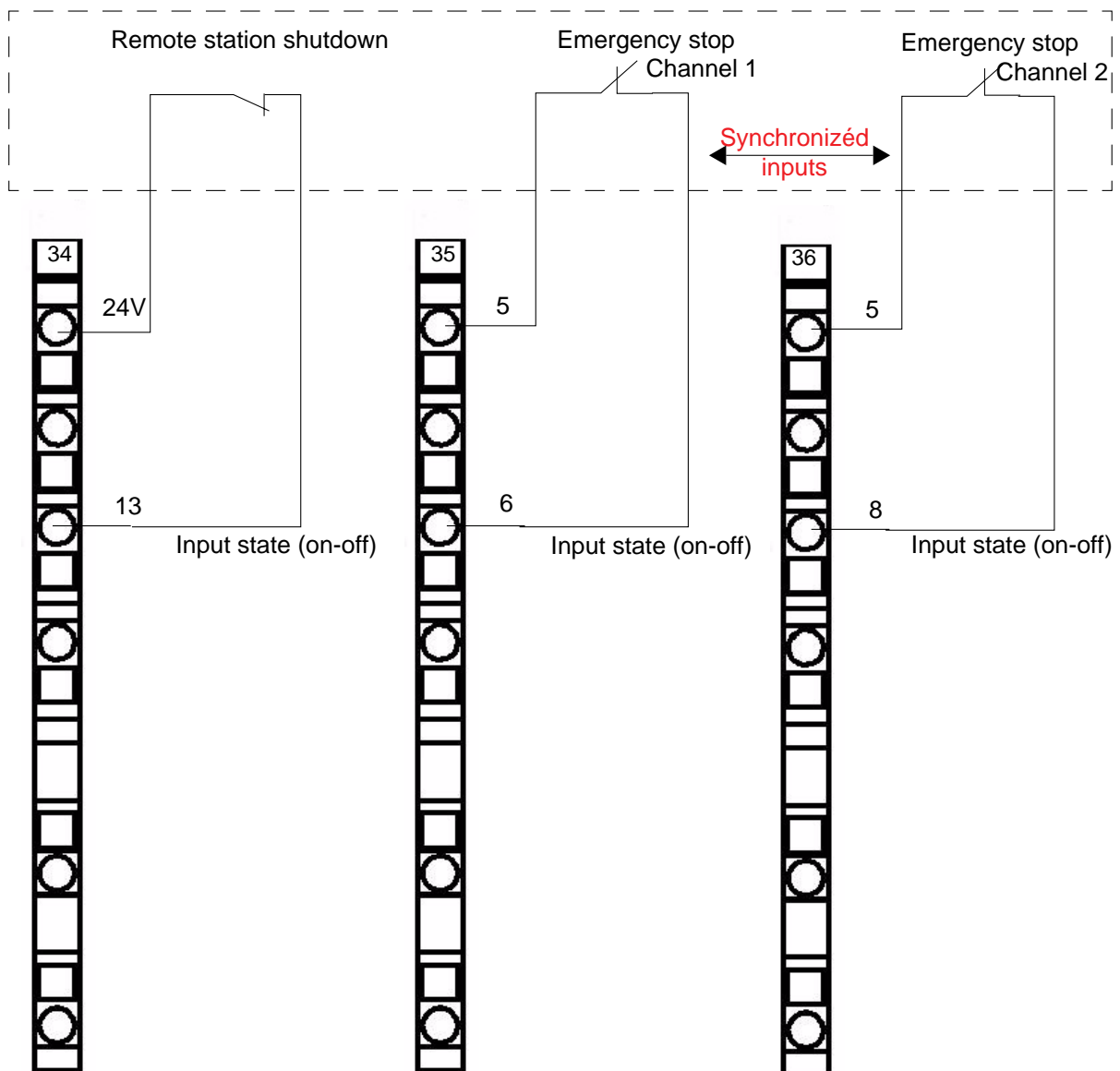

All these inputs must be short-circuited (shunt) if they are not used.

- The remote installation stop allows to switch off the contactor of starting of the module and thus to switch off the power on the installation if necessary (fire for example). It is necessary to open the contact to stop the installation.
- The outside emergency stop is connected in series with the emergency stop of the module. It is necessary to open both contacts to activate an emergency stop.
- The use of both synchronized inputs " emergency stop " allows to guarantee a level of electric safety category 3 defined by the analysis of risks.
- If only one contact " emergency stop " is available, it is possible to add a bridge between the wires 6 and 8 to insure the functioning.



**WARNING:** In the last case, the level of electric safety decreases and is not any more in accordance with the analysis of risks. This degraded functioning lives under the responsibility of the user.

### 7.9.6. Conveyor authorization / Emergency stop outputs

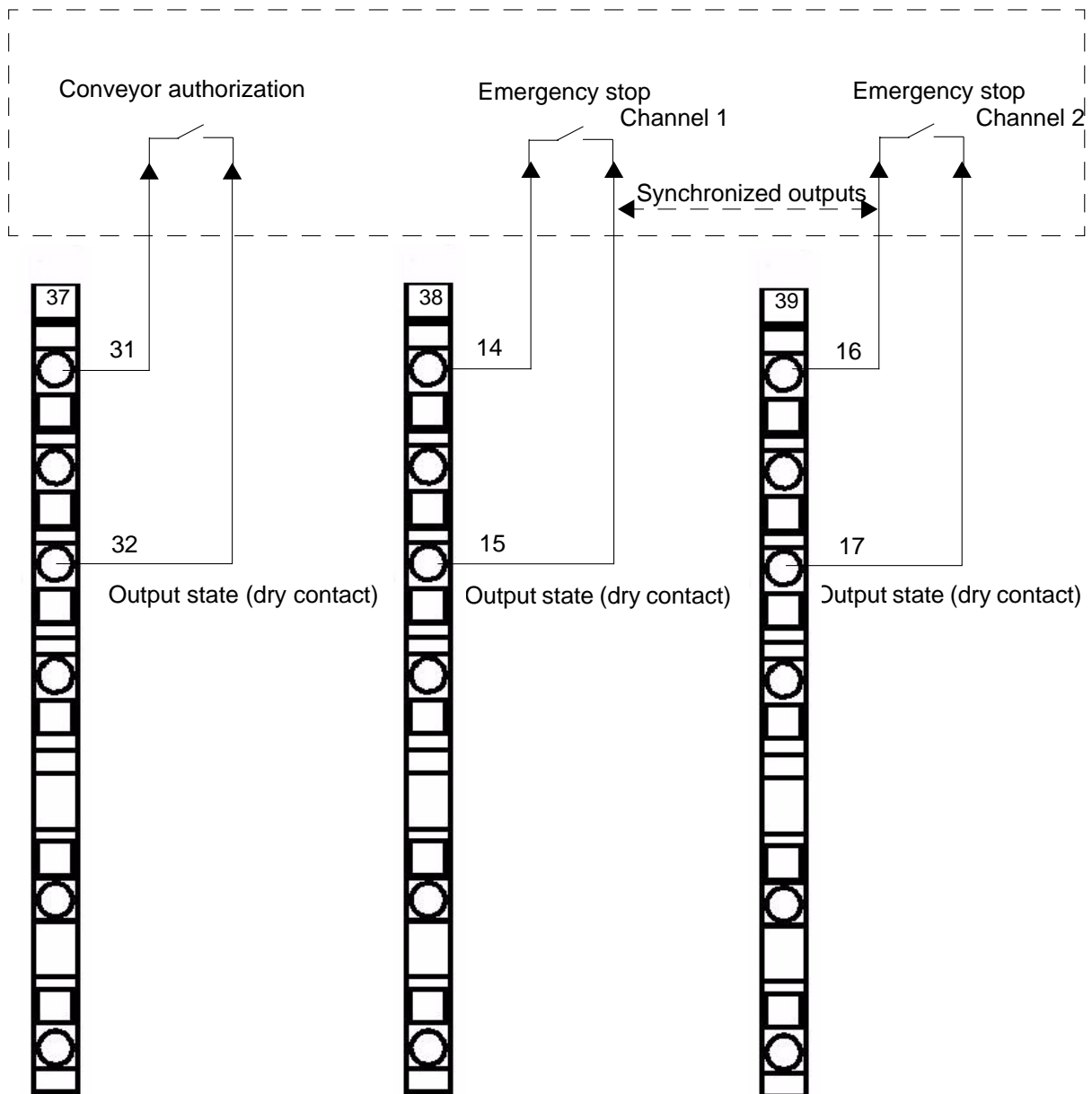

- When the module authorizes the advance of the conveyor, the contact is then closed.
- The module sends back 2 synchronized outputs " emergency stop " allowing to guarantee a level of electric safety category 3, when there is no emergency stop the contact is closed. Only one contact can be used, in that case the level of safety decreases. It belongs to the user to define the necessary minimum electric level of safety according to the analysis of risks relative to the module to be secured.



**WARNING:** The choice of the level of electric safety is under the responsibility of the user according to the analysis of risks of the various groups or the global assembly.

## 8. Spare parts

Item	P/N	Description	Qty	Unit of sale	First priority	Wear
-	910004346	Programmed mini-PLC	1	1	-	-
-	130000427	Air filter cartridge	1	1	-	-
-	E6FCKD420	Fuse cartridge for 16 A aM 10*38 power supply module	1	10	-	-
-	E6FCKC420	Fuse cartridge for 16 A gG 10*38 transformer kit	1	10	-	-