



DOCUMENTATION - DOKUMENTATION - DOCUMENTACIÓN

POMPE / PUMP / PUMPE / BOMBA

**THOR 34.106**

**AIRMIX<sup>®</sup>**

Notice / Manual / Betriebsanleitung / Libro : 582.082.110 - 1605

Date / Datum / Fecha : 27/05/16

Annule / Supersede / Ersetzt / Anula :

Modif. / Änderung :

**NOTICE ORIGINALE / TRANSLATION FROM THE ORIGINAL MANUAL**  
**/ ÜBERSETZUNG DER ORIGINAL BETRIEBSANLEITUNG**  
**/ TRADUCCIÓN DEL MANUAL ORIGINAL**

**IMPORTANT : Lire attentivement tous les documents avant le stockage, l'installation ou la mise en service du matériel concerné (à usage strictement professionnel).**

**Before assembly and start-up, please read and clearly understand all the documents relating to this equipment (professional use only).**

**WICHTIGER HINWEIS: Vor Lagerung, Installation oder Inbetriebnahme des Geräts bitte sämtliche Dokumente sorgfältig lesen (Einsatz nur von geschultem Personal).**

**IMPORTANTE : Lea con atención todos los documentos antes de almacenar, instalar o poner en marcha el equipo (uso exclusivamente profesional).**

PHOTOS ET ILLUSTRATIONS NON CONTRACTUELLES. MATÉRIELS SUJETS A MODIFICATION(S) SANS PREAVIS.

THE PICTURES AND DRAWINGS ARE NON CONTRACTUAL. WE RESERVE THE RIGHT TO MAKE CHANGES WITHOUT PRIOR NOTICE.

ALLE IN DIESEM DOKUMENT ENTHALTENEN SCHRIFTLICHEN ANGABEN UND ABBILDUNGEN STELLEN DIE NEUESTEN PRODUKTINFORMATIONEN DAR. WIR BEHALTEN UNS DAS RECHT VOR, JEDERZEIT OHNE VORANKÜNDIGUNG ÄNDERUNGEN VORZUNEHMEN.

LAS FOTOGRAFÍAS E ILUSTRACIONES NO SON VINCULANTES. LOS MATERIALES ESTÁN SUJETOS A CAMBIOS SIN PREVIO AVISO.

**KREMLIN - REXSON**

150, avenue de Stalingrad

93 245 - STAINS CEDEX - France

☎ : 33 (0)1 49 40 25 25      Fax : 33 (0)1 48 26 07 16

**www.kremlin-rexson.com**



<p align="center"><b>FR</b></p> <p><b>Pour une utilisation sûre, il est de votre responsabilité de :</b></p> <ul style="list-style-type: none"> <li>• Lire attentivement tous les documents contenus dans le CD joint avant la mise en service de l'équipement,</li> <li>• D'installer, d'utiliser, d'entretenir et de réparer l'équipement conformément aux préconisations de KREMLIN REXSON ainsi qu'aux réglementations nationales et/ou locales,</li> <li>• Vous assurez que les utilisateurs de cet équipement ont été formés, ont parfaitement compris les règles de sécurité et qu'ils les appliquent.</li> </ul>	<p align="center"><b>UK</b></p> <p><b>To ensure safe use of the machinery, it is your responsibility to:</b></p> <ul style="list-style-type: none"> <li>• Carefully read all documents contained on the enclosed CD before putting the machinery into service,</li> <li>• Install, use, maintain and repair the machinery in accordance with KREMLIN REXSON's recommendations and national and/or local regulations,</li> <li>• Make sure that the users of the machinery have received proper training and that they have perfectly understood the safety rules and apply them.</li> </ul>	<p align="center"><b>DE</b></p> <p><b>Eine sichere Nutzung setzt voraus, dass Sie: :</b></p> <ul style="list-style-type: none"> <li>• alle in der CD enthaltenen Dokumente vor der Inbetriebnahme der Anlage aufmerksam lesen,</li> <li>• die Anlage im Einklang mit den Empfehlungen von KREMLIN REXSON sowie mit den nationalen und/oder lokalen Bestimmungen installieren, verwenden, warten und reparieren,</li> <li>• sich vergewissern, dass die Nutzer dieser Anlage angemessen geschult wurden, die Sicherheitsbestimmungen verstanden haben und sie anwenden.</li> </ul>
<p align="center"><b>ES</b></p> <p><b>Para una utilización segura, será de su responsabilidad:</b></p> <ul style="list-style-type: none"> <li>• leer atentamente todos los documentos que se incluyen en el CD adjunto antes de la puesta en servicio del equipo,</li> <li>• instalar, utilizar, efectuar el mantenimiento y reparar el equipo con arreglo a las recomendaciones de KREMLIN REXSON y a la normativa nacional y/o local,</li> <li>• cerciorarse de que los usuarios de este equipo han recibido la formación necesaria, han entendido perfectamente las normas de seguridad y las aplican.</li> </ul>	<p align="center"><b>IT</b></p> <p><b>Per un uso sicuro, vi invitiamo a:</b></p> <ul style="list-style-type: none"> <li>• leggere attentamente tutta la documentazione contenuta nel CD allegato prima della messa in funzione dell'apparecchio,</li> <li>• installare, utilizzare, mantenere e riparare l'apparecchio rispettando le raccomandazioni di KREMLIN REXSON, nonché le normative nazionali e/o locali,</li> <li>• accertarvi che gli utilizzatori dell'apparecchio abbiano ricevuto adeguata formazione, abbiano perfettamente compreso le regole di sicurezza e le applichino.</li> </ul>	<p align="center"><b>PT</b></p> <p><b>Para uma utilização segura, é da sua responsabilidade:</b></p> <ul style="list-style-type: none"> <li>• Ler atentamente todos os documentos incluídos no CD em anexo antes de pôr o equipamento em funcionamento,</li> <li>• Proceder à instalação, utilização, manutenção e reparação do equipamento de acordo com as preconizações de KREMLIN REXSON, bem como com outros regulamentos nacionais e/ou locais aplicáveis,</li> <li>• Assegurar-se que os utilizadores do equipamento foram devidamente capacitados, compreenderam perfeitamente e aplicam as devidas regras de segurança.</li> </ul>
<p align="center"><b>NL</b></p> <p><b>Voor een veilig gebruik dient u:</b></p> <ul style="list-style-type: none"> <li>• alle document op de bijgevoegde cd aandachtig te lezen alvorens het apparaat in werking te stellen,</li> <li>• het apparaat te installeren, gebruiken, onderhouden en repareren volgens de door KREMLIN REXSON gegeven aanbevelingen en overeenkomstig de nationale en/of plaatselijke reglementeringen,</li> <li>• zeker te stellen dat de gebruikers van dit apparaat zijn opgeleid, de veiligheidsregels perfect hebben begrepen en dat zij die ook toepassen.</li> </ul>	<p align="center"><b>SE</b></p> <p><b>För en säker användning av utrustningen ansvarar ni för följande:</b></p> <ul style="list-style-type: none"> <li>• Läs noga samtliga dokument som finns på den medföljande cd-skivan innan utrustningen tas i drift.</li> <li>• Installera, använd, underhåll och reparera utrustningen enligt anvisningarna från KREMLIN REXSON och enligt nationella och/eller lokala bestämmelser.</li> <li>• Försäkra er om att användare av denna utrustning erhållit utbildning, till fullo förstått säkerhetsföreskrifterna och tillämpar dem.</li> </ul>	<p align="center"><b>FI</b></p> <p><b>Käytön turvallisuuden varmistamiseksi velvollisuutesi on:</b></p> <ul style="list-style-type: none"> <li>• Lukea huolella kaikki CD:llä olevat asiakirjat ennen laitteiston käyttöönottoa,</li> <li>• Noudattaa laitteiston asennuksessa, käytössä, kunnossapidossa ja huollossa KREMLIN REXSON in suosituksia sekä kansallisia ja/tai paikallisia määräyksiä,</li> <li>• Varmistaa, että laitteiston käyttäjät ovat koulutettuja ja ymmärtävät täysin turvallisuusmääräykset ja miten niitä sovelletaan.</li> </ul>
<p align="center"><b>PL</b></p> <p><b>Dla zapewnienia bezpiecznego użytkowania na użytkownika spoczywa obowiązek:</b></p> <ul style="list-style-type: none"> <li>• Uważnego zapoznania się ze wszystkimi dokumentami znajdującymi się na załączonej płycie CD przed pierwszym uruchomieniem urządzenia,</li> <li>• Instalowania, użytkowania, konserwacji i naprawy urządzenia zgodnie z zaleceniami firmy KREMLIN REXSON oraz z przepisami miejscowymi,</li> <li>• Upewnienia, że wszyscy przeszkoleni użytkownicy urządzenia zrozumieli zasady bezpieczeństwa i stosują się do nich.</li> </ul>	<p align="center"><b>CS</b></p> <p><b>Pro bezpečné používání jste povinni:</b></p> <ul style="list-style-type: none"> <li>• Před uvedením zařízení do provozu si pozorně přečíst veškeré dokumenty obsažené na příloženém CD,</li> <li>• Nainstalovat, používat, udržovat a opravovat zařízení v souladu s pokyny firmy KREMLIN REXSON a s národními a/nebo místními legislativními předpisy,</li> <li>• Ujistit se, že uživatelé tohoto zařízení byli vyškoleni, že dokonale pochopili bezpečnostní pravidla a že je dodržují.</li> </ul>	<p align="center"><b>RU</b></p> <p><b>Для целей безопасного использования необходимо:</b></p> <ul style="list-style-type: none"> <li>• Ознакомиться со всеми документами, содержащимися в прилагаемом компакт-диске до ввода оборудования в эксплуатацию;</li> <li>• Устанавливать, использовать, производить техническое обслуживание и ремонт оборудования в соответствии с рекомендациями KREMLIN REXSON и национальным и/или местным законодательством;</li> <li>• Убедиться, что пользователи настоящего оборудования прошли подготовку, надлежащим образом усвоили правила безопасности и обеспечивают их соблюдение.</li> </ul>

Déclaration(s) de conformité au verso de ce document / Declaration(s) of conformity at the back of this document / Konformitätserklärung(en) auf der Rückseite dieser Unterlage / Declaración (es) de conformidad en el reverso de este documento / Dichiarazione/i di conformità sul retro del presente documento / Declaração(ões) de conformidade no verso do documento / Conformiteitsverklaring(en) op de keerzijde van dit document / Försäkran om överensstämmelse på omstående sida av detta dokument / Vaatimustenmukaisuusvakuutukset tämän asiakirjan kääntöpuolella / Deklaracja(e) zgodności na odwrocie dokumentu / Prohlášení o shodě se nachází/nacházejí na zadní straně tohoto dokumentu / Сертификат(ы) соответствия расположены на оборотной стороне настоящего документа

**VALABLE JUSQU'AU 19 AVRIL 2016**  
**VALID UNTIL 19 APRIL 2016**  
**GÜLTIG BIS ZUM 19. APRIL 2016**  
**VALIDEZ HASTA EL 19 DE ABRIL DE 2016**  
**VALIDO FINO AL 19 APRILE 2016**  
**APLICÁVEL ATÉ 19 DE ABRIL DE 2016**  
**GELDIG TOT 19 APRIL 2016**  
**GÄLLER TILL OCH MED DEN 19 APRIL 2016**  
**VOIMASSA 19.4.2016 SAAKKA**  
**WAŻNOŚĆ DO 19 KWIETNIA 2016 R.**  
**PLATÍ DO 19. DUBNA 2016**  
**ДЕЙСТВИТЕЛЬНО ДО 19 АПРЕЛЯ 2016 ГОДА**



**DECLARATION CE DE CONFORMITE**  
**EC DECLARATION OF CONFORMITY**  
**EG KONFORMITÄTSEKTLÄRUNG**  
**DECLARACIÓN CE DE CONFORMIDAD**  
**DICHIARAZIONE CE DI CONFORMITÀ**  
**DECLARAÇÃO CE DE CONFORMIDADE**  
**EG-VERKLARING VAN OVEREENSTEMMING**  
**EG-FÖRSÄKRAN OM ÖVERENSSTÄMMELSE**  
**EY-VAATIMUKSEN MUKAISUUSVAKUUTUS**  
**DEKLARACJA ZGODNOŚCI CE**  
**CE PROHLÁŠENÍ O SHODĚ**  
**ДЕКЛАРАЦИЯ СООТВЕТСТВИЯ CE**

Le fabricant / The manufacturer / Der Hersteller / El fabricante / Il produttore / O fabricante / De fabrikant / Tillverkare / Valmistaja / Producent / Výrobce / Изготовитель:	<b>KREMLIN REXSON</b> 150, avenue de Stalingrad 93 240 - STAINS - FRANCE Tél. 33 (0)1 49 40 25 25 - Fax : 33 (0)1 48 26 07 16
------------------------------------------------------------------------------------------------------------------------------------------------------------------------------------------	----------------------------------------------------------------------------------------------------------------------------------------

Déclare que le matériel désigné ci-après / Herewith declares that the equipment / erklårt hiermit, dass die / Declara que el material designado a continuación / Dichiaro che il materiale sottoindicato / Declara que o material a seguir designado / verklaart dat de hieronder aangeduide apparatuur / Kungör att den utrustning som anges här nedan / ilmoittaa, että alla mainitut laitteistot / Oświadczka, że wymienione poniżej urządzenia / Prohlašuje, že níže uvedené vybavení / Декларирует, что ниженазванное оборудование:

**POMPES / PUMPS / PUMPEN / BOMBAS / POMPE / POMPEN / PUMPAR / PUMPUT / POMPY / НАСОСЫ**

THOR 60.60
THOR 34.106
THOR 63.106
THOR 32.207
THOR 53.216
THOR 82.216

Est conforme à la législation d'harmonisation de l'Union applicable suivante / Is in conformity with the relevant Union harmonisation legislation / Erfüllt die einschlägigen Harmonisierungsrechtsvorschriften der Union / es conforme con la legislación de armonización pertinente de la Unión / è conforme alla pertinente normativa di armonizzazione dell'Unione / in overeenstemming met de desbetteffende harmonisatiewetgeving van de Unie / med den relevanta harmoniserade unionslagstiftningen / on asiaa koskevan unionin yhdenmukaistamislainsäädännön vaatimusten mukainen / jest zgodny z odpowiednimi wymaganiami unijnego prawodawstwa harmonizacyjnego / Shoduje se s následující příslušnou evropskou harmonizační legislativou / Соответствует следующим стандартизированным нормам Союза

Directive ATEX / ATEX Directive / ATEX Richtlinie / Directiva ATEX / Direttiva ATEX / Diretiva ATEX / ATEX-Richtlijn / ATEX-direktivet / ATEX-direktivi / Dyrektywa ATEX / Směrnice ATEX / Директива ATEX  II 2G IIA T3	<b>94/9/CE</b>
---------------------------------------------------------------------------------------------------------------------------------------------------------------------------------------------------------------------------------------------------------------------------------------------------------------	----------------

Dominique LAGOUGE

Directeur Général / Chief Executive Officer / Generaldirektor  
 / Director General / Direttore Generale / Director Geral / Algemeen  
 Directeur / Generaldirektör / Pääjohtaja / Dyrektor Naczelny  
 / Dyrektor Generalny / Generální ředitel / Генеральный директор

Fait à Stains, le / Established in Stains, on / Geschehen zu Stains, am / En Stains, a / Redatto a Stains, / Vastgesteld te Stains, / Utformat i Stains, den / Stains, Ranska, / Sporządzono w Stains, dnia / Stains, dnia / Издано в г. Стен (Stains) 07/05/2015 - 05/07/2015

**VALABLE A PARTIR DU 20 AVRIL 2016**  
**VALID FROM 20 APRIL 2016**  
**GÜLTIG AB DEM 20. APRIL 2016**  
**VALIDEZ A PARTIR DEL 20 DE ABRIL DE 2016**  
**VALIDO A PARTIRE DAL 20 APRILE 2016**  
**APLICÁVEL A PARTIR DE 20 DE ABRIL DE 2016**  
**GELDIG VANAF 20 APRIL 2016.**  
**GÄLLER FRÅN OCH MED DEN 20 APRIL 2016**  
**VOIMASSA 20.4.2016 ALKAEN**  
**WAŻNOŚĆ OD 20 KWIETNIA 2016 R.**  
**PLATÍ OD 20. DUBNA 2016**  
**ДЕЙСТВИТЕЛЬНО С 20 АПРЕЛЯ 2016 ГОДА**



**DECLARATION UE DE CONFORMITE**  
**UE DECLARATION OF CONFORMITY**  
**EU-KONFORMITÄTSEKTLÄRUNG**  
**DECLARACIÓN UE DE CONFORMIDAD**  
**DICHIAZIONE DI CONFORMITÀ UE**  
**DECLARAÇÃO UE DE CONFORMIDADE**  
**EU-CONFORMITEITSVERKLARING**  
**EU-FÖRSÄKRAN OM ÖVERENSSTÄMMESE**  
**EU-VAATIMUKSEN MUKAISUUSVAKUUTUS**  
**DEKLARACJA ZGODNOŚCI UE**  
**EU PROHLÁŠENÍ O SHODĚ**  
**ДЕКЛАРАЦИЯ О СООТВЕТСТВИИ НОРМАМ ЕС**

Le fabricant / The manufacturer / Der Hersteller / El fabricante / Il produttore / O fabricante / De fabrikant / Tillverkare / Valmistaja / Producent / Výrobce / Изготовитель:	<b>KREMLIN REXSON</b> 150, avenue de Stalingrad 93 240 - STAINS - FRANCE Tél. 33 (0)1 49 40 25 25 - Fax : 33 (0)1 48 26 07 16
------------------------------------------------------------------------------------------------------------------------------------------------------------------------------------------	----------------------------------------------------------------------------------------------------------------------------------------

Déclare que le matériel désigné ci-après / Herewith declares that the equipment / erklårt hiermit, dass die / Declara que el material designado a continuación / Dichiaro che il materiale sottoindicato / Declara que o material a seguir designado / verklaart dat de hieronder aangeduide apparatuur / Kungör att den utrustning som anges här nedan / ilmoittaa, että alla mainitut laitteistot / Oświadcz, że wymienione poniżej urządzenia / Prohlašuje, že níže uvedené vybavení / Декларирует, что нижеуказанное оборудование:

**POMPES / PUMPS / PUMPEN / BOMBAS / POMPE / POMPEN / PUMPAR / PUMPUT / POMPY / НАСОСЫ**

THOR 60.60
THOR 34.106
THOR 63.106
THOR 32.207
THOR 53.216
THOR 82.216

Est conforme à la législation d'harmonisation de l'Union applicable suivante / Is in conformity with the relevant Union harmonisation legislation / Erfüllt die einschlägigen Harmonisierungsrechtsvorschriften der Union / es conforme con la legislación de armonización pertinente de la Unión / è conforme alla pertinente normativa di armonizzazione dell'Unione / in overeenstemming met de desbetreffende harmonisatiewetgeving van de Unie / med den relevanta harmoniserade unionslagstiftningen / on asiaa koskevan unionin yhdenmukaistamislainsäädännön vaatimusten mukainen / jest zgodny z odpowiednimi wymaganiami unijnego prawodawstwa harmonizacyjnego / Shoduje se s následující příslušnou evropskou harmonizační legislativou / Соответствует следующим стандартизированным нормам Союза

Directive ATEX / ATEX Directive / ATEX Richtlinie / Directiva ATEX / Direttiva ATEX / Diretiva ATEX / ATEX-Richtlijn / ATEX-direktivet / ATEX-direktivi / Dyrektywa ATEX / Směrnice ATEX / Директива ATEX  II 2G IIA T3	<b>2014/34/UE</b>
Procédure d'évaluation de la conformité : Module A Documentation technique (Annexe VIII) archivée par : / Conformity assessment procedure: Module A Technical documentation (ANNEX VIII) recorded by: / Verfahren zur Konformitätsbewertung: Modul A Technische Unterlagen (ANLAGE VIII) archiviert durch: / Procedimiento de evaluación de la conformidad: Módulo A Documentación técnica (ANEXO VIII) archivada por: / Procedura di valutazione della conformità: Modulo A Documentazione tecnica (ALLEGATO VIII) archiviata a cura di: / Procedimento de avaliação da conformidade: Módulo A Documentação técnica (ANEXO VIII) arquivada por: / Conformiteitsbeoordelingsprocedure: Module A Technische documentatie (BIJLAGE VIII) gearhiveerd door: / Förfarande för bedömning av överensstämmelse: Modul A Teknisk dokumentation (BILAGA VIII) arkiverad av: / Vaatimustenmukaisuusarviointimenetelmä: moduuli A Tekninen dokumentaatio (LIITE VIII) arkistoitu: / Procedura oceny zgodności: Modul A Dokumentacja techniczna (ZAŁĄCZNIK VIII) zarchiwizowane przez: / Postup posuzování shody: Modul A Technická dokumentace (PŘÍLOHA VIII) archivována: / Процедура оценки соответствия: Модуль A Техническая документация (ПРИЛОЖЕНИЕ VIII), архивированная: ISSeP Zoning A. Schweitzer Rue de la Platinerie B - 7340 COLFONTAINE BELGIQUE	

Dominique LAGOUGE

Directeur Général / Chief Executive Officer / Generaldirektor  
 / Director General / Direttore Generale / Director Geral / Algemeen  
 Directeur / Generaldirektör / Pääjohtaja / Dyrektor Naczelny  
 / Dyrektor Generalny / Generální ředitel / Генеральный директор

Fait à Stains, le / Established in Stains, on / Geschehen zu Stains, am / En Stains, a / Redatto a Stains, / Vastgesteld te Stains, / Utformat i Stains, den / Stains, Ranska, / Sporządzono w Stains, dnia / Stains, dnia / Издано в г. Стен (Stains) 04/04/2016 - 04/04/2016



# INSTALLATION AND SAFETY INSTRUCTIONS

## TRANSLATION OF THE ORIGINAL MANUAL

**IMPORTANT** : Before assembly and start-up, please read and clearly understand all the documents relating to this equipment (professional use only).

*THE PICTURES AND DRAWINGS ARE NON CONTRACTUAL. WE RESERVE THE RIGHT TO MAKE CHANGES WITHOUT PRIOR NOTICE.*

### **KREMLIN - REXSON**

150, avenue de Stalingrad

93 245 - STAINS CEDEX – France

**☎** : 33 (0)1 49 40 25 25      *Fax* : 33 (0)1 48 26 07 16

**[www.kremlin-rexson.com](http://www.kremlin-rexson.com)**

# 1. SAFETY INSTRUCTIONS

## GENERAL SAFETY INSTRUCTIONS



**CAUTION** : The equipment can be dangerous if you do not follow our instructions concerning installation and servicing described in this manual and in accordance with applicable European standards and local national safety regulations.

Please carefully read all the instruction literature before operating your equipment.

**Only trained operators can use the equipment** (To acquire an essential training, please contact the "KREMLIN REXSON University" training center - Stains).

The foreman must ensure that the operator has understood the safety instructions for this equipment as well as the instructions in the manuals for the different parts and accessories.

Read carefully all instruction manuals, label markings before operating the equipment.



















Incorrect use may result in injury. This equipment is for professional use only. It must be used only for what it has been designed for. Never modify the equipment. The parts and accessories supplied must be regularly inspected. Defective or worn parts must be replaced.

**Guards (motor cover, coupling shields, connectors,...) have been designed for a safe use of the equipment.**  
**The manufacturer will not be held responsible for bodily injury or failure and / or property damage due to destruction, the overshadowing or the partial or total removal of the guards.**

**Never exceed the equipment components' maximum working pressure.**

Comply with regulations concerning safety, fire risks, electrical regulations in force in the country of final destination of the material. Use only products or solvent compatible with the parts in contact with the material (refer to data sheet of the material manufacturer).

## PICTOGRAMS

					
NIP HAZARD	WARNING MOVING ELEVATOR	WARNING MOVING PARTS	WARNING MOVING SHOVEL	DO NOT EXCEED THIS PRESSURE	HIGH PRESSURE HAZARD
					
RELIEF OR DRAIN VALVE	WARNING HOSE UNDER PRESSURE	WEAR GLASSES OBLIGATORY	WEAR OF GLOVES IS OBLIGATORY	PRODUCT VAPOR HAZARDS	WARNING HOT PARTS OR AREAS
					
ELECTRICAL HAZARD	WARNING FIRE HAZARDS	EXPLOSION HAZARDS	GROUNDING	WARNING (USER)	WARNING SERIOUS INJURIES

## FIRE - EXPLOSION - SPARKS - STATIC ELECTRICITY HAZARDS

A poor earth connection, inadequate ventilation, sparks or static electricity can cause an explosion or fire. to avoid these risks when using or servicing KREMLIN REXSON equipment, the following safety procedures must be followed :



- ensure a good earth connection and ground the parts to be handled i.e. solvents, materials, components and equipment,
- ensure adequate ventilation,
- keep working area clean and free from waste solvents, chemicals, or solid waste i.e. rags, paper and empty chemicals drums,
- never use electrical switches / power if in an atmosphere of volatile solvent vapour,
- stop working immediately in case of electrical arcs,
- never store chemicals and solvents in the working area.
- use paint whose flash point is the highest possible to prevent from any formation of gas and inflammable vapours (refer to materials' safety instructions),
- install a cover on the drums to reduce the diffusion of gas and vapours in the spraybooth.

## TOXIC PRODUCT HAZARDS

Toxic products or vapours can cause severe injury not only through contact with the body, but also if the products are ingested or inhaled. It is imperative :



- to know the material products and their risks,
- notified or hazardous materials must be stored in accordance with the regulations,
- the material must be stored in an appropriate container, never place materials in a container where there is a risk of spillage or leakage,
- a procedure must be applied for the safe disposal of waste material. It must comply with all prevailing regulations and legislations of the country where the equipment is to be used,
- protective clothing should always be worn in compliance with the material manufacturers' recommendations,
- depending on the application and chemical safety instructions, safety glasses, hearing protective earplug, gloves, foot wear, protective masks and possible breathing equipment should be worn to comply with the regulations (Refer to chapter "Safety equipment of KREMLIN selection guide).



### **CAUTION!**



It is forbidden to use material containing high concentrations of halogenated hydrocarbon solvents with **aluminium or zinc fillers** .Non-compliance with the instructions may cause explosion risk causing serious or fatal injury.

## **EQUIPMENT REQUIREMENTS**

**Guards (motor cover, coupling shields, connectors,...) have been designed for a safe use of the equipment.**

**The manufacturer will not be held responsible for bodily injury or failure and / or property damage due to destruction, the overshadowing or the partial or total removal of the guards.**

### **PUMP**



Before carrying out any work, it is imperative to read and clearly understand the disassembly and reassembly instructions before servicing. The operator must understand the equipment and the safety instructions. These instructions are available in the equipment manuals.



The air motor is designed to be mounted with a pump. Never modify any components or couplings. When operating, please keep hands away from moving parts. Before starting up the equipment, please read the PRESSURE RELIEF instructions. Please ensure that any relief or drain valves fitted are in good working order.

### **HOSES**

- Keep hoses out of circulation areas, moving parts or hot surfaces,
- Never expose product hoses to temperature higher than + 60°C / 140° F or lower than 0°C / 32° F,
- Never pull or use the hoses to move the equipment,
- Tighten all fittings as well as the hoses before operating the equipment,
- Check the hoses regularly; change them if they are damaged,
- Never exceed the working pressure (WP) indicated on the hose.

## **USED PRODUCTS**

Considering the wide variety of products that are available and can be used in our equipment it is impossible to check and make recommendations for all chemical data, regarding the risks of possible chemical attack and their long term chemical reaction

KREMLIN REXSON can not be held liable for :

- Compatibility of wetted parts,
- Risks to staff and the surroundings,
- for worn or defective parts, for faulty equipment or units, or the quality of final product.

It is the responsibility of the user to know and prevent any possible risks such as toxic vapours, fires or explosions. He shall determine the risks of immediate reactions or pursuant to repeated exposures of the staff,

KREMLIN REXSON shall not be liable for physical injuries, direct or indirect material damages caused by the use of chemicals.



## 2. HANDLING



### **Check the weight and the dimensions of the equipment**

**(☞ refer to 'Technical features' section of the instruction manual**

If weight and dimensions are too important, the unloading must be carried out by means of a forklift or any other appropriate means with a qualified personnel and in a clear horizontal area to prevent from risks of damage injury or an accident.

The centre of gravity is not in the centre of the machine : carry out by hand a stability-test after having lifted the whole at 10 cm / 3.937" maximum.

After the unloading, the handling of the whole (eg: elevator pump) is carried out by means of a pallet truck taking the bottom part of the frame.

**Remark : Each pump motor is fitted with a ring. The ring is designed for the hoisting of one pump and can not be used for the handling of the complete machine.**

## 3. STORING

Storing before installation :

- Storing ambient temperature : 0 / +50 °C / 0 / +122°F
- Protect the whole against dust, water trickling, dampness and shocks.

Storing after installation :

- Operating temperature : +15 / +35 °C / +59 / +138.2° F
- Protect the whole against dust, water trickling, dampness and shocks.

## 4. INSTALLATION OF THE EQUIPMENT

The machine is installed on a stable horizontal floor (for eg a concrete flag).



**To avoid risks caused by static electricity, the equipment as well as its components must be grounded.**

- **For the pumping equipments** (pumps, pneumatic rams, frame...), a section wire of 2.5 mm<sup>2</sup> is fixed on the material. Use this wire to connect the material to "the general ground". In case of severe environments (mechanical protection of the wire of earthing insufficient, vibrations, mobile material...) where function damages at the ground are probable, the user have to replace the provided wire of 2.5 mm<sup>2</sup> by a device more adapted to its environment (wire with a more important section, bonding strip, fixing by thimble with eyelet...),

The continuity of the ground must be controlled by a qualified electrician. If the continuity of the ground is not ensured, check the terminal, the wire and the earthing point. **Never** use the material without have solved this problem.

- In the severe cases of environments (mechanical protection of the wire of earthing insufficient, vibrations, mobile material...) where damages of the function put at the ground are probable, the user will have to replace the wire of 2.5 mm<sup>2</sup> provided, by a device more adapted to its environment (wire of more important section, bonding strip, fixing by thimble with eyelet...),
- **The gun** must be 'grounded' via a material hose or an air hose. In case of spraying by means of a gun with cup, the air hose must be conductive,
- **The materials to be painted** must also be grounded.

**All the materials situated in the working area shall be grounded.**



- **Never store** more than necessary inflammable materials inside the working area,
- The materials must be stored into **approved drums** and grounded,
- Use only grounded **metals containers** for the use of cleaning solvents,
- **Cardboard and paper are prohibited.**

## 5. MARKING OF THE EQUIPMENT

Each equipment has a marking plate.

The plate consists of the name of the manufacturer, the equipment part number and important information for correct use of the equipment (air pressure, electric power,...).



**DEMONTAGE / REMONTAGE  
DISASSEMBLY / REASSEMBLY  
DEMONTAGE / MONTAGE  
DESMONTAJE / MONTAJE**

**MOTEUR  
/ MOTOR  
THOR 3000**

**NOTICE ORIGINALE  
/ TRANSLATION FROM THE ORIGINAL MANUAL  
/ ÜBERSETZUNG DER ORIGINAL BEDIENUNGSANLEITUNG  
/ TRADUCCIÓN DEL LIBRO ORIGINAL**

**La pompe est soumise à la directive ATEX et ne doit en aucun cas être modifiée.  
Le non-respect de cette préconisation ne saurait engager notre responsabilité.  
/ The pump is manufactured under the ATEX agreement and can not be modified.  
KREMLIN REXSON will not be held responsible for any failure to comply with that instruction.**

**/ Diese Pumpe hat die ATEX Zulassung, deswegen darf sie nie verändert werden.  
Die Nichtbeachtung dieser Anordnung, können wir keine Verantwortung für eine einwandfreie, regelkonforme Funktion der Pumpe übernehmen.**

**/ La bomba es de conformidad a la directiva ATEX y no debe ser modificada, en ningún caso. KREMLIN REXSON no se hace responsable de que esta preconización no sea respetada.**

**Des protecteurs (capot moteur, protecteur d'accouplement, carters,...) sont mis en place pour une utilisation sûre du matériel.**

**Le fabricant ne peut être tenu pour responsable en cas de dommages corporels ainsi que des pannes et / ou endommagement du matériel résultant de la destruction, de l'occultation ou du retrait total ou partiel des protecteurs.**

**/ Guards (air motor cover, coupling shields, housings ...) have been designed for safe use of the equipment. The manufacturer will not be held responsible for bodily injury or failure and / or damage to property due to removal or partial removal of the guards.**

**/ Schutzvorrichtungen an diesem Gerät, wie Motorhaube, Kupplungsschutz, Gehäuse, ggf. Erdungskabel, sowie weitere Vorrichtungen, wurden für eine sichere Benutzung dieses Gerätes entwickelt und angebracht. Der Hersteller lehnt jede Verantwortung für Körperschäden, Fehlfunktionen, Beschädigung der Geräte und jegliche andere Fehler ab, die durch die ganze oder teilweise Entfernung Modifikation oder unsachgemäße Handhabung der Schutzvorrichtungen oder anderen Geräteteile entstehen.**

**/ Protectores (capó motor, protector de acoplamiento, cárteres,...) se colocan para una utilización segura del material. El fabricante no se hace responsable, en caso de daños personales, así como de las averías y / o daños del material, resultantes de la destrucción, la ocultación o la retirada total o parcial de los protectores.**

***Vous aurez besoin de / you need / Werkzeugaufstellung / Vd necesita***



***Graisses et colles / Greases and adhesives  
/ Fette und Kleber / Grasas y colas***

Repère / Index / Pos. / Índice	Instructions / Montage-Hinweis / Instrucciones	Désignation / Description / Bezeichnung / Descripción	Référence / Part number / Artikel-Nr. / Referencia
<b>A 1</b>	Graisse PTFE	Tube de graisse "TECHNILUB" (10 ml)	560.440.101
	PTFE grease	PTFE grease (10 ml / 0.0026 US gal)	
	PTFE-Fett	PTFE Fett (10 ml)	
	Grasa PTFE	Tubo de grasa "TECHNILUB" (10 ml)	
<b>C 2</b>	Colle Anaérobie frein filet faible	Loctite 222 (50 ml)	554.180.010
	Low strength - Anaerobic Adhesive	Loctite 222 (50 ml / 0.013 US gal)	
	Niedrigfester anaerober Kleber	Loctite 222 (50 ml)	
	Cola freno suave	Loctite 222 (50 ml)	

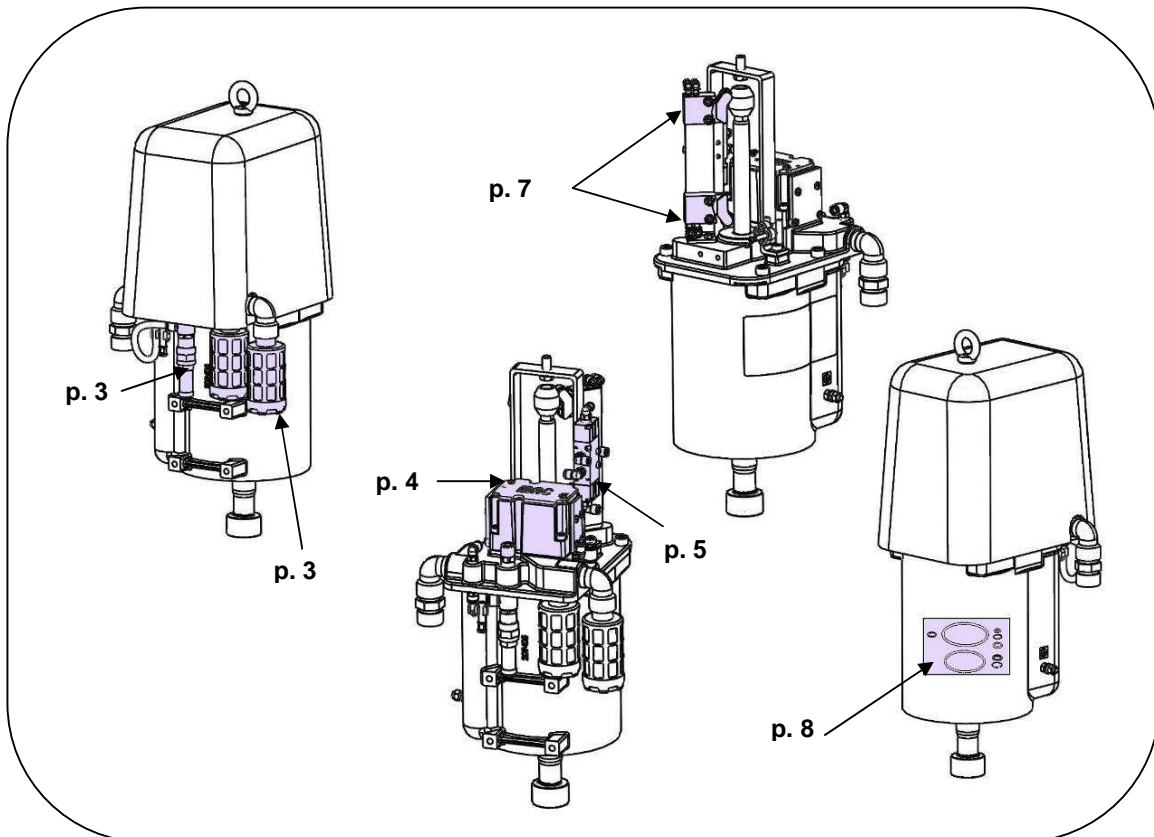

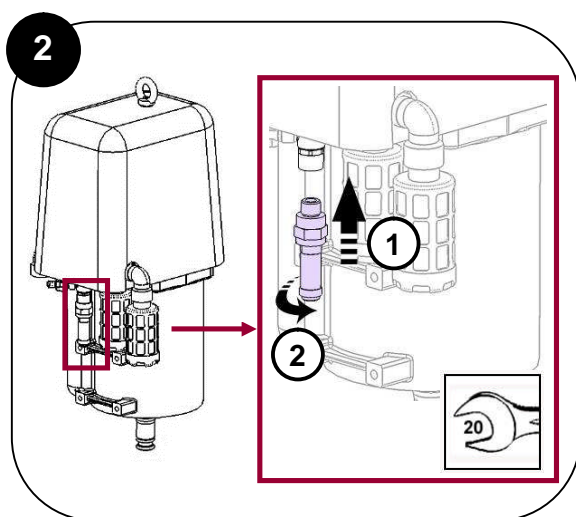
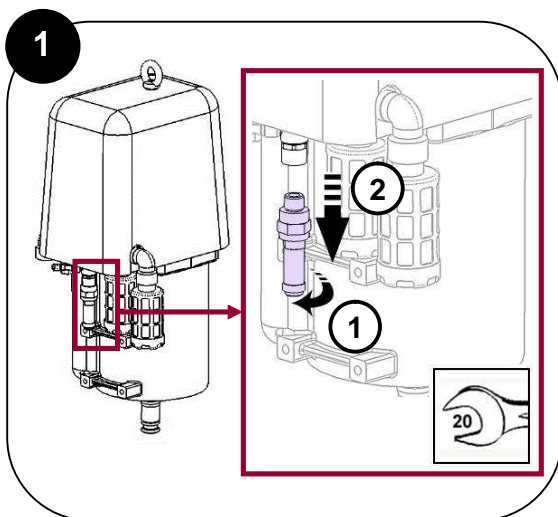
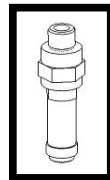
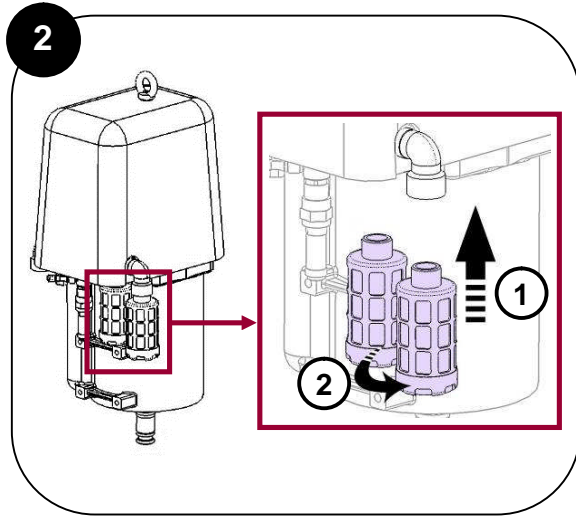
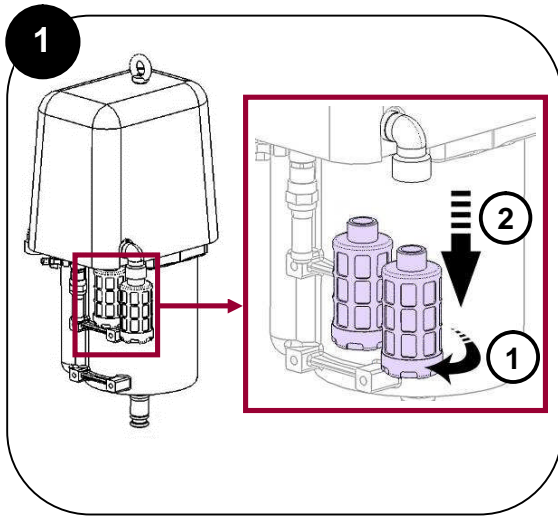
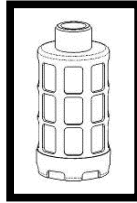

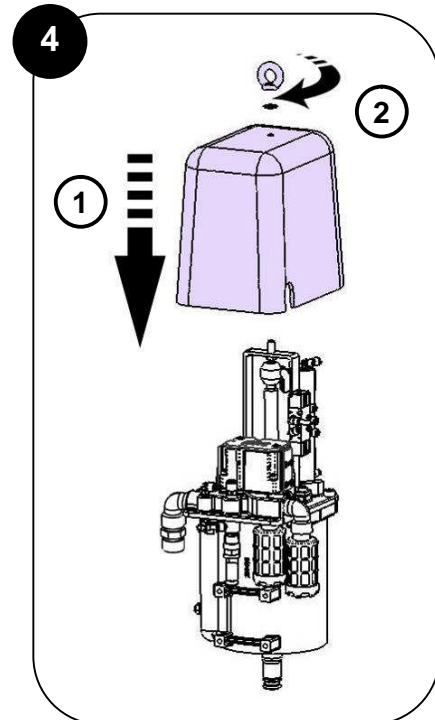
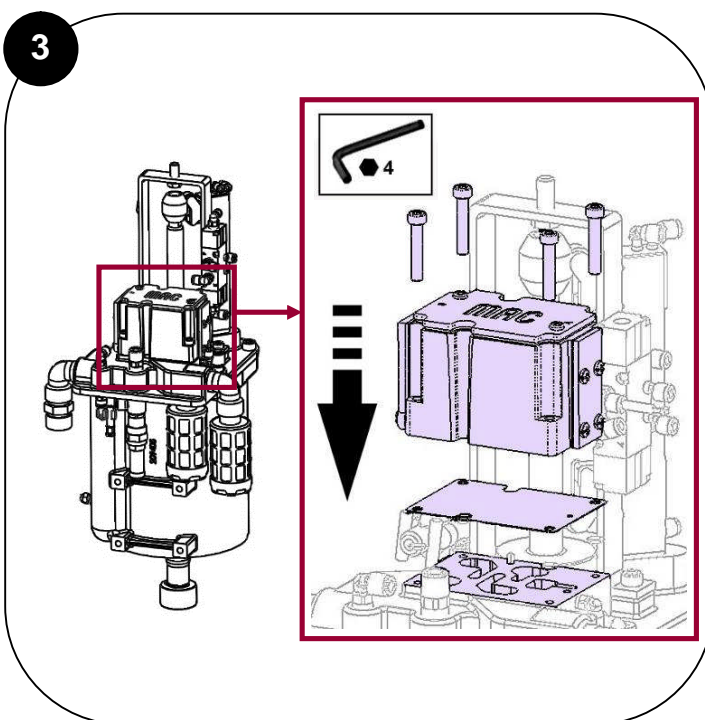
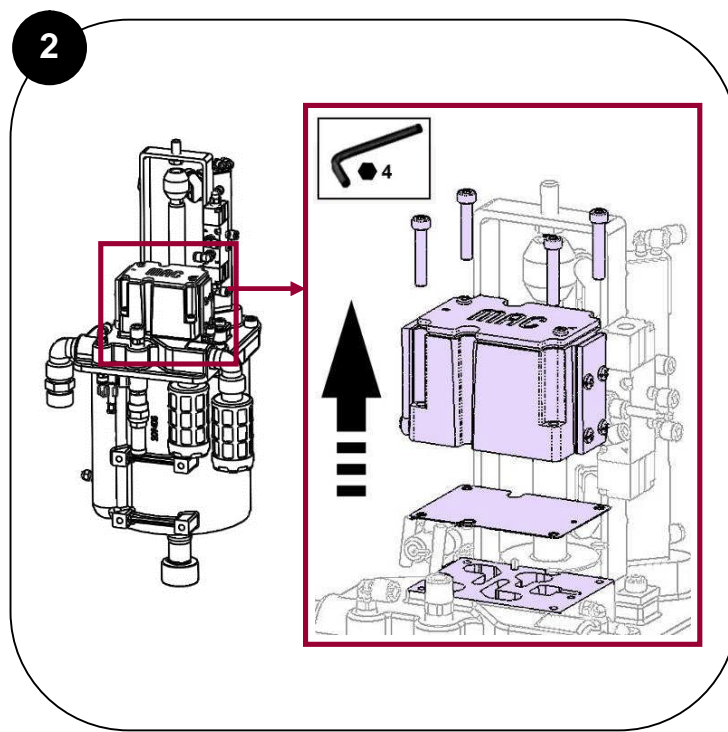
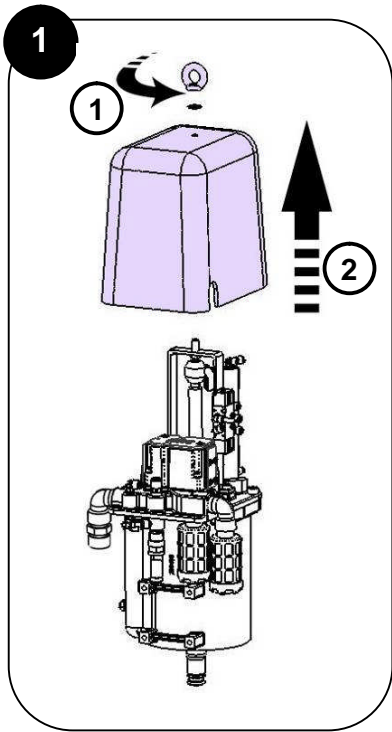
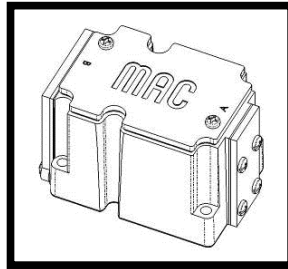

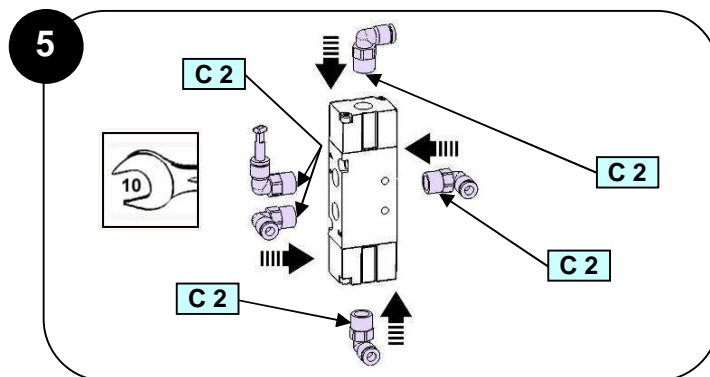
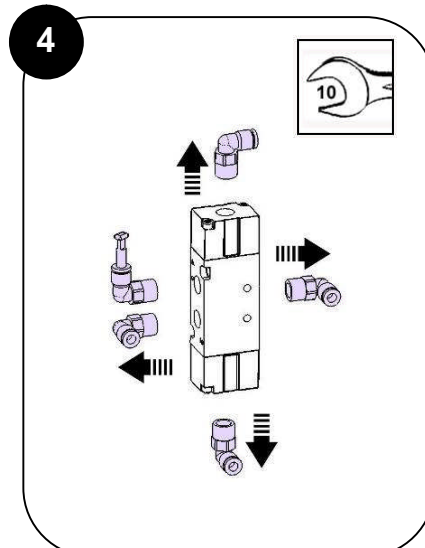
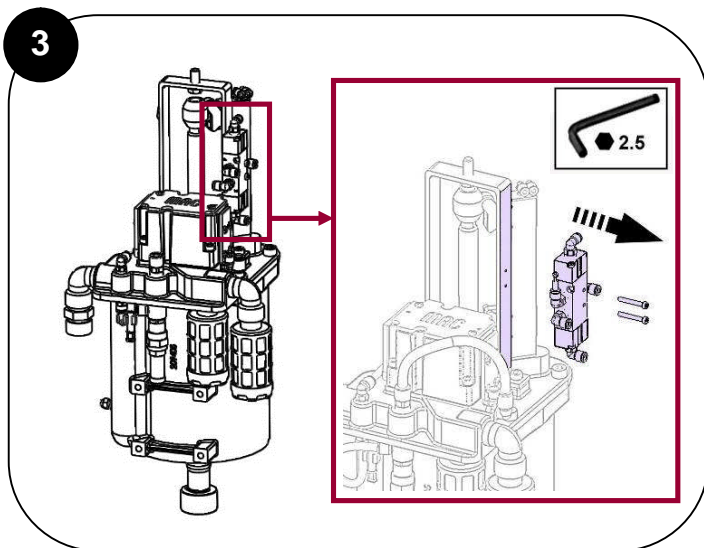
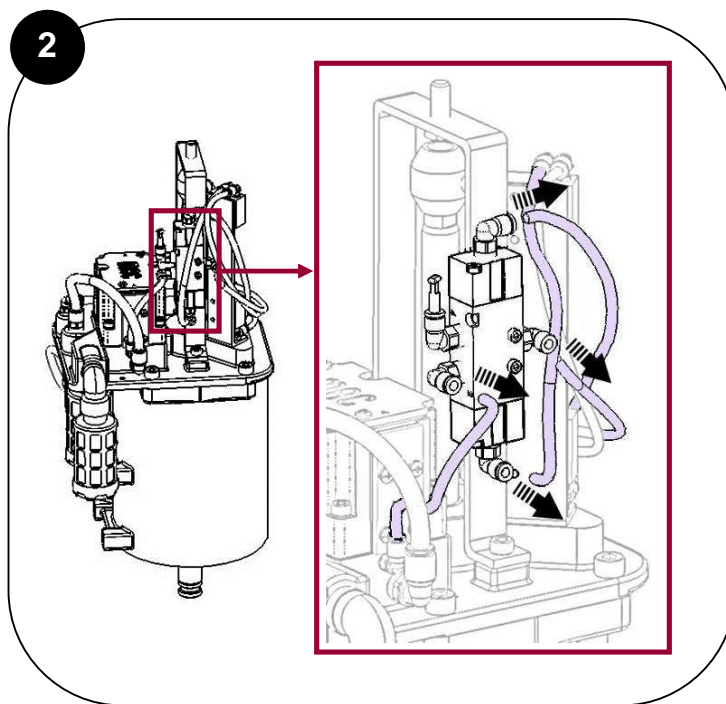
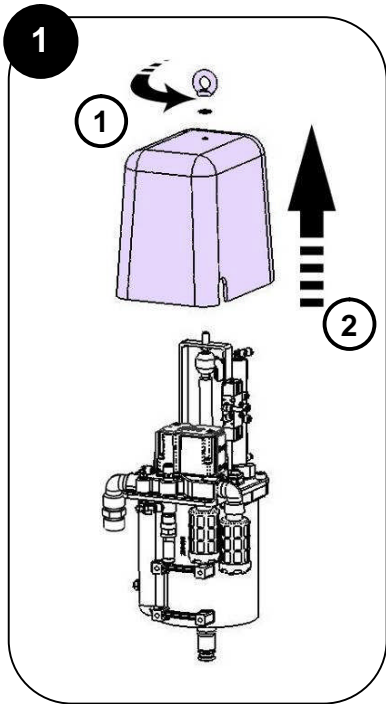
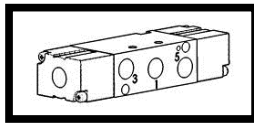

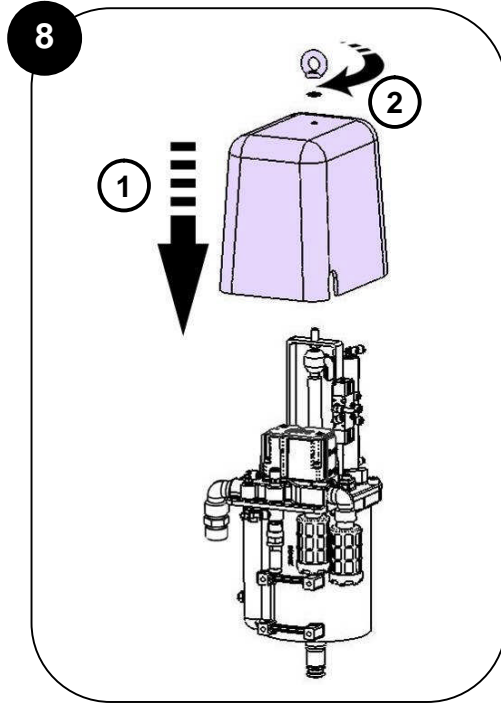
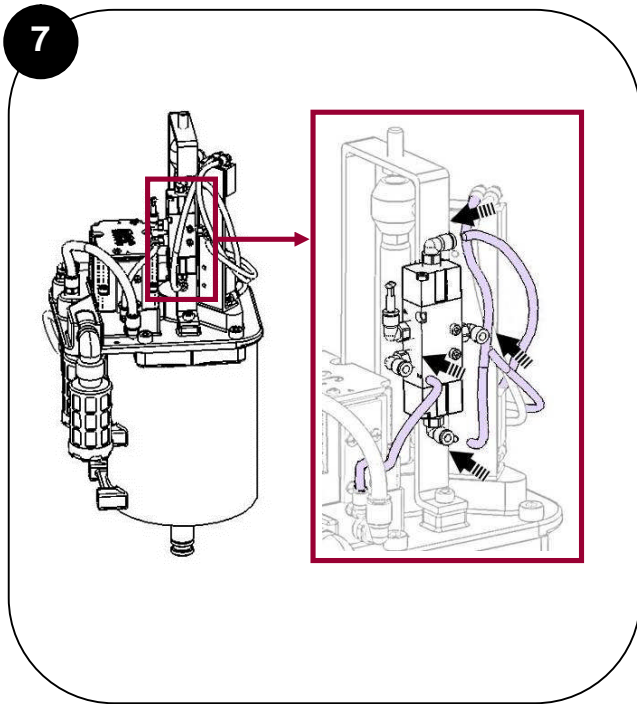
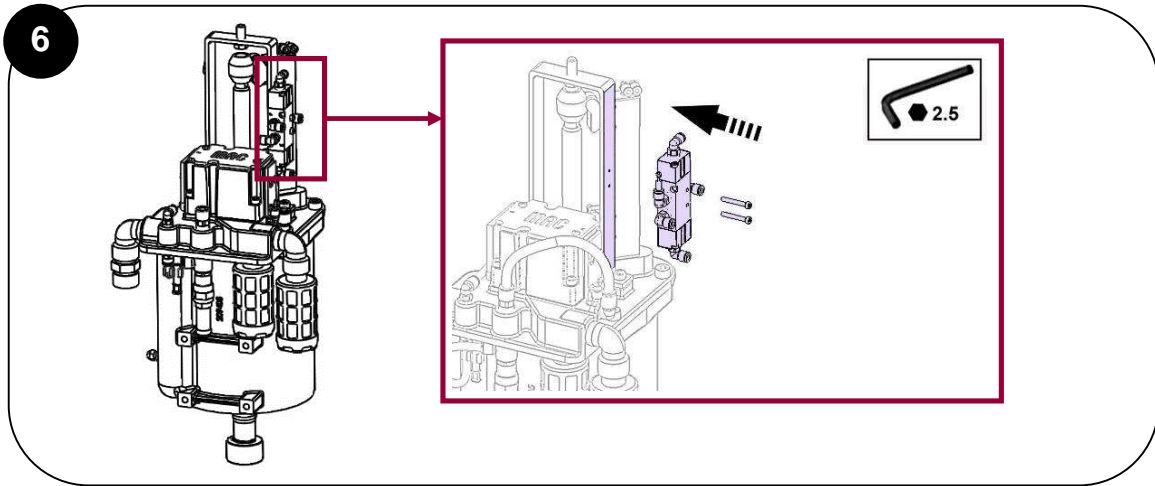



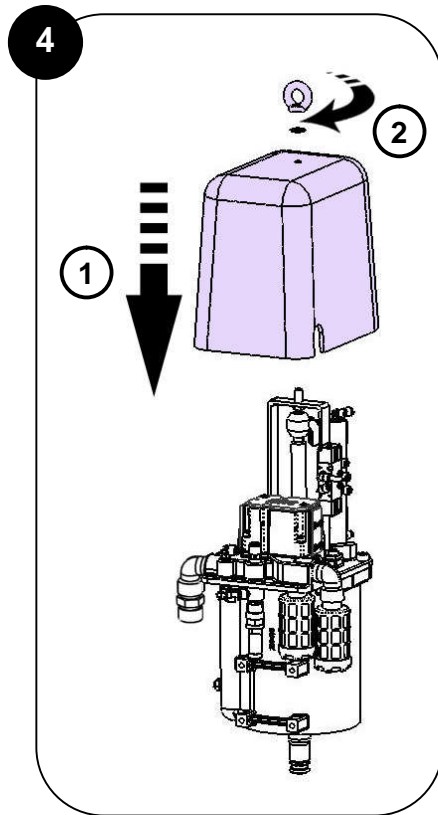
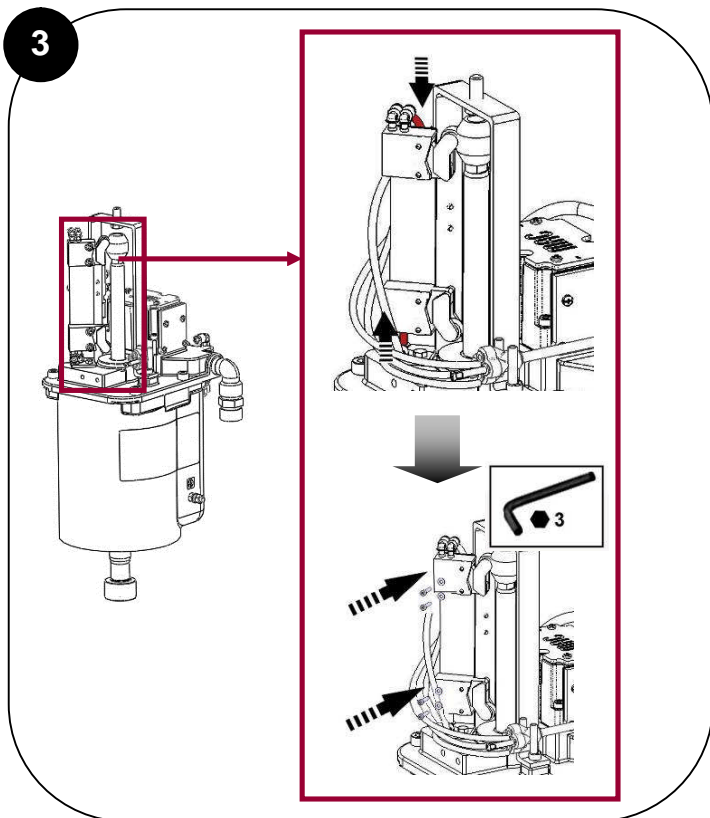
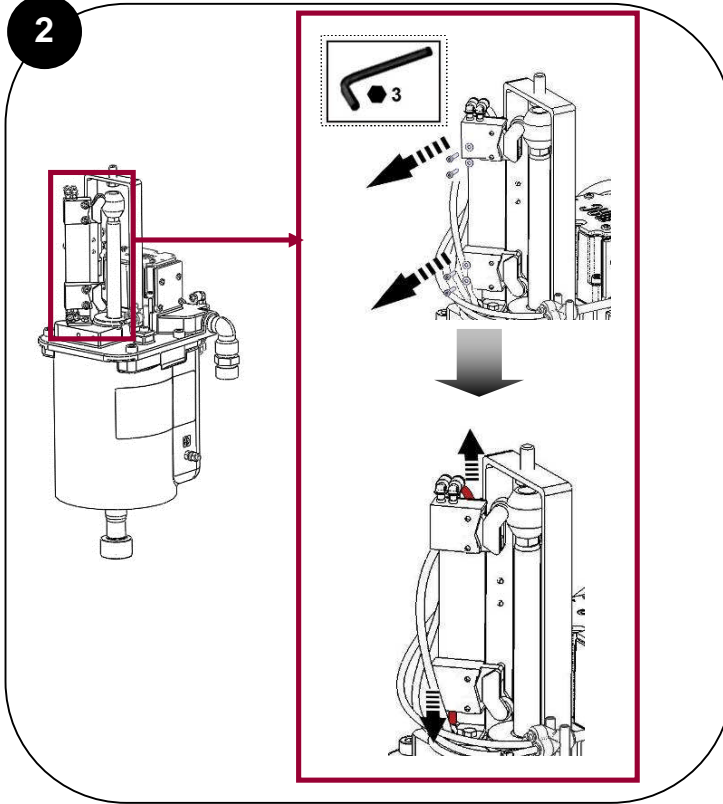
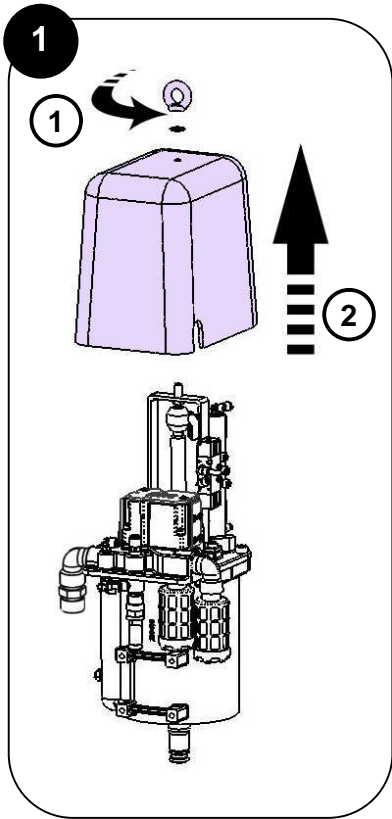
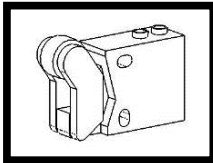

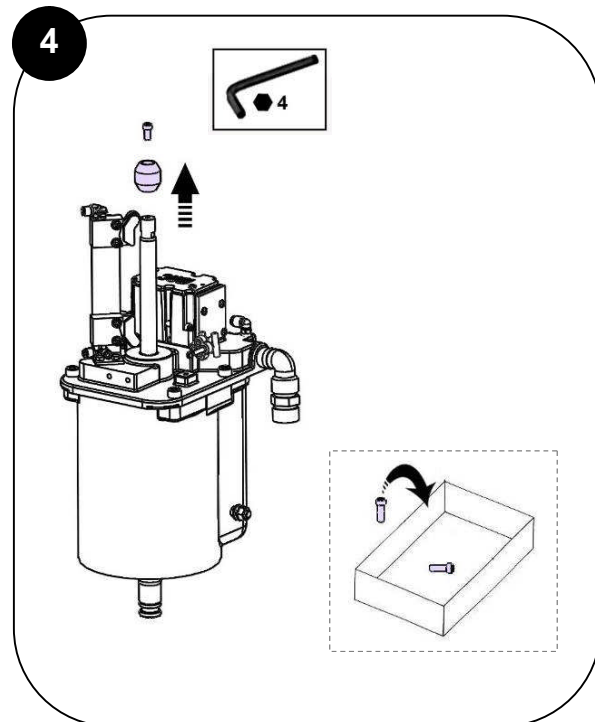
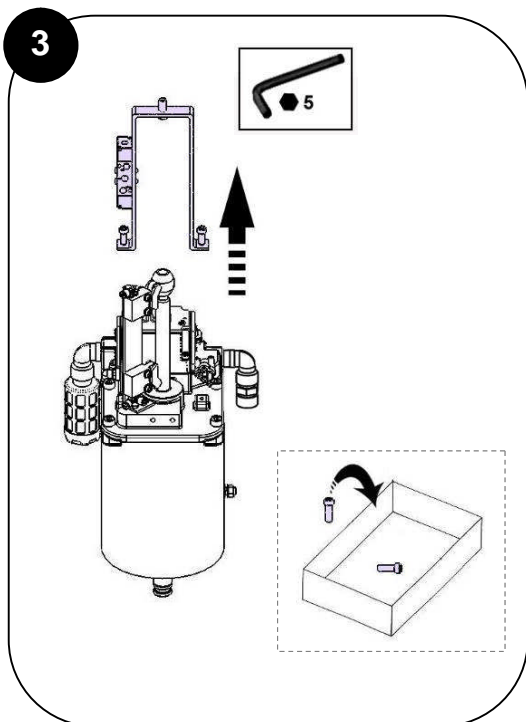
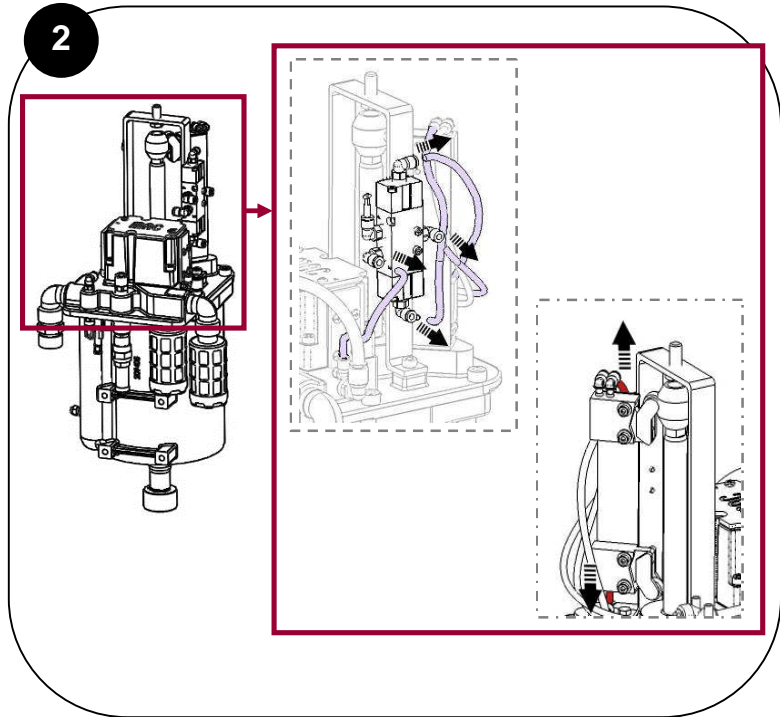
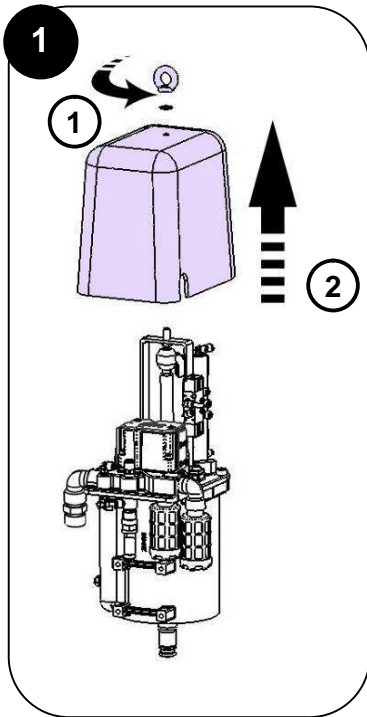
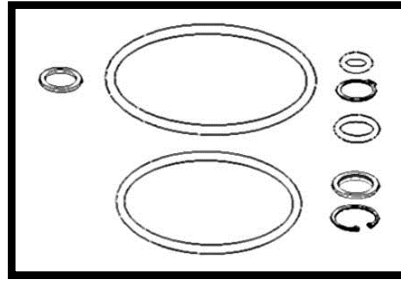

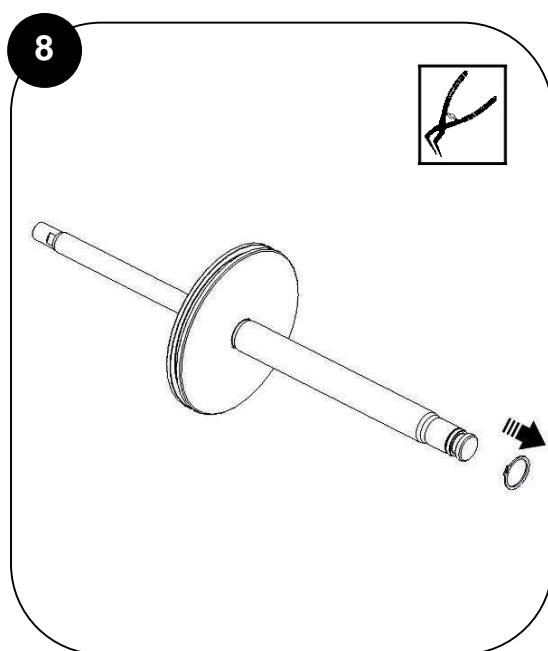
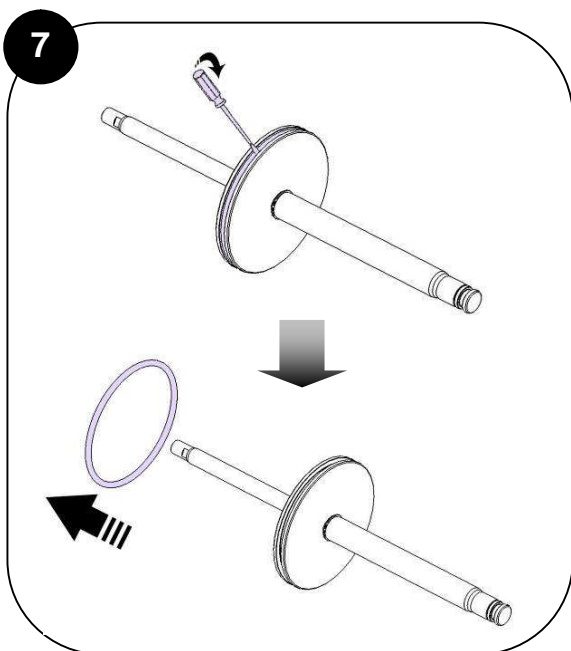
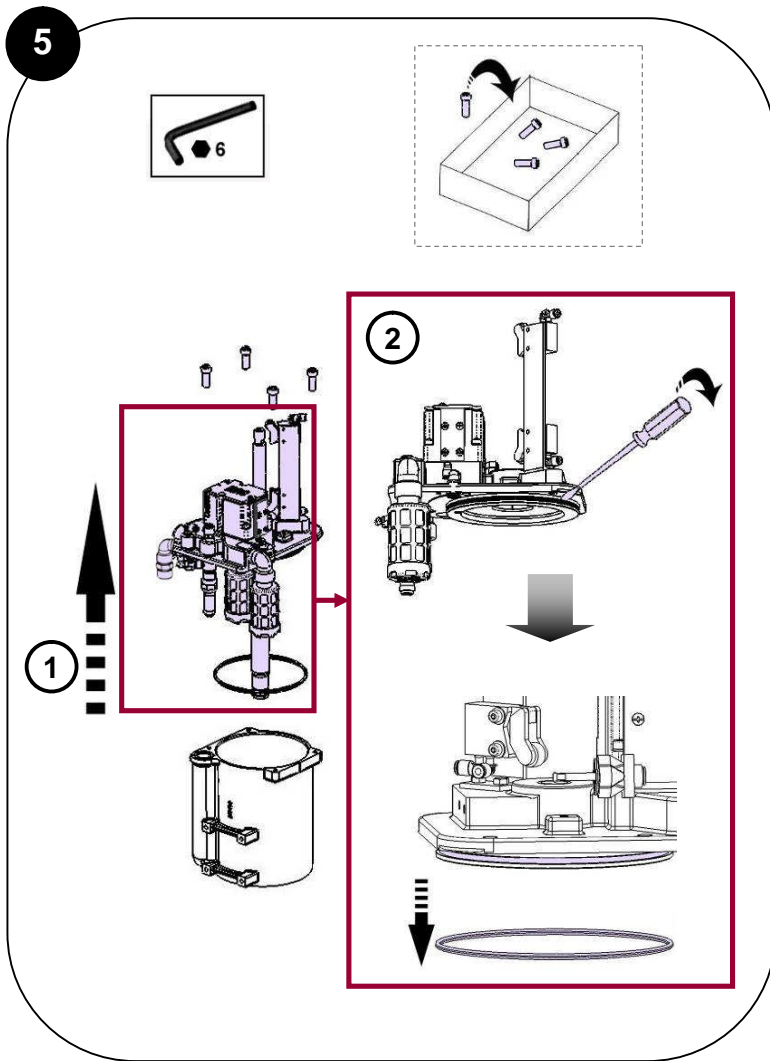

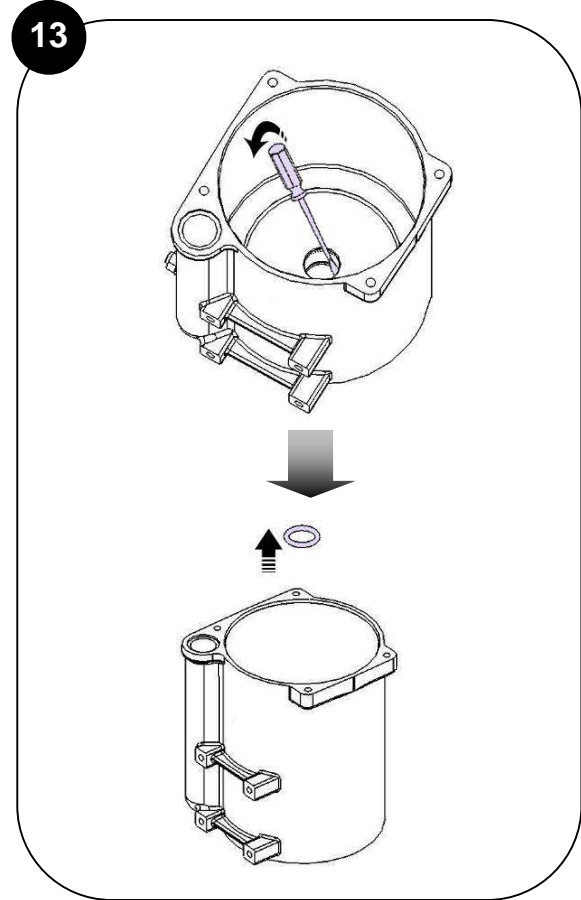
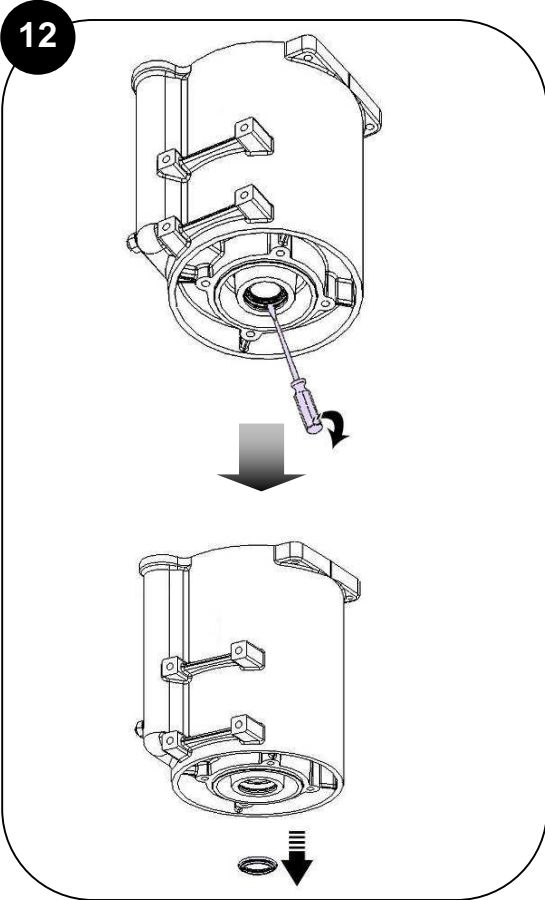
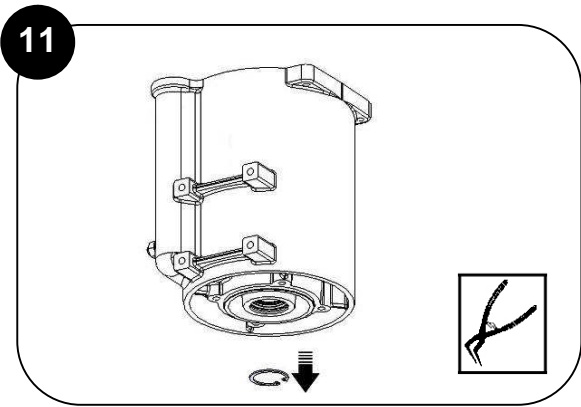
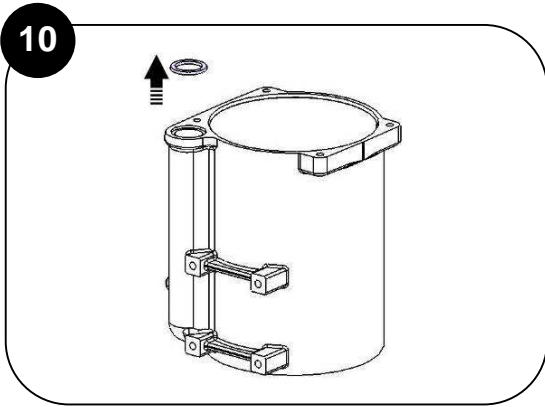
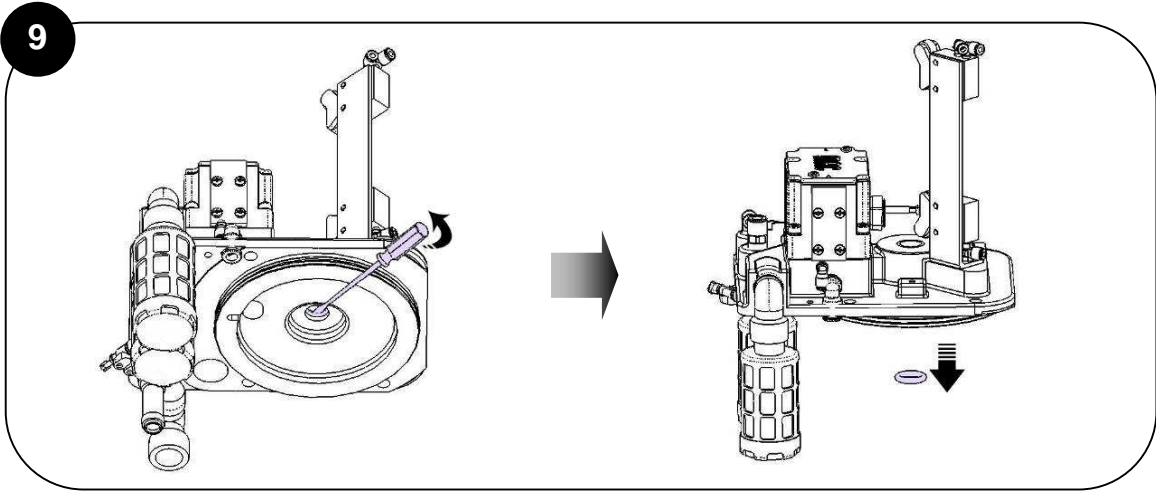

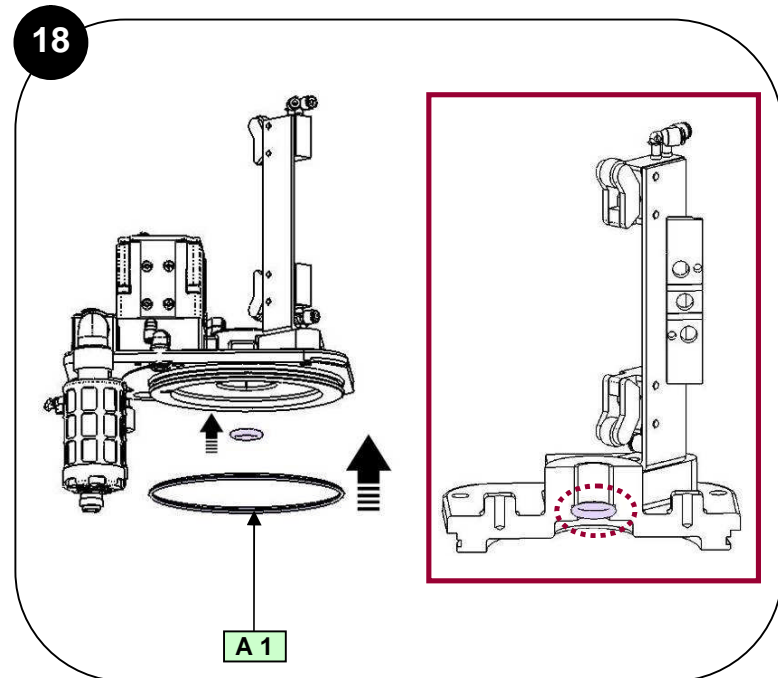
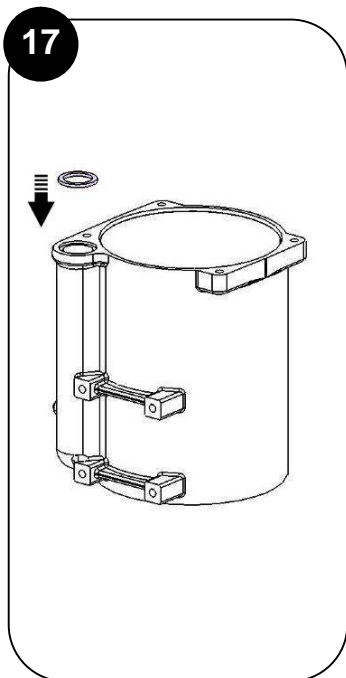
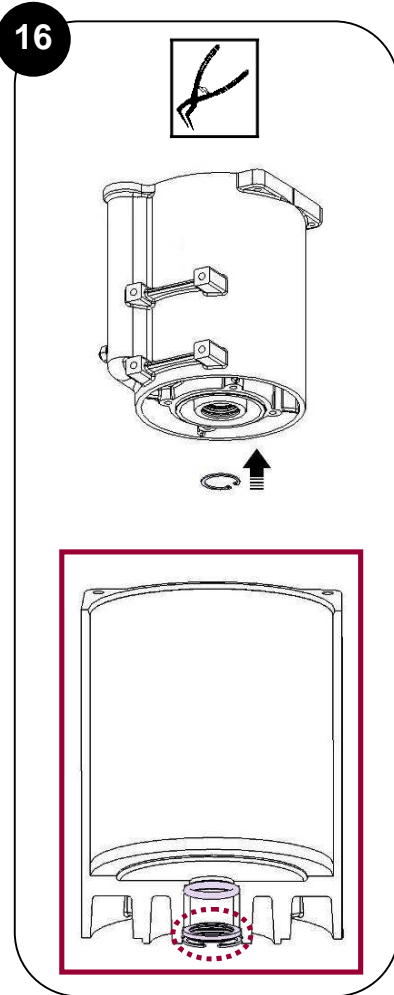
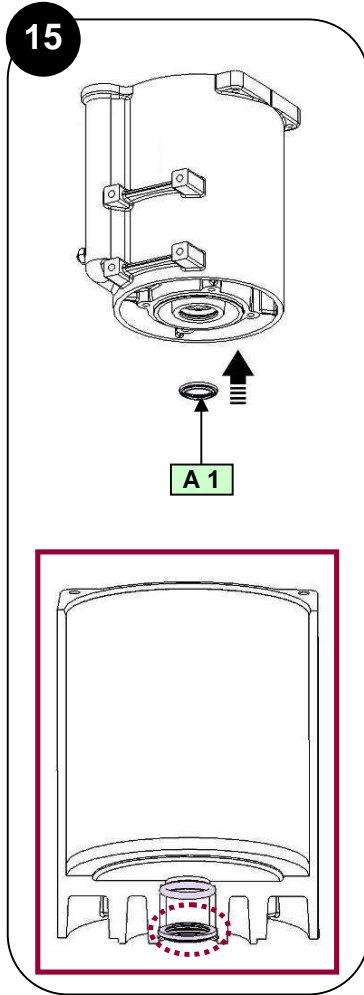
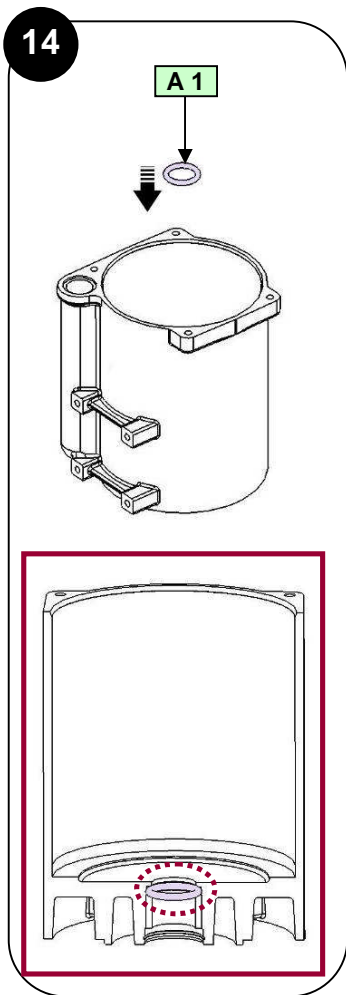

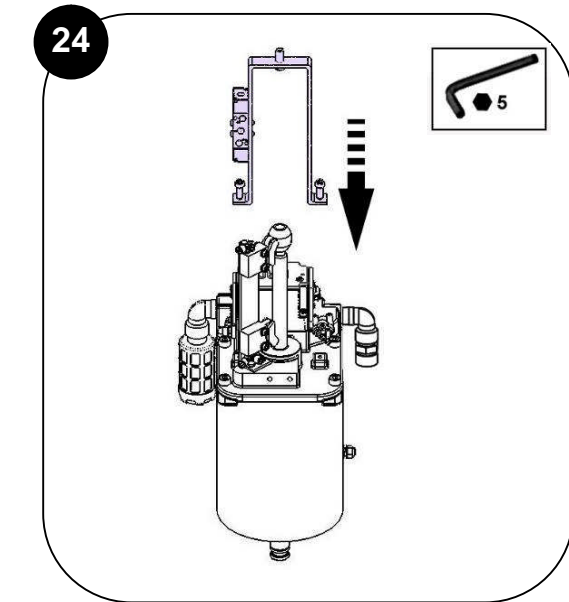
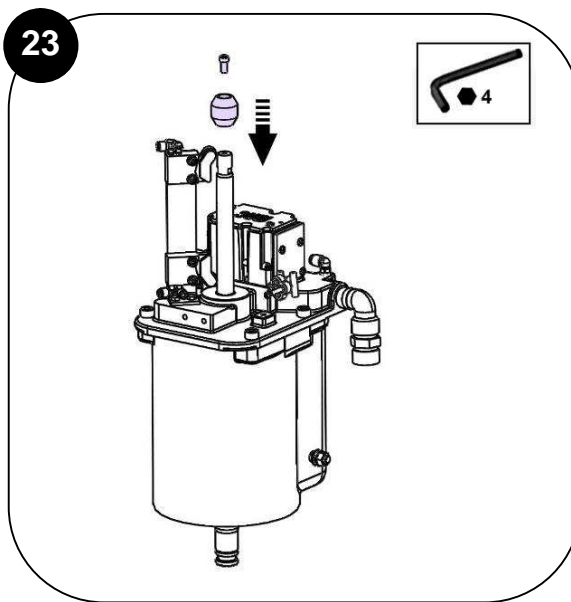
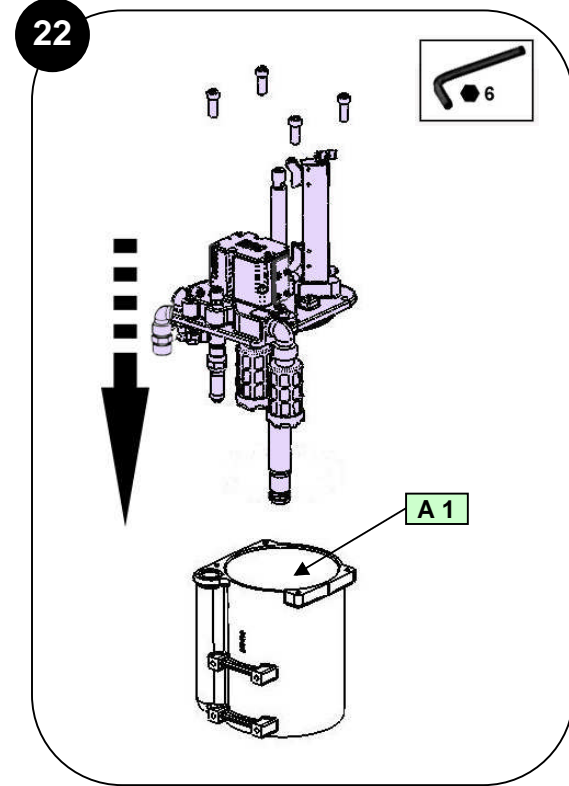
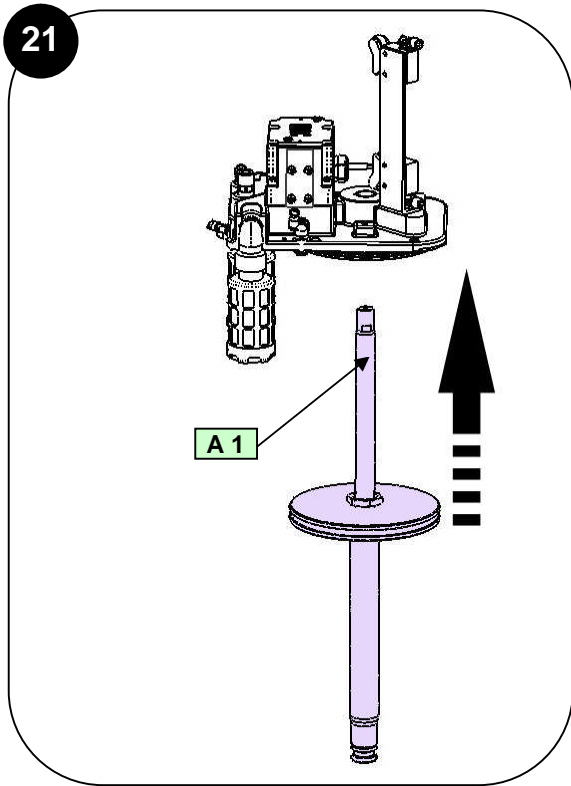
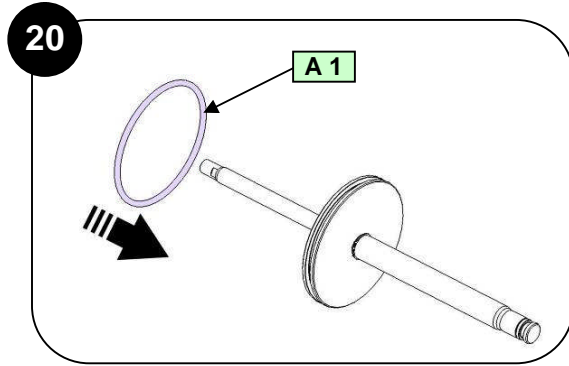
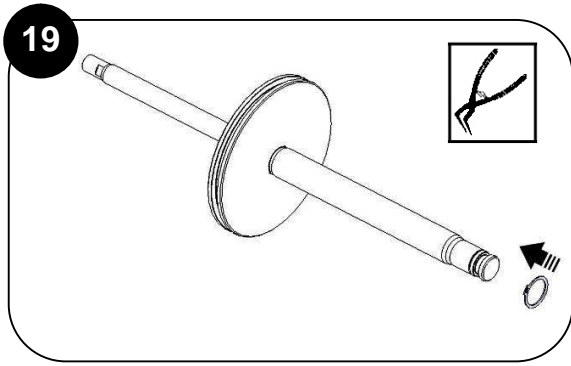

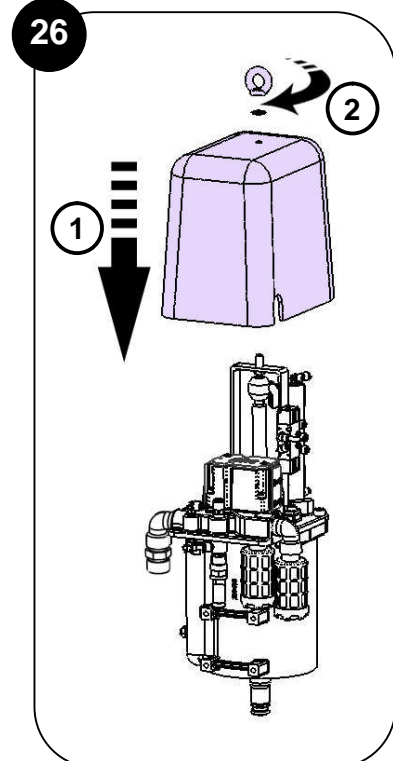
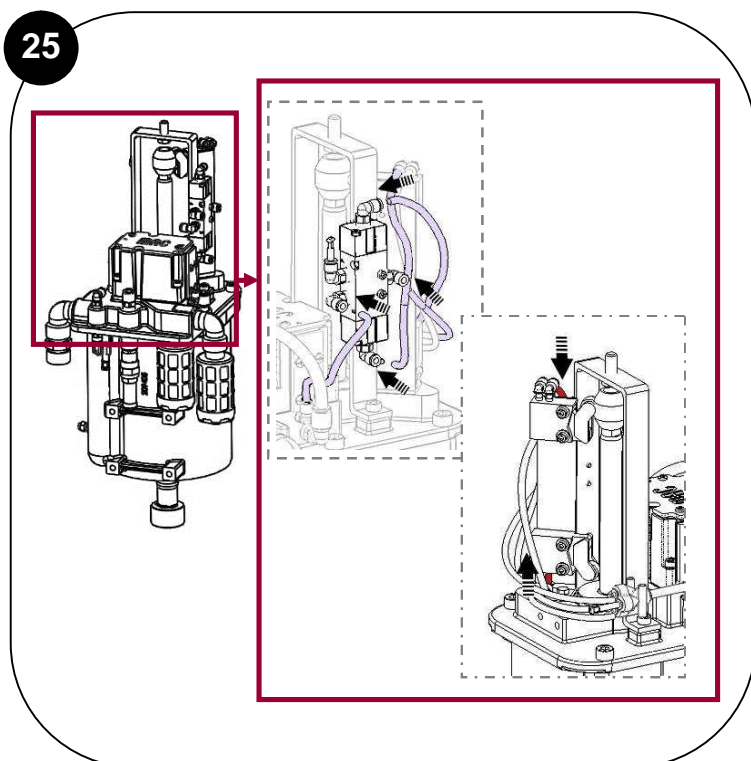

**Des protecteurs (capot moteur, protecteur d'accouplement, carters,...) sont mis en place pour une utilisation sûre du matériel.**  
**Le fabricant ne peut être tenu pour responsable en cas de dommages corporels ainsi que des pannes et / ou endommagement du matériel résultant de la destruction, de l'occultation ou du retrait total ou partiel des protecteurs.**  
*/ Guards (air motor cover, coupling shields, housings ...) have been designed for safe use of the equipment. The manufacturer will not be held responsible for bodily injury or failure and / or damage to property due to the removal or partial removal of the guards.*  
*/ Schutzvorrichtungen an diesem Gerät, wie Motorhaube, Kupplungsschutz, Gehäuse, ggf. Erdungskabel, sowie weitere Vorrichtungen, wurden für eine sichere Benutzung dieses Gerätes entwickelt und angebracht. Der Hersteller lehnt jede Verantwortung für Körperschäden, Fehlfunktionen, Beschädigung der Geräte und jegliche andere Fehler ab, die durch die ganze oder teilweise Entfernung Modifikation oder unsachgemäße Handhabung der Schutzvorrichtungen oder anderer Geräteteile entstehen.*  
*/ Protectores (capó motor, protector de acoplamiento, cárteres,...) se colocan para una utilización segura del material. El fabricante no se hace responsable, en caso de daños y / o daños del material, resultantes de la destrucción, la ocultación o la retirada total o parcial de los protectores.*



**DEMONTAGE / REMONTAGE  
DISASSEMBLY / REASSEMBLY  
DEMONTAGE / MONTAGE  
DESMONTAJE / MONTAJE**

**HYDRAULIQUE A PALETTE  
/ SHOVEL FLUID SECTION  
/ SCHÖPFKOLBENHYDRAULIKTEIL  
/ HIDRÁULICA CON PALETA  
THOR 60 & 106 cc / 2.02 & 3.58 oz**

**NOTICE ORIGINALE  
/ TRANSLATION FROM THE ORIGINAL MANUAL  
/ ÜBERSETZUNG DER ORIGINAL BEDIENUNGSANLEITUNG  
/ TRADUCCIÓN DEL LIBRO ORIGINAL**

**La pompe est soumise à la directive ATEX et ne doit en aucun cas être modifiée.  
Le non-respect de cette préconisation ne saurait engager notre responsabilité.  
/ The pump is manufactured under the ATEX agreement and can not be modified.  
KREMLIN REXSON will not be held responsible for any failure to comply with that  
instruction.**

**/ Diese Pumpe hat die ATEX Zulassung, deswegen darf sie nie verändert werden.  
Bie Nichtbeachtung dieser Anordnung, können wir keine Verantwortung für eine  
einwandfreie, regelkonforme Funktion der Pumpe übernehmen.**

**/ La bomba es de conformidad a la directiva ATEX y no debe ser modificada, en ningún  
caso. KREMLIN REXSON no se hace responsable de que esta preconización no sea  
respetada.**

**Des protecteurs (capot moteur, protecteur d'accouplement, carters,...) sont mis en place  
pour une utilisation sûre du matériel.**

**Le fabricant ne peut être tenu pour responsable en cas de dommages corporels ainsi que  
des pannes et / ou endommagement du matériel résultant de la destruction, de l'occultation  
ou du retrait total ou partiel des protecteurs.**

**/ Guards (air motor cover, coupling shields, housings ...) have been designed for safe use  
of the equipment. The manufacturer will not be held responsible for bodily injury or failure  
and / or damage to property due to removal or partial removal of the guards.**

**/ Schutzvorrichtungen an diesem Gerät, wie Motorhaube, Kupplungsschutz, Gehäuse, ggf.  
Erdungskabel, sowie weitere Vorrichtungen, wurden für eine sichere Benutzung dieses  
Gerätes entwickelt und angebracht. Der Hersteller lehnt jede Verantwortung für  
Körperschäden, Fehlfunktionen, Beschädigung der Geräte und jegliche andere Fehler ab, die  
durch die ganze oder teilweise Entfernung Modifikation oder unsachgemäße Handhabung der  
Schutzvorrichtungen oder anderen Geräteteile entstehen.**

**/ Protectores (capó motor, protector de acoplamiento, cárteres,...) se colocan para una  
utilización segura del material. El fabricante no se hace responsable, en caso de daños  
personales, así como de las averías y / o daños del material, resultantes de la destrucción, la  
ocultación o la retirada total o parcial de los protectores.**



***Vous aurez besoin de / you need / Werkzeugaufstellung / Vd necesita***



***Graisses et colles / Greases and adhesives  
/ Fette und Kleber / Grasas y colas***

<b>Repère / Index / Pos. / Índice</b>	<b>Instructions / Montage-Hinweis / Instrucciones</b>	<b>Désignation / Description / Bezeichnung / Descripción</b>	<b>Référence / Part number / Artikel-Nr. / Referencia</b>
<b>A 1</b>	Graisse PTFE	Tube de graisse "TECHNILUB" (10 ml)	560.440.101
	PTFE grease	PTFE grease (10 ml / 0.0026 US gal)	
	PTFE-Fett	PTFE Fett (10 ml)	
	Grasa PTFE	Tubo de grasa "TECHNILUB" (10 ml)	
<b>A 2</b>	Graisse anti-seize	Boîte de graisse (450 g)	560.420.005
	Anti-seize grease	Grease box (450 g / 0.99 lb)	
	Grafit Fett	Grafit Fett (450 g Dose)	
	Grasa anti-seize	Caja de grasa anti-seize (450 g)	
<b>C 1</b>	Colle Anaérobie Tube étanche	Loctite 577 (250 ml)	554.180.015
	Medium strength Aneorobic Pipe sealant	Loctite 577 (250 ml / 0.066 US gal)	
	Mittelfester anaerober Kleber	Loctite 577 (250 ml)	
	Cola PTFE (para la estanqueidad)	Loctite 577 (250 ml)	

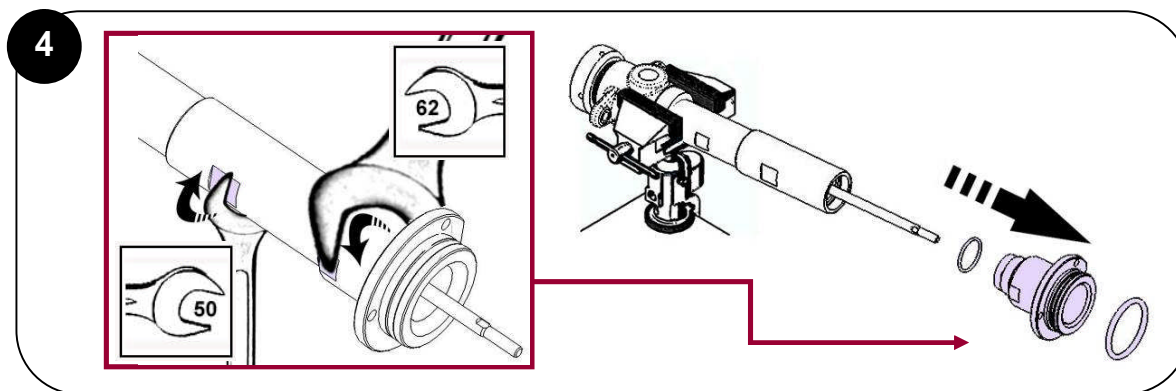
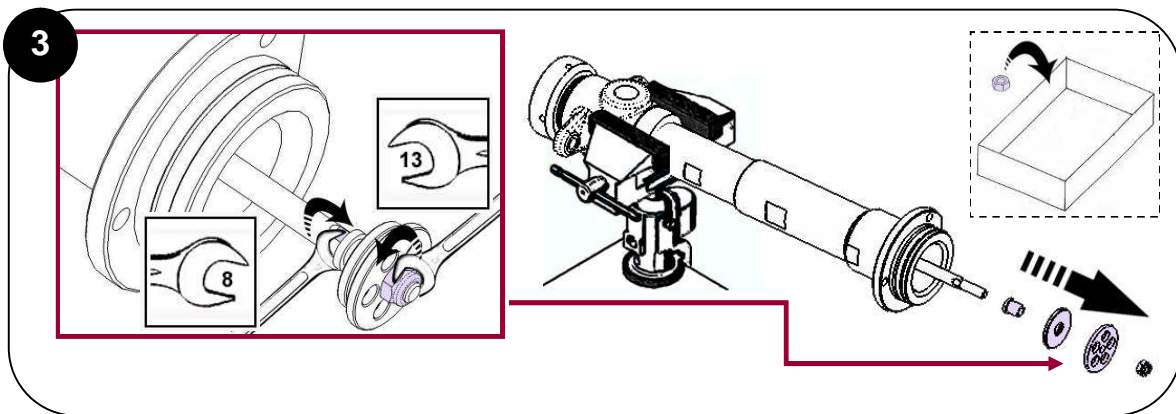
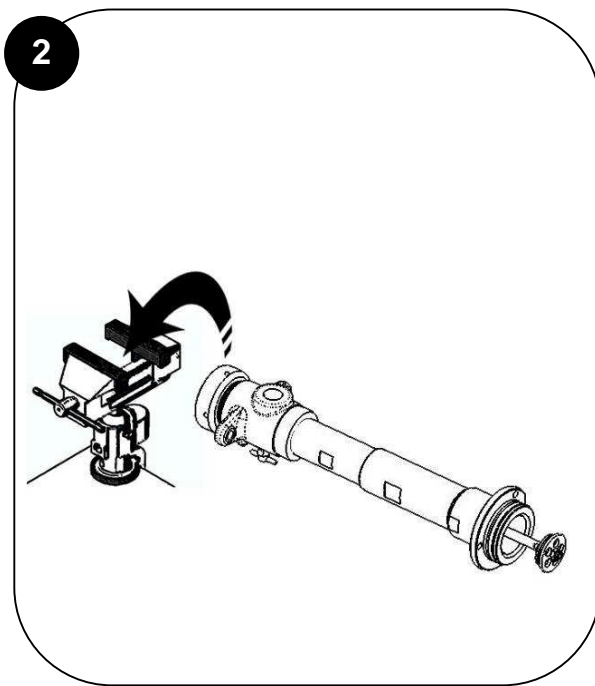
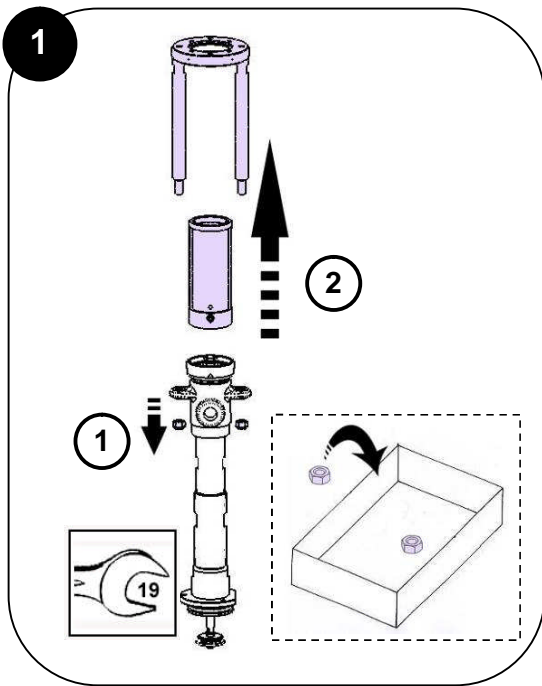

5

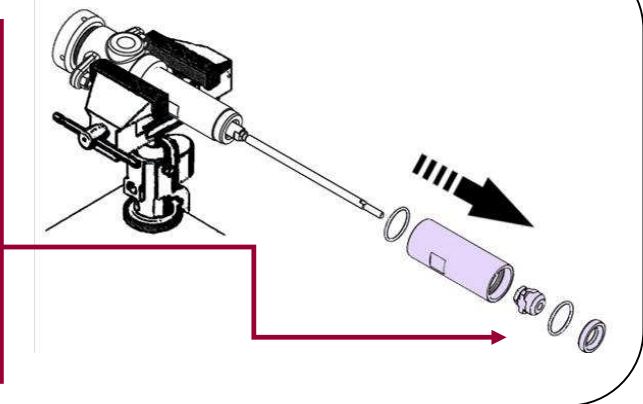
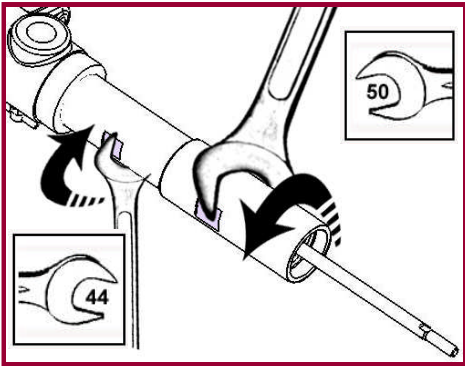

6

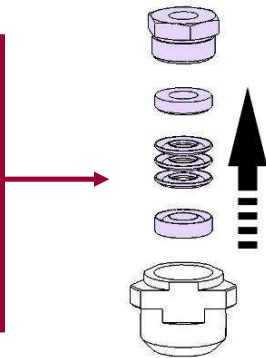
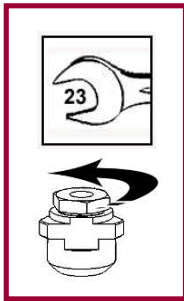

7

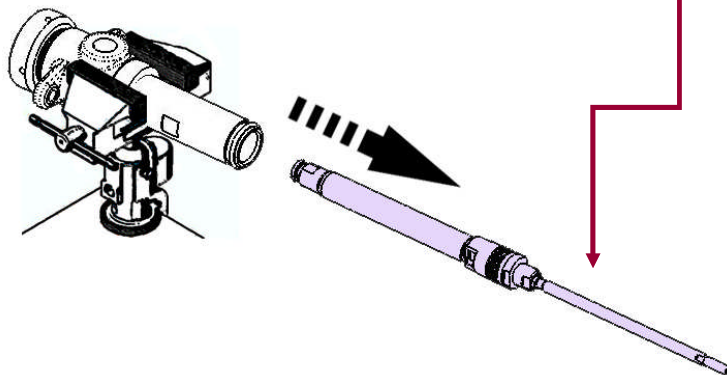
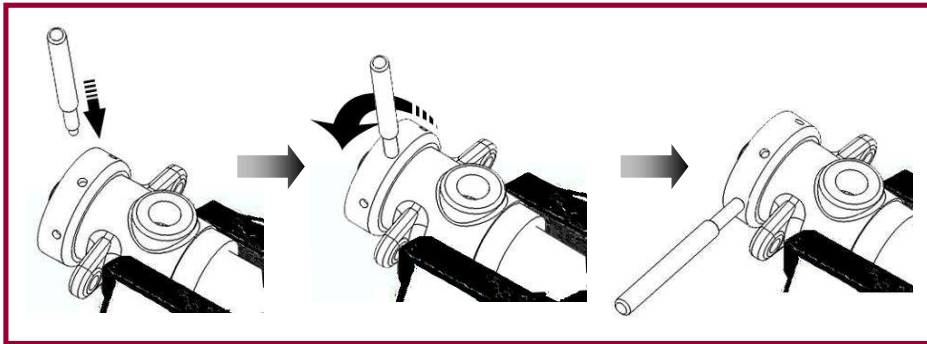

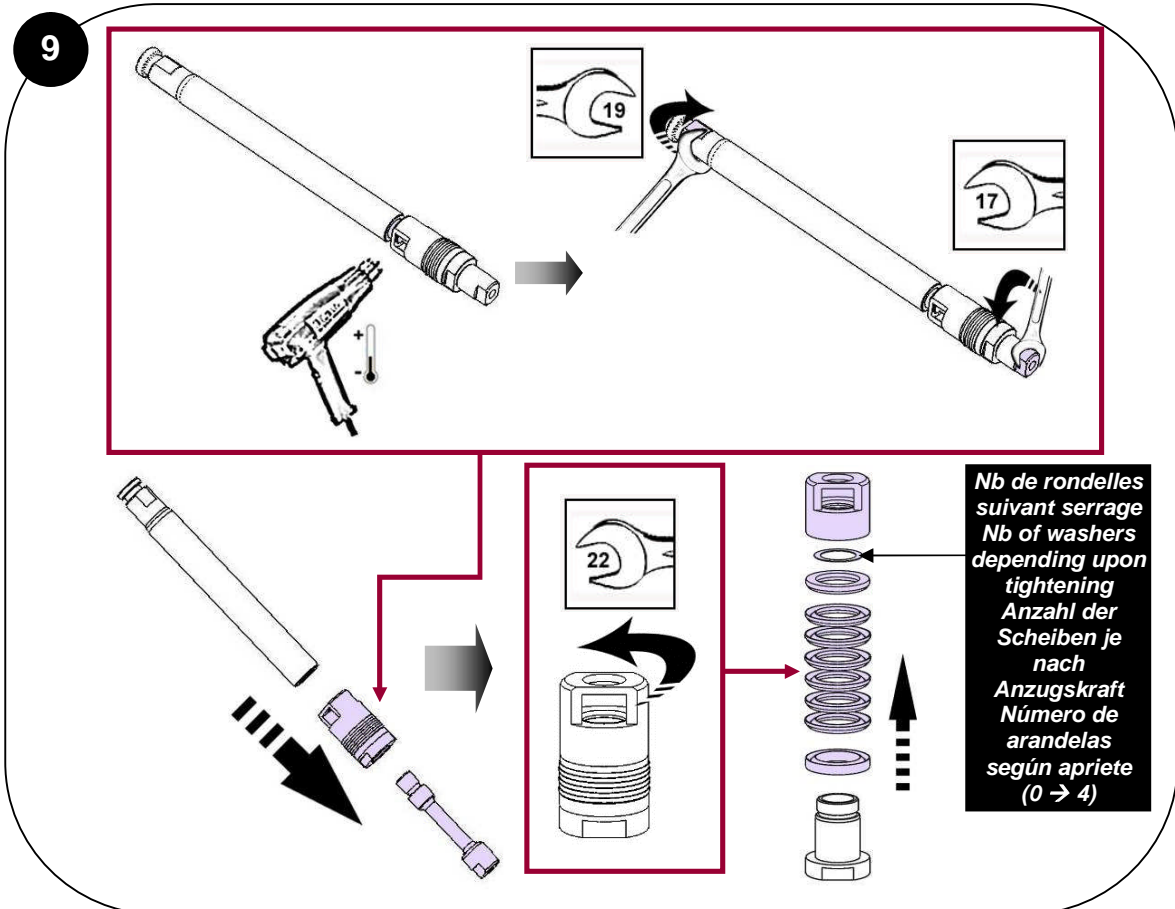
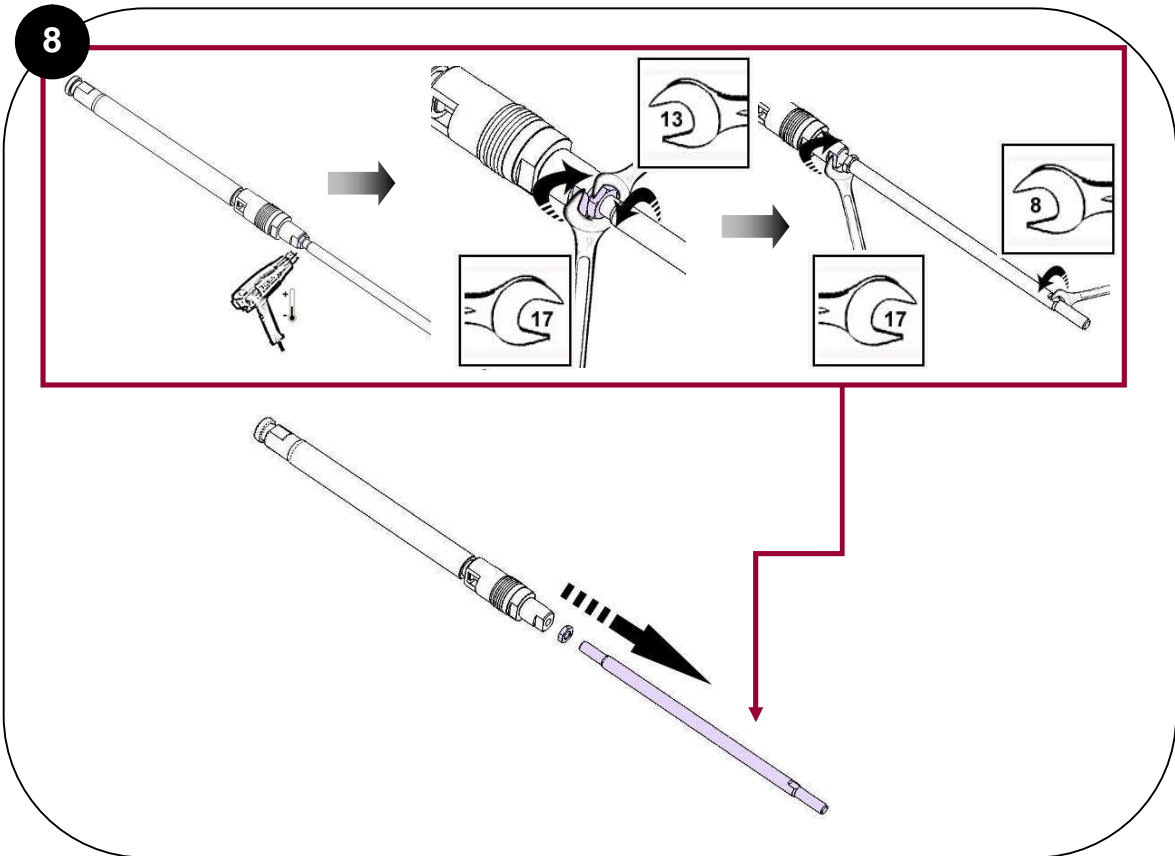

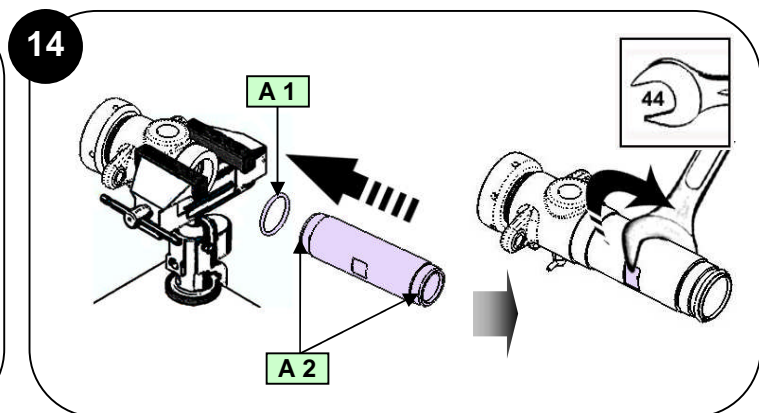
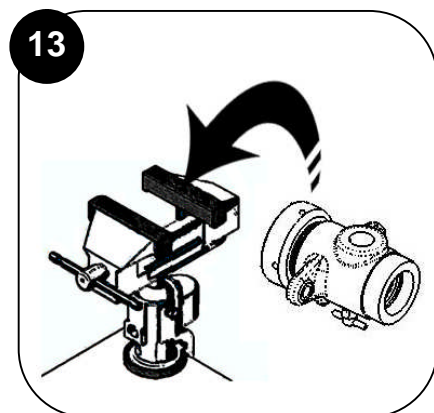
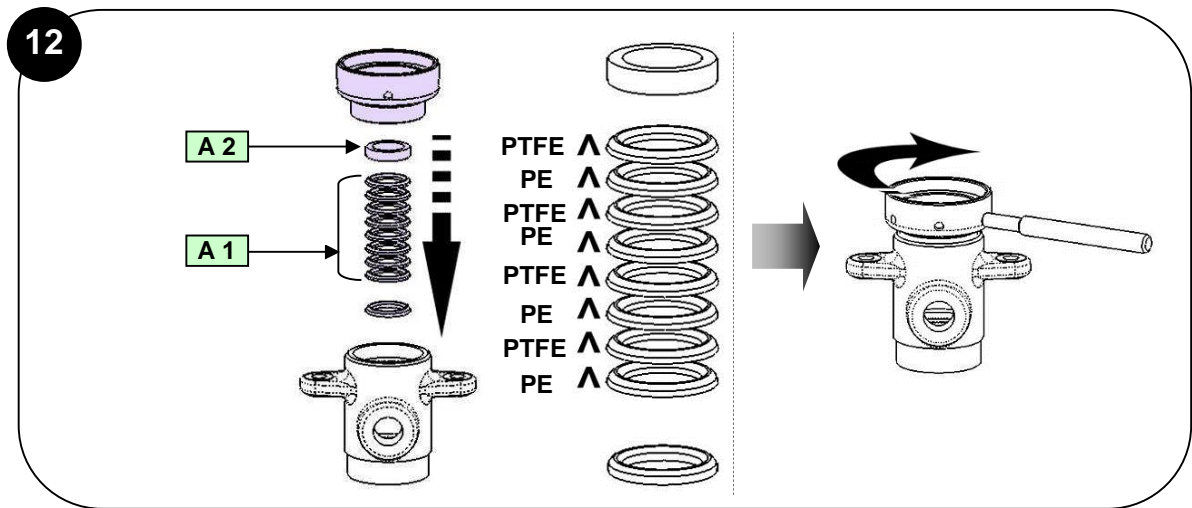
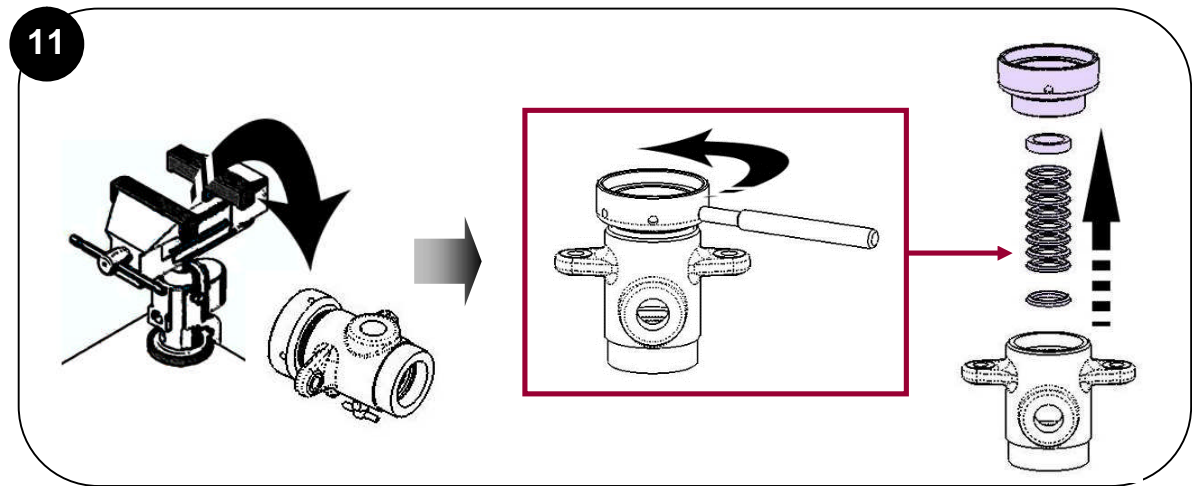
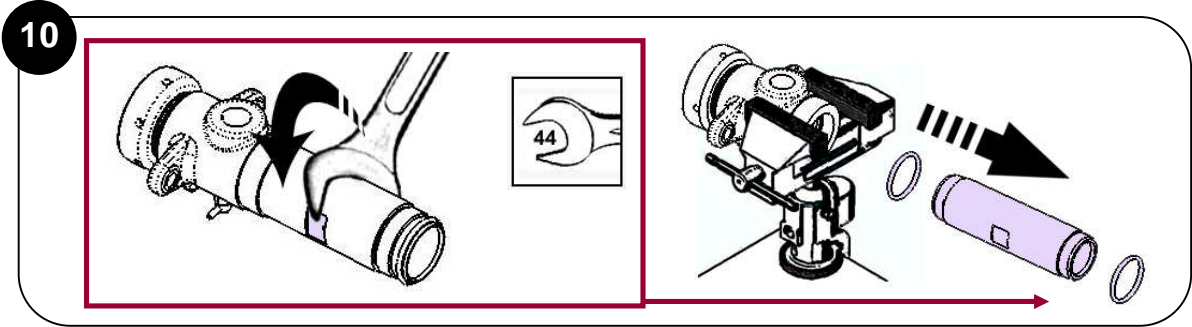

15

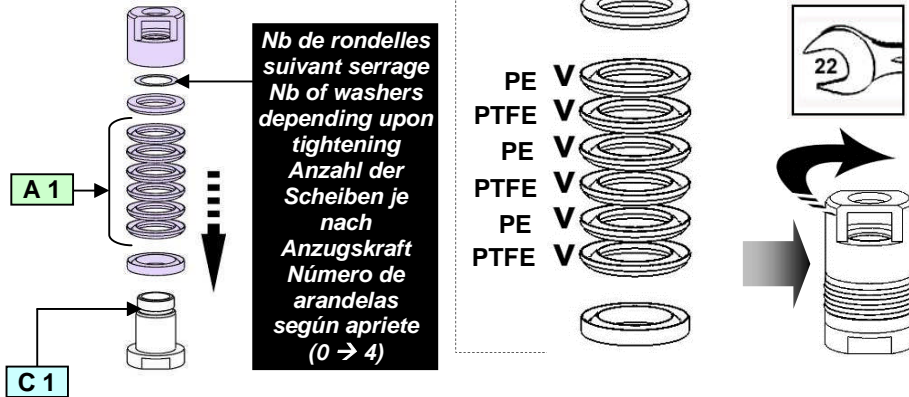

16

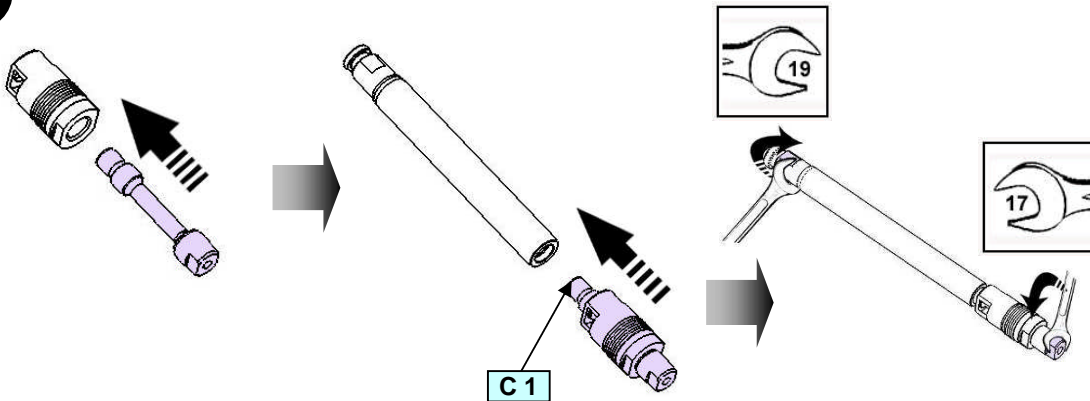

17

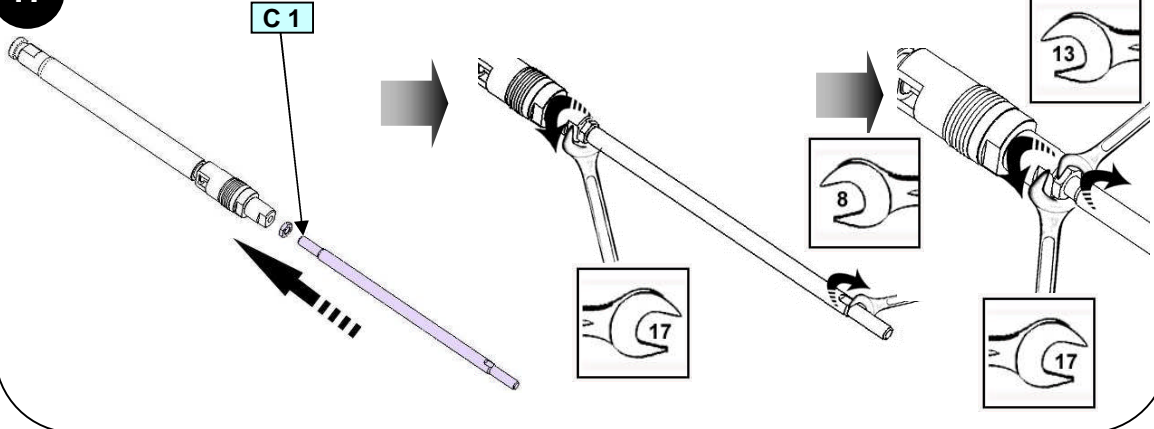

18

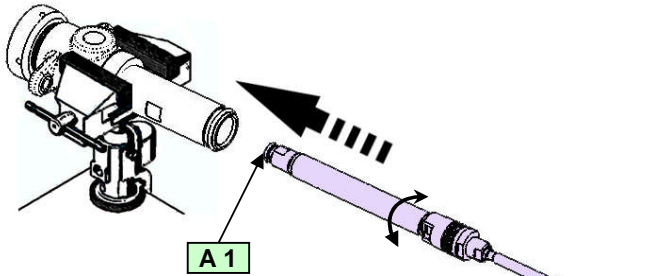

Avec précaution, introduire le piston dans le corps de l'hydraulique en faisant un mouvement de rotation de façon à préformer le joint.  
*Carefully, insert the piston into fluid section body carrying out a rotary motion so as to preformate the seal.*  
 Schieben Sie Vorsichtig, mit einer Drehenden Bewegung, Den Kolben in das Hydrauliteil ein, um die Dichtungen Vorzuformen  
 Con cuidado, introducir el piston en el cuerpo de la hidráulica con un movimiento de rotación para preformar la junta.

19

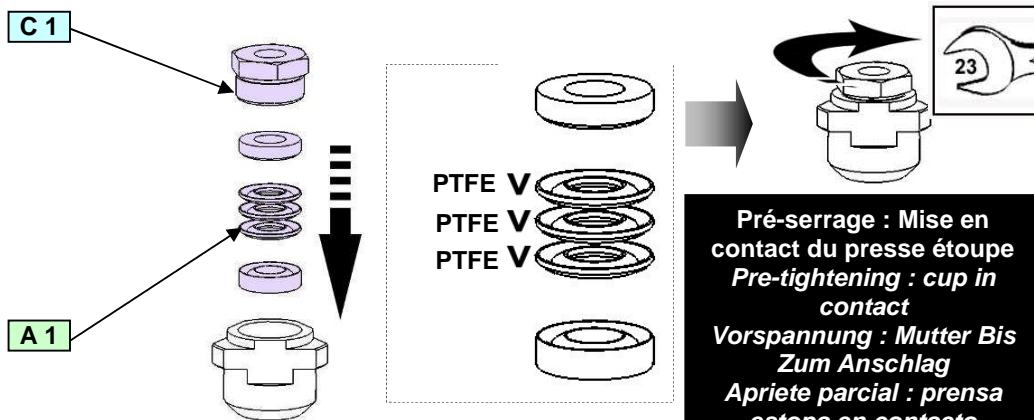

Pré-serrage : Mise en contact du presse étoupe  
 Pre-tightening : cup in contact  
 Vorspannung : Mutter Bis Zum Anschlag  
 Apriete parcial : prensa estopa en contacto

20

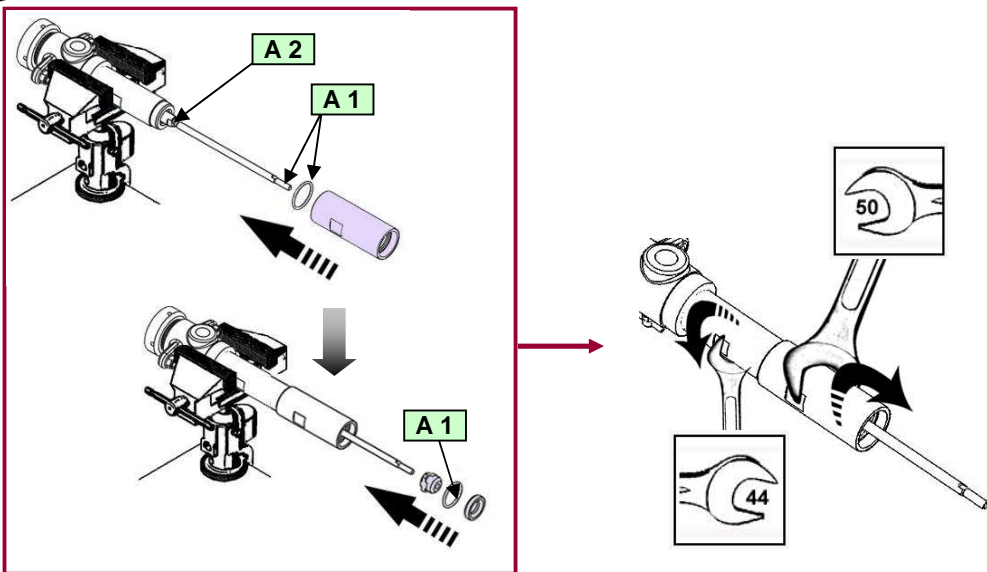

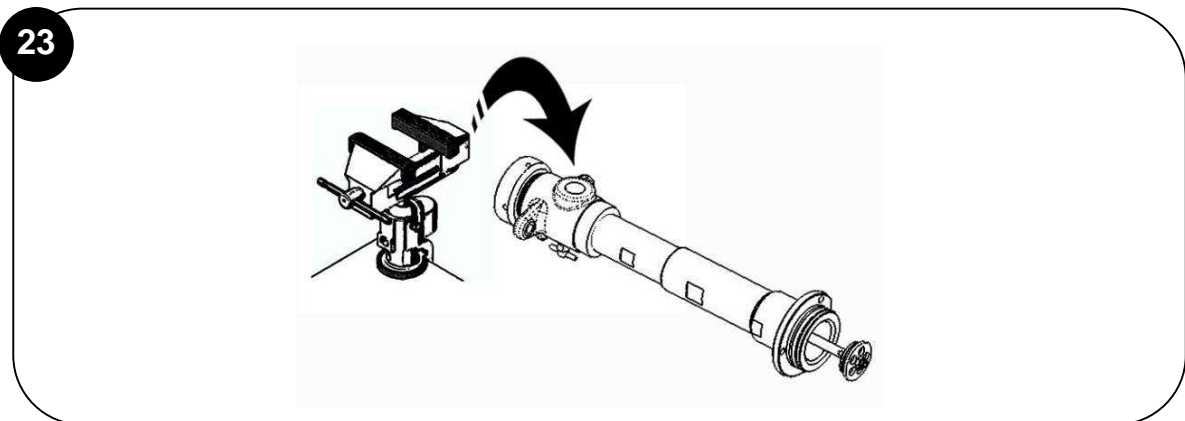
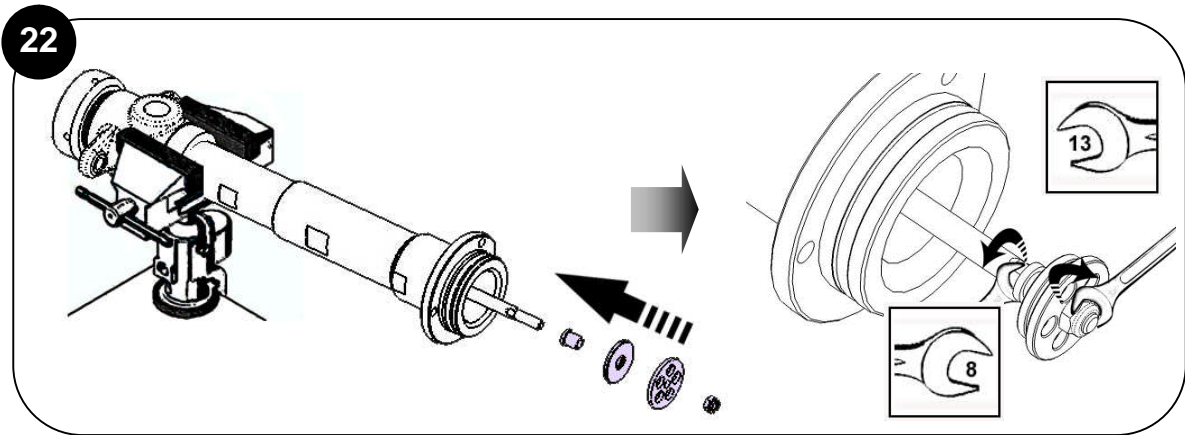
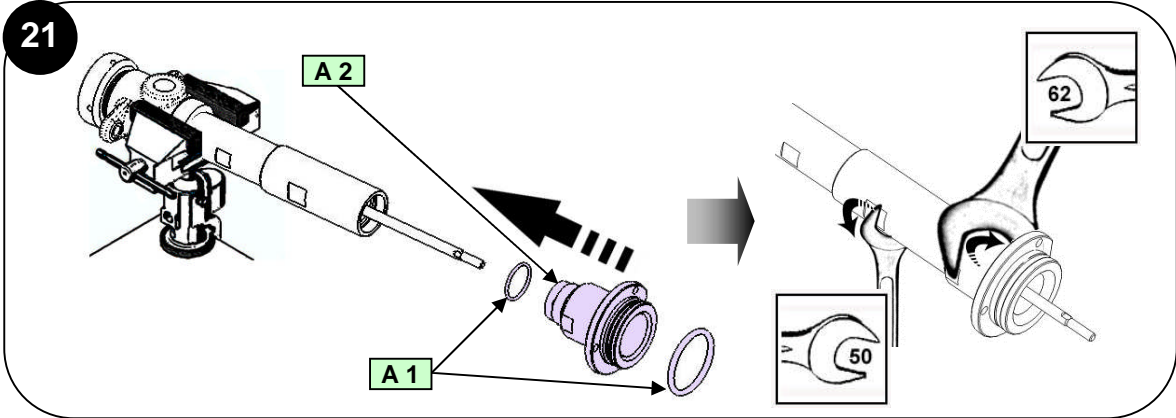



24

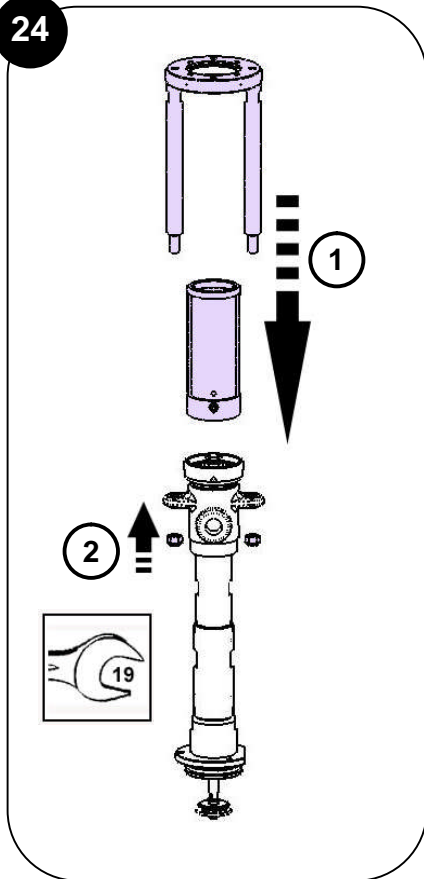

Des protecteurs (capot moteur, protecteur d'accouplement, carters,...) sont mis en place pour une utilisation sûre du matériel.

Le fabricant ne peut être tenu pour responsable en cas de dommages corporels ainsi que des pannes et / ou endommagement du matériel résultant de la destruction, de l'occultation ou du retrait total ou partiel des protecteurs.

/ Guards (air motor cover, coupling shields, housings ... ) have been designed for safe use of the equipment.



The manufacturer will not be held responsible for bodily injury or failure and / or damage to property due to the removal or partial removal of the guards.



/ Schutzvorrichtungen an diesem Gerät, wie Motorhaube, Kupplungsschutz, Gehäuse, ggf. Erdungskabel, sowie weitere Vorrichtungen, wurden für eine sichere Benutzung dieses Gerätes entwickelt und angebracht. Der Hersteller lehnt jede Verantwortung für Körperschäden, Fehlfunktionen, Beschädigung der Geräte und jegliche andere Fehler ab, die durch die ganze oder teilweise Entfernung Modifikation oder unsachgemäße Handhabung der Schutzvorrichtungen oder anderer Geräteteile entstehen.

/ Protectores (capó motor, protector de acoplamiento, cárteres,...) se colocan para una utilización segura del material. El fabricante no se hace responsable, en caso de daños y / o daños del material, resultantes de la destrucción, la ocultación o la retirada total o parcial de los protectores.

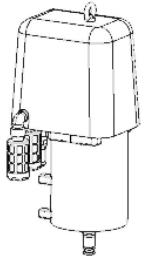
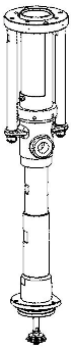
# PIECES DE RECHANGE SPARE PARTS

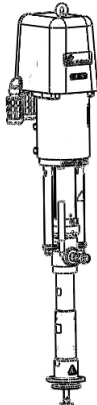
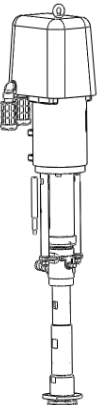
## Pompes à palette / Shovel pumps THOR

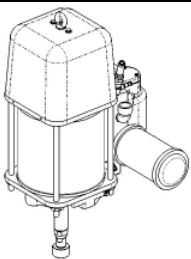
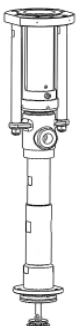
<b>MOTEUR / MOTOR 3000</b>	
	
<p>↪ Se reporter à doc. / Refer to doc 578.093.110 146 310 000</p>	
<b>HYDRAULIQUES / FLUID SECTIONS</b>	
<b>60 CC</b>	<b>106 CC 34/1</b>
	
<p>↪ Se reporter à doc. / Refer to doc 578.097.110 144 200 000</p>	<p>↪ Se reporter à doc. / Refer to doc 578.098.110 144 210 000</p>
↓	↓
<b>POMPES / PUMPS</b>	
<b>60.60</b>	<b>34.106</b>
	
151 040 000	151 050 000

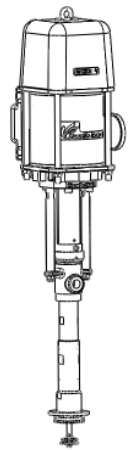
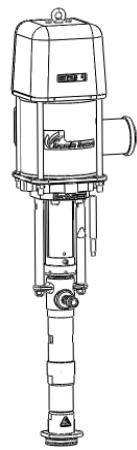
<b>MOTEUR / MOTOR 5000</b>	
	
<p>↗ Se reporter à doc. / Refer to doc 578.094.110 146 320 000</p>	
<b>HYDRAULIQUES / FLUID SECTIONS</b>	
<b>106 CC 63/1</b>	<b>207 CC</b>
	
<p>↗ Se reporter à doc. / Refer to doc 578.098.110 144 210 500</p>	<p>↗ Se reporter à doc. / Refer to doc 578.100.110 144 220 000</p>
↓	↓
<b>POMPES / PUMPS</b>	
<b>63.106</b>	<b>32.207</b>
	
<b>151 050 500</b>	<b>151 060 000</b>

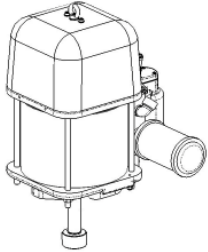
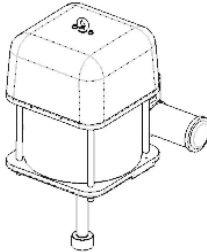
<b>MOTEUR / MOTOR 7000</b>	<b>MOTEUR / MOTOR 9000</b>
	
<p>↪ Se reporter à doc. / Refer to doc 578.095.110 146 330 000</p>	<p>↪ Se reporter à doc. / Refer to doc 578.096.110 146 340 000</p>

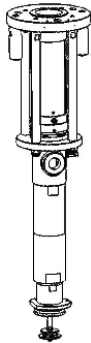
<b>HYDRAULIQUE / FLUID SECTION</b>	
<b>216 CC</b>	
	
<p>↪ Se reporter à doc. / Refer to doc 578.101.110 144 230 000</p>	

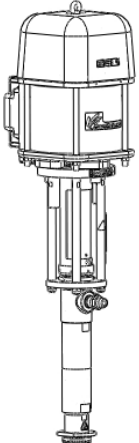
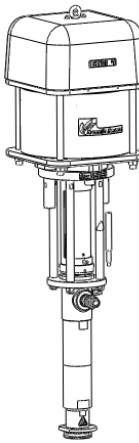
<b>POMPES / PUMPS</b>	
<b>53.216</b>	<b>82.216</b>
	
<b>151 070 000</b>	<b>151 070 500</b>

**PIECES DE RECHANGE  
SPARE PARTS  
ERSATZTEILLISTE  
PIEZAS DE REPUESTO**

**Moteur / Motor  
3000  
# 146 310 000**

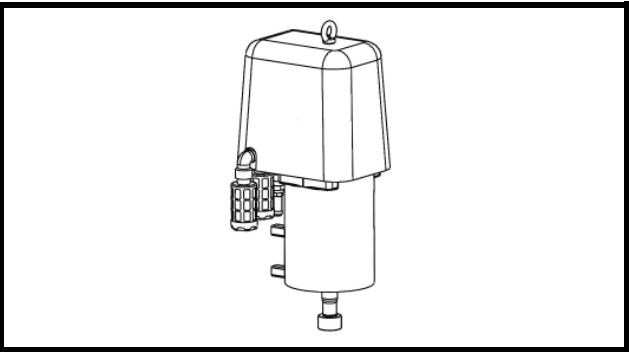

**POCHETTE DE JOINTS / SEAL KIT  
DICHTUNGSSATZ / BOLSA DE JUNTAS  
146 310 090**

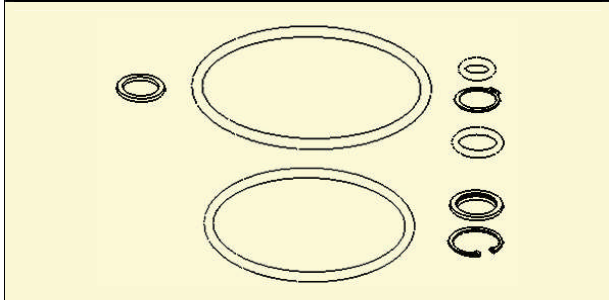

**KIT PNEUMATIQUE / PNEUMATIC KIT  
PNEUMATISCHE KIT / KIT NEUMÁTICO  
146 320 094**

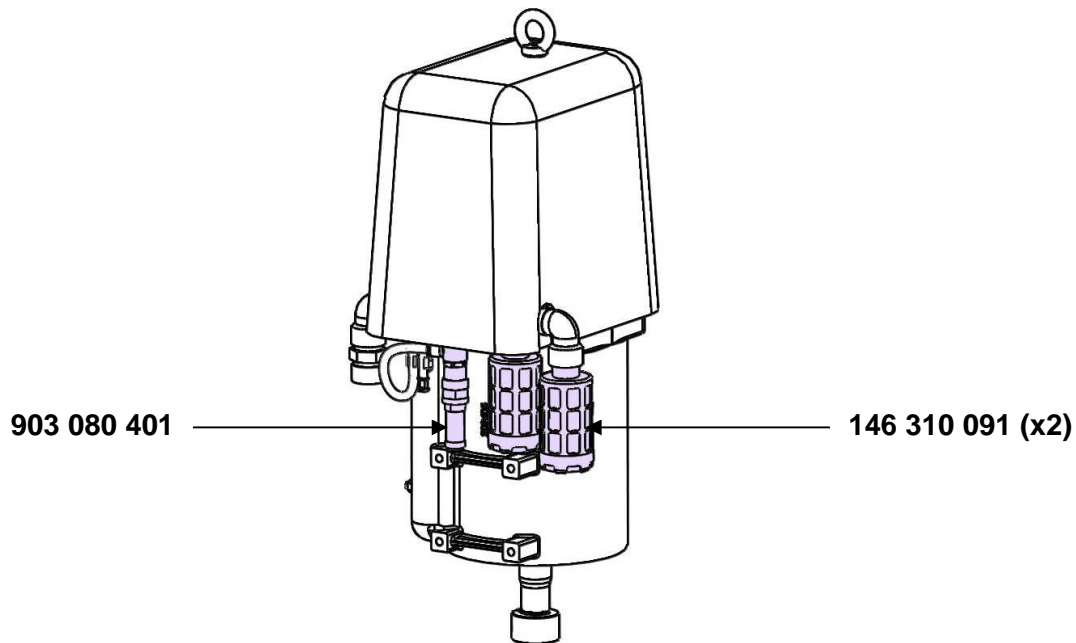
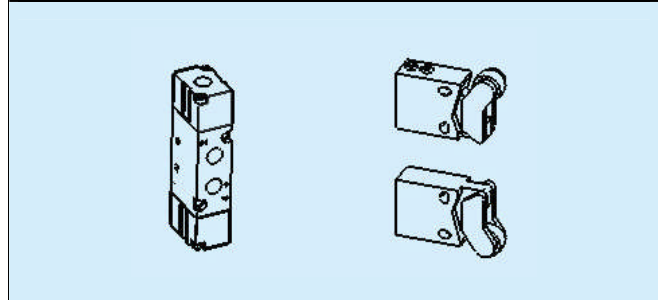

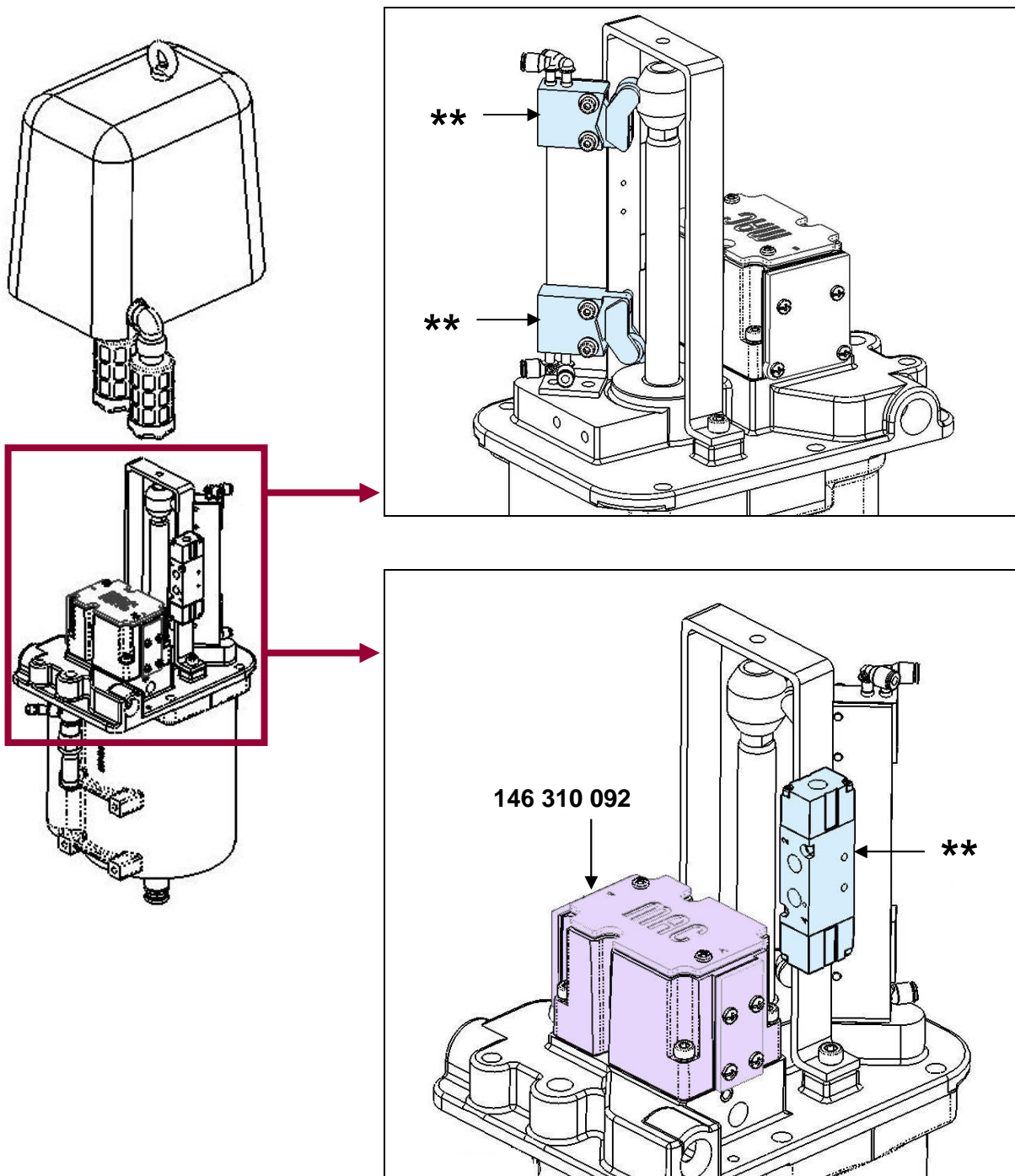

**\*\* inclus dans le kit pneumatique / included in the *pneumatic kit* / Siehe Pneumatische Kit / incluido en el kit neumático**

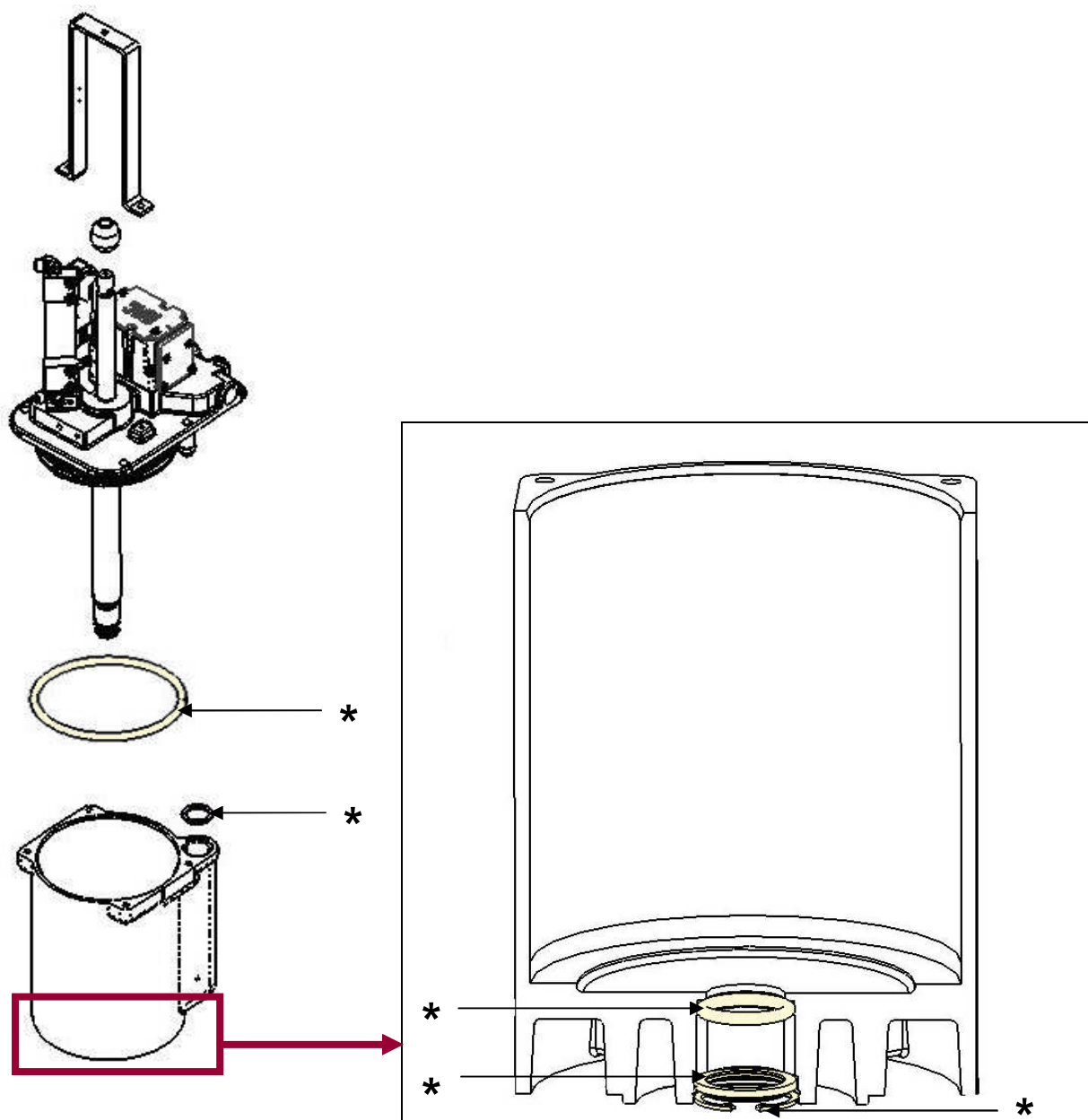

**\* inclus dans la pochette de joints / included in the seal kit  
/ Siehe Dichtungssatz / incluido en la bolsa de juntas**

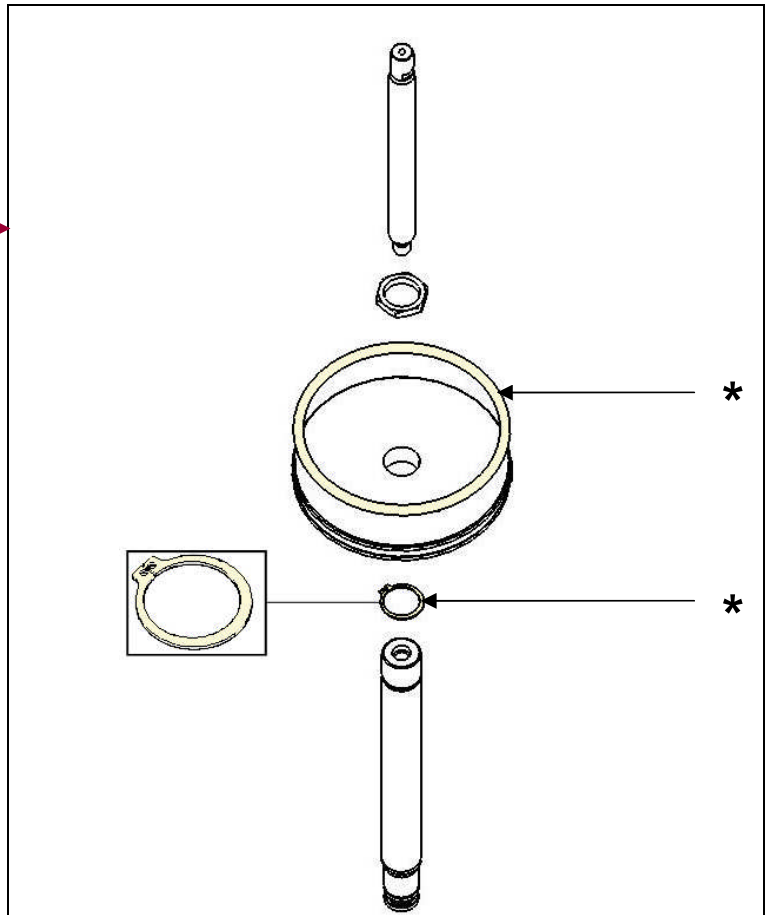
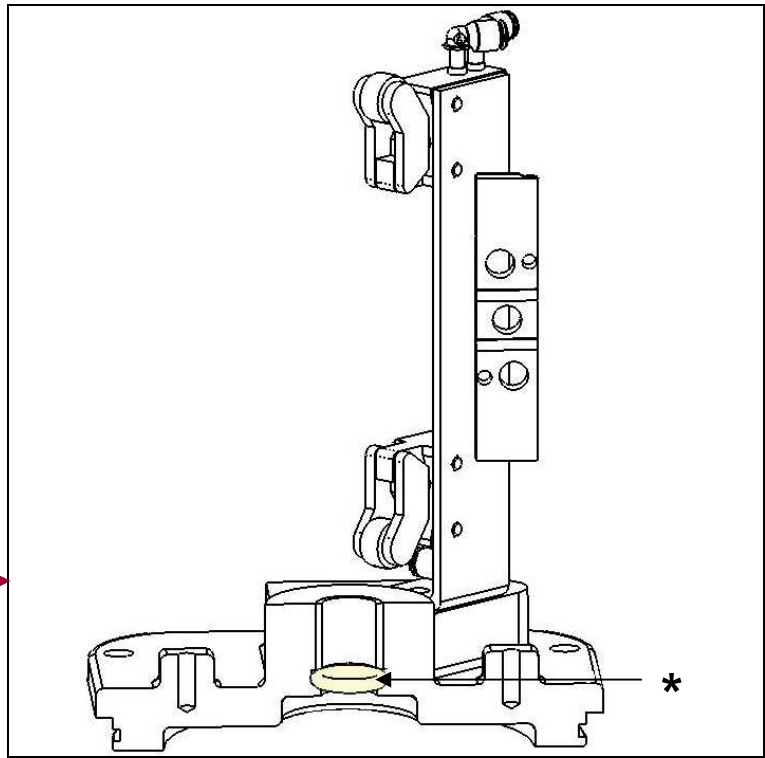
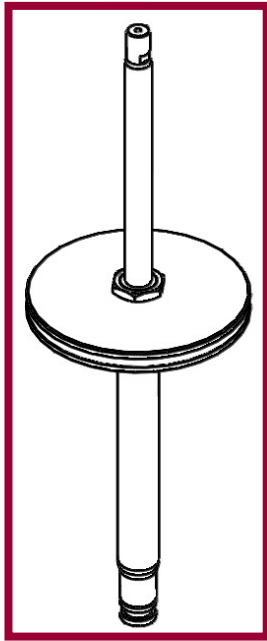
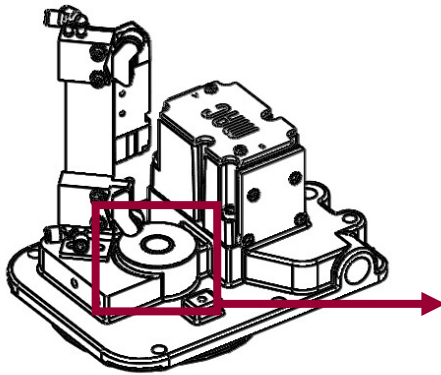

\* inclus dans la pochette de joints / included in the seal kit  
 / Siehe Dichtungssatz / incluido en la bolsa de juntas

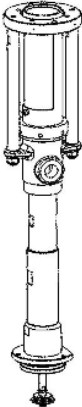
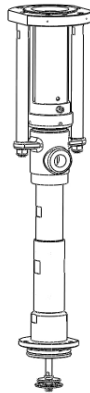

**PIECES DE RECHANGE  
SPARE PARTS  
ERSATZTEILLISTE  
PIEZAS DE REPUESTO**

<p><b>Hydraulique à palette Shovel fluid section Schöpfkolben hydraulikteil Hidráulica con paleta 106 cc / 3.58 oz.</b></p>	<p><b><u>Moteur 3000</u> <u>Motor 3000</u></b></p>	<p><b><u>Moteur 5000</u> <u>Motor 5000</u></b></p>
	<p><b># 144 210 000</b></p>	<p><b># 144 210 500</b></p>
		

**POCHETTE DE REPARATION / SERVICING KIT  
REPARATURSATZ / BOLSA DE REPARACIÓN**

**144 210 091**

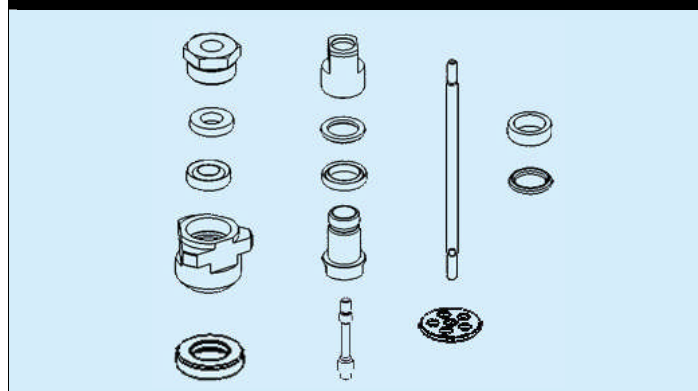

**POCHETTE DE JOINTS / SEAL KIT  
DICHTUNGSSATZ / BOLSA DE JUNTAS**

**PE / PTFE**

**144 210 090**

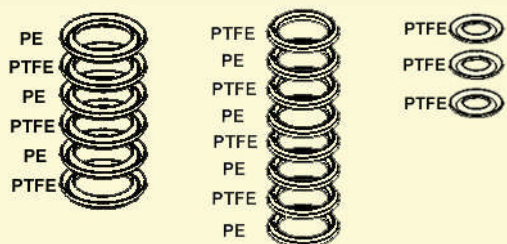

**KIT CYLINDRE / CYLINDER KIT  
ANSAUGZYLINDERKIT / KIT CILINDRO**

**144 210 092**

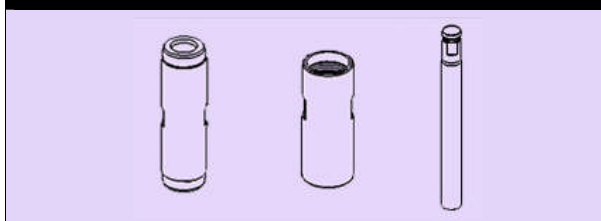

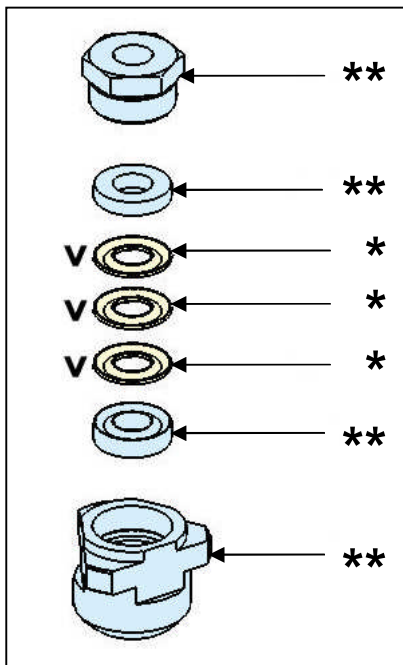
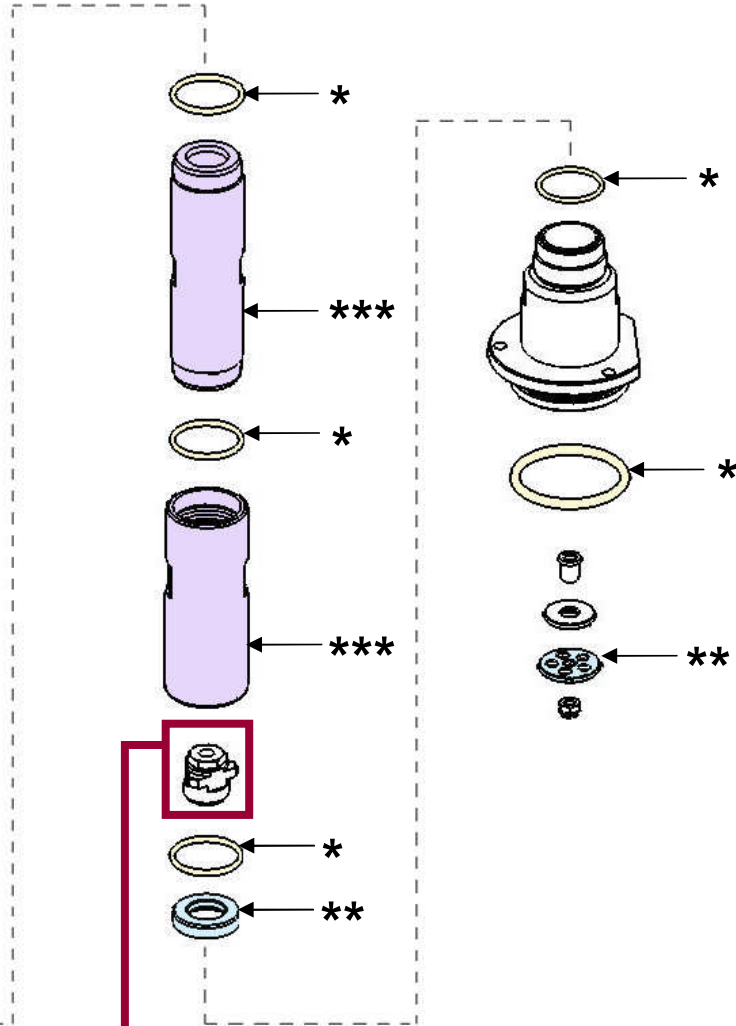
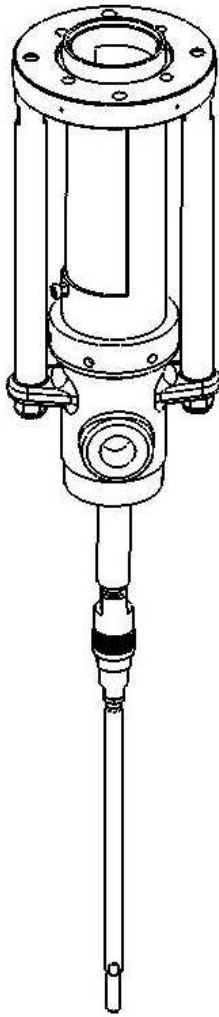

*	<b>inclus dans la pochette de joints</b> <b>included in the seal kit / Siehe Dichtungssatz</b> <b>/ incluido en la bolsa de juntas</b>
**	<b>inclus dans le kit de réparation</b> <b>included in the repair kit / Siehe reparatursatz</b> <b>/ incluido en la bolsa de reparación</b>
***	<b>inclus dans le kit cylindre</b> <b>included in the cylinder kit / Siehe Ansaugzylinderkit</b> <b>/ incluido en el kit cilindro</b>

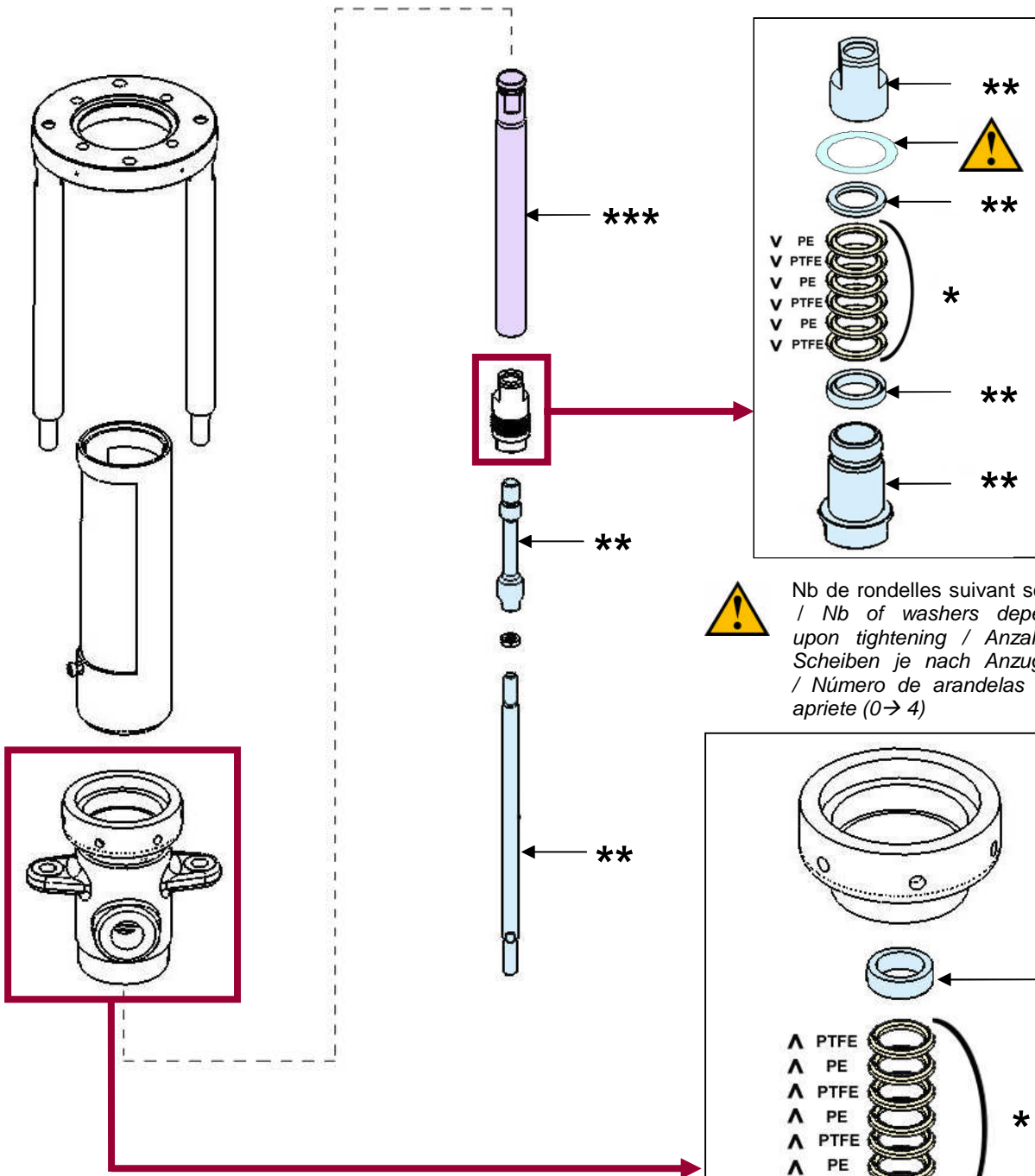

 Nb de rondelles suivant serrage  
 / Nb of washers depending upon tightening  
 / Anzahl der Scheiben je nach Anzugskraft  
 / Número de arandelas según apriete (0 → 4)

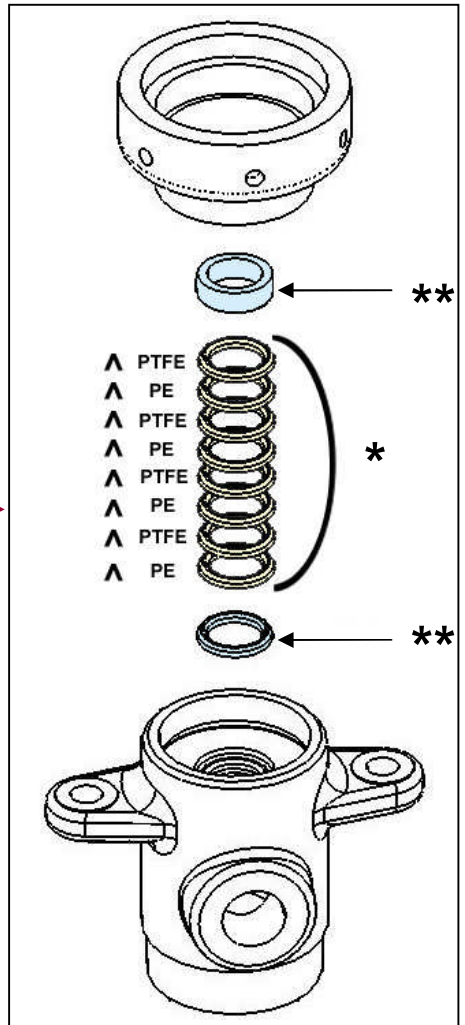

*	inclus dans la pochette de joints <i>included in the seal kit / Siehe Dichtungssatz</i> <i>/ incluido en la bolsa de juntas</i>
**	inclus dans le kit de réparation <i>included in the repair kit / Siehe reparatursatz</i> <i>/ incluido en la bolsa de reparación</i>
***	inclus dans le kit cylindre <i>included in the cylinder kit / Siehe Ansaugzylinderkit</i> <i>/ incluido en el kit cilindro</i>

EN OPTION / OPTIONAL / OPTIONEN / OPCIÓN

**POCHETTE DE JOINTS / SEAL KIT**  
**DICHTUNGSSATZ / BOLSA DE JUNTAS**

**PTFE G / PTFE**

**144 210 093**

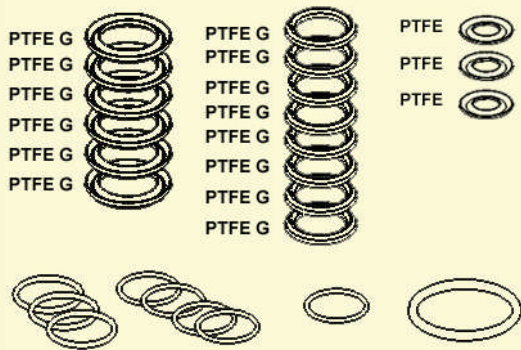

**POCHETTE DE JOINTS / SEAL KIT**  
**DICHTUNGSSATZ / BOLSA DE JUNTAS**

**PTFE G / PU / PTFE**

**144 210 094**

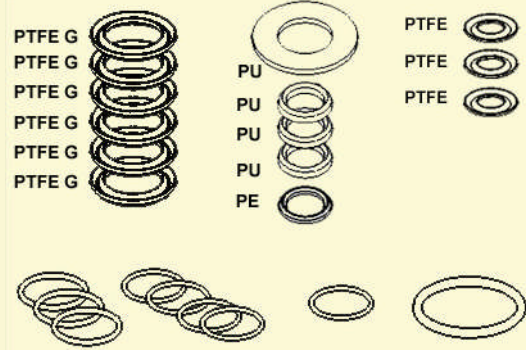

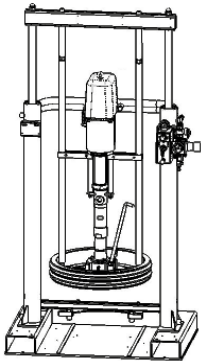
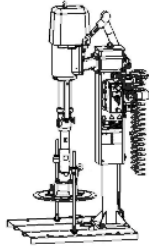
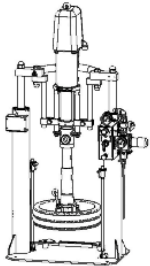

## **EXTRUSION UNITS**

### ***THOR***

#### ***PREVENTIVE MAINTENANCE***

#### **TRANSLATION OF THE ORIGINAL MANUAL**

***IMPORTANT : Before assembly and start-up, please read and clearly understand all the documents relating to the equipment (professional use only).***

THE PICTURES AND DRAWINGS ARE NOT CONTRACTUAL. WE RESERVE THE RIGHT TO MAKES CHANGES WITHOUT PRIOR NOTICE.

#### **KREMLIN - REXSON**

150, avenue de Stalingrad

93 245 - STAINS CEDEX – France

☎ : 33 (0)1 49 40 25 25      Fax : 33 (0)1 48 26 07 16

**[www.kremlin-rexson.com](http://www.kremlin-rexson.com)**

OPERATION TO CARRY OUT	FREQUENCY					
	D	W	M	Q	H	Y
<b>GENERAL</b>						
Check earthings	X					
Check leakage from the fittings		X				
Check hoses			X			
Operate the valves			X			
<b>PUMP</b>						
Clean the pistons of the pumps (do not let the material dry)		X				
Check piston rod tightness		X				
Check there is no leak at the upper cartridge		X				
Check the tightness of the upper cartridge (pump stopped and without air on the motor; depressurize the network)			X			
<b>Caution : flush the pump for a long duration shutdown of the installation (more than two weeks)</b>						
<b>MOTOR</b>						
Check the tightness of the piston rod					X	
Check if the control system is clean			X			
<b>FLUID SECTION</b>						
Check the tightness of the cup				X		
Check if there is lubricant in the cupel		X				
Disassemble the fluid section, clean the parts with the appropriate cleaning solvent, change the seals and the parts if necessary						X
Change the lubricant if the coloration is too important and change the seals of the upper flange if the problem persists			X			
<b>FOLLOWER PLATE</b>						
Clean the follower plate each time you replace the drum	X	X				
Lubricate the seals each time you replace the drum	X	X				
Clean the non-return valve and the drain valve			X			
D : daily W : weekly		M : monthly Q : quarterly		H : half-yearly Y : yearly		

OPERATION TO CARRY OUT	FREQUENCY					
	D	W	M	Q	H	Y
<b>RAM</b>						
Check the equipment is correctly positioned			X			
Check there is no air leakage			X			
Check the condition of the air hoses			X			
Clean the rod (high position) and lubricate them with a brush			X			
Clean and check the tightness of the seals			X			
Check the rod (s)			X			
D : daily W : weekly		M : monthly Q : quarterly		H : half-yearly Y : yearly		

**Note : Frequencies are given as a clue. They must be adapted by the maintenance service of the user for every installation according to the product, the working cadence and the working pressure.**

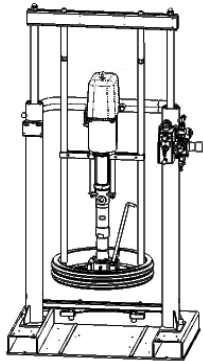
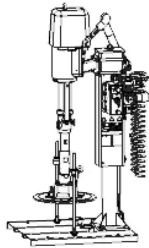
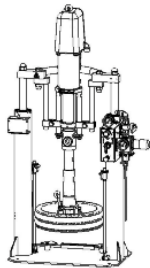

## **EXTRUSION UNITS**

### **THOR**

#### **TROUBLESHOOTING GUIDE**

### **TRANSLATION OF THE ORIGINAL MANUAL**

***IMPORTANT : Before assembly and start-up, please read and clearly understand all the documents relating to the equipment (professional use only).***

THE PICTURES AND DRAWINGS ARE NOT CONTRACTUAL. WE RESERVE THE RIGHT TO MAKE CHANGES WITHOUT PRIOR NOTICE.

#### **KREMLIN - REXSON**

150, avenue de Stalingrad

93 245 - STAINS CEDEX – France

☎ : 33 (0)1 49 40 25 25      Fax : 33 (0)1 48 26 07 16

**[www.kremlin-rexson.com](http://www.kremlin-rexson.com)**



**The equipment is manufactured under the ATEX agreement and should not be modified. KREMLIN REXSON will not be held responsible for any failure to comply with that instruction.**

**Guards (air motor cover, coupling shields, connectors,...) have been designed for safe use of the equipment.**

**The manufacturer will not be held responsible for bodily injury or failure and / or property damage to property due to removal or partial removal of the guards.**



**CAUTION :**

**Before any intervention on the equipment, shut off the air supply and follow the general safety instructions. Open the drain or the gun to depressurize the gun. The ram must be in the low position.**

FAULTS	CAUSES	SOLUTIONS
Pump does not start or stops	Air supply Packings of fluid section are stuck Frosting (motor) Nozzle is clogged	Check air pressure Clean or replace Defrost and lubricate using oil. Clean it.
The pump cycles continuously (drain valve closed)	No starting up Lack of material Valve is blocked	Check feeding pressure Add material Clean or replace
The pump piston goes down faster than it goes up	Leakage from the suction valve	Clean the suction valve. Replace it if necessary.
The pump piston goes up faster than it goes down	Leakage from the exhaust valve	Clean the exhaust valve. Replace it if necessary.
The pump goes down rapidly half way, then resumes normal speed	Pump improperly drained Leakage from the suction valve	Open the drain valve until material starts coming out regularly. Then, close the drain valve. Check the suction valve. Replace it if necessary.
The pump operates but provides an irregular flow rate	Air in the chamber Bad tightness of the valves Leakage during the exhaust Muffler clogged up	Check the fittings Clean Check the motor piston seals; change them if necessary Clean or change the muffler
Motor piston locked	Defective sensor (s) Defective control distributor Defective power distributor	Adjust the sensor (s). Change it (them) if necessary. Check the operating of the control distributor. Change it if necessary. Check the operating of the power distributor. Change it if necessary.

<b>FAULTS</b>	<b>CAUSES</b>	<b>SOLUTIONS</b>
Important leakage during the exhaust	Distributor seals incorrectly mounted Defective power distributor	Check the seals; replace them if necessary Check the operating of the power distributor. Change it if necessary.
Leakage from the cupel seals	Cupel not tightened Fluid section seals incorrectly mounted Material / seal not compatible Seals damaged	Tight the cupel Check the seals. Change them if necessary Check the material / seal compatibility Change the seals
Cupel seals quickly damaged	Lack of lubrication Material / seal not compatible Seals damaged	Check cupel has lubricant. Clean it and fill the cupel if necessary. Check the material / seal compatibility Change the seals
The ram does not go up any more	Insufficient air supply Lever of the distributor in the middle position	Increase air pressure Check the connection Move the lever of the distributor upwards to make go up the unit
The ram does not down up any more	Insufficient air supply Lever of the distributor in the middle position	Increase air pressure Check the connection Move the lever of the distributor downwards to make down the unit
Ram goes up / goes down intermittently	Seals damaged	Change the seals
Air leakage from the piston rod	Seals damaged	Change the seals



# **EXTRUSION UNIT**

## ***OPERATING AND START-UP***

### **TRANSLATION OF THE ORIGINAL MANUAL**

***IMPORTANT : Before assembly and start-up, please read and clearly understand all the documents relating to the equipment (professional use only).***

THE PICTURES AND DRAWINGS ARE NOT CONTRACTUAL. WE RESERVE THE RIGHT TO MAKE CHANGES WITHOUT PRIOR NOTICE.

#### **KREMLIN - REXSON**

150, avenue de Stalingrad

93 245 - STAINS CEDEX – France

☎ : 33 (0)1 49 40 25 25      Fax : 33 (0)1 48 26 07 16

**[www.kremlin-rexson.com](http://www.kremlin-rexson.com)**

# 1. OPERATING PRINCIPLE

The pneumatic motors are designed to be coupled with the recommended KREMLIN-REXSON fluid section to get the required ratio and flow rate.

The pneumatic motors with rectilinear alternative motions operate thanks to the compressed air supply. The reversing system is carried out by means of :

- a distributor, model 4/2,
- two sensors,
- a distributor, model 5/2.

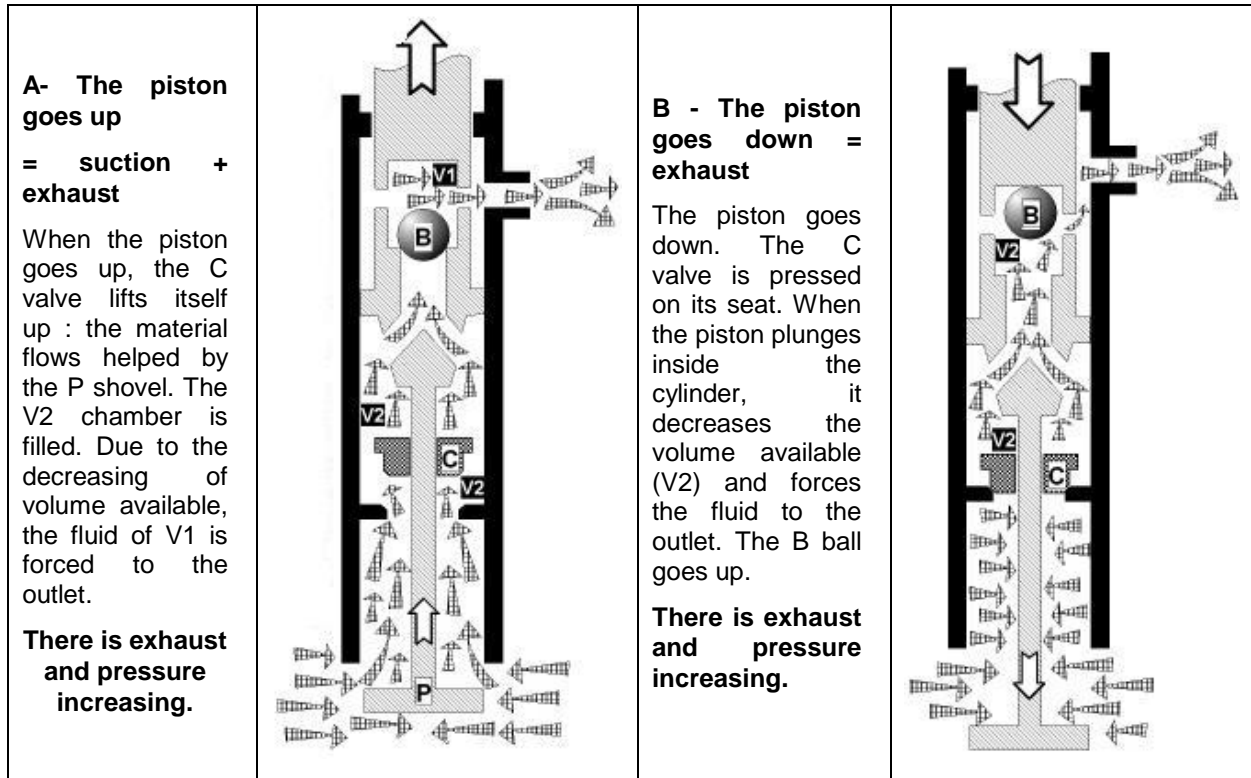

### WARNING!



The frictions due to the displacement of fluid inside the pumps and accessories, as well as the one created by the tightness seals, generate static electricity that may cause fire or explosion. This is why the pump must be grounded.

## 2. INSTALLATION

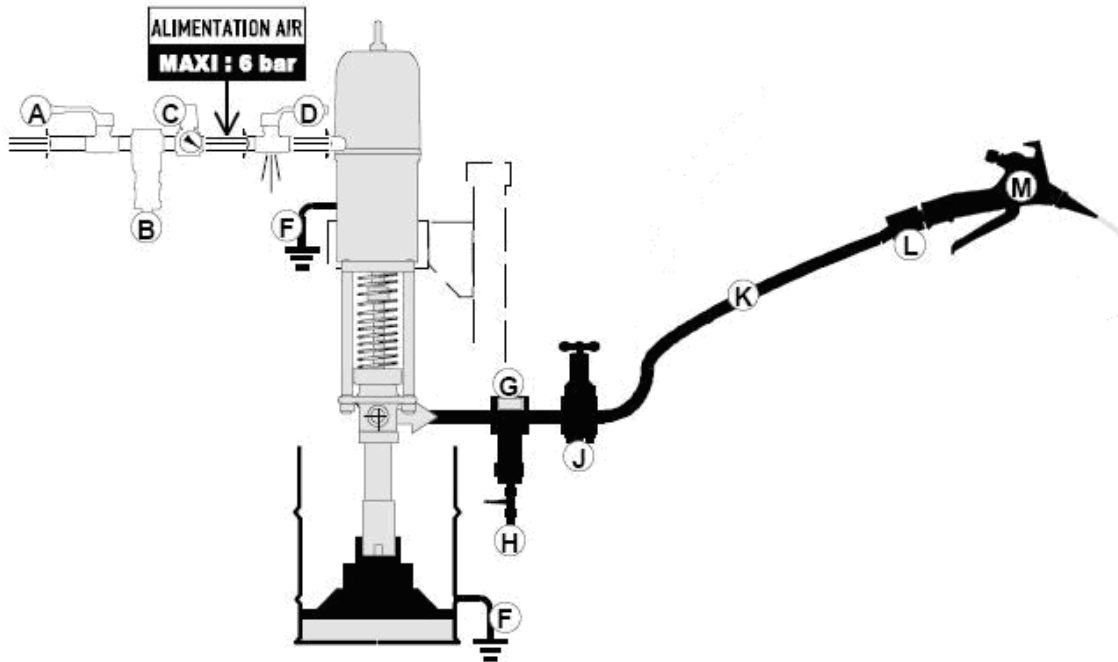

A	Air valve (main shut off valve)	G	Material filter
B	Filter or purifier	H	Fluid drain valve
C	Air regulator	J	Fluid regulator
D	Depressurize valve (air)	K	Hose (HP) with ground
E	Pump	L	Swivel fitting
F	Grounding	M	Spray gun

(For other installation, please contact KREMLIN REXSON).

### 3. USE

#### ■ ADJUSTMENT

The increase of the motor supply air pressure (via the air regulator) leads to an increase of the number of pump piston returns/mn (cycles) which leads to a flow rate increase and to an outlet pressure increase of the pumped material.

AIR CONSUMPTION OF THE MOTORS	
Pressure of the motors at 6 bar / 87 psi	
Version	daN
3000	920
5000	1700
7000	2940
9000	4520

**Version 3000**

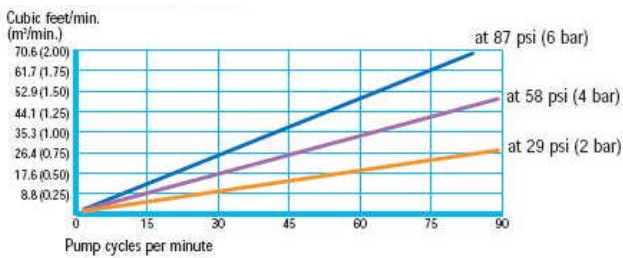

**Version 5000**

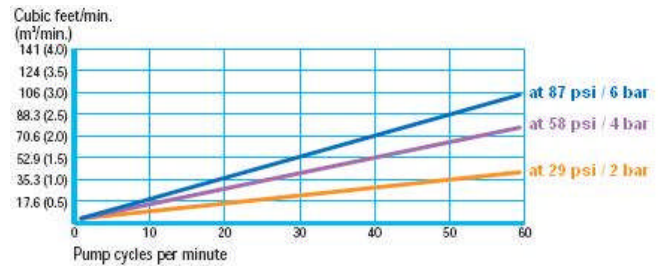

**Version 7000**

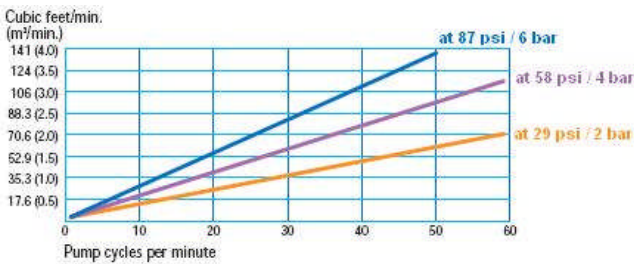

**Version 9000**

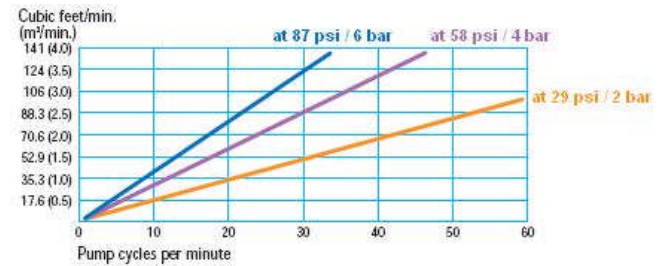

## 4. PNEUMATIC CABLING

Pneumatic diagram - Motor 3000

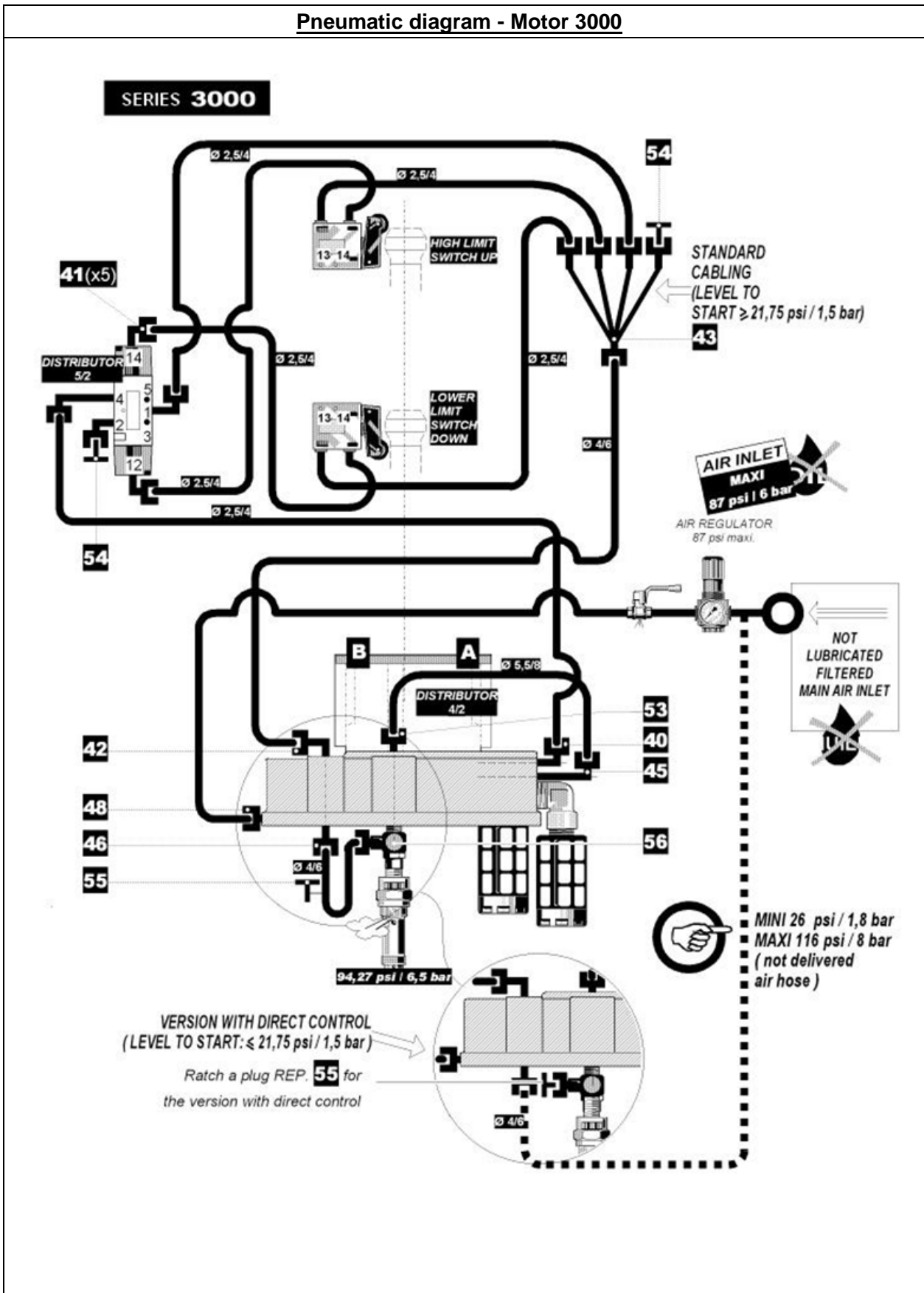

**Pneumatic diagram - Motors 5000 - 7000 - 9000**

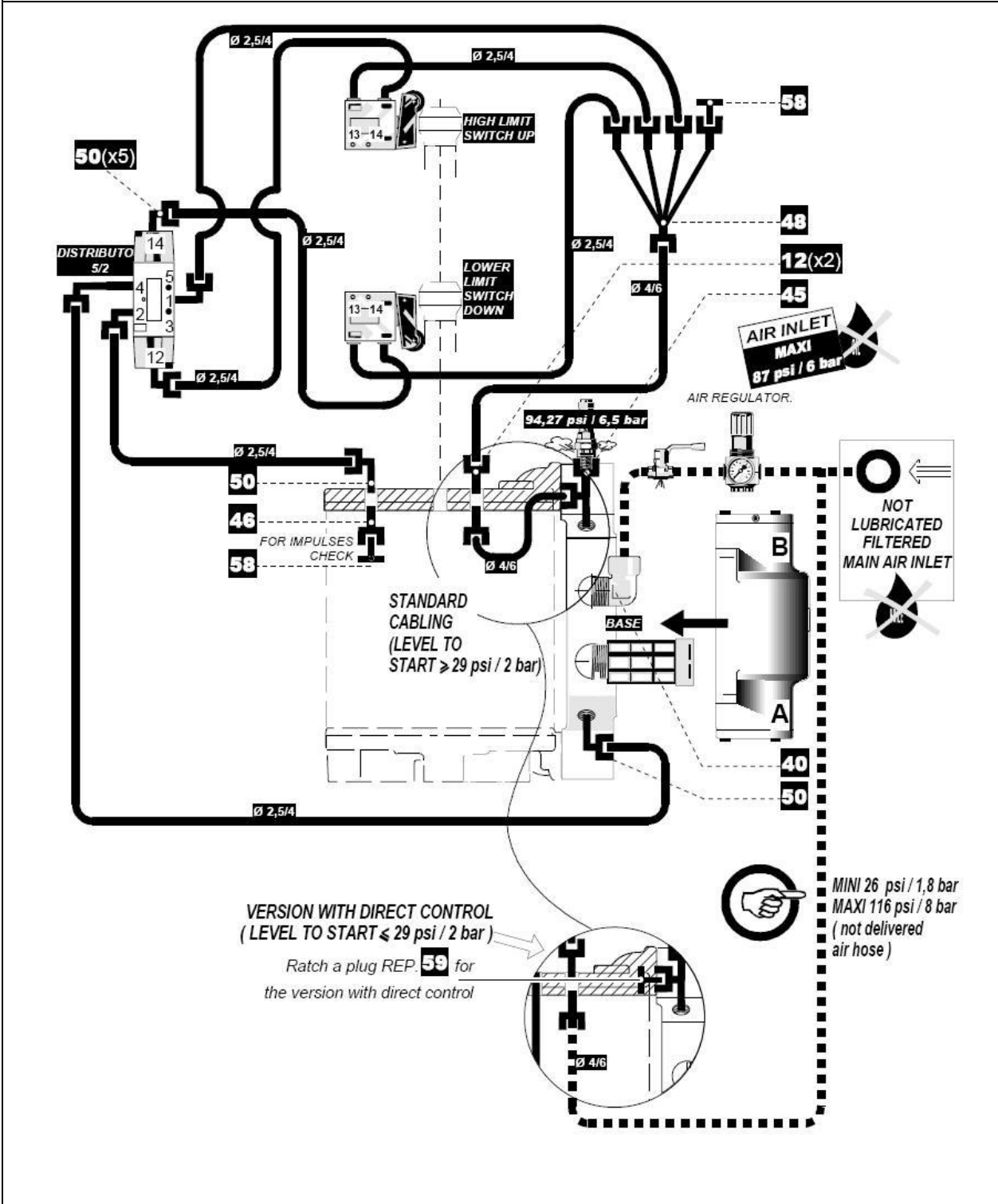



Type 3000

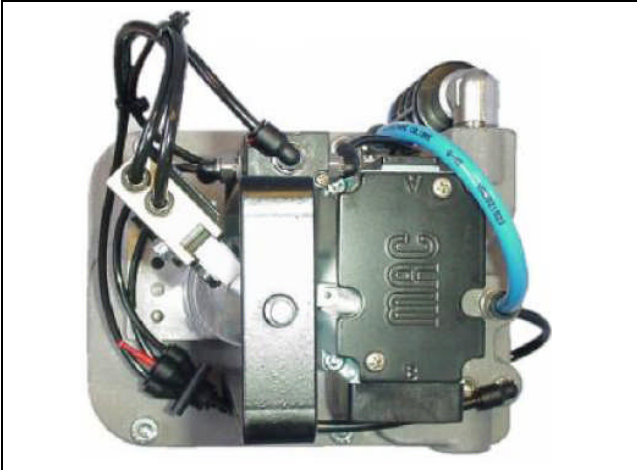

Type 5000- 7000 - 9000

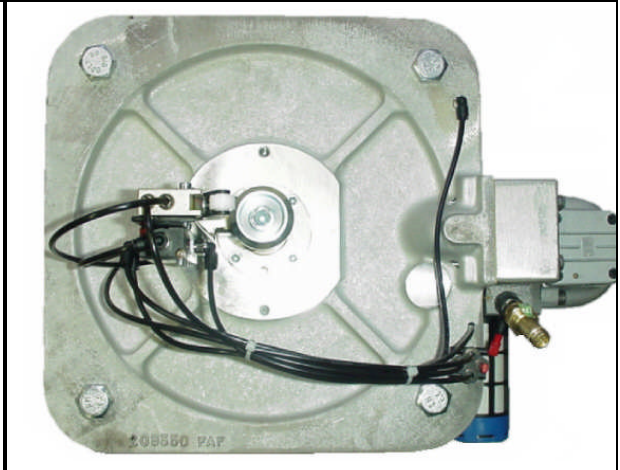

Standard cabling

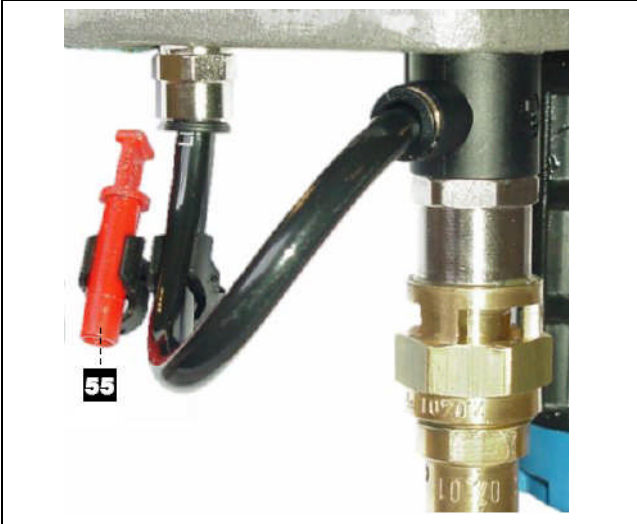

Direct control

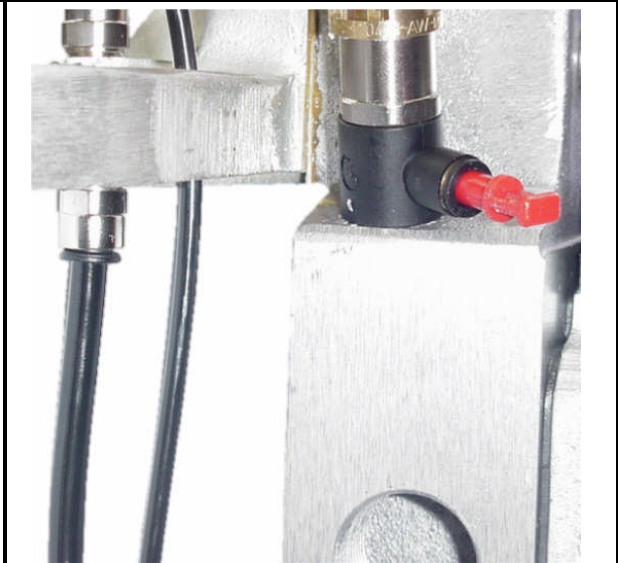
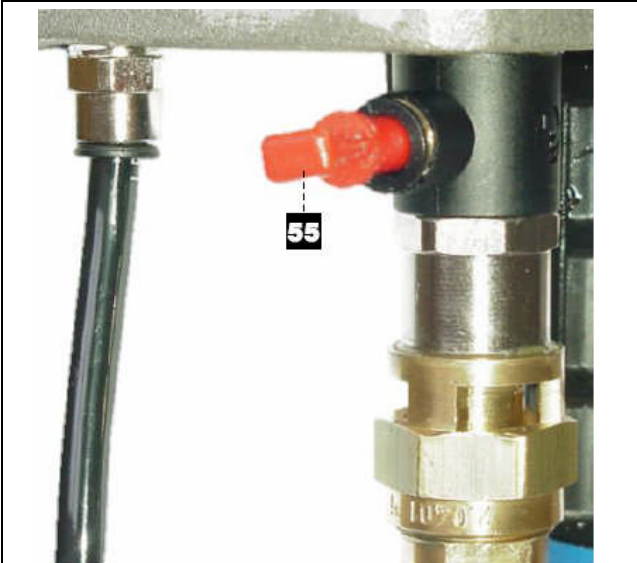

The motors mounted in our plant are cabled in **standard piloting**. The threshold of the motor starting is about 1.5 bar / 21.7 psi.

If the user wants to get a motor starting with a pressure of about 0.5 bar / 7.25 psi, the cabling can be modified in **direct piloting**.

## 5. START UP

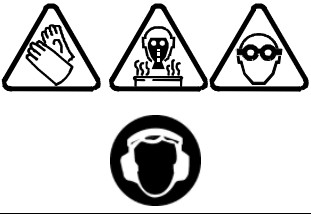
	<p>Protective clothing (gloves, protective masks, glasses, hearing protective earplug, protective clothing,...) should be worn to comply with the recommendations.</p> <p>The working area must be correctly ventilated.</p>
-----------------------------------------------------------------------------------	------------------------------------------------------------------------------------------------------------------------------------------------------------------------------------------------------------------------------

### ▪ BEFORE STARTING THE EQUIPMENT

***Guards (air motor cover, coupling shields, connectors,...) have been designed for safe use of the equipment.***

***The manufacturer will not be held responsible for bodily injury or failure and / or property damage to property due to removal or partial removal of the guards.***

### GROUNDING OF THE PUMP

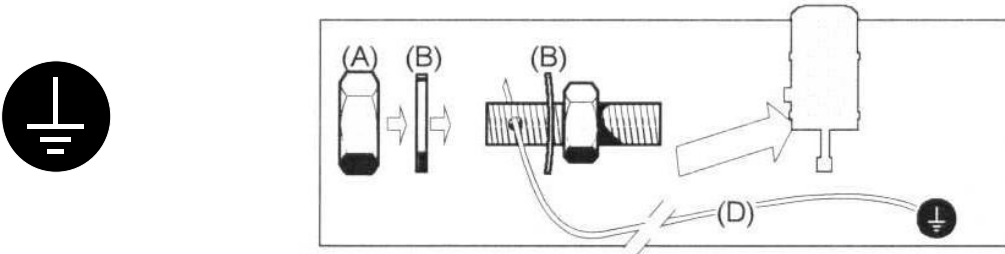

Unscrew the lock-nut (A), introduce between the washers (B) the end of a ground wire (D) (minimum section : 1,5 mm<sup>2</sup> in the hole of the terminal). Tighten the lock-nut. Connect the other end of the wire to a real "ground", according to the national rules.

A qualified electrician must check the ground continuity. If the continuity is not correct, check the terminal, the electric wire, the U bolt and the ground point. Never operate pump without revolving the trouble.

### CONNECTION OF THE COMPRESSED AIR SUPPLY

For a correct operating and a long duration life of the motor, supply air must be filtered and not lubricated (Cf § Troubleshooting guide).

- You must install a **pressure relief valve** after the air regulator and near to the inlet motor to follow the pressure relief instructions (refer to instruction manual - § Troubleshooting chart).
- The motor air supply hose should have an internal diameter of at least 19 mm / 0.75".
- The motors are tested prior to their sending. Nonetheless, before coupling the motor to the pump, you must operate the no load motor during a few minutes to a maximum pressure of 1 bar / 14.5 psi.

Then, comply with the instructions as follows :

- Couple the motor to the required fluid section,
- Connect the main air supply to the motor,
- Adjust the pressure by means of the air regulator.

## ▪ ADJUSTMENT

***Guards (air motor cover, coupling shields, connectors,...) have been designed for safe use of the equipment.***

***The manufacturer will not be held responsible for bodily injury or failure and / or property damage to property due to removal or partial removal of the guards.***

Before starting the equipment, half fill the cup with T lubricant.

Follow these instructions :

- The main air valve (A) is closed,
- Close the depressurize valve (D),
- Close the drain valve (H),
- Adjust the air regulator (C) sur 'O'.
- Régler le régulateur produit (J) on zero,
- Close the gun (M) (valve, gun, etc.),
- Open partially the drain valve (H), place a drum to get the drained material,
- Open the air valve (A),
- Open the depressurize air valve (D),
- Adjust the air regulator (C) to operate slowly the pump,
- Operate to get off air from the follower plate and the pump,
- Close the drain valve (H),
- Open the fluid regulator (J),
- Trigger the gun (M) (valve, etc.) and let it on the drum (grounded) to get off air from hoses, gun, valve,...
- Material must flow continuously (without air bubble),
- The pump must stop when the gun is closed (M) (valve, gun, etc.).

Then adjust :

- air pressure to the regulator (C) ,
- fluid pressure to the regulator (J),

Depending upon :

- material viscosity,
- gun nozzle diameter (M),
- material hoses' length and diameter (K),
- work.

**Nota : Before starting the work, check that the working range is correct.** The cup nut must be slightly tightened. A too important tightening would damage the cup seals. A wrench is supplied to allow a correct tightening.

### **Tightening of the wetting cup**

- Fill the cup with T lubricant,
- Start the pump, then tighten the cup after 10 minutes, then one hour and then one day of operating,
- If you notice a leakage, the cup must be tightened.

### **Tightening instructions :**

- Depressurize the motor (refer to pressure relief instructions),
- Depressurize the fluid circuit (refer to pressure relief instructions),
- Tighten the cup, clean it and fill it with T lubricant,
- Close the pump drain circuits,
- Open the motor air valve.

## ▪ START UP

***Guards (air motor cover, coupling shields, connectors,...) have been designed for safe use of the equipment.***

***The manufacturer will not be held responsible for bodily injury or failure and / or property damage to property due to removal or partial removal of the guards.***

The pumps are tested in our workshop with lubricant.

Before starting up, you must flush the pump with the appropriate solvent.

## 6. SHUTDOWN AT THE END OF THE WORK

Unscrew the air regulator (s).

Leave the pump full of material

If the pump is equipped with a follower plate, the follower must be in contact with the fluid to behave as a cover and prevent from the material drying.

When stopping the pump for a long time, after flushing it, leave it filled with solvent.

Depressurize the system.

### ▪ SHORT SHUTDOWN

Flush the installation with the appropriate solvent to prevent from material drying inside the pump, hoses or accessories. The solvent must flow in a closed circuit until you get a sufficient flushing.

We advice you to stop the pump in 'low reversing' to prevent from material drying on the piston rod. Position.

- 1 - Decrease air pressure regulator (D) until you get 0 bar / 0 psi on the gauge (E).
- 2 - Trigger the gun to depressurize the system.
- 3 - Unscrew the gun air regulator (F) or disconnect the gun air inlet.
- 4 - Remove the gun aircap and the nozzle (only when using an AIRMIX ® gun) and soak them into solvent.

### ▪ LONG SHUTDOWN

After flushing the installation, to prevent from corrosion, fill the pump with oil solvent to prevent air bubbles and neutralize the residual material.

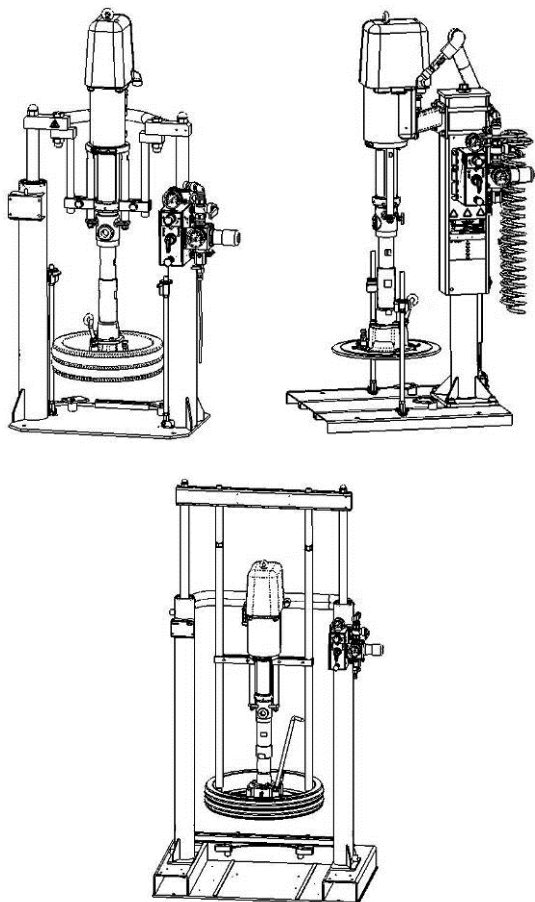

## **EXTRUSION UNITS**

### **THOR**

**60.60                      32.207**

**34.106                     53.216**

**63.106                     82.216**

### **TECHNICAL FEATURES**

### **TRANSLATION FROM THE ORIGINAL MANUAL**

***IMPORTANT : Before assembly and start-up, please read and clearly understand all the documents relating to the equipment (professional use only).***

THE PICTURES AND DRAWINGS ARE NOT CONTRACTUAL. WE RESERVE THE RIGHT TO MAKE CHANGES WITHOUT PRIOR NOTICE.

#### **KREMLIN - REXSON**

150, avenue de Stalingrad

93 245 - STAINS CEDEX - France

**☎ : 33 (0)1 49 40 25 25      Fax : 33 (0)1 48 26 07 16**

**[www.kremlin-rexson.com](http://www.kremlin-rexson.com)**

## 1. DESCRIPTION

The extrusion units are designed for pumping viscous materials.

They can process a wide range of materials including grease, adhesives, sealants and other similar materials. You can process products up to 1 million centipoises.

These extrusion units consist of :

- An extrusion pump,
- A single-post or twin-post ram,
- A follower plate with flat single seal or double O-Ring seal.

The modular conception allows you to install options (filters, regulators,...).

## 2. TECHNICAL FEATURES

### ▪ EXTRUSION UNIT - THOR 60.60

Motor type .....	3000
Pump body type .....	60 cc
Pressure ratio .....	60/1
Weight (bare pump).....	19 kg / 41.8 lb

#### Wetted parts :

Carbon steel

#### Tightness packings :

PTFE / PE

Motor stroke	120 mm	4.7"
Fluid volume per cycle	60 cm <sup>3</sup>	2.03 oz
Free flow rate (at 60 cycles)	3,6 l/min	0.95 US gal
Flow rate (at 30 cycles)	1,8 l	0.47 US gal
Maximum air inlet pressure	6 bar	87 psi
Maximum fluid pressure	360 bar	5221 psi
Weighted sound pressure (LAeq)	62.5 dBa	62.5 dBa
Maximum fluid temperature	60°C	140° F

*Nota : Data given for information only*

#### Test conditions - Noise level :

- Test duration : 30 s,
- Motor air pressure : 6 bar / 87 psi,
- Material used : water,
- Regulation valve,
- Flow rate : Pump adjusted at 20 cycles / minute.

▪ **EXTRUSION UNIT - THOR 34.106**

Motor type..... 3000  
 Pump body type ..... 106 cc  
 Pressure ratio ..... 34/1  
 Weight (bare pump)..... 18 kg / 39.6 lb

**Wetted parts :**

Carbon steel

**Tightness packings :**

PTFE / PE

Motor stroke	120 mm	4.7"
Fluid volume per cycle	106 cm <sup>3</sup>	3.58 oz
Free flow rate (at 60 cycles)	6,3 l/min	1.66 US gal
Flow rate (at 30 cycles)	3,18 l	0.84 US gal
Maximum air inlet pressure	6 bar	87 psi
Maximum fluid pressure	204 bar	2958.6 psi
Weighted sound pressure (LAeq)	62,5 dBa	62.5 dBa
Maximum fluid temperature	60°C	140° F

*Nota : Data given for information only*

**Test conditions - Noise level :**

- Test duration : 30 s,
- Motor air pressure : 6 bar / 87 psi,
- Material used : water,
- Regulation valve,
- Flow rate : Pump adjusted at 20 cycles / minute.

▪ **EXTRUSION UNIT - THOR 63.106**

Motor type..... 5000  
 Pump body type ..... 106 cc  
 Pressure ratio ..... 63/1  
 Weight (bare pump)..... 30 kg

**Wetted parts :**

Carbon steel

**Tightness packings :**

PTFE / PE

Motor stroke	120 mm	4.7"
Fluid volume per cycle	106 cm <sup>3</sup>	3.58 oz
Free flow rate (at 60 cycles)	6,3 l/min	1.66 US gal
Flow rate (at 30 cycles)	3,18 l	0.84 US gal
Maximum air inlet pressure	6 bar	87 psi
Maximum fluid pressure	378 bar	5482 psi
Weighted sound pressure (LAeq)	67,2 dBa	67.2 dBa
Maximum fluid temperature	60°C	140° F

*Nota : Data given for information only*

**Test conditions - Noise level :**

- Test duration : 30 s,
- Motor air pressure : 6 bar / 87 psi,
- Material used : water,
- Regulation valve,
- Flow rate : Pump adjusted at 20 cycles / minute.

▪ **EXTRUSION UNIT - THOR 32.207**

Motor type.....5000  
 Pump body type .....207 cc  
 Pressure ratio .....32/1  
 Weight (bare pump).....31.5 kg / 69.4 Lb

**Wetted parts :**

Carbon steel

**Tightness packings :**

PTFE / PE

Motor stroke	120 mm	4.7"
Fluid volume per cycle	207 cm <sup>3</sup>	7 oz
Free flow rate (at 60 cycles)	12,4 l/min	3.27 US gal
Flow rate (at 30 cycles)	6,21 l	1.64 US gal
Maximum air inlet pressure	6 bar	87 psi
Maximum fluid pressure	192 bar	2784.5 psi
Weighted sound pressure (LAeq)	67,2 dBa	67.2 dBa
Maximum fluid temperature	60°C	140° F

*Nota : Data given for information only*

**Test conditions - Noise level :**

- Test duration : 30 s,
- Motor air pressure : 6 bar / 87 psi,
- Material used : water,
- Regulation valve,
- Flow rate: Pump adjusted at 20 cycles / minute.

▪ **EXTRUSION UNIT - THOR 53.216**

Motor type.....7000  
 Pump body type .....216 cc  
 Pressure ratio .....53/1  
 Weight (bare pump).....51 kg / 112 lb

**Wetted parts :**

Carbon steel

**Tightness packings :**

PTFE / PE

Motor stroke	120 mm	4.7"
Fluid volume per cycle	216 cm <sup>3</sup>	7.3 oz
Free flow rate (at 60 cycles)	12,9 l/min	3.41 US gal
Flow rate (at 30 cycles)	6,48 l	1.71 US gal
Maximum air inlet pressure	6 bar	87 psi
Maximum fluid pressure	318 bar	4612 psi
Weighted sound pressure (LAeq)	72,9 dBa	72.9 dBa
Maximum fluid temperature	60°C	140° F

*Nota : Data given for information only*

**Test conditions - Noise level :**

- Test duration : 30 s,
- Motor air pressure : 6 bar / 87 psi,
- Material used : water,
- Regulation valve,
- Flow rate: Pump adjusted at 20 cycles / minute.



▪ **EXTRUSION UNIT - THOR 82.216**

Motor type.....9000  
 Pump body type ..... 216 cc  
 Pressure ratio ..... 82/1  
 Weight (bare pump).....62 kg / 136.6 lb

**Wetted parts :**

Carbon steel

**Tightness packings :**

PTFE / PE

Motor stroke	120 mm	4.7"
Fluid volume per cycle	216 cm <sup>3</sup>	7.3 oz
Free flow rate (at 60 cycles)	12,9 l/min	3.41 US gal
Flow rate (at 30 cycles)	6,48 l	1.71 US gal
Maximum air inlet pressure	6 bar	87 psi
Maximum fluid pressure	492 bar	7135.5 psi
Weighted sound pressure (LAeq)	74,6 dBA	74.6 dBA
Maximum fluid temperature	60°C	140° F

*Nota : Data given for information only*

**Test conditions - Noise level :**

- Test duration : 30 s,
- Motor air pressure : 6 bar / 87 psi,
- Material used : water,
- Regulation valve,
- Flow rate: Pump adjusted at 20 cycles / minute.

▪ **FITTINGS**

<b>Air</b>	Inlet	F 3/4" G
<b>Material</b>	Inlet	Ø 80 mm
	Outlet	M 3/4" G

▪ **DIMENSIONS**

- Extrusion unit - THOR 60.60

Mini single

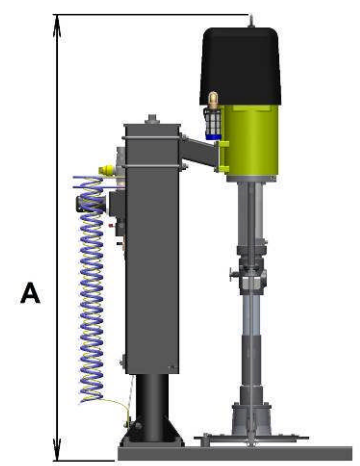

**A**

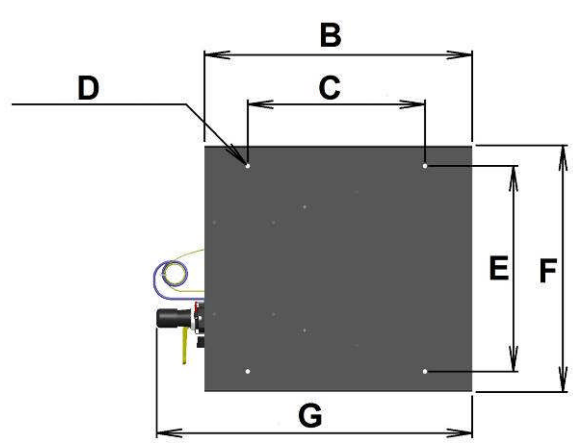

**B**  
**C**  
**D**  
**E**  
**F**  
**G**

Ind.	mm		Ind.	mm	Ind.	mm
<b>A</b>	High position	1721	<b>B</b>	650	<b>C</b>	430
	Low position	1246	<b>D</b>	Ø 10.7	<b>E</b>	500
	Stroke	475	<b>F</b>	600	<b>G</b>	766

### Mini twin

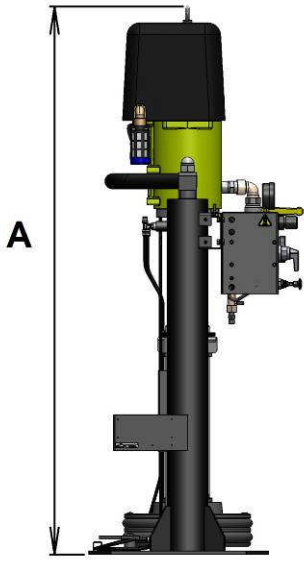
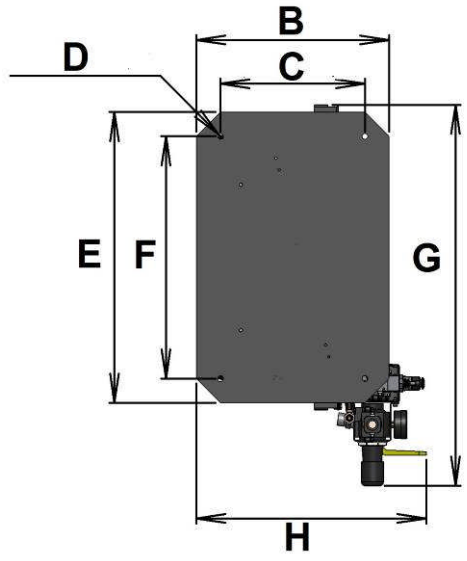
																																	
						<table border="1"> <thead> <tr> <th>Ind.</th> <th colspan="2">mm</th> </tr> </thead> <tbody> <tr> <td rowspan="3"><b>A</b></td> <td>High position</td> <td>2003</td> </tr> <tr> <td>Low position</td> <td>1215</td> </tr> <tr> <td>Stroke</td> <td>788</td> </tr> </tbody> </table>		Ind.	mm		<b>A</b>	High position	2003	Low position	1215	Stroke	788	<table border="1"> <thead> <tr> <th>Ind.</th> <th>mm</th> <th>Ind.</th> <th>mm</th> </tr> </thead> <tbody> <tr> <td><b>B</b></td> <td>400</td> <td><b>C</b></td> <td>300</td> </tr> <tr> <td><b>D</b></td> <td>Ø 12</td> <td><b>E</b></td> <td>600</td> </tr> <tr> <td><b>F</b></td> <td>500</td> <td><b>G</b></td> <td>786</td> </tr> <tr> <td><b>H</b></td> <td>478</td> <td></td> <td></td> </tr> </tbody> </table>		Ind.	mm	Ind.	mm	<b>B</b>	400	<b>C</b>	300	<b>D</b>	Ø 12	<b>E</b>	600	<b>F</b>	500
Ind.	mm																																
<b>A</b>	High position	2003																															
	Low position	1215																															
	Stroke	788																															
Ind.	mm	Ind.	mm																														
<b>B</b>	400	<b>C</b>	300																														
<b>D</b>	Ø 12	<b>E</b>	600																														
<b>F</b>	500	<b>G</b>	786																														
<b>H</b>	478																																

### Twin

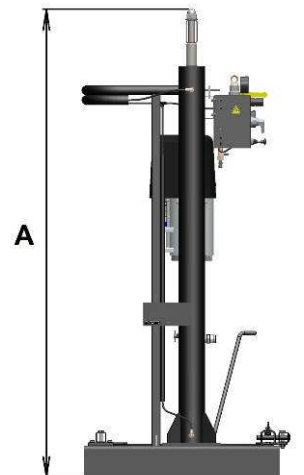
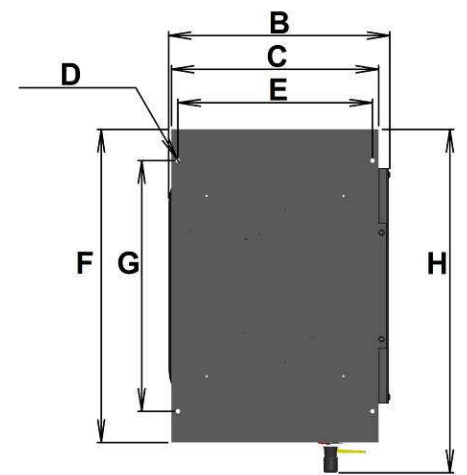
																																	
						<table border="1"> <thead> <tr> <th>Ind.</th> <th colspan="2">mm</th> </tr> </thead> <tbody> <tr> <td rowspan="3"><b>A</b></td> <td>High position</td> <td>2657</td> </tr> <tr> <td>Low position</td> <td>1607</td> </tr> <tr> <td>Stroke</td> <td>1050</td> </tr> </tbody> </table>		Ind.	mm		<b>A</b>	High position	2657	Low position	1607	Stroke	1050	<table border="1"> <thead> <tr> <th>Ind.</th> <th>mm</th> <th>Ind.</th> <th>mm</th> </tr> </thead> <tbody> <tr> <td><b>B</b></td> <td>711</td> <td><b>C</b></td> <td>666</td> </tr> <tr> <td><b>D</b></td> <td>Ø 14</td> <td><b>E</b></td> <td>625</td> </tr> <tr> <td><b>F</b></td> <td>1000</td> <td><b>G</b></td> <td>800</td> </tr> <tr> <td><b>H</b></td> <td>1096</td> <td></td> <td></td> </tr> </tbody> </table>		Ind.	mm	Ind.	mm	<b>B</b>	711	<b>C</b>	666	<b>D</b>	Ø 14	<b>E</b>	625	<b>F</b>	1000
Ind.	mm																																
<b>A</b>	High position	2657																															
	Low position	1607																															
	Stroke	1050																															
Ind.	mm	Ind.	mm																														
<b>B</b>	711	<b>C</b>	666																														
<b>D</b>	Ø 14	<b>E</b>	625																														
<b>F</b>	1000	<b>G</b>	800																														
<b>H</b>	1096																																

- Extrusion unit - THOR 34.106

### Mini twin

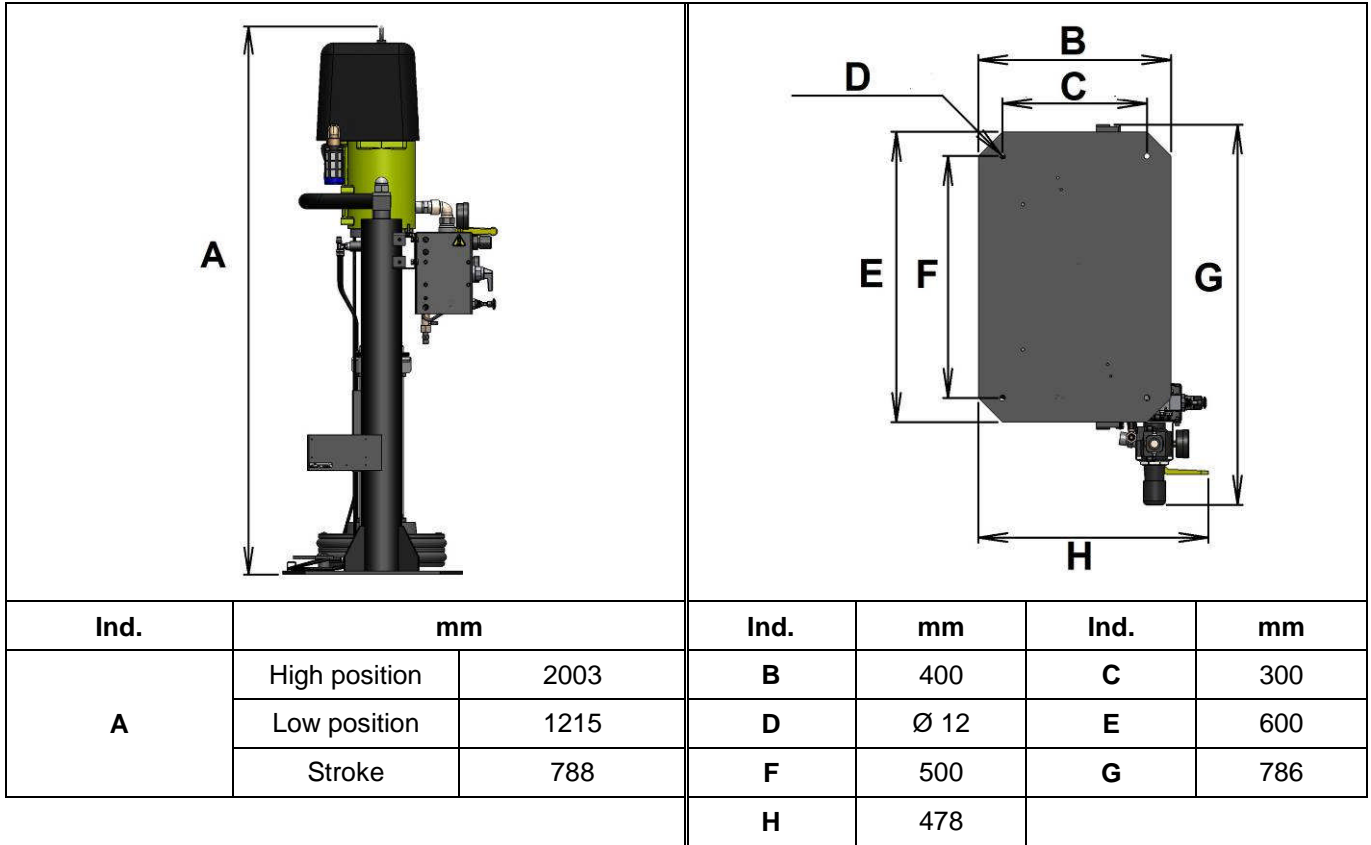

### Twin

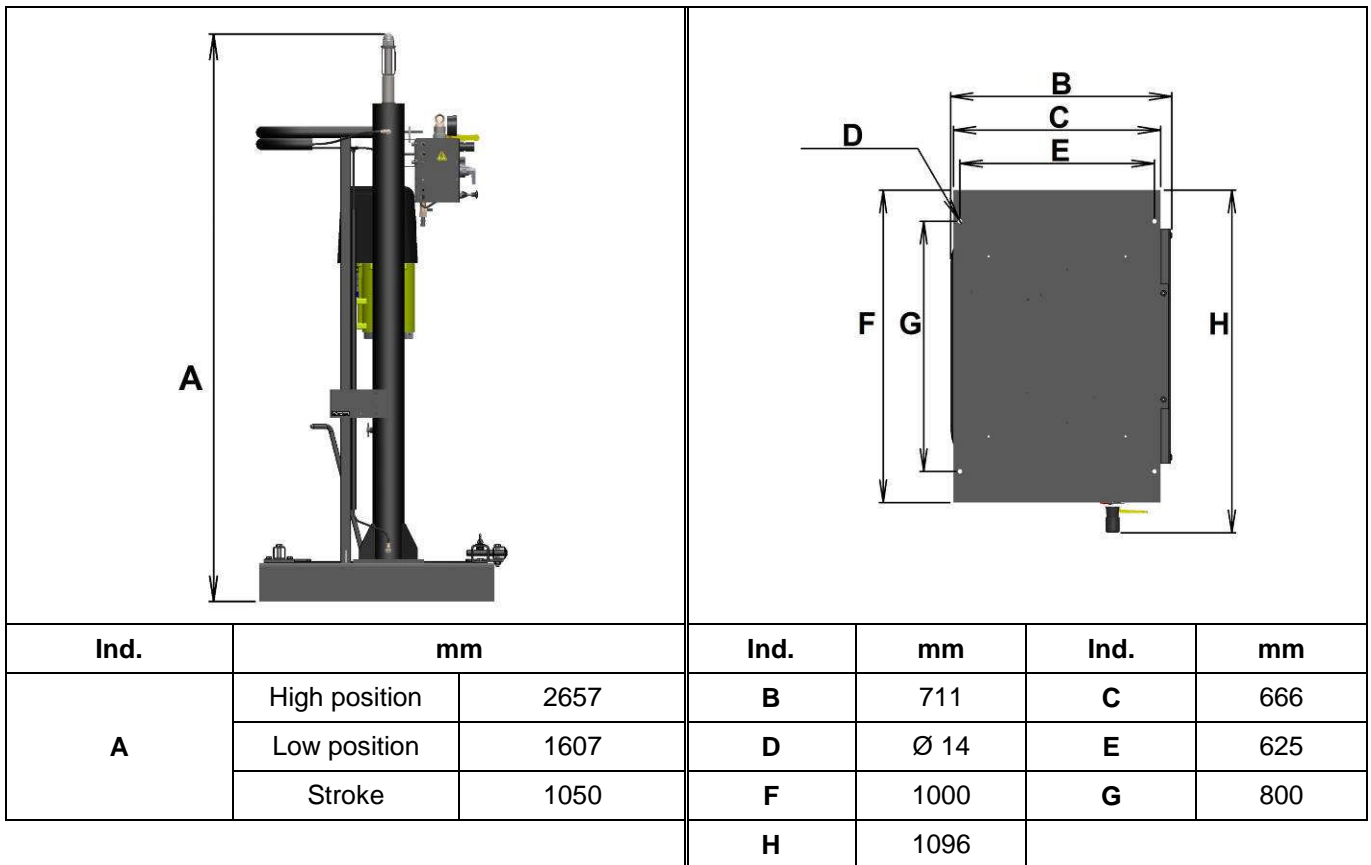

- Extrusion unit - THOR 63.106

**Mini twin**

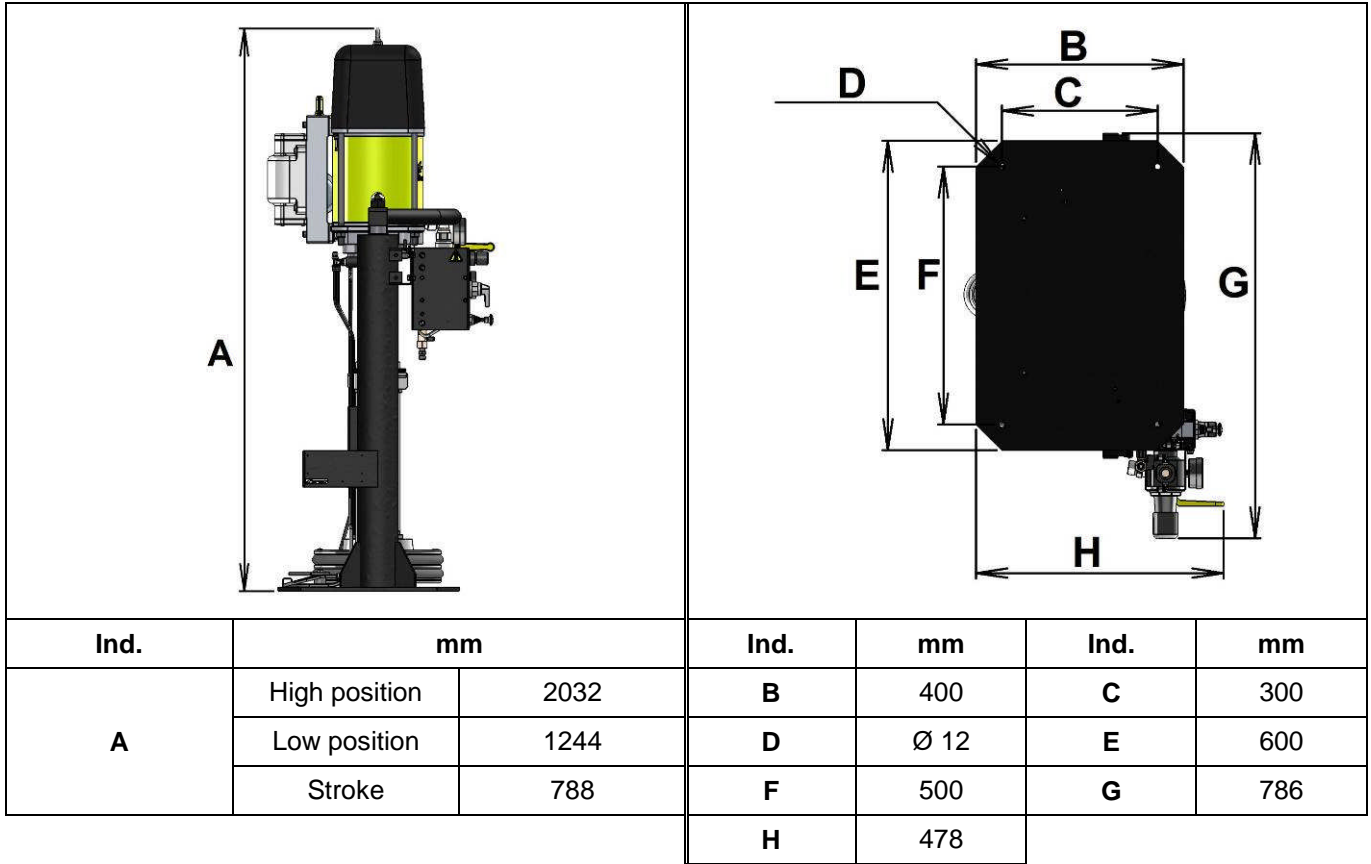

**Twin**

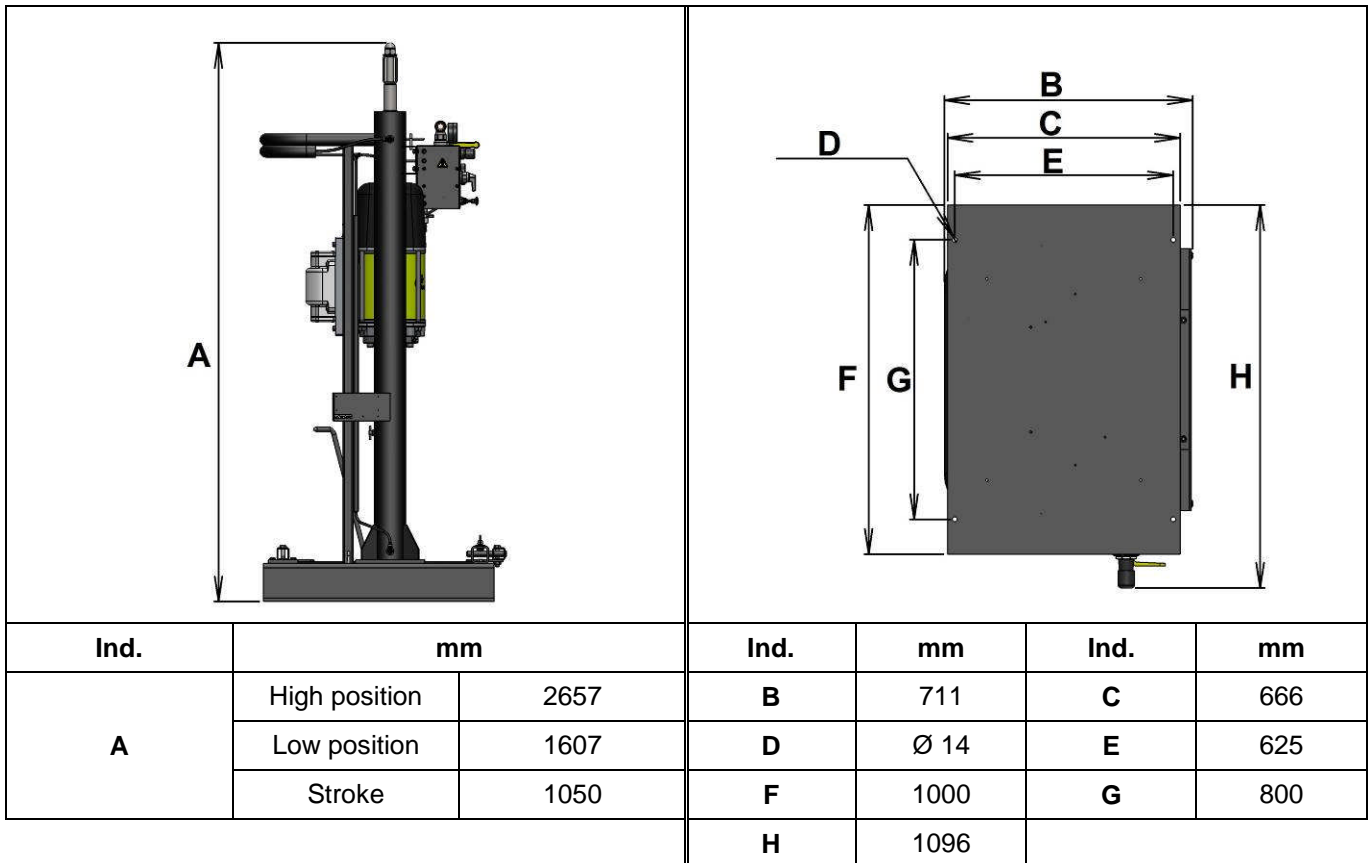

- Extrusion unit - THOR 32.207

### Mini twin

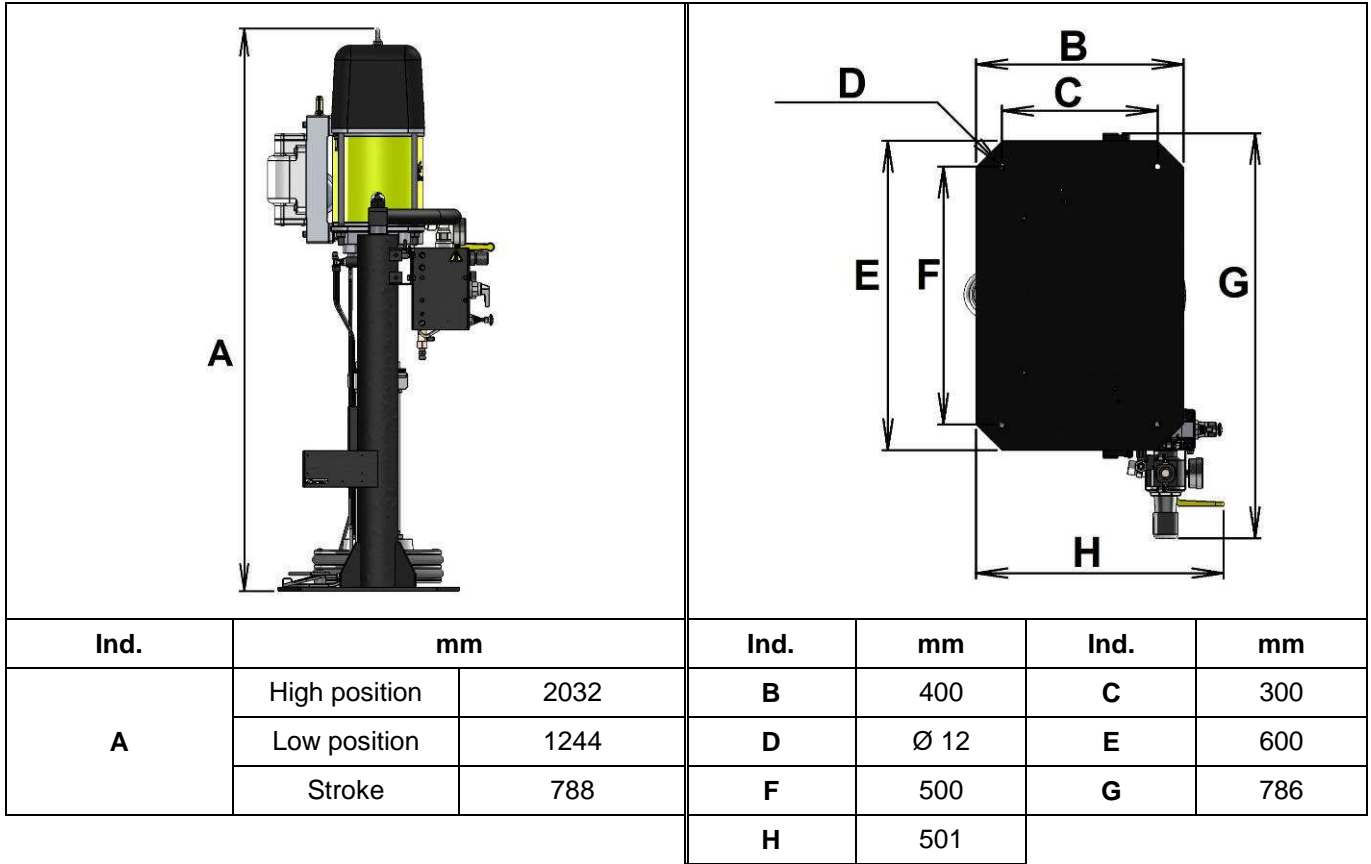

### Twin

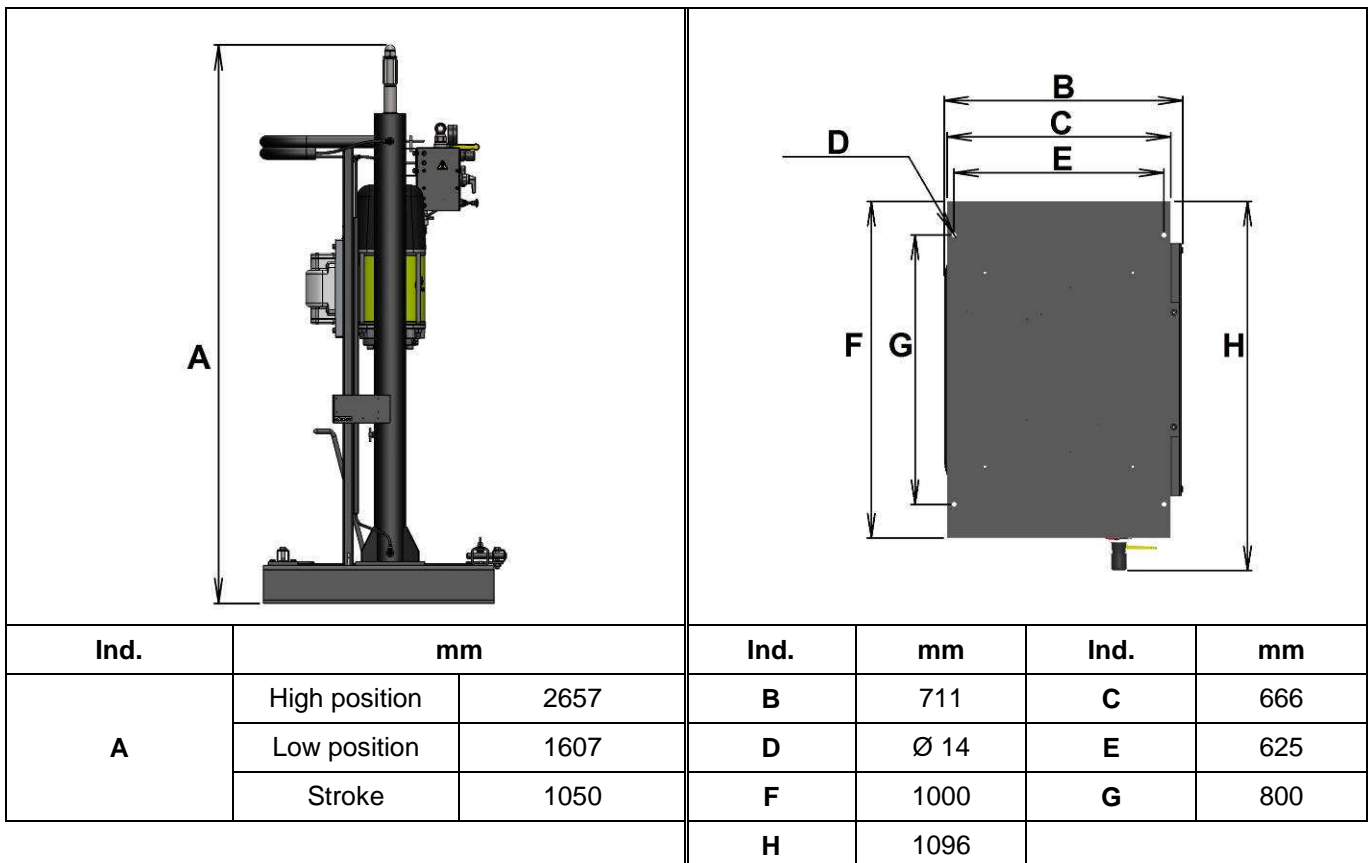

- Extrusion unit - THOR 53.216

### Mini twin

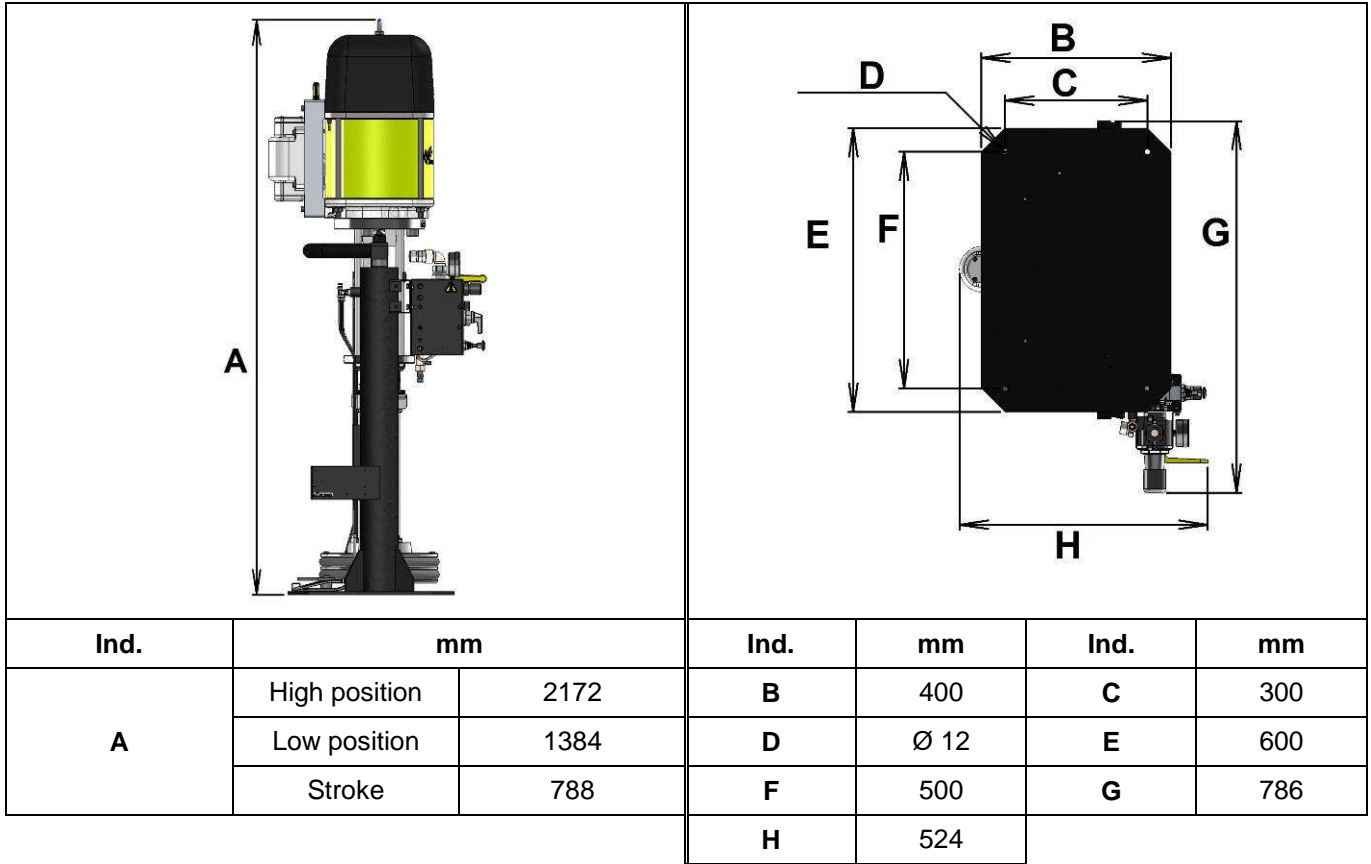

### Twin

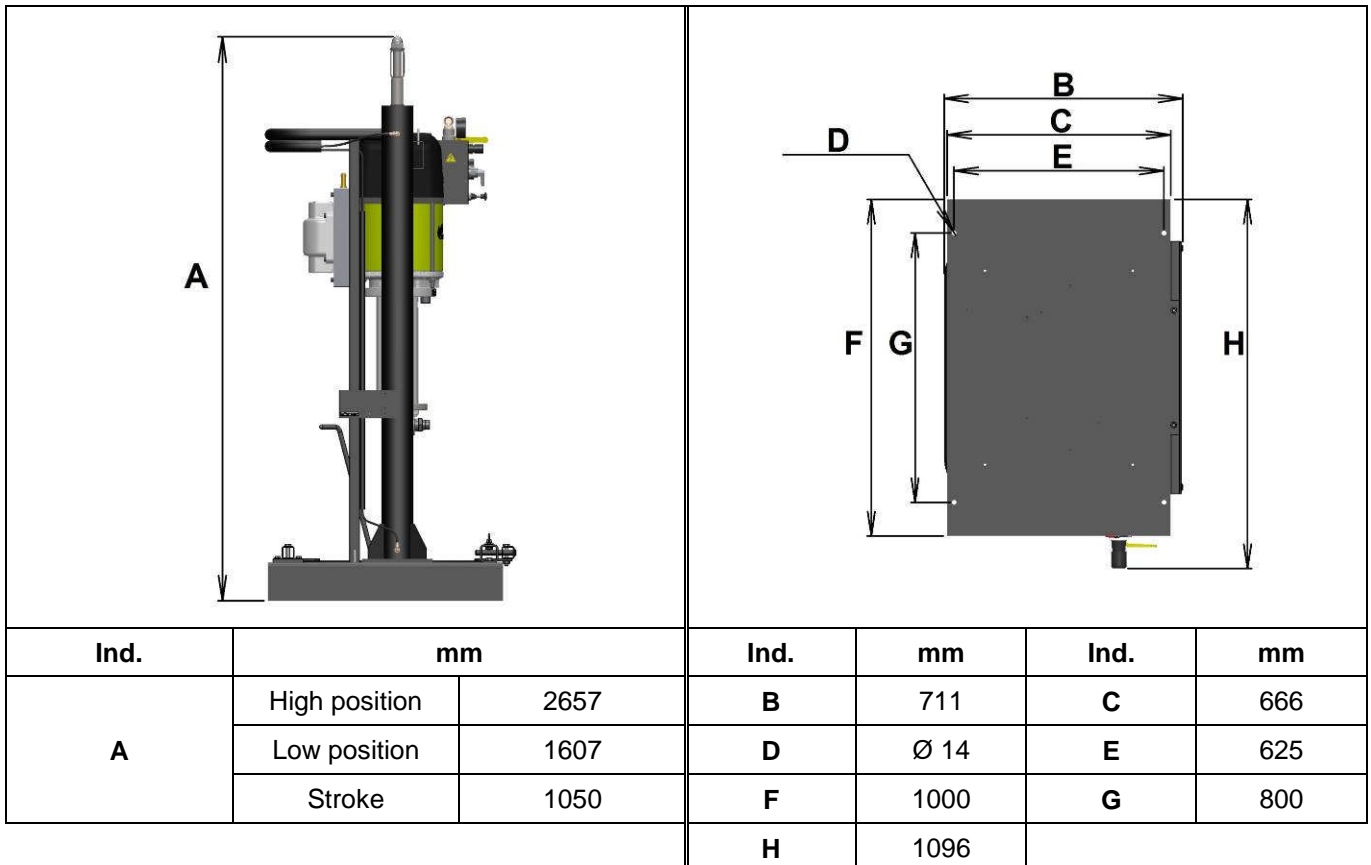

- Extrusion unit - THOR 82.216

**Mini twin**

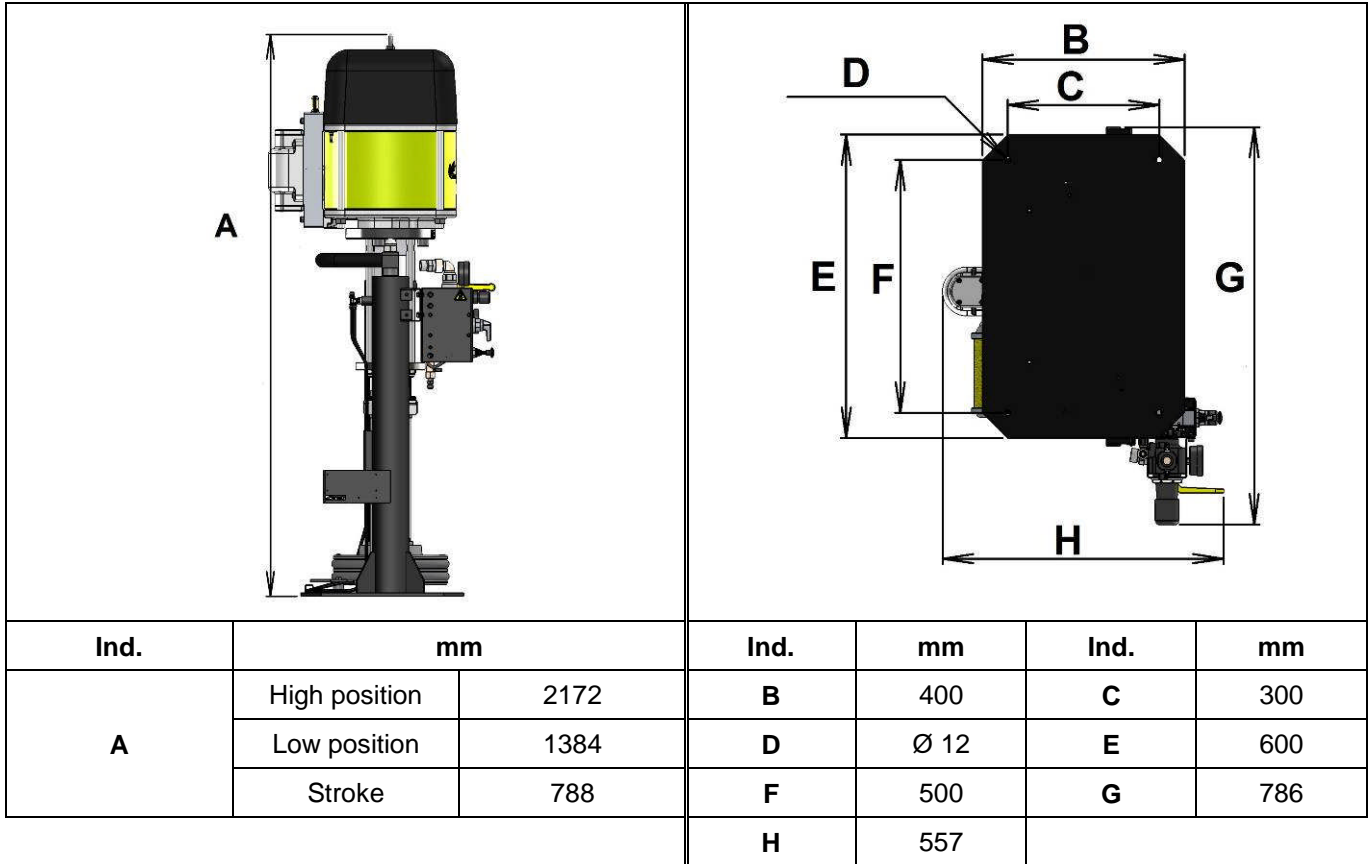

**Twin**

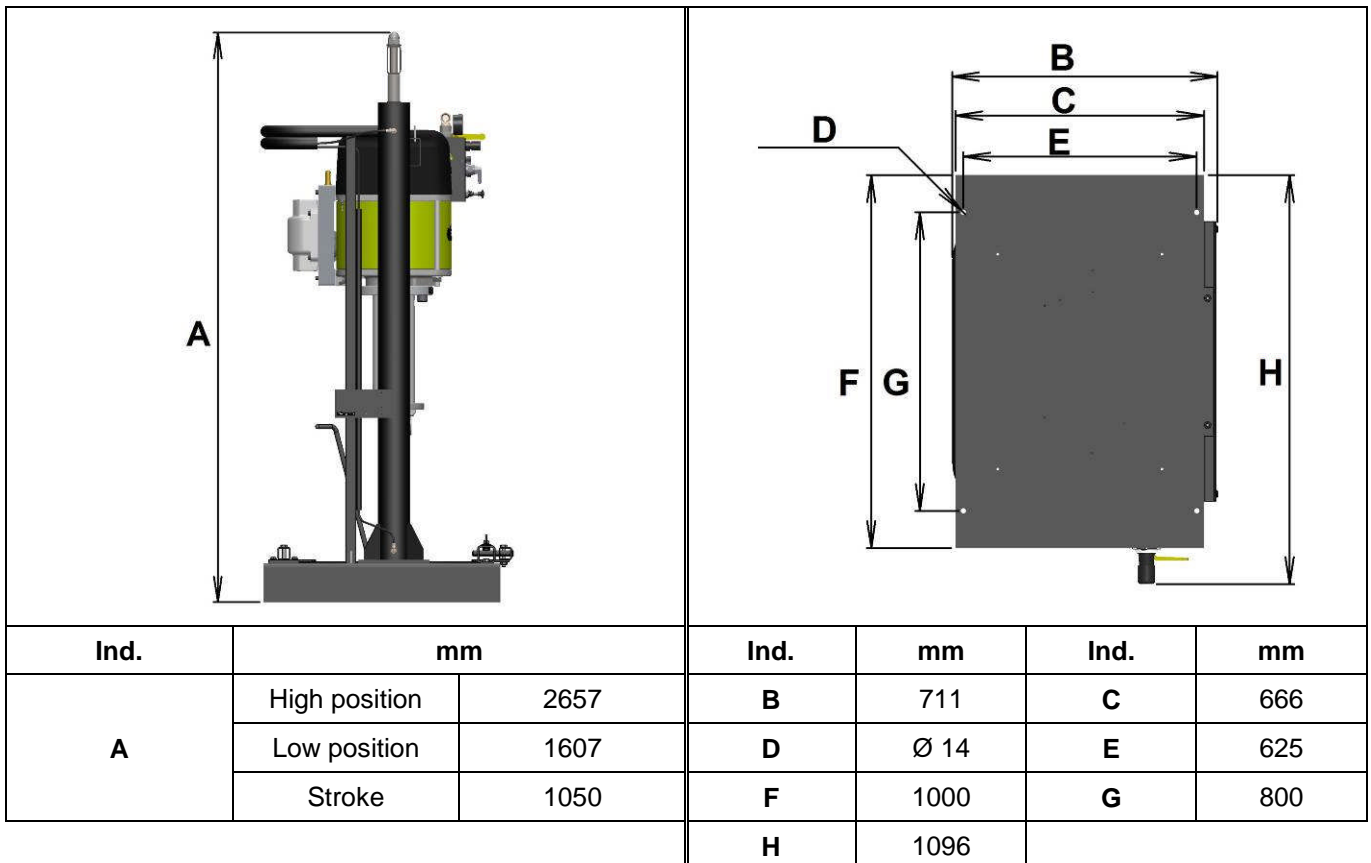

▪ DESCRIPTION OF THE LABEL MARKING

• LABEL MARKING OF THE PUMP

Marking according to the ATEX and Machines directives

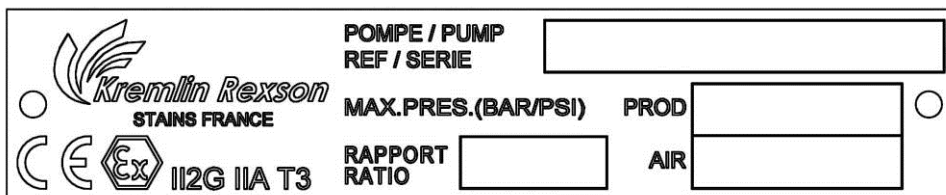

<b>KREMLIN REXSON</b>	Manufacturer brand
<b>CE</b>	European Conformity
<b>II 2 G</b>	<b>II</b> : group II <b>2</b> : class 2 Surface equipment meant to an area in which there is an explosive atmosphere with an excessive mixture of air, gases and vapours, which can occasionally build up during normal operation. <b>G</b> : gas
<b>IIA T3</b>	<b>IIA</b> : Gas group for the equipment category <b>T3</b> : Maximum surface temperature : 200°C / 392°F
<b>POMPE / PUMP</b>	Pump version
<b>REF.</b>	Pump part number
<b>SERIE</b>	Number given by KREMLIN REXSON. The 2 first numbers indicate the manufacturing year.
<b>MAX. PRES. (BAR/PSI)</b>	
<b>PROD</b>	Maximum material pressure
<b>AIR</b>	Maximum air pressure
<b>RAPPORT / RATIO</b>	Pump pressure ratio

• LABEL MARKING OF THE RAM

Marking according to the ATEX and Machines directives



<b>KREMLIN REXSON</b>	Manufacturer brand
<b>CE</b>	European Conformity
<b>II 2 G c</b>	<b>II</b> : group II <b>2</b> : class 2 Surface equipment meant to an area in which there is an explosive atmosphere with an excessive mixture of air, gases and vapours, which can occasionally build up during normal operation. <b>G</b> : gas <b>c</b> : Protection by constructional safety
<b>REF.</b>	Unit part number
<b>SERIE</b>	Number given by KREMLIN REXSON. The 2 first numbers indicate the manufacturing year.
<b>MAX. PRES. (BAR/PSI)</b>	Maximum pressure



- LABEL MARKING OF THE FOLLOWER PLATE



<b>KREMLIN REXSON</b>	Manufacturer brand
<b>REF.</b>	Follower plate part number
<b>SERIE</b>	Number given by KREMLIN REXSON. The 2 first numbers indicate the manufacturing year.