

# SAMES KREMLIN



**Airspray** spraying  
& equipment



## Catalog V5.1

"Manufacturer since 1925, bringing you the very best of the Finishing applications"

**Apply your Skills**

[www.sames-kremlin.com](http://www.sames-kremlin.com)



## Editor's note

 To help you increase your competitiveness, SAMES KREMLIN dedicates itself daily to excellence in terms of innovation and reliability.

We are constantly improving our performance, as well as, quality to meet your specific needs.

We also help you define the equipment allowing your installation to comply with V.O.C directives and industry standards.

We enable you to benefit from reliable technologies while ensuring you a swift return on investment.

In this catalog, you will find the equipment that will enable you to reach the paint application results you are targeting and the finish quality you desire.

Our Mission is to provide you with the best equipment to meet your needs and requirements.

The entire team at SAMES KREMLIN is at your disposal to answer your questions.

Enjoy your reading.



## Table of contents

## PRODUCTS RANGE

<b>MANUAL SPRAY GUNS</b>	<b>14</b>
M22 G HTi	14
M22 G HPA	16
M22 G BasiK HPA	18
M22 G HPA GSP	19
M22 P HTi	20
M22 P HPA	22
M22 P BasiK HPA	24
M22 P WBE HPA	25
M22 P HTV	26
M22 P HTV	27
M22 A HPA	28
M22 A BasiK HPA	29
S3 G HTi	31
S3 G HPA	32
S3 A HPA	33
S3 P HTi	34
S3 P HPA	35
Glue gun 237	37
Small manual glue gun 238	37
<b>MODULAR AUTOMATIC GUNS</b>	<b>40</b>
A35 HTi spray gun - Stainless Steel	40
A 35 HPA spray gun - Stainless Steel	42
A25F HPA Flowmax® gun - Stainless Steel	44
<b>NON-MODULAR AUTOMATIC GUNS</b>	<b>46</b>
A 29 HTi Spray Gun	46
A 29 HPA Spray Gun	48
A28 HPA Spray gun - Stainless steel	50
A3 HPA Spray Gun	52
<b>AIRSPRAY PUMPS</b>	<b>54</b>
PMP 150 pump	54
PMP 150 Pratik pump	56
PMP 150 E Pump	57
PMP 150 transfer pump	58
PDM 01.175 pump	59
Airspray 02C85 paint pump	60
Airspray 04C240 paint pump - Stainless steel	61
Airspray 08C240 paint pump - stainless steel	62
<b>FLOWMAX® PUMPS</b>	<b>63</b>
PCS 03R440 FLOWMAX® Airspray paint circulating system pump	63
Airspray 04F240 FLOWMAX® paint pump - stainless steel	64
PCS 04F440 FLOWMAX® Airspray paint pump - stainless steel	65
PCS 06R440 FLOWMAX® Airspray paint circulating system pump	66
Airspray 08F240 FLOWMAX® paint pump - stainless steel	67
PCS 08F440 FLOWMAX® Airspray paint pump - stainless steel	68
<b>PRESSURE POTS</b>	<b>69</b>
Pressure pots	69
Stainless steel pressure pots	70
<b>HEATERS</b>	<b>72</b>
BP 60 HEATERS	72
AD 60/61 HEATERS  non explosive	73
<b>CTM COLOR CHANGE VALVES</b>	<b>75</b>
<b>PRESSURE REGULATOR</b>	<b>76</b>
<b>FILTRATION</b>	<b>77</b>
<b>AGITATORS</b>	<b>80</b>
Cyclix™ agitators for 20-40-200 l drums	80
<b>HOSES</b>	<b>82</b>
<b>MISCELLANEOUS</b>	<b>84</b>
<b>PROTECTION</b>	<b>85</b>
RC 600 full visor mask	85
RC 756 respirators	86
<b>MECHANICAL MIXING</b>	<b>90</b>
PU 2125 F pump	90
<b>ELECTRONIC DOSING</b>	<b>92</b>
PU 3000 2l	92
CYCLOMIX™ Micro and Micro+ PH	94
CYCLOMIX™ Multi and Multi PH	95
CYCLOMIX™ Expert	96
<b>FITTINGS AND AIR TREATMENT</b>	<b>100</b>
<b>PRACTICAL</b>	<b>110</b>

## CHAPTERS

GENERAL INFORMATION	6
AIRSPRAY SPRAYING	13
PLURAL COMPONENT PUMPS AND MACHINES	89
FITTINGS AND AIR TREATMENT	99

# Global presence

## 16 Offices



**CANADA**  
931, Progress Ave, Unit 7  
SCARBOROUGH M1G 3V5  
Tel. : (00) 141 643 15017  
Fax : (00) 141 643 19171



**UNITED STATES OF AMERICA**  
45001 5 Mile Rd.  
PLYMOUTH, MI, 48170  
Tel. : 734-979-0100  
Fax : 734-927-0064

**MEXICO**  
BERNARDO GARZA TREVINO # 1715  
COL DE MAESTRO MONTERREY, N.L  
CP 64180 MEXICO  
Tel. : (81) 1257-1111  
Fax : (81) 1352-8316



**BRAZIL**  
Rua Alfredo Mario Pizotti, N.41  
Vila Guilherme  
SAO PAULO SP  
Tel. : (+ 5511) 2903 1200



**ARGENTINA**  
Avenida Juan Justo, 6021  
C1416DLB CIUDAD DE BUENOS AIRES  
Tel. : +54 11 45 82 89 80  
Fax : +54 11 45 84 66 77



**HEADQUARTERS**  
Sames Kremlin



**GERMANY**  
Moselsstrasse 19  
D-41464 NEUSS  
Tel. : +49 213 13 69 22 00  
Fax : +49 213 13 69 22 22

**SAMES KREMLIN**  
Stains

**PORTUGAL**  
Rua da Silveira, 554 - Tauria  
2410-269 POUSOS LRA  
Tel. : +351 244 848 220  
Fax : +351 244 848 229



**SPAIN**  
C/Botánica, 49  
08908 L'HOSPITALET DE LLOBREGA  
BARCELONA  
Tel. : +34.932641540  
Fax : + 34.932632829



**SOUTH AFRICA**  
Block G, Hurlingham Office Park, Hurlingham  
Johannesburg  
Tel: +27 (11) 285 0040





# Global presence

**RUSSIA**

23 Street Radionava Office 21  
603093 NIZHNI NOVGOROD  
Tel. : 007 831 467 8981



**POLAND**

Modlinska 221B  
03120 - WARSZAWA  
Tel. : + 48 225 10 38 50  
Fax : + 48 225 10 38 77



**ITALIA**

Linate Business Park  
Strada Provinciale Rivoltana 35  
20096 Pioletto (MI)  
Tel. : (+39) 02 - 48952815  
Fax : (+39) 02 - 48300071



**JAPAN**

Takashima 2-19-12 - Sky Blig 20F  
220-0003 YOKOHAMA - Nishi kanagawa  
TEL: 045 412 5800  
FAX: 045 412 5801  
Mobile: 080 4203 3030



**CHINA**

Building No.9, No.3802 Shengang Road  
Songjiang District  
SHANGHAI 201413  
Tel. : 021-5438 6060  
Fax : 021-5438 6090



**INDIA**

GAT no - 634, PUNE NAGAR Road, Wagholi  
PUNE - 412 207  
Tel : +91 20 30472700/01  
Fax : +91 20 30472710



**SINGAPORE /SOUTH EAST ASIA**

German Centre  
International Business Park #05-109E  
SINGAPORE 609916  
Tel. : +65 65628290  
Fax : +65 68359096



Office



Application Center

# Paint

Decoration and protection are often two associated functions. To achieve these aims, and to re-finish products, we have at our disposal a tremendous number of surface treatments, (for example nickel or chrome plating etc.).

Paint is also perfect for both of these functions. In addition, paint is universally used, and can be applied on any surface, such as wood, metal, stone, leather, plastic and elastomers. Paint does not come as a finished product, and hence the quality of application will depend on all its stages of preparation, which we will call the "Painting System".

In general , the stages are as follows:

- » Surface preparation
- » Application of the coating (paints, stains, varnishes, etc...)
- » Drying

**DISCOVER IN THE GENERAL CATALOGUE AND FOR EACH equipment, Recommended paint families, water-based or solvent-based.**



**WATER-BASED MATERIALS**



**SOLVENT-BASED MATERIALS**



**1. PRIMERS**



**2. STAINS**



**3. DIRECT GLOSS/METALLIC**



**4. TOP COATS/HIGH GLOSS**



**5. UV PRODUCTS**



**6. MOISTURE-SENSITIVE MATERIALS**



**7. ANTI-CORROSION - ABRASIVES**

## SURFACES PREPARATION

There is a wide range of physical and chemical treatments to which the surface to be coated can be subjected, before receiving the first coat.

Good surface preparation is the essential base for long-lasting protection and a good visual finish on any material.

The surface preparation is often the longest, and therefore the most important task involved in coating a part.

Material	Physical preparation	Chemical preparation
Steel:	stripping, shotblasting, brushing	acid
Aluminum:	Brushing	Vapor blast
Wood:	Sanding	
Plastic:	heating	plasma torch, acid

**Once treated, the surfaces should be free from:**

- » particulate or non-adherent substances
- » oil, grease and moisture

**To obtain the best protection against corrosion (mainly for metal), we coat with either:**

- » a wash primer or
- » an anti-corrosion paint

A **wash primer** is a liquid product of around 16s Zahn#2, which should be sprayed in a thin coat, to get into all the imperfections in the surface of the metal. The phosphoric acid which it contains attacks the surface of the metal and forms an isolating and impenetrable layer of phosphate. The wash primer is highly valued for its adhesion to the metal. Importantly, it should then be coated with a layer of paint, which plays the role of a protective shield.

An **anti-corrosion** paint is a product which should be sprayed in a thicker layer than the wash primers. Containing anti-corrosive elements, it has the advantage of protecting the metal both physically and chemically at the same time. Also, it saves time, as a single coat applies both the anti-corrosive chemicals and the protective shield to the metal.

These paints are used very frequently on metal framework, as the coating can be left as it is, or covered subsequently with the desired paint finish.



16s CA<sub>4</sub>



40s CA<sub>4</sub>



# Paint

Looking at a painted object will tell us that paint is hard. However, the paint which we spray is a liquid.

This transformation is due in the main part to several components of paint whose functions are described below.

## COMPONENTS OF PAINT

Paint contains one or more substances which are generally dissolved in a solvent (or in water) and which regain their solid consistency after drying on the surface.

**Amongst these substances, we find:**

- » Binders
- » Pigments
- » Fillers

The binder is generally a more or less transparent body which resembles a resin. Dissolved on its own in a solvent it produces a lacquer:

**Binder + Solvent = Lacquer**

Paint often bears the name of the type of solvent on which it is based (cellulose paint is based on a cellulose solvent). To darken the finish, we add highly colored and very fine powders, which we call pigments:

**Binder + Solvent + Pigments = Paint**

### Dry and wet layer

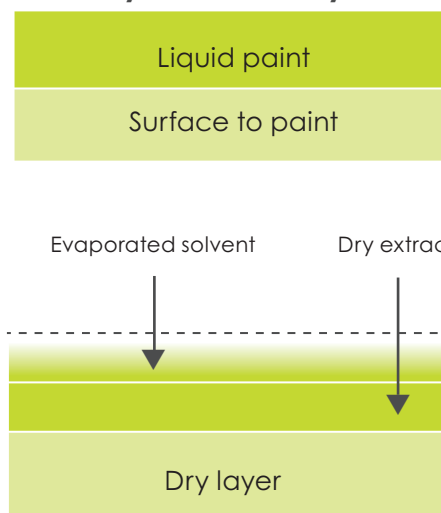

## GLOSSARY

» **Sticky film:** we say that a film is sticky when we put a finger on it and it feels like adhesive tape

» **Dust-free film:** we say that the film is dust-free, when any dust which lands on it can be removed by blowing

» **Film that is dry to the touch:** we say that the film is dry to the touch when a finger does not leave a mark on the surface.

» **Finger-nail hard:** we say that the film is finger-nail hard when we cannot mark it. In this state, it can be polished or sanded.

# Paint

Finally, to give the finish specific characteristics, we use a whole range of fillers and additives. Solvents make it possible to dissolve the other components of the paint, and can be classed into the following three groups:

» **Fast solvents:** they evaporate extremely quickly, to such an extent that the paint can dry too quickly, not allowing it enough time to adhere correctly to the surface.

These solvents are never used on their own.

» **Slow solvents:** they evaporate very slowly, allowing the paint to adhere properly. They leave a soft and smooth finish.

Slow solvents are not very widely used because they significantly increase the drying time.

» **Medium solvents:** they evaporate in a few seconds; this is enough to ensure good adhesion, while giving a satisfactory drying time.

In order to make the correct paint, the manufacturer first of all makes a list of the solvents capable of dissolving all the binders he wishes to include, and then chooses those with a volatility suitable for the planned method of drying (whether at room-temperature or in an oven). Before application, paint is often reduced to give a consistency which is ideal for the task.

## PAINT CONSISTENCY

### Viscosity

The consistency of the paint should be adapted for the type of application. It is identified by the extent of its viscosity, which is expressed in centipoises or by measuring the time in seconds that it takes for a certain amount of paint to run through a calibrated viscosity cup. There are different viscosity cups used for measuring the viscosity of paints. The table below shows the relationship between cup size and viscosities in Centipoises.

AFNOR 4 (CA4)	ISO 4	mPas.s	Centipoises	Ford 4 (CF4)	DIN 4 (D°)	CH (Fr)	ZAHN (n°2)
12	-	20	20	10	11	6	18
14	17	25	25	12	12	7	19
16	23	30	30	14	14	-	20
20	34	40	40	18	16	8	22
25	51	50	50	22	20	9	24
29	60	60	60	25	23	10	27
32	68	70	70	28	25	-	30
34	74	80	80	30	26	11	34
37	82	90	90	33	28	12	37
40	93	100	100	35	30	13	41
45	-	120	120	40	34	14	49
50	-	140	140	44	38	15	58
56	-	160	160	50	42	16	66
61	-	180	180	54	45	17	74
66	-	200	200	58	49	18	82
70	-	220	220	62	52	19	-

Nota: 1 poise = 100 centipoises and 1 mPas.s = 1 centipoise (If the density of the paint is equal as 1 and if it is a fluid Newtonien, that is to say no thixotrope).

## THE EFFECT OF TEMPERATURE ON VISCOSITY

Viscosity of paint changes with variations in temperature; basically, the resins are far more fluid when they are hot.

The table below shows the changes in viscosity of a glycerophthalic paint as the temperature varies. It is worth noting that a paint which has a viscosity of 22s at 68°F will have a viscosity of 28s at 54°F and of 17s at 90°F.

		Temperatures (°C)																			
		2	4	6	8	10	12	14	16	18	20	22	24	26	28	30	32	34	36	38	40
V I S C O S I T Y  I N  S E C O N D S  C F # 4	27	26	24	23	22	21	21	20	19	18	18	17	17	16	15	15	14	14	14	14	
	33	31	29	27	26	25	23	22	21	20	19	18	18	17	16	16	15	15	14	14	
	39	36	34	32	30	28	26	24	23	22	21	20	19	18	17	17	16	15	15	14	
	46	42	39	36	34	31	29	27	26	24	23	22	21	19	18	17	17	16	15	15	
	54	49	45	41	38	35	32	30	28	26	24	23	21	20	19	18	17	17	16	15	
	56	51	47	43	40	36	33	31	29	27	25	23	21	20	20	19	18	17	16	16	
	61	55	50	46	42	38	35	32	30	28	26	24	22	21	20	19	18	17	16	16	
	69	63	56	52	46	42	39	35	32	30	28	25	24	23	21	20	19	18	17	16	
	77	69	62	55	50	46	41	38	35	32	29	27	25	24	22	21	19	18	17	16	
	84	74	67	61	54	50	44	40	36	34	30	28	26	25	23	22	20	18	17	16	
	95	84	75	66	60	54	48	44	40	36	33	30	28	26	24	22	20	19	18	17	
	104	92	81	73	65	58	52	46	42	38	35	31	29	27	24	23	21	20	19	18	
	112	100	88	76	69	62	54	49	44	40	36	32	30	27	25	23	21	20	19	18	
	122	108	90	85	75	66	59	53	47	42	38	35	31	28	26	24	22	21	19	18	
	132	120	102	90	80	70	63	55	50	44	40	36	33	30	27	25	23	22	20	18	
	142	124	108	95	84	74	65	58	52	46	41	37	34	31	27	25	23	22	20	18	
152	132	119	101	90	80	69	61	54	48	43	38	35	31	28	26	24	23	21	18		
164	140	123	106	94	83	73	64	56	50	45	40	36	32	29	27	24	23	21	18		

Example : at a temperature de 20°C for an announced viscosity of 22 s, you should be ready for the following results:

- ▶ at 12°C, a viscosity of 28 s,
- ▶ at 32°C, a viscosity of 17 s.

# Paint

Quality problems tend to arise when the temperature of the paint changes during the course of the day. For example: During the course of this day, the viscosity of the paint has moved from 23 to 17 seconds, which leads to a 22% increase in the output of the spray guns, leading to over-coloring and excessive product consumption.

	Temperatures (°C)	Viscosity - CA4 (seconds)	Spray gun output (cm <sup>3</sup> /mm)
morning, cool workshops	15	23	460
Later - workshop heats up	20	20	520
An oven switched on	25	17	560

Worse still, paint prepared in a hot workshop at 20 seconds can be at 28 seconds the following morning, before the workshop has got up to full working temperature: this would lead to a less fine spray and a much greater drying time.

## DRYING OF PAINTS

the component of paint can be classed in two groups:

» Dry extracts

» VOC (Volatile organic compounds), or water in case of water-based paints

Drying paint is all about allowing the volatile products to evaporate and the film to harden. We must distinguish between hardening and drying.

Drying gives us the dry film purely by the evaporation of the volatile products. This happens at two stages: during spraying and within the film. Depending on the temperature, the density of the spray, the type of spray gun and the distance of the spray, the paint can arrive on the surface more or less dry. That means that the majority of the solvent has evaporated before the paint reaches the surface. The drying of the wet film is accelerated when the surface is in a well-ventilated area which has dry air and is dust-free.





# AIRSPRAY SPRAYING

Airspray spraying

Plural component pumps and machines

Fittings and air treatment

# M22 G HTi

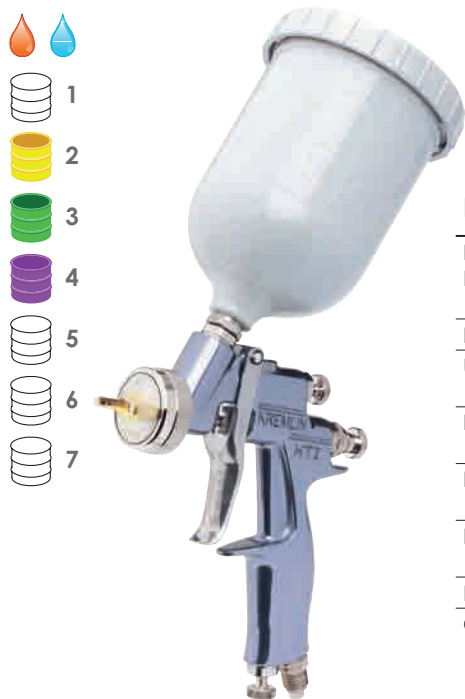

The M22 G HTi is a gravity fed gun that delivers high finish quality and transfer efficiency with outstanding operator comfort. Available with one of 2 aircaps; EP5 for hard to atomize coatings such as high solids and waterbornes or the E5 K HVLP for optimizing efficiency and HVLP compliant airspray.

### FEATURES

- New ergonomics and body design  
Reduced trigger effort
- Product fluid passages in stainless steel
- Unique aircap design
- High transfer efficiency
- Fine thread stuffing box
- E-Z adjust aircap
- Reduced number of components
- Choice of two 0.6 l cups available

### BENEFITS

- The gun is part of the operator's arm who can focus on the application and the spraying movement for an improved quality
- Compatible with water-based materials
- Unsurpassed finish quality with perfectly balanced fan
- Important product savings and environmental protection
- Fine control of the needle tightening torque for an improved sealing
- Allows adjustment without loosening the retaining ring
- Easy maintenance
- Polyacetal white cup for water and solvent-based materials
- PeHD grey cup for pre-catalysed or PU materials

### SPECIFICATIONS

Sprayed materials	Varnishes, lacquers, stains, polyurethans, two component
Body of the gun	Anodized Forged Aluminum
Maximum air inlet pressure (bar)	6
Recommended atomization air pressure at the handle (bar)	EP5: 2 - 3 E5 K HVLP: 1.5 - 2.5
Air consumption (m <sup>3</sup> /h)	EP5: 20.2 à 2.5 bar E5 K HVLP: 27.2 à 2 bar
Weight (with cup) (g)	680
Maximum Fluid Temperature (°C)	50
Transfer efficiency in % (EN 13966-1)	EP5: 74% E5 K HVLP: 76%
Nozzle	Stainless steel
Needle	Stainless steel
Wetted parts	Stainless steel

### FITTINGS

Fitting	Air Inlet	M 1/4" NPS (+ M 1/4" BSP)
	Fluid inlet (gravity cup)	-

### AIRCAP E5 K HVLP



















#### CONFIGURATION OF THE M22 G HTI WITH E5 K HVLP AIRCAP

Max Fluid viscosity in CA 4	Projector type	Nozzles Size (mm)	Fluid output (cc/mn)	Fan width at 20 cm (cm)	Cup	Part number
-	-	-	-	-	Polyacetal 0.6L (White)	136.130.100
-	-	-	-	-	PeHD 0.6L (Grey)	136.131.100
< 20 s	12 E5 K HVLP	1.2	128	22	Polyacetal 0.6L (White)	136.130.101
					PeHD 0.6L (Grey)	136.131.101
	13 E5 K HVLP	1.3	170	25	Polyacetal 0.6L (White)	136.130.102
					PeHD 0.6L (Grey)	136.131.102
20 - 40 s	14 E5 K HVLP	1.4	216	25	-	135.130.103
					Polyacetal 0.6L (White)	136.130.103
	15 E5 K HVLP	1.5	245	35	PeHD 0.6L (Grey)	136.131.103
					-	135.130.104
18 E5 K HVLP	1.8	260	36.5	Polyacetal 0.6L (White)	136.130.104	
				PeHD 0.6L (Grey)	136.131.104	
> 40 s	22 E5 K HVLP	2.2	280	38	-	135.130.105
					Polyacetal 0.6L (White)	136.130.105
	22 E5 K HVLP	2.2	280	38	PeHD 0.6L (Grey)	136.131.105
					Polyacetal 0.6L (White)	136.130.106
					PeHD 0.6L (Grey)	136.131.106



### M22 G HTi

#### PROJECTORS FOR GRAVITY M22 G HTi E5 K HVLP

Max Fluid viscosity in CA 4	Nozzles Size (mm)	Air consumption (m <sup>3</sup> /h)	Fluid output (cc/mn)	Fan width at 20 cm (cm)	Projector Type	Projector Part number	Nozzle	Aircap	Needle
	1.2	27.2	128	22	12 E5 K HVLP	031.130.001			
< 20 s	1.3		170	25	13 E5 K HVLP	031.130.002			
	1.4		216	31	14 E5 K HVLP	031.130.003			
20 - 40 s	1.5		245	35	15 E5 K HVLP	031.130.004			
	1.8		260	36.5	18 E5 K HVLP	031.130.005			
> 40 s	2.2		280	38	22 E5 K HVLP	031.130.006			



















(1) polyacetal end needle

#### AIRCAP EP5

##### CONFIGURATION OF THE M22 G HTi WITH EP 5 AIRCAP

Max Fluid viscosity in CA 4	Projector type	Nozzles Size (mm)	Fluid output (cc/mn)	Fan width at 20 cm (cm)	Cup	Part number
-	-	-	-	-	Polyacetal 0.6L (White)	136.130.100
-	-	-	-	-	PeHD 0.6L (Grey)	136.131.100
< 20 s	12 EP 5	1.2	141	21	Polyacetal 0.6L (White)	136.130.111
					PeHD 0.6L (Grey)	136.131.111
	13 EP 5	1.3	176	22	Polyacetal 0.6L (White)	136.130.112
					PeHD 0.6L (Grey)	136.131.112
20 - 40 s	14 EP 5	1.4	225	28	Polyacetal 0.6L (White)	136.130.113
					PeHD 0.6L (Grey)	136.131.113
	15 EP 5	1.5	255	29	Polyacetal 0.6L (White)	136.130.114
					PeHD 0.6L (Grey)	136.131.114
> 40 s	18 EP 5	1.8	278	30.5	Polyacetal 0.6L (White)	136.130.115
					PeHD 0.6L (Grey)	136.131.115
	22 EP 5	2.2	280	32	Polyacetal 0.6L (White)	136.130.116
					PeHD 0.6L (Grey)	136.131.116

#### PROJECTORS FOR GRAVITY M22 G HTi EP5

Max Fluid viscosity in CA 4	Nozzles Size (mm)	Air consumption (m <sup>3</sup> /h)	Fluid output (cc/mn)	Fan width at 20 cm (cm)	Projector Type	Projector Part number	Nozzle	Aircap	Needle
	1.2	20.2	141	21	12 EP 5	031.130.011			
< 20 s	1.3		176	22	13 EP 5	031.130.012			
	1.4		225	28	14 EP 5	031.130.013			
20 - 40 s	1.5		255	29	15 EP 5	031.130.014			
	1.8		278	30.5	18 EP 5	031.130.015			
> 40 s	2.2		280	32	22 EP 5	031.130.016			

(1) polyacetal end needle

#### MAINTENANCE KITS

Description	Part number
Seal kit	129.130.901
Repair kit (includes the seal kit)	129.130.902

# M22 G HPA



The M22 G HPA is a gravity fed gun that delivers outstanding finish quality with unsurpassed operator comfort. Recommended for hard to atomize coatings.

### FEATURES

New ergonomics and body design  
Reduced trigger effort

Product fluid passages in stainless steel  
Unique aircap design

Fine thread stuffing box

E-Z adjust aircap

Reduced number of components  
Choice of two 0.6 l cups available

### BENEFITS

The gun is part of the operator's arm who can focus on the application and the spraying movement for an improved quality

Compatible with water-based materials  
Unsurpassed finish quality with perfectly balanced fan

Fine control of the needle tightening torque for an improved sealing

Allows adjustment without loosening the retaining ring

Easy maintenance

Polyacetal white cup for water and solvent-based materials  
PeHD grey cup for pre-catalysed or PU materials

### SPECIFICATIONS

Sprayed materials	Varnishes, lacquers, stains, polyurethans, two-component
Body of the gun	Anodized Forged Aluminum
Maximum air inlet pressure (bar)	6
Recommended atomization air pressure at the handle (bar)	2 - 4
Air consumption (m <sup>3</sup> /h)	26.5
Weight (with cup) (g)	680
Maximum Fluid Temperature (°C)	50
Transfer efficiency in % (EN 13966-1)	65%
Nozzle	Stainless steel
Needle	Stainless steel
Wetted parts	Stainless steel

### FITTINGS

Fitting	Air Inlet	M 1/4" NPS (+ M 1/4" BSP)
	Fluid inlet (gravity cup)	-

### M22 G HPA

#### AIRCAP EN 5

#### CONFIGURATION OF THE M22 G HPA GRAVITY

Max Fluid viscosity in CA 4	Projector type	Nozzles Size (mm)	Fluid output (cc/mn)	Fan width at 20 cm (cm)	Cup	Part number
-	-	-	-	-	Polyacetal 0.6L (White)	136.135.100
-	-	-	-	-	PeHD 0.6L (Grey)	136.136.100
< 20 s	12 EN 5	1.2	137	21.5	Polyacetal 0.6L (White)	136.135.101
					PeHD 0.6L (Grey)	136.136.101
	13 EN 5	1.3	173	23.5	Polyacetal 0.6L (White)	136.135.102
					PeHD 0.6L (Grey)	136.136.102
	14 EN 5	1.4	234	27.5	-	135.135.103
					Polyacetal 0.6L (White)	136.135.103
20 - 40 s	15 EN 5	1.5	256	30	PeHD 0.6L (Grey)	136.136.103
					-	135.135.104
> 40 s	18 EN 5	1.8	282	31	Polyacetal 0.6L (White)	136.135.104
					PeHD 0.6L (Grey)	136.136.104
	22 EN 5	2.2	300	32	-	135.135.105
					Polyacetal 0.6L (White)	136.135.105
					PeHD 0.6L (Grey)	136.136.105
					Polyacetal 0.6L (White)	136.135.106
					PeHD 0.6L (Grey)	136.136.106

#### PROJECTORS FOR M22 G HPA SPRAY GUNS

Max Fluid viscosity in CA 4	Nozzles Size (mm)	Air consumption (m <sup>3</sup> /h)	Fluid output M22 G (cc/mn)	Fan width at 20 cm (cm)	Projector		Nozzle	Aircap	Needle
					Type	Part number			
< 20 s	1.2	26.5	137	21.5	12 EN 5	031.135.001	134.130.300	132.130.200	033.130.100
< 20 s	1.3		173	23.5	13 EN 5	031.135.002	134.130.400	132.130.200	033.130.100
< 20 s	1.4		234	27.5	14 EN 5	031.135.003	134.130.500	132.130.200	033.130.200
20 - 40 s	1.5		256	30	15 EN 5	031.135.004	134.130.600	132.130.200	033.130.200
20 - 40 s	1.8		282	31	18 EN 5	031.135.005	134.130.700	132.130.200	033.130.200
> 40 s	2.2		300	32	22 EN 5	031.135.006	134.130.800	132.130.200	033.130.300 <sup>(1)</sup>

(1) polyacetal end needle

#### SEAL KITS

Description	Part number
Seal kit	129.130.901
Repair kit (includes the seal kit)	129.130.902
22-27 needle end kit (x10)	129.140.090

#### NEEDLE WITH POLYACETAL END FOR M22G NEEDLE WITH POLYACETAL END FOR M22 G HTI AND HPA

Description	Nozzles Size (mm)	Part number
Needle with polyacetal end	0.7 - 0.9 - 1.2 - 1.3	033.130.400
Needle with polyacetal end	1.4 - 1.5 - 1.8	033.130.500



# M22 G Basic HPA

Multi-purpose economy gun with good spraying



### FEATURES

- Polished aluminum body
- Product fluid passages in stainless steel
- New design of the BA aircap
- E-Z adjust aircap
- 0.6 l polyacetal cup

### BENEFITS

- Easy and quick maintenance
- Compatible with most material
- Spraying quality guaranteed
- Allows adjustment without loosening the retaining ring
- Can be quickly cleaned

### SPECIFICATIONS

Sprayed materials	Varnishes, lacquers, stains, polyurethans, two-component
Body of the gun	Polished Forged Aluminum
Maximum air inlet pressure (bar)	6
Recommended atomization air pressure at the handle (bar)	2
Air consumption (m <sup>3</sup> /h)	28
Weight (with cup) (g)	690
Maximum Fluid Temperature (°C)	50
Transfer efficiency in % (EN 13966-1)	65
Nozzle	Stainless steel
Needle	Stainless steel
Wetted parts	Stainless steel/Aluminum

### FITTINGS

Fitting	Air Inlet	M 1/4" NPS (+ M 1/4" BSP)
	Fluid inlet (gravity cup)	-

### AIRCAP BA5

#### CONFIGURATION OF THE M22 G BASIK HPA

Max Fluid viscosity in CA 4	Projector type	Nozzles Size (mm)	Fluid output (cc/mn)	Fan width at 20 cm (cm)	Cup	Part number
-	-	-	-	-	Polyacetal 0.6L (white)	136.137.100
20 - 40 s	18 BA5	1.8	280	31	Polyacetal 0.6L (white)	136.137.110

#### PROJECTORS FOR M22 G BASIK HPA

Max Fluid viscosity in CA 4	Nozzles Size (mm)	Air consumption (m <sup>3</sup> /h)	Fluid output M22 G (cc/mn)	Fan width at 20 cm (cm)	Type	Projector Part number	Nozzle	Aircap	Needle
20-40	1.8	28	280	31	18 BA 5	031.137.010	134.130.700	132.137.300	033.130.200

### SEAL KITS

Description	Part number
Seal kit	129.130.901
Repair kit (includes the seal kit)	129.130.902

# M22 G HPA GSP

The M22 HPA GSP has our outstanding ergonomic gun body design with a unique combination pressure/gravity cup for hard to atomize coatings such as high solids and waterbornes.

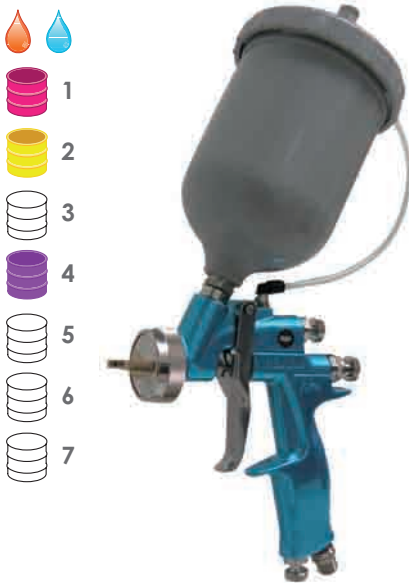

## FEATURES

New ergonomics and body design  
Reduced trigger effort

Pressure cup fitted with a safety valve set at 0,5 bar

Specific design: the cup is only under pressure during application

Product fluid passages in stainless steel

Unique aircap design

Fine thread stuffing box

E-Z adjust aircap

Reduced number of components

## BENEFITS

The gun is part of the operator's arm who can focus on the application and the spraying movement for an improved quality

Full security during application: cup pressure will never exceed 0.5 bar

Full operator safety

Compatible with water-based materials

Unsurpassed finish quality with perfectly balanced fan

Fine control of the needle tightening torque for an improved sealing

Allows adjustment without loosening the retaining ring

Easy maintenance

## SPECIFICATIONS

Sprayed materials	Varnishes, lacquers, stains, polyurethans, two component
Body of the gun	Anodized Forged Aluminum
Maximum air inlet pressure (bar)	6
Recommended atomization air pressure at the handle (bar)	2 - 4
Maximum cup air pressure (bar)	0.5
Air consumption (m <sup>3</sup> /h)	26.5
Weight (with cup) (g)	710
Maximum Fluid Temperature (°C)	50
Transfer efficiency in % (EN 13966-1)	65%
Nozzle	Stainless steel
Needle	Stainless steel
Wetted parts	Stainless steel

## FITTINGS

Fitting	Air Inlet	M 1/4" NPS (+ M 1/4" BSP)
	Fluid inlet (gravity cup - under pressure)	-

## AIRCAPS

### EN5

#### CONFIGURATION OF THE M22 G HPA GSP

Fluid viscosity	Projector type	Nozzles Size (mm)	Fan width at 20 cm (cm)	Cup	Part number
< 3000 cps	15 EN5	1.5	30	PeHD 0.6L (grey)	136.138.104
	18 EN5	1.8	31	PeHD 0.6L (grey)	136.138.105
	22 EN5	2.2	32	PeHD 0.6L (grey)	136.138.106

#### PROJECTORS FOR M22 G HPA GSP SPRAY GUNS

Max Fluid viscosity in CA 4	Nozzles Size (mm)	Air consumption (m <sup>3</sup> /h)	Fan width at 20 cm (cm)	Type	Projector Part number	Nozzle	Aircap	Needle
20 - 40 s	1.5	26.5	30	15 EN 5	031.135.004	134.130.600	132.130.200	033.130.200
20 - 40 s	1.8	26.5	31	18 EN 5	031.135.005	134.130.700	132.130.200	033.130.200
> 40 s	2.2	26.5	32	22 EN 5	031.135.006	134.130.800	132.130.200	033.130.300 <sup>(1)</sup>

(1) polyacetal end needle

## SEAL KITS

Description	Part number
Seal kit	129.130.901
Repair kit (includes the seal kit)	129.130.902
22-27 needle end kit (x10)	129.140.090

# M22 P HTi



The M22P HTi gun delivers high finish quality and transfer efficiency with outstanding operator comfort. Available with one of two aircaps; EP3, for hard to atomize coatings such as high solids and waterbornes or E3 K HVLP, our HVLP highest efficiency and HVLP compliant aircap.

### FEATURES

New ergonomics and body design  
Reduced trigger effort

Product fluid passages in stainless steel  
Unique aircap design

High transfer efficiency

Fine thread stuffing box

E-Z adjust aircap

Reduced number of components

### BENEFITS

The gun is part of the operator's arm who can focus on the application and the spraying movement for an improved quality

Compatible with water-based materials  
Unsurpassed finish quality with perfectly balanced fan

Important product savings and environmental protection

Fine control of the needle tightening torque for an improved sealing

Allows adjustment without loosening the retaining ring

Easy maintenance

### SPECIFICATIONS

Sprayed materials	Varnishes, lacquers, stains, polyurethans, two-component
Body of the gun	Anodized Forged Aluminum
Maximum air inlet pressure (bar)	6
Recommended atomization air pressure at the handle (bar)	1.5 - 2.5
Maximum fluid pressure (bar)	6
Air consumption (m <sup>3</sup> /h)	EP3: 20.2 - 29 E3 K HVLP: 23 - 33 <sup>(1)</sup>
Weight (g)	520
Maximum Fluid Temperature (°C)	50
Transfer efficiency in % (EN 13966-1)	EP3: 72% E3 K HVLP: 75%
Nozzle	Stainless steel
Needle	Treated stainless steel
Wetted parts	Stainless steel

(1) (0.7 bar at the aircap - 2 bar at the handle)

### FITTINGS

Fitting	Air Inlet	M 1/4" NPS
	Fluid Inlet	M 3/8" NPS











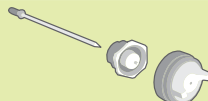



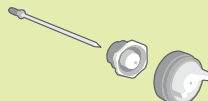



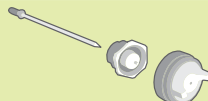

### M22 P HTi

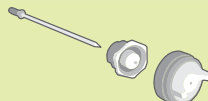
#### AIRCAP E3 K HVLP

##### CONFIGURATION OF THE M22 P HTI WITH E 3 K HVLP AIRCAP

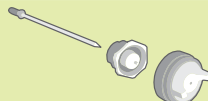
Max Fluid viscosity in CA 4	Projector type	Nozzles Size (mm)	Fluid output (cc/mn)	Fan width at 20 cm (cm)	Part number
-	-	-	-	-	135.140.200
< 20 s	07 E3 K HVLP	0.7	200	32.5	135.140.201
	09 E3 K HVLP	0.9	250	38	135.140.202
	12 E3 K HVLP	1.2	300	42	135.140.203
20 - 40 s	15 E3 K HVLP	1.5	350	46	135.140.206
	18 E3 K HVLP	1.8	400	48	135.140.207

##### PROJECTORS FOR PRESSURE M22 HTI E3 K HVLP





















Max Fluid viscosity in CA 4	Nozzles Size (mm)	Air consumption (m³/h)	Fluid output (cc/mn)	Fan width at 20 cm (cm)	Projector		Nozzle	Aircap	Treated needle
					Type	Part number			
< 20 s	0.7	23	200	32.5		031.140.001			
	0.9	26	250	38		031.140.002			
	1.2	28	300	42		031.140.003			
20 - 40 s	1.5	31	350	46		031.140.006			
	1.8	33	400	48		031.140.007			

#### AIRCAP EP 3

##### CONFIGURATION OF THE M22 P HTI WITH EP 3 AIRCAP

Max Fluid viscosity in CA 4	Projector type	Nozzles Size (mm)	Fluid output (cc/mn)	Fan width at 20 cm (cm)	Part number
-	-	-	-	-	135.140.200
< 20 s	07 EP 3	0.7	200	28.5	135.140.211
	09 EP 3	0.9	250	34	135.140.212
	12 EP 3	1.2	300	37	135.140.213
20 - 40 s	15 EP 3	1.5	350	39	135.140.216
	18 EP 3	1.8	400	42	135.140.217

##### PROJECTORS FOR PRESSURE M22 HTI EP3

Max Fluid viscosity in CA 4	Nozzles Size (mm)	Air consumption (m³/h)	Fluid output (cc/mn)	Fan width at 20 cm (cm)	Projector		Nozzle	Aircap	Treated needle
					Type	Part number			
< 20 s	0.7	20.2	200	28.5		031.140.011			
	0.9	22.5	250	34		031.140.012			
	1.2	24	300	37		031.140.013			
20 - 40 s	1.5	27	350	39		031.140.016			
	1.8	29	400	42		031.140.017			

#### SEAL KITS

Description	Part number
Seal kit	129.130.901
Repair kit (includes the seal kit)	129.140.902



#### M22 P HTI GUN KITS

Kit designation	Kit part number
M22 P HTi 12 EP3 gun kit, fluid and air hoses Ø7 length 7.5m, hose sleeve	151.260.785
M22 P HTi 9 E3 K HVLP gun kit, Ø7 fluid and Ø8 air hoses length 7.5m, hose sleeve	151.260.780

# M22 P HPA

The M22 P HPA uses our new gun body design for outstanding operator comfort.



### FEATURES

New ergonomics and body design  
Reduced trigger effort

Product fluid passages in stainless steel  
Unique aircap design

Fine thread stuffing box

E-Z adjust aircap

Reduced number of components

### BENEFITS

The gun is part of the operator's arm who can focus on the application and the spraying movement for an improved quality

Compatible with water-based materials

Unsurpassed finish quality with perfectly balanced fan

Fine control of the needle tightening torque for an improved sealing

Allows adjustment without loosening the retaining ring

Easy maintenance

### SPECIFICATIONS

Sprayed materials	Varnishes, lacquers, stains, polyurethans, two-component
Body of the gun	Anodized forged aluminum
Maximum air inlet pressure (bar)	6
Recommended atomization air pressure at the handle (bar)	1,5 - 2,5
Maximum fluid pressure (bar)	6
Air consumption (m <sup>3</sup> /h)	28 - 36,1
Weight (g)	520
Maximum Fluid Temperature (°C)	50
Transfer efficiency in % (EN 13966-1)	EN3: 63%
Nozzle	Stainless steel
Needle	Treated stainless steel
Wetted parts	Stainless steel

### FITTINGS

Fitting	Air Inlet	M 1/4" NPS
	Fluid Inlet	M 3/8" NPS



### M22 P HPA

#### AIRCAP EN 3

##### CONFIGURATION OF THE M22 P HPA WITH EN3 AIRCAP

Max Fluid viscosity in CA 4	Projector type	Nozzles Size (mm)	Fluid output (cc/mn)	Air consumption (m³/h)	Fan width at 20 cm (cm)	Part number
-	-	-	-	-	-	135.145.200
< 20 s	07 EN 3	0.7	200	28	27.5	135.145.201
	09 EN 3	0.9	250	30	31	135.145.202
	12 EN 3	1.2	300	32.5	35	135.145.203
20 - 40 s	15 EN 3	1.5	350	34	36	135.145.206
	18 EN 3	1.8	400	36.1	39	135.145.207



#### PROJECTORS FOR M22 P HPA SPRAY GUNS

Max Fluid viscosity in CA 4	Nozzles Size (mm)	Air consumption (m³/h)	Fluid output (cc/mn)	Fan width at 20 cm (cm)	Type	Projector Part number	Nozzle	Aircap	Treated needle
< 20 s	0.7	28	200	27.5	07 EN 3	031.145.001	134.130.100	132.140.200	033.140.100
< 20 s	0.9	30	250	31	09 EN 3	031.145.002	134.130.200	132.140.200	033.140.100
< 20 s	1.2	32.5	300	35	12 EN 3	031.145.003	134.130.300	132.140.200	033.140.100
20 - 40 s	1.5	34	350	36	15 EN 3	031.145.006	134.130.600	132.140.200	033.140.200
	1.8	36.1	400	39	18 EN 3	031.145.007	134.130.700	132.140.200	033.140.200
> 40 s	2.3	17.5	400	36	23 ER 3	031.145.014	134.131.100	132.145.200	033.140.300 <sup>(1)</sup>
	2.7	17.9	500	36	27 ER 3	031.145.015	134.131.200	132.145.200	033.140.300 <sup>(1)</sup>
	2.3	20.6	400	23	23 ER 4	031.145.016	134.131.100	132.145.300	033.140.300 <sup>(1)</sup>
	2.7	20.9	550	23	27 ER 4	031.145.017	134.131.200	132.145.300	033.140.300 <sup>(1)</sup>
	2.3	13.6	360	12	23 ER 9	031.145.020	134.131.100	132.145.500	033.140.300 <sup>(1)</sup>
> 5000 cps	2.7	13.9	400	15	27 ER 9	031.145.021	134.131.200	132.145.500	033.140.300 <sup>(1)</sup>
	3.3	22	300	36	33 ES 3	031.145.018	134.131.300	132.145.400	033.140.400 <sup>(1)</sup>
	4.0	22	470	36	40 ES 3	031.145.019	134.131.400	132.145.400	033.140.400 <sup>(1)</sup>
> 5000 cps	3.3	22	700	12	33 ES 9	031.145.022	134.131.300	132.145.600	033.140.400 <sup>(1)</sup>
	4.0	22	750	15	40 ES 9	031.145.023	134.131.400	132.145.600	033.140.400 <sup>(1)</sup>

<sup>(1)</sup> polyacetal end needle

#### AIRCAP EG 1

##### PROJECTORS FOR M22 P HPA SPRAY GUNS FOR GLUES

Max Fluid viscosity in CA 4	Nozzles Size (mm)	Air consumption (m³/h)	Fluid output (cc/mn)	Fan width at 20 cm (cm)	Type	Projector Part number	Nozzle	Aircap	Treated needle
> 30s	1.5	19.9	350	36	15 EG 1	031.145.024	134.131.500	132.145.700	033.140.200
> 30s	1.8	20.1	400	39	18 EG 1	031.145.025	134.131.600	132.145.700	033.140.200

#### SEAL KITS

Description	Part number
Seal kit	129.130.901
Repair kit (includes the seal kit)	129.140.902
22-27 needle end kit (x10)	129.140.090
33-40 needle end kit (x10)	129.140.091



#### M22 P HPA GUN KITS

Kit designation	Kit part number
M22P 15 EN3 gun kit, Ø7 fluid and air hoses, 7.5 m hoses, hoses sleeve	151.260.790
M22P 18 EN3 "glue" gun kit, Ø7 air and polyamide 9.52 fluid hoses, 5 m hoses, hoses sleeve	151.260.795

# M22 P BasiK HPA



The M22 P BasiK HPA is our economy gun with unsurpassed ergonomics. It is a designed for high volume conventional pressure fed spraying.

### FEATURES

- Polished aluminum body
- Product fluid passages in stainless steel
- E-Z adjust aircap
- New design of the BA aircap

### BENEFITS

- Easy and quick maintenance
- Compatible with water-based materials
- Allows adjustment without loosening the retaining ring
- Spraying quality guaranteed

### SPECIFICATIONS

Sprayed materials	Varnishes, lacquers, stains, polyurethans, two-component
Body of the gun	Polished Forged Aluminum
Maximum air inlet pressure (bar)	6
Recommended atomization air pressure at the handle (bar)	1.8 - 4
Air consumption (m <sup>3</sup> /h)	31
Weight (g)	530
Maximum fluid pressure (bar)	6
Transfer efficiency in % (EN 13966-1)	63
Maximum Fluid Temperature (°C)	50
Nozzle	Stainless steel
Needle	Stainless steel
Wetted parts	Stainless steel

### FITTINGS













Fitting	Air Inlet	M 1/4" NPS
	Fluid Inlet	M 3/8" NPS

### AIRCAP BA3

#### CONFIGURATION OF THE M22 P BASIK HPA

Max Fluid viscosity in CA 4	Projector type	Nozzles Size (mm)	Fluid output (cc/mn)	Fan width at 20 cm (cm)	Part number
-	-	-	-	-	 135.147.200
< 20 s	09 BA3	0.9	250	31	135.147.205
	12 BA3	1.2	270	32	135.147.206
20 - 40 s	15 BA3	1.5	350	36	135.147.207
	18 BA3	1.8	400	39	135.147.208

#### PROJECTORS FOR M22 P BASIK HPA

Max Fluid viscosity in CA 4	Nozzles Size (mm)	Air consumption (m <sup>3</sup> /h)	Fluid output M22 G (cc/mn)	Fan width at 20 cm (cm)	Projector		Nozzle	Aircap	Needle
					Type	Part number			
<20 s	0.9	30	250	31	09 BA 3	031.147.005			
20-40 s	1.2	31	270	32	12 BA 3	031.147.006			
20-40 s	1.5	32	350	36	15 BA 3	031.147.007			
20-40 s	1.8	32	400	39	18 BA 3	031.147.008			

### SEAL KITS

Description	Part number
Seal kit	129.130.901
Repair kit (includes the seal kit)	129.140.902

# M22 P WBE HPA

The M22 P WBE HPA uses our new gun body design for outstanding operator comfort. It delivers high volume pressure fed conventional spraying for highly abrasive water-based coatings.



### FEATURES

Product fluid passages in stainless steel  
Polyurethane needle tip and treated metal needle rod and nozzle

### BENEFITS

Compatible with water-based materials  
Wear caused by the use of abrasive products is reduced

### SPECIFICATIONS

Sprayed materials	Water-based abrasive coatings, porcelain enamels
Body of the gun	Polished Forged Aluminum
Maximum air inlet pressure (bar)	6
Inlet air pressure (bar)	2.5 - 3.5
Air consumption (m³/h)	17.5 - 36.1
Weight (g)	520
Maximum Fluid Temperature (°C)	50
Transfer efficiency in % (EN 13966-1)	63%
Nozzle	Treated metal
Needle	Treated metal
Wetted parts	Stainless steel / Polyurethane

### FITTINGS

Fitting	Air Inlet	M 1/4" NPS
	Fluid Inlet	M 3/8" NPS

### AIRCAP EN3

#### CONFIGURATION OF THE M22P WBE HPA SPRAY GUN

Max Fluid viscosity in CA 4	Projector type	Nozzles Size (mm)	Fluid output (cc/mn)	Fan width (cm)	Part number
< 20s	07 EN3	0.7	200	27.5	135.148.201
	09 EN3	0.9	250	31	135.148.202
	12 EN3	1.2	300	35	135.148.203
20 - 40s	15 EN3	1.5	350	36	135.148.206
	18 EN3	1.8	400	39	135.148.207
> 40s	23 ER3	2.3	400	36	135.148.208

#### PROJECTORS FOR M22 WBE HPA SPRAY GUNS

Max Fluid viscosity in CA 4	Nozzles Size (mm)	Air consumption (m³/h)	Fluid output (cc/mn)	Fan width at 20 cm (cm)	Type	Projector Part number	Nozzle	Aircap	Needle
< 20s	0.7	28	200	27.5	07 EN 3	031.148.001	134.135.100	132.140.200	033.148.100
< 20s	0.9	30	250	31	09 EN 3	031.148.002	134.135.200	132.140.200	033.148.100
< 20s	1.2	32.5	300	35	12 EN 3	031.148.003	134.135.300	132.140.200	033.148.100
20 - 40s	1.5	34	350	36	15 EN 3	031.148.006	134.135.600	132.140.200	033.148.100
20 - 40s	1.8	36.1	400	39	18 EN 3	031.148.007	134.135.700	132.140.200	033.148.100
> 40s	2.3	17.5	400	36	23 ER 3	031.148.008	134.136.100	132.145.200	033.148.100

#### SEAL KITS

Description	Part number
Seal kit	129.130.901
Repair kit (includes the seal kit)	129.140.902
Needle tip kit for nozzles sized 7 to 23 (x10)	129.417.005

# M22 P HTV



The M22 P HTV is a pressure fed gun with outstanding ergonomics that uses Kremlin's unique Vortex technology to spray low viscosity materials on sharply profiled surfaces.

## FEATURES

New ergonomics and body design  
Reduced trigger effort

Product fluid passages in stainless steel  
Unique aircap design

High transfer efficiency

Fine thread stuffing box

E-Z adjust aircap

## BENEFITS

The gun is part of the operator's arm who can focus on the application and the spraying movement for an improved quality

Compatible with water-based materials  
Unsurpassed finish quality with perfectly balanced fan

Important product savings and environmental protection

Fine control of the needle tightening torque for an improved sealing

Allows adjustment without loosening the retaining ring

## SPECIFICATIONS

Sprayed materials	Varnishes / Stains
Body of the gun	Anodized Forged Aluminum
Maximum air inlet pressure (bar)	6
Recommended atomization air pressure at the handle (bar)	1.5 - 2.5
Maximum fluid pressure (bar)	6
Air consumption (m <sup>3</sup> /h)	24 <sup>(1)</sup>
Weight (g)	580
Maximum Fluid Temperature (°C)	50
Transfer efficiency in % (EN 13966-1)	65 <sup>(2)</sup>
Nozzle	Stainless steel / PEEK
Needle	Treated stainless steel
Wetted parts	Stainless steel / PEEK

(1) [0,7 bar at the aircap - 2 bar at the handle]  
(2) with 22-06 nozzle

## FITTINGS

Fitting	Air Inlet	M 1/4" NPS
	Fluid Inlet	M 3/8" NPS



# M22 P HTV

## AIRCAP EV3 K HVLP

### CONFIGURATION OF THE M22 P HTV GUN WITH EV3 K HVLP AIRCAP

Max Fluid viscosity in CA 4	Projector type	Nozzles Size (mm)	Fluid output (cc/mn)	Fan width at 20 cm (cm)	Part number
					
14 - 20s	18-04 EV3 K HVLP	0.4	100	25	135.142.201
20 - 30s	18-05 EV3 K HVLP	0.5	240	27.5	135.142.202
30 - 40s	22-06 EV3 K HVLP	0.6	320	30	135.142.203

### PROJECTORS FOR M22 P HTV SPRAY GUNS



Max Fluid viscosity in CA 4	Nozzles Size (mm)	Fan width at 20 cm (cm)	Air consumption (m³/h)	Fluid output (cc/mn)	Nozzle assembly	Aircap	Treated needle
							
14-20 s	18/04	25	24	100	134.142.100	132.142.100	033.142.100
20-30 s	18/05	27.5	24	240	134.142.200	132.142.100	033.142.100
30-40 s	22/06	30	24	320	134.142.300	132.142.100	033.142.100

### SEAL KITS

Description	Part number
Seal kit	129.130.901
Repair kit (includes the seal kit)	129.140.902

### SPECIAL NEEDLES AND NOZZLES FOR M22 P

#### SPECIAL NEEDLES AND NOZZLES FOR M22 P

Description	Designation	Needle	Nozzle
			
207 T	Treated nozzle and needle	033.140.100	134.135.100
209 T	Treated nozzle and needle	033.140.100	134.135.200
212 T	Treated nozzle and needle	033.140.100	134.135.300
215 T	Treated nozzle and needle	033.140.200	134.135.600
218 T	Treated nozzle and needle	033.140.200	134.135.700
223 T	Treated nozzle and needle	033.140.300	134.136.100
227 T	Treated nozzle and needle	033.140.300	134.136.200
233 T	Treated nozzle and needle	033.140.400	134.136.300
240 T	Treated nozzle and needle	033.140.400	134.136.400

### NEEDLE WITH POLYACETAL END FOR M22 P HTI AND HPA

Description	Nozzles Size (mm)	Part number
		
Polyacetal needle end	0.7 - 0.9 - 1.2 - 1.3	033.140.500
Polyacetal needle end	1.4 - 1.5 - 1.8	033.140.600



# M22 A HPA



The M22 A HPA is a suction fed gun with unsurpassed ergonomics designed for hard to atomize coatings. Fine air output adjustment at the handle.

### FEATURES

- New ergonomics and body design
- Reduced trigger effort
- Unique aircap design
- Fine thread stuffing box
- E-Z adjust aircap
- Reduced number of components

### BENEFITS

- The gun is part of the operator's arm who can focus on the application and the spraying movement for an improved quality
- Unsurpassed finish quality with perfectly balanced fan
- Fine control of the needle tightening torque for an improved sealing
- Allows adjustment without loosening the retaining ring
- Easy maintenance

### SPECIFICATIONS

Sprayed materials	Virtually all coatings
Body of the gun	Anodised Forged Aluminum
Maximum air inlet pressure (bar)	6
Recommended atomization air pressure at the handle (bar)	2 - 3
Air consumption (m <sup>3</sup> /h)	23 - 29.7
Weight (with cup) (g)	980
Maximum Fluid Temperature (°C)	50
Transfer efficiency in % (EN 13966-1)	62%
Nozzle	Stainless steel
Needle	Stainless steel
Wetted parts	Stainless steel/aluminum

### FITTINGS















Fitting	Air Inlet	M 1/4" NPS (+ M 1/4" BSP)
	Fluid inlet (SM6 suction cup 1l)	M 3/8" NPS

### AIRCAP EN 2

#### CONFIGURATION OF THE M22 A HPA

Max Fluid viscosity in CA 4	Projector type	Nozzles Size (mm)	Fluid output (cc/mn)	Fan width at 20 cm (cm)	Cup	Part number
-	-	-	-	-	-	
< 20 s	12 EN 2	1.2	100	16	SM6 (1 L)	136.145.200 136.145.211
20 - 40 s	15 EN 2	1.5	223	26.5	(Aluminum)	136.145.212
	18 EN 2	1.8	270	27		136.145.213

#### PROJECTORS FOR SUCTION-FED M22 A HPA GUNS

Max Fluid viscosity in CA 4	Nozzles Size (mm)	Air consumption (m <sup>3</sup> /h)	Fluid output (cc/mn)	Fan width at 20 cm (cm)	Projector Type	Projector Part number	Nozzle	Aircap	Treated needle
< 20 s	1.2	23	100	16	12 EN 2	031.145.011			
20 - 40 s	1.5	27	223	26.5	15 EN 2	031.145.012			
	1.8	29.7	270	27	18 EN 2	031.145.013			
> 40 s	2.3	19	320	30	23 ER 1	031.145.030			
	2.7	20	340	32	27 ER 1	031.145.031			

### SEAL KITS

Description	Part number
Seal kit	129.130.901
Repair kit (includes the seal kit)	129.140.902

# M22 A BasiK HPA

The M22 A BasiK HPA is our economy gun with unsurpassed ergonomics. It is designed for conventional suction fed spraying.



### FEATURES

- Polished aluminum body
- E-Z adjust aircap
- New design of the BA aircap

### BENEFITS

- Easy and quick maintenance
- Allows adjustment without loosening the retaining ring
- Spraying quality guaranteed

### SPECIFICATIONS

Sprayed materials	Virtually all coatings
Body of the gun	Polished Forged Aluminum
Maximum air inlet pressure (bar)	6
Recommended atomization air pressure at the handle (bar)	2.5 - 3.5
Air consumption (m <sup>3</sup> /h)	24
Weight (with cup) (g)	1000
Transfer efficiency in % (EN 13966-1)	62
Maximum Fluid Temperature (°C)	50
Nozzle	Stainless steel
Needle	Stainless steel
Wetted parts	Stainless steel, aluminum

### FITTINGS

Fitting	Air Inlet	M 1/4" NPS (+ M 1/4" BSP)
	Fluid Inlet	M 3/8" NPS

### AIRCAP BA2

#### CONFIGURATION OF THE M22 A BASIK HPA

Max Fluid viscosity in CA 4	Projector type	Nozzles Size (mm)	Fluid output (cc/mn)	Fan width at 20 cm (cm)	Cup	Part number
-	-	-	-	-	SM6 (1L)	136.147.200
20 - 40 s	15 BA2	1.5	220	24.5	SM6 (1L)	136.147.201
	18 BA2	1.8	300	25	SM6 (1L)	136.147.202





#### PROJECTORS FOR M22 A BASIK HPA

Max Fluid viscosity in CA 4	Nozzles Size (mm)	Air consumption (m <sup>3</sup> /h)	Fluid output M22 G (cc/mn)	Fan width at 20 cm (cm)	Projector		Nozzle	Aircap	Needle
					Type	Part number			
20-40	1.5	24	220	24.5	15 BA 2	031.147.001	134.130.600	132.147.100	033.140.200
20-40	1.8	24	300	25	18 BA 2	031.147.002	134.130.700	132.147.100	033.140.200



### SEAL KITS

Description	Part number
Seal kit	129.130.901
Repair kit (includes the seal kit)	129.140.902



**AIRCAPS FOR M22 AIRSPRAY GUNS**  
**AIRCAPS FOR HTI AND HTV AIRSPRAY GUNS**

	E3 K HVLP	E5 K HVLP	EP 3	EP 5	EV 3 K HVLP
					
Guns	M22 P HTi	M22 G HTi	M22 P HTi	M22 G HTi	M22 P HTV
Fan shape	Flat	Flat	Flat	Flat	Flat swirling fan
Atomization Type	HTi	HTi	HTi	HTi	HTi
Atomization quality	Excellent	Excellent	Excellent	Excellent	Excellent
Transfer efficiency	76%	76%	74%	74%	65%
Air consumption @ 2 bar	23 - 33 m <sup>3</sup> /h	27.2 m <sup>3</sup> /h	20.2 - 29 m <sup>3</sup> /h	20.2 m <sup>3</sup> /h	24 m <sup>3</sup> /h
Nozzle size	07/18	12/22	07/18	12/22	04/06







**AIRCAPS FOR HPA AIRSPRAY GUNS**

	EN 5	EN 2	EN 3
			
Guns	M22 G HPA	M22 A HPA	M22 P HPA
Fan shape	Flat	Flat	Flat
Atomization Type	HPA	HPA	HPA
Atomization quality	Very Good	Very Good	Very Good
Transfer efficiency	65%	62%	63%
Air consumption @ 2 bar	26.5 m <sup>3</sup> /h	23 - 29.7 m <sup>3</sup> /h	28 - 36.1 m <sup>3</sup> /h
Nozzle size	12/22	12/18	07/18

**AIRCAPS FOR HPA BASIK AIRSPRAY GUNS**

	BA 5	BA 2	BA 3
			
Guns	M22 G Basik HPA	M22 A Basik HPA	M22 P Basik HPA
Fan shape	Flat	Flat	Flat
Atomization Type	HPA	HPA	HPA
Atomization quality	Good	Good	Good
Transfer efficiency	65%	62%	63%
Air consumption @ 2 bar	28 m <sup>3</sup> /h	24 m <sup>3</sup> /h	32 m <sup>3</sup> /h
Nozzle size	18	15/18	09/12/15/18

**AIRCAPS FOR HPA AIRSPRAY GUNS**

	ER1	ER3	ER4	ER9	ES3	ES9	EG1
							
Gun designation	M22 A HPA	M22 P HPA	M22 P HPA	M22 P HPA	M22 P HPA	M22 P HPA	M22 P HPA
Fan shape	Flat	Flat	Flat	Round	Flat	Round	Flat
Atomization Type	HPA	HPA	HPA	HPA	HPA	HPA	HPA
Atomization quality	Very good	Very good	Very good	Excellent	Good	Very good	Excellent
Nozzle size	23/27	23/27	23/27	23/27	33/40	33/40	15/18

### S3 G HTi

The S3 G HTi is our most compact gravity fed gun with outstanding ergonomics designed for small hands and tight areas where touch up or shading is required.



#### FEATURES

- New ergonomics and body design
- Unique aircap design
- In-line air valve assembly
- 1 finger trigger
- E-Z adjust aircap
- PeHD cup

#### BENEFITS

- The gun is part of the operator's arm who can focus on the application and the spraying movement for an improved quality
- Unsurpassed finish quality with perfectly balanced fan
- Fine adjustment and long lasting components
- For an improved application accuracy
- Allows adjustment without loosening the retaining ring
- Compatible with water-based materials

#### SPECIFICATIONS

Sprayed materials	Shades, varnishes, lacquers, stains, polyurethans, 2 component
Body of the gun	Polished Forged Aluminum
Maximum air inlet pressure (bar)	6
Recommended atomization air pressure at the handle (bar)	1.5 - 2.5
Air consumption (m <sup>3</sup> /h)	7.5 <sup>(1)</sup>
Weight (with cup) (g)	515
Maximum Fluid Temperature (°C)	50
Nozzle	Stainless steel
Needle	Stainless steel
Wetted parts	Stainless steel

(1) (0.7 bar at the aircap - 2 bar at the handle)

#### FITTINGS

Fitting	Air Inlet	M 1/4" NPS
	Fluid inlet (gravity cup)	-











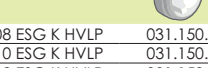

#### AIRCAP

##### ESG K HVLP

##### CONFIGURATION OF THE S3 G HTI SPRAY GUN

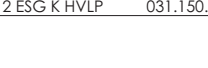
Max Fluid viscosity in CA 4	Projector type	Nozzles Size (mm)	Fluid output (cc/mn)	Fan width at 20 cm (cm)	Cup	Projector Part number
-	-	-	-	-	-	
14 - 20s	08 ESG K HVLP	0.8	68	14	PeHD 0.25L (grey)	136.155.100
14 - 20s	10 ESG K HVLP	1.0	100	21		136.155.112
20 - 30s	12 ESG K HVLP	1.2	130	24		136.155.113
						136.155.114

#### PROJECTORS FOR S3 G HTI SPRAY GUNS

Max Fluid viscosity in CA 4	Nozzles Size (mm)	Air consumption (m <sup>3</sup> /h)	Fluid output (cc/mn)	Fan width at 20 cm (cm)	Type	Projector Part number	Nozzle	Aircap	Needle
<20 s	0.8	7.5	68	14		08 ESG K HVLP 031.150.012			
14 - 20s	1.0	7.5	100	21		10 ESG K HVLP 031.150.013			
20 - 40s	1.2	7.5	130	24		12 ESG K HVLP 031.150.014			

#### SEAL KITS

Description	Part number
Seal kit	129.150.901
Repair kit (includes the seal kit)	129.150.902

# S3 G HPA

The S3 G HPA is our most compact gun designed for small hands and tight areas where touch up or shading is required.



### FEATURES

- New ergonomics and body design
- Reduced air consumption
- In-line air valve assembly
- 2 different projectors: AM and PGL
- 1 finger trigger
- E-Z adjust aircap
- PeHD cup

### BENEFITS

- The gun is part of the operator's arm who can focus on the application and the spraying movement for an improved quality
- Energy savings
- Fine adjustment and long lasting components
- 2 types of application possible: AM (flat fan) and PGL (special line round fan)
- For an improved application accuracy
- Allows adjustment without loosening the retaining ring
- Compatible with water-based materials

### SPECIFICATIONS

Sprayed materials	Shades, varnishes, lacquers, stains, polyurethans, 2 component
Body of the gun	Polished Forged Aluminum
Maximum air inlet pressure (bar)	6
Recommended atomization air pressure at the handle (bar)	2.5 - 3.5
Air consumption (m <sup>3</sup> /h)	8-10
Weight (with cup) (g)	515
Maximum Fluid Temperature (°C)	50
Nozzle	Stainless steel
Needle	Stainless steel
Wetted parts	Stainless steel

### FITTINGS

Fitting	Air Inlet	M 1/4" NPS
	Fluid inlet (gravity cup)	-

### AIRCAP AM PGL

#### CONFIGURATION OF THE S3 G HPA SPRAY GUN

Max Fluid viscosity in CA 4	Projector type	Nozzles Size (mm)	Fluid output (cc/mn)	Fan width at 20 cm (cm)	Cup	Part number
-	-	-	-	-	PeHD 0,25L (grey)	136.155.100
14-20 s	08 AM	0.8	86	15	PeHD 0,25L (grey)	136.155.108
14-20 s	08 AM	0.8	86	15	Polycetal 0,25 l (white)	136.156.108
20-30 s	10 AM	1.0	142	22	PeHD 0,25l (grey)	136.155.109
30-40 s	12 AM	1.2	180	24.5	PeHD 0,25l (grey)	136.155.110
20-30 s	10 PGL	1.0	148	13	PeHD 0,25l (grey)	136.155.107

#### PROJECTORS FOR S3G HPA SPRAY GUNS

Max Fluid viscosity in CA 4	Nozzles Size (mm)	Air consumption (m <sup>3</sup> /h)	Fluid output (cc/mn)	Fan width at 20 cm (cm)	Projector Type	Projector Part number	Nozzle	Aircap	Needle
<20 s	0.8	12.9	86	15	08 AM	031.150.008	134.630.400	132.630.400	033.150.100
	1.0	12.9	142	17	10 AM	031.150.009	134.630.100	132.630.400	033.150.500
	1.2	12.9	180	19	12 AM	031.150.010	134.630.200	132.630.400	033.150.200
20-30 s	1.0	4	148	13	10 PGL	031.150.007	134.640.100	132.640.100	033.150.300

### SEAL KITS

Description	Part number
Seal kit	129.150.901
Repair kit (includes the seal kit)	129.150.902

# S3 A HPA

The S3 A HPA is our most compact suction fed gun with outstanding ergonomics for small hands and tight areas where touch up or shading is required.



### FEATURES

- New ergonomics and body design
- Reduced air consumption
- In-line air valve assembly
- 2-finger trigger
- E-Z adjust aircap
- PeHD cup

### BENEFITS

- The gun is part of the operator's arm who can focus on the application and the spraying movement for an improved quality
- Energy savings
- Fine adjustment and long lasting components
- Improved comfort for more productivity
- Allows adjustment without loosening the retaining ring
- Compatible with water-based materials

### SPECIFICATIONS

Sprayed materials	Shades, varnishes, lacquers, stains, polyurethans, 2 component
Body of the gun	Polished Forged Aluminum
Maximum air inlet pressure (bar)	6
Recommended atomization air pressure at the handle (bar)	2.5 - 3.5
Air consumption (m <sup>3</sup> /h)	8-11
Weight (with cup) (g)	595
Maximum Fluid Temperature (°C)	50
Nozzle	Stainless steel
Needle	Stainless steel
Wetted parts	Stainless steel

### FITTINGS

Fitting	Air Inlet	M 1/4" NPS
	Fluid inlet (0.25l PeHD suction cup)	M 1/4" NPS

### AIRCAP AM AY

#### CONFIGURATION OF THE S3 A HPA SPRAY GUN

Max Fluid viscosity in CA 4	Projector type	Nozzles Size (mm)	Fluid output (cc/mn)	Air consumption (m <sup>3</sup> /h)	Fan width at 20 cm (cm)	Cup	Part number
-	-	-	-	-	-	-	136.150.200
14-20 s	08 AM	0.8	86	12.9	15	PeHD 0.25l (grey)	136.150.208
20-30 s	10 AM	1.0	132	12.9	17		136.150.209
30-40 s	12 AM	1.2	159	12.9	19		136.150.210
	15 AY	1.5	180	14.1	20		136.150.211

#### PROJECTORS FOR S3 A HPA AIRSPRAY GUNS

Max Fluid viscosity in CA 4	Nozzles Size (mm)	Fluid output (cc/mn)	Fan width at 20 cm (cm)	Air consumption (m <sup>3</sup> /h)	Type	Projector Part number	Nozzle	Aircap	Needle
<20 s	0.8	86	15	12.9	08 AM	031.150.008			
	1.0	132	17	12.9	10 AM	031.150.009			
	1.2	159	19	12.9	12 AM	031.150.010			
20-40 s	1.5	180	20	14.1	15 AY	031.150.011			

### SEAL KITS

Description	Part number
Seal kit	129.150.901
Repair kit (includes the seal kit)	129.150.902



# S3 P HTi



The S3 P HTi is our most compact pressure fed gun with outstanding ergonomics designed for small hands and tight areas where touch-up or shading is required.

### FEATURES

- New ergonomics and body design
- Unique aircap design
- E-Z adjust aircap
- In-line air valve assembly
- 2-finger trigger

### BENEFITS

- The gun is part of the operator's arm who can focus on the application and the spraying movement for an improved quality
- Unsurpassed finish quality with perfectly balanced fan
- Allows adjustment without loosening the retaining ring
- Fine adjustment and long lasting components
- Improved comfort for more productivity

### SPECIFICATIONS

Sprayed materials	Shades, varnishes, lacquers, stains, polyurethans, 2 component
Body of the gun	Polished Forged Aluminum
Maximum air inlet pressure (bar)	6
Recommended atomization air pressure at the handle (bar)	1.5 - 2.5
Air consumption (m <sup>3</sup> /h)	12
Weight (g)	388
Maximum fluid pressure (bar)	6
Maximum Fluid Temperature (°C)	50
Nozzle	Stainless steel
Needle	Stainless steel
Wetted parts	Stainless steel

### FITTINGS

Fitting	Air Inlet	M 1/4" NPS
	Fluid Inlet	M 1/4" NPS

### AIRCAP EPX K HVLP

#### CONFIGURATION OF THE S3 P HTI SPRAY GUN

Max Fluid viscosity in CA 4	Projector type	Nozzles Size (mm)	Fluid output (cc/mn)	Fan width at 20 cm (cm)	Part number
-	-	-	-	-	135.150.200
14-20 s	08 EPX K HVLP	0.8	300	25	135.150.204
20-30 s	10 EPX K HVLP	1.0	461	26	135.150.205
30-40 s	12 EPX K HVLP	1.2	745	26	135.150.206

### PROJECTORS FOR S3 P HTI SPRAY GUNS

Max Fluid viscosity in CA 4	Nozzles Size (mm)	Air consumption (m <sup>3</sup> /h)	Fluid output (cc/mn)	Fan width at 20 cm (cm)	Projector		Nozzle	Aircap	Needle
					Type	Part number			
14-20 s	0.8	12	80	25	08 EPX K HVLP	031.150.004	134.630.400	132.150.100	033.150.100
20-40 s	1.0	12	92	26	10 EPX K HVLP	031.150.005	134.630.100	132.150.100	033.150.500
20-40 s	1.2	12	131	26	12 EPX K HVLP	031.150.006	134.630.200	132.150.100	033.150.200

### SEAL KITS

Description	Part number
Seal kit	129.150.901
Repair kit (includes the seal kit)	129.150.902

### S3 P HPA

The S3 P HPA is our most compact pressure fed gun with outstanding ergonomics for small hands and tight areas where touch up or shading is required.



#### FEATURES

- New ergonomics and body design
- Unique aircap design
- E-Z adjust aircap
- Reduced air consumption
- In-line air valve assembly
- 2-finger trigger

#### BENEFITS

- The gun is part of the operator's arm who can focus on the application and the spraying movement for an improved quality
- Unsurpassed finish quality with perfectly balanced fan
- Allows adjustment without loosening the retaining ring
- Energy savings
- Fine adjustment and long lasting components
- Improved comfort for more productivity

#### SPECIFICATIONS

Sprayed materials	Shades, varnishes, lacquers, stains, polyurethans, 2 component
Body of the gun	Polished Forged Aluminum
Maximum air inlet pressure (bar)	6
Recommended atomization air pressure at the handle (bar)	3
Air consumption (m <sup>3</sup> /h)	10
Weight (g)	387
Maximum fluid pressure (bar)	6
Maximum Fluid Temperature (°C)	50
Nozzle	Stainless steel
Needle	Stainless steel
Wetted parts	Stainless steel

#### FITTINGS

Fitting	Air Inlet	M 1/4" NPS
	Fluid Inlet	M 1/4" NPS

#### AIRCAP PX PGL

#### CONFIGURATION OF THE S3 P HPA SPRAY GUN

Max Fluid viscosity in CA 4	Projector type	Nozzles Size (mm)	Fluid output (cc/mn)	Fan width at 20 cm (cm)	Part number
-	-	-	-	-	135.150.200
14-20 s	08 PX	0.8	307	23	135.150.201
20-30 s	10 PX	1.0	506	23.5	135.150.202
30-40 s	12 PX	1.2	731	25	135.150.203
20-30 s	10 PGL	1.0	148	13	135.150.207

#### PROJECTORS FOR M22 P HPA SPRAY GUNS

Max Fluid viscosity in CA 4	Nozzles Size (mm)	Air consumption (m <sup>3</sup> /h)	Fluid output (cc/mn)	Fan width at 20 cm (cm)	Type	Projector Part number	Aircap	Needle	Nozzle
14-20	0.8	10	307	23	08 PX	031.150.001	132.631.100	033.150.100	134.630.400
20-30	1.0	10	506	23.5	10 PX	031.150.002	132.631.100	033.150.500	134.630.100
30-40	1.2	10	731	25	12 PX	031.150.003	132.631.100	033.150.200	134.630.200
20-30 s	1.0	4	148	13	10 PGL	031.150.007	132.640.100	033.150.300	134.640.100

#### SEAL KITS





Description	Part number
Seal kit	129.150.901
Repair kit (includes the seal kit)	129.150.902

**AIRCAPS FOR S3 AIRSPRAY GUNS**

**AIRCAPS FOR HTI AIRSPRAY GUNS**

	ESG K HVLP	EPX K HVLP
		
Guns	S3 G HTi	S3 P HTi
Fan shape	Flat	Flat
Atomization Type	HTi	HTi
Atomization Quality	Excellent	Excellent
Air consumption @ 2 bar	7.5 m <sup>3</sup> /h	12 m <sup>3</sup> /h
Nozzle size	08/12	08/12

**AIRCAPS FOR HPA AIRSPRAY GUNS**

	AM	AM	AY	PX
				
Guns	S3 G HPA	S3 A HPA	S3 A HPA	S3 P HPA
Fan shape	Flat	Flat	Flat	Flat
Atomization Type	HPA	HPA	HPA	HPA
Atomization quality	Very good	Very good	Very good	Very good
Transfer efficiency	72%	52%	54%	76%
Air consumption @ 2 bar	10 m <sup>3</sup> /h	13 m <sup>3</sup> /h	14 m <sup>3</sup> /h	10 m <sup>3</sup> /h
Nozzle size	08/12	08 /15	15	08/12

**AIRCAPS FOR HPA AIRSPRAY GUNS - AIRCAPS FOR THE LINE**

	PGL	PGL
		
Guns	S3 G HPA	S3 P HPA
Fan shape	Line	Line
Atomization type	HPA	HPA
Atomization quality	Very good	Very good
Nozzle size	10	10

# Glue gun 237

Allows precise deposits of straight lines, curves and series of drops of glue according to the tip used.  
Manual or automatic.



manual version



automatic version

### SPECIFICATIONS

Max. fluid pressure (bar)	10
Air consumption (m <sup>3</sup> /h)	1 - 2

### PART NUMBERS

Designation	Type	Tip	Part Number
Glue gun 237	manual	no	129.802.000
	automatic		029.712.000

### TABLE OF THE TIPS

Tip	Type	Part Number
<b>Brush tip</b>		
	Ø 9	034.800.801
	Ø 23	034.800.804
	Ø 35	034.800.805
	width: 50	034.800.807
<b>Curve tip</b>		
	Ø 1	034.340.101
	Ø 2	034.340.201
	Ø 3	034.340.301
	Ø 4	034.340.400
<b>Multi-curve tip</b>		
	width: 50	034.800.200
	width: 100	034.800.600
<b>Profiled tip for grooved surfaces</b>		
	6 - 12	034.802.090
<b>Tip for pins</b>		
	Ø 8-25	034.802.040

# Small manual glue gun 238

Brush with continuous feeding.

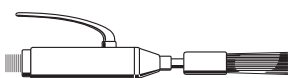

### PART NUMBERS

Designation	Ø	Part Number
Small manual glue gun - without brush		029.803.000
Round brush	9	029.371.013

## Airspray guns accessories

### EXTENSIONS FOR M22 PRESSURE FED GUNS

Designed for painting the inside of tubes (360° circular fan) or the inside of cavities (lateral fan)



### EXTENSIONS FOR PRESSURE-FED M22 SPRAY GUNS

Fan type	Internal diameter (mm)	Length in mm	Nozzle type	Part number
Cone	8	150	12	075.900.213
Cone	8	150	18	075.900.224
Lateral	8	250	12	075.900.111
Lateral	8	250	18	075.900.122
Lateral	8	400	12	075.900.311
Lateral	8	400	18	075.900.322

### GRAVITY CUPS

The white cup is for water or solvent based paints; the grey cup is for polyurethanes and pre-catalyzed paints



### PART NUMBERS GRAVITY CUPS FOR M22G

Description	Material	Capacity (L)	Fitting	Part number
White cup (solvent and water-based paints)	Polyacetal	0.25	M 1/4" BSP	139.280.200
White Cup (solvent or water-based paints)	Polyacetal	0.6	M 1/4" BSP	139.270.200
Grey cup (PU and pre-catalyzed paints)	PeHD	0.6	M 1/4" BSP	139.270.250

### PART NUMBER GRAVITY CUP FOR S3 G

Description	Material	Capacity (L)	Fitting	Part number
White cup (solvent and water-based paints)	Polyacetal	0.25	M 1/4" BSP	139.280.200
Grey cup (PU- and pre-catalysed paints)	PeHD	0.25	M 1/4" BSP	139.280.250

### SEAL PACKS AND SCREENS

Designation	Quantity	Part number
Pack of non-drip plugs for 0.25 liter and 0.6 liter cups	5	139.270.210
Pack of screens for 0.25 liter and 0.6 liter cups (200 µm)	5	139.270.220

### SUCTION CUP - WITH NON-DRIP SYSTEM

1/4 turn quick opening SM6 aluminum twist cup (for M22 and M21 ranges)  
1/4 turn quick opening PeHD cup (for S3A)



### CUP PART NUMBERS FOR M22A

Description	Material	Fitting	Capacity (L)	Part number
Complete SM6 standard suction cup	Aluminum	F 3/8" NPS	1	138.360.000
Fitted cover (with tube)	Aluminum	F 3/8" NPS	-	138.360.200
Cup only	Aluminum	-	1	138.350.100

### CUP PART NUMBER FOR S3 A

Description	Fitting	Material	Capacity (L)	Part number
Suction cup (grey)	F 1/4" NPS	PeHD	0.25	138.390.000

### SEAL PACKS FOR SM6

Description	Quantity	Part number
Pack of cup seals	10	138.010.900
Pack of filters (200 µm)	4	138.310.300
Pack of non-drip plugs	5	138.350.901
Pack of filters for SM5 (old model) (132 µm)	4	138.010.800

### SEAL PACKS FOR S3 A CUP

Description	Quantity	Part number
Pack of 5 non-drip plugs for 0.25 L and 0.6 L cups	5	139.270.210
Pack of filters (200 µm)	4	138.310.300



### GRAVITY PRESSURE CUP FOR M22 GSP

#### PART NUMBER

Description	Material	Capacity (L)	Fitting	Part number
Pressure cup	PeHD (grey)	0.6	M 1/4" BSP	139.270.260

### CUP PAPER FILTER

Disposable filter paper, used to strain the paint before pouring it into the cups.

#### POCHETTE

Description	Quantity	Part number
Pack of paper filter (226 µm)	10	151.399.903

### FUNNELS WITH REMOVABLE STRAINERS FOR CUPS

#### FUNNELS

Description	Internal diameter (mm)	Use	Part number
Funnel with 2 strainers Ø = 50 mm - 210 and 510 µm	105	For cups	057.080.000

#### STRAINERS

Description	Internal diameter (mm)	Size (µ)	Part number
Spare strainer	50	210	057.070.200
Spare element Ø = 50 mm - 510 µm	50	510	057.070.100

### HOSE SLEEVE

#### PART NUMBER

Description	Internal diameter (mm)	Length (m)	Part number
Hoses Sleeve	40	10	129.270.087

### ACCESSORIES AND FILTERS FOR AIRSPRAY GUNS

#### FLUID INLET FILTER





Description	Fittings on gun	Hoses thread	Part number
Fluid Inlet filter with N°6 screen for M22 spray guns (132 µm)	F 3/8" NPS	M 3/8" NPS	129.140.030

#### SEAL PACKS FOR FLUID INLET FILTER

Description	Quantity	Part number
Pack of n°6 screens (132 µm)	10	151.399.902
Pack of seals	10	129.489.902

### ACCESSORIES AND FILTERS FOR AIRSPRAY GUNS (CONTINUED)

#### VARIOUS ACCESSORIES

Image	Description	Fittings on gun	Hoses thread	Part number
	Air inlet swivel fitting	M1/4" G - F 1/4" G		129.020070
	Air inlet quick-disconnect fitting	F 1/4" NPS / M 1/4" NPS		905.030.105
	Gun inlet pressure gauge for HVLP compliance testing	MF 1/4" NPS		150.070.560
	Table stand for gravity-fed spray gun	-		049.221.800
	Wall support for gravity-fed spray gun	-		049.221.900

# A35 HTi spray gun - Stainless Steel



Modular design for High Volume Production with an outstanding finish quality - HTi technology.

### FEATURES

- Excellent atomization quality with outstanding transfer efficiency
- Modular design
- Built-in valve
- Indexed aircap 0 - 90°
- Fluid output adjustment by indexed button
- Stainless steel design

### BENEFITS

- Excellent finish quality, reduced paint costs, cleaner working environment, lower booth maintenance
- Quick service: only 4 bolts to unscrew, no need to remove hoses
- Non air-bleeding gun
- Perfect readjustment of fan pattern
- High precision fluid regulation
- Compatible with water-based materials

### SPECIFICATIONS

Maximum air inlet pressure (bar)	6
Maximum fluid pressure (bar)	6
Trigger air pressure (bar mini)	3
Recommended atomization air pressure (bar)	2 - 2.5
Fluid output (cc/mn)	Upon nozzle (see table)
Weight (g) (gun only)	497
Maximum Fluid Temperature (°C)	50
Transfer efficiency in % (EN 13966-1)	74 (E3 K HVLP) - 72 (EP3)
Air consumption (m³/h)	20 - 30
Wetted parts	Stainless steel - treated stainless steel

### BASE FOR A35 HTI GUNS

Type	Side outputs	Rear outputs
Fluid circulation	Circulation in the base	Circulation in the base ( )
Material (base plate)	Aluminum with stainless steel insert	Aluminum with stainless steel insert
Weight (g)	240	480

### FITTINGS

Power supply	Gun base	Fittings supplied, non fitted
Fluid	F 1/4" NPS	Quick fittings - Ø 6 x 8 hose
Atomization air	F 1/4" NPS	M 1/4 NPS - air hose int Ø 8 mini
Pilot air	F 1/8" NPS	Quick fittings -air hose Ø 4x6

### CONFIGURATION OF THE A35 HTI GUN WITHOUT BASE

Description	Aircap	Nozzle	Part number
A35 HTi without projector, w/o base	-	-	129.300.000

### BASE FOR A35 GUN

Description	Base type	Weight (g)	Wetted parts	Part number
A35 base (circulation in the base (L))	side outlet	240	stainless steel	129.300.050
A35 base (circulation in the base (L))	rear outlet	480		129.300.060

### AIRCAP

#### E3 K HVLP

### CONFIGURATION OF THE A35 HTI GUN FITTED WITH BASE - E3 K HVLP AIRCAP

Description	Projector type	Base type	Nozzles Size (mm)	Fluid output (cc/mn)	Fan width at 20 cm (cm)		Part number
					Minimum	Maximum	
A35 HTi	06 E3 K HVLP	Side outputs	0.6	150	10	25	135.300.112
A35 HTi		Rear outputs					
A35 HTi	07 E3 K HVLP	Side outputs	0.7	200	10	29	135.300.101
A35 HTi		Rear outputs					
A35 HTi	09 E3 K HVLP	Side outputs	0.9	250	10	35	135.300.102
A35 HTi		Rear outputs					
A35 HTi	12 E3 K HVLP	Side outputs	1.2	300	10	38	135.300.103
A35 HTi		Rear outputs					
A35 HTi	15 E3 K HVLP	Side outputs	1.5	350	10	41	135.300.104
A35 HTi		Rear outputs					
A35 HTi	18 E3 K HVLP	Side outputs	1.8	400	10	43	135.300.105
A35 HTi		Rear outputs					





# A35 HTi spray gun - Stainless Steel

## PROJECTORS E3 K HVLP FOR A35 HTI GUNS

Product viscosity in CA4 (s) or centipoises (cps)	Nozzles		Air consumption (m <sup>3</sup> /h)	Fluid flow rate (cc/mn)	Fan width at 20 cm (cm)		Projector		Nozzle part number	Aircap Part number	Needle part number
	Size (mm)				Maximum	Minimum	Type	Part number			
< 20 s	0.6		20 - 30	150	25	10	06 E3 K HVLP	031.300.012	134.130.050	132.300.100	033.300.100
	0.7		20 - 30	200	29	10	07 E3 K HVLP	031.300.001	134.130.100	132.300.100	033.300.100
	0.9		20 - 30	250	35	10	09 E3 K HVLP	031.300.002	134.130.200	132.300.100	033.300.100
20 - 40 s	1.2		20 - 30	300	38	10	12 E3 K HVLP	031.300.003	134.130.300	132.300.100	033.300.100
	1.5		20 - 30	350	41	10	15 E3 K HVLP	031.300.004	134.130.600	132.300.100	033.300.200
	1.8		20 - 30	400	43	10	18 E3 K HVLP	031.300.005	134.130.700	132.300.100	033.300.200

## AIRCAP EP3

### CONFIGURATION OF THE A35 HTI GUN FITTED WITH BASE - EP3 AIRCAP

Description	Projector type	Base type	Nozzles Size (mm)	Fluid output (cc/mn)	Fan width at 20 cm (cm)		Part number
					Minimum	Maximum	
A35 HTi	06 EP3	Side outputs	0.6	150	10	24	135.300.111
A35 HTi		Rear outputs					
A35 HTi	07 EP3	Side outputs	0.7	200	10	25	135.300.106
A35 HTi		Rear outputs					
A35 HTi	09 EP3	Side outputs	0.9	250	10	31	135.300.107
A35 HTi		Rear outputs					
A35 HTi	12 EP3	Side outputs	1.2	300	10	32	135.300.108
A35 HTi		Rear outputs					
A35 HTi	15 EP3	Side outputs	1.5	350	10	34	135.300.109
A 35 HTi		Rear outputs					
A35 HTi	18 EP3	Side outputs	1.8	400	10	38	135.300.110
A 35 HTi		Rear outputs					

## PROJECTORS EP3 FOR A35 HTI GUNS

Product viscosity in CA4 (s) or centipoises (cps)	Nozzles		Air consumption (m <sup>3</sup> /h)	Fluid flow rate (cc/mn)	Fan width at 20 cm (cm)		Projector		Nozzle part number	Aircap Part number	Needle part number
	Size (mm)				Maximum	Minimum	Type	Part number			
< 20 s	0.6		21 - 29	150	24	10	06 EP3	031.300.011	134.130.050	132.300.300	033.300.100
	0.7		21 - 29	200	25	10	07 EP3	031.300.006	134.130.100	132.300.300	033.300.100
	0.9		21 - 29	250	31	10	09 EP3	031.300.007	134.130.200	132.300.300	033.300.100
	1.2		21 - 29	300	32	10	12 EP3	031.300.008	134.130.300	132.300.300	033.300.100
20 - 40 s	1.5		21 - 29	350	34	10	15 EP3	031.300.009	134.130.600	132.300.300	033.300.200
	1.8		21 - 29	400	38	10	18 EP3	031.300.010	134.130.700	132.300.300	033.300.200

## SUPPORTS

Description	Part number
Mounting support Ø 16	049.351.000
Mounting support Ø 12	049.351.700
Adjustable mounting support for Ø12 support	049.351.705
Protective cap (x10)	106.380.818

## KIT

Description	Part number
Remote adjusting fan width kit	029.253.002

# A 35 HPA spray gun - Stainless Steel



Modular design for High Volume Production with an excellent finish quality - HPA technology. Wide fan pattern available.

### FEATURES

### BENEFITS

Excellent atomization quality with outstanding transfer efficiency	Excellent finish quality, reduced paint costs, cleaner working environment, lower booth maintenance
New EN 3L aircap	Unsurpassed wide fan pattern
Modular design	Quick service: only 4 bolts to unscrew, no need to remove hoses
Built-in valve	Non air-bleeding gun
Indexed aircap 0 - 90°	Perfect readjustment of fan pattern
Fluid output adjustment by indexed button	High precision fluid regulation
Stainless steel design	Compatible with water-based materials

### SPECIFICATIONS

Maximum air inlet pressure (bar)	6
Maximum fluid pressure (bar)	6
Trigger air pressure (bar mini)	3
Recommended atomization air pressure (bar)	3 - 5
Fluid output (cc/mn)	Upon nozzle (see table)
Weight (g) (gun only)	497
Maximum Fluid Temperature (°C)	50
Air consumption (m³/h)	33
Wetted parts	Stainless steel - treated stainless steel

### BASE FOR A35 HPA GUNS

Type	Side outputs	Rear outputs
Fluid circulation	Circulation in the base	Circulation in the base ( )
Material (base plate)	Aluminum with stainless steel insert	Aluminum with stainless steel insert
Weight (g)	240	480

### FITTINGS

Power supply	Gun base	Fittings supplied, non fitted
Fluid	F 1/4" NPS	Quick fitting - Ø 6 x 8 hose
Atomization air	F 1/4" NPS	M 1/4" NPS - air hose Ø 7mm int
Pilot air	F 1/8" NPS	Quick fittings - air hose Ø 4x6

### CONFIGURATION OF THE A35 HPA GUN WITHOUT BASE

Description	Aircap	Nozzle	Part number
A35 HPA without projector, w/o base	-	-	129.305.000

### BASE FOR A35 GUN

Description	Base type	Weight (g)	Wetted parts	Part number
A35 base (circulation in the base (L))	side outlet	240	stainless steel	129.300.050
A35 base (circulation in the base (L))	rear outlet	480	stainless steel	129.300.060

# A 35 HPA spray gun - Stainless Steel

## AIRCAP EN 3L

### CONFIGURATION OF THE A35 HPA GUN FITTED WITH BASE

Description	Projector type	Base type	Nozzles Size (mm)	Fluid output (cc/mn)	Fan width at 20 cm (cm)		Part number
					Minimum	Maximum	
A35 HPA	06 EN 3L	Side outputs	0.6	150	10	30	135.305.106
A35 HPA		Rear outputs					
A35 HPA	07 EN 3L	Side outputs	0.7	200	10	31	135.305.101
A35 HPA		Rear outputs					
A35 HPA	09 EN 3L	Side outputs	0.9	250	10	34	135.305.102
A35 HPA		Rear outputs					
A35 HPA	12 EN 3L	Side outputs	1.2	300	10	38	135.305.103
A35 HPA		Rear outputs					
A35 HPA	15 EN 3L	Side outputs	1.5	350	10	39	135.305.104
A35 HPA		Rear outputs					
A35 HPA	18 EN 3L	Side outputs	1.8	400	10	41	135.305.105
A35 HPA		Rear outputs					



### PROJECTORS EN 3L FOR A35 HPA GUNS

Product viscosity in CA4 (s) or centipoises (cps)	Nozzles Size (mm)	Fan width at 20 cm (cm)		Air consumption (m³/h)	Fluid flow rate (cc/mn)	Projector		Nozzle part number	Aircap Part number	Needle part number
		Minimum	Maximum			Type	Part number			
< 20 s	0.6	10	30	24 - 44	150	06 EN 3L	031.305.006	134.130.050	132.305.200	033.300.100
	0.7	10	31	24 - 44	200	07 EN 3L	031.305.001	134.130.100	132.305.200	033.300.100
	0.9	10	34	24 - 44	250	09 EN 3L	031.305.002	134.130.200	132.305.200	033.300.100
	1.2	10	38	24 - 44	300	12 EN 3L	031.305.003	134.130.300	132.305.200	033.300.100
20 - 40 s	1.5	10	39	24 - 44	350	15 EN 3L	031.305.004	134.130.600	132.305.200	033.300.200
	1.8	10	41	24 - 44	400	18 EN 3L	031.305.005	134.130.700	132.305.200	033.300.200

### SUPPORTS

Description	Part number
Mounting support Ø 16	049.351.000
Mounting support Ø 12	049.351.700
Adjustable mounting support for Ø12 support	049.351.705
Protective cap (x10)	106.380.818

### KITS

Description	Part number
Remote adjusting fan width kit	029.253.002

# A25F HPA Flowmax<sup>®</sup> gun - Stainless Steel



Gun shown fitted on base

Flowmax<sup>®</sup> technology: unsurpassed reliability and multi-products use

The A25F Flowmax<sup>®</sup> gun is designed for an intensive use. The sealing of the gun is made with a bellow guaranteeing a high level of reliability. It is recommended for spraying paints, glues, water-based materials and UV products.

## FEATURES

- Excellent atomization quality with outstanding transfer efficiency
- Unique custom-made design of fluid passages at the bellow level
- Adoption of a bellow seal
- Compatible with solvent or water-based materials
- Flushing volume optimized by the bellow technology
- Modular design

## BENEFITS

- Excellent finish quality, reduced paint costs, cleaner working environment, lower booth maintenance
- Optimized flushing and fluid circulation
- Increased reliability
- Universal use meeting most requirements and unique on the market!
- Easy flushing and product savings
- The body of the gun can be easily removed from the base: only 4 bolts needed to release, no need to remove hoses and it maintains optimal position even after servicing
- Dismounting and set-up without hose removal

## SPECIFICATIONS

Maximum air inlet pressure (bar)	6
Maximum fluid pressure (bar)	6
Trigger air pressure (bar mini)	4
Fluid output (cc/mn)	upon nozzle
Weight (g) (gun only)	985
Weight (g) (gun with base plate)	1280
Maximum Fluid Temperature (°C)	50
Air consumption (m <sup>3</sup> /h)	24 (2.5 bar)
Body of the gun	Stainless steel
Wetted parts	Stainless steel - PTFE

## FITTINGS

Power supply	Gun base	Non fitted supplied fitting
Fluid	F 1/4" NPS	Elbow M 1/4" BSP - Ø 6x8 hose
Control Air	F 1/8" NPS	M 1/8" BSP - Ø 4x6 hose
Spraying air	F 1/4" NPS	Straight M 1/4" BSP - M 1/4" NPS for conductive hose Ø8 int min

## CONFIGURATION OF THE A25F HPA GUN WITHOUT BASE

Description	Aircap	Nozzle	Part number
A25F HPA without projector, w/o base	-	-	129.420.000

## BASE FOR A25 FLOWMAX<sup>®</sup> GUN

Description	Base type	Weight (g)	Wetted parts	Part number
A25 F (circulation in the base (L))	side outlet	300	stainless steel	129.420.050

# A25F HPA Flowmax<sup>®</sup> gun - Stainless Steel

## AIRCAP N3C

### A 25F FLOWMAX<sup>®</sup> GUN KIT WITH BASE

Description	Projector type	Max Fluid viscosity in CA 4	Nozzles Size (mm)	Fluid output (cc/mn)	Fan width at 20 cm (cm)		Part number with base
					Minimum	Maximum	
A25F Flowmax <sup>®</sup>	07 N3C	20 - 30s	0.7	200	10	24	151.260.809
A25F Flowmax <sup>®</sup>	09 N3C	20 - 30s	0.9	250	10	26	151.260.810
A25F Flowmax <sup>®</sup>	12 N3C	20 - 30s	1.2	300	10	34	151.260.811



## PART NUMBERS

Product viscosity in CA4 (s) or centipoises (cps)	Description	Tip Size (mm)	Air consumption (m <sup>3</sup> /h)	Fluid flow rate (cc/mn)	Fan width at 20 cm (cm)		Nozzle part number	Aircap		Needle Part number for A25F
					Minimum	Maximum		Type	part number	
< 20 s	07 N 3C	0.7	22	180	6	35	134.021.100	N 3C	132.021.750	033.420.100
	09 N 3C	0.9	22	250	6	35	134.020.100	N3C	132.021.750	033.420.100
	12 N 3C	1.2	22	350	6	35	134.020.200	N3C	132.021.750	033.420.100
	07 N 23C	0.7	22	180	6	35	134.021.100	N 23C	132.021.700	033.420.100
	09 N 23C	0.9	22	250	6	35	134.020.100	N 23C	132.021.700	033.420.100
	12 N 23C	1.2	24	350	6	35	134.020.200	N 23C	132.021.700	033.420.100
	07 LP 23	0.7	22	180	6	35	134.021.100	LP 23	132.060.100	033.420.100
	209 LP 23	0.9	22	250	6	35	134.020.100	LP23	132.060.100	033.420.100
	212 LP 23	1.2	22	350	6	35	134.020.200	LP 23	132.060.100	033.420.100

## EXTENSIONS FOR A25 FLOWMAX<sup>®</sup> GUN

Fan type	Internal diameter (mm)	Length (mm)	Nozzle	Part number
Lateral	8	250	12	075.650.111
Lateral	8	400	12	075.650.311
Circular	20	400	8	075.750.111

## SUPPORTS

Description	Part number
Mounting support Ø 16	049.351.000
Mounting support Ø 12	049.351.700
Adjustable mounting support for Ø12 support	049.351.705
Protective caps (x10)	106.380.818

## KITS

Description	Part number
Seal kit	129.420.901
Remote adjusting fan width kit	029.253.002

# A 29 HTi Spray Gun



Universal gun suitable for a wide range of applications  
 - Recommended for filled materials and small output applications requiring high precision.  
 High finish quality thanks to HTi technology.

### FEATURES

- High opening/closing frequency
- Needle sealing done by a self-adjusting cartridge
- Independent fan and atomization control
- Indexed aircap 0 - 90°
- Fluid output adjustment by indexed button
- Optimized inlet and outlet fluid ports

### BENEFITS

- Intensive production
- Outstanding reliability
- Optimized finish quality and pattern size
- Perfect readjustment of fan pattern
- High precision fluid regulation
- Optimum spraying of high viscosity materials (circulation recommended to keep product homogeneity)

### SPECIFICATIONS

Maximum air inlet pressure (bar)	6
Maximum fluid pressure (bar)	6
Trigger air pressure (bar mini)	3
Fluid output (cc/mn)	upon tip
Weight (g) (gun only)	585
Maximum Fluid Temperature (°C)	50
Air consumption (m³/h)	20 - 30
Fluid circulation	yes
Wetted parts	Stainless steel - Treated stainless steel

### FITTINGS

Power supply	Gun	Hoses
Fluid	M 3/8 NPS	Ø 7 mn Int hose
Atomization air	Quick fittings	Ø 8 x 10 polyamide hose
Pilot air	Quick fittings	Ø 4 x 6 polyamide hose

### CONFIGURATION OF THE A29 HTI GUN WITHOUT BASE

Description	Aircap	Nozzle	Part number
A29 HTi without projector, w/o base	-	-	129.310.000

### A 29 HTi Spray Gun

#### AIRCAP E3 K HVLP

##### CONFIGURATION OF THE A 29 HTI SPRAY GUN FITTED WITH K HVLP AIRCAP

Description	Projector type	Nozzles Size (mm)	Fluid output (cc/mn)	Fan width at 20 cm (cm)		Part number
				Minimum	Maximum	
A 29 HTi	06 E3 K HVLP	0.6	150	10	25	135.310.012
A 29 HTi	07 E3 K HVLP	0.7	200	10	29	135.310.001
A 29 HTi	09 E3 K HVLP	0.9	250	10	35	135.310.002
A 29 HTi	12 E3 K HVLP	1.2	300	10	38	135.310.003
A 29 HTi	15 E3 K HVLP	1.5	350	10	41	135.310.004
A 29 HTi	18 E3 K HVLP	1.8	400	10	43	135.310.005



##### PROJECTORS EP3 K HVLP FOR A29 HTI GUNS

Product viscosity in CA4 (s) or centipoises (cps)	Nozzles Size (mm)	Air consumption (m <sup>3</sup> /h)	Fluid flow rate (cc/mn)	Fan width at 20 cm (cm)		Projector		Nozzle part number	Aircap Part number	Needle part number
				Maximum	Minimum	Type	Part number			
< 20 s	0.6	20 - 30	150	25	10	06 E3 K HVLP	031.300.012	134.130.050	132.300.100	033.300.100
	0.7	20 - 30	200	29	10	07 E3 K HVLP	031.300.001	134.130.100	132.300.100	033.300.100
	0.9	20 - 30	250	35	10	09 E3 K HVLP	031.300.002	134.130.200	132.300.100	033.300.100
	1.2	20 - 30	300	38	10	12 E3 K HVLP	031.300.003	134.130.300	132.300.100	033.300.100
20 - 40 s	1.5	20 - 30	350	41	10	15 E3 K HVLP	031.300.004	134.130.600	132.300.100	033.300.200
	1.8	20 - 30	400	43	10	18 E3 K HVLP	031.300.005	134.130.700	132.300.100	033.300.200



#### AIRCAP EP3

##### CONFIGURATION OF THE A 29 HTI SPRAY GUN FITTED WITH EP3 AIRCAP

Description	Projector type	Nozzles Size (mm)	Fluid output (cc/mn)	Fan width at 20 cm (cm)		Part number
				Minimum	Maximum	
A 29 HTi	06 EP3	0.6	150	10	24	135.310.011
A 29 HTi	07 EP3	0.7	200	10	25	135.310.006
A 29 HTi	09 EP3	0.9	250	10	31	135.310.007
A 29 HTi	12 EP3	1.2	300	10	32	135.310.008
A 29 HTi	15 EP3	1.5	350	10	34	135.310.009
A 29 HTi	18 EP3	1.8	400	10	38	135.310.010



##### PROJECTORS EP3 FOR A29 HTI GUNS

Product viscosity in CA4 (s) or centipoises (cps)	Nozzles Size (mm)	Air consumption (m <sup>3</sup> /h)	Fluid flow rate (cc/mn)	Fan width at 20 cm (cm)		Projector		Nozzle Part number	Aircap Part number	Needle Part number
				Maximum	Minimum	Type	Part number			
< 20 s	0.6	21 - 29	150	24	10	06 EP3	031.300.011	134.130.050	132.300.300	033.300.100
	0.7	21 - 29	200	25	10	07 EP3	031.300.006	134.130.100	132.300.300	033.300.100
	0.9	21 - 29	250	31	10	09 EP3	031.300.007	134.130.200	132.300.300	033.300.100
	1.2	21 - 29	300	32	10	12 EP3	031.300.008	134.130.300	132.300.300	033.300.100
20 - 40 s	1.5	21 - 29	350	34	10	15 EP3	031.300.009	134.130.600	132.300.300	033.300.200
	1.8	21 - 29	400	38	10	18 EP3	031.300.010	134.130.700	132.300.300	033.300.200



##### SUPPORTS AND ACCESSORIES

Description	Part number
Mounting support Ø 16	049.351.000
Adjustable mounting support for Ø12 support	049.351.705
Remote fan width adjusting kit	029.697.003
Protective caps (x10)	106.380.818



Non-modular automatic guns

# A 29 HPA Spray Gun



Universal gun suitable for a wide range of applications  
 - Recommended for filled materials and small output applications requiring high precision.  
 High finish quality thanks to HPA technology.

**FEATURES**

- High opening/closing frequency
- Needle sealing done by a self-adjusting cartridge
- New EN 3L aircap
- Independant fan and atomization control
- Indexed aircap 0 - 90°
- Fluid output adjustment by indexed button
- Optimized inlet and outlet fluid ports

**BENEFITS**

- Intensive production
- Outstanding reliability
- Unsurpassed wide fan pattern
- Optimized finish quality and pattern size
- Perfect readjustment of fan pattern
- High precision fluid regulation
- Optimum spraying of high viscosity materials (circulation recommended to keep product homogeneity)

**SPECIFICATIONS**

Maximum air inlet pressure (bar)	6
Maximum fluid pressure (bar)	6
Trigger air pressure (bar mini)	3
Fluid output (cc/mn)	upon tip
Weight (g) (gun only)	585
Maximum Fluid Temperature (°C)	50
Air consumption (m³/h)	24 - 44
Wetted parts	Aluminum - Stainless steel

**FITTINGS**

Power supply	Gun	Hoses
Fluid	M 3/8 NPS	Ø 7 mm int hose
Atomization air	Quick fittings	Ø 8 x 10 polyamide hose
Pilot air	Quick fittings	Ø 4 x 6 polyamide hose

### A 29 HPA Spray Gun

#### AIRCAP EN 3L

#### CONFIGURATION OF THE A 29 HPA SPRAY GUN

Description	Projector type	Nozzles Size (mm)	Fluid output (cc/mn)	Fan width at 20 cm (cm)		Part number
				Minimum	Maximum	
A 29 HPA	06 EN 3L	0.6	150	10	30	135.315.006
A 29 HPA	07 EN 3L	0.7	200	10	31	135.315.001
A 29 HPA	09 EN 3L	0.9	250	10	34	135.315.002
A 29 HPA	12 EN 3L	1.2	300	10	38	135.315.003
A 29 HPA	15 EN 3L	1.5	350	10	39	135.315.004
A 29 HPA	18 EN 3L	1.8	400	10	41	135.315.005



#### PROJECTORS EN 3L K FOR A29 HPA GUNS

Product viscosity in CA4 (s) or centipoises (cps)	Nozzles Size (mm)	Fluid flow rate (cc/mn)	Air consumption (m³/h)	Fan width at 20 cm (cm)		Projector		Nozzle Part number	Aircap Part number	Needle Part number
				Minimum	Maximum	Type	Part number			
< 20 s	0.6	150	24 - 44	10	30	06 EN 3L	031.305.006	134.130.050	132.305.200	033.300.100
	0.7	200	24 - 44	10	31	07 EN 3L	031.305.001	134.130.100	132.305.200	033.300.100
	0.9	250	24 - 44	10	34	09 EN 3L	031.305.002	134.130.200	132.305.200	033.300.100
	1.2	300	24 - 44	10	38	12 EN 3L	031.305.003	134.130.300	132.305.200	033.300.100
20 - 40 s	1.5	350	24 - 44	10	39	15 EN 3L	031.305.004	134.130.600	132.305.200	033.300.200
	1.8	400	24 - 44	10	41	18 EN 3L	031.305.005	134.130.700	132.305.200	033.300.200



#### SUPPORTS AND ACCESSORIES

Description	Part number
Mounting support Ø 16	049.351.000
Adjustable mounting support for Ø12 support	049.351.705
Protective cap for automatic guns (6)	106.380.856
Remote fan width adjusting kit	029.697.003

# A28 HPA Spray gun - Stainless steel

Automatic gun with Superlife technology (Kremlin patent) for enamels, high solids and solvent-free materials.



### FEATURES

- Patented Superlife™ diaphragm packing (without cartridges)
- Hardened S/S nozzle with removable polyurethan end needle
- Separate fan width and atomization air adjustment
- Optimized inlet and outlet fluid ports

### BENEFITS

- Delivers more than 4 - 5 times a standard package operational life
- Extends the nozzle lifetime - reduced and quick on site maintenance
- Allows for optimum spray pattern and finish quality
- Optimum spraying of high viscosity materials (circulation recommended to keep product homogeneity)

### SPECIFICATIONS

Maximum air inlet pressure (bar)	6
Trigger air pressure (bar mini)	5,5
Maximum fluid pressure (bar)	3
Recommended atomization air pressure (bar)	6
Fluid output (cc/mn)	Upon tip
Weight (g)	1050
Maximum Fluid Temperature (°C)	50
Air consumption (m³/h)	24 @ 4 bar
Body of the gun	Stainless steel
Wetted parts	Stainless steel, treated stainless steel, PTFE, elastomer polyurethan

### FITTINGS

Power supply	Gun	Recommended hoses
Fluid	F 3/8" NPS	Ø 10 mm internal
Trigger air	F 1/8" NPS	Ø 6 or 8 mm upon frequency of use
Spraying air	F 1/4" NPS	Ø 10 mm internal

### AIRCAP

Z 23A

N 23C

### CONFIGURATION OF THE A28 GUN

Designation	Projector type	Use	Nozzle Diameter	Fan width (cm)	Fluid output (cc/mn)	Part number
A 28 HPA	-	Gun w/o projector	-	-	-	129.417.000
A 28 HPA	207 Z 23A	flat pattern	0.7	20-30	100	135.417.001
A 28 HPA	209 Z 23A	flat pattern	0.9	20-30	200	135.417.002
A 28 HPA	212 Z 23A	flat pattern	1.2	20-30	400	135.417.003
A 28 HPA	212 N 23C	flat pattern low pressure	1.2	20-30	400	135.417.004
A 28 HPA	215 N 23C	flat pattern	1.5	25-35	500	135.417.005
A 28 HPA	218 N 23C	flat pattern	1.8	25-35	600	135.417.006



# A28 HPA Spray gun - Stainless steel

## SEAL KITS

Description	Part number
Seal kit	129.417.900
Repair kit	129.417.901

## SUPPORT ET ACCESSOIRES

Description	Part number
Fixing bracket	029.417.011
M5 x 16 Screw	933.011.194
Pin	906.120.089

## AIRCAPS FOR A28

Description	Part number
	
Z 23 A	132.020.550
07 N 23 C	132.021.750
R 23	132.021.300
R 24	132.021.800
R 29	132.021.400
S 23	132.021.900
S 29	132.021.500

## TREATED NOZZLES FOR A28

Description	Part number
	
207T	134.025.050
209T	134.025.100
212T	134.025.200
215T	134.025.300
218T	134.025.400
222T	134.025.600
227T	134.025.700
233T	134.025.800
240T	134.025.900

## SPECIFIC NEEDLE FOR A28

Description	Specific needle for A28 (without needle-end)
Dedicated needle (diaphragm assembly)	129.417.910

## NEEDLE TIP KIT FOR DEDICATED A28 NEEDLE

Description	Part number
Needle tip kit for nozzles sized 7 to 23 (x10)	129.417.005
Needle tip kit for nozzles sized 33 and 40 (x10)	129.417.014
PeHD needle tip kit for nozzles 15 and 18 (x5)	129.417.020

## KITS

Description	Part number
Remote adjusting fan width kit for A26 - A28	029.417.019

# A3 HPA Spray Gun

For delicate work.



### FEATURES

- GL specific projectors mounting
- Optimized inlet and outlet fluid ports

### BENEFITS

- For lines
- Quick color changes and flushing (recommended circulation to maintain fluid homogeneity)

### SPECIFICATIONS

Maximum air inlet pressure (bar)	6
Maximum fluid pressure (bar)	6
Trigger air pressure (bar mini)	3
Recommended atomization air pressure (bar)	3 - 5
Fluid flow rate (cc/mn)	Upon nozzle selected
Weight (g)	320
Maximum Fluid Temperature (°C)	50
Air consumption (m³/h)	10
Body of the gun	Aluminum
Wetted parts	Aluminum, stainless steel, treated stainless steel

### FITTINGS

Power supply	Gun	Fitting
Fluid	F 1/8 NPS	Not supplied
Control air	F 1/8" NPS	Straight M 1/8" BSP - Hose Ø 4 x 6
Pulverization air	F 1/8 NPS	Not supplied

### AIRCAP

PX

GL

### CONFIGURATION

Description	Max Fluid viscosity in CA 4	Projector type	Nozzles Size (mm)	Fan width at 20 cm (cm)		Fluid output (cc/mn)	Part number w/o base plate
				Minimum	Maximum		
A3 HPA	20 s	08 PX	0.8	3	10	200	135.713.014
A3 HPA	20 s	10 PX	1	4	15	300	135.713.011
A3 HPA	20 s	06 PGL	0.6	0.4	2.5	180	135.713.017
A3 HPA	20 s	10 PGL	1	0.4	3	300	135.713.015
A3 HPA	30 s	12 PX	1.2	5	15	450	135.713.012

# A3 HPA Spray Gun

## PROJECTORS FOR A3 HPA GUNS

Product viscosity in CA4 (s) or centipoises (cps)	Nozzles Size (mm)	Fan width at 20 cm (cm)		Fluid flow rate (cc/mn)	Air consumption (m <sup>3</sup> /h)	Description	Projector	Nozzle	Aircap	Needle
		Minimum	Maximum				Part number	Part number	Part number	Part number
< 20 s	0.8	3	10	100	10	08 PX	031.713.014	134.630.400	132.631.100	033.713.400
	1	4	15	120	10	10 PX	031.713.011	134.630.100	132.631.100	033.713.000
	1.2	5	15	150	10	12 PX	031.713.012	134.630.200	132.631.100	033.713.100
	0.6	0.4	2.5	80	10	06 PGL	031.713.017	134.640.300	132.640.100	033.713.500
	1	0.4	3	120	10	10 PGL	031.713.015	134.640.100	132.640.100	033.713.300



## SUPPORT

Description	Part number
Mounting support (Ø16 - length 3.9 inch)	049.351.200

## KITS

Description du kit	Kit part number
A3 indexed needle adjustment kit (precise output adjustment with indexed positioning)	129.713.050

# PMP 150 pump

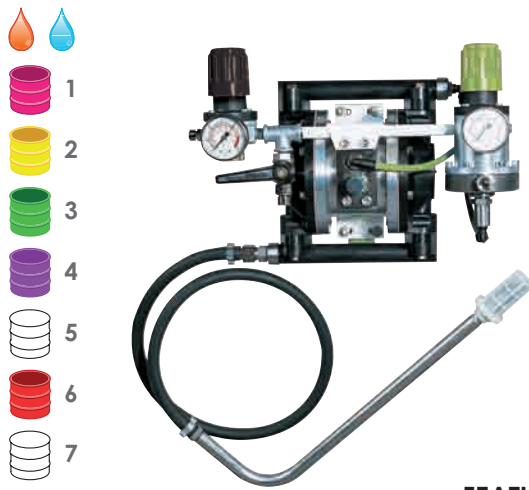

The PMP-150 diaphragm pump is designed for applications requiring a 1: 1 pressure ratio and can be used on some adhesive applications and harsh or high viscosity coatings.

### FEATURES

- Simple design
- Double material diaphragm out of PTFE and nitrile
- Compact design

### BENEFITS

- Easy operation and maintenance
- Compatible with most of solvent or water-based products.
- Quick motor inversion
- Easy to carry

### SPECIFICATIONS

Pressure ratio	1/1
Fluid volume per cycle (cm <sup>3</sup> )	100
Number of cycles per litre of products	10
Air consumption (m <sup>3</sup> /h) at 30 cycles/mn at 4 bar	1.1
Fluid Output at 30 cycles/mn (l/mn)	3
Free flow rate (L/mn)	19
Maximum air inlet pressure (bar)	6
Maximum fluid pressure (bar)	6
Maximum Fluid Temperature (°C)	50
Sound level (dBA)	<70
Weight (kg) - bare pump	5
Wetted parts	PTFE, Polypropylene, Stainless steel
Height (cm) - wall-mounted	24
Width (cm) - wall-mounted pump	36
Depth (cm) - wall-mounted pump	26

### FITTINGS

Fitting	Air inlet (valve)	F 3/8" BSP
	Air outlet (atomization air)	M 1/4" NPS
	Fluid Inlet	M 18 x 125
	Fluid Outlet	M 3/8" NPS

### CONFIGURATION OF THE PMP 150 PUMP

Set-up	Air motor power regulator	Atomization air regulator	Air regulator Fluid pressure	Suction rod	Drain rod	Pump output filter	Part number
Bare pump	-	-	-	-	-	-	144.931.000
Wall mounted	●	●	●	-	-	-	151.759.900
Wall mounted	●	●	●	●	-	-	151.753.000
Wall mounted	●	●	●	●	-	●	151.759.100
Cart mounted	●	●	●	●	-	-	151.754.000
Wall-mounted with stainless steel circulation	-	●	●	●	-	-	151.757.000

# PMP 150 pump

## OPTIONS

Description	Can be fitted on	Part number
Stainless steel circulation kit (to be included: wall bracket ref: 056.100.199)	Wall-mounted and mobile pumps	151.757.010
Motor air supply kit	Bare pump	151.753.050

## SEAL KITS

Description	Part number
PMP motor seal kit	144.931.091
Fluid section seal kit (PTFE)	144.931.092
Fluid section seal kit (EPDM)	144.931.095
Fluid section seal kit (FPM)	144.931.096

## FITTING FOR ELECTROSTATIC INSTALLATION

Description	Part number
Adaptator F 38"NPS/M 1/2" JIC	050.123.306

## CARTS, CUPS AND SUCTION RODS

Description	Part number
2 liters gravity cup kit with bracket	151.758.100
Tripod for PMP 150	051.755.010
2 liters gravity cup kit without bracket	151.662.355
Single Post Cart	051.730.110
Complete wall mounting bracket	051.751.030
Suction rod 18 x 125 fitting - plunger tube length 600mm	049.596.010



## KITS FOR PMP 150 PUMPS

Kit designation	Gun type	Hoses Length (m)	Kit part number
PMP 150 standard wall-mounted	M22 15 EN 3	7.5	151.249.040
PMP 150 standard wall-mounted with stainless steel circulation	M22 15 EN 3	7.5	151.249.050
PMP 150 standard wall mounted	M2209 E 3 K HVLP	7.5	151.249.080
PMP 150 standard wall-mounted with stainless steel circulation	M2209 E 3 K HVLP	7.5	151.249.090



# PMP 150 Pratik pump



The PMP-150 Pratik diaphragm pump is a floor mounted version and is designed for applications requiring a 1:1 pressure ratio and can be used on some adhesive applications and harsh or high viscosity coatings.

### FEATURES

- Simple design
- Double material diaphragm out of PTFE and nitrile
- Rugged design

### BENEFITS

- Easy operation and maintenance
- Compatible with most water-based materials
- Quick motor inversion
- Easy to carry

### SPECIFICATIONS

Pressure ratio	1/1
Fluid volume per cycle (cm <sup>3</sup> )	100
Number of cycles per litre of products	10
Air consumption (m <sup>3</sup> /h) at 30 cycles/mn at 4 bar	1.1
Fluid Output at 30 cycles/mn (l/mn)	3
Free flow rate (L/mn)	19
Maximum air inlet pressure (bar)	6
Maximum fluid pressure (bar)	6
Maximum Fluid Temperature (°C)	50
Sound level (dBA)	<70
Weight (kg) - bare pump	5
Wetted parts	PTFE, Polypropylene, Stainless steel
Height (cm)	87
Width (cm)	39
Depth (cm)	40

### FITTINGS

Fitting	Air inlet (valve)	F 3/8" BSP
	Air outlet (atomization air)	M 1/4" NPS
	Fluid Inlet	M 18 x 125
	Fluid Outlet	M 3/8" NPS

### CONFIGURATION OF THE PMP 150 PRATIK PAINT PUMP

Set-up	Suction rod	Drain rod Ø 6x8	Air motor power regulator	Atomization air regulator	Air regulator Fluid pressure	Pump output filter	Part number
Without cup	●	●	-	●	●	-	151.758.000
Without cup	●	●	●	●	●	-	151.758.300

### SEAL PACKS

Description	Part number
PMP motor seal kit	144.931.091
Fluid section seal kit (PTFE)	144.931.092
Fluid section seal kit (EPDM)	144.931.095
Fluid section seal kit (FPM)	144.931.096

### FITTING FOR ELECTROSTATIC INSTALLATION

Description	Part number
Adaptator F 38"NPS/M 1/2" JIC	050.123.306

### TRIPOD, CUPS AND SUCTION RODS

Description	Part number
Stand for PMP 150	051.755.010
2 liters gravity cup kit with bracket	151.758.100
2 liters gravity cup kit without bracket	151.662.355
Suction rod 18 x 125 fitting - plunger tube length 600mm	049.596.010



### PMP 150 PRATIK PUMP KITS

Kit designation	Gun type	Hoses Length (m)	Cup	Kit part number
PMP 150 Pratik	M22 09 E3 K HVLP	7.5	●	151.249.100
PMP 150 Pratik	M22 15 EN 3	7.5	●	151.249.060

# PMP 150 E Pump

The PMP 150E diaphragm pump is a packing free pump designed with special balls and seats to pump abrasive water-based coatings such as porcelain enamel.

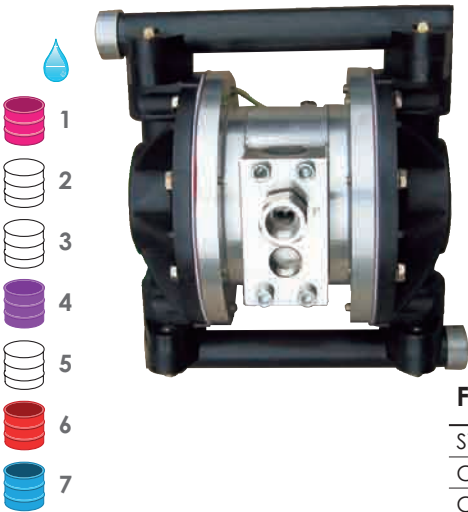

### FEATURES

- Simple and rugged design
- Compact design
- Charged polypropylene diaphragm and polyurethane balls

### BENEFITS

- Compatible with a wide range of materials
- Easy to carry
- Compatible with water-based and enamels

### SPECIFICATIONS

Pressure ratio	1/1
Fluid volume per cycle (cm <sup>3</sup> )	100
Number of cycles per litre of products	10
Air consumption (m <sup>3</sup> /h) at 30 cycles/mn at 4 bar	1.1
Fluid Output at 30 cycles/mn (l/mn)	3
Free flow rate (L/mn)	19
Maximum air inlet pressure (bar)	6
Maximum fluid pressure (bar)	6
Maximum Fluid Temperature (°C)	50
Sound level (dBA)	<70
Weight (kg) - bare pump	5
Diaphragm material	Polyurethane
Wetted parts	Polypropylene, PTFE, polyurethane
Height (cm)	22
Width (cm)	20
Depth (cm)	15

### FITTINGS

Fitting	Air Inlet	F 3/8" BSP
	Fluid Inlet	F 3/8" BSP
	Fluid Outlet	F 3/8" BSP

### CONFIGURATION OF THE PMP 150E PAINT PUMP

Set-up	Suction rod	Drain rod	Atomization air regulator	Air regulator Fluid pressure	Pump output filter	Part number
Bare	-	-	-	-	-	144.932.000

### OPTIONS

Description	Part number
Motor air supply kit	151.753.050

### SEAL PACKS

Description	Part number
PMP motor seal kit	144.931.091
Fluid section seal kit (PTFE)	144.931.092

### CARTS, CUPS AND SUCTION RODS

Description	Part number
Tripod for PMP 150	051.755.010
2 liters gravity cup kit with bracket	151.758.100
2 liters gravity cup kit without bracket	151.662.355
Single Post Cart	051.730.110
Complete wall mounting bracket	051.751.030

# PMP 150 transfer pump

The PMP-150 diaphragm pump is designed for fluid transfer applications.



### FEATURES

- Large suction fluid passage
- Double material diaphragm out of PTFE and nitrile
- Simple design
- Compact design

### BENEFITS

- Possibility of large outputs
- Compatible with most of solvent or water-based products.
- Quick motor inversion
- Easy operation and maintenance
- Easy set-up in the workshop

### SPECIFICATIONS

Pressure ratio	1/1
Fluid volume per cycle (cm <sup>3</sup> )	100
Number of cycles per litre of products	10
Air consumption (m <sup>3</sup> /h) at 30 cycles/mn at 4 bar	1.1
Fluid Output at 30 cycles/mn (l/mn)	3
Free flow rate (L/mn)	19
Maximum air inlet pressure (bar)	6
Maximum fluid pressure (bar)	6
Maximum Fluid Temperature (°C)	50
Sound level (dBA)	<70
Weight (kg) - bare pump	7.4
Wetted parts	PTFE, Polypropylene, Stainless steel
Height (cm)	22
Width (cm)	20
Depth (cm)	15

### FITTINGS

Fitting	Air inlet (valve)	F 3/8" BSP
	Fluid Inlet	F 3/4" NPS
	Fluid Outlet	F 3/8" BSP

### CONFIGURATION OF THE PMP 150 TRANSFER PAINT PUMP

Set-up	Air motor power regulator	Air regulator Fluid pressure	Fluid pressure regulator	Suction rod	Drain rod	Pump output filter	Part number
Bare Transfer PMP 150 pump	●	-	-	-	-	-	151.752.500

### OPTION

Description	Part number
Motor air supply kit	151.753.050

### SEAL KITS

Description	Part number
PMP motor seal kit	144.931.091
Fluid section seal kit (PTFE)	144.931.092

# PDM 01.175 pump

Diaphragm pump specifically designed for circulating and feeding automatic machines.

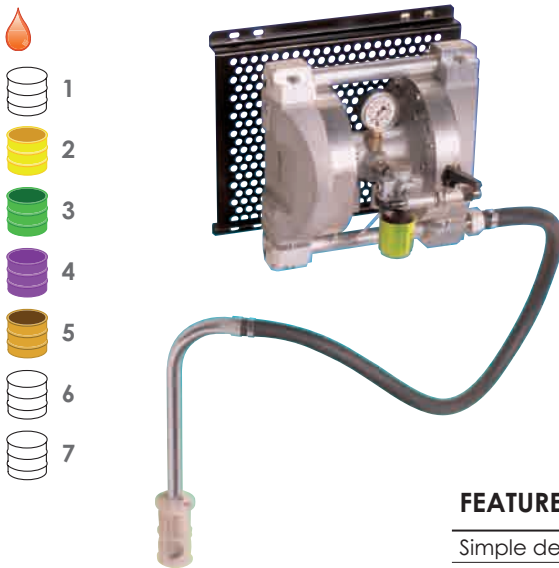

### FEATURES

- Simple design
- Diaphragm made of PTFE
- Compact design

### BENEFITS

- Easy operation and maintenance
- Compatible with most water-based materials
- Easy to carry

### SPECIFICATIONS

Pressure ratio	1/1
Fluid volume per cycle (cm <sup>3</sup> )	350
Number of cycles per litre of products	3
Fluid Output at 30 cycles/mn (l/mn)	10.5
Free flow rate (L/mn)	38
Maximum air inlet pressure (bar)	6
Maximum fluid pressure (bar)	6
Maximum Fluid Temperature (°C)	50
Sound level (dBA)	<70
Weight (kg) - wall-mounted	13
Wetted parts	PTFE, Stainless steel, Aluminum
Height (cm)	29
Width (cm)	24.5
Depth (cm)	31.5

### FITTINGS

Fitting	Air Inlet	F 3/8" BSP
	Fluid Inlet	M 26 x 125
	Fluid Outlet	F 1/2" NPS

### CONFIGURATION OF THE PDM 01.175 PAINT PUMP

Set-up	Suction rod	Drain rod	Atomization air regulator	Air regulator Fluid pressure	Pump output filter	Part number
Bare pump	-	-	-	-	-	144.905.000
Wall mounted pump	●	-	-	●	-	151.656.000

### SUCTION RODS

Description	Part number
Easyflow suction rod Ø25 plunging tube length 600 mm	149.596.150
Easyflow suction rod Ø25 plunging tube length 1000mm (for 200 liters drums)	149.596.160

### SEAL PACKAGES

Description	Part number
Air motor seal kit + air distributor seals	144.931.091
Fluid section seal package	144.900.903
Air distributor seals	144.931.094

# Airspray 02C85 paint pump



The airspray 02C85 piston pump is designed for use with a single or multiple gun system spraying medium viscosity coatings. It can also be used on a heated circulation system.

### FEATURES

- Compact design
- Rugged - High sealing capacity with singlelip seal
- Available in stainless steel version

### BENEFITS

- Easily integrated into a finish workshop
- Compatible with a wide range of materials
- Compatible with water-based materials

### SPECIFICATIONS

Pressure ratio	1.8/1
Fluid volume per cycle (cm <sup>3</sup> )	85
Number of cycles per litre of products	12
Air consumption (m <sup>3</sup> /h) at 30 cycles/mn at 4 bar	2.1
Fluid Output at 30 cycles/mn (l/mn)	2.6
Free flow rate (L/mn)	5.1
Maximum air inlet pressure (bar)	6
Maximum fluid pressure (bar)	10
Maximum Fluid Temperature (°C)	60
Sound level (dBA)	81
Sealing Packings	Upper sealing: GT cartridge with polyethylene packing Lower sealing: Acetal resin seal
Weight (kg) - bare pump	5
Wetted parts	Aluminum, stainless steel
Height (cm)	41
Width (cm) - 2 regulators	28
Depth (cm)	17

### FITTINGS

Fitting	Air inlet (valve)	F 3/8" BSP
	Air outlet (atomization air)	M 1/4" NPS
	Fluid Inlet	M 18x125
	Fluid Outlet	M 3/8" NPS

### CONFIGURATION OF THE AIRSPRAY 02C85 PAINT PUMP

Set-up	Additional regulator	Atomization air regulator	Air regulator Fluid pressure	Suction rod	Drain rod	Pump output filter	Part number
Standard, bare	-	-	-	-	-	-	144.941.000
Standard, wall-mounted	-	●	●	●	-	-	151.760.200
Bare, stainless steel	-	-	-	-	-	-	144.940.000
Wall-mounted, stainless steel	-	●	●	●	-	-	151.761.200
Wall-mounted, stainless steel with 2 air regulators and 1 fluid regulator	●	●	●	●	-	-	151.761.400

### SEAL KITS

Description	Part number
Seal kit for C85 fluid section	144.941.490
Repair kit for C85 fluid section	144.941.495
Seal kit for 340-2 air motor	144.850.150

### FITTING FOR ELECTROSTATIC INSTALLATION

Description	Part number
Adaptator F 38"NPS/M 1/2" JIC	050.123.306

### CARTS AND SUCTION RODS

Description	Part number
Single Post Cart	051.730.110
Suction rod 18 x 125 fitting - plunger tube length 600mm	049.596.010

# Airspray 04C240 paint pump - Stainless steel

For medium viscosity products with 1 or several guns. For circulating and automatic machines.



### FEATURES

- Compact design
- Rugged - High sealing capacity with singlelip seal
- Hot or cold spraying

### BENEFITS

- Easy to carry
- Compatible with a wide range of materials
- To spray a large range of products with the best conditions

### SPECIFICATIONS

Pressure ratio	4/1
Fluid volume per cycle (cm <sup>3</sup> )	240
Number of cycles per litre of products	4
Fluid Output at 30 cycles/mn (l/mn)	7.2
Air Consumption @ 30 CPM at 5 bar	10.3
Free flow rate (L/mn)	14.4
Maximum air inlet pressure (bar)	6
Maximum fluid pressure (bar)	24
Maximum Fluid Temperature (°C)	60
Sound level (dBA)	80
Sealing Packings	Upper sealing PTFE G + Polyfluid Lower sealing PeHD
Weight (kg) - wall-mounted	27
Wetted parts	Stainless steel
Height (cm)	83
Width (cm)	40
Depth (cm)	21

### FITTINGS

Fitting	Air Inlet	F 3/4" BSP
	Fluid Inlet	M 26x125
	Fluid Outlet	M 1/2" JIC

### CONFIGURATION OF THE AIRSPRAY 04C240 PAINT PUMP

Set-up	Suction rod	Drain rod	Atomization air regulator	Air regulator Fluid pressure	Pump output filter	Part number
Bare	-	-	-	-	-	151.792.000
Wall-mounted	-	-	-	●	-	151.792.100
Wall-mounted	●	●	-	●	●	151.792.200
Cart-mounted	●	●	-	●	●	151.792.400

### KITS

Description	Part number
Seal kit	144.970.090
Repair kit	144.970.095
Seal kit for 500-4 air motor	146.260.990
Repair kit for 500-4 air motor	146.260.995

### CARTS AND RODS (SUCTION AND FLUSHING)

Description	Part number
Two Post Cart w/o plate	051.221.000
Two Post Pump Mounting Plate	056.100.199
Easyflow suction rod Ø25 plunging tube length 600 mm	149.596.150
Easyflow suction rod Ø25 plunging tube length 1000mm (for 200 liters drums)	149.596.160
Stainless steel flushing rod F18 x 125	049.596.000

# Airspray 08C240 paint pump - stainless steel



For large production.  
The Turbo air motor is recommended for continued use.

## FEATURES

Large diameter suction rod and high compression ratio  
Stainless steel design  
Simple design , reduced number of spare parts

## BENEFITS

Can be used with a wide range of materials  
Compatible with water-based materials  
Easy maintenance

## FEATURES

Pressure ratio	8/1
Fluid volume per cycle (cm <sup>3</sup> )	240
Number of cycles per litre of products	4
Fluid Output at 30 cycles/mn (l/mn)	7.20
Free flow rate (L/mn)	14.4
Air consumption @ 30 CPM at 5 bar	20.4
Maximum air inlet pressure (bar)	6
Maximum fluid pressure (bar)	48
Maximum Fluid Temperature (°C)	60
Balanced acoustic pressure (dBA)	76
Sealing Packings	Upper sealing PTFE G + Polyfluid Lower sealing PEHD
Weight (kg) - wall-mounted	27
Wetted parts	Stainless steel
Height (cm)	86.4
Width (cm)	35.6
Depth (cm)	25.4

## FITTINGS

Fitting	Air inlet (valve air equipment)	F 3/4 BSP
	Fluid Inlet	M 26 x 125
	Fluid output (filter)	M 1/2 JIC

## CONFIGURATION OF THE AIRSPRAY 08C240 PAINT PUMP - STAINLESS STEEL

Set-up	Suction rod (Ø 25)	Drain rod	Atomization air regulator	Air regulator Fluid pressure	Pump output filter	Part number
Bare	-	-	-	-	-	151.791.000
Wall mounted	-	-	●	●	-	151.791.100
Wall mounted	●	●	●	●	●	151.791.200
2 arm cart mounted	●	●	●	●	●	151.791.400
Turbo wall-mounted	-	-	●	●	-	151.798.100

## KITS

Description	Part number
Seal kit	144.970.090
Repair kit	144.970.095
Seal kit for 1000-4 air motor	146.270.991
Repair kit for 1000-4 air motor	146.270.995

## CARTS AND RODS (SUCTION AND FLUSHING)

Description	Part number
Two Post Cart w/o plate	051.221.000
Two Post Pump Mounting Plate	056.100.199
Easyflow suction rod Ø25 plunging tube length 600 mm	149.596.150
Easyflow suction rod Ø25 plunging tube length 1000mm (for 200 liters drums)	149.596.160
Stainless steel flushing rod F18 x 125	049.596.000
Fluid filter	155.580.300

# PCS 03R440 FLOWMAX® Airspray paint circulating system pump



The 03R440 solves common issues of 24/7 paint pumps. This pump features a bellow technology and a state of the art lubricant circulating system . They are available in wall-mounted versions fitted with GT seals (solvent-based materials) or PU seals (waterborne materials).

### FEATURES

- Performance:**
- Switch air motor technology
  - 2 air motor sizes
  - Large fluid section
- Productivity:**
- Wall-mounted air motor design
  - Divorced fluid section
  - Visual checking of any lubricant color changes
- Sustainability:**
- Use of a Sames Kremlin bellow instead of a lubricant cup
  - Stainless steel and carbide design

### BENEFITS

- Performance:**
- Virtually no maintenance
  - Optimal pressure for each application
  - Ideal for circulating or to handle several guns
- Productivity:**
- Easy dismounting of the fluid section on site
  - Quick and easy maintenance
  - Possibility to schedule maintenance operation
- Sustainability:**
- Extended lifetime up to 10.000.000 cycles and clean paint kitchen environment
  - Optimized wear resistance

### SPECIFICATIONS

Pressure ratio	3/1
Fluid volume per cycle (cm <sup>3</sup> )	440
Number of cycles per litre of products	2.3
Fluid Output at 20 Cycles/mn (l/mn)	8.8
Free flow rate (L/mn)	26.4
Maximum air inlet pressure (bar)	6
Maximum fluid pressure (bar)	18
Maximum Fluid Temperature (°C)	50
Sound level (dBA)	68.4
Sealing packing	Upper Lower
	GT or PU PEHD
Wetted parts	Hard chrome stainless steel, stainless steel, carbide
Weight (kg)	52.8
Height (cm)	133.3
Width (cm)	25.5
Depth (cm)	30.3

### FITTINGS

Fitting	Air inlet	F 3/4" BSP
	Fluid inlet	F 1" NPS
	Fluid outlet	M 3/4" NPS

### CONFIGURATION OF THE PCS 03R440 PAINT PUMP

Mounting	Type of seal	Drain or suction rod	Atomization air regulator	Air regulator Fluid pressure	Pump output filter	Part number
Wall-mounted	GT	-	-	●	-	151.866.100
Wall-mounted	PU	-	-	●	-	151.866.300

### KITS

Description	Part number
GT seal kit	144.990.090
PU seal kit	144.990.130
Maintenance kit (GT seals)	144.990.595
Maintenance kit (PU seals)	144.990.695
Cup kit (including circulation)	144.990.530

### LUBRICANTS

Description	Part number
Lubricant T can (2 liters)	149.990.001
Kit of 3 lubricant T can (2 liters)	151.260.820



# Airspray 04F240 FLOWMAX® paint pump - stainless steel

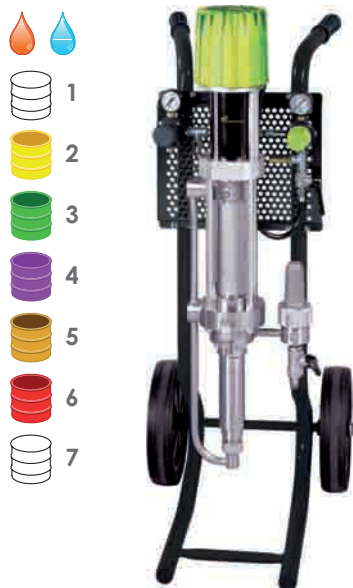

Bellow pump - Flowmax® technology - without packings for automatic machines and circulating

## FEATURES

Sealing done by one large stroke bellow

Ergonomic design of fluid passages

Stainless steel design

Balanced fluid section

Mobile piston seal

## BENEFITS

High reliability No more lubricant cups  
Leak free

Total sealing between pump and its environment, ideal to work with moisture-sensitive catalysts  
Ideal for UV and pre-catalyzed materials

Fluid discharge without retention of a wide range of coating materials

Compatible with water-based materials

Constant fluid output pressure

Excellent suction capacity

## SPECIFICATIONS

Pressure ratio	4/1	
Fluid volume per cycle (cm <sup>3</sup> )	240	
Number of cycles per litre of products	4	
Fluid Output at 30 Cycles/mn (l/mn)	7.2	
Free flow rate (L/mn)	14.4	
Air Consumption @ 30 CPM at 5 bar	10.3	
Maximum air inlet pressure (bar)	6	
Maximum fluid pressure (bar)	24	
Maximum Fluid Temperature (°C)	50	
Sound level (dBA)	< 82	
Sealing packing	Bellows	Polyethylene
	Upper and lower	GT polyethylene
Wetted parts	Stainless steel	
Weight (kg)	27	
Height (cm)	104	
Width (cm)	40	
Depth (cm)	21	

## FITTINGS

Fitting	Air Inlet	F 3/4" BSP
	Fluid Inlet	M 26 x 125
	Fluid Outlet	M 3/8" NPS

## CONFIGURATION OF THE AIRSPRAY 04F240 FLOWMAX® PAINT PUMP

Set-up	Drain rod	Suction rod	Atomization air regulator	Air regulator Fluid pressure	Pump output filter	Part number
Bare	-	-	-	-	-	151.795.000
Wall-mounted	-	-	-	●	-	151.795.100
Wall-mounted	●	●	-	●	●	151.795.200
Cart-mounted	●	●	-	●	●	151.795.400

## CARTS AND RODS (SUCTION AND FLUSHING)

Description	Part number
Two Post Cart w/o plate	051.221.000
Two Post Pump Mounting Plate	056.100.199
Easyflow suction rod Ø25 plunging tube length 600 mm	149.596.150
Easyflow suction rod Ø25 plunging tube length 1000mm (for 200 liters drums)	149.596.160
Stainless steel flushing rod F18 x 125	049.596.000

# PCS 04F440 FLOWMAX® Airspray paint pump - stainless steel



High output, cartridge free bellow pump for circulating and automatic machines.  
The Turbo air motor is recommended for continued use.

### FEATURES

- Sealing done by one large stroke bellow
- Ergonomic design of fluid passages
- Stainless steel design
- Balanced fluid section
- Mobile piston seal

### BENEFITS

- High reliability
- No more lubricant cups
- Leak free
- Total sealing between pump and its environment, ideal to work with moisture-sensitive catalysts
- Ideal for UV and pre-catalyzed materials
- Fluid discharge without retention of a wide range of coating materials
- Compatible with water-based materials
- Constant fluid output pressure
- Excellent suction capacity

### SPECIFICATIONS

Pressure ratio	4/1	
Fluid volume per cycle (cm <sup>3</sup> )	440	
Number of cycles per litre of products	2.3	
Fluid Output at 20 Cycles/mn (l/mn)	8.8	
Free flow rate (L/mn)	26.4	
Air Consumption @ 20 CPM at 5 bar	12.7	
Maximum fluid pressure (bar)	24	
Maximum Fluid Temperature (°C)	50	
Maximum air inlet pressure (bar)	6	
Sound level (dBA)	78	
Sealing packing	Bellows	Polyethylene
	Upper and lower	GT Polyethylene
Wetted parts	Hard chrome stainless steel, stainless steel and carbide	
Weight (kg)	52	
Height (cm)	110	
Width (cm)	38	
Depth (cm)	27.5	

### FITTINGS

Fitting	Air Inlet	F 3/4" BSP
	Fluid Inlet	F 3/4" BSP
	Fluid Outlet	F 3/4" BSP

### CONFIGURATION OF THE PCS 04F440 FLOWMAX® PAINT PUMP

Set-up	Suction rod	Drain rod	Atomization air regulator	Air regulator Fluid pressure	Pump output filter	Part number
Wall-mounted	-	-	-	●	-	151.862.200
Turbo wall-mounted	-	-	-	●	-	151.863.200

### CARTS, FILTER AND RODS (SUCTION AND FLUSHING)

Description	Part number
Two Reinforced Arms w/o mounting plate	051.231.000
Suction rod Ø25 plunging tube length 600 mm	049.597.100
Stainless steel Accumulator equipped filter 3/4"	155.581.400
Stainless steel flushing rod F18 x 125	049.596.000

# PCS 06R440 FLOWMAX® Airspray paint circulating system pump



The 06R440 solves common issues of 24/7 paint pumps. This pump features a bellow technology and a state of the art lubricant circulating system .

They are available in wall-mounted versions fitted with GT seals (solvent-based materials) or PU seals (waterborne materials).

### FEATURES

- Performance:**
- Switch air motor technology
  - 2 air motor sizes
  - Large fluid section
- Productivity:**
- Wall-mounted air motor design
  - Divorced fluid section
  - Visual checking of any lubricant color changes
- Sustainability:**
- Use of a Sames Kremlin bellow instead of a lubricant cup
  - Stainless steel and carbide design

### BENEFITS

- Performance:**
- Virtually no maintenance
  - Optimal pressure for each application
  - Ideal for circulating or to handle several guns
- Productivity:**
- Easy dismounting of the fluid section on site
  - Quick and easy maintenance
  - Possibility to schedule maintenance operation
- Sustainability:**
- Extended lifetime up to 10.000.000 cycles and clean paint kitchen environment
  - Optimized wear resistance

### CARACTÉRISTIQUES

Rapport pression	6/1
Volume produit par cycle (cm³)	440
Nombre de cycles par litre produit	2,3
Débit produit à 20 Cycles / mn (l/mn)	8,8
Débit libre (L/mn)	26,4
Maximum air inlet pressure (bar)	6
Maximum fluid pressure (bar)	36
Maximum fluid temperature (°C)	50
Sound level (dBA)	78
Sealing packings	upper lower
	Joint GT ou joint PU PEHD
wetted parts	Hard chrome stainless steel, stainless steel, carbide
Weight (kg)	55
Height (cm)	133,3
Width (cm)	26,5
Depth (cm)	32,6

### FITTINGS

Fitting	Air inlet	F 3/4" BSP
	Fluid inlet	F 1" NPS
	Fluid outlet	M 3/4" NPS

### CONFIGURATION OF THE PCS 06R440 PAINT PUMP

Mounting	Type of seal	Drain or suction rod	Atomization air regulator	Air regulator Fluid pressure	Pump output filter	Part number
Wall-mounted	GT	-	-	●	-	151.864.100
Wall-mounted	PU	-	-	●	-	151.864.300

### KITS

Description	Part number
GT seal kit	144.990.090
PU seal kit	144.990.130
Maintenance kit (GT seals)	144.990.595
Maintenance kit (PU seals)	144.990.695
Cup kit (including circulation)	144.990.530

Description	Part number
Lubricant T can (2 liters)	149.990.001
Kit of 3 lubricant T can (2 liters)	151.260.820

# Airspray 08F240 FLOWMAX® paint pump - stainless steel

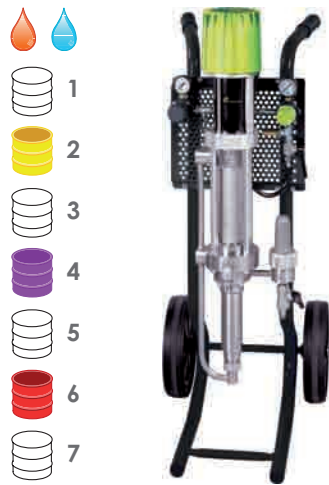

For large production.  
The Turbo air motor is recommended for continued use.

## FEATURES

Sealing done by one large stroke bellow

Ergonomic design of fluid passages

Stainless steel design

Balanced fluid section

Mobile piston seal

## BENEFITS

High reliability  
No more lubricant cups  
Leak free  
Total sealing between pump and its environment, ideal to work with moisture-sensitive catalysts  
Ideal for UV and pre-catalyzed materials

Fluid discharge without retention of a wide range of coating materials

Compatible with water-based materials

Constant fluid output pressure

Excellent suction capacity

## FEATURES

Pressure ratio	08/1
Fluid volume per cycle (cm <sup>3</sup> )	240
Number of cycles per litre of products	4
Fluid Output at 30 cycles/mn (l/mn)	7.2
Free flow rate (L/mn)	14.4
Air Consumption @ 20 CPM at 5 bar	20.4
Maximum air inlet pressure (bar)	6
Maximum fluid pressure (bar)	48
Maximum Fluid Temperature (°C)	50
Sound level (dBA)	76
Sealing packing	Bellows Upper and lower
	Polyethylene GT Polyethylene
Weight (kg) - wall-mounted	32
Wetted parts	Stainless steel
Height (cm)	105
Width (cm)	40
Depth (cm)	27

## FITTINGS

Fitting	Air inlet (valve air equipment)	F 3/4 BSP
	Fluid Inlet	M 26 x 125
	Fluid output (filter)	M 1/2 JIC

## CONFIGURATION OF THE AIRSPRAY 08F240 FLOWMAX® PAINT PUMP - STAINLESS STEEL

Set-up	Suction rod (Ø 25)	Drain rod	Atomization air regulator	Air regulator Fluid pressure	Pump output filter	Part number
Bare	-	-	-	-	-	151.794.000
Wall mounted	-	-	●	●	-	151.794.100
Wall mounted	●	●	●	●	●	151.794.200
2 arm cart mounted	●	●	●	●	●	151.794.400
Turbo wall-mounted	-	-	●	●	-	151.799.100
Turbo wall-mounted	●	●	●	●	●	151.799.200

## KITS

Description	Part number
Seal kit	144.970.490
Repair kit	144.970.495
Seal kit for 1000-4 air motor	146.270.991
Repair kit for 1000-4 air motor	146.270.995

## CARTS AND RODS (SUCTION AND FLUSHING)

Description	Part number
Two Post Cart w/o plate	051.221.000
Two Post Pump Mounting Plate	056.100.199
Easyflow suction rod Ø25 plunging tube length 600 mm	149.596.150
Easyflow suction rod Ø25 plunging tube length 1000mm (for 200 liters drums)	149.596.160
Stainless steel flushing rod F18 x 125	049.596.000
Fluid filter	155.580.300

# PCS 08F440 FLOWMAX® Airspray paint pump - stainless steel



High output, cartridge free bellow pump for circulating and automatic machines.

### FEATURES

- Sealing done by one large stroke bellow
- Ergonomic design of fluid passages
- Stainless steel design
- Balanced fluid section
- Mobile piston seal

### BENEFITS

- High reliability
- No more lubricant cups
- Leak free
- Total sealing between pump and its environment, ideal to work with moisture-sensitive catalysts
- Ideal for UV and pre-catalyzed materials
- Fluid discharge without retention of a wide range of coating materials
- Compatible with water-based materials
- Constant fluid output pressure
- Excellent suction capacity

### SPECIFICATIONS

Pressure ratio	8/1
Fluid volume per cycle (cm <sup>3</sup> )	440
Number of cycles per litre of products	2.3
Fluid Output at 20 Cycles/mn (l/mn)	8.8
Free flow rate (L/mn)	26.4
Air Consumption @ 20 CPM at 5 bar	25.3
Maximum fluid pressure (bar)	48
Maximum Fluid Temperature (°C)	50
Maximum air inlet pressure (bar)	6
Sound level (dBA)	76
Sealing packing	Bellows Upper and lower
	Polyethylene GT ployethylene
Wetted parts	Stainless steel, hard-chrome stainless steel, carbide
Weight (kg)	54
Height (cm)	110
Width (cm)	40
Depth (cm)	27

### FITTINGS

Fitting	Air Inlet	F 3/4" BSP
	Fluid Inlet	F 3/4" BSP
	Fluid Outlet	F 3/4" BSP

### CONFIGURATION OF THE PCS 08F440 FLOWMAX® PAINT PUMP - STAINLESS STEEL

Set-up	Suction rod	Drain rod	Air regulator Fluid pressure	Pump output filter	Part number
Turbo wall mounted	-	-	●	-	151.861.200

### CART, FILTER AND ROD (SUCTION AND FLUSHING)

Description	Part number
Two Reinforced Arms w/o mounting plate	051.231.000
Pump bracket	051.341.206
Suction rod Ø25 plunging tube length 600 mm	049.597.100
Stainless steel Accumulator equipped filter 3/4"	155.581.400
Stainless steel flushing rod F18 x 125	049.596.000
Fluid filter	155.580.300

# Pressure pots



To feed, under pressure, all airspray guns.  
 Conforms to the european legislation regarding the use of equipment under pressure (97/23/CE) (nitrile cover seal in standard).

### SPECIFICATIONS

Type	5 liters	5 liters	10 liters	10 liters	10 liters
Vessel coating	Rilsanised	Rilsanised	Galvanised	Galvanised	Galvanised
Internal diameter (mm)	175	175	250	250	250
Total height (vessel + cover) (mm)	580	580	665	665	665
Vessel height (mm)	322	322	340	340	340
Weight (kg)	9	9	20	20	20
Maximum fluid pressure (bar)	3.8	3.8	3.8	3.8	3.8
Pressure air regulator	1/4"	1/4"	1/4"	1/4"	1/4"
Air regulator Gun	-	-	1/4"	1/4"	1/4"
Removable stainless steel bucket	-	-	-	-	●
Agitator	-	-	-	●	●
Fluid output(s)	Upper	Lower	Upper	Upper	Upper
Part number	052.460.000	053.960.000	152.036.130	152.036.110	152.036.120

### SPECIFICATIONS

Type	30 liters	30 liters	30 liters	52 liters	52 liters	52 liters
Vessel coating	Galvanised	Galvanised	Galvanised	Galvanised	Galvanised	Galvanised
Internal diameter (mm)	320	320	320	400	400	400
Total height (vessel + cover) (mm)	830	830	830	865	865	865
Vessel height (mm)	505	505	505	520	520	520
Weight (kg)	33	33	33	42	42	42
Maximum fluid pressure (bar)	3.8	3.8	3.8	3.8	3.8	3.8
Pressure air regulator	1/4"	1/4"	1/4"	1/4"	1/4"	1/4"
Air Gun regulator	1/4"	1/4"	1/4"	1/2"	1/2"	1/2"
Removable stainless steel bucket	-	-	●	-	-	●
Agitator	-	●	●	-	●	●
Fluid output(s)	Upper	Upper	Upper	Upper (x2)	Upper (x2)	Upper (x2)
Part number	152.126.000	152.126.100	152.126.110	152.220.100	152.220.150	152.220.200

### FITTINGS

Type	5 liters pressure pot	10 to 30 liters pressure pots	50 liters pressure pot
Fitting Air Inlet	M 1/4" NPS	F 3/4" NPS	F 3/4" NPS
Air Outlet	M 1/4" NPS	M 1/4" NPS	(x2) M 1/4" NPS
Fluid Outlet	M 3/8" NPS	M 3/8" NPS	(x2) M 3/8" NPS

### FITTING FOR ELECTROSTATIC INSTALLATION

Description	Part number
Adaptator F 3/8"NPS/M 1/2" JIC	050.123.306

# Stainless steel pressure pots

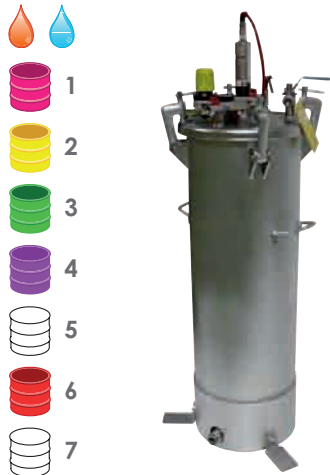

To feed, under pressure, all airspray guns.  
Conforms to the legislation regarding the use of equipment under pressure (97/23/CE) (nitrile cover seal in standard).

## SPECIFICATIONS

Type	15 liters	30 liters	52 liters
Cover material	Stainless steel	Stainless steel	Stainless steel
Vessel material	Stainless steel	Stainless steel	Stainless steel
Internal diameter (mm)	290	290	290
Total height (vessel + cover) (mm)	490	780	1135
Vessel, cover and agitator height (mm)	625	915	1185
Operational Internal height (mm)	180	460	730
Number of clamps	4	4	4
Weight (without/with agitator) (kg)	21/23	23/25	31/33
Number of handle (s)	2	2	2
Valve adjustment (psi)	6	6	6
Maximum fluid pressure (bar)	6	6	6
Maximum Fluid Temperature (°C)	50	50	50
Pressure air regulator	1	1	1
Number of regulators	0	0	0
Number of fluid outputs	2 (Top and Bottom)		
Agitator	According to model		

## FITTINGS

Type		15 liters	30 liters	52 liters
Fitting	Air Inlet	3/8" BSP	3/8" BSP	3/8" BSP
	Fluid outlet	Lower	1" NPT	1" NPT
		Upper	3/8" NPS	3/8" NPS

## PRESSURE POTS PART NUMBERS

Capacity (L)	Pneumatic agitator	Pressure air regulator	Number of fluid outputs		Part number
			Bottom	Top	
15 Liters	-	●	1	1	106.650.15.02
15 Liters	●	●	1	1	106.650.15.03
30 Liters	-	●	1	1	106.650.30.02
30 Liters	●	●	1	1	106.650.30.03
52 Liters	-	●	1	1	106.650.50.02
52 Liters	●	●	1	1	106.650.50.03

## FITTING FOR ELECTROSTATIC INSTALLATION

Description	Part number
Adaptator F 3/8"NPS/M 1/2" JIC	050.123.306



### FUNNELS WITH REMOVABLE STRAINERS FOR PRESSURE POTS

#### FUNNELS

Description	Diameter (mm)	Use	Part number
Large funnels with 2 strainers (510 and 210 μ)	400	10 L - 30 L	057.110.000
Small funnels with 2 strainers (510 and 210 μ)	180	5 L	057.090.000

#### STRAINERS

Description	Diameter (mm)	Size (μ)	Part number
Spare element for large funnel	200	210	057.110.200
	200	510	057.110.100
Spare strainer for small funnel	75	210	057.090.200
	75	510	057.090.100

### ACCESSORIES AND PARTS

#### ACCESSORIES

Description	Capacity (L)	Ø/Dimensions	Part number
Stainless steel spare bucket	10	Ø240 x 265	053.330.200
	30	Ø300 x 420	053.410.200
	50	Ø380 x 420	052.220.015
Nitrile cover seal	5	Ø 175	052.440.001
	10	Ø 250	052.010.002
	30	Ø 320	052.050.008
	50	Ø 400	052.130.006
	5	Ø 175	052.440.002
EPDM cover seal <sup>(1)</sup> - in option for galvanized pressure pots	10	Ø 250	052.010.022
	30	Ø 320	052.050.013
	50	Ø 400	052.130.009
EPDM cover seal <sup>(1)</sup> - in option for stainless steel pressure pots	15-30-52	Ø 290	92009

(1) Recommended with acetone products

#### REGULATORS

Description	Part number
Red knob regulator	016.240.000
2 regulators 1/4" with isolating valves 2 manometers, 1 inlet valve - 1 outlet valve M 1/4" NPS	019.400.000
2 regulators (1/4" + 1/2") with isolating valves 2 manometers, 1 inlet valve - 2 outlet valves M 1/4" NPS	019.390.000

#### MOTORIZED AGITATOR FOR GALVANIZED PRESSURE POTS

Description	Capacity (L)	Part number
10 L	10	052.220.055
30 L	30	052.126.010
52 L	50	052.220.050



# BP 60 HEATERS



Their original design ensures an optimized heat transfer, with no risk of burning the paint in the heater. This equipment will allow you to reduce the viscosity of paints without using solvents. It guarantees an outstanding finish quality, whatever the ambient temperature may be.

This version of the equipment is to be used only for water-based materials.

### FEATURES

- A thermometer is integrated into the command box
- Modular design

### BENEFITS

- No pressure loss when working with high viscosity materials
- Easy maintenance

### SPECIFICATIONS

Thermostatic type	Liquid dilatation and dry contact
Thermal fuse	Cut-out at 121°C
Thermometer	Graduation 0 - 100°C
Temperature range (°C)	15 - 90
Pressure (bar)	250
Weight (kg)	23
Wetted parts	Body and fittings in stainless steel
Room temperature (°C)	40 maxi

### BP HEATER - STAINLESS STEEL VERSION

Stainless steel heater	Voltage / Power		Temperature (°C)	Cable length w/o plug (m)	Fitting		Part number
	Volt	Watt			Inlet	Outlet	
BP60	230	1500	15 - 90	10	M 18×125	M 18×125	056.140.100

# AD 60/61 HEATERS non explosive



Original design ensuring optimum heat transfer with no risk of burning the paint in the heater.

To be used in zone 1 and 2 according to ATEX.

Agreement INERIS 03ATEX 0079X

 II 2 G EEx d IIA T3

### FEATURES

A thermometer is integrated into the command box  
Modular design



### BENEFITS

No pressure loss when working with high viscosity materials  
Easy maintenance



### SPECIFICATIONS

Thermostat type	By fluid extension and dry contact
Thermal fuse	Cut at 121°C
Thermometer	Graduation 0 - 100°C
Temperature range (°C)	15 - 80
Pressure (bar)	240 maxi
Weight (kg)	Aluminum: 15.5 Stainless steel: 25
Wetted parts	Aluminum: aluminum body, galvanized chrome fittings Stainless steel: stainless steel body and fittings
Room temperature (°C)	40 maxi

### AD HEATERS - ALUMINUM VERSION (SOLVENT-BASED MATERIALS)

Aluminum heater	Voltage / Power		Temperature (°C)	Cable length w/o plug (m)	Fitting		Part number
	Volt	Watt			Inlet	Outlet	
AD60 	230	1500	15 - 80	10	M 1/2 JIC	M 1/2 JIC	056.126.000
AD61 	115	1500	15 - 80	5	M 1/2 JIC	M 1/2 JIC	056.126.050

### AD HEATERS - STAINLESS STEEL VERSIONS (SOLVEN OR WATER-BASED MATERIALS)

Stainless steel heater	Voltage / Power		Temperature (°C)	Cable length w/o plug (m)	Fitting		Part number
	Volt	Watt			Inlet	Outlet	
AD60 	230	1500	15 - 80	10	M 1/2 JIC	M 1/2 JIC	056.146.000
AD61 	115	1500	15 - 80	5	M 1/2 JIC	M 1/2 JIC	056.146.050
AD60 	400	1250	15 - 80	5	M 1/2 JIC	M 1/2 JIC	056.146.070

## Accessories for hot circulation



### Y- FITTING - STAINLESS STEEL

Allowing paint circulation on the gun while maintaining ease of use. Remote set-up possible using an additional hose.

#### Y-FITTING PART NUMBERS

Description	Fittings on gun	Hoses thread	Part number
Stainless steel Y-fitting - for air spray guns	F 3/8" NPS	M 1/4" NPS	129.029.915



### CIRCULATION VALVE- BARE - STAINLESS STEEL BODY

Allowing paint circulation at the pump bottom (piston pump)

#### STAINLESS STEEL BODY CIRCULATION VALVE PART NUMBERS

Description	Inlet fitting	Outlet fitting	Purge	Part number
Stainless steel circulation valve	F 1/4" NPS	F 1/4" BSP	F 1/8" BSP	149.220.420

#### STAINLESS STEEL BODY CIRCULATION VALVE - MAINTENANCE KIT PART NUMBERS

Description	Part number
Maintenance kit	049.220.450



### CIRCULATION VALVE - STAINLESS STEEL

Allows you to set the perfect output for circulation.  
Max. fluid pressure: 240 bar.

#### STAINLESS STEEL CIRCULATION VALVES PART NUMBERS

Pump intake	Thread		Back fitting	Flushing valve	Flushing rod M 18 x 125	Part number
	Rod	Rod				
F 26 x 125	M 26 x 125	M 1/2 JIC	●	●	051.314.050	
M 1"G	M 38 x 150	M 3/4 JIC	●	●	051.341.150	

# CTM color change valves

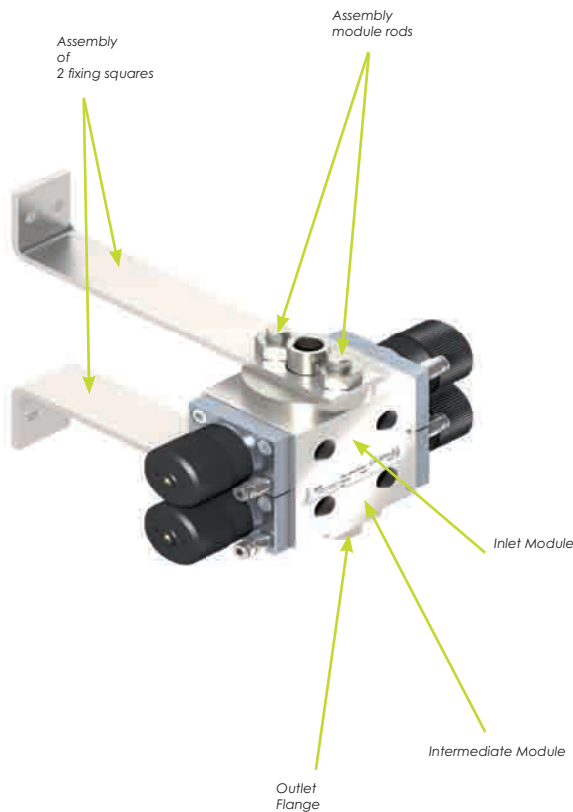

CTM are designed for a rapid color change.

- Two valves per module (the solvent valve should be facing the fluid outlet)
- No dead zone inside CTM reducing flushing time and solvent consumption
- PTFE seals
- Design allows for modular expansion
- Monostable valve normally closed
- Visual Opening detector

For a complete assembly and upon the number of colors:

- Up to 2 colors, you need a 1 module solution made of: 1 inlet module (155.535.100) + 1 outlet flange (155.535.500) + 1 fixing squares kit (155.535.700) + 1 rods kit (155.535.610)
- Up to 4 colors, you need a 2 modules solution made of: 1 inlet module (155.535.100) + 1 outlet flange (155.535.500) + 1 fixing squares kit (155.535.700) + 1 rods kit (155.535.620) + 1 intermediate module (155.535.200)
- Up to 6 colors, you need a 3 modules solution made of: 1 inlet module (155.535.100) + 1 outlet flange (155.535.500) + 1 fixing squares kit (155.535.700) + 1 rods kit (155.535.630) + 2 intermediate module (2 x 155.535.200)
- Up to 8 colours, you need a 4 modules solution made of: 1 inlet module (155.535.100) + 1 outlet flange (155.535.500) + 1 fixing squares kit (155.535.700) + 1 rods kit (155.535.640) + 3 intermediate module (3 x 155.535.200)
- Up to 10 colours, you need a 5 modules solution made of: 1 inlet module (155.535.100) + 1 outlet flange (155.535.500) + 1 fixing squares kit (155.535.700) + 1 rods kit (155.535.650) + 4 intermediate module (4 x 155.535.200)

## CTM VALVE SPECIFICATIONS

Designation	Conventional
Max pressure (bar)	8
Ø of passage (mm)	8
Trigger air	for hose 2.7 x 4
Fluid inlet	F 1/4 NPS
Fluid outlet	F 1/4 NPS

## CONFIGURATION OF CTM VALVES

Description	Part number
Conventional Inlet module (product and solvent inlet)	155.535.100
Conventional Intermediate module (product inlet)	155.535.200
Conventional Outlet flange (product outlet)	155.535.500
Assembly module rods comes with outlet module: <sup>(1)</sup>	Assembly module rod (pack of 2) comes with outlet module:
1 module (1 inlet module + 1 outlet flange)	155.535.610
2 modules (1 inlet module + 1 intermediate module + 1 outlet flange)	155.535.620
3 modules (1 inlet module + 2 intermediate modules + 1 outlet flange)	155.535.630
4 modules (1 inlet module + 3 intermediate modules + 1 outlet flange)	155.535.640
5 modules (1 inlet module + 4 intermediate modules + 1 outlet flange)	155.535.650
Assembly of 2 fixing squares	155.535.700

Each module is equipped with a nut and a washer, the head of the screw must be placed on the outlet flange side. The solvent valve should be facing the fluid outlet.

## Pressure regulator



### PRESSURE REGULATOR - LOW PRESSURE MANUAL CONTROL

Made entirely out of stainless steel, easy to flush.

#### CHARACTERISTICS

Pressure range (bar)	Inlet	40 max.
	Outlet (upon version)	0.5 - 4
Weight (kg)		1.3
Width (cm)		8.5
Height (cm)	Large passages	17
	Small passage	16.5
Wetted parts		Stainless steel, PTFE, carbide

#### SMALL PASSAGE REGULATOR - FITTINGS

Fitting	Fluid Inlet	F 1/4 NPS
	Fluid Outlet	F 1/4 BSP (x2)

#### LARGE PASSAGE REGULATOR - FITTINGS

Fitting	Fluid inlet (w/o adaptor)	M 1/4 BSP
	Fluid Outlet	F 1/4 BSP (x2)

#### CONFIGURATION

Description	Stainless steel ball	Manometer	Part number
Bare pressure regulator PP (small passage)	Ø 5	-	155.610.200
Pressure regulator PP (small passage)	Ø 5	●	155.610.209
Bare pressure regulator GP (large passage) - charged materials	Ø 9	-	155.610.250
Pressure regulator GP (large passage) - charged materials	Ø 9	●	155.610.259
Bracket			155.610.576



Piloted regulator manual drive and integrated pilot

### LOW PRESSURE REGULATOR WITH MANUAL DRIVE AND INTEGRATED PILOT

The regulator with manual drive and integrated pilot is designed for an easy flushing.

#### CHARACTERISTICS

Pressure (bar)	Inlet	10 max
	Outlet	4 max
Width (cm)		20
Height (cm)		8.5
Wetted parts		Stainless steel, PTFE, carbide

#### FITTINGS

Fitting	Fluid Inlet	M 1/4" BSP + (M18x125, M3/8" NPS, M3/8"BSP)
	Fluid Outlet	F 1/4" BSP

#### CONFIGURATION

Description	Weight (kg)	Stainless steel ball	Material	Part number
Low pressure regulator with pressure gauge	1.6	Ø 9	Stainless steel	155.610.060
Bracket				016.200.010

### PRESSURE REGULATOR - PILOTED LOW PRESSURE

Available in stainless steel or non-stick treated versions, excellent flushing. Manual control version available for a very fine regulation and even flow.



Piloted regulator

#### CHARACTERISTICS

Pressure range (bar)	Inlet	Small passage	40 max
		Large passage	6 max
	Outlet	0.5 -4 bar	
	Command air	6 max	
Width (cm)	8.5		
Height (cm)	7.3		
Wetted parts	Stainless steel, PTFE, carbide		

#### SMALL PASSAGE REGULATOR - FITTINGS

Fitting	Fluid Inlet	F 1/4" NPS
	Fluid Inlet (abrasive materials)	F 3/8" NPS
	Fluid Outlet	F 1/4" NPS
	Fluid Outlet (abrasive materials)	F 3/8" NPS
	Air inlet (command)	F 1/8" NPS
	Air inlet (command)(abrasive materials)	1/4"

#### LARGE PASSAGE REGULATOR - FITTINGS

Fitting	Fluid Inlet	M 1/4" BSP + (M18x125, M3/8" NPS, M3/8" BSP)
	Fluid Outlet	F 1/4" BSP
	Air inlet (command)	F 1/8" BSP

#### CONFIGURATION

Description	Weight (kg)	Ball	Material	Part number
Piloted stainless steel pressure regulator	1	Ø 5 (stainless steel)	Stainless steel small passages	155.610.230
Piloted stainless steel pressure regulator for abrasive materials	2.6	Ø 5 (carbide)	Stainless steel small passages	155.610.520
Piloted stainless steel pressure regulator	1	Ø 9 (stainless steel)	Stainless steel large passages	155.610.050
Bracket				016.610.576

#### CONFIGURATION NON STICK COATING

Description	Stainless steel ball	Material	Part number
Piloted non-stick coating pressure regulator	Ø 11	Stainless steel large passages	055.370.100
Bracket			016.200.010



Piloted regulator non-stick coating



**PRESSURE REGULATOR - BACK LOW PRESSURE**

Available in stainless steel manual control version.

**CHARACTERISTICS**

Pressure (bar) - regulated materials	4 max
Weight (kg)	1.3
Width (cm)	8.5
Height (cm)	16.8
Wetted parts	Stainless steel, PTFE, carbide

**FITTINGS**

Fitting	Fluid Inlet	F 1/4" BSP
	Fluid Outlet	M 1/4" BSP + (M18x125, M3/8"NPS, M 3/8"BSP)

**CONFIGURATION**

Description	Part number
Back pressure regulator	155.610.100
Options:	-
- Wall bracket	016.200.010
- Pressure gauge: stainless MF 1/4 elbow	050.470.101
Stainless steel tube	050.081.701
Stainless steel shroud	050.470.301
Gauge	910.011.402

**INLINE FILTER**

**CONFIGURATION**

Description	Part number
Low pressure filter compatible with M22 and PMP150	129.020.060
Screen number 6 (x10)	151.399.902
Seals (x10)	149.949.901

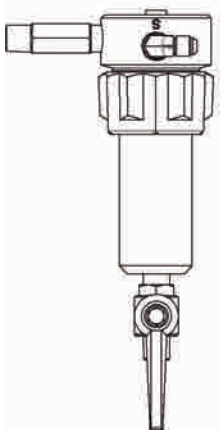

**FILTER 60 BAR**

**CONFIGURATION**

Description	Part number
Stainless steel filter fitting length 70 mm (MM 3/8" NPT)	055.580.301
Wall-mounted bracket and screws for 3/8", 3/4" and 1" filter with 9 digits part numbers	155.190.105

**EQUIPPED FILTER**

Description	Maximum fluid pressure (bar)	Stainless steel screen for filter	Thread			Part number
			Inlet	Outlet	Drain	
3/8" stainless steel filter-medium pressure	60	6	F 3/8" NPT (x1)	F 3/8" NPT (x2)	F 3/8" G cuve (x1)	155.580.500
Stainless steel Filter 3/8"-Low pressure	60	6	M 1/4" NPT	M 1/2" JIC <sup>(1)</sup>	M 18x125	155.580.510

(1) See adaptation fitting F1/2 JIC/M3/8 NPS reference 050.123.533



**STRAINERS FOR SUCTION RODS**

**STRAINERS CONFIGURATION**

Pump	Height (mm)	External diameter (mm)	Material	Filtration size		Part number
				Micron	Mesh	
PMP150 / 02.75	60	40	Polyamide	300	50	051.531.600
PDM 01.75 / 04.120 / 04.120F	40	48	Inox	1000	15	149.596.152
04.220 F	112	66	Polyamide	1000	15	149.591.400

**SCREEN AND CARTRIDGES FOR FLUID FILTER**

**SCREEN CONFIGURATION (FILTRATION SURFACE 65 CM<sup>2</sup>)**

Filter number	Filtration size		Nozzle size	Part number
	Micron	Mesh		
1	40	325	3	000.161.101
2	74	200	4	000.161.102
3	90	170	4	000.161.103
4	100	140	4	000.161.104
6	168	85	6	000.161.106
8	210	70	09 & 14	000.161.108
12	280	55	20	000.161.112
15	360	45	30 & 45	000.161.115
20	510	30	< 68	000.161.020
30	750	20	< 68	000.161.030



# Cyclix™ agitators for 20-40-200 l drums



This elevator-agitator for 20-40 to 200l drums features a double-effect jack for a fast lift of a stainless steel cover fitted for a quick material drum change. The cover is equipped with a motorized agitator fitted with blades for low viscosity materials and a full stainless steel rod.

The elevator is coming on a large fixing plate which makes it very stable and easy to install in paint kitchens, existing installations or an essential component of new installations.

### FEATURES

Stainless steel (agitator cover, suction and drain rods)  
 Adjustable suction rod height  
 Suction and return tubes  
 Double effect jack with 3 positions command lever: up, stop, down  
 The agitator cannot work during elevator movements

### BENEFITS

Compatibility with all materials  
 No product loss  
 Suitable for recirculating  
 Important flexibility  
 Security

### CHARACTERISTICS

Capacity (L)	20 - 40	200	
Motor type	Pneumatic	Pneumatic	
Reductor type	-	Gear train	
Rotation speed (rpm)	60 - 300	5 - 90	
Motor torque	Nm	2.2	34

### CYCLIX™ PART NUMBERS FOR 20 - 40 L DRUMS

Description	Elevator height (mm)	Agitator rod length (mm)	Paddle diameter (mm)	Cover diameter (mm)	Part number
Elevator for 20 -40 l drums	1024 (min) - 1500 (max)	-	-	-	151.081.000
Agitator for 20 -40 l drums	-	400	134	-	154.261.700
Cover for 20 -40 l drums	-	-	-	400	154.261.600
Suction/exhaust kit	-	-	-	-	154.261.800

### CYCLIX™ PART NUMBERS FOR 200 L DRUMS

Description	Elevator height (mm)	Agitator rod length (mm)	Paddle diameter (mm)	Cover diameter (mm)	Part number
Elevator for 200 l drums	1510 (mini) - 2410 (maxi)	-	-	-	151.091.000
Agitator for 200 l drums	-	800	370	-	154.261.300
Cover for 200 l drums	-	-	-	635	154.261.200
Suction/exhaust kit	-	-	-	-	154.261.400

### RECOMMENDED ACCESSORIES

Description	Part number
1/4" air lubricator + support	154.261.997
Exhaust assembly with oil recovery (length 1 m)	154.261.996
Air feeding kit	154.261.930
Drum roller unit for 200 litres drum	151.098.100
Slotted paddle for thick materials	154.261.952
HP 150 2 liters lubricant can	149.990.017

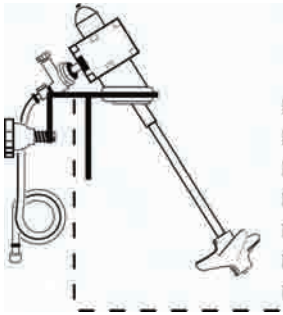

**AGITATORS FOR EDGE PAIL MOUNTING**

Agitator for barrel edge mounting. Minimum barrell height of 300 mm

**AGITATORS**

Description	Part number
Bare agitator	051.332.610
Agitator with 25 cm hose	051.332.600
Agitator with 5 m hose	049.220.710
System for barrel mounting	049.220.720



**AGITATORS ON STAINLESS STEEL COVER**

Agitator: For drums diameter between 295 and 325 mm

**AGITATORS**

Description	Part number
Agitator for Ø325 cover	903.290.101

**STRAINER FOR CYCLIX™ SUCTION RODS**

**STRAINER FOR CYCLIX™ SUCTION RODS**

Description	Part number
Strainer for cyclix™ suction rods	154.261.940

**PRODUCT HOSES FOR AIRSPRAY SPRAYING**

A hose carrying paint must be able to resist most solvents.

For conventional spraying, Kremlin offers two types of hose:

- Flexible blue paint rubber with internal sheath in PEBD for most solvents
- White polyamide: when the paint is thicker, to reduce pressure losses.



**HOSES CONFIGURATION**

Designation	Part number				
	Rubber/ PEBD internal sheath			Polyamide <sup>(1)</sup>	
Internal diameter mm	6.35 (1/4")	9.52 (3/8")	16	6.35 (1/4")	9.52 (3/8")
Maximum pressure: bar	10		7	10	
Color	blue			white	
Temperature	up to 60 °C				
P.N. without fitting 5 m	050.362.004	050.361.005	050.363.005	050.370.805	050.370.905
P.N. without fitting 15m	050.362.003	050.361.004	050.363.004	050.370.804	050.370.904
P.N. without fitting 25m	050.362.001	050.361.001	050.363.001	050.370.801	050.370.901
P.N. without fitting 100m	050.362.002	050.361.002	050.363.003	050.370.803	050.370.903
SK collar	906.311.236	906.311.226	906.311.207	-	-
<b>lengths with fittings part number</b>					
A and B fitting (free nut)	1/4" NPS	3/8" NPS	-	1/4" NPS	3/8" NPS
0.55 m		050.361.103			
1 m	050.362.451 <sup>(2)</sup>	-	050.361.108	-	-
2 m	-	-	-	-	050.370.504
5 m	050.362.101	050.362.603	050.361.105	050.370.301	050.370.201
7.5 m	050.362.104	050.362.601	050.361.102	-	-
10 m	050.362.102	050.362.602	050.361.106	050.370.302	050.370.202

(1) Recommended for glues

(2) Elbow fitting

**PRODUCT HOSES FOR SUCTION ROD**

**HOSE FOR SUCTION ROD**

Designation	Part number		
	Ø 9.5 mm	Ø 19 mm	Ø 25 mm
5 m cut	050.361.005	050.366.051	050.367.001
15 m cut	050.361.004	050.366.052	-
25 m cut	050.361.001	050.366.053	050.367.003
Grooved conical fitting	050.140.517	050.140.545	050.140.543
Nickeled nut fitting	050.271.303	050.271.502	049.595.306
SK collar	906.311.234	906.311.207	906.311.204

### AIR HOSES

Used in majority of the applications, allows the equipment (gun and pump) to have the same potential, ATEX certified.



#### HOSES CONFIGURATION

Available in 3 diameters:	Small	Medium	Big
<b>Technical Characteristics</b>			
Material	TPU*	TPU*	Nitrile
Color	Black	Black	Black
Internal Diameter (mm)	6.5	8	10
External Diameter (mm)	10.5	12	16
Conductor	Yes	Yes	Yes
Weight (grams per meter)	61	75	130
Max operating pressure in bar	14	14	10
Operating temperature in °C	-40 to 80	-40 to 80	up to 60
<b>Hoses with fittings</b>			
Fittings	1/4" NPS		3/8" NPS
0.6m	050382105	050389109	-
1.2m	050382102	050389107	-
2m	050382111	050389110	-
5m	050382109	050389101	050381101
7.5m	050382114	050389103	-
10m	050382110	050389102	050381102
12.5m	050382106	-	-
15m	050382116	-	-
20m	-	050389108	-
30m	-	050389106	-
<b>Hoses without fittings</b>			
25m	050382001	050389001	050381001
152m	050382006	050389005	-
250m	050382007	050389006	-
<b>Fittings</b>			
Hose crimp ring	906311237	906311238	906311226
KIT STRAIGHT CONN. + NUT 1/4 NPS	050231705	050231707	050231702
fitting = 1 crimp ring + 1 kit			
Manual Crimper (Diameters 5 to 22)	906311202		

\* TPU : Thermoplastic Polyurethane

### POLYAMIDE OR POLYURETHANE AIR HOSES

Non-conductive hoses to clip on automatic guns or any other device.

#### POLYAMIDE OR POLYURETHANE AIR HOSES

Conductive	No						
Max operating pressure	10 Bar						
Temperature	Up to 60°C						
Length	25m						
Material	Polyamide				Polyurethane		
Color	translucent		black		blue		black
Diameter (internal/external) in mm	2.7 x 4	4x6	6x8	8x10	4x6	6x8	8x12
<b>Reference</b>	<b>050372102</b>	<b>050372103</b>	<b>050372104</b>	<b>050372125</b>	<b>050372213</b>	<b>050372214</b>	<b>050372226</b>

### HOSE SLEEVE

Hose sleeve adds a protection to the hose for a longer life

#### HOSE SLEEVE

product hole (mm)	length (m)	Reference
40	10	129270087

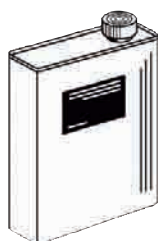
**LUBRICANTS AND GREASES FOR PUMPS**
**LUBRICANT FOR PUMP PACKINGS**

Description	Part number
<b>Lubricants for pump fittings</b>	
T lubricant (125 ml) can for solvent-based paints	149.990.020
Kit of 3 T lubricant cans (2L each)	151.260.820
P lubricant can (2L each) (PU products)	149.990.022
Kit of 3 P lubricant cans (2L each) (PU products)	151.260.823
<b>Grease</b>	
Vaseline 1 kg	560.440.002
Box of 450 g PTFE grease	560.440.001
Box of 1kg grease special air motor seals	560.440.001
Tube 20g grease special air motor seals	560.440.005
Teflon® grease tube 10 ml	560.440.105
Box of grease (450g)	560.420.005
<b>Glue</b>	
Sealing glue tube	554.180.015
Low strength anaerobic adhesive tube	554.180.010

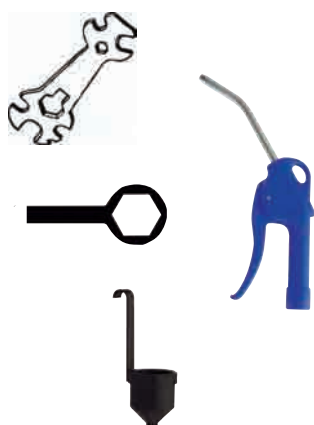
**MISCELLANEOUS**
**PART NUMBERS**

Description	Part number
M22/Xcite™ gun wrench	049.030.042
Large size brush	906.300.101
Small size brush	906.300.102
Wrench for product filters	049.030.018
Large blow gun	129.371.000
Viscosity cup N° 4 CA4	049.221.400
Thickness gauge from 25 to 2000µ	000.790.020
Adhesive-roller with SAMES KREMLIN logo (75mm x 100m)	571.141.003

**TACK WIPE PADS**

Silicon-free, antisitatic, soft, non toxic, non-drying dust absorbers

**PART NUMBERS**

Description	Quantity	Part number
Box of 10 (white-coloured, for finish)	24	149.990.023
Box of 10 (unbleached for primer)	24	149.990.024

# RC 600 full visor mask

Maximum protection for excellent working conditions, optimal health protection with low operating costs. The RC 600 is compliant with the latest european norms.



RC600 visor mask

### FEATURES

- Complete assembly with protection screen
- Light and ergonomic
- Low airflow alarm
- Adjustable head and front protection
- Easy disposable screen protectors

### BENEFITS

- Complete protection of the operator face and eyes (against isocyanates especially)
- Reduced fatigue and excellent working conditions for increased productivity
- Constant operator protection
- Suitable for everyone and user-friendly
- Easy maintenance

### CONFIGURATION OF THE RC 600 FULL-VISOR MASK

Description	Part number
RC 600 full-visor mask complete	143.400.000
Belt supply air hose assembly	143.400.002

### ACCESSORIES

Description	Quantity	Part number
RC 600 full-visor mask alone (without regulator)	1	143.400.007
Screen protector	50	143.400.006

# RC 756 respirators

Lightweight, comfortable respirators efficient for each type of paint and compliant with the latest european norms (Respirator: EN 140, Filters: EN 14393)



### FEATURES

- Respirator body made of silicone
- Equipped with large inlet and outlet valves
- Double fixing straps
- Double filters
- Three high performance filters type available (solvented, water-based or multi with isocyanate materials)

### BENEFITS

- Hypoallergenic and high comfort
- Easy breathing
- Comfortable
- Performance (large diameter), visibility and high level of safety
- For an optimal protection whatever the type of paint used

### CONFIGURATION OF THE RC 756 RESPIRATOR

Description	Part number
RC 756 respirator	143.380.100
RC 756 respirator for SOLVENT-BASED PAINTS - A1 filters	143.380.200
RC 756 respirator for WATER-BASED PAINTS - A1B1P3 filters	143.380.300
RC 756 respirator for PLURAL COMPONENT PAINTS - ISOCYANATES - A1B1E1K1P3 filters	143.380.400

### FILTERS & PRE-FILTERS

Description	Type	Quantity	Part number
Filters for solvented paints	A1	10	143.380.210
Filters for water-based paints	A1B1P3	5	143.380.310
Filters for plural-components-isocyanates	A1B1E1K1P3	5	143.380.410
Pre-filters for A1 filters	-	25	143.380.110

### ACCESSORIES

Description	Quantity	Part number
Attach strap	1	143.380.120
Spare inlet/outlet valves	3	143.380.130



### PROTECTIVE OVERALLS

Protects the operator. Comfortable to wear, giving protection for dust or plush.

- Conforms to European Standards
- Made in non-woven fabric, they come with elasticated wrists and wide trouser legs to protect footwear

#### PART NUMBERS

Description	Size	Quantity	Part number
Overalls Size S for 5 sets	S	5	564.504.001
Overalls Size M for 5 sets	M	5	564.504.002
Overalls Size L for 5 sets	L	5	564.504.003
Overalls Size XL for 5 sets	XL	5	564.504.004
Overalls Size XXL for 5 sets	XXL	5	564.504.005



### PROTECTIVE HOOD

Protects the head and hair

- Non-woven, light and lets the skin breathe
- Conforms to European Standards

#### PART NUMBERS

Description	Quantity	Part number
Protective hood	5	043.250.001





# PLURAL COMPONENT PUMPS AND MACHINES

# PU 2125 F pump

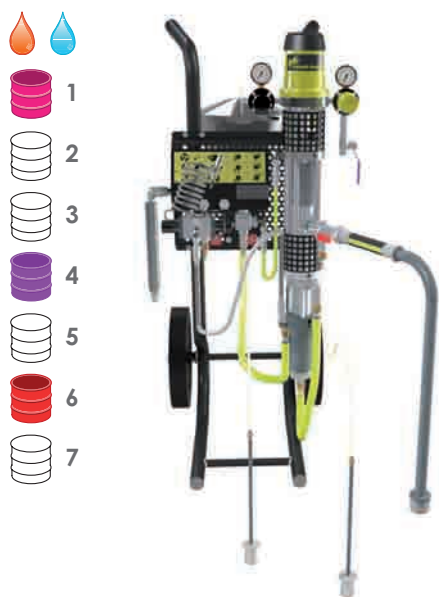

The Flowmax® technology, a Sames Kremlin patented SuperLife™ bellow design, ensures a perfect mixing accuracy thanks to the total sealing without packings. Fixed ratio: the economical and easy solution while benefitting from the HTi, HPA and HTV spraying.

PU 2125 F are tested and comes complete ready for use.

PU 2125 F are available in 5 mixing ratio versions: 1/1, 2/1, 3/1, 4/1 or 5/1.

### FEATURES

Sealing done by a FLOWMAX® bellow on the catalyst side

Comes with mixer, mix manifold, air feeding assembly, suction rod for base and flushing solvent, 6 L catalyst gravity tank

Semi-automatic manifold with synoptic

Catalyst re-circulation

Stainless steel fluid sections (base and catalyst) - in standard

Cart-mounted pump

### BENEFITS

High reliability  
No more lubricant cups  
Leak free  
Total sealing between pump and its environment, ideal to work with moisture-sensitive catalysts  
Ideal for UV and pre-catalyzed materials

Ready to use pump

Safe operation  
User-friendly

Quick color change and flushing without catalyst loss

Chemical compatibility w/o any risk of corrosion with water-based materials

Easy positioning in the working area (various working areas)

### SPECIFICATIONS

Mixing ratio (upon version)	1/1 - 2/1 - 3/1 - 4/1 - 5/1
Pressure ratio	0.9 à 1.6/1
Max Fluid viscosity in CA 4	180 s
Maximum air inlet pressure (bar)	6
Balanced acoustic pressure (dBA)	80
Weight (kg)	50
Wetted parts	Stainless steel, polyethylene, treated steel Catalyst fluid section: 304 stainless steel Bellow: PTFE

### DOSING RATIO

Description	Volumic dosing ratio	Fluid Output at 20 Cycles/mn (l/mn)	Pressure ratio	Fluid pressure (upon air motor pressure)	
				4 bar	6 bar
PU 2125 F 1/1	1/1	3.5	0.9/1	3.6	5.4
PU 2125 F 2/1	2/1	2.6	1.2/1	4.8	7.2
PU 2125 F 3/1	3/1	2.4	1.4/1	5.6	8.4
PU 2125 F 4/1	4/1	2.2	1.5/1	6	9
PU 2125 F 5/1	5/1	2.1	1.6/1	6.4	9.6

# PU 2125 F pump

## FITTINGS

Fitting	Air inlet (valve)	F 3/8" BSP
	Air outlet (atomization air)	M 1/4" NPS
	Fluid Outlet	M 1/2" JIC

## PU 2125F PART NUMBERS

Description	Part number
PU 2125F pump cart-mounted - Dosing ratio 1/1	151.586.100
PU 2125F pump cart-mounted - Dosing ratio 2/1	151.586.110
PU 2125F pump cart-mounted - Dosing ratio 3/1	151.586.120
PU 2125F pump cart-mounted - Dosing ratio 4/1	151.586.130
PU 2125F pump cart-mounted - Dosing ratio 5/1	151.586.140

## Electronic dosing

# PU 3000 2I

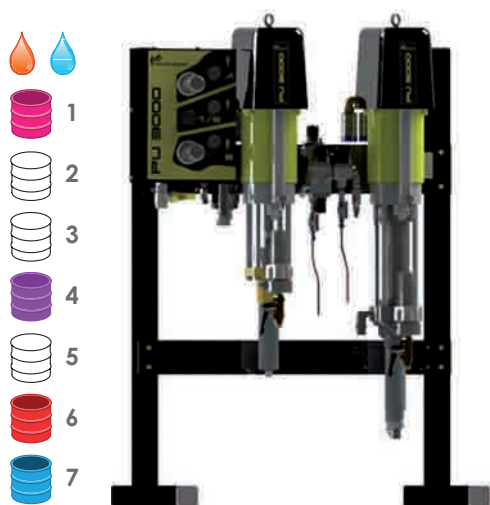

PU 3000 2I

The PU 3000, innovative economical and patented solution, combines electronic control and mechanical metering, ready to use.

The user-friendly control box allows the operator to intuitively learn how to operate the machine.

**PATENTED** : The innovative pump change-over - FREE PULSE ELECTRONIC technology (FPE) - features a perfectly constant output and a +/- 1% metering accuracy for an outstanding finish and operator peace of mind. Electronic dosing constantly monitors the actual material consumption of products and calculates the VOC.

The machine can be installed in an ATEX 1 or 2 zone to be in close proximity to the operator. The control box must be installed in safe zone (ATEX Directive). PU 3000 2I is available in HTI / HPA / HTV versions.



### FEATURES

### BENEFITS

Plug & Spray	Quick start-up
Sames Kremlin patent: Free Pulse Electronic Control (FPE)	Constant fluid flowrate
Innovative control system of pump change-over	Unsurpassed +/- 1% mixing accuracy and +/- 1% repeatability
Direct injection in the high performance static mixer	Perfect mixing
Recording of fluid consumptions and VOC Possibility to print records	Fluid and solvent consumptions stored in memory
Automatic component management: base, catalyst and solvent	User friendly
Automatic flushing and material generation	User-friendly and easy programming for the operator
User-friendly control panel	
Preventive maintenance alarm	Safe operation
Continuous ratio checking and alarm	
Low level drum alarm	
Ratio check kit in standart with 2 liters test tube	Visual control of mixing accuracy
Filter and drain assembly in standart	No product loss
Sealing done by a FLOWMAX® bellow on the catalyst side	High reliability
	Total sealing between pump and its environment, ideal to work with moisture-sensitive catalysts
Wide range of ratio from 5 to 160% Suitable for HTI / HPA / HTV spraying technologies	Suitable for use on a wide range of markets
Very low flow rate from 10cc	

### SPECIFICATIONS

Electrical Power	115/230V - 75W
Maximum air inlet pressure (bar)	6
Fluid viscosity	30 - 8000 cps
Mixing accuracy	+/- 1%
Mixed fluid output	PU 3000 2I: 10cc at 2000 cc / min
Mixing ratio	1/1 - 20/1 (100% - 5%)
Wetted parts	Stainless Steel and PEHD

# PU 3000 2l

## TECHNICAL CHARACTERISTICS

Description	Pressure ratio	Air motor type	Maximum fluid pressure (bar)
PU 3000 - Airspray versions	1/1 . 7/1	1500	0/6 - 0/40

## PU 3000 DIMENSIONS

Description	Height (cm)	Depth (cm)	Width (cm)
AIRSPRAY versions	PU 3000 2l: 130	70	86
Control Box	28.6	14.3	36.7

## FITTING

Fitting	Air inlet (valve)	F 3/4" BSP
	Air Outlet	F 1/4" BSP
	Fluid Outlet	F 3/4 JIC

## PU 3000 2L PART NUMBERS

Description	Part number
PU 3000 - HTi, HPA and HTV versions - 100cc - 2l	155.680.140

## PU 3000 OPTION PART NUMBERS

Description	Part number
Spray booth glass mounting kit	155.660.340

## PU 3000 FLUSHING PUMPS PART NUMBERS

Description	Suction rod	Purge rod	Air regulator fluid pressure	Filter	Part number
02-C85 flushing pump - PU 3000	● (Ø 16)	-	-	-	155.680.170

# CYCLOMIX™ Micro and Micro+ PH



Supplied without pumps or guns to be ordered separately  
Designed to supply one gun only

User-friendly precise and control mixing of 2 components materials. With CYCLOMIX™ Micro, the mixing process is mastered and guaranteed. All technical fluid and application characteristics are fully configurable. Once programmed, CYCLOMIX™ Micro will automatically handle all parameters. The programming is user-friendly and quick, with data in-putting by magnetic signal. Flushing and maintenance are very simple. In addition, the system can be controlled from inside the booth. CYCLOMIX™ Micro+ allows the flushing of the catalyst fluid passages especially for water-based materials. For acid catalyst it exists specific references for a CYCLOMIX™ Micro+ PH. Safe zone installation where applicable (Directive ATEX).

## FEATURES

## BENEFITS

Automatic component management: base, catalyst and solvent	Dosing +/- 1% and repeatability +/- 0.5%
Automatic flushing and material generation	Quick start-up. Minimal material and solvent wastage.
Adjustable flushing volume Several flushing sequence available: only Base side; Base side then Catalyst; Catalyst side then Base side	Solvent savings and environmental protection
Continuous ratio checking and alarm	The paint applied on parts always conforms to specifications
User-friendly control panel	User-friendly and easy programming for the operator
Stainless steel design	To handle a wide range of materials
Recording of fluid consumptions and VOC with the possibility to print records (with RS 232 option)	Fluid and solvent consumptions stored in memory
Possibility to monitor the Cyclomix™ Micro from the spray booth (with the glass kit option)	Ergonomy of the working station
Design of the mixing plate	Easy maintenance and spare parts standardization

## SPECIFICATIONS

Electrical Power	115 / 230V - 75W
Trigger air pressure (bar mini)	4
Product pressure (bar)	2 - 175
Weight (kg)	25
Wetted parts	Stainless steel and PEHD 316L stainless steel on PH version catalyst side
Mixing ratio	single component and 0,6/1 to 20/1
Mixing accuracy	1%
Maximum number of gun to be fitted	1
Mixed fluid output	100 - 2000 cm³/mn
Fluid viscosity	30 - 5000 cps
height (cm)	17.3 (command cabinet) - 40 (dosing unit)
Width (cm)	36.6 (command cabinet) - 40.7 (dosing unit)
Depth (cm)	11.1 (command cabinet) - 30 (dosing unit)

## FITTINGS

Description	Fitting
Electrical supply: bornier and stuffing box	
Air supply	F 1/4" BSP
Air outlet	F 1/4" BSP
Fluid supply	M 1/2" JIC
Fluid outlet	M 1/2" JIC

## CYCLOMIX™ MICRO, MICRO+ AND MICRO+ PH PART NUMBERS

Description	Catalyst fluid passage flushing	Number of bases	Number of catalysts	Part number
CYCLOMIX™ Micro	-	1	1	155.660.900
CYCLOMIX™ Micro	-	3	1	155.660.930
CYCLOMIX™ Micro+	●	1	1	155.660.911
CYCLOMIX™ Micro+	●	3	1	155.660.933
CYCLOMIX™ Micro+ PH (without mixer - see options)	●	1	1	155.660.951
CYCLOMIX™ Micro+ PH	●	3	1	155.660.953

## OPTIONS CYCLOMIX™ MICRO, MICRO+ AND MICRO+ PH PART NUMBERS

Description	Part number
Mixing assembly for Cyclomix® Micro+ PH	155.660.955
RS 232 connection kit for printer	155.660.935
Spray booth glass mounting kit	155.660.340
5m extension cable between control cabinet and mixing panel	901.250.216

# CYCLOMIX™ Multi and Multi PH



Supplied without pumps or guns to be ordered separately  
Designed to supply one gun only

CYCLOMIX™ electronic dosing to handle several colors: CYCLOMIX™ Multi can handle up to 7 different bases and 3 catalysts.

Modular design CYCLOMIX™ Multi can be positioned in zone 1 or 2 (Directive ATEX). The control cabinet must be installed in safe zone (ATEX Directive).

Programming and use are user-friendly by means of a large touch screen.

For acid catalyst it exists specific references for a CYCLOMIX™ Multi PH.

## FEATURES

## BENEFITS

Automatic component management: base, catalyst and solvent	Dosing +/- 1% and repeatability +/- 0.5%
Automatic mix material fill	Quick start-up. Minimal material and solvent wastage.
Adaptable programming for each color	Ideal application for each color
Several flushing modes: production cycle, extended production stops, solvent-based materials	Perfect compatibility with production conditions evolutions
Fast mixing ratio accuracy by beakers batch mode	Visual control of mixing accuracy To easily get small quantities of mixed materials for touch-up works
Autowash system	Off-production gun automatic monitoring
Multilingual display and integrated instruction manual	User-friendly and easy programming for the operator
Stainless steel design	Compatible with water-based materials
Numerical interface	Quick link with an on-line automate
Integrated spraying air management	Comfort and safety during color and solvent fill
Pneumatic emergency flushing	Perfect flushing in case of power supply cut-off
Design of the mixing plate	Easy maintenance and spare parts standardization
Robotic interface	Connection with an on-line automate

## SPECIFICATIONS

Electrical Power	115 / 230 V - 75 W
Trigger air pressure (bar mini)	4
Product pressure (bar)	2 - 200 bar
Weight (kg)	70
Wetted parts	Stainless steel and PeHD
Mixing ratio	0.6/1 to 20/1 (160% to 5%)
Mixing accuracy	+/- 1%
Maximum number of gun to be fitted	1
Solvent flowrate (m³/h)	100 - 2000 cm³/mn
Mixed fluid output	100 - 2000 cm³/mn
Fluid viscosity	30 - 5000 cps
height (cm)	60 (control cabinet) - 77 (mixing unit)
Width (cm)	60 (control cabinet) - 60 (mixing unit)
Depth (cm)	40 (control cabinet) - 77 (mixing unit)

## FITTINGS

Description	Fitting
Air supply	F 1/4" BSP
Air outlet	F 1/4" BSP
Fluid supply	M 1/2" JIC
Fluid outlet	F 1/4" BSP

## CYCLOMIX™ MULTI PART NUMBERS

Description	Number of bases	Number of catalysts	Part number
CYCLOMIX™ Multi	3	1	155.660.813
CYCLOMIX™ Multi	5	1	155.660.815
CYCLOMIX™ Multi	7	1	155.660.817
CYCLOMIX™ Multi	3	2	155.660.823
CYCLOMIX™ Multi	5	2	155.660.825
CYCLOMIX™ Multi	3	3	155.660.833
CYCLOMIX™ Multi PH	3	1	155.660.513
CYCLOMIX™ Multi PH	5	1	155.660.515
CYCLOMIX™ Multi PH	7	1	155.660.517

## OPTION PART NUMBER CYCLOMIX™ MULTI

Description	Part number
Autowash	155.660.300



# CYCLOMIX™ Expert

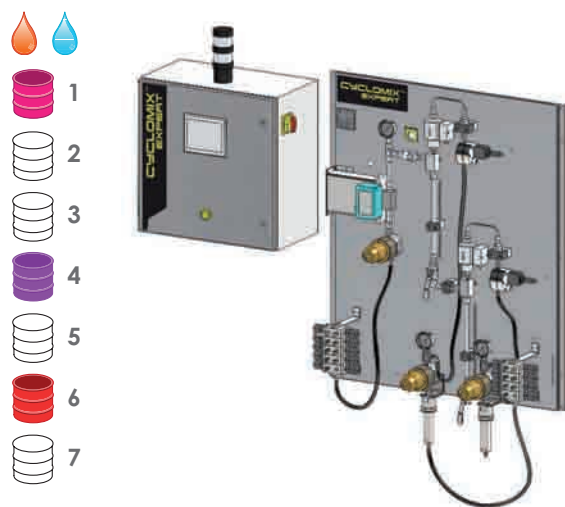

Supplied without pumps or guns to be ordered separately

Cyclomix™ EXPERT, industrial and evolutive solution, innovative, guarantees total quality of production .

CYCLOMIX™ Expert can manage a total up to 24 components (bases, catalysts, flushing solvents). It can handle mono, bi or tri-component materials

The innovative dosing process - ultra fast injection valve - offers unequalled mixing quality and dosing accuracy. The machine can handle 2 working stations at the same time. The machine programming by means of a color screen with ratio/tolerance data assist management - up to 15 languages - has been designed to bring comfort and easiness in the case of product or parameters modifications. The electronic technology brings total monitoring and follow-up of real material consumptions, VOC with recording possibility to ensure tracability.

CYCLOMIX™ Expert can be fitted with different flowmeters technologies (ex: mass flowmeter for difficult paint to handle or water-based materials). The possibility to use Flowmax® technology - developed by Sames Kremlin - bellows instead of traditional packings on the catalyst side brings total reliability for moisture-sensitive isocyanates catalysts.

CYCLOMIX™ Expert is available in Airspray versions to meet all market needs, in manual or automatic spraying.

The fluid manifold can be set-up in the spraying area in order to reduce the paint hoses length. Safe zone location (ATEX Directive) for the control cabinet.

Options are available to upgrade the machine depending on each customer configuration.

- Remote color screen control cabinet

Accessible directly from the working station (spray booth), it allows the operator to manage production, color changes, flushing...

- Automatic Flush box

Located in the spraying area closed to the painter, it enables the painter to be hands free while system is flushing.

# CYCLOMIX™ Expert

FEATURES	BENEFITS
Automatic component management up to 24 components in 1, 2, 3 components and solvent	Innumerable possibilities Flexibility when changing materials
Real time display of instant real ratio and flowrate	Continuous process control
No pre-mixing chamber: optimized fluid passages w/o retention zones	Perfect flushing Prevent fluid waste
Stainless steel design	Compatible with water-based materials
Frequency configuration before flushing at the end of potlife	Mixed material and solvent savings Safe operation
Emergency pneumatic manual flushing	Perfect flushing in case of power supply cut-off
Batch mode	To easily get small quantities of mixed materials for touch-up works
Adaptable programming for each color	Ideal application for each color
3 data access level upon each operator	Safety use
Assisted data and tolerance product manufacturer specification entry	Quick and easy data entry eliminating any errors
Color man/machine interface	User friendly
Standard monitoring of 2 guns (2 priming - 2 flushing)	Possibility to manage 2 workstations simultaneously (1 or 2 guns or both)
Ratio check	Safe operation Full operator safety
6 different flushing sequences (air-solvent es standard) Volume or time flushing Multiples solvent choice for each recipe	Solvent consumption optimization upon recipe Optimized flushing
Magnetic injection volume adjustment - electro magnetic valves	Mixing optimization upon ratios Increase of injection frequency
USB data storage Batch number management	Production Follow-up optimization
Various Product mesurement technology: mass or gear	Handles a large range of materials

## SPECIFICATIONS

Voltage (V)	115 - 230
Number of fluid inlets	24
Trigger air pressure (bar mini)	4
Operating pressure (bar)	5 - 200
Mixing ratio (in standard)	0.6/1 at 30/1
Mixing accuracy	+/- 1%
Mixed fluid output	50 - 6000 cm <sup>3</sup> /mn
Fluid viscosity	30 - 5000 cps
Wetted parts	Stainless steel and PeHD (option 316L)
Width (cm)	100 (3K) - 89 (2K)
Height (cm)	119 (3K) - 91 (2K)
Weight (kg)	48 (2K) - 68 (3K)

## CONTROL BOX CHARACTERISTICS

Width (cm)	60
Height (cm)	60
Depth (cm)	40
Weight (kg)	25

## CYCLOMIX™ EXPERT PART NUMBER

Description	Part number
CYCLOMIX™ Expert	Please consult us



# FITTINGS AND AIR TREATMENT

**MALE TO MALE CONNECTION PMAX: 20 BAR**

Max Pressure (20 bar)

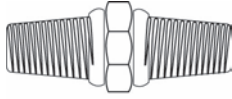

**METRICAL FITTINGS - 20 BAR**

Male/Male	M 14 x 125	M 18 x 125
M 14 x 125		050.102.133 050.102.142 <sup>(1)</sup>
M 18 x 125	050.102.133 050.102.142 <sup>(1)</sup>	050.102.102

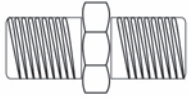

**METRICAL ADAPTORS TOWARDS BSP - 20 BAR**

Male/Male	M 14 x 125	M 18 x 125	M 26 x 125
G 1/8" (BSP) (5 x 10)	050.102.412		
G 1/4" (BSP) (8 x 13)	050.102.405 050.102.441 <sup>(1)</sup>	050.102.408 050.102.444 <sup>(1)</sup>	
G 3/8" (BSP) (12 x 17)	050.102.410	050.102.411 050.102.436 <sup>(1)</sup>	
G 1/2" (BSP) (15 x 21)	050.102.513	050.102.406 050.102.418 <sup>(1)</sup>	050.102.402 050.102.437 <sup>(1)</sup>
G 3/4" (BSP) (20 x 27)		050.102.429	050.102.407

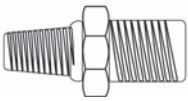

**METRICAL ADAPTORS TOWARDS NPT - 20 BAR**

Male/Male	M 26 x 125
1/2" NPT	050.102.507

**MALE TO MALE CONNECTION PMAX: 60 BAR**

**FITTINGS BSP (GAZ) - 60 BAR**

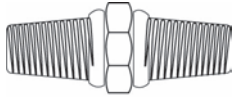

Male/Male	G 1/8" (5 x 10)	G 1/4" (8 x 13)	G 3/8" (12 x 17)	G 1/2" (15 x 21)	G 3/4" (20 x 27)
G 1/8" (5 x 10)		906.314.207 <sup>(1)</sup>			
G 1/4" (8 x 13)	906.314.207 <sup>(1)</sup>	050.102.213 906.314.203 <sup>(1)</sup>	904.523.003 906.314.204 <sup>(1)</sup>	050.102.211	
G 3/8" (12 x 17)		904.523.003 906.314.204 <sup>(1)</sup>	050.102.214 906.314.202 <sup>(1)</sup>	904.523.006 906.314.205 <sup>(1)</sup>	
G 1/2" (15 x 21)		050.102.211 050.102.647 <sup>(1)</sup>	904.523.006 906.314.205 <sup>(1)</sup>	050.102.212	904.523.012
G 3/4" (20 x 27)				904.523.012	050.102.215

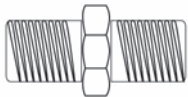

**FITTINGS NPT - 60 BAR**

Male/Male	1/4" NPT	3/8" NPT
1/4" NPT		905.083.201
3/8" NPT	905.083.201	

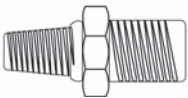

**FITTINGS NPS - 60 BAR**

Male/Male	1/4" NPS	3/8" NPS
1/4" NPS	050.102.630	050.102.632
3/8" NPS	050.102.632	050.102.631 050.102.652 <sup>(1)</sup>

**ADAPTOR NPS TOWARDS BSP (GAZ) - 60 BAR**

Male/Male	1/4" NPS	3/8" NPS
G 1/4" BSP	050.102.624 050.102.644 <sup>(1)</sup>	050.102.646 <sup>(1)</sup>
G 3/8" BSP	050.102.627 050.102.647 <sup>(1)</sup>	050.102.628 050.102.648 <sup>(1)</sup>
G 1/2" BSP	050.102.633	050.102.629 050.102.649 <sup>(1)</sup>
G 3/4" BSP		050.102.654 <sup>(1)</sup>

(1) Stainless steel fittings

**FEMALE TO FEMALE CONNECTION**

**P<sub>MAX</sub>: 60 BAR**

**FITTINGS BSP (GAZ) - 60 BAR**



Female/Female	G 1/4" (BSP)
G 1/4" (BSP) (8 x 13)	904.593.002
G 3/8" (BSP) (12 x 17)	904.503.003

**ADAPTOR BSP (GAZ) TOWARDS METRIC - 20 BAR**

Female/Female	G 1/4" (BSP)
M 14 x 125	050.221.401

**T FEMALE BSP (GAZ) - 60 BAR**

Description	Part number
Fittings 3 x G 1/4" (BSP) (8 x 13)	904.303.002
Fittings 3 x G 3/8" (BSP) (12 x 17)	904.303.003
Fittings 3 x G 1/2" (BSP) (15 x 21)	904.303.004
Fittings 3 x G 3/4" (BSP) (20 x 27)	904.303.006

**T FEMALE NPT - 60 BAR**

Description	Part number
Fittings 3 x 1/4" NPT	905.083.301

**MALE TO FEMALE CONNECTION**

**P<sub>MAX</sub>: 20 - 60 BAR**

**ADAPTOR NPS TOWARDS JIC, NPS AND METRIC - 20 BAR**

Male/Female	1/4" NPS	3/8" NPS
1/2" JIC	150.123.305 <sup>(1)</sup>	050.103.537 <sup>(1)</sup>
1/4" NPS	-	050.103.534 <sup>(1)</sup>
M 14 x 125	-	050.103.523 <sup>(1)</sup>

<sup>(1)</sup> Stainless steel fittings

**FITTINGS BSP (GAZ) - 60 BAR**

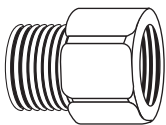

Male/Female	G 1/4" (8 x 13)	G 3/8" (12 x 17)	G 3/4" (20 x 27)
G 1/4" (8 x 13)	050.123.205	904.533.003	-
G 3/8" (12 x 17)	904.513.003	-	-
G 1/2" (15 x 21)	904.513.005	-	904.533.009
G 3/4" (20 x 27)	904.513.011	904.513.012	-
G 1" (26 x 34)	-	-	904.513.012

**FITTINGS METRIC - 20 BAR**

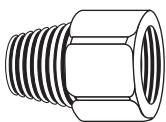

Male/Female	M 14 x 125	M 18 x 125	M 26 x 125
M 14 x 125	-	050.123.109	-
M 18 x 125	050.123.101	-	050.123.110
M 26 x 125	-	050.123.106	-

**ADAPTOR METRIC TOWARDS NPS - 20 BAR**

Male/Female	M 14 x 125	M 18 x 125
1/4" NPS	050.123.535	050.123.526
3/8" NPS	-	050.123.610

**ADAPTOR JIC TOWARDS METRIC - 20 BAR**

Male/Female	M 14 x 125	M 18 x 125
1/2" JIC	050.230.619	050.230.620

**ADAPTOR JIC TOWARDS NPS AND METRIC - 20 BAR**

Male/Female	1/2" JIC
1/4" NPS	050.123.304
3/8" NPS	050.123.533
M 18 x 125	050.123.521

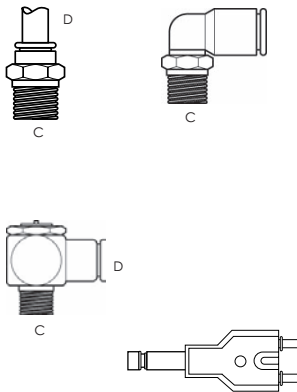

**QUICK FITTINGS FOR SMALL DIAMETER SPECIAL AIR HOSES**  
**CONFIGURATION FITTINGS**

C	D	Straight	Right angle 90°	T- piece
G 1/8" (5 x 10) BSP	4	905.120.907	905.120.926	-
G 1/8" (5 x 10) BSP	8	-	905.120.934	-
G 1/4" (8 x 13) BSP	4	-	905.120.927	-
G 1/4" (8 x 13) BSP	6	905.120.965	905.120.905	-
G 1/4" (8 x 13) BSP	8	905.120.904	905.120.912	905.120.920
6 x 8 hose T	T for hose 4 x 6	2,7 x 4 Hose T- piece	4 x 6/2,7 x 4 Reduction T- piece	
905.120.915	905.120.903	905.120.957	905.120.928	

**ISO 6150 QUICK-FIT FITTINGS (MAXIMUM PRESSURE: 10 BAR)**

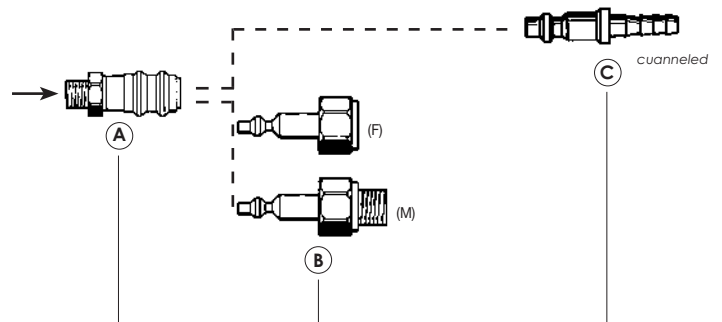

**QUICK FITTINGS**

Type	Complete assembly A and B	Part A with built-in chutter valve	Part B	Part C for rubber hose Ø 7	Part C for rubber hose Ø 10
Ø5 (14x125)	905.030.405	905.030.102	905.030.406 (F)	905.030.203	905.030.204
Ø5 (1/4" BSP)	-	-	905.030.804 (M)	-	-
Ø5 (1/4" BSP)	-	-	905.030.803 (F)	-	-
Ø5 (1/4" NPS)	905.030.105	905.030.104	905.030.106 (F)	-	-
Holding collar	-	-	-	906.311.224	906.311.226

**COMPLETE QUICK DISCONNECT 1/4" NPS FOR AIR HOSE**

Description	Part number
Air inlet quick-disconnect fitting	905.030.105

**QUICK FITTINGS FOR Ø 8 HOSE**

Type	Part A with on/off press button for hose Ø 8	Part C for hose Ø 8
Ø 5	905.030.801	905.030.802

**FITTINGS FOR LOW PRESSURE POLYAMIDE HOSES**

**FITTINGS CONFIGURATION**

Thread size	Material	Hoses Inter. Diameter (mm)	Part number
M 3/8" NPS	Nickel plated brass	6.35 - 1/4	050.231.350
M 1/4" NPS	Nickel plated brass	6.35 - 1/4	050.231.450
M 3/8" NPS	Nickel plated brass	9.52 - 3/8	905.140.103

## CRIMP FITTINGS FOR LOW PRESSURE AIR HOSES FITTINGS CONFIGURATION



Material	Thread size	Hoses Inter. Diameter (mm)	Part number	Collar
<b>Straight fittings</b>				
Nickel plated brass	1/4" NPS	7	050.231.705	906.311.224
Nickel plated brass	1/4" NPS	8	050.231.707	906.311.224
Nickel plated brass	1/4" NPS	10	050.231.702	906.311.226
Nickel plated brass	3/8" NPS	7	050.231.716	906.311.224
Nickel plated brass	3/8" NPS	10	050.231.706	906.311.226
Nickel plated brass	3/8" NPS	16	050.231.701	906.311.232
Stainless steel	M 14 x 125	5	050.230.610	906.311.208
Nickel plated brass	M 14 x 125	10	050.230.602	906.311.226
Nickel plated brass	M 18 x 125	7	050.230.616	906.311.224
Stainless steel	M 18 x 125	10	050.230.614	906.311.226
Nickel plated brass	M 18 x 125	10	050.230.606	906.311.226
Nickel plated brass	M 18 x 125	16	050.230.601	906.311.232
Nickel plated brass	M 26 x 125	16	050.230.603	906.311.232
<b>Elbow fittings</b>				
Nickel plated brass	M 18 x 125	10	050.250.202	906.311.226
<b>Junction fittings without thread</b>				
Nickel plated brass	-	7	050.190.403	906.311.224
Nickel plated brass	-	10	050.190.401	906.311.226

## PLUGS PMAX: 20 - 60 BAR PLUGS CONFIGURATION

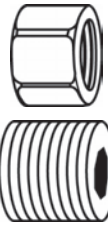

Description	Part number
Male	Male
G 1/8" (5 x 10)	906.333.106
G 1/4" (8 x 13)	906.333.102
G 3/8" (12 x 17)	906.333.104
G 1/2" (15 x 21)	906.333.103
G 3/4" (20 x 27)	906.333.105

## MALE TO MALE FITTINGS (PROTECTIVE COATED STEEL) PMAX: 400 BAR FITTINGS CONFIGURATION



Male/Male	1/2" JIC	3/4" JIC	7/8" JIC
1/2" JIC	050.102.301	905.160.201	550.914
3/4" JIC	905.160.201	905.160.202 - - 550.545	550.915
7/8" JIC	550.914	550.915	-

## MALE TO FEMALE FITTINGS (STAINLESS STEEL) PMAX: 360 BAR FITTINGS CONFIGURATION



Male/Female	1/2" JIC
3/4" JIC	050.123.301



**MALE TO MALE ADAPTERS: PMAX: 360 BAR  
PROTECTED STEEL FITTINGS CONFIGURATION**



Male/Male	1/2" JIC	3/4" JIC
1/4" NPT	000.972.025	905.160.212
3/8" NPT	000.972.028	905.160.206
1/2" NPT	-	905.160.204
3/4" NPT	-	905.160.203

**STAINLESS STEEL FITTINGS CONFIGURATION**

Male/Male	1/2" JIC	3/4" JIC
1/8" NPT	905.210.501	-
1/4" NPT	905.210.502	905.210.512
3/8" NPT	905.210.503	905.210.513
1/2" NPT	905.210.504	905.210.514
3/4" NPT	-	905.210.515

**PROTECTED STEEL FITTING CONFIGURATION**

Male/Male	1/2" JIC	3/4" JIC	7/16" JIC	7/8" JIC	1 1/16" JIC	1 5/16" JIC
1/8" G co	550.548	-	550.920	-	-	-
1/4" G co	550.542	-	-	-	-	-
3/8" G co	550.549	550.679	-	550.609	-	-
1/2" G co	-	550.544	-	550.540	550.903	-
3/4" G co	550.905	-	-	550.823	550.864	550.932
1" G co	-	-	-	-	550.900	550.901

**NICKEL-COATED FITTINGS CONFIGURATION**

Male/Male	1/2" JIC	3/4" JIC
3/8" NPT	050.470.202	905.160.103

**MALE TO FEMALE ELBOW FITTINGS  
PMAX: 360 BAR  
FITTINGS CONFIGURATION**



Male/Female (free nut)	1/2" JIC
1/2" JIC	905.160.101

**MALE TO MALE ELBOW FITTINGS (STAINLESS STEEL)  
PMAX: 360 BAR  
FITTINGS CONFIGURATION**



Male/Male	1/2" JIC	3/4" JIC
1/4" NPT	905.210.602	905.210.612
3/8" NPT	905.210.603	-
1/2" NPT	905.210.604	-
3/4" NPT	-	905.210.615

**MALE TO MALE ELBOW FITTINGS (PROTECTIVE COATED STEEL)  
PMAX: 360 BAR  
NPT FITTINGS CONFIGURATION**

Male/Male	1/2" JIC	3/4" JIC
1/8" NPT	905.160.105	-
1/4" NPT	-	905.160.102

**G CO FITTING CONFIGURATION**

Male/Male	1/2" JIC	3/4" JIC
1/4" G co	550.596	550.923
3/8" G co	551.819	-

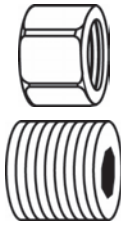

**PLUGS PMAX: 360 BAR**

**PLUGS CONFIGURATION**

Description	Part number
Female 1/2" JIC	906.333.301
Male 1/8" NPT	906.333.108

**LOW PRESSURE VALVES**

**3 WAYS VALVE PART NUMBERS**

Description	Part number
3 x 1/4" BSP (female)	903.090.804
3 x 1/4" BSP (female) (stainless steel)	903.090.805

**2 WAYS MALE/MALE VALVE PART NUMBERS**

Description	Input	Output	Part number
Ball valve	(M) G 1/4" (8 x 13)	(M) M 14 x 125	050.070.205
Inlet (male) G 3/8" (12 x 17) outlet (male) M 14 x 125	(M) G 3/8" (12 x 17)	(M) M 1/4" NPS	050.070.211
Inlet (male) G 1/2" (15 x 21) outlet (male) M 18 x 125	(M) G 1/2" (15 x 21)	(M) M 18 x 125	050.070.204
Inlet (male) G 1/2" (15 x 21) outlet (male) de0101G 1/2 (15 x 21)	(M) G 1/2" (15 x 21)	(M) M 18 x 125	050.070.201
Inlet (male) G 3/8" (12 x 17) outlet (male) M 18 x 125	(M) G 3/8" (12 x 17)	(M) M 18 x 125	050.070.212

**2 WAYS FEMALE/FEMALE VALVE PART NUMBERS**

Description	Input	Output	Part number
Valve	(F) 1/4" BSP (8 x 13)	(F) 1/4" BSP (8 x 13)	903.090.806
Valve	(F) 3/8" BSP (12 x 17)	(F) 3/8" BSP (12 x 17)	903.090.206

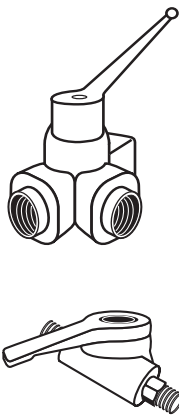

**AIR BLEEDING VALVES**

**AIR BLEEDING VALVE PART NUMBER**

Description	Part number
Inlet thread (male) G 1/4" (8 x 13)	903.093.302

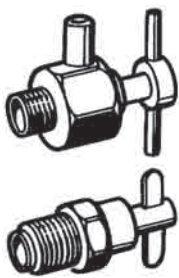

**NEEDLE VALVES**

**2 WAYS VALVE PART NUMBERS**

Description	Input	Output	Part number
Female/Male	M 14 x 125	M 14 x 125	050.070.179
Male/Male	G 1/4" (8 x 13)	M 14 x 125	050.070.101

**3 WAYS VALVE PART NUMBERS**

Description	Part number
Female/male/male M 14 x 125	050.070.401



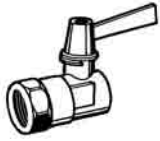

**HIGH PRESSURE FLUID VALVES**

**PART NUMBER**

Description	Input	Output	Maximum fluid pressure (bar)	Part number
Female/Female	G 3/8" (12 x 17)	G 3/8" (12 x 17)	250 bar	000.750.040

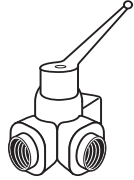

**3 WAYS VALVE - 350 BAR - PART NUMBERS**

Description	Part number
3 x 1/4" BSP (female) (stainless steel)	903.091.006

**AIR LINE OUTPUT CONTROL VALVES**

**VALVE PART NUMBERS**



Description	Input	Output	Part number
Female/Male	G 1/4" (8 x 13)	G 1/8" (8 x 13)	050.070.190
Female/Male	M 14 x 125	M 14 x 125	050.070.179

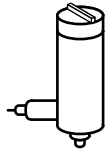

**BLEEDING VALVES**

**BLEEDING VALVES PART NUMBERS**

Description	Input	Output	Maximum fluid pressure (bar)	Part number
Male/Male	G 1/4" (8 x 13)	M 18 x 125	400	000.760.000

**FITTINGS - GENERAL INFORMATION**

**DETAILS**

Denomination	Fitting characteristics	Geographical area	Max. operating pressure (bar)
M	cylindrical metric	France	20
G = BSP	conical gas (or cylindrical)	Europe - Asia	60
NPT	conical	USA - Asia	60
NPS	cylindrical	USA - Asia	60
JIC	cylindrical angle 74°	Universal	360



## REGULATORS

1/4" (with grey or red knob) , 1/2" and 3/4" (with red ring) regulators are used on the compressed air lines.

### CHARACTERISTICS

Regulator	1/4"	1/2"	3/4"
Max. inlet pressure (bar)	9	20	21
Max. output (m <sup>3</sup> /h)	25	210	360

### CONFIGURATION

Description	Pressure (bar)	Type	Part number
Red knob regulator	3,5	1/4"	016.240.000
Grey knob regulator	3,5	1/4"	016.380.000
2 regulators 1/4" with isolating valves 2 manometers, 1 inlet valve - 1 outlet valve M 1/4" NPS	3,5 & 9	1/4"	019.400.000
Grey knob regulator	5,5	1/4"	016.390.000
Red knob regulator	5,5	1/4"	016.370.000
Regulator with pressure gauge inlet fitting 1/4" - outlet fitting M1/4" NPS	5,5	1/4"	019.720.000
Grey knob regulator	9	1/4"	016.360.000
Phosphor knob regulator	9	1/4"	016.365.500
Bare regulator	4	1/2"	016.200.000
Bare regulator	9	1/2"	016.280.000
Equipped regulator with pressure gauge and wall bracket	10	1/2"	019.780.100
2 regulators (1/4" + 1/2") with isolating valves 2 manometers, 1 inlet valve - 2 outlet valves M 1/4" NPS	9	1/4"	019.390.000
Red ring regulator	10	1/2"	016.470.000
Red ring regulator	10	3/4"	016.480.000
Wall bracket	-		016.180.010

## DE 37 PURIFIER-REGULATOR WITH FILTER CARTRIDGES

Usually fitted in the paint spray booths. Its twin-body construction ensures completely water and oil free.

### Technical characteristics:

- Maximum operating air output: 37 m<sup>3</sup>/h
- Maximum operating air pressure: 10 bar
- Height: 290 mm
- Air inlet opening: F1/4"G

### Standard equipment:

- One regulated pressure gauge
- One F1/4"G
- One tap valve F1/4"G
- Two air outlet taps: M 1/4" NPS



### SPECIFICATIONS

Air output (m <sup>3</sup> /h)	37
Maximum fluid pressure (bar)	10
Height (cm)	29
Fitting	Air Inlet F8 x 13G
Set-up	1 regulated pressure gauge 1 valve F 1/4" G 1 ball valve F 1/4" G 2 air outlet taps M 1/4" NPS

### PART NUMBERS

Description	Part number
Purifier with DE 37 regulator	015.240.000
Blue cartridge for water	015.230.500
Red cartridge for oil	015.230.200

**REGULATORS, FILTERS AND LUBRICATORS**

Regulators with pressure gauges, filters and lubricators with polycarbon reservoirs are all modular, allowing you to put together the best air treatment equipment for your needs.



Part 1

- Filter with trunnion deflector, transparent polycarbon reservoirs (heat resistant up to 50°C), manual bleed and a bronze filter capable of holding all particles larger than 5 microns.
- Regulator with pressure gauge: self-regulating and vibration free, pressure gauges from 0 to 12 bar/180 psi, equipped with automatic decompression system
- Lubricator with transparent polycarbon lid (heat resistant up to 50°C), flush adjustment screw; it lubricates by fine vaporisation
- Maximum operating pressure: 12 bar/180 psi

**REGULATORS, FILTERS, LUBRICATORS CONFIGURATION (PART 1)**

Type	Inlet diameter	Outlet diameter	Output at 9 bar (l/mn)	Part number
<b>Regulator with gauge</b>				
M 150/2	1/4"	1/4"	1000	004.601.100
M 250/3	1/2"	1/2"	5250	004.601.300
<b>Filter with polycarbonate tank</b>				
M 100/2	1/4"	1/4"	1760	004.603.100
M 200/2	3/8"	3/8"	7000	004.603.200
<b>Lubricator with polycarbonate tank</b>				
M 110/2	1/4"	1/4"	2500	004.604.100
M 210/3	1/2"	1/2"	5250	004.604.300

**REGULATORS, FILTERS, LUBRICATORS CONFIGURATION (PART 2)**

Type	Inlet diameter	Outlet diameter	Part number
Bare 3/4" regulator	3/4" G	3/4" G	91.530
Bare 3/4" regulator + filter	3/4" G	3/4" G	91.532
3/4" regulator with manometer Ø 62 mm	3/4" G	3/4" G	91.531
3/4" regulator with manometer Ø 62 mm + filter	3/4" G	3/4" G	91.533
Filter 3/4" regulator	3/4" G	3/4" G	91.534
3/4" regulator, filter, lubricator, adjusting valve on wall base	1/2" G	1/2" G	91.398
Bare 1/4" regulator	1/4" G	1/4" G	91.551
Bare 1/4" regulator + filter	1/4" G	1/4" G	91.555
1/4" regulator with manometer Ø 62 mm	1/4" G	1/4" G	91.552
1/4" regulator with manometer Ø 62 mm + filter	1/4" G	1/4" G	91.558
Bare 1/4" filter	1/4" G	1/4" G	91.553
Ø 62 mm manometer side output - 0 to 10 bar	1/8" G	-	151.080.094
Ø 62 mm manometer rear output - 0 to 10 bar	1/8" G	-	151.080.091
Wall bracket for 3/4" regulators	-	-	210.006
Reatining ring for regulator (mounting on control panel)	-	-	91.540
Locking mechanism for regulators	-	-	91.545
Adjusting valve with lock	-	-	91.544
Lubrication oil (2 liters)	-	-	149.990.017



Part 2



## ACCESSORIES

Allow the easy assembly and fitting of regulators, lubricators and filters to provide the ideal system.

### PART NUMBERS

Description	Part number
Regulator support bracket F 171/1 for 1/8" and 1/4"	004.601.002
Regulator support bracket F 176/1 for 3/8" and 1/2"	004.601.201



## PRESSURE GAUGES

Built to last in metal with glass lenses, they are completely impact and solvent resistant.

### CONFIGURATION

Description	Internal diameter (mm)	Pressure range (bar)	Part number
Pressure gauge - central inlet	40	0 - 6	910.011.205
	40	0 - 2,5	910.011.208
Pressure gauge - central inlet	50	0 - 6	910.011.403
	50	0 - 10	910.011.402
Pressure gauge - side inlet	50	0 - 4	910.011.404

## PRACTICAL PAGES

### CHOOSING A PUMP

To optimize

- For the best pump capacity, first work out the output you are going to require. This will include the sprayguns themselves, and any circulation you plan to have within this system. Once you have this figure, multiply by 1.2, and then choose the pump of which output at 30 cycles per minute is the nearest.
- The compression ratio you will need is defined by the pressure losses due to the length and diameter of the hosing of your system. To calculate these pressure losses, see page 109.

#### Example

let say you want to feed 3 conventional guns with an output of 500 cc/mn each, plus a circulation of 0,5 l/mn.

The total output will thus be 2 l/mn. The optimal pump capacity would be:  $(2\ 000 \times 1,2) \div 30 = 80$  cc/cycle.

The best-suited pumps will be:

- » the PMP 150 (output of 100 cc/cycle and pressure ratio of 1:1) for low viscosity materials and a small circulating (pressure loss < 3 bar).
- » the 02.75 (output of 85 cc/cycle and pressure ratio of 2:1) for thicker materials and a normal circulating (pressure loss < 6 bar).
- » the 04.120 (output of 240 cc/cycle and pressure ratio 4:1) for large pressure loss in circulating (up to 15 bar).

### PUMP MATERIAL FEEDING

To guarantee the right delivery of product, we offer the following range of equipment for various product viscosity:

- » 0 - 300 cps
  - suction rod.
- » 300 to 8 000 cps
  - top outlet pressure pots,
  - pumps (gravity or suction rod),
  - pump with base intake valve.
- » 8 000 to 15 000 cps
  - bottom outlet pressure pots,
  - pumps with suction rods,
  - compressor.
- » 15 000 to 30 000 cps
  - no more pressure pot,
  - no more suction rod,
  - submerged hydraulic pump,
  - compressor,
  - pump with single action elevator.
- » 30 000 à 1 000 000 cps and +
  - pumps with peak feeder and double action elevator.

# PRACTICAL PAGES

## FILTRATION EQUIVALENCE

Mesh (number of holes in 25,4 mm)	Micron	N° filtre (mesh opening in µm)
10	1480	–
16	975	–
20	750	30
25	630	25
30	500	20
40	375	–
45	360	15
50	300	12
60	238	–
70	210	8
80	175	6
100	149	–
140	100	4
170	90	3
200	74	–
250	60	–
270	50	2
325	40	1
400	35	–

## PRESSURE LOSS IN FLUID HOSES

Pressure drop is the resistance that prevents material from moving forward in the pipe. Two pipe variables influence this resistance: the (inside/internal) diameter and the pipe length. The pump will generate a pressure, strong enough to move the fluid material through the pipe (or hose) to the material pipe outlet. This pressure must be enough to overcome the original pressure drop. While it is hard to reduce the pipe length, it is relatively easy to select an appropriate internal pipe diameter.

### PRESSURE DROP CALCULATION

$$\text{Pressure loss (bar/m)} = \frac{6.9 \times \text{Flow (l/min)} \times \text{Viscosity (cps)}}{D^4 \text{ (int dia in mm)}}$$

$$\text{Pressure loss (psi/Ft)} = \frac{2.73 \times \text{Flow (gpm)} \times \text{Viscosity (cps)}}{D^4 \text{ (int dia in inches)}}$$

### FLOW RATE CALCULATION

$$\text{Flow (l/min)} = \frac{\text{Pressure loss (bar/m)} \times D^4 \text{ (int dia in mm)}}{6.9 \times \text{Viscosity (cps)}}$$

$$\text{Flow (gpm)} = \frac{\text{Pressure loss (psi/Ft)} \times D^4 \text{ (int dia in inches)}}{2.73 \times \text{Viscosity (cps)}}$$

### PIPE DIAMETER CALCULATION

$$\text{Interior Dia (mm)} = \sqrt[4]{\frac{6.9 \times \text{Flow (l/min)} \times \text{Viscosity (cps)}}{\text{Pressure Loss (bar/m)}}}$$

$$\text{Interior Dia (in)} = \sqrt[4]{\frac{2.73 \times \text{Flow (gpm)} \times \text{Viscosity (cps)}}{\text{Pressure loss (psi/Ft)}}}$$



# PRACTICAL PAGES

## PRESSURE LOSS IN AIR HOSES

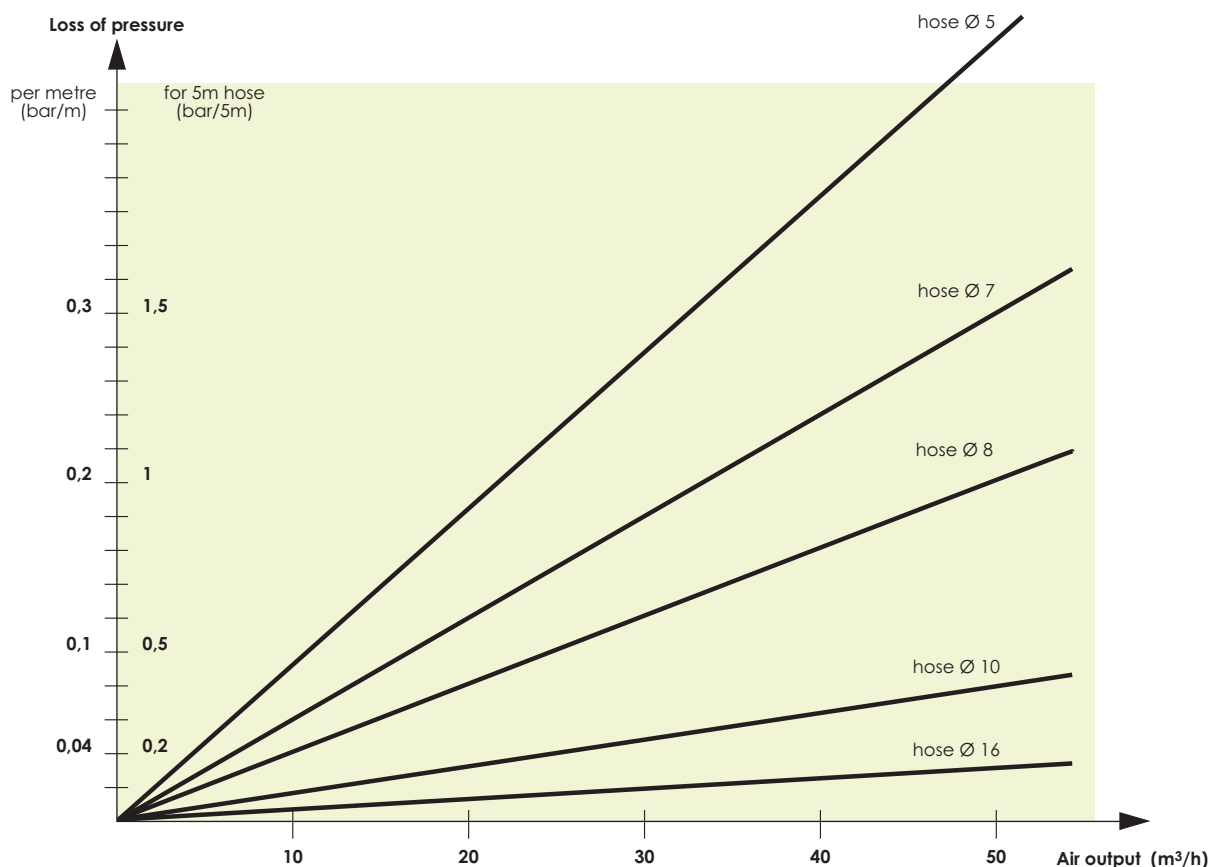

## LIST SHOWING THE COMPRESSED AIR CONSUMPTION OF NORMAL AIR TOOLS

We generally multiply the instant consumption by a coefficient of 0,5 to 0,9 to allow for the time the tool is not in use.

The average air volume delivered by a compressor of 1 CV is of 8 m<sup>3</sup>/h.

Tool	Consumption	
	l/mn	m <sup>3</sup> /h
Projection equipment	800 at 1 800	48 at 108
Riveter	450 at 1 500	27 at 90
Pneumatic drill	600 at 1 200	36 at 72
Linisher Ø 230	1 200 at 4 000	72 at 240
Drill 13 mm	600	36
Rotating sander	200 at 400	12 at 24

Tool	Consumption	
	l/mn	m <sup>3</sup> /h
Conventional gun	160 at 500	10 at 30
AIRMIX® gun	67 at 134	4 at 8
Pumps	160 at 1 350	10 at 80
Blower	200 at 400	12 at 24
Screwdriver	200 at 400	12 at 24

### Calculate exactly the maximum air consumption of pump in l/mn : Q

The formula is :

$$Q = 1.2 \times \text{fluid output} \times \text{pressure ratio} \times (\text{air motor feeding pressure in bar} + 1 \text{ bar for atmosphere})$$

Example for a pump 16.120 :  $Q = 1.2 \times 4,8 \times 16 \times (6 + 1) = 645.12 \text{ l/mn}$  or  $(645.12 \times 60) : 1000 = 38.7 \text{ m}^3/\text{h}$

# PRACTICAL PAGES

## VALUE OF « PH »

The pH value of a liquid or a solution quantifies its concentration of hydrogen ions and tells us the extent to which it is acidic or alkaline. The PH value dictates the best materials to be used in construction of major paint handling and spraying equipment.

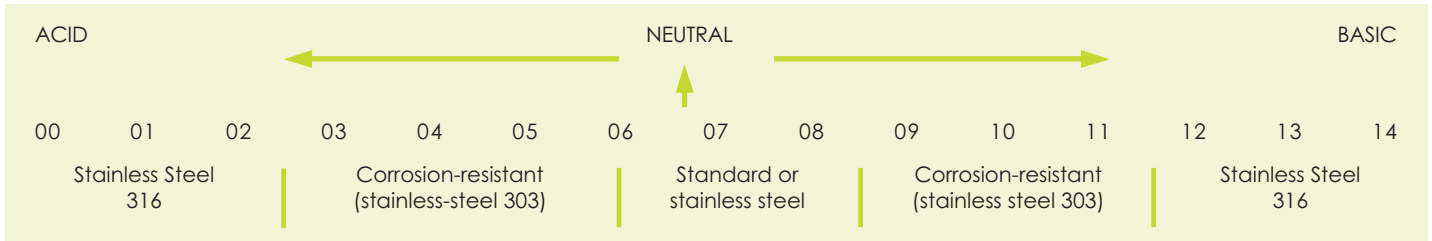

## PRACTICAL INFORMATION: METRIC - ENGLISH CONVERSION

CONVERT FROM	TO	MULTIPLY BY
Centimeters	feet	0.03280
Centimeters	inches	0.3937
Centimeters/min.	feet/min.	1.9684
Centimeters/sec.	feet/sec.	0.03281
Cubic centimeters.	cubic feet	3.5314 x 10 <sup>-5</sup>

CONVERT FROM	TO	MULTIPLY BY
Cubic centimeters	ounces	0.033
Cubic centimeters	liquid gallons	0.0002642
Cubic feet	liquid gallons	7.4805
Cubic feet	cubic inches	1.728
Cubic feet/min.	gallons/min.	7.4805

CONVERT FROM	TO	MULTIPLY BY
Cubic inches	gallons	0.004329
Cubic inches	cubic centimeters	16.387
Cubic inches	cubic feet	0.0005787
Cubic meters	liquid U.S. gallons	264.17
Cubic meters	cubic centimeters	1 x 10 <sup>6</sup>

CONVERT FROM	TO	MULTIPLY BY
Cubic meters	cubic feet	35.31
Cubic meters	cubic inches	61,023.38
Feet	centimeters	30.48006
Feet	meters	0.3048006
Feet of water	atmosphère	0.02949

CONVERT FROM	TO	MULTIPLY BY
Feet of water	psi	0.443
Feet/hour	miles/hour	0.00018933
Feet/min.	meters/min.	0.3048
Feet/min.	miles/hour	0.01136
Feet/sec.	miles/hour	0.681818

CONVERT FROM	TO	MULTIPLY BY
Gallons	cubic cm	3 785.43
Gallons	cubic inches	231
Gallons	imperial gallons	0,83268
Gallons	cubic feet	0,13368
Gallons/min.	cubic feet/min.	0,13368

CONVERT FROM	TO	MULTIPLY BY
Inches	feet	0,083333
Inches	meters	0,254
Inches	millimeters	25,40005
Inches	mils	1 000
Kilograms	pounds	2,2046

CONVERT FROM	TO	MULTIPLY BY
Kilogrammes/cm <sup>2</sup>	psi	14,2233
Kilogrammes/mm <sup>2</sup>	psi	1 422,33
Liters	gallons	0,264178
Meters	feet	3,2808
Meters	inches	39,37

CONVERT FROM	TO	MULTIPLY BY
Poise	centipoise	100,0
Pints of water	gallons	0,11985
PSI	atmosphère (bar)	0,06804
Inches <sup>2</sup>	cm <sup>2</sup>	6,4516
Inches <sup>2</sup>	feet <sup>2</sup>	0,006944
Inches <sup>2</sup>	mm <sup>2</sup>	645,163
Millimètres <sup>2</sup>	inches <sup>2</sup>	0,0015499
daN	Kilograms	1.0

- » For the diameter of a circle, multiply the circumference by 0.31831.
- » For the circumference of a circle, multiply the diameter by 3.1416.
- » For the surface of a circle, multiply the diameter<sup>2</sup> by 0.7854.
- » For the surface of a sphere, multiply the diameter<sup>2</sup> by 3.1416.
- » To find the side of a square that has the same surface area of a circle, multiply the diameter by 0.8862.
- » To find the number of cubic inches in a sphere, multiply the diameter by 0.5236.
- » To find the number of gallons inside a pipe or cylinder, divide the volume in liters by 231.
- » To find the cubic volume of a cylinder or pipe, multiply the section area by the length.

# PRACTICAL INFORMATION

## CHEMICAL COMPATIBILITY CHARTS

### MATERIAL IN CONTACT (WETTED PARTS)

	Carbon steel	Aluminium	Brass	Stainless steel	Nylon	Nitrile	Vitton	Leather	P.U.
Butyl acetate	👍👍👍	👍👍👍	👍👍👍	👍👍👍	👍👍👍	N	N		N
Ethyl acetate	👍👍	👍👍	👍👍	👍👍	👍👍👍	N			
Acetaldehyde	👍👍👍	👍👍👍	👍👍👍	👍👍👍	👍👍👍	N	N	👍👍	N
Amonium acetate				👍👍👍					
Acedic acid	👍👍👍			👍👍👍	👍👍👍	N	N	N	N
Boric acid	👍👍👍	👍👍👍		👍👍👍	👍👍👍		👍👍👍	👍👍👍	👍👍👍
Hydrobromic acid					👍👍👍	N	👍👍👍		
Chloridic acid	N	N		N	👍👍👍	N	👍👍👍		
Chromic acid	N	N	N	👍	👍👍👍	N			
Citric acid				👍👍👍	👍👍👍		👍👍👍		
Fluorohydric acid						N	👍👍👍		
Fluosilicic acid			👍👍👍		👍👍👍	N	N		
Formic acid	N	👍👍	N	👍	👍👍👍	N	👍		
Nitric acid	N	N	N	👍👍👍	👍👍👍	N	👍👍👍		
Oxylic acid	N	N	N	N	👍👍👍		👍👍👍	👍👍👍	👍👍👍
Phosphoric acid	N	N		👍👍👍	👍👍👍	N	👍👍👍		
Ethylalcohol						👍👍👍	N		
Methylalcohol	👍👍👍						N	👍👍👍	N
Acetic aldehyde	👍👍👍	👍👍👍		👍👍👍	👍👍👍	N	N		N
Formic aldehyde	N	👍👍	N	N	👍👍👍	N	👍👍👍		N
Sodium alginate					👍👍👍		N		
Starch						👍👍👍	👍👍👍		
Amines					👍👍👍	N	N	N	
Acetone	👍👍👍	👍👍👍		👍👍	👍👍👍	N	N		N
Liquid ammonia	👍👍👍	👍👍👍		👍👍👍	👍👍	👍👍	N	N	
Benzene	👍👍👍	👍👍👍	👍👍👍	👍👍👍	👍👍👍	N	👍👍👍	👍👍	👍
Sodium bicarbonate		N	N	👍👍👍	👍👍👍	👍👍👍	👍👍👍		
Chlorine dioxide						N	👍👍👍		
Sodium bisulphate	N	N		N	👍👍👍	N	👍👍👍		
Brominate						N			
Calcium carbonate	👍👍👍			👍👍👍	👍👍👍	👍👍👍	👍👍👍	👍👍👍	
Sodium carbonate					👍👍👍		👍👍👍		
Chlorinate, gas						👍👍👍	👍👍👍		
Sodium chlorite							👍👍👍		👍👍👍
Aluminum chlorosulfate					👍👍👍	👍👍👍	👍👍👍	👍👍👍	
Calcium chloride	👍👍👍			👍👍👍	👍👍👍		👍👍👍		👍👍👍
Magnesium chloride	👍👍	N		N	👍👍👍	👍👍👍	👍👍👍	👍👍👍	👍👍👍
Potassium chloride	N	N		👍👍	👍👍👍	👍👍👍	👍👍👍	👍👍👍	👍👍👍
Sodium chloride					👍👍👍	👍👍👍	👍👍👍		👍👍👍
Zinc chloride	N	N		N	👍👍👍	👍👍👍	👍👍👍		👍👍👍
Ferrous chloride	N	N	N	N	👍👍👍		👍👍👍		
Ferric chloride	N	N	N	N	👍👍👍		👍👍👍		👍👍👍
Cyclohexane	👍👍👍	👍👍👍	👍👍👍	👍👍👍	👍👍👍	👍👍👍	👍👍👍		
Chlorobenzene	👍👍👍			👍👍👍	👍	N	👍👍👍		N
Ethylene chloride		👍👍			👍👍	N	👍👍		N
Methylene chloride	👍👍	N	👍👍	👍👍	N	N	👍👍		N
Diatoms						👍👍👍	👍👍👍		
Dichloroethylene					👍👍👍				
Diethylene glycol	👍👍👍	👍👍		👍👍👍	👍👍👍	👍👍👍	👍👍👍		N
Bleach	N	👍👍		👍👍👍	👍👍👍				👍
Distilled water	N	👍👍👍	👍👍👍	👍👍👍	👍👍👍		👍👍👍	👍👍👍	👍👍👍
Oxygenated water	N		N	👍👍	N		👍👍		👍👍👍
EDTA						👍👍👍	N		

# PRACTICAL INFORMATION

## CHEMICAL COMPATIBILITY CHARTS

### MATERIAL IN CONTACT (WETTED PARTS)

	Carbon steel	Aluminium	Brass	Stainless steel	Nylon	Nitrile	Vitton	Leather	P.U.
Fertilizer						☺☺☺	N		
Ethanol					☺☺☺	☺☺☺	N		
Ethyl ether	☺☺	☺☺		☺☺	☺☺☺	N	N		☺
Ethylene glycol	☺☺	☺☺	☺☺☺	☺☺	☺☺☺	☺☺☺	☺☺☺		N
Ethyl-mercapan						N	☺☺☺		
Fuel						N	☺☺☺		
Fluosilicate			☺☺☺		☺☺☺	☺☺☺	☺☺☺		
Formaldehyde	N	☺☺		N	☺☺	☺☺☺	☺☺☺		N
Glycol	☺☺	☺☺		☺☺	☺☺☺	☺☺☺	☺☺☺		N
Gelatine	N	☺☺		☺☺☺	☺☺☺	N	N		N
Sodium hydroxide					☺☺☺	N	N		N
Ammonium hydroxide				☺☺☺	☺☺☺	N	N	☺☺	N
Potassium hydroxide	☺	N		☺☺☺	☺☺☺	N	N		N
Calcium hypochlorite				☺	☺☺☺	N	☺☺☺	N	
Sodium hypochlorite					☺☺☺	N	☺☺☺		N
Sodium hyposulfite					☺☺☺	N	☺☺☺		
Fruit juice						☺☺☺	☺☺☺		
Methanol	N	☺☺☺		☺☺☺			N		☺
Morpholine	☺☺☺	☺☺☺				N	N		
Methylethylcetone	☺☺☺	☺☺		☺☺☺	☺☺☺	N	N		N
Sodium nitrite					N	N	☺☺☺		
Perchloroethylene (tetrachloref.)	☺☺☺	☺☺		☺☺☺	N	☺☺	☺☺☺		N
Permanganate de potassium	☺☺	☺☺		☺☺	☺☺☺	N	☺☺☺		
Hydrogen peroxide	N	☺☺☺	N	☺☺		N	☺☺		
Chlorohated Peroxyde						N	☺☺☺		
Phenol	N	N			☺☺☺	N	☺☺☺		
Ammonium phosphate			☺☺☺	☺☺☺	☺☺☺	☺☺☺	☺☺☺		
Trisodium phosphate	☺☺☺	N		☺☺☺	☺☺☺	☺☺☺	☺☺☺		
Aluminium polychlorite						☺☺☺	☺☺☺		
Polyelectrolytes						☺☺☺	☺☺☺		
Caustic potash		N		☺☺☺		N	☺☺☺		
Sodium silicate					☺☺☺	☺☺☺	☺☺☺		
Soda						N	N		
Aluminium sulfate					☺☺☺	☺☺☺	☺☺☺	☺☺☺	N
Ammonium sulfate					☺☺☺				☺☺☺
Calcium sulfate	☺☺☺	☺☺☺		☺☺☺	☺☺☺		☺☺☺		
Copper sulfate				☺☺☺	☺☺☺	☺☺☺	☺☺☺		☺☺☺
Ferrous sulfate		N		☺☺	☺☺☺	☺☺☺	☺☺☺		
Ferric sulfate	N	N		N	☺☺☺	☺☺☺	☺☺☺		☺☺☺
Sodium sulfate	N				☺☺☺	☺☺☺	☺☺☺		
Hydrogen sulfur	☺☺☺				☺☺☺	☺☺☺	N		
Carbon tetrachloride	☺☺		☺☺☺	☺☺☺	☺☺☺	N	☺☺☺		
Toluene	☺☺☺	☺☺☺		☺☺☺	N	N	☺☺☺		N
Trichlorethane	☺☺	N		☺☺	N	N	☺☺☺		N
Trichlorethylene	☺☺	☺☺☺		☺☺	N	N			N
Triethyleneglycol				☺☺	☺☺☺		☺☺☺		
Urea	☺☺	☺☺		☺☺	☺☺☺		☺☺☺		
Xylenes	☺☺	☺☺		☺☺	☺☺☺	N	☺☺☺		N

☺☺☺ = High Compatibility      ☺ = Low Compatibility  
 ☺☺ = Good Compatibility      N = Not Compatible



# Bond | Protect | Beautify

With our manual guns, automatic and robotic applicators, supplied by our wide range of pumps & machines for fluid handling, dosing, mixing & dispensing.

**SAMES KREMLIN** provides industrial solutions for production increase, quality improvement, material & cost savings.

We are designers and manufacturers of process equipment that is divided into 6 ranges:

**Airspray:** Since 1925, we have been an Airspray manufacturer bringing you the very best in finishing.

**Airmix®:** Creator of Airmix® Technology since 1975, we provide the perfect mix between quality and productivity.

**Airless:** We provide premium Airless Products for finishers with demanding applications.

**REXSON Dispense:** Pumping beyond possible, dispensing precisely.

**Electrostatic:** Expertise for high finishing quality & efficiency.

**Powder:** Powder coating solutions for the highest Productivity since 1960.

FIND YOUR  
LOCAL CONTACT  
BY FLASHCODE:



[www.sames-kremlin.com](http://www.sames-kremlin.com)



13 chemin de Malacher - CS 70086  
38243 MEYLAN Cedex - FRANCE  
Phone: +33 (0)4 76 41 60 60 - Fax: +33 (0)4 76 41 60 90