

Bond | Protect | Beautify

With our manual guns, automatic and robotic applicators, supplied by our wide range of pumps & machines for fluid handling, dosing, mixing & dispensing.

SAMES KREMLIN provides industrial solutions for production increase, quality improvement, material & cost savings.

We are designers and manufacturers of process equipment divided in 6 ranges:

Airspray: manufacturer since 1925, bringing you the very best of the Finishing.

Airmix®: creator since 1975, bringing the perfect mix between quality and productivity.

Airless: premium for Finishers in heavy applications

Rexson High Viscosity: pumping beyond possible, dispensing precisely.

Electrostatic: expertise for high finishing quality since 1954.

Powder: coating solutions for highest Productivity since 1960

FIND YOUR
LOCAL CONTACT
BY FLASHCODE:



www.sames-kremlin.com



Apply your Skills



AIRMIX® 17F60 & AIRLESS 34F60 FLOWMAX® PAINT PUMP

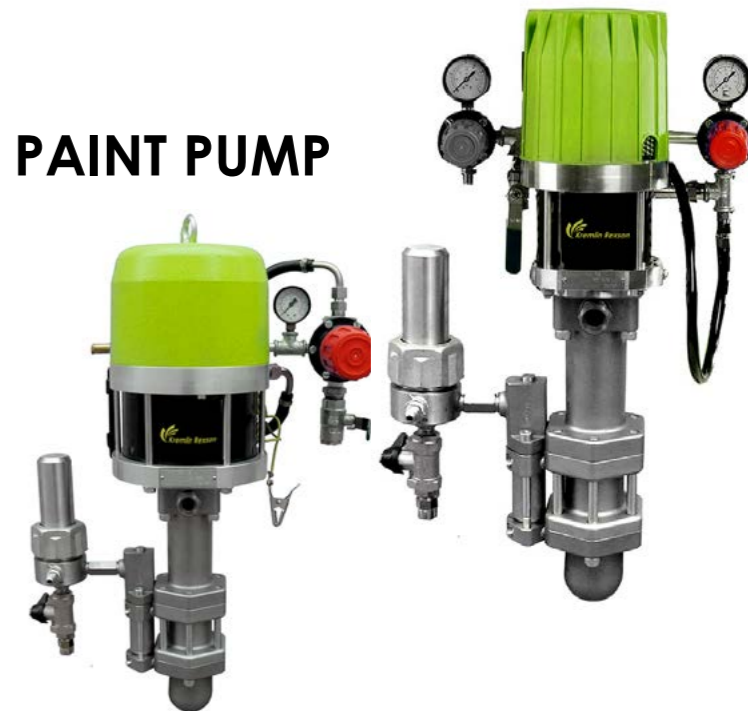

Unique bellow technology

15 years of experience

Extended lifetime

Related Technologies



FLOWMAX®
feeding



GT Sealing



2 Ball



Triple
chrome
layer

Apply your Skills

www.sames-kremlin.com

AIRMIX® 17F60 & AIRLESS 34F60 FLOWMAX®



TECHNICAL DATA

	AIRMIX® 17F60 Flowmax®	AIRLESS 34F60 Flowmax®
Pressure ratio	17/1	34/1
Output per cycle (cc)		60
Maximum material pressure (bar)	100	200
Material flow at 30 cycles/min (L/min)		1.8
Max working temperature (°C)		60
Working pressure air in (bar)		2 to 6
Material outlet		3/8"
Valve air inlet	3/8" BSP	3/4" BSP
Fluid inlet siphon hose fitting		26 x125

FLOWMAX® TECHNOLOGY

Recognized as a major innovation in fluid handling since 1925, the AIRMIX® 17F60 and AIRLESS 34F60 FLOWMAX® pumps bring the possibility to pump the widest range of materials on the market including moisture sensitive or waterbone based materials.

With its unsurpassed quality bellows, the AIRMIX® 17F60 and AIRLESS 34F60 FLOWMAX® pumps ensure total sealing, performance, an extended lifetime and reliability.

The unique design with external valves allows very easy maintenance.

Creator of the FLOWMAX® bellow technology 15 years ago, SAMES KREMLIN has always proved its ability to stay innovative.

MATERIAL HANDLED

Water-based and solvent-based materials, varnishes, stains, 2K materials and moisture sensitive.

RECOMMENDED MARKETS



CONSTRUCTION EQUIPMENT

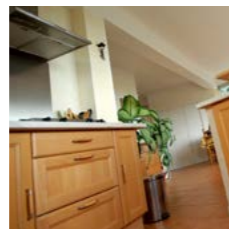

KITCHEN AND BATHROOM

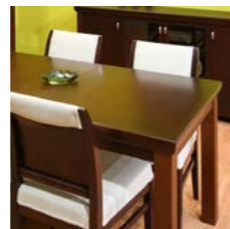

FURNITURE



ROLLING EQUIPMENT

CUSTOMER BENEFITS

- Increased lifetime ←
- No lubrication ←
- High reliability ←
- Superlife™ bellow seal ←

STAINLESS STEEL WETTED PART

Compatible with widest range of material (paints, varnishes and liquid adhesives)

VERY QUIET AIR MOTOR

With the ultimate ceramic reversing block increasing air motor lifetime

BELLOW PROVEN

- Leak free technology
- No lubricating cup
- Maintenance free
- Ideal for catalyst and moisture sensitive material.

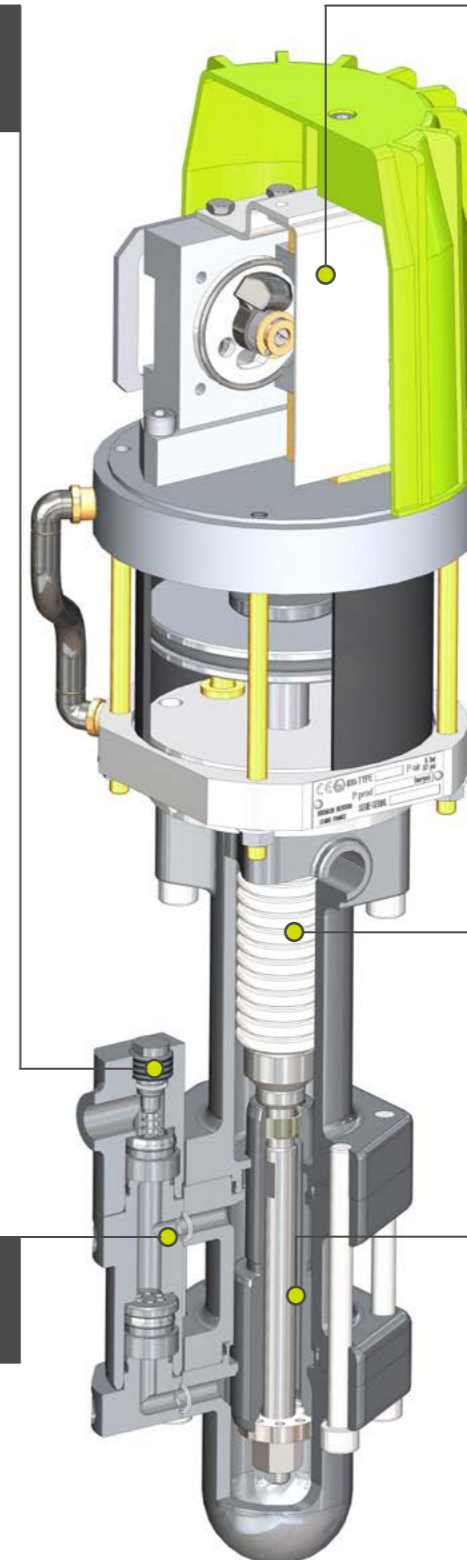

EXTERNAL VALVE ASSEMBLY

- Easy maintenance
- Easy access for a fast servicing

FLOATING PISTON

- Reducing material shear and increasing seal lifetime
- Balance output on both stroke ideal for automatic application



www.sames-kremlin.com