

**EXPERTS IN FINISHING
AND DISPENSING SOLUTIONS
FOR ALL MARKETS WORLDWIDE**

**AIRLESS
ASI 24
& ASI 40**



WHERE TO FIND US ?

WWW.KREMLIN-REXSON.COM

► ABOUT US

└ GLOBAL PRESENCE



KREMLIN REXSON, creator of **AIRMIX®**, **FLOWMAX®** and **CYCLOMIX™** technologies, offer a wide range of pumps and equipment for the protection of materials and application of paints, sealants and adhesives.



150, avenue de Stalingrad - 93245 STAINS cedex - FRANCE
Phone : +33 1 49 40 25 25 - Fax.: +33 1 48 26 07 16

1203.573.677.002 - KREMLIN REXSON reserves right to change without notice characteristics and services offered as well as equipment and attachments of these.

AUTOMATIC AIRLESS SPRAYGUNS

- Full stainless steel fluid passage
- 50 years of experience
- High cycling rate (opening/closing)

Experts in Finishing and Dispensing Solutions



www.kremlin-rexson.com

AIRLESS ASI 24 & ASI 40



TECHNICAL DATA

	AIRLESS ASI 24	AIRLESS ASI 40
Maximum fluid operating pressure (bar)	240	400
Minimum air driven pressure (bar)	3	3.5
Fluid flowrate (l/mn)	Up to 4.5 depending on material viscosity	
Weight (g)	700	
Maximum operating temperature (°C)	100	
Seat construction	Carbide / stainless steel (ASI 40 GT)	
Wetted parts	Carbide, stainless steel, treated stainless steel, PTFE or GT seal	

AIRLESS TECHNOLOGY

Developed for high production rate, ASI guns provide fine atomization at medium to high flow delivery.

They are providing excellent finish quality with limited overspray and are recommended to apply harsh coatings, high viscosity and abrasive materials...

AIRLESS atomization allows to make installations with long distance between pumps and spray guns without additional atomizing air hose.

MATERIAL HANDLED

Medium to high viscosity primers, anti-corrosion paints, structural paints, U.V paints, released agents, underbody coatings, oil and glues.

RECOMMENDED MARKETS



CONSTRUCTION EQUIPMENT



KITCHEN AND BATHROOM



RENEWABLE ENERGIES



ROLLING EQUIPMENT

CUSTOMER BENEFITS

- Simple construction with limited number of parts ←
- Durability ↓
- Reduced cost of ownership ↓
- Compact and lightweight ←
- Easy servicing and cleaning ←

CIRCULATION IN THE GUN

- To apply viscous or semi-viscous material with limited pressure loss
- Heated fluid installation to prevent product settlement

FULL STAINLESS STEEL PASSAGE

Compatible with a large range of products including waterborne, high solids and U.V paints

RULON OR GT SEAL CARTRIDGE

Strong resistance to very abrasive coating (high solids and U.V paints) for extended lifetime

BALL SEAT CONSTRUCTION

Nickel carbide ball with carbide seat for higher durability

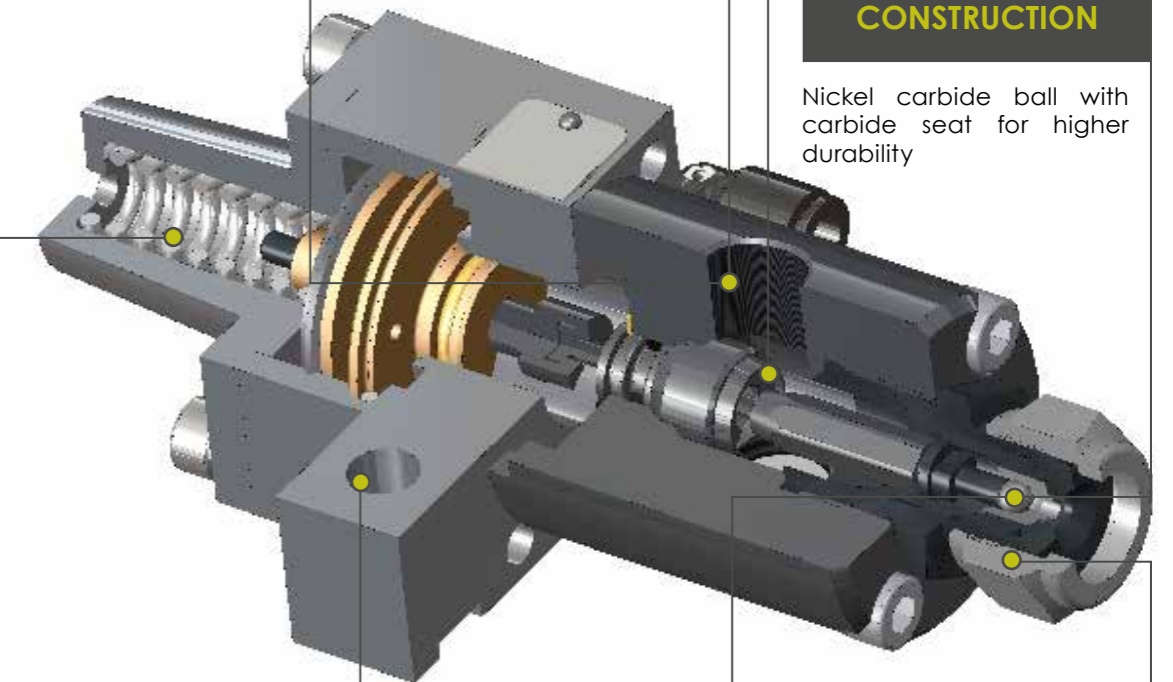

PRESSURE RANGE

- Spring for 240 bar operating pressure (ASI 24)
- Spring for 400 bar operating pressure (ASI 40)

NEEDLE BALL

Two different needle ball sizes for optimal performance and minimal laminar wear upon material viscosity

NO TIPS SEAL NEEDED

Spray tip mounted directly on diaphragm without seal

GUN MOUNTING

Simple mounting on 8 mm round bar. Easy adjustment

